



US011654056B2

(12) **United States Patent**  
**Locke et al.**

(10) **Patent No.:** **US 11,654,056 B2**  
(45) **Date of Patent:** **May 23, 2023**

(54) **MEDICAL SYSTEM AND DRESSING FOR USE UNDER COMPRESSION**

(71) Applicant: **KCI Licensing, Inc.**, San Antonio, TX (US)

(72) Inventors: **Christopher Brian Locke**, Bournemouth (GB); **Justin Alexander Long**, Lago Vista, TX (US); **Benjamin Locke**, Bournemouth (GB); **Benjamin Andrew Pratt**, Poole (GB); **Thomas Alan Edwards**, Hampshire (GB); **Timothy Mark Robinson**, Shillingstone (GB)

(73) Assignee: **KCI Licensing, Inc.**, San Antonio, TX (US)

(\*) Notice: Subject to any disclaimer, the term of this patent is extended or adjusted under 35 U.S.C. 154(b) by 694 days.

(21) Appl. No.: **16/717,754**

(22) Filed: **Dec. 17, 2019**

(65) **Prior Publication Data**  
US 2020/0121512 A1 Apr. 23, 2020

**Related U.S. Application Data**

(62) Division of application No. 15/356,063, filed on Nov. 18, 2016, now Pat. No. 10,548,777.  
(Continued)

(51) **Int. Cl.**  
*A61F 13/02* (2006.01)  
*A61F 13/00* (2006.01)  
*A61M 1/00* (2006.01)

(52) **U.S. Cl.**  
CPC .. *A61F 13/00068* (2013.01); *A61F 13/00029* (2013.01); *A61F 13/025* (2013.01);  
(Continued)

(58) **Field of Classification Search**  
CPC ..... *A61F 13/00068*; *A61F 13/0216*; *A61F 13/00029*; *A61F 13/0206*; *A61F 13/022*; *A61F 13/025*  
See application file for complete search history.

(56) **References Cited**

U.S. PATENT DOCUMENTS

1,355,846 A 10/1920 Rannells  
2,547,758 A 4/1951 Keeling  
(Continued)

FOREIGN PATENT DOCUMENTS

AU 550575 B2 3/1986  
AU 745271 B2 3/2002  
(Continued)

OTHER PUBLICATIONS

U.S. Non-Final Office Action Corresponding to U.S. Appl. No. 16/755,814, dated Jan. 31, 2022.  
(Continued)

*Primary Examiner* — Susan S Su

(57) **ABSTRACT**

In some illustrative examples, a bridge suitable for treating a tissue site may include a bridge sealing member and one or more bridge wicking layers. The bridge sealing member may extend along a length of the bridge, and may define an internal passageway in fluid communication between a receiving end of the bridge and a transmitting end of the bridge. The one or more bridge wicking layers may be disposed within the internal passageway of the bridge sealing member. Other apparatus, systems, and methods are disclosed.

**18 Claims, 16 Drawing Sheets**

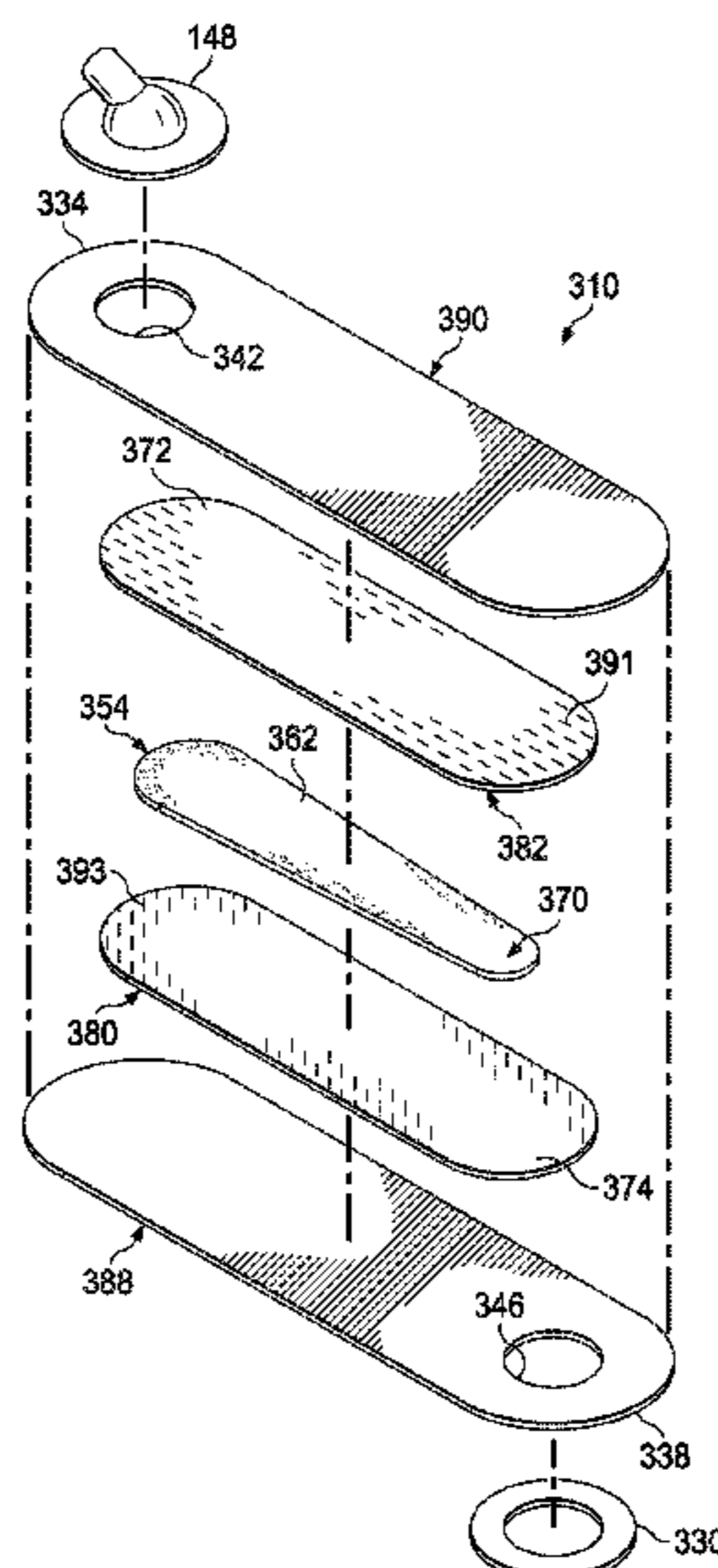

<b>Related U.S. Application Data</b>					
(60)	Provisional application No. 62/257,903, filed on Nov. 20, 2015.	4,969,880 A	11/1990	Zamierowski	
		4,985,019 A	1/1991	Michelson	
		5,037,397 A	8/1991	Kalt et al.	
		5,086,170 A	2/1992	Luheshi et al.	
		5,092,858 A	3/1992	Benson et al.	
		5,100,396 A	3/1992	Zamierowski	
(52)	<b>U.S. Cl.</b>	5,134,994 A	8/1992	Say	
	CPC ..... <i>A61F 13/0216</i> (2013.01); <i>A61F 13/0253</i>	5,149,331 A	9/1992	Ferdman et al.	
	(2013.01); <i>A61M 1/80</i> (2021.05); <i>A61M 1/913</i>	5,167,613 A	12/1992	Karami et al.	
	(2021.05); <i>A61M 1/915</i> (2021.05); <i>A61M</i>	5,176,663 A	1/1993	Svedman et al.	
	<i>1/985</i> (2021.05); <i>A61F 2013/00246</i> (2013.01);	5,215,522 A	6/1993	Page et al.	
	<i>A61M 1/96</i> (2021.05)	5,232,453 A	8/1993	Plass et al.	
		5,261,893 A	11/1993	Zamierowski	
		5,278,100 A	1/1994	Doan et al.	
		5,279,550 A	1/1994	Habib et al.	
		5,298,015 A	3/1994	Komatsuzaki et al.	
		5,342,376 A	8/1994	Ruff	
		5,344,415 A	9/1994	DeBusk et al.	
		5,358,494 A	10/1994	Svedman	
		5,437,622 A	8/1995	Carion	
		5,437,651 A	8/1995	Todd et al.	
		5,527,293 A	6/1996	Zamierowski	
		5,549,584 A	8/1996	Gross	
		5,556,375 A	9/1996	Ewall	
		5,607,388 A	3/1997	Ewall	
		5,636,643 A	6/1997	Argenta et al.	
		5,645,081 A	7/1997	Argenta et al.	
		6,071,267 A	6/2000	Zamierowski	
		6,135,116 A	10/2000	Vogel et al.	
		6,241,747 B1	6/2001	Ruff	
		6,287,316 B1	9/2001	Agarwal et al.	
		6,345,623 B1	2/2002	Heaton et al.	
		6,488,643 B1	12/2002	Tumey et al.	
		6,493,568 B1	12/2002	Bell et al.	
		6,553,998 B2	4/2003	Heaton et al.	
		6,814,079 B2	11/2004	Heaton et al.	
		7,846,141 B2	12/2010	Weston	
		8,062,273 B2	11/2011	Weston	
		8,216,198 B2	7/2012	Heagle et al.	
		8,251,979 B2	8/2012	Malhi	
		8,257,327 B2	9/2012	Blott et al.	
		8,398,614 B2	3/2013	Blott et al.	
		8,449,509 B2	5/2013	Weston	
		8,529,548 B2	9/2013	Blott et al.	
		8,535,296 B2	9/2013	Blott et al.	
		8,551,060 B2	10/2013	Schuessler et al.	
		8,568,386 B2	10/2013	Malhi	
		8,679,081 B2	3/2014	Heagle et al.	
		8,834,451 B2	9/2014	Blott et al.	
		8,926,592 B2	1/2015	Blott et al.	
		9,017,302 B2	4/2015	Vitaris et al.	
		D746,435 S	12/2015	Armstrong et al.	
		9,198,801 B2	12/2015	Weston	
		9,211,365 B2	12/2015	Weston	
		9,289,542 B2	3/2016	Blott et al.	
		2002/0077661 A1	6/2002	Saadat	
		2002/0115951 A1	8/2002	Norstrem et al.	
		2002/0120185 A1	8/2002	Johnson	
		2002/0143286 A1	10/2002	Tumey	
		2005/0101940 A1	5/2005	Radl et al.	
		2006/0079852 A1	4/2006	Bubb et al.	
		2007/0185463 A1	8/2007	Mulligan	
		2008/0195017 A1	8/2008	Robinson et al.	
		2008/0271804 A1	11/2008	Biggie et al.	
		2008/0275409 A1	11/2008	Kane et al.	
		2009/0221977 A1	9/2009	Blott et al.	
		2009/0227969 A1	9/2009	Jaeb et al.	
		2010/0137775 A1	6/2010	Hu et al.	
		2010/0160853 A1	6/2010	Smith et al.	
		2010/0185163 A1*	7/2010	Heagle ..... A61F 13/00068	
				604/290	
		2010/0324510 A1	12/2010	Andresen et al.	
		2010/0324516 A1	12/2010	Braga et al.	
		2011/0230849 A1	9/2011	Coulthard et al.	
		2012/0116334 A1	5/2012	Albert et al.	
		2012/0215193 A1	8/2012	Siniaguine et al.	
		2013/0066284 A1	3/2013	Croizat et al.	
		2013/0096518 A1	4/2013	Hall et al.	
		2013/0123722 A1	5/2013	Pratt et al.	
(56)	<b>References Cited</b>				
	<b>U.S. PATENT DOCUMENTS</b>				
	2,632,443 A	3/1953	Leshner		
	2,682,873 A	7/1954	Evans et al.		
	2,910,763 A	11/1959	Lauterbach		
	2,969,057 A	1/1961	Simmons		
	3,066,672 A	12/1962	Crosby, Jr. et al.		
	3,367,332 A	2/1968	Groves		
	3,520,300 A	7/1970	Flower, Jr.		
	3,568,675 A	3/1971	Harvey		
	3,648,692 A	3/1972	Wheeler		
	3,682,180 A	8/1972	McFarlane		
	3,826,254 A	7/1974	Mellor		
	4,080,970 A	3/1978	Miller		
	4,096,853 A	6/1978	Weigand		
	4,139,004 A	2/1979	Gonzalez, Jr.		
	4,165,748 A	8/1979	Johnson		
	4,184,510 A	1/1980	Murry et al.		
	4,233,969 A	11/1980	Lock et al.		
	4,245,630 A	1/1981	Lloyd et al.		
	4,256,109 A	3/1981	Nichols		
	4,261,363 A	4/1981	Russo		
	4,275,721 A	6/1981	Olson		
	4,284,079 A	8/1981	Adair		
	4,297,995 A	11/1981	Golub		
	4,333,468 A	6/1982	Geist		
	4,373,519 A	2/1983	Errede et al.		
	4,382,441 A	5/1983	Svedman		
	4,392,853 A	7/1983	Muto		
	4,392,858 A	7/1983	George et al.		
	4,419,097 A	12/1983	Rowland		
	4,465,485 A	8/1984	Kashmer et al.		
	4,475,909 A	10/1984	Eisenberg		
	4,480,638 A	11/1984	Schmid		
	4,525,166 A	6/1985	Leclerc		
	4,525,374 A	6/1985	Vaillancourt		
	4,540,412 A	9/1985	Van Overloop		
	4,543,100 A	9/1985	Brodsky		
	4,548,202 A	10/1985	Duncan		
	4,551,139 A	11/1985	Plaas et al.		
	4,569,348 A	2/1986	Hasslinger		
	4,605,399 A	8/1986	Weston et al.		
	4,608,041 A	8/1986	Nielsen		
	4,640,688 A	2/1987	Hauser		
	4,655,754 A	4/1987	Richmond et al.		
	4,664,662 A	5/1987	Webster		
	4,710,165 A	12/1987	McNeil et al.		
	4,733,659 A	3/1988	Edenbaum et al.		
	4,743,232 A	5/1988	Kruger		
	4,758,220 A	7/1988	Sundblom et al.		
	4,787,888 A	11/1988	Fox		
	4,826,494 A	5/1989	Richmond et al.		
	4,838,883 A	6/1989	Matsuura		
	4,840,187 A	6/1989	Brazier		
	4,863,449 A	9/1989	Therriault et al.		
	4,872,450 A	10/1989	Austad		
	4,878,901 A	11/1989	Sachse		
	4,897,081 A	1/1990	Poirier et al.		
	4,906,233 A	3/1990	Moriuchi et al.		
	4,906,240 A	3/1990	Reed et al.		
	4,919,654 A	4/1990	Kalt		
	4,941,882 A	7/1990	Ward et al.		
	4,953,565 A	9/1990	Tachibana et al.		

(56)

References Cited

U.S. PATENT DOCUMENTS

2013/0144230	A1	6/2013	Wu et al.
2013/0310809	A1	11/2013	Armstrong et al.
2014/0163491	A1	6/2014	Schuessler et al.
2014/0276490	A1	9/2014	Locke et al.
2014/0330224	A1	11/2014	Albert et al.
2014/0350494	A1	11/2014	Hartwell et al.
2015/0080788	A1	3/2015	Blott et al.
2015/0141941	A1	5/2015	Allen et al.
2015/0216733	A1	8/2015	Allen et al.
2015/0245950	A1	9/2015	Locke et al.
2016/0106892	A1	4/2016	Hartwell
2016/0120706	A1	5/2016	Collinson et al.
2016/0262942	A1	9/2016	Riesinger
2016/0287765	A1	10/2016	Canner et al.
2016/0339158	A1	11/2016	Collinson et al.
2017/0189236	A1	7/2017	Locke et al.
2018/0325741	A1	11/2018	Lewis et al.
2019/0015258	A1	1/2019	Gowans et al.
2019/0192350	A1	6/2019	Gowans et al.
2019/0343687	A1	11/2019	Locke et al.
2020/0121510	A1	4/2020	Hartwell et al.
2021/0401628	A1	12/2021	Gowans et al.

FOREIGN PATENT DOCUMENTS

AU	755496	B2	12/2002	
CA	2005436	A1	6/1990	
DE	26 40 413	A1	3/1978	
DE	43 06 478	A1	9/1994	
DE	29 504 378	U1	9/1995	
EP	0100148	A1	2/1984	
EP	0117632	A2	9/1984	
EP	0161865	A2	11/1985	
EP	0358302	A2	3/1990	
EP	1018967	A1	7/2000	
EP	3195885	A1	7/2017	
GB	692578	A	6/1953	
GB	2195255	A	4/1988	
GB	2 197 789	A	6/1988	
GB	2 220 357	A	1/1990	
GB	2 235 877	A	3/1991	
GB	2 329 127	A	3/1999	
GB	2 333 965	A	8/1999	
JP	4129536	B2	8/2008	
SG	71559		4/2002	
WO	80/02182	A1	10/1980	
WO	87/04626	A1	8/1987	
WO	90/010424	A1	9/1990	
WO	93/009727	A1	5/1993	
WO	94/20041	A1	9/1994	
WO	96/05873	A1	2/1996	
WO	97/18007	A1	5/1997	
WO	99/13793	A1	3/1999	
WO	0185248	A1	11/2001	
WO	2005051461	A1	6/2005	
WO	2009002260	A1	12/2008	
WO	2009089016	A1	7/2009	
WO	2009126102	A1	10/2009	
WO	2011087871	A2	7/2011	
WO	2013/032539	A1	3/2013	
WO	2014184674	A2	11/2014	
WO	WO-2015050749	A1 *	4/2015	..... A61F 13/0259
WO	2016126444	A1	8/2016	
WO	2017087163	A1	5/2017	
WO	2017196888	A1	11/2017	

OTHER PUBLICATIONS

U.S. Non-Final Office Action Corresponding to U.S. Appl. No. 16/755,814, dated Sep. 1, 2021.  
 International Search Report and Written Opinion for Corresponding Application No. PCT/US2018/055131, dated Mar. 18, 2019.  
 U.S. Non-Final Office Action Corresponding to U.S. Appl. No. 17/046,023, dated Jul. 12, 2022.

International Search Report and Written Opinion for Corresponding Application No. PCT/US2018/048527, dated Dec. 19, 2018.  
 Japanese Notice of Rejection Corresponding to Application No. 2019-513393, dated Aug. 3, 2021.  
 Louis C. Argenta, MD and Michael J. Morykwas, PHD; Vacuum-Assisted Closure: A New Method for Wound Control and Treatment: Clinical Experience; *Annals of Plastic Surgery*; vol. 38, No. 6, Jun. 1997; pp. 563-576.  
 Susan Mendez-Eatmen, RN; "When wounds Won't Heal" *RN* Jan. 1998, vol. 61 (1); Medical Economics Company, Inc., Montvale, NJ, USA; pp. 20-24.  
 James H. Blackburn II, MD et al.: Negative-Pressure Dressings as a Bolster for Skin Grafts; *Annals of Plastic Surgery*, vol. 40, No. 5, May 1998, pp. 453-457; Lippincott Williams & Wilkins, Inc., Philadelphia, PA, USA.  
 John Masters; "Reliable, Inexpensive and Simple Suction Dressings"; Letter to the Editor, *British Journal of Plastic Surgery*, 1998, vol. 51 (3), p. 267; Elsevier Science/The British Association of Plastic Surgeons, UK.  
 S.E. Greer, et al. "The Use of Subatmospheric Pressure Dressing Therapy to Close Lymphocutaneous Fistulas of the Groin" *British Journal of Plastic Surgery* (2000), 53, pp. 484-487.  
 George V. Letsou, MD., et al; "Stimulation of Adenylate Cyclase Activity in Cultured Endothelial Cells Subjected to Cyclic Stretch"; *Journal of Cardiovascular Surgery*, 31, 1990, pp. 634-639.  
 Orringer, Jay, et al; "Management of Wounds in Patients with Complex Enterocutaneous Fistulas"; *Surgery, Gynecology & Obstetrics*, Jul. 1987, vol. 165, pp. 79-80.  
 International Search Report for PCT International Application PCT/GB95/01983; dated Nov. 23, 1995.  
 PCT International Search Report for PCT International Application PCT/GB98/02713; dated Jan. 8, 1999.  
 PCT Written Opinion; PCT International Application PCT/GB98/02713; dated Jun. 8, 1999.  
 PCT International Examination and Search Report, PCT International Application PCT/GB96/02802; dated Jan. 15, 1998 & dated Apr. 29, 1997.  
 PCT Written Opinion, PCT International Application PCT/GB96/02802; dated Sep. 3, 1997.  
 Dattilo, Philip P., Jr., et al; "Medical Textiles: Application of an Absorbable Barbed Bi-directional Surgical Suture"; *Journal of Textile and Apparel, Technology and Management*, vol. 2, Issue 2, Spring 2002, pp. 1-5.  
 Kostyuchenok, B.M., et al; "Vacuum Treatment in the Surgical Management of Purulent Wounds"; *Vestnik Khirurgi*, Sep. 1986, pp. 18-21 and 6 page English translation thereof.  
 Davydov, Yu. A., et al; "Vacuum Therapy in the Treatment of Purulent Lactation Mastitis"; *Vestnik Khirurgi*, May 14, 1986, pp. 66-70, and 9 page English translation thereof.  
 Yusupov, Yu.N., et al; "Active Wound Drainage", *Vestnki Khirurgi*, vol. 138, Issue 4, 1987, and 7 page English translation thereof.  
 Davydov, Yu.A., et al; "Bacteriological and Cytological Assessment of Vacuum Therapy for Purulent Wounds"; *Vestnik Khirurgi*, Oct. 1988, pp. 48-52, and 8 page English translation thereof.  
 Davydov, Yu.A., et al; "Concepts for the Clinical-Biological Management of the Wound Process in the Treatment of Purulent Wounds by Means of Vacuum Therapy"; *Vestnik Khirurgi*, Jul. 7, 1980, pp. 132-136, and 8 page English translation thereof.  
 Chariker, Mark E., M.D., et al; "Effective Management of incisional and cutaneous fistulae with closed suction wound drainage"; *Contemporary Surgery*, vol. 34, Jun. 1989, pp. 59-63.  
 Egnell Minor, *Instruction Book*, First Edition, 300 7502, Feb. 1975, pp. 24.  
 Egnell Minor: *Addition to the Users Manual Concerning Overflow Protection—Concerns all Egnell Pumps*, Feb. 3, 1983, pp. 2.  
 Svedman, P.: "Irrigation Treatment of Leg Ulcers", *The Lancet*, Sep. 3, 1983, pp. 532-534.  
 Chinn, Steven D. et al.: "Closed Wound Suction Drainage", *The Journal of Foot Surgery*, vol. 24, No. 1, 1985, pp. 76-81.  
 Arnljots, Björn et al.: "Irrigation Treatment in Split-Thickness Skin Grafting of Intractable Leg Ulcers", *Scand J. Plast Reconstr. Surg.*, No. 19, 1985, pp. 211-213.

(56)

**References Cited**

## OTHER PUBLICATIONS

Svedman, P.: "A Dressing Allowing Continuous Treatment of a Biosurface", IRCS Medical Science: Biomedical Technology, Clinical Medicine, Surgery and Transplantation, vol. 7, 1979, p. 221.

Svedman, P. et al: "A Dressing System Providing Fluid Supply and Suction Drainage Used for Continuous or Intermittent Irrigation", *Annals of Plastic Surgery*, vol. 17, No. 2, Aug. 1986, pp. 125-133.

N.A. Bagautdinov, "Variant of External Vacuum Aspiration in the Treatment of Purulent Diseases of Soft Tissues," *Current Problems in Modern Clinical Surgery: Interdepartmental Collection*, edited by V. Ye Volkov et al. (Chuvashia State University, Cheboksary, U.S.S.R. 1986); pp. 94-96 (certified translation).

K.F. Jeter, T.E. Tintle, and M. Chariker, "Managing Draining Wounds and Fistulae: New and Established Methods," *Chronic Wound Care*, edited by D. Krasner (Health Management Publications, Inc., King of Prussia, PA 1990), pp. 240-246.

G. Živadinovi?, V. ?uki?, Ž. Maksimovi?, ?. Radak, and P. Peška, "Vacuum Therapy in the Treatment of Peripheral Blood Vessels," *Timok Medical Journal* 11 (1986), pp. 161-164 (certified translation).

F.E. Johnson, "An Improved Technique for Skin Graft Placement Using a Suction Drain," *Surgery, Gynecology, and Obstetrics* 159 (1984), pp. 584-585.

A.A. Safronov, Dissertation Abstract, Vacuum Therapy of Tropic Ulcers of the Lower Leg with Simultaneous Autoplasty of the Skin (Central Scientific Research Institute of Traumatology and Orthopedics, Moscow, U.S.S.R. 1967) (certified translation).

M. Schein, R. Saadia, J.R. Jamieson, and G.A.G. Decker, "The 'Sandwich Technique' in the Management of the Open Abdomen," *British Journal of Surgery* 73 (1986), pp. 369-370.

D.E. Tribble, An Improved Sump Drain-Irrigation Device of Simple Construction, *Archives of Surgery* 105 (1972) pp. 511-513.

M.J. Morykwas, L.C. Argenta, E.I. Shelton-Brown, and W. McGuirt, "Vacuum-Assisted Closure: A New Method for Wound Control and Treatment: Animal Studies and Basic Foundation," *Annals of Plastic Surgery* 38 (1997), pp. 553-562 (Morykwas I).

C.E. Tennants, "The Use of Hypermia in the Postoperative Treatment of Lesions of the Extremities and Thorax," *Journal of the American Medical Association* 64 (1915), pp. 1548-1549.

Selections from W. Meyer and V. Schmieden, *Bier's Hyperemic Treatment in Surgery, Medicine, and the Specialties: A Manual of Its Practical Application*, (W.B. Saunders Co., Philadelphia, PA 1909), pp. 17-25, 44-64, 90-96, 167-170, and 210-211.

V.A. Solovev et al., Guidelines, *The Method of Treatment of Immature External Fistulas in the Upper Gastrointestinal Tract*, editor-in-chief Prov. V.I. Parahonyak (S.M. Kirov Gorky State Medical Institute, Gorky, U.S.S.R. 1987) ("Solovev Guidelines").

V.A. Kuznetsov & N.a. Bagautdinov, "Vacuum and Vacuum-Sorption Treatment of Open Septic Wounds," in *II All-Union Conference on Wounds and Wound Infections: Presentation Abstracts*, edited by B.M. Kostyuchenok et al. (Moscow, U.S.S.R. Oct. 28-29, 1986) pp. 91-92 ("Bagautdinov II").

V.A. Solovev, Dissertation Abstract, *Treatment and Prevention of Suture Failures after Gastric Resection* (S.M. Kirov Gorky State Medical Institute, Gorky, U.S.S.R. 1988) ("Solovev Abstract").

V.A.C.® Therapy Clinical Guidelines: A Reference Source for Clinicians; Jul. 2007.

International Search Report and Written Opinion for PCT/US2016/059905, dated Jan. 26, 2017.

International Search Report and Written opinion for PCT/US2017/062035, dated Feb. 7, 2018.

International Search Report and Written Opinion for Corresponding Application No. PCT/US2019/020308, dated May 10, 2019.

Visco A, Quattrocchi A, Nocita D, Montanini R, Pistone A. Polyurethane Foams Loaded with Carbon Nanofibers for Oil Spill Recovery: Mechanical Properties under Fatigue Conditions and Selective Absorption in Oil/Water Mixtures. *Nanomaterials* (Basel). p. 2.(Year: 2021).

U.S. Final Office Action Corresponding to U.S. Appl. No. 17/046,023 dated Jan. 10, 2023.

U.S. Non-Final Office Action Corresponding to U.S. Appl. No. 16/717,609, dated Jan. 20, 2023.

\* cited by examiner

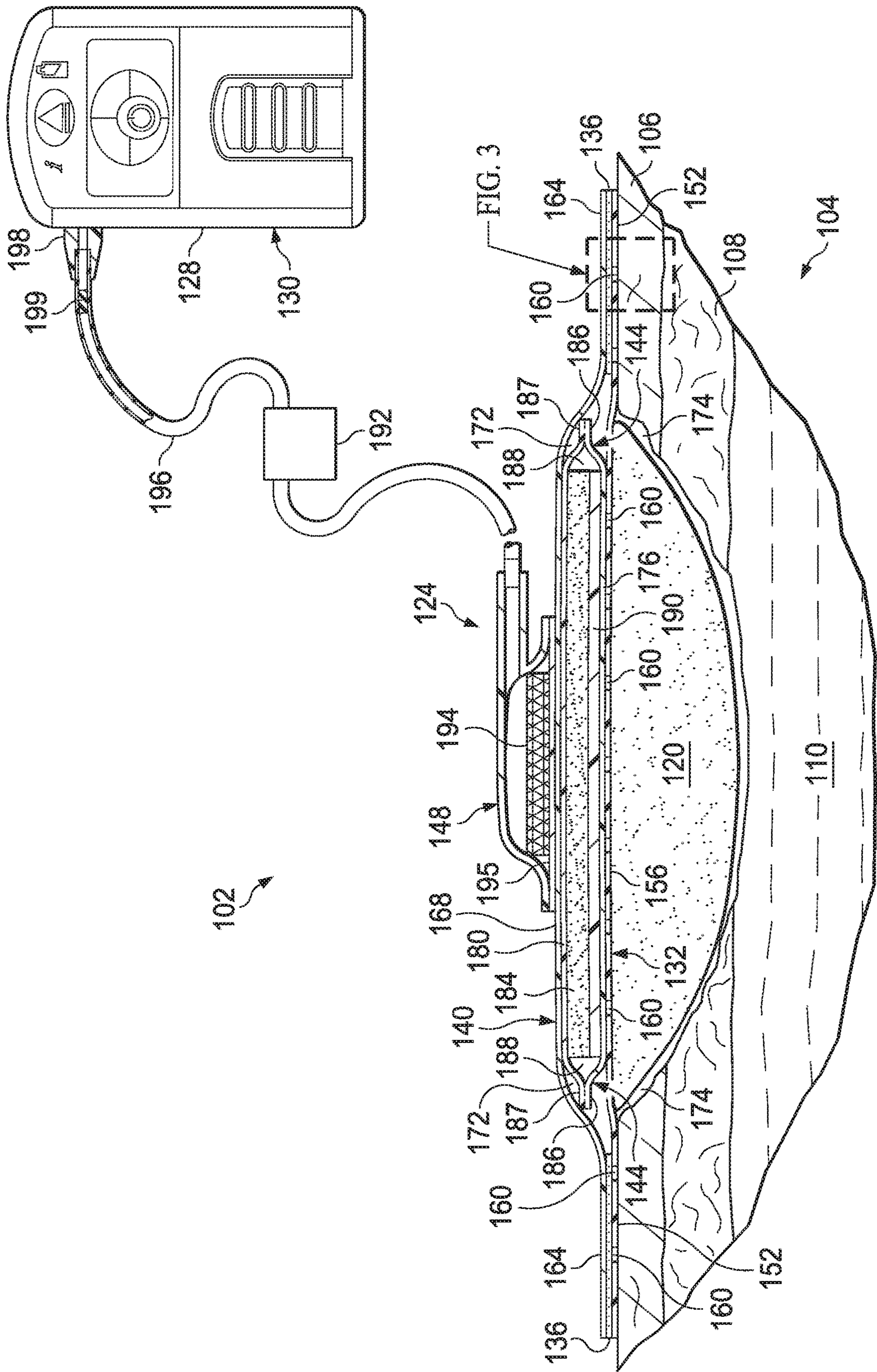

FIG. 1

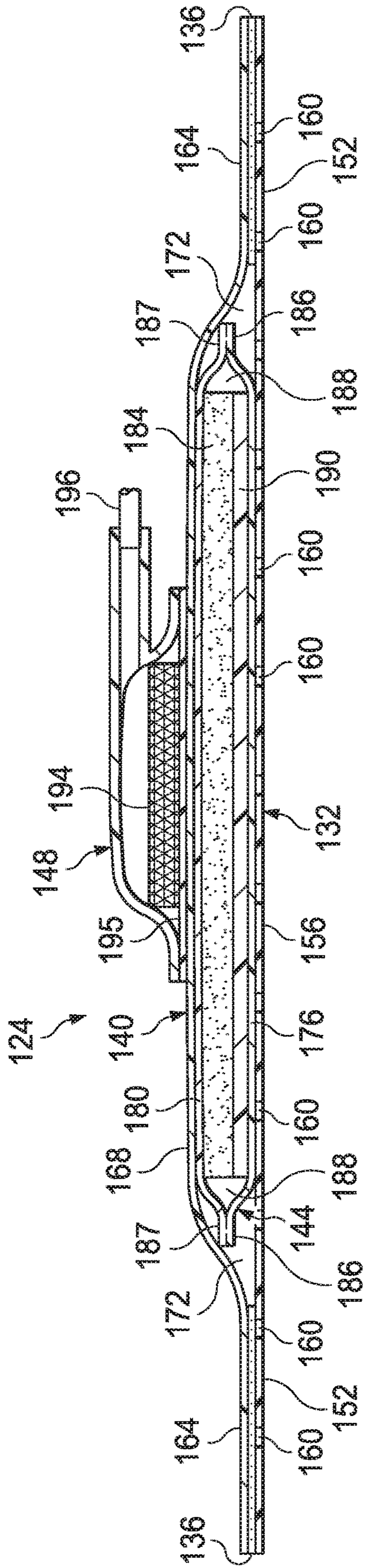

FIG. 2

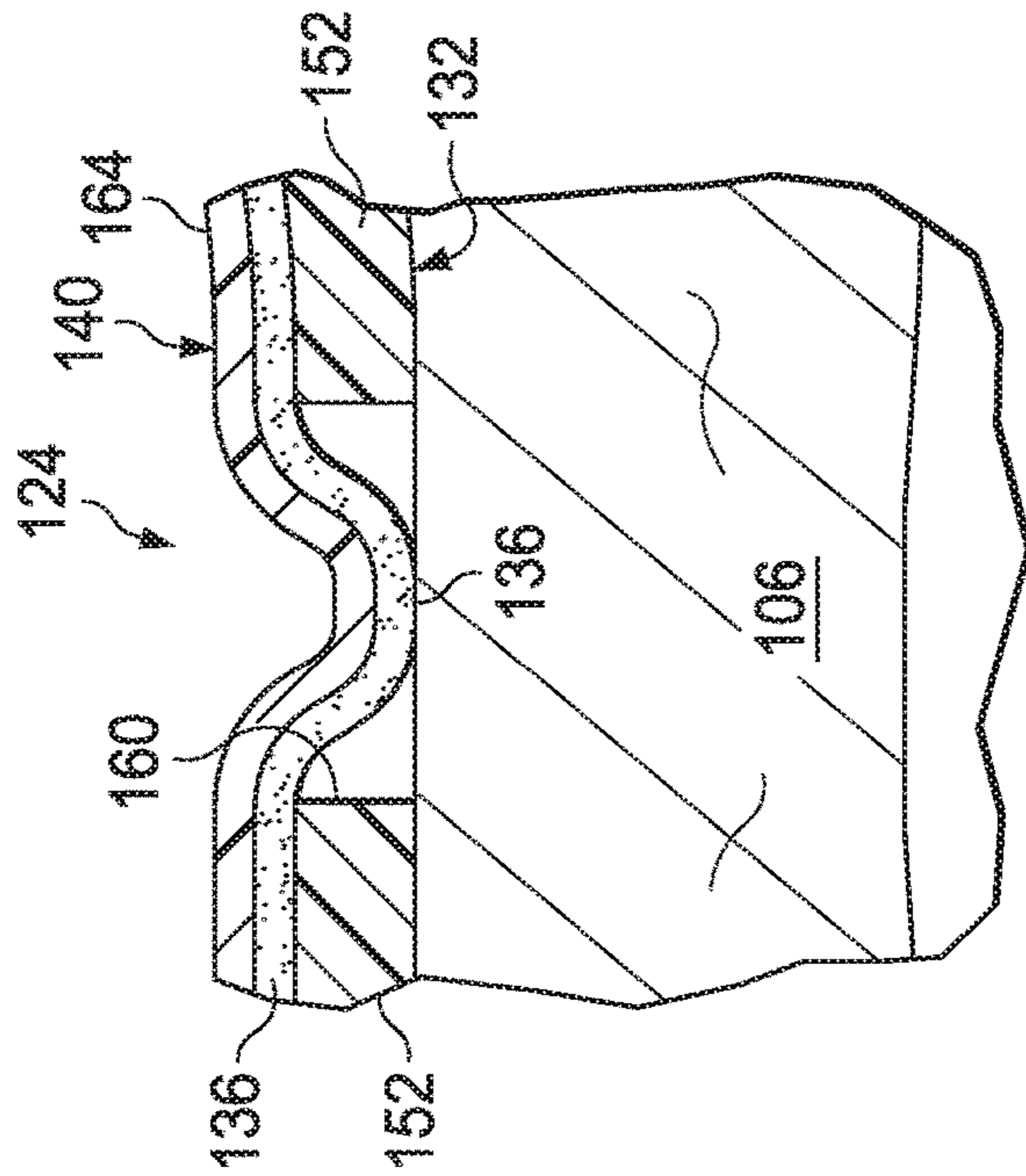

FIG. 3

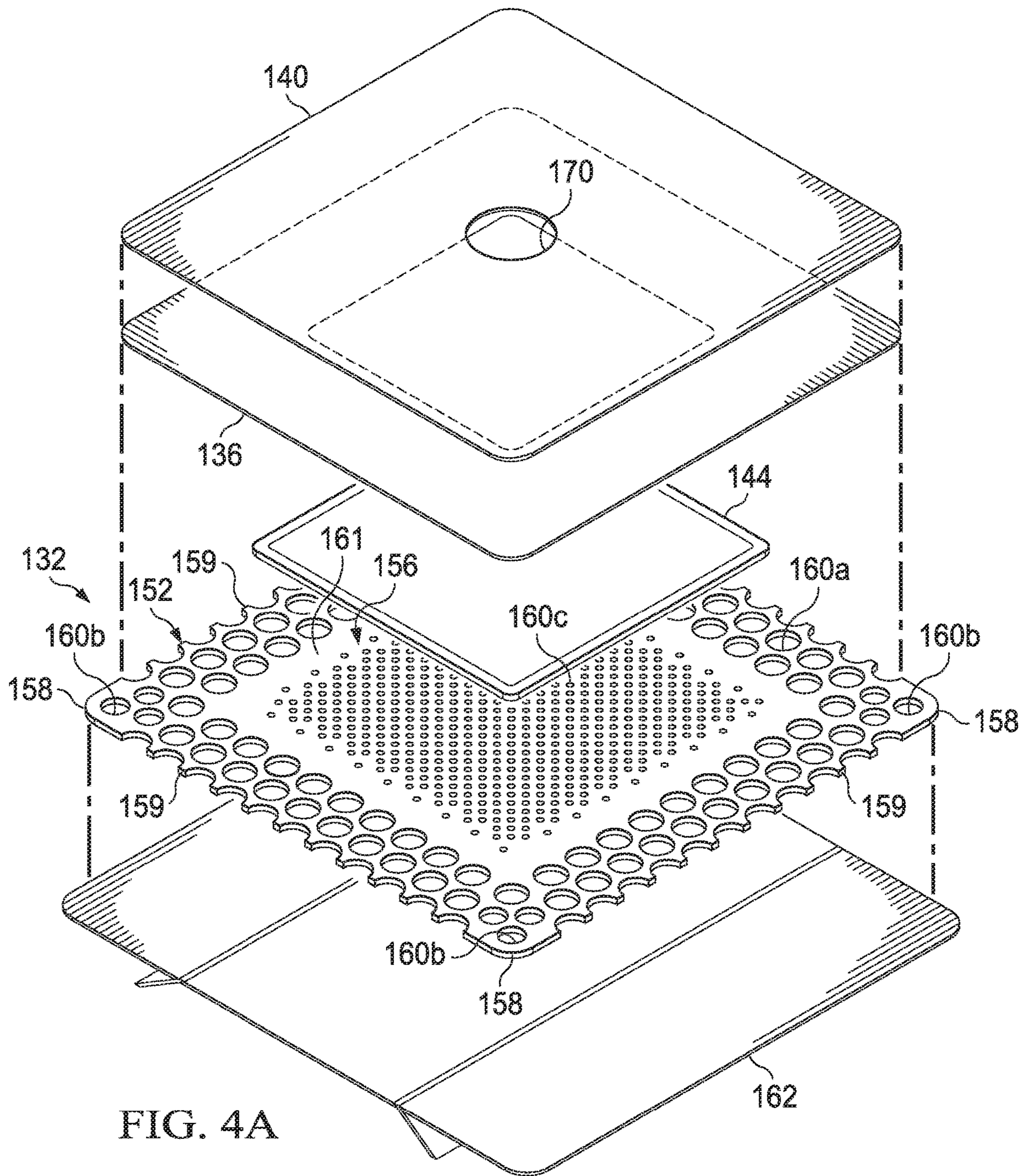

FIG. 4A

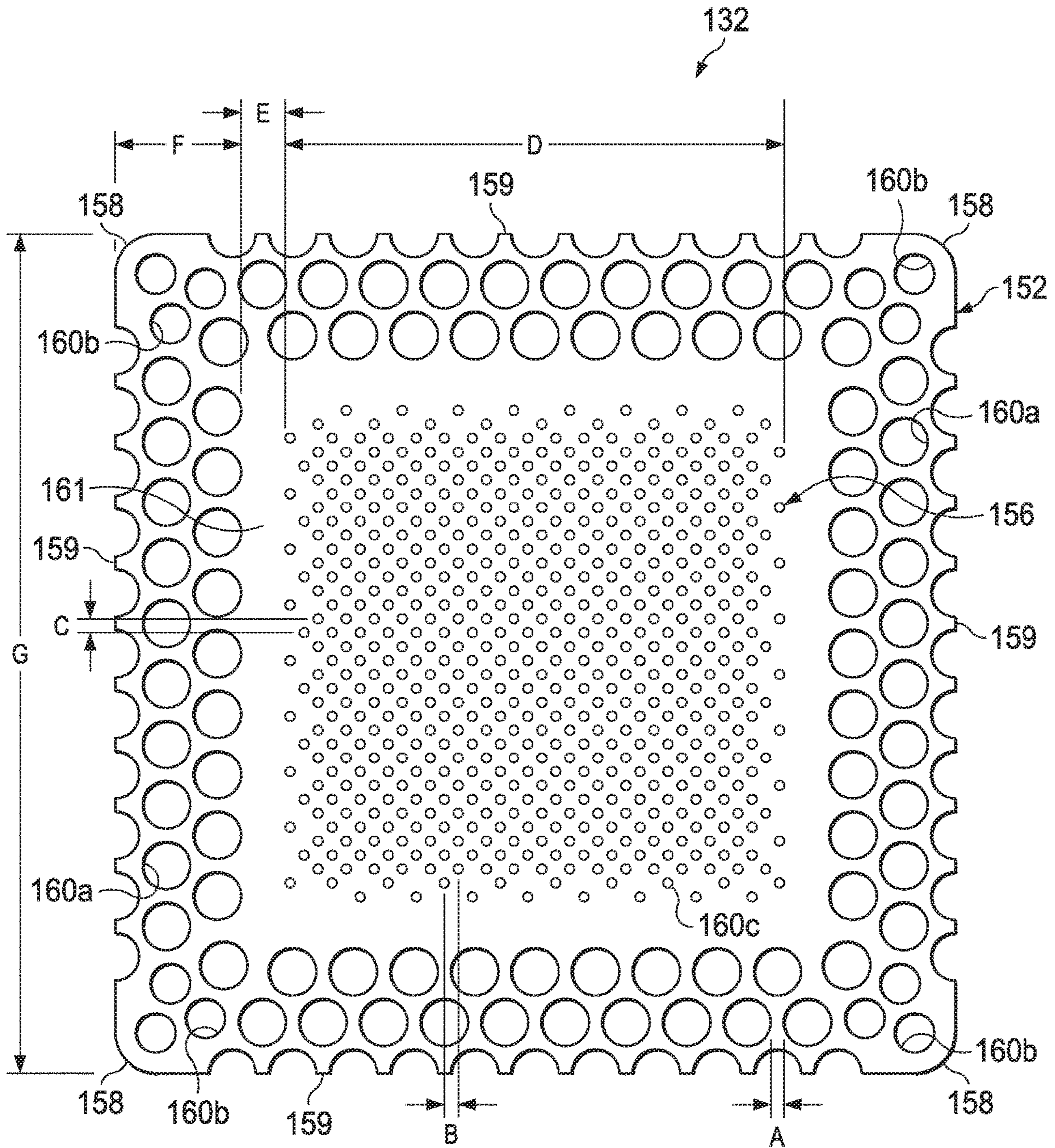

FIG. 4B



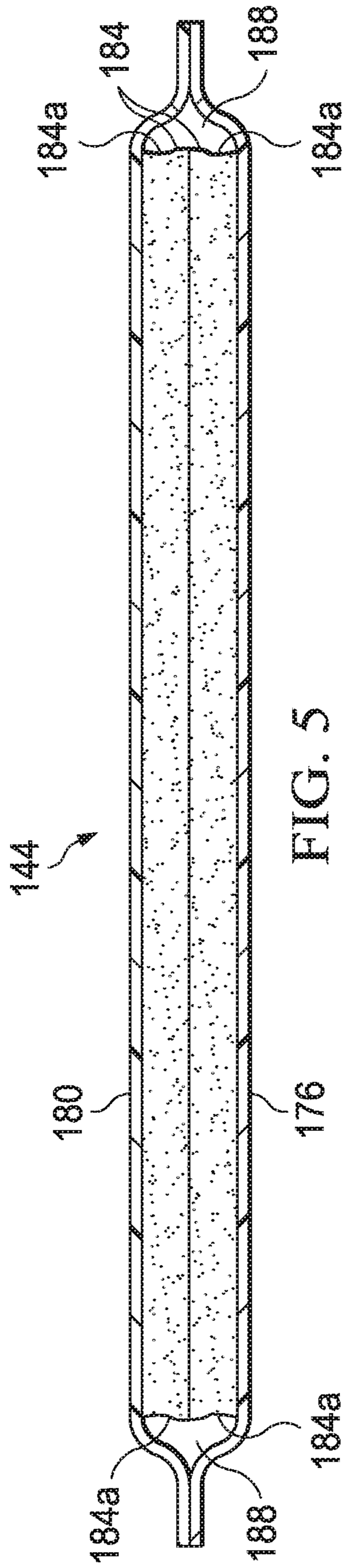

FIG. 5

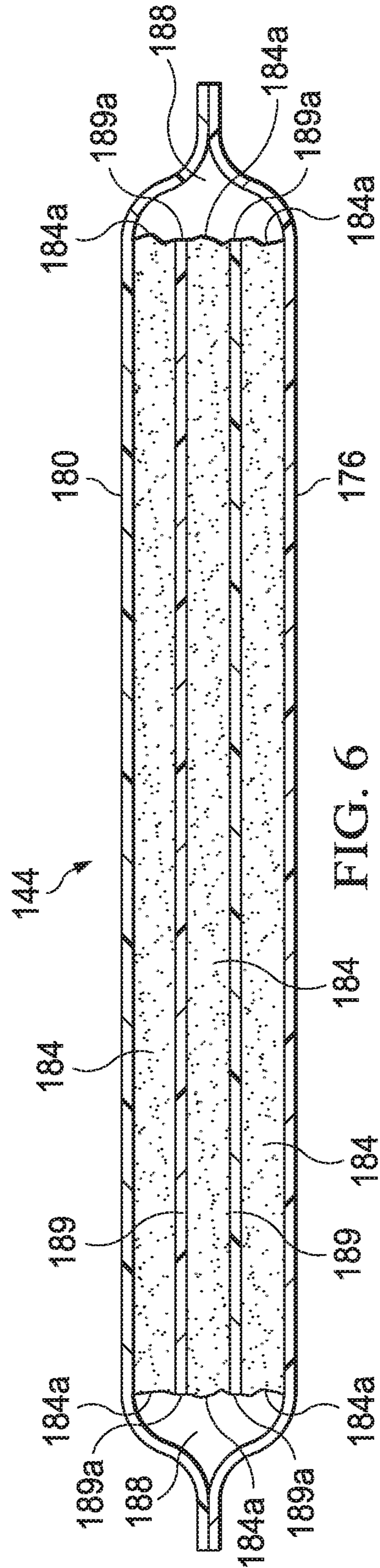

FIG. 6

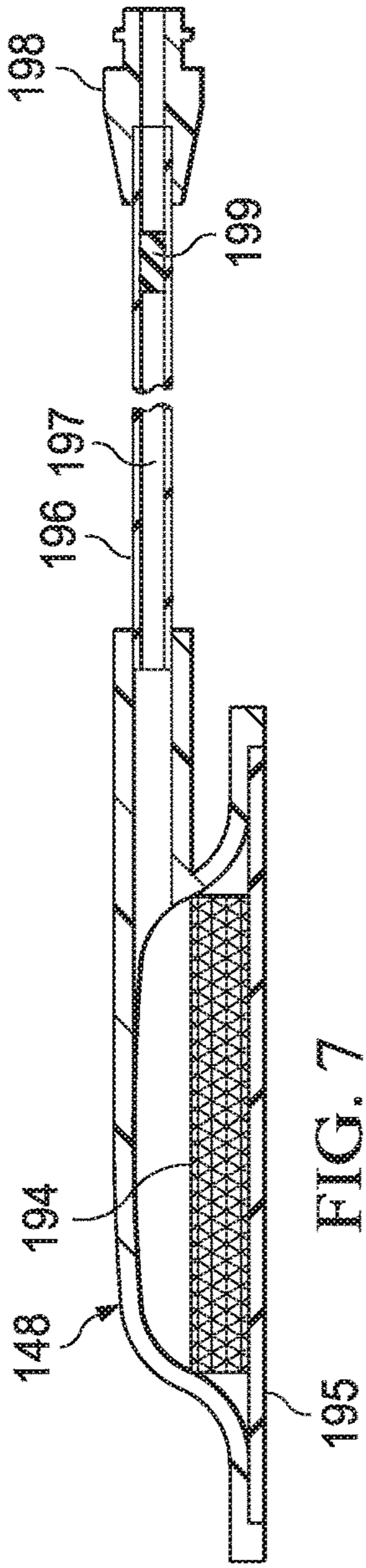

FIG. 7

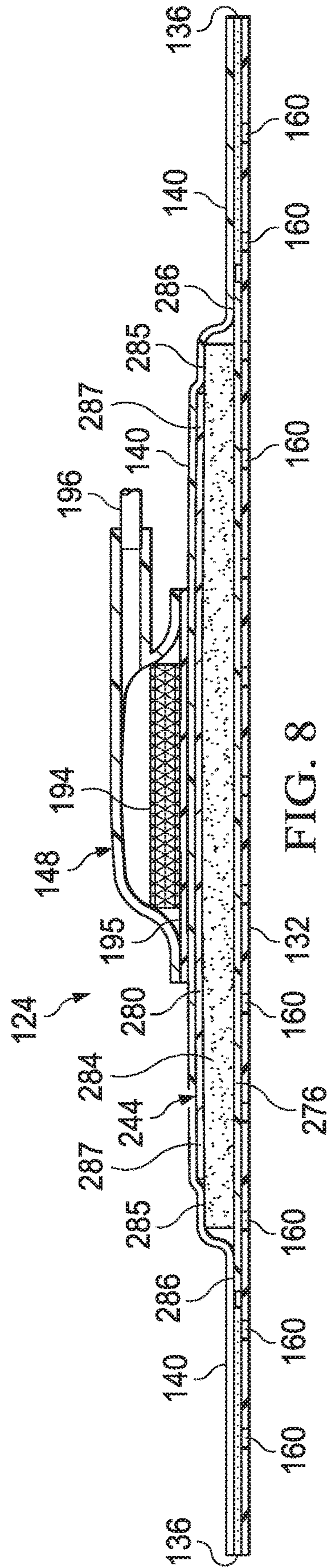

FIG. 8

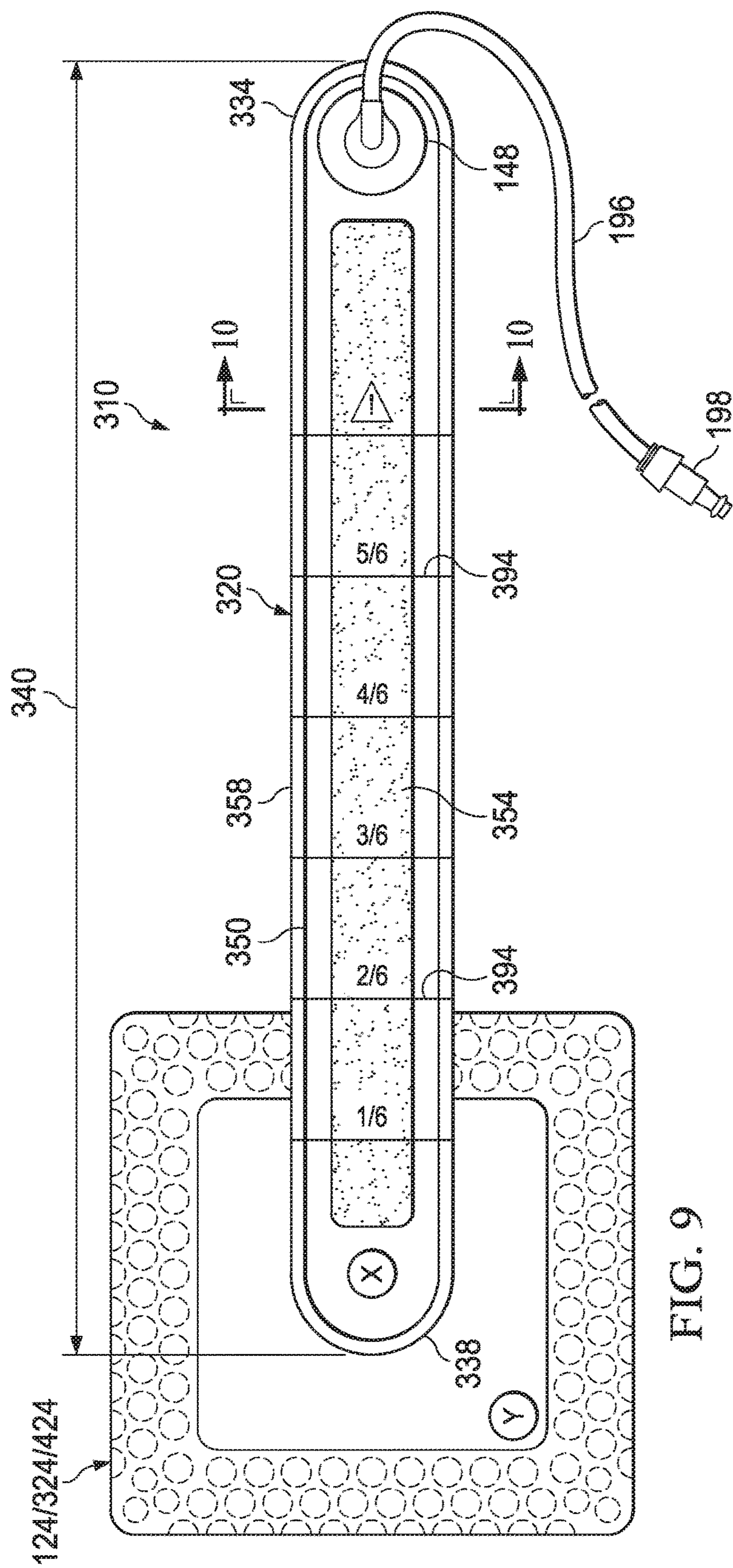

FIG. 9

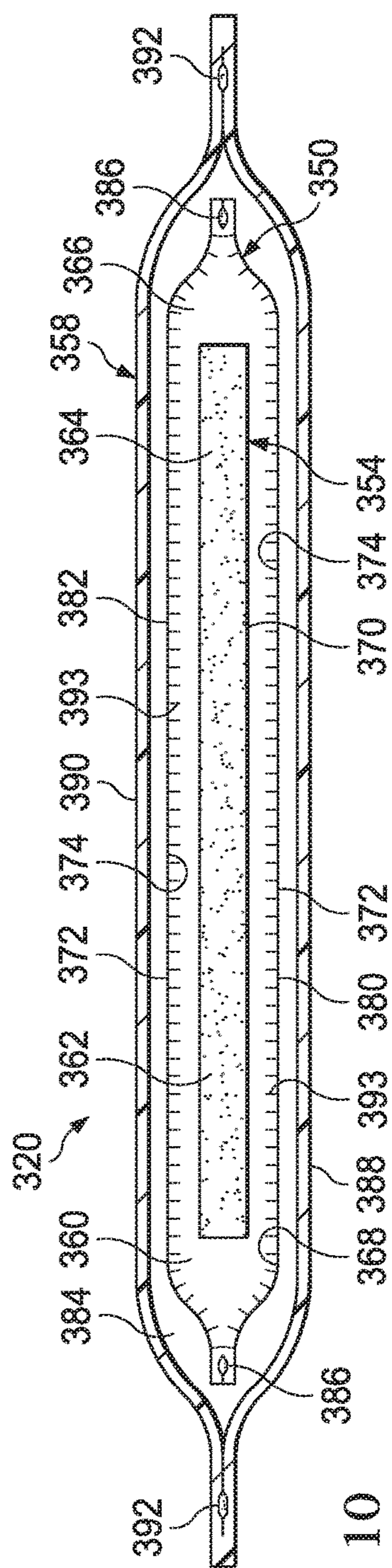

FIG. 10

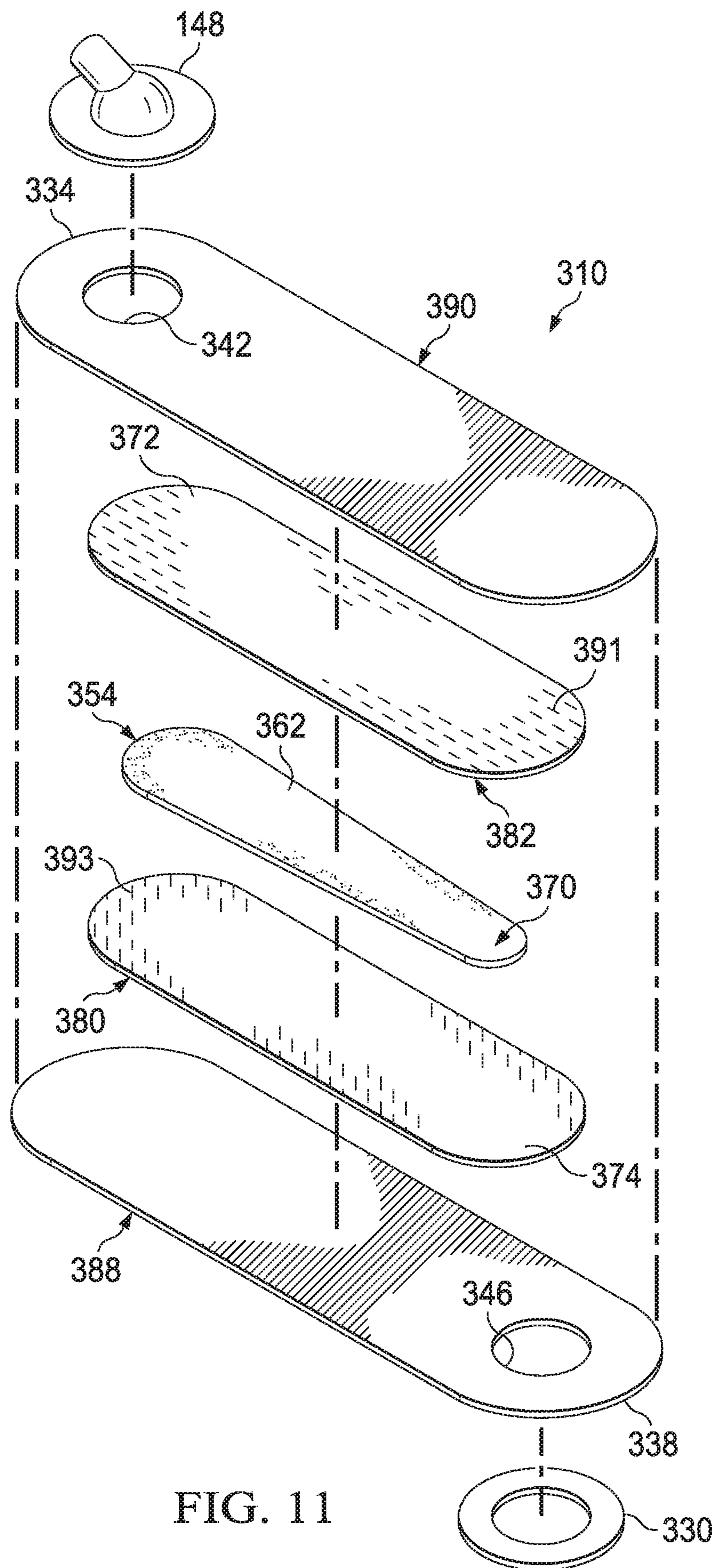
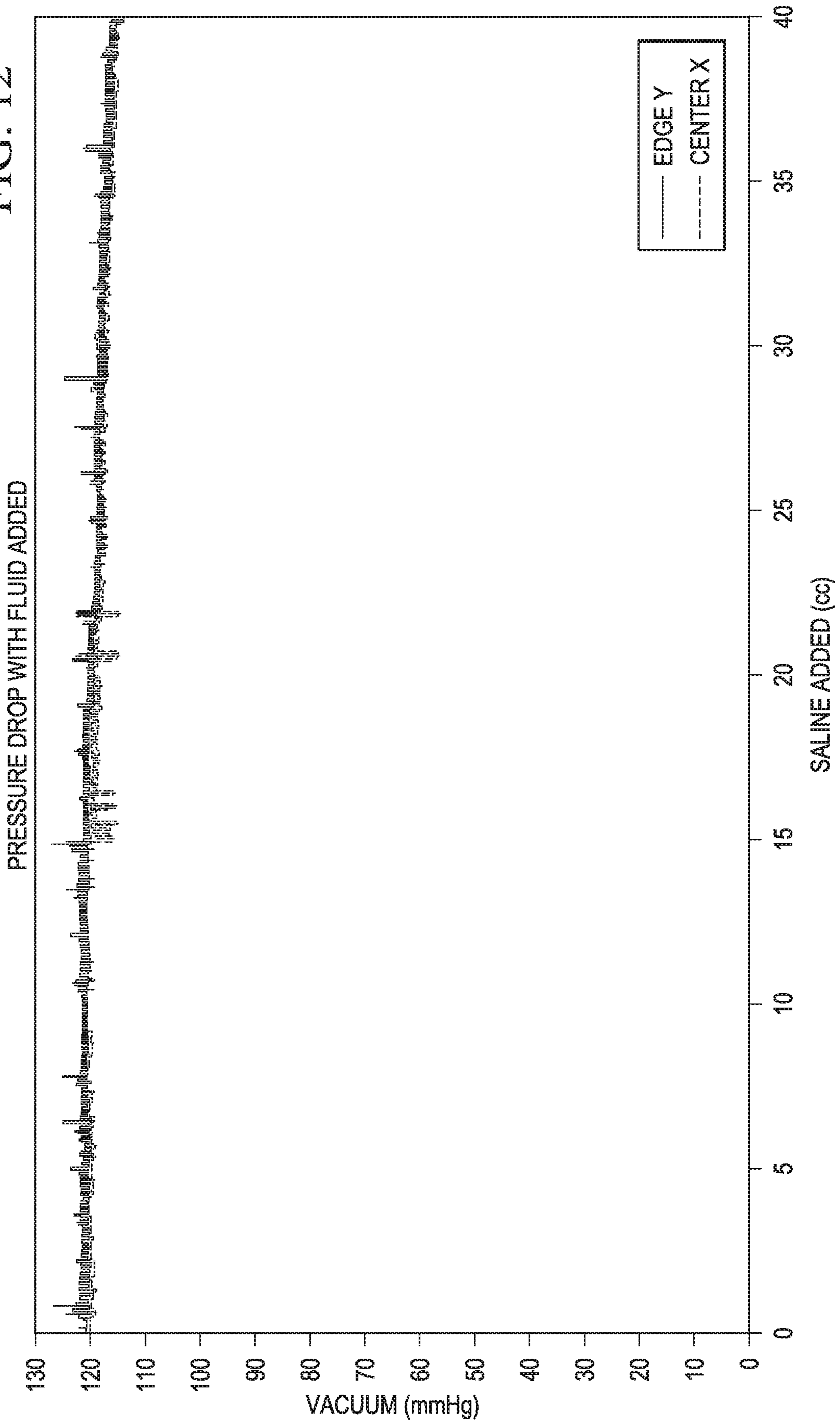

FIG. 11

FIG. 12



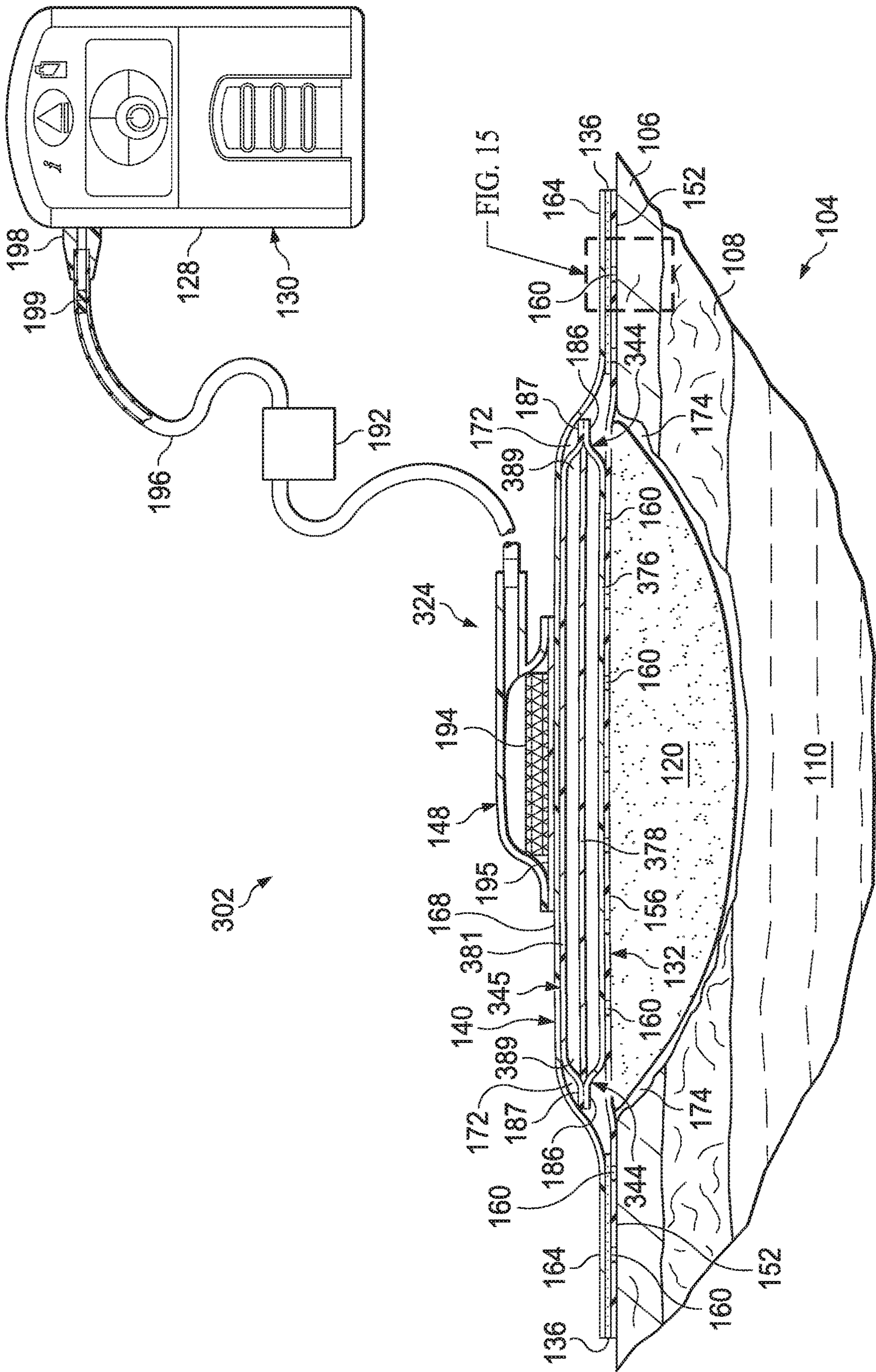

FIG. 13

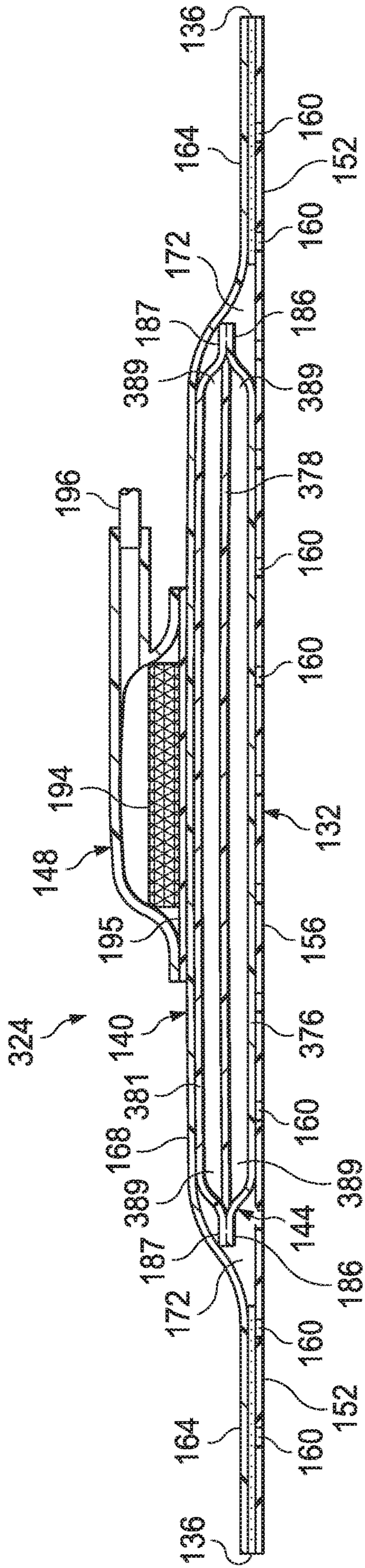

FIG. 14

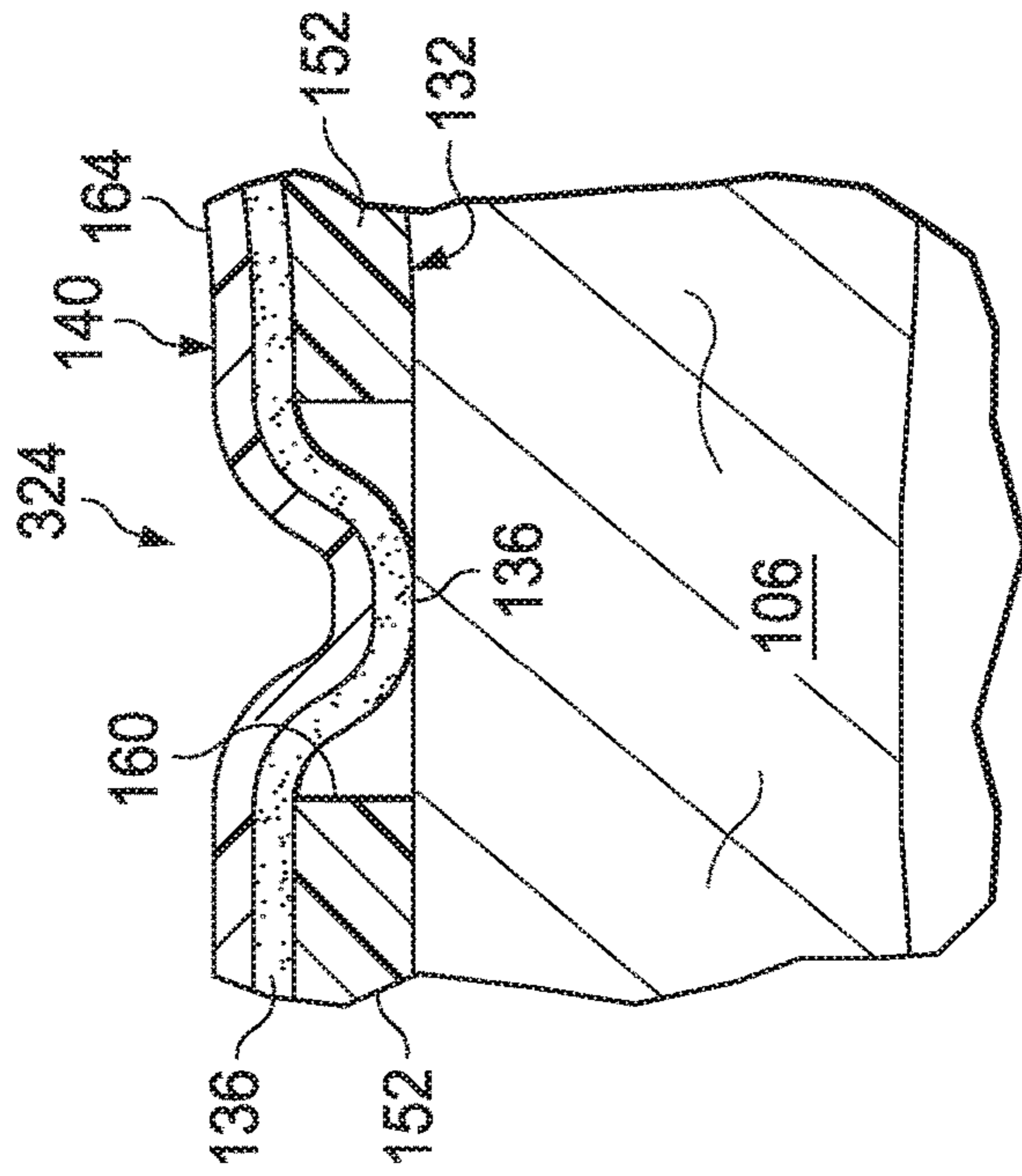

FIG. 15

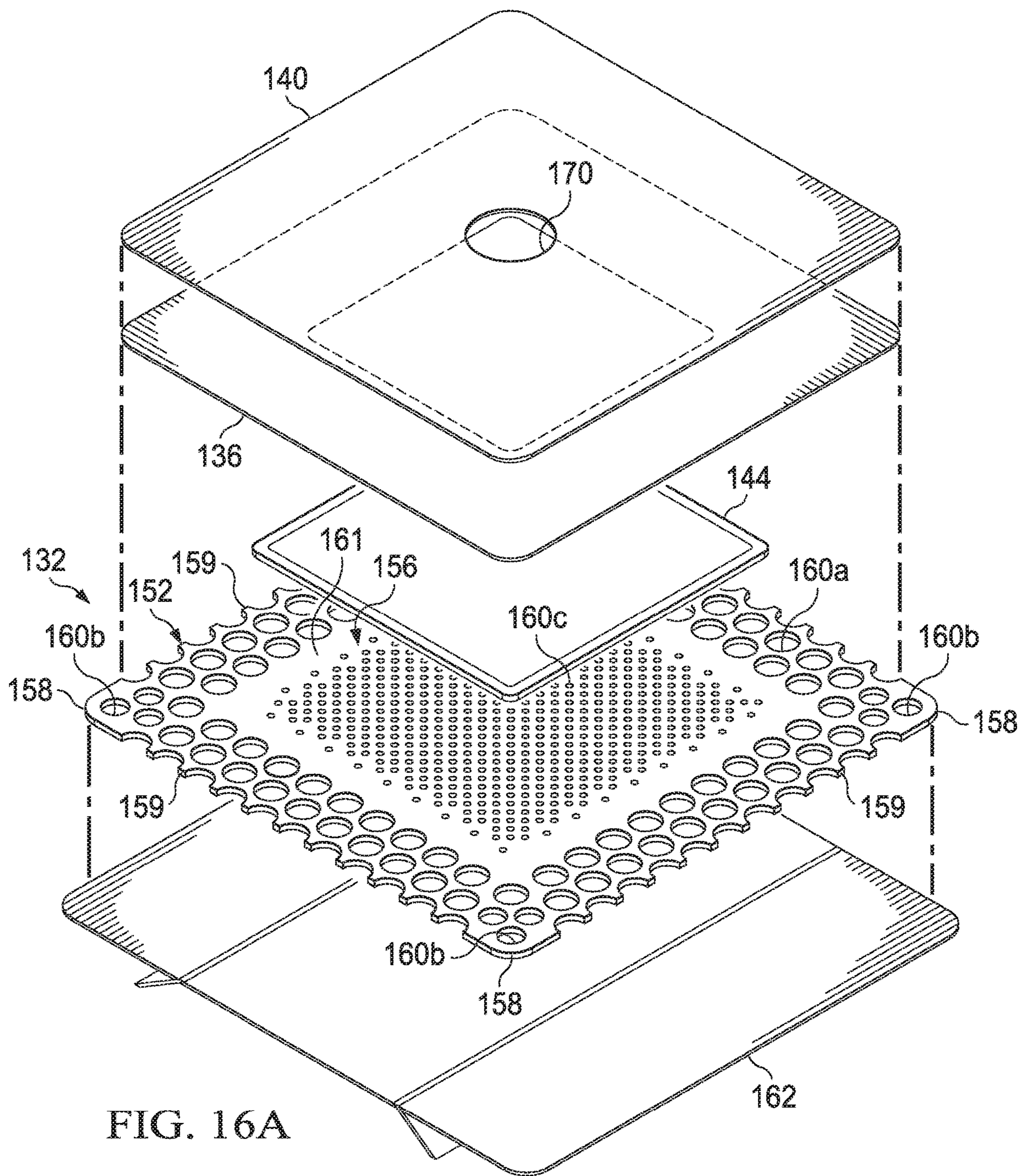

FIG. 16A



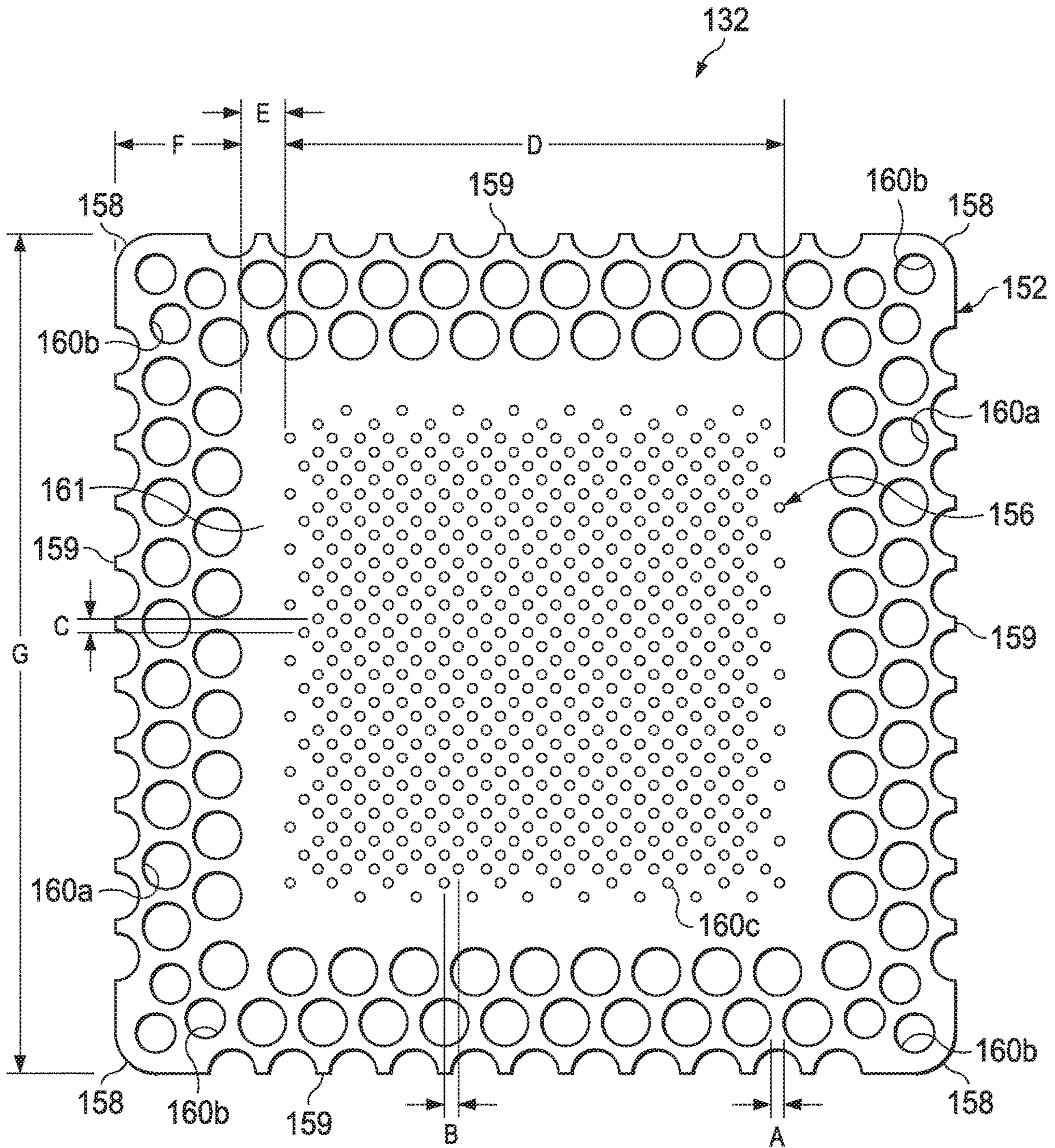

FIG. 16B

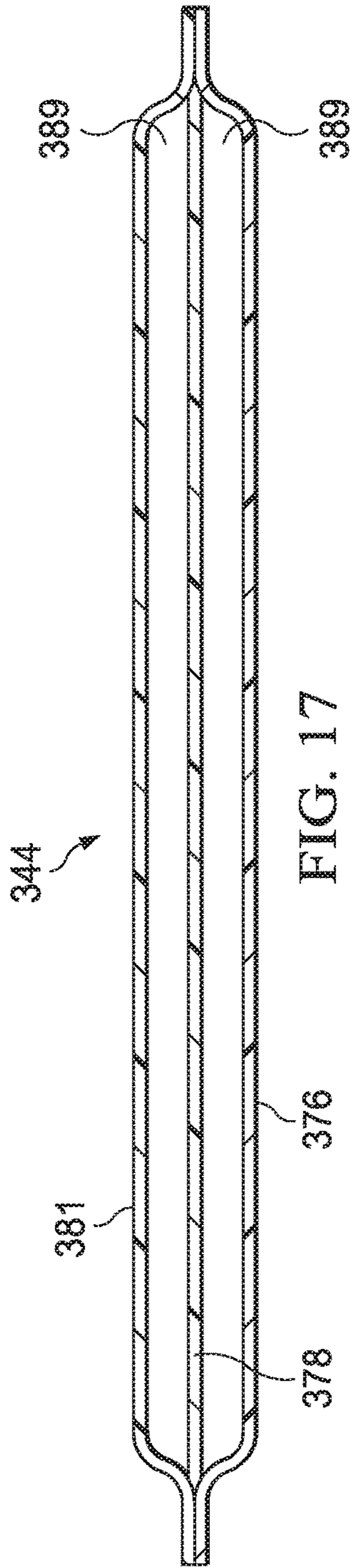

FIG. 17

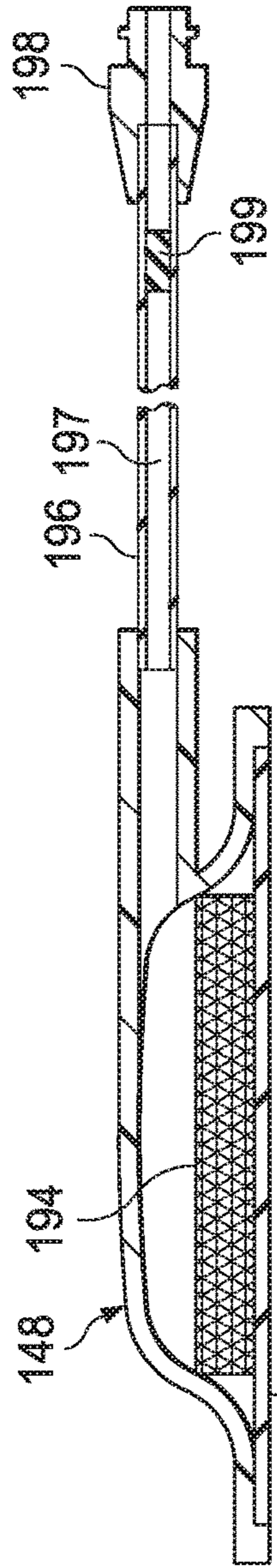

FIG. 18

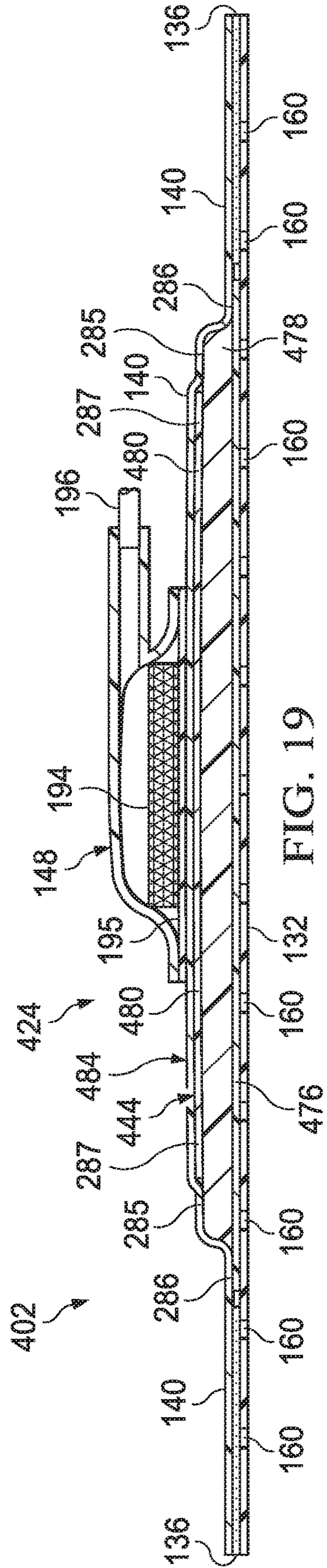

FIG. 19

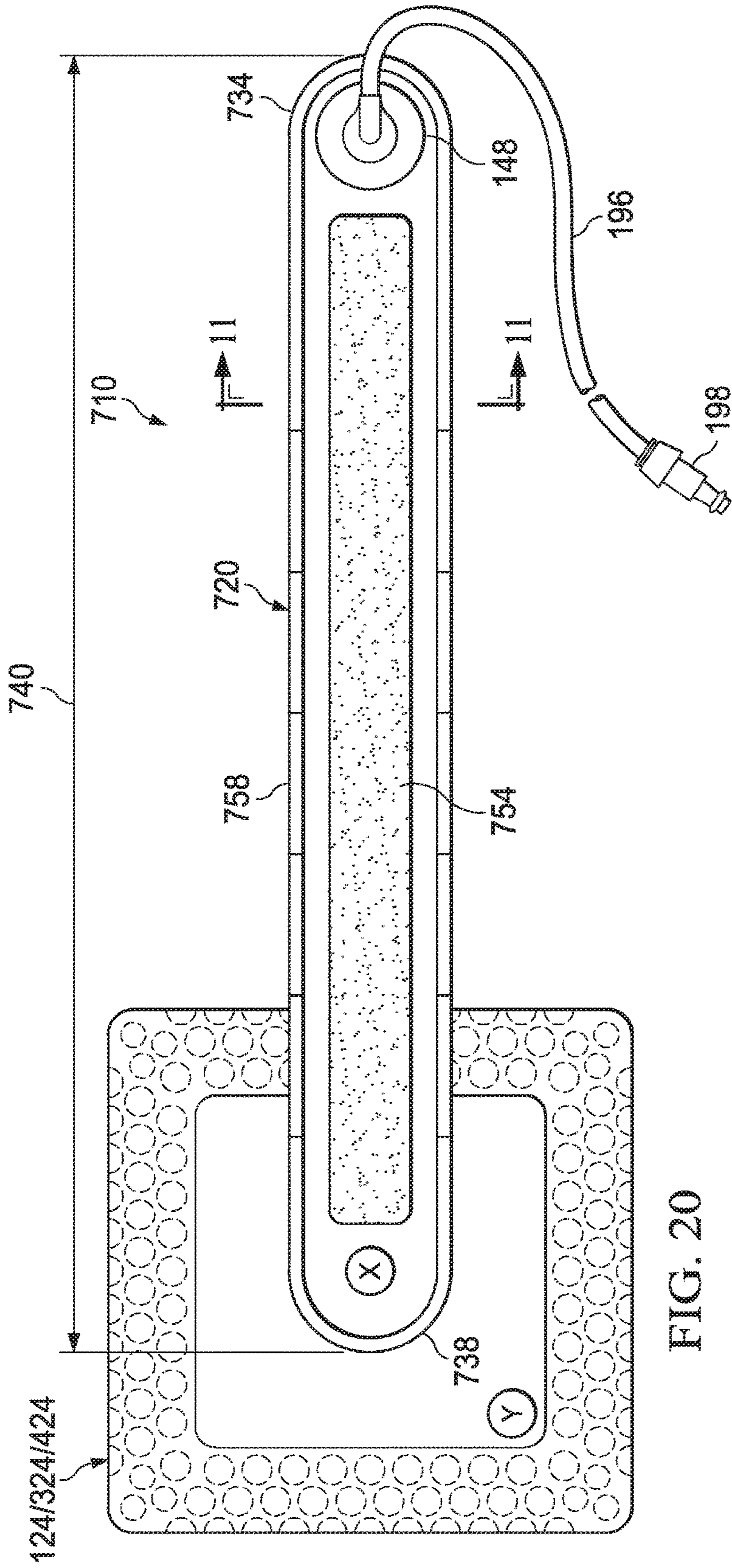

FIG. 20

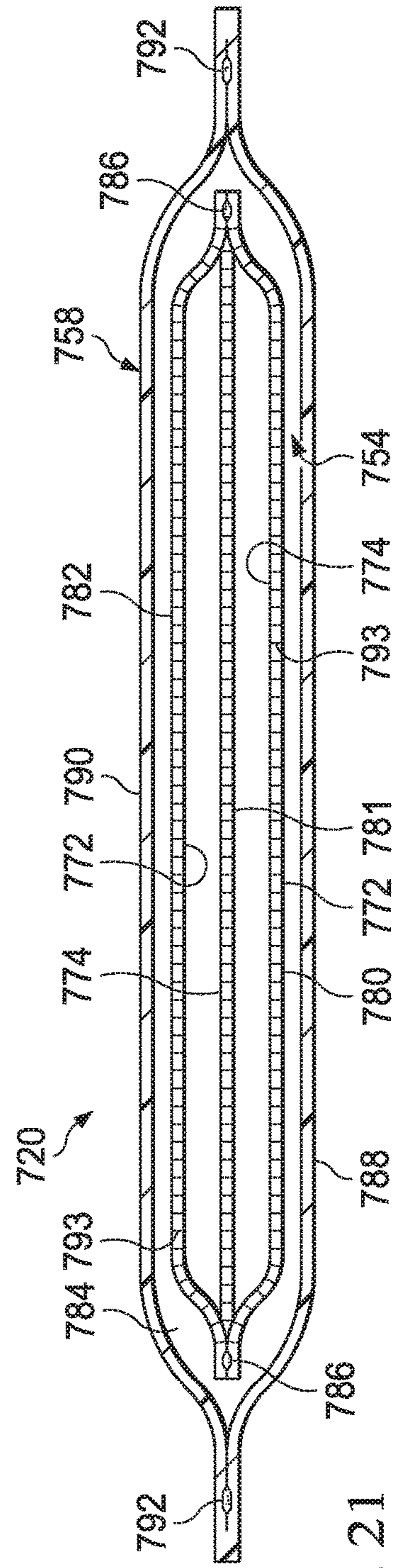

FIG. 21

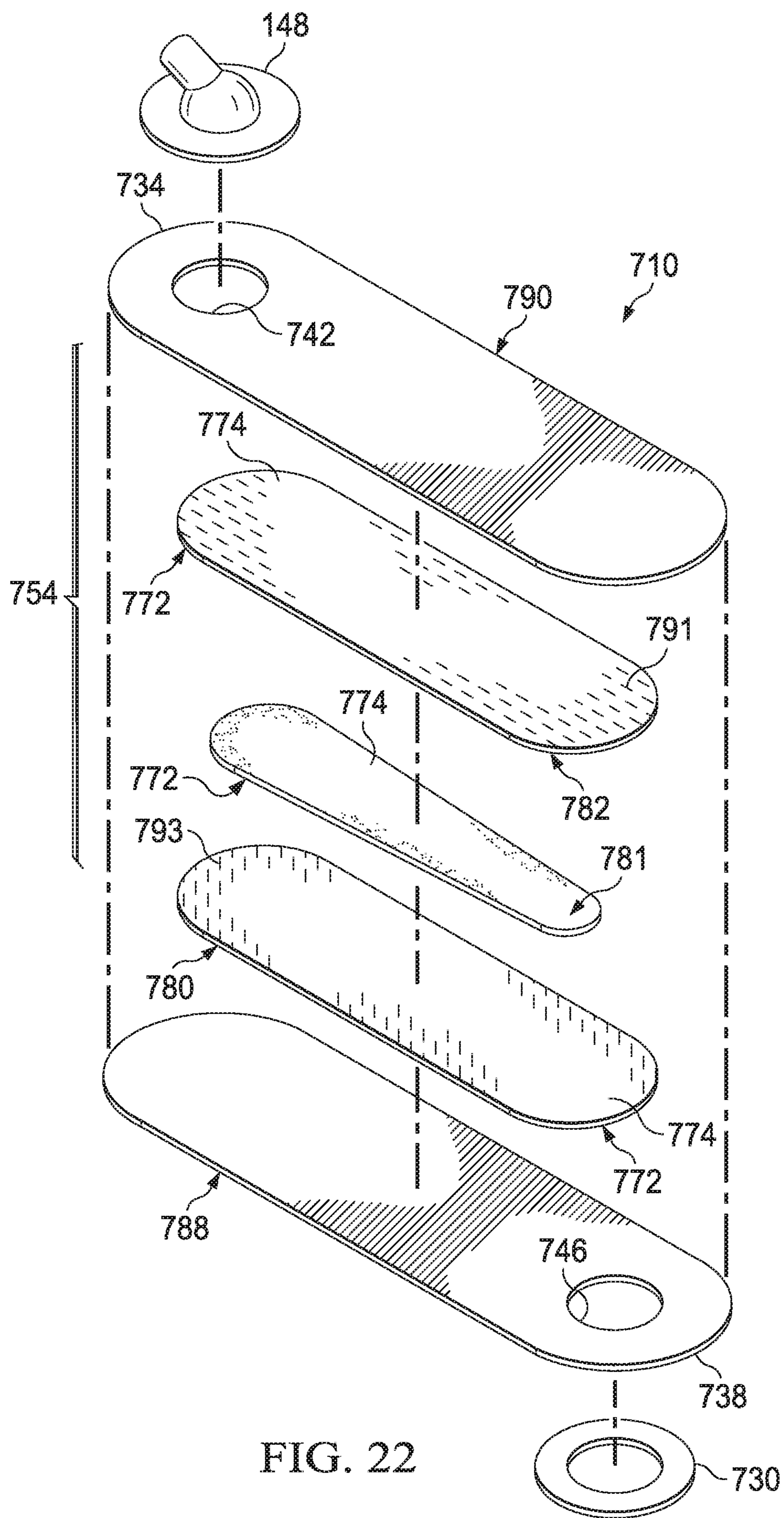

FIG. 22

## MEDICAL SYSTEM AND DRESSING FOR USE UNDER COMPRESSION

### INCORPORATION BY REFERENCE

This application incorporates by reference the following disclosures in their entirety: U.S. Pat. No. 8,814,842, filed Mar. 11, 2011, titled DELIVERY-AND-FLUID-STORAGE BRIDGES FOR USE WITH REDUCED-PRESSURE SYSTEMS; U.S. Patent Publication No. 2014/0012213, filed Dec. 14, 2012, titled RELEASABLE MEDICAL DRAPES; U.S. Patent Publication No. 2015/0119833, filed Sep. 19, 2014, titled DRESSING WITH DIFFERENTIALLY SIZED PERFORATIONS.

### RELATED APPLICATION

The present application is a divisional of U.S. patent application Ser. No. 15/356,063, entitled "MEDICAL SYSTEM AND DRESSING FOR USE UNDER COMPRESSION," filed 18 Nov. 2016, which claims the benefit, under 35 USC § 119(e), of the filing of U.S. Provisional Patent Application Ser. No. 62/257,903, entitled "MEDICAL SYSTEM WITH FLEXIBLE FLUID STORAGE BRIDGE," filed 20 Nov. 2015, which is incorporated herein by reference for all purposes.

### FIELD

This application relates generally to medical treatment systems and, more particularly, but not by way of limitation, to dressings, systems, and methods that may be suitable for treating a tissue site.

### BACKGROUND

Clinical studies and practice have shown that reducing pressure in proximity to a tissue site can augment and accelerate growth of new tissue at the tissue site. The applications of this phenomenon are numerous, but have been proven particularly advantageous for treating wounds. Regardless of the etiology of a wound, whether trauma, surgery, or another cause, proper care of the wound is important to the outcome. Treatment of wounds or other tissue with reduced pressure may be commonly referred to as "reduced-pressure therapy." However, such treatment may also be known by other names including "negative-pressure therapy," "negative-pressure wound therapy," "vacuum therapy," "vacuum-assisted closure," and "topical negative-pressure," for example. Reduced-pressure therapy may provide a number of benefits, including migration of epithelial and subcutaneous tissues, improved blood flow, and micro-deformation of tissue at a tissue site. Together, these benefits can increase development of granulation tissue and reduce healing times. Improvements to therapy systems, components, and processes may benefit manufacturers, healthcare providers, and patients.

### SUMMARY

In some illustrative, non-limiting examples, a bridge assembly for treating a tissue site may include a storage bridge. The storage bridge may include a receiving end and a transmitting end separated by a length. The storage bridge may include a bridge envelope, a bridge absorbent, and a bridge sealing member. The bridge envelope may extend along the length of the storage bridge and may define an

internal volume. The bridge absorbent may be disposed within the internal volume of the bridge envelope. The bridge absorbent may include a volume that is less than the internal volume of the bridge envelope. The bridge sealing member may encapsulate the bridge envelope and may define an internal passageway in fluid communication between the receiving end and the transmitting end.

In some illustrative, non-limiting examples, a storage bridge for treating a tissue site may include a receiving end and a transmitting end separated by a length. Further, the storage bridge may include a bridge envelope, a bridge absorbent, and a bridge sealing member. The bridge envelope may extend along the length of the storage bridge, and may define an internal volume. Further, the bridge envelope may include a fluid acquisition surface and a fluid distribution surface positioned opposite the fluid acquisition surface. The fluid distribution surface may face the internal volume. The bridge absorbent may be disposed within the bridge envelope. At least a portion of the bridge absorbent may be spaced apart from the fluid distribution surface of the bridge envelope. The bridge sealing member may encapsulate the bridge envelope, and may define an internal passageway in fluid communication between the receiving end and the transmitting end.

In some illustrative, non-limiting examples, a storage bridge for treating a tissue site may include a receiving end and a transmitting end separated by a length. Further, the storage bridge may include a first bridge wicking layer, a second bridge wicking layer, a bridge absorbent, and a bridge sealing member. The first bridge wicking layer may extend along the length of the storage bridge, and may comprise a fluid acquisition surface and a fluid distribution surface. The fluid distribution surface may be positioned on an opposite side of the first bridge wicking layer from the fluid acquisition surface. The second bridge wicking layer may extend along the length of the storage bridge, and may comprise a fluid acquisition surface and a fluid distribution surface. The fluid distribution surface may be positioned on an opposite side of the second bridge wicking layer from the fluid acquisition surface. A periphery of the second bridge wicking layer may be coupled to a periphery of the first bridge wicking layer to define an internal volume. The bridge absorbent may be disposed within the internal volume between the first bridge wicking layer and the second bridge wicking layer. The fluid distribution surface of the first wicking layer and the second wicking layer may face the bridge absorbent. The bridge sealing member may include a substantially liquid impermeable and vapor permeable film. Further, the bridge sealing member may define an internal passageway in fluid communication between the receiving end and the transmitting end. The first bridge wicking layer and the second bridge wicking layer may be disposed within the internal passageway.

In some illustrative, non-limiting examples, a system for treating a tissue site may include a dressing, a storage bridge, a conduit interface, and a reduced-pressure source. The dressing may be for positioning at the tissue site, and may include a dressing sealing member and a dressing wicking layer. The dressing sealing member may be adapted to provide a sealed space between the dressing sealing member and the tissue site. The dressing wicking layer may be disposed in the sealed space. The storage bridge may include a receiving end and a transmitting end separated by a length. The transmitting end may be adapted to be fluidly coupled to the dressing. Further, the storage bridge may include a bridge envelope, a bridge absorbent, and a bridge sealing member. The bridge envelope may extend along the length

of the storage bridge, and may define an internal volume. The bridge absorbent may be disposed within the internal volume of the bridge envelope. The bridge sealing member may encapsulate the bridge envelope. The conduit interface may be adapted to be fluidly coupled to the receiving end of the storage bridge. Further, the conduit interface may be in fluid communication with the dressing through the storage bridge. The reduced-pressure source may be adapted to be positioned in fluid communication with the conduit interface.

In some illustrative, non-limiting examples, a system for treating a tissue site may include a dressing, a storage bridge, a conduit interface, and a reduced-pressure source. The dressing may be for positioning at the tissue site, and may include a dressing sealing member and a dressing manifold. The dressing sealing member may be adapted to provide a sealed space between the dressing sealing member and the tissue site. The dressing manifold may be disposed in the sealed space. The storage bridge may include a receiving end and a transmitting end separated by a length. The transmitting end may be adapted to be fluidly coupled to the dressing. Further, the storage bridge may include a bridge envelope, a bridge absorbent, and a bridge sealing member. The bridge envelope may extend along the length of the storage bridge, and may define an internal volume. The bridge absorbent may be disposed within the internal volume of the bridge envelope. The bridge sealing member may encapsulate the bridge envelope. The conduit interface may be adapted to be fluidly coupled to the receiving end of the storage bridge. The conduit interface may be in fluid communication with the dressing through the storage bridge. The reduced-pressure source may be adapted to be positioned in fluid communication with the conduit interface.

In some illustrative, non-limiting examples, a system for treating a tissue site may include a dressing, a storage bridge, a conduit interface, and a manual pump. The dressing may be for positioning at the tissue site, and may include a dressing sealing member and a dressing manifold. The dressing sealing member may be adapted to provide a sealed space between the dressing sealing member and the tissue site. The dressing manifold may be disposed in the sealed space. The storage bridge may include a receiving end and a transmitting end separated by a length. The transmitting end may be adapted to be fluidly coupled to the dressing. Further, the storage bridge may include a bridge envelope, a bridge absorbent, and a bridge sealing member. The bridge envelope may extend along the length of the storage bridge, and may define an internal volume. The bridge absorbent may be disposed within the internal volume of the bridge envelope. The bridge absorbent may have a volume that is at least 5 percent less than the internal volume of the bridge envelope. The bridge sealing member may encapsulate the bridge envelope. The conduit interface may be adapted to be fluidly coupled to the receiving end of the storage bridge. The conduit interface may be in fluid communication with the dressing through the storage bridge. The manual pump may be adapted to be positioned in fluid communication with the conduit interface.

In some illustrative, non-limiting examples, a method of treating a tissue site may include positioning a dressing at the tissue site. Further, the method may include fluidly coupling a transmitting end of a storage bridge to the dressing, and fluidly coupling a manual pump to a receiving end of the storage bridge. Further, the method may include manually activating the manual pump to cause fluid to move from the tissue site to the storage bridge through the dressing. Further, the method may include storing at least a

portion of the fluid in the storage bridge. At least a portion of the fluid may be a liquid. Further, the method may include indicating a level of the fluid stored in the storage bridge with a plurality of fluid capacity indicators positioned along a length of the storage bridge.

In some illustrative, non-limiting examples, a system for treating a tissue site may include a dressing, a bridge, a conduit interface, and a reduced-pressure source. The dressing may be for positioning at the tissue site, and may include a dressing sealing member and one or more dressing wicking layers. The dressing sealing member may be adapted to provide a sealed space between the dressing sealing member and the tissue site. The one or more dressing wicking layers may be disposed in the sealed space. The bridge may include a receiving end and a transmitting end separated by a length. The transmitting end may be adapted to be fluidly coupled to the dressing. Further, the bridge may include a bridge sealing member, and one or more wicking members. The bridge sealing member may extend along the length, and may define an internal volume. The one or more bridge wicking layers may be disposed within the internal volume of the bridge sealing member. The conduit interface may be adapted to be fluidly coupled to the receiving end of the bridge. The conduit interface may be in fluid communication with the dressing through the bridge. The reduced-pressure source may be adapted to be positioned in fluid communication with the conduit interface.

In some examples, the bridge may additionally or alternatively include a bridge absorbent disposed within the internal volume of the bridge sealing member. The one or more dressing wicking layers may include at least a first dressing wicking layer, a second dressing wicking layer, and a third dressing wicking layer. In some embodiments, the one or more dressing wicking layers may include a first dressing wicking layer and a second dressing wicking layer. In some examples, a peripheral portion of the first dressing wicking layer is coupled to a peripheral portion of the third dressing wicking layer providing a wicking layer enclosure. The dressing may additionally or alternatively include a base layer and an adhesive. The base layer may have a periphery surrounding a central portion and a plurality of apertures disposed through the periphery and the central portion. The adhesive may be in fluid communication with the plurality of apertures at least in the periphery of the base layer. In some examples, the dressing sealing member may include a periphery and a central portion. The periphery of the dressing sealing member may be positioned proximate to the periphery of the base layer. The central portion of the dressing sealing member and the central portion of the base layer may define an enclosure. The one or more dressing wicking layers may be disposed in the enclosure. The dressing may additionally or alternatively include a base layer adapted to be positioned in contact with the tissue site. The base layer may include a non-adherent mesh. The one or more dressing wicking layers may be positioned between the base layer and the dressing sealing member.

In some examples, the one or more bridge wicking layers may include a first bridge wicking layer and a second bridge wicking layer. The first bridge wicking layer may have a surface area that is greater than a surface area of the second bridge wicking layer. The first bridge wicking layer may have a density that is greater than a density of the second bridge wicking layer. The first bridge wicking layer may be adapted to be positioned underneath the second bridge wicking layer.

In some examples, the one or more bridge wicking layers may include a fluid acquisition surface and a fluid distribu-

5

tion surface positioned opposite the fluid acquisition surface. The fluid distribution surface may face the internal volume of the bridge sealing member. The fluid distribution surface may include a plurality of longitudinal fibers oriented substantially in a longitudinal direction along the length of the bridge. The fluid acquisition surface may include a plurality of vertical fibers oriented substantially normal relative to the longitudinal fibers. The bridge sealing member may sealingly enclose the one or more bridge wicking layers between the receiving end and the transmitting end of the bridge. The bridge sealing member may include a substantially liquid impermeable and vapor permeable film. The system may additional or alternatively include a sealing apparatus adapted to be positioned about a transmitting end aperture and between the transmitting end and the dressing.

In some illustrative, non-limiting examples, a system for treating a tissue site may include a dressing, a bridge, a conduit interface, and a reduced-pressure source. The dressing may be for positioning at the tissue site, and may include a dressing sealing member and a dressing manifold. The dressing sealing member may be adapted to provide a sealed space between the dressing sealing member and the tissue site. The dressing manifold may be disposed in the sealed space. The bridge may include a receiving end and a transmitting end separated by a length. The transmitting end may be adapted to be fluidly coupled to the dressing. Further, the bridge may include a bridge sealing member, and one or more wicking members. The bridge sealing member may extend along the length, and may define an internal volume. The one or more bridge wicking layers may be disposed within the internal volume of the bridge sealing member. The conduit interface may be adapted to be fluidly coupled to the receiving end of the bridge. The conduit interface may be in fluid communication with the dressing through the bridge. The reduced-pressure source may be adapted to be positioned in fluid communication with the conduit interface.

In some illustrative, non-limiting examples, a system for treating a tissue site may include a dressing, a bridge, a conduit interface, and a manual pump. The dressing may be for positioning at the tissue site, and may include a dressing sealing member and one or more dressing wicking layers. The dressing sealing member may be adapted to provide a sealed space between the dressing sealing member and the tissue site. The one or more dressing wicking layers may be disposed in the sealed space. The bridge may include a receiving end and a transmitting end separated by a length. The transmitting end may be adapted to be fluidly coupled to the dressing. Further, the bridge may include a bridge sealing member, and one or more wicking members. The bridge sealing member may extend along the length, and may define an internal volume. The one or more bridge wicking layers may be disposed within the internal volume of the bridge sealing member. The conduit interface may be adapted to be fluidly coupled to the receiving end of the bridge. The conduit interface may be in fluid communication with the dressing through the bridge. The manual pump may be adapted to be positioned in fluid communication with the conduit interface.

In some illustrative, non-limiting examples, a method of treating a tissue site may include positioning a dressing at the tissue site. Further, the method may include fluidly coupling a transmitting end of a bridge to the dressing, and fluidly coupling a manual pump to a receiving end of the bridge. Further, the method may include manually activating the manual pump to cause fluid to move from the tissue site to the bridge through one or more dressing wicking layers of

6

the dressing and to cause fluid to move through one or more bridge wicking layers of the bridge to the manual pump. Further, the method may include storing at least a portion of the fluid in the manual pump. At least a portion of the fluid may be a liquid.

In some illustrative, non-limiting examples, a bridge assembly for treating a tissue site may include a bridge. The bridge may include a receiving end and a transmitting end separated by a length. The bridge may include a bridge sealing member, and one or more bridge wicking layers. The bridge sealing member may extend along the length of the bridge and may define an internal passageway in fluid communication between the receiving end and the transmitting end. The one or more bridge wicking layers may be disposed within the internal passageway. The one or more bridge wicking layers may be configured to communicate fluid between the receiving end and the transmitting end of the bridge.

In some examples, the bridge assembly may alternatively or additionally include a bridge absorbent disposed within the internal passageway. The bridge absorbent may include a volume that is less than a volume of the internal passageway. The bridge assembly may alternatively or additionally include a conduit interface adapted to be fluidly coupled to the receiving end of the bridge. The conduit interface may be in fluid communication with the transmitting end through the bridge. The bridge assembly may alternatively or additionally include a fluid capacity indicator positioned along the length of the bridge. The bridge sealing member may encapsulate the one or more bridge wicking layers. The bridge sealing member may include a non-woven material. The one or more bridge wicking layers may be moveable within the internal passageway.

The one or more bridge wicking layers may include a first bridge wicking layer, a second bridge wicking layer, a third bridge wicking layer. A periphery of the first bridge wicking layer may be coupled to a periphery of the third bridge wicking layer. The second bridge wicking layer may be positioned between the first bridge wicking layer and the third bridge wicking layer. Each of the one or more bridge wicking layers may be comprised of a non-woven material. Each of the one or more bridge wicking layers may include a fluid acquisition surface and a fluid distribution surface positioned opposite the fluid acquisition surface. The fluid distribution surface of each of the one or more bridge wicking layers may face a first direction. The fluid acquisition surface of each of the one or more bridge wicking layers may face a second direction. The bridge sealing member may entirely surround the one or more bridge wicking layers. The bridge sealing member may include a substantially liquid impermeable film. The bridge sealing member may be a vapor permeable film. The bridge sealing member may include a breathable film. The bridge sealing member may include a first sealing layer and a second sealing layer. A periphery of the first sealing layer may be coupled to a periphery of the second sealing layer around the one or more bridge wicking layers.

In some examples, the one or more bridge wicking layers may include a first bridge wicking layer and a second bridge wicking layer. The first bridge wicking layer may have a surface area that is greater than a surface area of the second bridge wicking layer. The first bridge wicking layer may have a density that is greater than a density of the second bridge wicking layer. The first bridge wicking layer may be adapted to be positioned underneath the second bridge wicking layer.

In some illustrative, non-limiting examples, a bridge for treating a tissue site may include a receiving end and a transmitting end separated by a length. Further, the bridge may include a bridge sealing member, and one or more bridge wicking layers. The bridge sealing member may extend along the length of the bridge, and may define an internal passageway in fluid communication between the receiving end and the transmitting end. Further, the bridge sealing member may include a first sealing layer and a second sealing layer positioned opposite the first sealing layer. The one or more bridge wicking layers may be disposed within the bridge sealing member. At least a portion of the one or more bridge wicking layers may be spaced apart from the bridge sealing member. The one or more bridge wicking layers may include a first bridge wicking layer and a second bridge wicking layer. The first bridge wicking layer may have a surface area that is greater than a surface area of the second bridge wicking layer. The first bridge wicking layer may have a density that is greater than a density of the second bridge wicking layer. The first bridge wicking layer may be adapted to be positioned underneath the second bridge wicking layer.

In some examples, the bridge may additionally or alternatively include an absorbent disposed within the bridge sealing member. At least a portion of the absorbent may be spaced apart from the first sealing layer and the second sealing layer of the bridge sealing member. The bridge sealing member may entirely surround the one or more bridge wicking layers. The one or more bridge wicking layers may include a first bridge wicking layer, a second bridge wicking layer, and a third bridge wicking layer. A periphery of the first bridge wicking layer may be coupled to a periphery of the third bridge wicking layer. The second bridge wicking layer may be disposed between the first bridge wicking layer and the third bridge wicking layer. Each of the one or more bridge wicking layers may include of a non-woven material. Each of the one or more bridge wicking layers may include a fluid acquisition surface and a fluid distribution surface positioned opposite the fluid acquisition surface. The fluid distribution surface of each of the one or more bridge wicking layers may face a first direction. The fluid acquisition surface of each of the one or more bridge wicking layers may face a second direction. The bridge sealing member may include a substantially liquid impermeable and vapor permeable film.

In some illustrative, non-limiting examples, a bridge for treating a tissue site may include a receiving end and a transmitting end separated by a length. Further, the bridge may include a first set of one or more bridge wicking layers, a second set of one or more bridge wicking layers, and a bridge sealing member. The first set of one or more bridge wicking layers may extend along the length of the bridge, and may include a fluid acquisition surface and a fluid distribution surface. The fluid distribution surface may be positioned on an opposite side of at least one bridge wicking layer of the first set of one or more bridge wicking layers from the fluid acquisition surface. The second set of one or more bridge wicking layers may extend along the length of the storage bridge, and may include a fluid acquisition surface and a fluid distribution surface. The fluid distribution surface may be positioned on an opposite side of at least one bridge wicking layer of the second set of one or more bridge wicking layers from the fluid acquisition surface. A periphery of at least one bridge wicking layer of the second set of one or more bridge wicking layers may be coupled to a periphery of at least one bridge wicking layer of the first set of one or more bridge wicking layers to define an internal

volume. The bridge sealing member may include a substantially liquid impermeable and vapor permeable film. Further, the bridge sealing member may define an internal passageway in fluid communication between the receiving end and the transmitting end. The first set of one or more bridge wicking layers and the second set of one or more bridge wicking layers may be disposed within the internal passageway.

In some embodiments, the bridge may alternatively or additionally a bridge absorbent disposed within the internal volume between the first set of one or more bridge wicking layers and the second set of one or more bridge wicking layers. The fluid distribution surface of the at least one bridge wicking layer of the first set of one or more bridge wicking layers and the at least one bridge wicking layer of the second set of one or more bridge wicking layers may face the bridge absorbent. At least a portion of the bridge absorbent may be spaced apart from the fluid distribution surface of the at least one bridge wicking layer of the first set of one or more bridge wicking layers and the at least one bridge wicking layer of the second set of one or more bridge wicking layers. The fluid distribution surface of the at least one bridge wicking layer of the first set of one or more bridge wicking layers and the at least one bridge wicking layer of the second set of one or more bridge wicking layers may include a plurality of longitudinal fibers oriented substantially in a longitudinal direction along the length. The fluid acquisition surface of the at least one bridge wicking layer of the first set of one or more bridge wicking layers and the at least one bridge wicking layer of the second set of one or more bridge wicking layers may include a plurality of vertical fibers oriented substantially normal relative to the longitudinal fibers.

In some illustrative, non-limiting examples, a bridge for treating a tissue site may include a receiving end and a transmitting end separated by a length. Further, the bridge may include a first bridge wicking layer, a second bridge wicking layer, and a bridge sealing member. The first bridge wicking layer may extend along the length of the bridge, and may include a fluid acquisition surface and a fluid distribution surface. The fluid distribution surface may be positioned on an opposite side of the first bridge wicking layer from the fluid acquisition surface. The second bridge wicking layer may extend along the length of the storage bridge, and may include a fluid acquisition surface and a fluid distribution surface. The fluid distribution surface may be positioned on an opposite side of the second bridge wicking layer from the fluid acquisition surface. A periphery of the second bridge wicking layer may be coupled to a periphery of the first bridge wicking layer to define an internal volume. The bridge sealing member may include a substantially liquid impermeable and vapor permeable film. Further, the bridge sealing member may define an internal passageway in fluid communication between the receiving end and the transmitting end. The first bridge wicking layer and the second bridge wicking layer may be disposed within the internal passageway.

In some embodiments, the bridge may alternatively or additionally a bridge absorbent disposed within the internal volume between the first bridge wicking layer and the second bridge wicking layer. The fluid distribution surface of the first bridge wicking layer and the second bridge wicking layer may face the bridge absorbent. At least a portion of the bridge absorbent may be spaced apart from the fluid distribution surface of the first bridge wicking layer and the second bridge wicking layer. The fluid distribution surface of the first bridge wicking layer and the second



bridge wicking layer may include a plurality of longitudinal fibers oriented substantially in a longitudinal direction along the length. The fluid acquisition surface of the first bridge wicking layer and the second bridge wicking layer may include a plurality of vertical fibers oriented substantially normal relative to the longitudinal fibers.

Other aspects, features, and advantages of the illustrative examples will become apparent with reference to the drawings and detailed description that follow.

#### BRIEF DESCRIPTION OF THE DRAWINGS

FIG. 1 is a cut-away view of an illustrative example of a system for treating a tissue site depicting an illustrative example of a dressing deployed at the tissue site;

FIG. 2 is a cut-away view of the dressing of FIG. 1;

FIG. 3 is detail view taken at reference FIG. 3, shown in FIG. 1, illustrating the dressing of FIG. 1 positioned proximate to tissue surrounding the tissue site;

FIG. 4A is an exploded view of the dressing of FIG. 1, depicted without a conduit interface and with an illustrative example of a release liner for protecting the dressing prior to application at the tissue site;

FIG. 4B is a plan view of an illustrative example of a base layer depicted in the dressing of FIG. 4A;

FIG. 5 is a cut-away view of an illustrative example of a fluid management assembly suitable for use with the dressing and system of FIG. 1;

FIG. 6 is a cut-away view of another illustrative example of a fluid management assembly suitable for use with the dressing and system of FIG. 1;

FIG. 7 is a cut-away view of an illustrative example of a conduit interface shown with the dressing of FIG. 1;

FIG. 8 is a cut-away view of another illustrative example of a dressing and a fluid management assembly suitable for use with the system of FIG. 1;

FIG. 9 is a plan view of an illustrative example of a bridge assembly suitable for use with the system and the dressing of FIG. 1;

FIG. 10 is a cross-section of an illustrative example of a storage bridge shown with the bridge assembly of FIG. 9, taken at lines 10-10;

FIG. 11 is an exploded view of the bridge assembly of FIG. 9;

FIG. 12 is a graph illustrating reduced pressure communication to a dressing through a bridge assembly according to this disclosure during application of fluid to the dressing;

FIG. 13 is a cut-away view of an illustrative example of a system for treating a tissue site depicting another illustrative example of a dressing deployed at the tissue site;

FIG. 14 is a cut-away view of the dressing of FIG. 13;

FIG. 15 is a detail view taken at reference FIG. 15, shown in FIG. 13, illustrating the dressing of FIG. 13 positioned proximate to tissue surrounding the tissue site;

FIG. 16A is an exploded view of the dressing of FIG. 13, depicted without a conduit interface and with an illustrative example of a release liner for protecting the dressing prior to application at the tissue site;

FIG. 16B is a plan view of an illustrative example of a base layer depicted in the dressing of FIG. 16A;

FIG. 17 is a cut-away view of an illustrative example of a fluid management assembly suitable for use with the dressing and system of FIG. 13;

FIG. 18 is a cut-away view of an illustrative example of a conduit interface shown with the dressing of FIG. 13;

FIG. 19 is a cut-away view of another illustrative example of a dressing and a fluid management assembly suitable for use with the system of FIG. 13;

FIG. 20 is a plan view of an illustrative example of a bridge assembly suitable for use with the system and the dressing of FIG. 13;

FIG. 21 is a cross-section of an illustrative example of a bridge shown with the bridge assembly of FIG. 20, taken at lines 11-11; and

FIG. 22 is an exploded view of the bridge assembly of FIG. 20.

#### DETAILED DESCRIPTION OF ILLUSTRATIVE EMBODIMENTS

In the following detailed description of illustrative example embodiments, reference is made to the accompanying drawings that form a part of this disclosure. Other embodiments may be used, and logical, structural, mechanical, electrical, and chemical changes may be made without departing from the scope of this disclosure. Further, the description may omit certain information known to those skilled in the art. Therefore, the following detailed description is non-limiting, and the appended claims define the scope of the illustrative embodiments. Further, as used throughout this disclosure, “or” does not require mutual exclusivity.

Referring to the drawings, FIG. 1 depicts an illustrative embodiment of a system 102 for treating a tissue site 104 of a patient. The tissue site 104 may extend through or otherwise involve an epidermis 106, a dermis 108, and a subcutaneous tissue 110. The tissue site 104 may be a sub-surface tissue site as depicted in FIG. 1 that may extend below the surface of the epidermis 106. Further, the tissue site 104 may be a surface tissue site (not shown) that may predominantly reside on the surface of the epidermis 106, such as, for example, an incision. The system 102 may provide therapy to, for example, the epidermis 106, the dermis 108, and the subcutaneous tissue 110, regardless of the positioning of the system 102 or the type of tissue site. The system 102 may also be used without limitation at other tissue sites.

The tissue site 104 may be the bodily tissue of any human, animal, or other organism, including bone tissue, adipose tissue, muscle tissue, dermal tissue, vascular tissue, connective tissue, cartilage, tendons, ligaments, or any other tissue. Treatment of the tissue site 104 may include the removal of fluids, such as exudate or ascites.

Continuing with FIG. 1, the system 102 may include an optional tissue interface, such as an interface manifold 120. Further, the system 102 may include a dressing 124 and a reduced-pressure source 128. The reduced-pressure source 128 may be a component of an optional therapy unit 130. In some embodiments, the reduced-pressure source 128 and the therapy unit 130 may be separate components. Further, in some embodiments, the interface manifold 120 may be omitted for different types of tissue sites or different types of therapy, such as, for example, epithelialization. If equipped, the interface manifold 120 may be adapted to be positioned proximate to or adjacent to the tissue site 104, such as, for example, by cutting or otherwise shaping the interface manifold 120 in any suitable manner to fit the tissue site 104. As described below, the interface manifold 120 may be adapted to be positioned in fluid communication with the tissue site 104 to distribute reduced pressure to the tissue site 104. In some embodiments, the interface manifold 120 may be positioned in direct contact with the tissue site 104.

## 11

The tissue interface or the interface manifold **120** may be formed from any manifold material or flexible bolster material that provides a vacuum space, or treatment space, such as, for example, a porous and permeable foam or foam-like material, a member formed with pathways, a graft, or a gauze. In some embodiments, the interface manifold **120** may be a reticulated, open-cell polyurethane or polyether foam that may be fluid permeable while under a reduced pressure. One such foam material is VAC® GranuFoam® material available from Kinetic Concepts, Inc. (KCI) of San Antonio, Tex. Further, in some embodiments, any material or combination of materials may be used as a manifold material for the interface manifold **120** provided that the manifold material is operable to distribute or collect fluid. For example, herein the term manifold may refer to a substance or structure configured for delivering fluids to or removing fluids from a tissue site through a plurality of pores, pathways, or flow channels. The plurality of pores, pathways, or flow channels may be interconnected to improve the distribution of fluids provided to and removed from an area around the manifold. Examples of manifolds may include, without limitation, devices that have structural elements arranged to form flow channels, cellular foam, such as open-cell foam, porous tissue collections, and liquids, gels, and foams that include or cure to include flow channels.

In some embodiments, a material with a higher or lower density than GranuFoam® material may be desirable for the interface manifold **120** depending on the application. Among the many possible materials, the following may be used without limitation: GranuFoam® material; Foamex® technical foam (www.foamex.com); a molded bed of nails structure; a patterned grid material, such as those manufactured by Sercol Industrial Fabrics; 3D textiles, such as those manufactured by Baltex of Derby, U.K.; a gauze; a flexible channel-containing member; or a graft. Further, in some embodiments, ionic silver may be added to the interface manifold **120** by, for example, a micro bonding process. Other substances, such as anti-microbial agents, may be added to the interface manifold **120** as well.

In some embodiments, the interface manifold **120** may comprise a porous, hydrophobic material. The hydrophobic characteristics of the interface manifold **120** may prevent the interface manifold **120** from directly absorbing fluid, such as exudate, from the tissue site **104**, but allow the fluid to pass through.

In some embodiments, the dressing **124** may include a base layer **132**, an adhesive **136**, a sealing member **140**, a fluid management assembly **144**, and a conduit interface **148**. Components of the dressing **124** may be added or removed to suit a particular application. In some embodiments, the dressing **124** may be adapted to provide reduced pressure from the reduced-pressure source **128** to the interface manifold **120**, and to extract fluid from the tissue site **104** through the interface manifold **120**.

Referring to FIGS. 1-4B, the base layer **132** may have a periphery **152** surrounding a central portion **156**, and a plurality of apertures **160** disposed through the periphery **152** and the central portion **156**. The base layer **132** may also have corners **158** and edges **159**. The corners **158** and the edges **159** may be part of the periphery **152**. One of the edges **159** may meet another of the edges **159** to define one of the corners **158**. Further, the base layer **132** may have a border **161** substantially surrounding the central portion **156** and positioned between the central portion **156** and the periphery **152**. In some embodiments, the border **161** may be free of the apertures **160**. In some embodiments, the base

## 12

layer **132** may be adapted to cover the interface manifold **120** and tissue surrounding the tissue site **104** such that the central portion **156** of the base layer **132** is positioned adjacent to or proximate to the interface manifold **120**, and the periphery **152** of the base layer **132** is positioned adjacent to or proximate to tissue surrounding the tissue site **104**. In such embodiments, the periphery **152** of the base layer **132** may surround the interface manifold **120**. Further, the apertures **160** in the base layer **132** may be in fluid communication with the interface manifold **120** and tissue surrounding the tissue site **104**.

The apertures **160** in the base layer **132** may have any shape, such as, for example, circles, squares, stars, ovals, polygons, slits, complex curves, rectilinear shapes, triangles, or other shapes. The apertures **160** may be formed by cutting, by application of local RF energy, or other suitable techniques for forming an opening. Each of the apertures **160** of the plurality of apertures **160** may be substantially circular in shape, having a diameter and an area. The area of the apertures **160** described in the illustrative embodiments herein may be substantially similar to the area in other embodiments for the apertures **160** that may have non-circular shapes. Further, the area of each of the apertures **160** may be substantially the same, or each of the areas may vary, for example, based on the position of the aperture **160** in the base layer **132**. For example, the area of the apertures **160** in the periphery **152** of the base layer **132** may be larger than the area of the apertures **160** in the central portion **156** of the base layer **132**. The apertures **160** may have a uniform pattern or may be randomly distributed on the base layer **132**. The size and configuration of the apertures **160** may be designed to control the adherence of the dressing **124** to the epidermis **106** as described below.

In some embodiments, the apertures **160** positioned in the periphery **152** may be apertures **160a**, the apertures **160** positioned at the corners **158** of the periphery **152** may be apertures **160b**, and the apertures **160** positioned in the central portion **156** may be apertures **160c**. In some embodiments, the apertures **160a** may have an area greater than the apertures **160b**. Further, in some embodiments, the apertures **160b** may have an area greater than the apertures **160c**. The dimensions of the base layer **132** may be increased or decreased, for example, substantially in proportion to one another to suit a particular application. Further, although the central portion **156**, the border **161**, and the periphery **152** of the base layer **132** are shown as having a substantially square shape, these and other components of the base layer **132** may have any shape to suit a particular application.

The base layer **132** may be a soft, pliable material suitable for providing a fluid seal with the tissue site **104** as described herein. For example, the base layer **132** may comprise a silicone gel, a soft silicone, hydrocolloid, hydrogel, polyurethane gel, polyolefin gel, hydrogenated styrenic copolymer gel, a foamed gel, a soft closed cell foam such as polyurethanes and polyolefins coated with an adhesive as described below, polyurethane, polyolefin, or hydrogenated styrenic copolymers. In some embodiments, the base layer **132** may include a silicone such as Scapa Soft-Pro®. The base layer **132** may have a thickness between about 500 microns (µm) and about 1000 microns (µm). In some embodiments, the base layer **132** may have a stiffness between about 5 Shore OO and about 80 Shore OO. Further, in some embodiments, the base layer **132** may be comprised of hydrophobic or hydrophilic materials.

In some embodiments (not shown), the base layer **132** may be a hydrophobic-coated material. For example, the base layer **132** may be formed by coating a spaced material,

such as, for example, woven, nonwoven, molded, or extruded mesh with a hydrophobic material. The hydrophobic material for the coating may be a soft silicone, for example. In this manner, the adhesive 136 may extend through openings in the spaced material analogous to the apertures 160.

In some embodiments, the adhesive 136 may be exposed to the apertures 160 in at least the periphery 152 of the base layer 132. Further, in some embodiments, the adhesive 136 may be positioned adjacent to, or positioned in fluid communication with, the apertures 160 in at least the periphery 152 of the base layer 132. Further, in some embodiments, the adhesive 136 may be exposed to or in fluid communication with tissue surrounding the tissue site 104 through the apertures 160 in the base layer 132. As described further below and shown in FIG. 3, the adhesive 136 may extend, deform, or be pressed through the plurality of apertures 160 to contact the epidermis 106 for securing the dressing 124 to, for example, tissue surrounding the tissue site 104. The apertures 160 may provide sufficient contact of the adhesive 136 to the epidermis 106 to secure the dressing 124 about the tissue site 104. However, the configuration of the apertures 160 and the adhesive 136, described below, may permit release and repositioning of the dressing 124 about the tissue site 104.

In some embodiments, the apertures 160b at the corners 158 of the periphery 152 may be smaller than the apertures 160a in other portions of the periphery 152. For a given geometry of the corners 158, the smaller size of the apertures 160b compared to the apertures 160a may enhance or increase the surface area of the adhesive 136 exposed to the apertures 160b and to tissue through the apertures 160b at the corners 158. The size and number of the apertures 160b in the corners 158 may be adjusted as necessary, depending on the chosen geometry of the corners 158, to enhance or increase the exposed surface area of the adhesive 136 as described above.

Similar to the apertures 160b in the corners 158, any of the apertures 160 may be adjusted in size and number to increase the surface area of the adhesive 136 exposed to or in fluid communication with the apertures 160 for a particular application or geometry of the base layer 132. For example, in some embodiments (not shown) the apertures 160b, or apertures of another size, may be positioned in the periphery 152 and at the border 161. Similarly, the apertures 160b, or apertures of another size, may be positioned as described above in other locations of the base layer 132 that may have a complex geometry or shape.

The adhesive 136 may be a medically-acceptable adhesive. In some embodiments, the adhesive 136 may be deformable or flowable. For example, the adhesive 136 may comprise an acrylic adhesive, rubber adhesive, high-tack silicone adhesive, polyurethane, or other adhesive substance. In some embodiments, the adhesive 136 may be a pressure-sensitive adhesive comprising an acrylic adhesive. The adhesive 136 may be a layer having substantially the same shape as the periphery 152 of the base layer 132. In some embodiments, the adhesive 136 may be continuous or discontinuous. Discontinuities in the adhesive 136 may be provided by apertures (not shown) in the adhesive 136. Apertures in the adhesive 136 may be formed after application of the adhesive 136 or by coating the adhesive 136 in patterns on a carrier layer, such as, for example, a side of the sealing member 140 adapted to face the epidermis 106. Further, apertures in the adhesive 136 may be sized to control the amount of the adhesive 136 extending through the apertures 160 in the base layer 132 to reach the epidermis

106. Apertures in the adhesive 136 may also be sized to enhance the Moisture Vapor Transfer Rate (MVTR) of the dressing 124, described further below.

Factors that may be utilized to control the adhesion strength of the dressing 124 may include the diameter, area, and number of the apertures 160 in the base layer 132, the thickness of the base layer 132, the thickness and amount of the adhesive 136, and the tackiness of the adhesive 136. An increase in the amount of the adhesive 136 extending through the apertures 160 may correspond to an increase in the adhesion strength of the dressing 124. A decrease in the thickness of the base layer 132 may correspond to an increase in the amount of adhesive 136 extending through the apertures 160. Thus, the diameter, area, and configuration of the apertures 160, the thickness of the base layer 132, and the amount and tackiness of the adhesive utilized may be varied to provide a desired adhesion strength for the dressing 124.

In some embodiments, the tackiness of the adhesive 136 may vary in different locations of the base layer 132. For example, in locations of the base layer 132 where the apertures 160 are comparatively large, such as the apertures 160a, the adhesive 136 may have a lower tackiness than other locations of the base layer 132 where the apertures 160 are smaller, such as the apertures 160b and 160c. In this manner, locations of the base layer 132 having larger apertures 160 and lower tackiness adhesive 136 may have an adhesion strength comparable to locations having smaller apertures 160 and higher tackiness adhesive 136.

A release liner 162 may be attached to or positioned adjacent to the base layer 132 to protect the adhesive 136 prior to application of the dressing 124 to the tissue site 104. Prior to application of the dressing 124 to the tissue site 104, the base layer 132 may be positioned between the sealing member 140 and the release liner 162. Removal of the release liner 162 may expose the base layer 132 and the adhesive 136 for application of the dressing 124 to the tissue site 104. The release liner 162 may also provide stiffness to assist with, for example, deployment of the dressing 124. The release liner 162 may be, for example, a casting paper, a film, or polyethylene. Further, the release liner 162 may be a polyester material such as polyethylene terephthalate (PET), or similar polar semi-crystalline polymer. The use of a polar semi-crystalline polymer for the release liner 162 may substantially preclude wrinkling or other deformation of the dressing 124. For example, the polar semi-crystalline polymer may be highly orientated and resistant to softening, swelling, or other deformation that may occur when brought into contact with components of the dressing 124, or when subjected to temperature or environmental variations, or sterilization. Further, a release agent may be disposed on a side of the release liner 162 that is configured to contact the base layer 132. For example, the release agent may be a silicone coating and may have a release factor suitable to facilitate removal of the release liner 162 by hand and without damaging or deforming the dressing 124. In some embodiments, the release agent may be fluorosilicone. In other embodiments, the release liner 162 may be uncoated or otherwise used without a release agent.

Continuing with FIGS. 1-4B, the sealing member 140 may also be referred to as a dressing sealing member 140. The sealing member 140 may have a periphery 164 and a central portion 168. The sealing member 140 may additionally include an aperture 170. The periphery 164 of the sealing member 140 may be positioned proximate to the periphery 152 of the base layer 132 such that the central portion 168 of the sealing member 140 and the central

portion 156 of the base layer 132 define an enclosure 172. The adhesive 136 may be positioned at least between the periphery 164 of the sealing member 140 and the periphery 152 of the base layer 132. The sealing member 140 may cover the tissue site 104 and the interface manifold 120 to provide a fluid seal and a sealed space 174 between the tissue site 104 and the sealing member 140 of the dressing 124. Further, the sealing member 140 may cover other tissue, such as a portion of the epidermis 106, surrounding the tissue site 104 to provide the fluid seal between the sealing member 140 and the tissue site 104. In some embodiments, a portion of the periphery 164 of the sealing member 140 may extend beyond the periphery 152 of the base layer 132 and into direct contact with tissue surrounding the tissue site 104. In other embodiments, the periphery 164 of the sealing member 140, for example, may be positioned in contact with tissue surrounding the tissue site 104 to provide the sealed space 174 without the base layer 132. Thus, the adhesive 136 may also be positioned at least between the periphery 164 of the sealing member 140 and tissue, such as the epidermis 106, surrounding the tissue site 104. The adhesive 136 may be disposed on a surface of the sealing member 140 adapted to face the tissue site 104 and the base layer 132.

The sealing member 140 may be formed from any material that allows for a fluid seal. A fluid seal may be a seal adequate to maintain reduced pressure at a desired site given the particular reduced pressure source or system involved. The sealing member 140 may comprise, for example, one or more of the following materials: hydrophilic polyurethane; cellulose; hydrophilic polyamides; polyvinyl alcohol; polyvinyl pyrrolidone; hydrophilic acrylics; hydrophilic silicone elastomers; an INSPIRE 2301 material from Expopack Advanced Coatings of Wrexham, United Kingdom having, for example, an MVTR (inverted cup technique) of 14400 g/m<sup>2</sup>/24 hours and a thickness of about 30 microns; a thin, uncoated polymer drape; natural rubbers; polyisoprene; styrene butadiene rubber; chloroprene rubber; polybutadiene; nitrile rubber; butyl rubber; ethylene propylene rubber; ethylene propylene diene monomer; chlorosulfonated polyethylene; polysulfide rubber; polyurethane (PU); EVA film; co-polyester; silicones; a silicone drape; a 3M Tegaderm® drape; a polyurethane (PU) drape such as one available from Avery Dennison Corporation of Pasadena, Calif.; a polyurethane (PU) film such as Scapa Bioflex 130 polyurethane Film®; polyether block polyamide copolymer (PEBAX), for example, from Arkema, France; Expopack 2327; or other appropriate material.

The sealing member 140 may be vapor permeable and liquid impermeable, thereby allowing vapor and inhibiting liquids from exiting the sealed space 174 provided by the dressing 124. In some embodiments, the sealing member 140 may be a flexible, breathable film, membrane, or sheet having a high MVTR of, for example, at least about 300 g/m<sup>2</sup> per 24 hours. In other embodiments, a low or no vapor transfer drape may be used. The sealing member 140 may comprise a range of medically suitable films having a thickness between about 15 microns (μm) to about 50 microns (μm).

The fluid management assembly 144 may be disposed in the enclosure 172. In some embodiments, the fluid management assembly 144 may include a first dressing wicking layer 176, a second dressing wicking layer 180, and an absorbent layer 184. The absorbent layer 184 may also be referred to as a dressing absorbent 184. The absorbent layer 184 may be positioned in fluid communication between the first dressing wicking layer 176 and the second dressing

wicking layer 180. The first dressing wicking layer 176 may have a grain structure adapted to wick fluid along a surface of the first dressing wicking layer 176. Similarly, the second dressing wicking layer 180 may have a grain structure adapted to wick fluid along a surface of the second dressing wicking layer 180. For example, the first dressing wicking layer 176 and the second dressing wicking layer 180 may wick or otherwise transport fluid in a lateral direction along the surfaces of the first dressing wicking layer 176 and the second dressing wicking layer 180, respectively. The surface of the first dressing wicking layer 176 may be normal relative to the thickness of the first dressing wicking layer 176, and the surface of the second dressing wicking layer 180 may be normal relative to the thickness of the second dressing wicking layer 180. The wicking of fluid along the first dressing wicking layer 176 and the second dressing wicking layer 180 may enhance the distribution of the fluid over a surface area of the absorbent layer 184, which may increase absorbent efficiency and resist fluid blockages. Fluid blockages may be caused by, for example, fluid pooling in a particular location in the absorbent layer 184 rather than being distributed more uniformly across the absorbent layer 184. The laminate combination of the first dressing wicking layer 176, the second dressing wicking layer 180, and the absorbent layer 184 may be adapted as described above to maintain an open structure, resistant to blockage, capable of maintaining fluid communication with, for example, the tissue site 104.

Referring to the embodiments of the fluid management assembly 144 depicted in FIGS. 1, 2, 5, and 6, a peripheral portion 186 of the first dressing wicking layer 176 may be coupled to a peripheral portion 187 of the second dressing wicking layer 180 to define a wicking layer enclosure 188 between the first dressing wicking layer 176 and the second dressing wicking layer 180. In some embodiments, the wicking layer enclosure 188 may surround or otherwise encapsulate the absorbent layer 184 between the first dressing wicking layer 176 and the second dressing wicking layer 180.

Referring to FIGS. 5 and 6, in some embodiments, the fluid management assembly 144 may include, without limitation, any number of wicking layers and absorbent layers as desired for treating a particular tissue site. For example, the absorbent layer 184 may be a plurality of absorbent layers 184 positioned in fluid communication between the first dressing wicking layer 176 and the second dressing wicking layer 180. Further, as shown in FIG. 6, in some embodiments, at least one intermediate wicking layer 189 may be disposed in fluid communication between the plurality of absorbent layers 184. Similar to the absorbent layer 184, the plurality of absorbent layers 184 and the at least one intermediate wicking layer 189 may be positioned within the wicking layer enclosure 188. In some embodiments, the absorbent layer 184 may be disposed between the sealing member 140 and the interface manifold 120, and the first dressing wicking layer 176 and the second dressing wicking layer 180 may be omitted.

Continuing with FIGS. 5 and 6, sides 184a of the absorbent layers 184 may remain in fluid communication with one another for enhancing efficiency. Similarly, sides 189a of the at least one intermediate wicking layer 189 shown in FIG. 6 may remain in fluid communication with one another and with the sides 184a of the absorbent layers 184. Further, including additional absorbent layers 184 may increase the absorbent mass of the fluid management assembly 144 and generally provide greater fluid capacity. However, for a given absorbent mass, multiple light coat-weight absorbent

layers **184** may be utilized rather than a single heavy coat-weight absorbent layer **184** to provide a greater absorbent surface area for further enhancing the absorbent efficiency.

In some embodiments, the absorbent layer **184** may be a hydrophilic material adapted to absorb fluid from, for example, the tissue site **104**. Materials suitable for the absorbent layer **184** may include, without limitation, super absorbent polymers and similar absorbent materials; Luquaflence® material; TEXSUS FP2326; BASF 402C; Technical Absorbents 2317, available from Technical Absorbents, Ltd. of Lincolnshire, United Kingdom; sodium polyacrylate super absorbers; cellulose (carboxy methyl cellulose and salts such as sodium CMC); Gelok® 30040-76 S/S/S 300 gsm absorbent; or alginates. Materials suitable for the first dressing wicking layer **176** and the second dressing wicking layer **180** may include, without limitation, any material having a grain structure capable of wicking fluid as described herein, such as, for example, LIBELTEX TDL2, 80 gsm, or similar materials, which may be non-woven.

The fluid management assembly **144** may be manufactured as a pre-laminated structure, or supplied as individual layers of material that can be stacked upon one another as described above. Individual layers of the fluid management assembly **144** may be bonded or otherwise secured to one another without adversely affecting fluid management by, for example, utilizing a solvent or non-solvent adhesive, or by thermal welding. Further, the fluid management assembly **144** may be coupled to the border **161** of the base layer **132** in any suitable manner, such as, for example, by a weld or an adhesive. The border **161**, being free of the apertures **160** as described above, may provide a flexible barrier between the fluid management assembly **144** and the tissue site **104** for enhancing comfort.

The dressing **124** may be modified in various embodiments to suit a particular application. In some embodiments, the absorbent layer **184** may be omitted from the fluid management assembly **144**, which may be beneficial, but not required, for communicating fluid exterior to or away from the dressing **124** and the tissue site **104** for offsite or remote storage. In such an embodiment, the first dressing wicking layer **176** and the second dressing wicking layer **180** may wick or draw fluid away from the tissue site **104** for transport to a location exterior to the dressing **124**. Further, the configuration of the first dressing wicking layer **176** and the second dressing wicking layer **180** described herein may preference fluid away from the tissue site **104** and prevent the fluid from returning to the tissue site **104** prior to removal of the fluid from the dressing **124**, for example, by the application of reduced pressure. The wicking layer enclosure **188** may enhance this ability to preference fluid away from the tissue site **104** and to prevent the fluid from returning to the tissue site **104**.

The dressing **124** may be further modified in various embodiments that may be suitable for some applications that communicate fluid from the tissue site **104** exterior to the dressing **124**. For example, in some embodiments, the first dressing wicking layer **176** or the second dressing wicking layer **180** may be omitted along with the absorbent layer **184** and the base layer **132**. In such an embodiment, the dressing **124** may comprise the sealing member **140** and one of the first dressing wicking layer **176** or the second dressing wicking layer **180** for disposing in the sealed space **174** between the sealing member **140** and the tissue site **104**. Further, in some embodiments, the fluid management assembly **144** may be omitted from the dressing **124**, and a dressing manifold (not shown) may be positioned in the

enclosure **172** in place of the fluid management assembly **144**. The dressing manifold may be configured as a layer and may be comprised of any material suitable for removing fluids from a tissue site through a plurality of pores, pathways, or flow channels as described herein, such as, without limitation, a foam, a woven material, a cast silicone, a polyurethane material, or any of the materials recited above for the interface manifold **120**. Further, in some embodiments, the dressing **124** may be modified by omitting the base layer **132** and replacing the fluid management assembly **144** with the above-described dressing manifold. In such an embodiment, the dressing **124** may comprise the sealing member **140** and the dressing manifold for disposing in the sealed space **174** between the sealing member **140** and the tissue site **104**. Further, in some embodiments, the absorbent layer **184** may be omitted and replaced with the dressing manifold such that the dressing manifold is positioned between the first dressing wicking layer **176** and the second dressing wicking layer **180**.

Referring to FIGS. **1** and **2**, in some embodiments, the enclosure **172** defined by the base layer **132** and the sealing member **140** may include an optional anti-microbial layer **190**. The addition of the anti-microbial layer **190** may reduce the probability of excessive bacterial growth within the dressing **124** to permit the dressing **124** to remain in place for an extended period. The anti-microbial layer **190** may be, for example, an additional layer included as a part of the fluid management assembly **144**, or a coating of an anti-microbial agent disposed in any suitable location within the dressing **124**. The anti-microbial layer **190** may be comprised of elemental silver or a similar compound, for example. In some embodiments, the anti-microbial agent may be formulated in any suitable manner and associated with other components of the dressing **124**.

Referring to FIGS. **1**, **2**, and **7**, the conduit interface **148** may be positioned proximate to the sealing member **140** and in fluid communication with the enclosure **172** of the dressing **124**. For example, the conduit interface **148** may be in fluid communication with the dressing **124** through the aperture **170** in the sealing member **140**. The conduit interface **148** may provide reduced pressure from the reduced-pressure source **128** to the dressing **124**. The conduit interface **148** may also be adapted to be positioned in fluid communication with the optional interface manifold **120**. An optional liquid trap **192** may be positioned in fluid communication between the dressing **124** and the reduced-pressure source **128**. The liquid trap **192** may be any suitable containment device having a sealed internal volume capable of retaining liquid, such as condensate or other liquids.

The conduit interface **148** may comprise a medical-grade, soft polymer or other pliable material. As non-limiting examples, the conduit interface **148** may be formed from polyurethane, polyethylene, polyvinyl chloride (PVC), fluorosilicone, or ethylene-propylene. In some illustrative, non-limiting embodiments, conduit interface **148** may be molded from DEHP-free PVC. The conduit interface **148** may be formed in any suitable manner such as by molding, casting, machining, or extruding. Further, the conduit interface **148** may be formed as an integral unit or as individual components and may be coupled to the dressing **124** by, for example, adhesive or welding.

In some embodiments, the conduit interface **148** may be formed of an absorbent material having absorbent and evaporative properties. The absorbent material may be vapor permeable and liquid impermeable, thereby being configured to permit vapor to be absorbed into and evaporated from the material through permeation while inhibiting per-

meation of liquids. The absorbent material may be, for example, a hydrophilic polymer such as a hydrophilic polyurethane. Although the term hydrophilic polymer may be used in the illustrative embodiments that follow, any absorbent material having the properties described herein may be suitable for use in the system 102. Further, the absorbent material or hydrophilic polymer may be suitable for use in various components of the system 102 as described herein.

The use of such a hydrophilic polymer for the conduit interface 148 may permit liquids in the conduit interface 148 to evaporate, or otherwise dissipate, during operation. For example, the hydrophilic polymer may allow the liquid to permeate or pass through the conduit interface 148 as vapor, in a gaseous phase, and evaporate into the atmosphere external to the conduit interface 148. Such liquids may be, for example, condensate or other liquids. Condensate may form, for example, as a result of a decrease in temperature within the conduit interface 148, or other components of the system 102, relative to the temperature at the tissue site 104. Removal or dissipation of liquids from the conduit interface 148 may increase visual appeal and prevent odor. Further, such removal of liquids may also increase efficiency and reliability by reducing blockages and other interference with the components of the system 102.

Similar to the conduit interface 148, the liquid trap 192, and other components of the system 102, may also be formed of an absorbent material or a hydrophilic polymer. The absorptive and evaporative properties of the hydrophilic polymer may also facilitate removal and dissipation of liquids residing in the liquid trap 192, and other components of the system 102, by evaporation. Such evaporation may leave behind a substantially solid or gel-like waste. The substantially solid or gel-like waste may be cheaper to dispose than liquids, providing a cost savings for operation of the system 102. The hydrophilic polymer may be used for other components in the system 102 where the management of liquids is beneficial.

In some embodiments, the absorbent material or hydrophilic polymer may have an absorbent capacity in a saturated state that is substantially equivalent to the mass of the hydrophilic polymer in an unsaturated state. The hydrophilic polymer may be fully saturated with vapor in the saturated state and substantially free of vapor in the unsaturated state. In both the saturated state and the unsaturated state, the hydrophilic polymer may retain substantially the same physical, mechanical, and structural properties. For example, the hydrophilic polymer may have a hardness in the unsaturated state that is substantially the same as a hardness of the hydrophilic polymer in the saturated state. The hydrophilic polymer and the components of the system 102 incorporating the hydrophilic polymer may also have a size that is substantially the same in both the unsaturated state and the saturated state. Further, the hydrophilic polymer may remain dry, cool to the touch, and pneumatically sealed in the saturated state and the unsaturated state. The hydrophilic polymer may also remain substantially the same color in the saturated state and the unsaturated state. In this manner, this hydrophilic polymer may retain sufficient strength and other physical properties to remain suitable for use in the system 102. An example of such a hydrophilic polymer is offered under the trade name Techophilic HP-93A-100, available from The Lubrizol Corporation of Wickliffe, Ohio, United States. Techophilic HP-93A-100 is an absorbent hydrophilic thermoplastic polyurethane capable of absorbing 100% of the unsaturated mass of the polyurethane in water and having a durometer or Shore Hardness of about 83 Shore A.

The conduit interface 148 may carry an odor filter 194 adapted to substantially preclude the passage of odors from the tissue site 104 out of the sealed space 174. Further, the conduit interface 148 may carry a primary hydrophobic filter 195 adapted to substantially preclude the passage of liquids through the primary hydrophobic filter 195. The odor filter 194 and the primary hydrophobic filter 195 may be disposed in the conduit interface 148 or other suitable location such that fluid communication between the reduced-pressure source 128, or optional therapy unit 130, and the dressing 124 is provided through the odor filter 194 and the primary hydrophobic filter 195. In some embodiments, the odor filter 194 and the primary hydrophobic filter 195 may be secured within the conduit interface 148 in any suitable manner, such as by adhesive or welding. In other embodiments, the odor filter 194 or the primary hydrophobic filter 195 may be omitted, or positioned proximate to any exit location in the system 102 or the dressing 124 that is in fluid communication with the atmosphere, the reduced-pressure source 128, or the optional therapy unit 130.

The odor filter 194 may be comprised of a carbon material in the form of a layer or particulate. For example, the odor filter 194 may comprise a woven carbon cloth filter such as those manufactured by Chemviron Carbon, Ltd. of Lancashire, United Kingdom. The primary hydrophobic filter 195 may be comprised of a material that is liquid impermeable and vapor permeable. For example, the primary hydrophobic filter 195 may comprise a material manufactured under the designation MMT-314 by W.L. Gore & Associates, Inc. of Newark, Del., United States, or similar materials. The primary hydrophobic filter 195 may be provided in the form of a membrane or layer.

Continuing with FIGS. 1, 2, and 7, the reduced-pressure source 128 may provide reduced pressure to the dressing 124 and the sealed space 174. The reduced-pressure source 128 may be any suitable device for providing reduced pressure, such as, for example, a vacuum pump, wall suction, hand pump, manual pump, or other source. In some embodiments, the reduced-pressure source 128 may be a component of the therapy unit 130. The therapy unit 130 may include control circuitry and sensors, such as a pressure sensor, that may be configured to monitor reduced pressure at the tissue site 104. The therapy unit 130 may also be configured to control the amount of reduced pressure from the reduced-pressure source 128 being applied to the tissue site 104 according to a user input and a reduced-pressure feedback signal received from the tissue site 104. In some embodiments, the reduced pressure source 128 (such as a manual pump, hand pump, or the like) may comprise a container or may be fluidly connected to a container that receives fluid collected from the tissue site 104. Thus, when the reduced pressure source 128 generates reduced pressure, fluid may be communicated from the tissue site, through the dressing, through the bridge, and received and stored in the container of the reduced pressure source 128 or fluidly connected to the reduced pressure source 128.

As used herein, "reduced pressure" may refer to a pressure less than the ambient pressure at a tissue site being subjected to treatment. In some embodiments, the reduced pressure may be less than the atmospheric pressure. Further, in some embodiments, the reduced pressure may also be less than a hydrostatic pressure at a tissue site. Unless otherwise indicated, values of pressure stated herein are gauge pressures. While the amount and nature of reduced pressure applied to a tissue site may vary according to the application, in some embodiments, the reduced pressure may be between

–5 mm Hg and –500 mm Hg. In some embodiments, the reduced pressure may be between –100 mm Hg and –200 mm Hg.

The reduced pressure delivered may be, for example, constant, varied, patterned, or random. Further, the reduced pressure may be delivered continuously or intermittently. Although the terms “vacuum” and “negative pressure” may be used to describe the pressure applied to a tissue site, the actual pressure applied to the tissue site may be more than the pressure normally associated with a complete vacuum. Consistent with the use herein, an increase in reduced pressure or vacuum pressure may refer to a relative reduction in absolute pressure. Further, an increase in reduced pressure may correspond to a reduction in pressure (more negative relative to ambient pressure), and a decrease in reduced pressure may correspond to an increase in pressure (less negative relative to ambient pressure).

Referring to FIGS. 1 and 7, a conduit 196 having an internal lumen 197 may be coupled in fluid communication between the reduced-pressure source 128 and the dressing 124. The internal lumen 197 may have an internal diameter between about 0.5 millimeters to about 3.0 millimeters. In some embodiments, the internal diameter of the internal lumen 197 may be between about 1 millimeter to about 2 millimeters. The conduit interface 148 may be coupled in fluid communication with the dressing 124 and adapted to connect between the conduit 196 and the dressing 124 for providing fluid communication with the reduced-pressure source 128. The conduit interface 148 may be fluidly coupled to the conduit 196 in any suitable manner, such as, for example, by an adhesive, solvent or non-solvent bonding, welding, or interference fit. The aperture 170 in the sealing member 140 may provide fluid communication between the dressing 124 and the conduit interface 148. For example, the conduit interface 148 may be in fluid communication with the enclosure 172 or the sealed space 174 through the aperture 170 in the sealing member 140. In some embodiments, the conduit 196 may be inserted into the dressing 124 through the aperture 170 in the sealing member 140 to provide fluid communication with the reduced-pressure source 128 without use of the conduit interface 148. The reduced-pressure source 128 may also be directly coupled in fluid communication with the dressing 124 or the sealing member 140 without use of the conduit 196. In some embodiments, the conduit 196 may be, for example, a flexible polymer tube. A distal end of the conduit 196 may include a coupling 198 for attachment to the reduced-pressure source 128.

The conduit 196 may have a secondary hydrophobic filter 199 disposed in the internal lumen 197 such that fluid communication between the reduced-pressure source 128 and the dressing 124 is provided through the secondary hydrophobic filter 199. The secondary hydrophobic filter 199 may be, for example, a porous, sintered polymer cylinder sized to fit the dimensions of the internal lumen 197 to substantially preclude liquid from bypassing the cylinder. The secondary hydrophobic filter 199 may also be treated with an absorbent material adapted to swell when brought into contact with liquid to block the flow of the liquid. The secondary hydrophobic filter 199 may be positioned at any location within the internal lumen 197. However, positioning the secondary hydrophobic filter 199 within the internal lumen 197 closer toward the reduced-pressure source 128, rather than the dressing 124, may allow a user to detect the presence of liquid in the internal lumen 197.

In some embodiments, the conduit 196 and the coupling 198 may be formed of an absorbent material or a hydrophilic

polymer as described above for the conduit interface 148. In this manner, the conduit 196 and the coupling 198 may permit liquids in the conduit 196 and the coupling 198 to evaporate, or otherwise dissipate, as described above for the conduit interface 148. The conduit 196 and the coupling 198 may be, for example, molded from the hydrophilic polymer separately, as individual components, or together as an integral component. Further, a wall of the conduit 196 defining the internal lumen 197 may be extruded from the hydrophilic polymer. The conduit 196 may be less than about 1 meter in length, but may have any length to suit a particular application.

Referring to FIG. 8, another embodiment of a fluid management assembly 244 suitable for use with the dressing 124 and the system 102 is shown. The fluid management assembly 244 may include a first dressing wicking layer 276, a second dressing wicking layer 280, and an absorbent layer 284 comprised of substantially the same materials and properties as those described above in connection with the fluid management assembly 144. Thus, the first dressing wicking layer 276, the second dressing wicking layer 280, and the absorbent layer 284 may be analogous to the first dressing wicking layer 176, the second dressing wicking layer 180, and the absorbent layer 184, respectively.

In the fluid management assembly 244, the second dressing wicking layer 280 may have a peripheral portion 287. The second dressing wicking layer 280 and the peripheral portion 287 of the second dressing wicking layer 280 may be positioned in contact with the sealing member 140. The absorbent layer 284 may have a peripheral portion 285 extending beyond the peripheral portion 287 of the second dressing wicking layer 280. The absorbent layer 284 may be positioned adjacent to or proximate to the second dressing wicking layer 280 such that the peripheral portion 285 of the absorbent layer 284 is in contact with the sealing member 140 surrounding the peripheral portion 287 of the second dressing wicking layer 280. Similarly, the first dressing wicking layer 276 may have a peripheral portion 286 extending beyond the peripheral portion 285 of the absorbent layer 284. The first dressing wicking layer 276 may be positioned adjacent to or proximate to the absorbent layer 284 such that the peripheral portion 286 of the first dressing wicking layer 276 is in contact with the sealing member 140 surrounding the peripheral portion 285 of the absorbent layer 284. Further, the first dressing wicking layer 276 may be positioned adjacent to or proximate to the base layer 132. Thus, at least the peripheral portion 287, the peripheral portion 285, and the peripheral portion 286 may be coupled to the sealing member 140, such as, for example, by an adhesive coating disposed on a surface of the sealing member 140 facing the base layer 132. The adhesive coating may be analogous to the adhesive 136 that may be applied across the surface of the sealing member 140 facing the base layer 132. The second dressing wicking layer 280, the absorbent layer 284, and the first dressing wicking layer 276 may respectively have increasing surface areas to enhance contact with the adhesive coating described above. In other embodiments, the fluid management assembly 244 may include any number of absorbent layers and wicking layers for treating a particular tissue site.

In operation, according to some illustrative embodiments, the interface manifold 120 may be disposed against or proximate to the tissue site 104. The dressing 124 may be applied over or covering the interface manifold 120 and the tissue site 104 to form the sealed space 174. For example, the base layer 132 may be applied covering the interface manifold 120 and tissue surrounding the tissue site 104. The

materials described above for the base layer 132 may have a tackiness that may hold the dressing 124 initially in position. The tackiness may be such that if an adjustment is desired, the dressing 124 may be removed and reapplied. Once the dressing 124 is in the desired position, a force may be applied, such as hand pressure, on a side of the sealing member 140 facing outward or opposite the tissue site 104. The force applied to the sealing member 140 may cause at least some portion of the adhesive 136 to penetrate or extend through the plurality of apertures 160 and into contact with tissue surrounding the tissue site 104, such as the epidermis 106, to releasably adhere the dressing 124 about the tissue site 104. In this manner, the configuration of the dressing 124 described above may provide an effective and reliable seal against challenging anatomical surfaces, such as an elbow or heal, at and around the tissue site 104. Further, the dressing 124 may permit re-application or re-positioning to, for example, correct air leaks caused by creases and other discontinuities in the dressing 124 and the tissue site 104. The ability to rectify leaks may increase the reliability of the therapy and reduce power consumption.

As the dressing 124 comes into contact with fluid from the tissue site 104, the fluid may move through the apertures 160 toward the fluid management assembly 144, 244. The fluid management assembly 144, 244 may wick or otherwise move the fluid away from the tissue site 104, and through the interface manifold 120, if equipped. As described above, the interface manifold 120 may be adapted to communicate fluid from the tissue site 104 rather than store the fluid. Thus, the fluid management assembly 144, 244 may be adapted to wick, pull, draw, or otherwise attract fluid from the tissue site 104 through the interface manifold 120. In the fluid management assembly 144, 244, the fluid may initially come into contact with the first dressing wicking layer 176, 276. The first dressing wicking layer 176, 276 may distribute the fluid laterally along the surface of the first dressing wicking layer 176, 276 for absorption or removal from the dressing 124. Similarly, fluid may come into contact with the second dressing wicking layer 180, 280 and may be distributed laterally along the surface of the second dressing wicking layer 180, 280 for absorption or removal from the dressing 124.

Referring to FIGS. 9-11, in some embodiments, a bridge assembly 310 may extend away from the tissue site 104 and the dressing 124 to define a fluid passageway between the tissue site 104 and the reduced-pressure source 128. For example, the bridge assembly 310 may be coupled in fluid communication between the dressing 124 and the reduced-pressure source 128. However, other applications for the bridge assembly 310 are possible. In some embodiments, the bridge assembly 310 may include a storage bridge 320, a sealing apparatus 330, and the conduit interface 148. It should be understood, that while dressing 124 is described with reference to FIGS. 9-11, dressings 324 or dressings 424, discussed herein, may additionally or alternatively be used with reference to FIGS. 9-11.

The storage bridge 320 may include a receiving end 334 separated or spaced apart from a transmitting end 338 by a length 340. The receiving end 334 may have a receiving end aperture 342, and the transmitting end 338 may have a transmitting end aperture 346. The receiving end 334 and the receiving end aperture 342 may be in fluid communication with the transmitting end 338 and the transmitting end aperture 346 through the length 340 of the storage bridge 320.

The conduit interface 148 may be adapted to be fluidly coupled to the receiving end 334 of the storage bridge 320

through, for example, the receiving end aperture 342. Thus, the conduit interface 148 may be in fluid communication with the transmitting end 338 through the length 340 of the storage bridge 320. The sealing apparatus 330 may be positioned about the transmitting end aperture 346 and between the transmitting end 338 and the dressing 124 for coupling the transmitting end 338 to the dressing 124 and in fluid communication with the dressing 124 through the transmitting end aperture 346. Thus, the conduit interface 148 may be positioned in fluid communication with the dressing 124 through the storage bridge 320. The sealing apparatus 330 may be any suitable device for making the connections described above, such as, without limitation, an adhesive ring or weld.

In some embodiments, the storage bridge 320 may include a bridge envelope 350, a bridge absorbent 354, and a bridge sealing member 358. The bridge envelope 350 may extend along the length 340 of the storage bridge 320. Further, the bridge envelope 350 may define an internal volume 360. The bridge absorbent 354 may be disposed within the internal volume 360 of the bridge envelope 350. In some embodiments, the bridge absorbent 354 may have a volume 362, in an unsaturated state, which is less than the internal volume 360 of the bridge envelope 350. In some embodiments, the bridge absorbent 354 may have a volume 362, in an unsaturated state, which is at least 5 percent less than the internal volume 360 of the bridge envelope 350. In some embodiments, the bridge absorbent 354 may have a volume 362, in an unsaturated state, which is at least 10 percent less than the internal volume 360 of the bridge envelope 350. In some embodiments, the bridge absorbent 354 may have a volume 362, in an unsaturated state, which is between 20 percent to about 90 percent of the internal volume 360 of the bridge envelope 350. In some embodiments, a cross-sectional area 364 of the bridge absorbent 354 may be less than a cross-sectional area 366 of the bridge envelope 350. The bridge absorbent 354 having a volume 362 or cross-sectional area 364 less than the internal volume 360 or cross-sectional area 366 of the bridge envelope 350 may allow for free movement of fluids and distribution of pressure around the bridge absorbent 354 when positioned within the internal volume 360 of the bridge envelope 350. In some embodiments, the bridge envelope 350 may entirely surround the bridge absorbent 354. Further, in some embodiments, the bridge envelope 350 may encapsulate the bridge absorbent 354. Further, in some embodiments, the bridge absorbent 354 may be moveable, expandable, or swellable within the internal volume 360 of the bridge envelope 350. For example, the bridge absorbent 354 may be configured to move, expand, or swell when the bridge absorbent 354 becomes fully or partially saturated with a liquid.

Further, the bridge envelope 350 may include an internal surface 368 and the bridge absorbent 354 may include an external surface 370. In some embodiments, at least a portion of the external surface 370 of the bridge absorbent 354 may be spaced apart or separated from the internal surface 368 of the bridge envelope 350. Further, in some embodiments, the entire external surface 370 of the bridge absorbent 354 may be separated or spaced apart from the internal surface 368 of the bridge envelope 350. Such a separation or space between the external surface 370 of the bridge absorbent 354 and the internal surface 368 of the bridge envelope 350 may occur, for example, as a result of fluids positioned between the external surface 370 and the internal surface 368 during operation.

In some embodiments, the bridge envelope 350 may include a fluid acquisition surface 372 and a fluid distribu-



tion surface **374**. The fluid distribution surface **374** may be positioned opposite the fluid acquisition surface **372**. The fluid distribution surface **374** may face the internal volume **360** of the bridge envelope **350** and the bridge absorbent **354**. In some embodiments, at least a portion of the bridge absorbent **354** may be spaced apart from the fluid distribution surface **374** of the bridge envelope **350**. In some embodiments, the fluid distribution surface **374** may include a plurality of longitudinal fibers **391** oriented substantially in a longitudinal direction along the length **340** of the storage bridge **320**. Further, in some embodiments, the fluid acquisition surface **372** may include a plurality of vertical fibers **393** oriented substantially normal relative to the longitudinal fibers **391**.

In some embodiments, the bridge envelope **350** may include a first bridge wicking layer **380** and a second bridge wicking layer **382**. The first bridge wicking layer **380** and the second bridge wicking layer **382** may each extend along the length **340** of the storage bridge **320**, and may be disposed within an internal passageway **384** that may be defined by the bridge sealing member **358**. A periphery or edge of the first bridge wicking layer **380** may be coupled to a periphery or edge of the second bridge wicking layer **382** in any suitable manner, such as, for example, by a weld **386**, to define the internal volume **360** of the bridge envelope **350**. The bridge absorbent **354** may be positioned between the first bridge wicking layer **380** and the second bridge wicking layer **382**. The first bridge wicking layer **380** and the second bridge wicking layer **382** may each include the fluid acquisition surface **372** and the fluid distribution surface **374**. The fluid distribution surface **374** may be positioned on an opposite side of the first bridge wicking layer **380** and the second bridge wicking layer **382** from the fluid acquisition surface **372**. Further, the fluid distribution surface **374** of the first bridge wicking layer **380** and the second bridge wicking layer **382** may face the bridge absorbent **354**. In some embodiments, at least a portion of the bridge absorbent **354** may be spaced apart or separated from the fluid distribution surface **374** of the first bridge wicking layer **380** and the second bridge wicking layer **382**.

In some embodiments, the bridge envelope **350** may comprise a non-woven material or structure such as, without limitation, a polyester, co-polyester, polyolefin, cellulosic fiber, and combinations or blends of the foregoing materials. In some embodiments, the bridge envelope **350** may comprise LIBELTEX TDL4 or LIBELTEX TDL2, or any of the materials recited above for the first dressing wicking layer **176** and the second dressing wicking layer **180**. Further, in some embodiments, the bridge envelope **350** may comprise laminations with fiber or foam structures. The first bridge wicking layer **380** and the second bridge wicking layer **382** may each be comprised of the same materials recited above for the bridge envelope **350**. In some embodiments, the bridge absorbent **354** may include a super-absorbent polymer or similar absorbent material, such as, without limitation, TEXSUS FP2325, or Gelok® 30040-76 S/S/S 300 gsm absorbent. Further, in some embodiments, the bridge absorbent **354** may comprise any of the materials recited above for the dressing absorbent **184**.

The bridge sealing member **358** may encapsulate the bridge envelope **350**, and may define the internal passageway **384**. The internal passageway **384** may be in fluid communication between the receiving end **334** and the transmitting end **338** of the storage bridge **320**. In some embodiments, the bridge sealing member **358** may entirely surround the bridge envelope **350**. In some embodiments, the bridge envelope **350** may be disposed within the internal

passageway **384** defined by the bridge sealing member **358**. In some embodiments, the bridge sealing member **358** may sealingly enclose the bridge envelope **350** between the receiving end **334** and the transmitting end **338** of the storage bridge **320**.

The bridge sealing member **358** may be comprised of similar materials described above for the dressing sealing member **140**. For example, in some embodiments, the bridge sealing member **358** may comprise a substantially liquid impermeable film. Further, in some embodiments, the bridge sealing member **358** may comprise a vapor permeable film. Further, in some embodiments, the bridge sealing member **358** may comprise a breathable film. Additional examples of materials suitable for the bridge sealing member **358** may include, without limitation, a polyurethane drape or film such as Scapa Bioflex 130 polyurethane Film®; films formed from polymers, such as polyester and co-polyester; polyamide; polyamide/block polyether; acrylics; vinyl esters; polyvinyl alcohol copolymers; films with and without adhesive; and high Moisture Vapor Transfer Rate (MVTR) films, such as, for example, an INSPIRE 2305 polyurethane drape. High MVTR films may provide for evaporation of condensate, which may occur around the entire exterior surface of the storage bridge **320**. In this manner, capacity, fluid handling, and evaporative properties of the storage bridge **320** may be enhanced or improved due at least to increased surface area and air movement provided around all sides and portions of the exterior surface of the storage bridge **320**.

In some embodiments, the bridge sealing member **358** may include a first sealing layer **388** and a second sealing layer **390**. A first periphery or edge of the first sealing layer **388** may be coupled to a second periphery or edge of the second sealing layer **390** around the bridge envelope **350** in any suitable manner, such as, for example, by a weld **392** for forming the bridge sealing member **358** and encapsulating the bridge envelope **350** therein. In other embodiments, the bridge sealing member **358** may be formed from a single layer of material.

The bridge assembly **310** may include features to indicate a level of fluid retained in the storage bridge **320**. For example, the storage bridge **320** may include a fluid capacity indicator **394** or a plurality of fluid capacity indicators **394** positioned along the length **340** of the storage bridge **320**. In some embodiments, the fluid capacity indicators **394** may be positioned sequentially along the length **340** of the storage bridge **320** to indicate an amount of fluid present or fluid capacity remaining in the storage bridge **320**. The fluid capacity indicators **394** may each identify a fraction or percentage of the total fluid capacity of the storage bridge **320**. Further, in some embodiments, a liquid changing dye (not shown) may be positioned within the internal passageway **384** defined by the bridge sealing member **358** in any suitable manner, such as, for example, as a coating, layer, or particulate. The liquid changing dye may also indicate a level of fluid retained in the storage bridge **320**. Materials suitable for use as the liquid changing dye may include, without limitation, water soluble or swellable polymers, such as polyvinyl alcohol and copolymers; acrylics; polyurethanes; and soluble salts, such as sodium, potassium, and sodium acrylate. Water soluble dyes, such as, for example, indigo carmine or fast green FCF, may be mixed into the water soluble polymers set forth above. Such a compound may swell or dissolve when exposed to fluid, which may release the dye, indicating the fluid level in the storage bridge **320**.

In operation, the reduced-pressure source **128** may be fluidly coupled to the receiving end **334** of the storage bridge **320**. For example, the conduit interface **148** may be fluidly coupled to the receiving end **334**, and the conduit **196** may be fluidly coupled between the conduit interface **148** and the reduced-pressure source **128** analogous to the previously described embodiments. The transmitting end **338** of the storage bridge **320** may be fluidly coupled to the dressing **124** as described above. The reduced-pressure source **128** may be activated to provide reduced pressure to the dressing **124** through the storage bridge **320**, which may draw, wick, or pull fluids from the tissue site **104** and the dressing **124** into the storage bridge **320**.

The structure of the storage bridge **320** may be configured to be more hydrophilic or absorbent than the dressing **124**. For example, in some previously described embodiments, the dressing **124** may be configured without an absorbent while the storage bridge **320** is configured with the bridge absorbent **354**. In other embodiments, the dressing **124** may include components that possess some absorbency, but less absorbency than the storage bridge **320**. Accordingly, the system **102** may be configured with an absorbent gradient that increases in absorbency or hydrophilicity with increasing distance away from the tissue site **104**, such as, for example, from the dressing **124** toward the reduced-pressure source **128**. Therefore, fluids may be drawn from the tissue site **104** into the storage bridge **320** by the application of the reduced pressure and by operation of attractive forces that may be exerted on the fluid by the absorbent gradient.

As fluid enters the storage bridge **320**, the fluid may first contact portions of the bridge absorbent **354** near the transmitting end **338** of the storage bridge **320**, which may become saturated with the fluid or blocked. Such fluid saturation or blockage near the transmitting end **338** of the storage bridge **320** may force the fluid to move along the length **340** of the storage bridge **320**, between the external surface **370** of the storage bridge **320** and the internal surface **368** of the bridge envelope **350**, toward the receiving end **334** of the storage bridge **320** for absorption. The internal surface **368** of the bridge envelope **350** may also be the fluid distribution surface **374** of the bridge envelope **350**, which may enhance the movement and distribution of the fluid within the internal volume **360** of the bridge envelope **350** and the bridge absorbent **354**. The fluid may also wick or travel along the fluid acquisition surface **372** along the length **340** of the storage bridge **320** and pass through or permeate the bridge envelope **350** to the fluid distribution surface **374** for distribution to the bridge absorbent **354**. The fluid may continue to travel in this manner along the length **340** of the storage bridge **320** from the transmitting end **338** to the receiving end **334** until the storage bridge **320** reaches full fluid capacity. Portions of the storage bridge **320** that become saturated or blocked with fluid may swell and serve as an indication of the level of fluid contained in the storage bridge **320**. The fluid capacity indicator **394** and the liquid changing dye may also provide an indication of fluid capacity as described above.

Referring to FIG. **12**, a graphical plot of pressure in the dressing **124** versus fluid volume is shown as a result of performance testing. In the testing, the storage bridge **320** was assembled with the dressing **124** according to this disclosure. The storage bridge **320** was held in a vertical position, and a reduced pressure of 125 mmHg was applied to the dressing **124** through the storage bridge **320**. Pressure measurements were taken in the dressing **124** at an edge **Y** and a center **X** of the dressing **124**, shown in FIG. **9**, during delivery of saline fluid to the dressing **124** at a rate of 0.83

cc per hour. As shown in FIG. **12**, the measured pressure remained stable between about 115 mmHg to about 125 mmHg, illustrating that no significant drop in reduced pressure occurred in the system **102** or through the storage bridge **320** during the addition of the saline in the testing.

Among other benefits described above, the storage bridge **320** may reduce power consumption, leakage, and other challenges that may be associated with fluid head pressure caused by a static column of fluid that can reside in a conventional tube or similar structure providing fluid communication between a dressing and a reduced-pressure source. Further, a mass of fluid removed from a tissue site may be moved away from the surface of the tissue site. The storage bridge **320** may also provide a low-profile and conformable solution for providing fluid communication with a tissue site, which may enhance patient comfort.

Referring to the drawings, FIG. **13** depicts an illustrative embodiment of a system **302** for treating a tissue site **104** of a patient. The tissue site **104** may extend through or otherwise involve an epidermis **106**, a dermis **108**, and a subcutaneous tissue **110**. The tissue site **104** may be a sub-surface tissue site as depicted in FIG. **13** that may extend below the surface of the epidermis **106**. Further, the tissue site **104** may be a surface tissue site (not shown) that may predominantly reside on the surface of the epidermis **106**, such as, for example, an incision. The system **302** may provide therapy to, for example, the epidermis **106**, the dermis **108**, and the subcutaneous tissue **110**, regardless of the positioning of the system **302** or the type of tissue site. The system **302** may be used to treat wound and shallow wounds on a patient such as venous leg ulcers (VLUs). The system may also be attached to a patient over or near a wound and compressed against tissue at or near the wound using bandages and/or compression garments (such as a compression garment with a hydrophobic coating). A compression garment (such as a compression garment with a hydrophobic coating) may prevent evaporated fluid from pooling in the dressing of the system **302**, reduce the likelihood of infection, and the negative impact on patient wellbeing as a result of odor. In some embodiments, a compression garment may include an activated charcoal component to mitigate odor. The activated charcoal component may increase evaporation rates from the dressing of the system **302** as fluid molecules will be drawn to the coated compression garment. The system **302** under compression against tissue may provide a low profile on a patient. The system **302** may also be used without limitation at other tissue sites.

The tissue site **104** may be the bodily tissue of any human, animal, or other organism, including bone tissue, adipose tissue, muscle tissue, dermal tissue, vascular tissue, connective tissue, cartilage, tendons, ligaments, or any other tissue. Treatment of the tissue site **104** may include the removal of fluids, such as exudate or ascites.

Continuing with FIG. **13**, the system **302** may include an optional tissue interface, such as an interface manifold **120**. Further, the system **302** may include a dressing **324** and a reduced-pressure source **128**. The reduced-pressure source **128** may be a component of an optional therapy unit **130**. In some embodiments, the reduced-pressure source **128** and the therapy unit **130** may be separate components. Further, in some embodiments, the interface manifold **120** may be omitted for different types of tissue sites or different types of therapy, such as, for example, epithelialization. If equipped, the interface manifold **120** may be adapted to be positioned proximate to or adjacent to the tissue site **104**, such as, for example, by cutting or otherwise shaping the interface manifold **120** in any suitable manner to fit the tissue site **104**.

As described below, the interface manifold **120** may be adapted to be positioned in fluid communication with the tissue site **104** to distribute reduced pressure to the tissue site **104**. In some embodiments, the interface manifold **120** may be positioned in direct contact with the tissue site **104**.

The tissue interface or the interface manifold **120** may be formed from any manifold material or flexible bolster material that provides a vacuum space, or treatment space, such as, for example, a porous and permeable foam or foam-like material, a member formed with pathways, a graft, a non-adherent material, a non-adherent copolymer mesh, or a gauze. In some embodiments, the interface manifold **120** may be a reticulated, open-cell polyurethane or polyether foam that may be fluid permeable while under a reduced pressure. One such foam material is VAC® GranuFoam® material available from Kinetic Concepts, Inc. (KCI) of San Antonio, Tex. Further, in some embodiments, any material or combination of materials may be used as a manifold material for the interface manifold **120** provided that the manifold material is operable to distribute or collect fluid. For example, herein the term manifold may refer to a substance or structure configured for delivering fluids to or removing fluids from a tissue site through a plurality of pores, pathways, or flow channels. The plurality of pores, pathways, or flow channels may be interconnected to improve the distribution of fluids provided to and removed from an area around the manifold. Examples of manifolds may include, without limitation, devices that have structural elements arranged to form flow channels, cellular foam, such as open-cell foam, porous tissue collections, and liquids, gels, and foams that include or cure to include flow channels.

In some embodiments, a material with a higher or lower density than GranuFoam® material may be desirable for the interface manifold **120** depending on the application. Among the many possible materials, the following may be used without limitation: GranuFoam® material; Foamex® technical foam ([www.foamex.com](http://www.foamex.com)); a molded bed of nails structure; a patterned grid material, such as those manufactured by Sercol Industrial Fabrics; 3D textiles, such as those manufactured by Baltex of Derby, U.K.; a gauze; a flexible channel-containing member; or a graft. Further, in some embodiments, ionic silver may be added to the interface manifold **120** by, for example, a micro bonding process. Other substances, such as anti-microbial agents, may be added to the interface manifold **120** as well.

In some embodiments, the interface manifold **120** may comprise a porous, hydrophobic material. The hydrophobic characteristics of the interface manifold **120** may prevent the interface manifold **120** from directly absorbing fluid, such as exudate, from the tissue site **104**, but allow the fluid to pass through.

In some embodiments, the dressing **324** may include a base layer **132**, an adhesive **136**, a sealing member **140**, a fluid management assembly **344**, and a conduit interface **148**. Components of the dressing **324** may be added or removed to suit a particular application. In some embodiments, the dressing **324** may be adapted to provide reduced pressure from the reduced-pressure source **128** to the interface manifold **120**, and to extract fluid from the tissue site **104** through the interface manifold **120**.

Referring to FIGS. 13-16B, the base layer **132** may have a periphery **152** surrounding a central portion **156**, and a plurality of apertures **160** disposed through the periphery **152** and the central portion **156**. The base layer **132** may also have corners **158** and edges **159**. The corners **158** and the edges **159** may be part of the periphery **152**. One of the

edges **159** may meet another of the edges **159** to define one of the corners **158**. Further, the base layer **132** may have a border **161** substantially surrounding the central portion **156** and positioned between the central portion **156** and the periphery **152**. In some embodiments, the border **161** may be free of the apertures **160**. In some embodiments, the base layer **132** may be adapted to cover the interface manifold **120** and tissue surrounding the tissue site **104** such that the central portion **156** of the base layer **132** is positioned adjacent to or proximate to the interface manifold **120**, and the periphery **152** of the base layer **132** is positioned adjacent to or proximate to tissue surrounding the tissue site **104**. In such embodiments, the periphery **152** of the base layer **132** may surround the interface manifold **120**. Further, the apertures **160** in the base layer **132** may be in fluid communication with the interface manifold **120** and tissue surrounding the tissue site **104**.

The apertures **160** in the base layer **132** may have any shape, such as, for example, circles, squares, stars, ovals, polygons, slits, complex curves, rectilinear shapes, triangles, or other shapes. The apertures **160** may be formed by cutting, by application of local RF energy, or other suitable techniques for forming an opening. Each of the apertures **160** of the plurality of apertures **160** may be substantially circular in shape, having a diameter and an area. The area of the apertures **160** described in the illustrative embodiments herein may be substantially similar to the area in other embodiments for the apertures **160** that may have non-circular shapes. Further, the area of each of the apertures **160** may be substantially the same, or each of the areas may vary, for example, based on the position of the aperture **160** in the base layer **132**. For example, the area of the apertures **160** in the periphery **152** of the base layer **132** may be larger than the area of the apertures **160** in the central portion **156** of the base layer **132**. The apertures **160** may have a uniform pattern or may be randomly distributed on the base layer **132**. The size and configuration of the apertures **160** may be designed to control the adherence of the dressing **124** to the epidermis **106** as described herein.

In some embodiments, the apertures **160** positioned in the periphery **152** may be apertures **160a**, the apertures **160** positioned at the corners **158** of the periphery **152** may be apertures **160b**, and the apertures **160** positioned in the central portion **156** may be apertures **160c**. In some embodiments, the apertures **160a** may have an area greater than the apertures **160b**. Further, in some embodiments, the apertures **160b** may have an area greater than the apertures **160c**. The dimensions of the base layer **132** may be increased or decreased, for example, substantially in proportion to one another to suit a particular application. Further, although the central portion **156**, the border **161**, and the periphery **152** of the base layer **132** are shown as having a substantially square shape, these and other components of the base layer **132** may have any shape to suit a particular application.

The base layer **132** may be a soft, pliable material suitable for providing a fluid seal with the tissue site **104** as described herein. For example, the base layer **132** may comprise a silicone gel, a soft silicone, hydrocolloid, hydrogel, polyurethane gel, polyolefin gel, hydrogenated styrenic copolymer gel, a foamed gel, a soft closed cell foam such as polyurethanes and polyolefins coated with an adhesive as described below, polyurethane, polyolefin, or hydrogenated styrenic copolymers. In some embodiments, the base layer **132** may include a silicone such as Scapa Soft-Pro®. The base layer **132** may have a thickness between about 500 microns ( $\mu\text{m}$ ) and about 1000 microns ( $\mu\text{m}$ ). In some embodiments, the base layer **132** may have a stiffness

between about 5 Shore OO and about 80 Shore OO. Further, in some embodiments, the base layer **132** may be comprised of hydrophobic or hydrophilic materials.

In some embodiments (not shown), the base layer **132** may be a hydrophobic-coated material. For example, the base layer **132** may be formed by coating a spaced material, such as, for example, woven, nonwoven, molded, or extruded mesh with a hydrophobic material. The hydrophobic material for the coating may be a soft silicone, for example. The base layer **132** may additionally or alternatively be a non-adherent copolymer mesh. In this manner, the adhesive **136** may extend through openings in the spaced material analogous to the apertures **160**.

In some embodiments, the adhesive **136** may be exposed to the apertures **160** in at least the periphery **152** of the base layer **132**. Further, in some embodiments, the adhesive **136** may be positioned adjacent to, or positioned in fluid communication with, the apertures **160** in at least the periphery **152** of the base layer **132**. Further, in some embodiments, the adhesive **136** may be exposed to or in fluid communication with tissue surrounding the tissue site **104** through the apertures **160** in the base layer **132**. As described herein and shown in FIG. **15**, the adhesive **136** may extend, deform, or be pressed through the plurality of apertures **160** to contact the epidermis **106** for securing the dressing **324** to, for example, tissue surrounding the tissue site **104**. The apertures **160** may provide sufficient contact of the adhesive **136** to the epidermis **106** to secure the dressing **124** about the tissue site **104**. However, the configuration of the apertures **160** and the adhesive **136**, described herein, may permit release and repositioning of the dressing **324** about the tissue site **104**.

In some embodiments, the apertures **160b** at the corners **158** of the periphery **152** may be smaller than the apertures **160a** in other portions of the periphery **152**. For a given geometry of the corners **158**, the smaller size of the apertures **160b** compared to the apertures **160a** may enhance or increase the surface area of the adhesive **136** exposed to the apertures **160b** and to tissue through the apertures **160b** at the corners **158**. The size and number of the apertures **160b** in the corners **158** may be adjusted as necessary, depending on the chosen geometry of the corners **158**, to enhance or increase the exposed surface area of the adhesive **136** as described above.

Similar to the apertures **160b** in the corners **158**, any of the apertures **160** may be adjusted in size and number to increase the surface area of the adhesive **136** exposed to or in fluid communication with the apertures **160** for a particular application or geometry of the base layer **132**. For example, in some embodiments (not shown) the apertures **160b**, or apertures of another size, may be positioned in the periphery **152** and at the border **161**. Similarly, the apertures **160b**, or apertures of another size, may be positioned as described above in other locations of the base layer **132** that may have a complex geometry or shape.

The adhesive **136** may be a medically-acceptable adhesive. In some embodiments, the adhesive **136** may be deformable or flowable. For example, the adhesive **136** may comprise an acrylic adhesive, rubber adhesive, high-tack silicone adhesive, polyurethane, or other adhesive substance. In some embodiments, the adhesive **136** may be a pressure-sensitive adhesive comprising an acrylic adhesive. The adhesive **136** may be a layer having substantially the same shape as the periphery **152** of the base layer **132**. In some embodiments, the adhesive **136** may be continuous or discontinuous. Discontinuities in the adhesive **136** may be provided by apertures (not shown) in the adhesive **136**.

Apertures in the adhesive **136** may be formed after application of the adhesive **136** or by coating the adhesive **136** in patterns on a carrier layer, such as, for example, a side of the sealing member **140** adapted to face the epidermis **106**. Further, apertures in the adhesive **136** may be sized to control the amount of the adhesive **136** extending through the apertures **160** in the base layer **132** to reach the epidermis **106**. Apertures in the adhesive **136** may also be sized to enhance the Moisture Vapor Transfer Rate (MVTR) of the dressing **124**, described further herein.

Factors that may be utilized to control the adhesion strength of the dressing **324** may include the diameter, area, and number of the apertures **160** in the base layer **132**, the thickness of the base layer **132**, the thickness and amount of the adhesive **136**, and the tackiness of the adhesive **136**. An increase in the amount of the adhesive **136** extending through the apertures **160** may correspond to an increase in the adhesion strength of the dressing **324**. A decrease in the thickness of the base layer **132** may correspond to an increase in the amount of adhesive **136** extending through the apertures **160**. Thus, the diameter, area, and configuration of the apertures **160**, the thickness of the base layer **132**, and the amount and tackiness of the adhesive utilized may be varied to provide a desired adhesion strength for the dressing **324**.

In some embodiments, the tackiness of the adhesive **136** may vary in different locations of the base layer **132**. For example, in locations of the base layer **132** where the apertures **160** are comparatively large, such as the apertures **160a**, the adhesive **136** may have a lower tackiness than other locations of the base layer **132** where the apertures **160** are smaller, such as the apertures **160b** and **160c**. In this manner, locations of the base layer **132** having larger apertures **160** and lower tackiness adhesive **136** may have an adhesion strength comparable to locations having smaller apertures **160** and higher tackiness adhesive **136**.

A release liner **162** may be attached to or positioned adjacent to the base layer **132** to protect the adhesive **136** prior to application of the dressing **324** to the tissue site **104**. Prior to application of the dressing **324** to the tissue site **104**, the base layer **132** may be positioned between the sealing member **140** and the release liner **162**. Removal of the release liner **162** may expose the base layer **132** and the adhesive **136** for application of the dressing **324** to the tissue site **104**. The release liner **162** may also provide stiffness to assist with, for example, deployment of the dressing **324**. The release liner **162** may be, for example, a casting paper, a film, or polyethylene. Further, the release liner **162** may be a polyester material such as polyethylene terephthalate (PET), or similar polar semi-crystalline polymer. The use of a polar semi-crystalline polymer for the release liner **162** may substantially preclude wrinkling or other deformation of the dressing **324**. For example, the polar semi-crystalline polymer may be highly orientated and resistant to softening, swelling, or other deformation that may occur when brought into contact with components of the dressing **324**, or when subjected to temperature or environmental variations, or sterilization. Further, a release agent may be disposed on a side of the release liner **162** that is configured to contact the base layer **132**. For example, the release agent may be a silicone coating and may have a release factor suitable to facilitate removal of the release liner **162** by hand and without damaging or deforming the dressing **324**. In some embodiments, the release agent may be fluorosilicone. In other embodiments, the release liner **162** may be uncoated or otherwise used without a release agent. In some embodiments, the base layer **132** may be adapted to be positioned

in direct contact with the tissue site **104**. In some embodiments, the base layer **132** may include a non-adherent mesh and one or more wicking layers of the dressing as discussed herein may be positioned between the base layer **132** and a dressing sealing member as discussed herein.

Continuing with FIGS. **13-16B**, the sealing member **140** may also be referred to as a dressing sealing member **140**. The sealing member **140** may have a periphery **164** and a central portion **168**. The sealing member **140** may additionally include an aperture **170**. The periphery **164** of the sealing member **140** may be positioned proximate to the periphery **152** of the base layer **132** such that the central portion **168** of the sealing member **140** and the central portion **156** of the base layer **132** define an enclosure **172**. The adhesive **136** may be positioned at least between the periphery **164** of the sealing member **140** and the periphery **152** of the base layer **132**. The sealing member **140** may cover the tissue site **104** and the interface manifold **120** to provide a fluid seal and a sealed space **174** between the tissue site **104** and the sealing member **140** of the dressing **324**. Further, the sealing member **140** may cover other tissue, such as a portion of the epidermis **106**, surrounding the tissue site **104** to provide the fluid seal between the sealing member **140** and the tissue site **104**. In some embodiments, a portion of the periphery **164** of the sealing member **140** may extend beyond the periphery **152** of the base layer **132** and into direct contact with tissue surrounding the tissue site **104**. In other embodiments, the periphery **164** of the sealing member **140**, for example, may be positioned in contact with tissue surrounding the tissue site **104** to provide the sealed space **174** without the base layer **132**. Thus, the adhesive **136** may also be positioned at least between the periphery **164** of the sealing member **140** and tissue, such as the epidermis **106**, surrounding the tissue site **104**. The adhesive **136** may be disposed on a surface of the sealing member **140** adapted to face the tissue site **104** and the base layer **132**.

The sealing member **140** may be formed from any material that allows for a fluid seal. A fluid seal may be a seal adequate to maintain reduced pressure at a desired site given the particular reduced pressure source or system involved. The sealing member **140** may comprise, for example, one or more of the following materials: hydrophilic polyurethane; cellulose; hydrophilic polyamides; polyvinyl alcohol; polyvinyl pyrrolidone; hydrophilic acrylics; hydrophilic silicone elastomers; an INSPIRE 2301 material from Expopack Advanced Coatings of Wrexham, United Kingdom having, for example, an MVTR (inverted cup technique) of 14400 g/m<sup>2</sup>/24 hours and a thickness of about 30 microns; a thin, uncoated polymer drape; natural rubbers; polyisoprene; styrene butadiene rubber; chloroprene rubber; polybutadiene; nitrile rubber; butyl rubber; ethylene propylene rubber; ethylene propylene diene monomer; chlorosulfonated polyethylene; polysulfide rubber; polyurethane (PU); EVA film; co-polyester; silicones; a silicone drape; a 3M Tegaderm® drape; a polyurethane (PU) drape such as one available from Avery Dennison Corporation of Pasadena, Calif.; a polyurethane (PU) film such as Scapa Bioflex 130 polyurethane Film®; polyether block polyamide copolymer (PEBAX), for example, from Arkema, France; Expopack 2327; or other appropriate material.

The sealing member **140** may be vapor permeable and liquid impermeable, thereby allowing vapor and inhibiting liquids from exiting the sealed space **174** provided by the dressing **324**. In some embodiments, the sealing member **140** may be a flexible, breathable film, membrane, or sheet having a high MVTR of, for example, at least about 300

g/m<sup>2</sup> per 24 hours. In other embodiments, a low or no vapor transfer drape may be used. The sealing member **140** may comprise a range of medically suitable films having a thickness between about 15 microns (μm) to about 50 microns (μm).

The fluid management assembly **344** may be disposed in the enclosure **172**. In some embodiments, the fluid management assembly **344** may include one or more dressing wicking layers **345**. For example, a first dressing wicking layer **376**, a second dressing wicking layer **378**, and a third dressing wicking layer **381**. The one or more dressing wicking layers **345** may wick fluid along a surface of one or more of the first dressing wicking layer **376**, the second dressing wicking layer **378**, and the third dressing wicking layer **381**. For example, one or more dressing wicking layer **345** may wick or otherwise transport fluid in a lateral direction along the surfaces of one of the first dressing wicking layer **376**, the second dressing wicking layer **378**, or the third dressing wicking layer **381**, respectively. The surface of the first dressing wicking layer **376** may be normal relative to the thickness of the first dressing wicking layer **176**. The surface of the second dressing wicking layer **378** may be normal relative to the thickness of the second dressing wicking layer **378**. The surface of the third dressing wicking layer **381** may be normal relative to the thickness of the third dressing wicking layer **381**. The wicking of fluid along the one or more dressing wicking layers **345** may enhance the distribution of the fluid. A laminate combination of the first dressing wicking layer **376**, the second dressing wicking layer **378**, and the third dressing wicking layer **381** may be adapted as described herein to maintain an open structure, resistant to blockage, capable of maintaining fluid communication with, for example, the tissue site **104**.

Referring to the embodiments of the fluid management assembly **344** depicted in FIGS. **13**, **14**, and **17**, a peripheral portion **186** of the first dressing wicking layer **376** may be coupled to a peripheral portion **187** of the third dressing wicking layer **381** to define a wicking layer enclosure **389** between the first dressing wicking layer **376** and the third dressing wicking layer **381**. In some embodiments, the wicking layer enclosure **389** may surround or otherwise encapsulate the second dressing wicking layer **378** between the first dressing wicking layer **376** and the third dressing wicking layer **381**. Materials suitable for the first dressing wicking layer **376**, the second dressing wicking layer **378**, and the third dressing wicking layer **381** may include, without limitation, any material having a grain structure capable of wicking fluid as described herein, such as, for example, LIBELTEX TDL2, 80 gsm, or similar materials, which may be non-woven.

The fluid management assembly **344** may be manufactured as a pre-laminated structure, or supplied as individual layers of material that can be stacked upon one another as described above. Individual layers of the fluid management assembly **344** may be bonded or otherwise secured to one another without adversely affecting fluid management by, for example, utilizing a solvent or non-solvent adhesive, or by thermal welding. Further, the fluid management assembly **344** may be coupled to the border **161** of the base layer **132** in any suitable manner, such as, for example, by a weld or an adhesive. The border **161**, being free of the apertures **160** as described above, may provide a flexible barrier between the fluid management assembly **344** and the tissue site **104** for enhancing comfort. In some embodiments, the base layer **132** may include a non-adherent interface. The non-adherent

interface may be used with VLUs to accommodate a sensitive and/or a sore tissue site. The non-adherent interface may include a co-polymer mesh.

The dressing **324** may be modified in various embodiments to suit a particular application. The first dressing wicking layer **376**, the second dressing wicking layer **378**, and the third dressing wicking layer **381** may wick or draw fluid away from the tissue site **104** for transport to a location exterior to the dressing **324**. Further, the configuration of the first dressing wicking layer **376**, the second dressing wicking layer **378**, and the third dressing wicking layer **381** described herein may preference fluid away from the tissue site **104** and prevent the fluid from returning to the tissue site **104** prior to removal of the fluid from the dressing **324**, for example, by the application of reduced pressure. The wicking layer enclosure **389** may enhance this ability to preference fluid away from the tissue site **104** and to prevent the fluid from returning to the tissue site **104**. In some embodiments, the dressing **324** may comprise a winged profile to allow for greater adhesion between the dressing **324** and a leg or an arm, for example.

The dressing **324** may be further modified in various embodiments that may be suitable for some applications that communicate fluid from the tissue site **104** exterior to the dressing **324**. For example, the fluid management assembly **344** may be omitted from the dressing **324**, and a dressing manifold (not shown) may be positioned in the enclosure **172** in place of the fluid management assembly **344**. The dressing manifold may be configured as a layer and may be comprised of any material suitable for removing fluids from a tissue site through a plurality of pores, pathways, or flow channels as described herein, such as, without limitation, a foam, a woven material, a cast silicone, a polyurethane material, or any of the materials recited above for the interface manifold **120**. Further, in some embodiments, the dressing **324** may be modified by omitting the base layer **132** and replacing the fluid management assembly **344** with the above-described dressing manifold. In such an embodiment, the dressing **324** may comprise the sealing member **140** and the dressing manifold for disposing in the sealed space **174** between the sealing member **140** and the tissue site **104**.

In some embodiments, the fluid management assembly **344** may include a film, a first wicking layer, and a second wicking layer. The film may be a base layer of adhesive coated polyurethane (PU) film. The adhesive coated on the film may adhere the first wicking layer to an inner surface of the fluid management assembly (i.e. a surface forming the wicking layer enclosure **188** and exposed to the wicking layer enclosure **188**). The first wicking layer may be stacked or placed below or underneath the second wicking layer such that fluid (such a fluid of exudate) is communicated from the first wicking layer to the second wicking layer and out the conduit interface **148**. The first wicking layer may have a wider base and a higher density relative to the second wicking layer. The first wicking layer may have a surface area that is greater than a surface area of the second wicking layer. The first wicking layer may have a greater thickness (such as 50 mm) relative to the second wicking layer thickness (such as 20 mm). The first wicking layer may include a profile to spread the fluid out over an entire surface of the first wicking layer to increase evaporation. The second wicking layer may be used to pull fluid from the wound towards to the conduit interface **148**. In some embodiments, the second wicking layer may alternatively or additionally include a profile like the profile of the first wicking layer to spread fluid out over an entire surface of the second wicking layer. The profile of the second wicking layer may also be

used to increase evaporation. In some embodiments, the fluid management assembly **344** may include a film positioned to adhere to the second wicking layer on a surface of the second wicking layer opposite the first wicking layer. The film positioned to adhere to the second wicking layer may include one or more of the same properties as the film that may adhere to the first wicking layer described herein.

Referring to FIGS. **13**, **14**, and **18**, the conduit interface **148** may be positioned proximate to the sealing member **140** and in fluid communication with the enclosure **172** of the dressing **324**. For example, the conduit interface **148** may be in fluid communication with the dressing **324** through the aperture **170** in the sealing member **140**. The conduit interface **148** may provide reduced pressure from the reduced-pressure source **128** to the dressing **324**. The conduit interface **148** may also be adapted to be positioned in fluid communication with the optional interface manifold **120**. An optional liquid trap **192** may be positioned in fluid communication between the dressing **324** and the reduced-pressure source **128**. The liquid trap **192** may be any suitable containment device having a sealed internal volume capable of retaining liquid, such as condensate or other liquids.

The conduit interface **148** may comprise a medical-grade, soft polymer or other pliable material. As non-limiting examples, the conduit interface **148** may be formed from polyurethane, polyethylene, polyvinyl chloride (PVC), fluorosilicone, or ethylene-propylene. In some illustrative, non-limiting embodiments, conduit interface **148** may be molded from DEHP-free PVC. The conduit interface **148** may be formed in any suitable manner such as by molding, casting, machining, or extruding. Further, the conduit interface **148** may be formed as an integral unit or as individual components and may be coupled to the dressing **324** by, for example, adhesive or welding.

In some embodiments, the conduit interface **148** may be formed of an absorbent material having absorbent and evaporative properties. The absorbent material may be vapor permeable and liquid impermeable, thereby being configured to permit vapor to be absorbed into and evaporated from the material through permeation while inhibiting permeation of liquids. The absorbent material may be, for example, a hydrophilic polymer such as a hydrophilic polyurethane. Although the term hydrophilic polymer may be used in the illustrative embodiments that follow, any absorbent material having the properties described herein may be suitable for use in the system **302**. Further, the absorbent material or hydrophilic polymer may be suitable for use in various components of the system **302** as described herein.

The use of such a hydrophilic polymer for the conduit interface **148** may permit liquids in the conduit interface **148** to evaporate, or otherwise dissipate, during operation. For example, the hydrophilic polymer may allow the liquid to permeate or pass through the conduit interface **148** as vapor, in a gaseous phase, and evaporate into the atmosphere external to the conduit interface **148**. Such liquids may be, for example, condensate or other liquids. Condensate may form, for example, as a result of a decrease in temperature within the conduit interface **148**, or other components of the system **302**, relative to the temperature at the tissue site **104**. Removal or dissipation of liquids from the conduit interface **148** may increase visual appeal and prevent odor. Further, such removal of liquids may also increase efficiency and reliability by reducing blockages and other interference with the components of the system **302**.

Similar to the conduit interface **148**, the liquid trap **192**, and other components of the system **302**, may also be formed of an absorbent material or a hydrophilic polymer.

The absorptive and evaporative properties of the hydrophilic polymer may also facilitate removal and dissipation of liquids residing in the liquid trap **192**, and other components of the system **302**, by evaporation. Such evaporation may leave behind a substantially solid or gel-like waste. The substantially solid or gel-like waste may be cheaper to dispose than liquids, providing a cost savings for operation of the system **302**. The hydrophilic polymer may be used for other components in the system **302** where the management of liquids is beneficial.

In some embodiments, the absorbent material or hydrophilic polymer may have an absorbent capacity in a saturated state that is substantially equivalent to the mass of the hydrophilic polymer in an unsaturated state. The hydrophilic polymer may be fully saturated with vapor in the saturated state and substantially free of vapor in the unsaturated state. In both the saturated state and the unsaturated state, the hydrophilic polymer may retain substantially the same physical, mechanical, and structural properties. For example, the hydrophilic polymer may have a hardness in the unsaturated state that is substantially the same as a hardness of the hydrophilic polymer in the saturated state. The hydrophilic polymer and the components of the system **302** incorporating the hydrophilic polymer may also have a size that is substantially the same in both the unsaturated state and the saturated state. Further, the hydrophilic polymer may remain dry, cool to the touch, and pneumatically sealed in the saturated state and the unsaturated state. The hydrophilic polymer may also remain substantially the same color in the saturated state and the unsaturated state. In this manner, this hydrophilic polymer may retain sufficient strength and other physical properties to remain suitable for use in the system **302**. An example of such a hydrophilic polymer is offered under the trade name Techophilic HP-93A-100, available from The Lubrizol Corporation of Wickliffe, Ohio, United States. Techophilic HP-93A-100 is an absorbent hydrophilic thermoplastic polyurethane capable of absorbing 100% of the unsaturated mass of the polyurethane in water and having a durometer or Shore Hardness of about 83 Shore A.

The conduit interface **148** may carry an odor filter **194** adapted to substantially preclude the passage of odors from the tissue site **104** out of the sealed space **174**. Further, the conduit interface **148** may carry a primary hydrophobic filter **195** adapted to substantially preclude the passage of liquids through the primary hydrophobic filter **195**. The odor filter **194** and the primary hydrophobic filter **195** may be disposed in the conduit interface **148** or other suitable location such that fluid communication between the reduced-pressure source **128**, or optional therapy unit **130**, and the dressing **324** is provided through the odor filter **194** and the primary hydrophobic filter **195**. In some embodiments, the odor filter **194** and the primary hydrophobic filter **195** may be secured within the conduit interface **148** in any suitable manner, such as by adhesive or welding. In other embodiments, the odor filter **194** or the primary hydrophobic filter **195** may be omitted, or positioned proximate to any exit location in the system **302** or the dressing **324** that is in fluid communication with the atmosphere, the reduced-pressure source **128**, or the optional therapy unit **130**.

The odor filter **194** may be comprised of a carbon material in the form of a layer or particulate. For example, the odor filter **194** may comprise a woven carbon cloth filter such as those manufactured by Chemviron Carbon, Ltd. of Lancashire, United Kingdom. The primary hydrophobic filter **195** may be comprised of a material that is liquid impermeable and vapor permeable. For example, the primary hydro-

phobic filter **195** may comprise a material manufactured under the designation MMT-314 by W.L. Gore & Associates, Inc. of Newark, Del., United States, or similar materials. The primary hydrophobic filter **195** may be provided in the form of a membrane or layer.

Continuing with FIGS. **13**, **14**, and **18**, the reduced-pressure source **128** may provide reduced pressure to the dressing **324** and the sealed space **174**. The reduced-pressure source **128** may be any suitable device for providing reduced pressure, such as, for example, a vacuum pump, wall suction, hand pump, manual pump, or other source. In some embodiments, the reduced-pressure source **128** may be a component of the therapy unit **130**. The therapy unit **130** may include control circuitry and sensors, such as a pressure sensor, that may be configured to monitor reduced pressure at the tissue site **104**. The therapy unit **130** may also be configured to control the amount of reduced pressure from the reduced-pressure source **128** being applied to the tissue site **104** according to a user input and a reduced-pressure feedback signal received from the tissue site **104**. In some embodiments, the reduced pressure source **128** (such as a manual pump, hand pump, or the like) may comprise a container or may be fluidly connected to a container that receives fluid collected from the tissue site **104**. Thus, when the reduced pressure source **128** generates reduced pressure, fluid may be communicated from the tissue site, through the dressing, through the bridge, and received and stored in the container of the reduced pressure source **128** or fluidly connected to the reduced pressure source **128**.

As used herein, “reduced pressure” may refer to a pressure less than the ambient pressure at a tissue site being subjected to treatment. In some embodiments, the reduced pressure may be less than the atmospheric pressure. Further, in some embodiments, the reduced pressure may also be less than a hydrostatic pressure at a tissue site. Unless otherwise indicated, values of pressure stated herein are gauge pressures. While the amount and nature of reduced pressure applied to a tissue site may vary according to the application, in some embodiments, the reduced pressure may be between  $-5$  mm Hg and  $-500$  mm Hg. In some embodiments, the reduced pressure may be between  $-100$  mm Hg and  $-200$  mm Hg.

The reduced pressure delivered may be, for example, constant, varied, patterned, or random. Further, the reduced pressure may be delivered continuously or intermittently. Although the terms “vacuum” and “negative pressure” may be used to describe the pressure applied to a tissue site, the actual pressure applied to the tissue site may be more than the pressure normally associated with a complete vacuum. Consistent with the use herein, an increase in reduced pressure or vacuum pressure may refer to a relative reduction in absolute pressure. Further, an increase in reduced pressure may correspond to a reduction in pressure (more negative relative to ambient pressure), and a decrease in reduced pressure may correspond to an increase in pressure (less negative relative to ambient pressure).

Referring to FIGS. **13** and **18**, a conduit **196** having an internal lumen **197** may be coupled in fluid communication between the reduced-pressure source **128** and the dressing **324**. The internal lumen **197** may have an internal diameter between about 0.5 millimeters to about 3.0 millimeters. In some embodiments, the internal diameter of the internal lumen **197** may be between about 1 millimeter to about 2 millimeters. The conduit interface **148** may be coupled in fluid communication with the dressing **324** and adapted to connect between the conduit **196** and the dressing **324** for providing fluid communication with the reduced-pressure

source 128. The conduit interface 148 may be fluidly coupled to the conduit 196 in any suitable manner, such as, for example, by an adhesive, solvent or non-solvent bonding, welding, or interference fit. The aperture 170 in the sealing member 140 may provide fluid communication between the dressing 324 and the conduit interface 148. For example, the conduit interface 148 may be in fluid communication with the enclosure 172 or the sealed space 174 through the aperture 170 in the sealing member 140. In some embodiments, the conduit 196 may be inserted into the dressing 324 through the aperture 170 in the sealing member 140 to provide fluid communication with the reduced-pressure source 128 without use of the conduit interface 148. The reduced-pressure source 128 may also be directly coupled in fluid communication with the dressing 324 or the sealing member 140 without use of the conduit 196. In some embodiments, the conduit 196 may be, for example, a flexible polymer tube. A distal end of the conduit 196 may include a coupling 198 for attachment to the reduced-pressure source 128.

The conduit 196 may have a secondary hydrophobic filter 199 disposed in the internal lumen 197 such that fluid communication between the reduced-pressure source 128 and the dressing 324 is provided through the secondary hydrophobic filter 199. The secondary hydrophobic filter 199 may be, for example, a porous, sintered polymer cylinder sized to fit the dimensions of the internal lumen 197 to substantially preclude liquid from bypassing the cylinder. The secondary hydrophobic filter 199 may also be treated with an absorbent material adapted to swell when brought into contact with liquid to block the flow of the liquid. The secondary hydrophobic filter 199 may be positioned at any location within the internal lumen 197. However, positioning the secondary hydrophobic filter 199 within the internal lumen 197 closer toward the reduced-pressure source 128, rather than the dressing 324, may allow a user to detect the presence of liquid in the internal lumen 197.

In some embodiments, the conduit 196 and the coupling 198 may be formed of an absorbent material or a hydrophilic polymer as described above for the conduit interface 148. In this manner, the conduit 196 and the coupling 198 may permit liquids in the conduit 196 and the coupling 198 to evaporate, or otherwise dissipate, as described above for the conduit interface 148. The conduit 196 and the coupling 198 may be, for example, molded from the hydrophilic polymer separately, as individual components, or together as an integral component. Further, a wall of the conduit 196 defining the internal lumen 197 may be extruded from the hydrophilic polymer. The conduit 196 may be less than about 1 meter in length, but may have any length to suit a particular application.

Referring to FIG. 19, another embodiment of a fluid management assembly 444 suitable for use with the dressing 424 and the system 402 is shown. The fluid management assembly 444 may include one or more dressing wicking layers 484 such as a first dressing wicking layer 476, a second dressing wicking layer 478, and a third dressing wicking layer 480 comprised of substantially the same materials and properties as those described above in connection with the fluid management assembly 144. Thus, the first dressing wicking layer 476, the second dressing wicking layer 478, and the third dressing wicking layer 480 may be analogous to the first dressing wicking layer 376, the second dressing wicking layer 378, and the third dressing wicking layer 381, respectively.

In the fluid management assembly 444, the third dressing wicking layer 480 may have a peripheral portion 287. The

third dressing wicking layer 480 and the peripheral portion 287 of the first dressing wicking layer 476 may be positioned in contact with the sealing member 140. The second dressing wicking layer 478 may have a peripheral portion 285 extending beyond the peripheral portion 287 of the third dressing wicking layer 480. The second dressing wicking layer 478 may be positioned adjacent to or proximate to the first dressing wicking layer 280 such that the peripheral portion 285 of the second dressing wicking layer 478 is in contact with the sealing member 140 surrounding the peripheral portion 287 of the third dressing wicking layer 480. Similarly, the first dressing wicking layer 476 may have a peripheral portion 286 extending beyond the peripheral portion 285 of the second dressing wicking layer 478. The first dressing wicking layer 476 may be positioned adjacent to or proximate to the second dressing wicking layer 478 such that the peripheral portion 286 of the first dressing wicking layer 476 is in contact with the sealing member 140 surrounding the peripheral portion 285 of the second dressing wicking layer 478. Further, the first dressing wicking layer 476 may be positioned adjacent to or proximate to the base layer 132. Thus, at least the peripheral portion 287, the peripheral portion 285, and the peripheral portion 286 may be coupled to the sealing member 140, such as, for example, by an adhesive coating disposed on a surface of the sealing member 140 facing the base layer 132. The adhesive coating may be analogous to the adhesive 136 that may be applied across the surface of the sealing member 140 facing the base layer 132. The third dressing wicking layer 480, the second dressing wicking layer 478, and the first dressing wicking layer 476 may respectively have increasing surface areas to enhance contact with the adhesive coating described above. In other embodiments, the fluid management assembly 444 may include any number of absorbent layers and wicking layers for treating a particular tissue site.

In operation, according to some illustrative embodiments, the interface manifold 120 may be disposed against or proximate to the tissue site 104. The dressing 324, 424 may be applied over or covering the interface manifold 120 and the tissue site 104 to form the sealed space 174. For example, the base layer 132 may be applied covering the interface manifold 120 and tissue surrounding the tissue site 104. The materials described above for the base layer 132 may have a tackiness that may hold the dressing 324 or 424 initially in position. The tackiness may be such that if an adjustment is desired, the dressing 324, 424 may be removed and reapplied. Once the dressing 324, 424 is in the desired position, a force may be applied, such as hand pressure, on a side of the sealing member 140 facing outward or opposite the tissue site 104. The force applied to the sealing member 140 may cause at least some portion of the adhesive 136 to penetrate or extend through the plurality of apertures 160 and into contact with tissue surrounding the tissue site 104, such as the epidermis 106, to releasably adhere the dressing 324, 424 about the tissue site 104. In this manner, the configuration of the dressing 324, 424 described herein may provide an effective and reliable seal against challenging anatomical surfaces, such as an elbow or heel, at and around the tissue site 104. Further, the dressing 324, 424 may permit re-application or re-positioning to, for example, correct air leaks caused by creases and other discontinuities in the dressing 324, 424 and the tissue site 104. The ability to rectify leaks may increase the reliability of the therapy and reduce power consumption.

As the dressing 324, 424 comes into contact with fluid from the tissue site 104, the fluid may move through the apertures 160 toward the fluid management assembly 344,



444. The fluid management assembly 344, 444 may wick or otherwise move the fluid away from the tissue site 104, and through the interface manifold 120, if equipped. As described above, the interface manifold 120 may be adapted to communicate fluid from the tissue site 104 rather than store the fluid. Thus, the fluid management assembly 344, 444 may be adapted to wick, pull, draw, or otherwise attract fluid from the tissue site 104 through the interface manifold 120. In the fluid management assembly 344, 444 the fluid may initially come into contact with the first dressing wicking layer 376, 476. The first dressing wicking layer 376, 476 may distribute the fluid laterally along the surface of the first dressing wicking layer 376, 476 for absorption or removal from the dressing 324, 424. Similarly, fluid may come into contact with the third dressing wicking layer 381, 480 and may be distributed laterally along the surface of the third dressing wicking layer 381, 480 for absorption or removal from the dressing 324, 424.

Referring to FIGS. 21-23, in some embodiments, a bridge assembly 710 may extend away from the tissue site 104 and the dressing 124, 324, 424 to define a fluid passageway between the tissue site 104 and the reduced-pressure source 128. For example, the bridge assembly 710 may be coupled in fluid communication between the dressing 124, 324, 424 and the reduced-pressure source 128. However, other applications for the bridge assembly 710 are possible. In some embodiments, the bridge assembly 710 may include a bridge 720, a sealing apparatus 730, and the conduit interface 148.

The bridge 720 may include a receiving end 734 separated or spaced apart from a transmitting end 738 by a length 740. The receiving end 734 may have a receiving end aperture 742, and the transmitting end 738 may have a transmitting end aperture 746. The receiving end 734 and the receiving end aperture 742 may be in fluid communication with the transmitting end 738 and the transmitting end aperture 746 through the length 740 of the bridge 720.

The conduit interface 148 may be adapted to be fluidly coupled to the receiving end 734 of the bridge 720 through, for example, the receiving end aperture 742. Thus, the conduit interface 148 may be in fluid communication with the transmitting end 738 through the length 740 of the bridge 720. The sealing apparatus 730 may be positioned about the transmitting end aperture 746 and between the transmitting end 738 and the dressing 124, 324, 424 for coupling the transmitting end 738 to the dressing 124, 324, 424 and in fluid communication with the dressing 124 through the transmitting end aperture 746. Thus, the conduit interface 148 may be positioned in fluid communication with the dressing 124, 324, 424 through the bridge 720. The sealing apparatus 730 may be any suitable device for making the connections described above, such as, without limitation, an adhesive ring or weld.

In some embodiments, the bridge 720 may include one or more wicking layers 754, and a bridge sealing member 758. The bridge sealing member 758 may extend along the length 740 of the bridge 720. Further, the bridge sealing member 758 may define an internal passageway 784. The one or more wicking layers 754 may be disposed within the internal passageway 784 of the bridge sealing member 758. In some embodiments, the bridge sealing member 758 may entirely surround the one or more wicking layers 754. Further, in some embodiments, the bridge sealing member 758 may encapsulate the one or more wicking layers 754.

In some embodiments, the one or more wicking layers 754 may include at least one of a first wicking layer 780, a second wicking layer 781, or a third wicking layer 782. In some embodiments, the first wicking layer 780, the second

wicking layer 781, and the third wicking layer 782 may be referred to as a first bridge wicking layer, a second bridge wicking layer, and a third bridge wicking layer, respectively. Each of the one or more wicking layers 754 may extend along the length 740 of the bridge 720, and may be disposed within the internal passageway 784 that may be defined by the bridge sealing member 758. The first wicking layer 780, the second wicking layer 781, and the third wicking layer 782 may each be comprised of the same materials recited above for the first dressing wicking layer 176 and the second dressing wicking layer 180.

A periphery or edge of the first wicking layer 780 may be coupled to a periphery or edge of the second wicking layer 781 in any suitable manner, such as, for example, by a weld 786, to define the internal passageway 784 of the bridge envelope 750. A periphery or edge of the second wicking layer 781 may be coupled to a periphery or edge of the third wicking layer 782 in any suitable manner, such as, for example, by a weld 786, to define the internal passageway 784 of the bridge sealing member 758. The second wicking layer 781 may be positioned between the first wicking layer 780 and the third wicking layer 782. In some embodiments, the one or more wicking layers 754 (such as the first wicking layer 780, the second wicking layer 781, and the third wicking layer 782) may be positioned and sealed between the first sealing layer 788 and the second sealing layer 790 without a weld (such as weld 786) coupling the one or more wicking layers 754. In some embodiments, the one or more wicking layers 754 may be separated from each other or may be held together using

The first wicking layer 780, the second wicking layer 781, and the third wicking layer 782 may each include a fluid acquisition surface 772 and a fluid distribution surface 774. The fluid distribution surface 774 may be positioned on an opposite side of the first wicking layer 780, the second wicking layer 781, and the third wicking layer 782 from the fluid acquisition surface 772. The fluid acquisition surface 772 of each of the first wicking layer 780, the second wicking layer 781, and the third wicking layer 782 may face in a direction of the first sealing layer 788. Further, the fluid distribution surface 774 of each of the first wicking layer 780, the second wicking layer 781, and the third wicking layer 782 may face in a direction of the second sealing layer 790. The fluid acquisition surface 772 of each of the first wicking layer 780, the second wicking layer 781, and the third wicking layer 782 may face in a direction of the second sealing layer 790. The fluid distribution surface 774 of each of the first wicking layer 780, the second wicking layer 781, and the third wicking layer 782 may face in a direction of the first sealing layer 788. In some embodiments, a fluid acquisition surface 772 of the first wicking layer 780 may face a fluid acquisition surface 772 of the second wicking layer 781. In some embodiments, a fluid acquisition surface 772 of the second wicking layer 781 may face a fluid acquisition surface 772 of the third wicking layer 782. In some embodiments, a fluid distribution surface 774 of the first wicking layer 780 may face a fluid distribution surface 774 of the second wicking layer 781. In some embodiments, a fluid distribution surface 774 of the second wicking layer 781 may face a fluid distribution surface 774 of the third wicking layer 782.

In some embodiments, at least a portion of the first wicking layer 780 may be in direct contact with at least a portion of the second wicking layer 781. In some embodiments, at least a portion of the first wicking layer 780 may be spaced apart or separated from the second wicking layer 781 by an internal volume 760. In some embodiments, at

least a portion of the second wicking layer **781** may be in direct contact with at least a portion of the third wicking layer **782**. In some embodiments, at least a portion of the second wicking layer **781** may be spaced apart or separated from the third wicking layer **782** by an internal volume **706**. In some embodiments, the fluid distribution surface **774** may include a plurality of longitudinal fibers **791** oriented substantially in a longitudinal direction along the length **740** of the bridge **720**. Further, in some embodiments, the fluid acquisition surface **772** may include a plurality of vertical fibers **793** oriented substantially normal relative to the longitudinal fibers **791**.

In some embodiments, the one or more wicking layers **754** may include a first set of one or more bridge wicking layers and a second set of one or more bridge wicking layers. The first set of one or more bridge wicking layers and the second set of one or more bridge wicking layers may each extend along the length **740** of the storage bridge **720**, and may be disposed within an internal passageway **784** that may be defined by the bridge sealing member **758**. A periphery or edge of at least one bridge wicking layer of the first set of one or more bridge wicking layers may be coupled to a periphery or edge of at least one bridge wicking layer of the second set of one or more bridge wicking layers in any suitable manner, such as, for example, by a weld **786**, to define the internal volume **760** of the bridge envelope **750**. A bridge absorbent (such as bridge absorbent **354**) may be positioned between the first set of one or more bridge wicking layers and the second set of one or more bridge wicking layers. At least one bridge wicking layer of the first set of one or more bridge wicking layers and at least one bridge wicking layer of the second set of one or more bridge wicking layers may each include the fluid acquisition surface **772** and the fluid distribution surface **774**. The fluid distribution surface **774** may be positioned on an opposite side of the at least one bridge wicking layer of the first set of one or more bridge wicking layers and the at least one bridge wicking layer of the second set of one or more bridge wicking layers from the fluid acquisition surface **772**. Further, the fluid distribution surface **774** of the at least one bridge wicking layer of the first set of one or more bridge wicking layers and the at least one bridge wicking layer of the second set of one or more bridge wicking layers may face the bridge absorbent (such as bridge absorbent **354**). In some embodiments, at least a portion of the bridge absorbent may be spaced apart or separated from the fluid distribution surface **774** of the at least one bridge wicking layer of the first set of one or more bridge wicking layers and the at least one bridge wicking layer of the second set of one or more bridge wicking layers.

In some embodiments, the internal passageway **784** may house a film, a first wicking layer, a second wicking layer. The film may be a base layer of adhesive coated polyurethane (PU) film. The adhesive coated on the film may adhere the first wicking layer to an inner surface of the bridge sealing member **758**. The first wicking layer may be stacked or placed below or underneath the second wicking layer such that fluid (such a fluid of exudate) is communicated from the first wicking layer to the second wicking layer and out the conduit interface **148**. The first wicking layer may have a wider base and a higher density relative to the second wicking layer. The first wicking layer may have a greater thickness (such as 50 mm) relative to the second wicking layer thickness (such as 20 mm). The first wicking layer may include a profile to spread the fluid out over an entire surface of the first wicking layer to increase evaporation. The second wicking layer may be used to pull fluid from the wound

towards to the conduit interface **148**. In some embodiments, the second wicking layer may alternatively or additionally include a profile like the profile of the first wicking layer to spread fluid out over an entire surface of the second wicking layer. The profile of the second wicking layer may also be used to increase evaporation.

The bridge sealing member **758** may define the internal passageway **784**. The internal passageway **784** may be in fluid communication between the receiving end **734** and the transmitting end **738** of the bridge **720**. In some embodiments, the bridge sealing member **758** may entirely surround the one or more wicking layers **754**. In some embodiments, the bridge sealing member **758** may sealingly enclose the one or more wicking layers **754** between the receiving end **734** and the transmitting end **738** of the bridge **720**.

The bridge sealing member **758** may be comprised of similar materials described herein for the dressing sealing member **140**. For example, in some embodiments, the bridge sealing member **758** may comprise a substantially liquid impermeable film. Further, in some embodiments, the bridge sealing member **758** may comprise a vapor permeable film. Further, in some embodiments, the bridge sealing member **758** may comprise a breathable film. Additional examples of materials suitable for the bridge sealing member **758** may include, without limitation, a polyurethane (PU) drape or film such as Scapa Bioflex 130 polyurethane Film®; films formed from polymers, such as polyester and co-polyester; polyamide; polyamide/block polyether; acrylics; vinyl esters; polyvinyl alcohol copolymers; films with and without adhesive; and high Moisture Vapor Transfer Rate (MVTR) films, such as, for example, an INSPIRE 2305 polyurethane drape. High MVTR films may provide for evaporation of condensate, which may occur around the entire exterior surface of the bridge **720**. In this manner, capacity, fluid handling, and evaporative properties of the bridge **720** may be enhanced or improved due at least to increased surface area and air movement provided around all sides and portions of the exterior surface of the bridge **720**.

The bridge sealing member **758** may comprise a non-woven material or structure such as, without limitation, a polyester, co-polyester, polyolefin, cellulosic fiber, and combinations or blends of the foregoing materials. In some embodiments, the bridge sealing member **758** may comprise LIBELTEX TDL4 or LIBELTEX TDL2, or any of the materials recited above for the first dressing wicking layer **176** and the second dressing wicking layer **180**. Further, in some embodiments, the bridge sealing member **758** may comprise laminations with fiber or foam structures.

In some embodiments, the bridge sealing member **758** may include the first sealing layer **788** and the second sealing layer **790**. A first periphery or edge of the first sealing layer **788** may be coupled to a second periphery or edge of the second sealing layer **790** around the bridge envelope **750** in any suitable manner, such as, for example, by a weld **792** for forming the bridge sealing member **758** and encapsulating the bridge envelope **750** therein. In other embodiments, the bridge sealing member **758** may be formed from a single layer of material.

In operation, the reduced-pressure source **128** may be fluidly coupled to the receiving end **734** of the bridge **720**. For example, the conduit interface **148** may be fluidly coupled to the receiving end **734**, and the conduit **196** may be fluidly coupled between the conduit interface **148** and the reduced-pressure source **128** analogous to the previously described embodiments. The transmitting end **738** of the bridge **720** may be fluidly coupled to the dressing **124** as described herein. The reduced-pressure source **128** may be

activated to provide reduced pressure to the dressing 124 through the bridge 720, which may draw, wick, or pull fluids from the tissue site 104 and the dressing 124 into the bridge 720.

As fluid enters the bridge 720 through the transmitting end 738, the fluid may communicate through the internal passageway 784 and contact the fluid acquisition surface 772 of the first wicking layer 780. The fluid acquisition surface 772 of the first wicking layer 780 may receive the fluid so that the fluid may be transported through the first wicking layer 780. Subsequently, the fluid distribution surface 774 of the first wicking layer 780 may transmit the fluid from the first wicking layer 780. In some embodiments, the fluid distribution surface 774 of the first wicking layer 780 may transmit the fluid directly to the receiving end 734. In some embodiments, the fluid distribution surface 774 of the first wicking layer 780 may transmit fluid into the internal volume 760. In some embodiments, the fluid distribution surface 774 of the first wicking layer 780 may transmit the fluid to the receiving end 734 through the internal volume 760. In some embodiments, the fluid distribution surface 774 of the first wicking layer 780 may transmit fluid to the fluid acquisition surface 772 of the second wicking layer 781.

As fluid is transmitted from the fluid distribution surface 774 of the first wicking layer 780, the fluid may contact the fluid acquisition surface 772 of the second wicking layer 781. The fluid acquisition surface 772 of the second wicking layer 781 may receive the fluid so that the fluid may be transported through the second wicking layer 781. Subsequently, the fluid distribution surface 774 of the second wicking layer 781 may transmit the fluid from the second wicking layer 781. In some embodiments, the fluid distribution surface 774 of the second wicking layer 781 may transmit the fluid directly to the receiving end 734. In some embodiments, the fluid distribution surface 774 of the second wicking layer 781 may transmit fluid into the internal volume 760. In some embodiments, the fluid distribution surface 774 of the second wicking layer 781 may transmit the fluid to the receiving end 734 through the internal volume 760. In some embodiments, the fluid distribution surface 774 of the second wicking layer 781 may transmit fluid to the fluid acquisition surface 772 of the third wicking layer 782.

As fluid is transmitted from the fluid distribution surface 774 of the second wicking layer 781, the fluid may contact the fluid acquisition surface 772 of the third wicking layer 782. The fluid acquisition surface 772 of the third wicking layer 782 may receive the fluid so that the fluid may be transported through the third wicking layer 782. Subsequently, the fluid distribution surface 774 of the third wicking layer 782 may transmit the fluid from the third wicking layer 782. In some embodiments, the fluid distribution surface 774 of the third wicking layer 782 may transmit the fluid directly to the receiving end 734.

Although the subject matter of this disclosure has been provided by way of example in the context of certain illustrative, non-limiting embodiments, various changes, substitutions, permutations, and alterations can be made without departing from the scope of this disclosure as defined by the appended claims. Any feature described in connection to any one embodiment may also be applicable to any other embodiment. For example, an absorbent layer, such as absorbent layer 184 discussed herein, may be included within the bridge assembly 710. As such, the benefits and advantages described above may relate to one embodiment or may relate to several embodiments. Further,

the steps of the methods described herein may be carried out in any suitable order, or simultaneously where appropriate.

It should be understood, that dressings as discussed herein may include only one or more wicking layers (i.e. a dressing without an absorbent layer) and that a bridge as discussed herein in fluid communication with such dressing may include only one or more wicking layers (i.e. a bridge without an absorbent layer). It should also be understood, that that dressings as discussed herein may include only one or more wicking layers (i.e. a dressing without an absorbent layer) and that a bridge as discussed herein in fluid communication with such dressing may include one or more wicking layers and an absorbent layer. In addition, it should be understood, that dressings as discussed herein may include one or more wicking layers and an absorbent layer and that a bridge as discussed herein in fluid communication with such dressing may include only one or more wicking layers (i.e. a bridge without an absorbent layer).

Among other benefits described above, the storage bridge 320 may reduce power consumption, leakage, and other challenges that may be associated with fluid head pressure caused by a static column of fluid that can reside in a conventional tube or similar structure providing fluid communication between a dressing and a reduced-pressure source. Further, a mass of fluid removed from a tissue site may be moved away from the surface of the tissue site. The storage bridge 320 may also provide a low-profile and conformable solution for providing fluid communication with a tissue site, which may enhance patient comfort.

In addition, a system with dressings and/or bridges with one or more wicking layers and without absorbents may provide a low profile dressing and bridge so that a patient may discretely wear such a system, for example, by securing it to a tissue site with one or more bandages. In addition, a system with dressings and/or bridges with one or more wicking layers and without absorbents may be used with a manual pump or hand pump to remove fluid from a tissue site due to having relatively less air taken to be taken up by a canister of or in fluid communication with the manual pump or hand pump. This may be due at least in part to the low profile created by the one or more wicking layers. Further, a system with dressings and/or bridges with one or more wicking layers and without absorbents may have relatively less head pressure when reduced pressure is applied by a manual pump or hand pump. A system with dressings and/or bridges with one or more wicking layers and without absorbents may also extend the life of the system and increase mobility by a patient.

What is claimed is:

1. A bridge assembly for treating a tissue site, the bridge assembly comprising:

a bridge comprising a receiving end and a transmitting end separated by a length, the bridge further comprising:

a bridge sealing member extending along the length of the bridge and defining an internal passageway in fluid communication between the receiving end and the transmitting end; and

one or more bridge wicking layers disposed within the internal passageway, the one or more bridge wicking layers configured to communicate fluid between the receiving end and the transmitting end of the bridge, wherein the one or more bridge wicking layers comprise a first bridge wicking layer and a second bridge wicking layer, wherein the first bridge wicking layer has a surface area that is greater than a surface area of the second bridge wicking layer, and

47

wherein the first bridge wicking layer is adapted to be positioned underneath the second bridge wicking layer.

2. The bridge assembly of claim 1, further comprising a bridge absorbent disposed within the internal passageway, the bridge absorbent comprising a volume that is less than a volume of the internal passageway.

3. The bridge assembly of claim 1, further comprising a conduit interface adapted to be fluidly coupled to the receiving end of the bridge, the conduit interface in fluid communication with the transmitting end through the bridge.

4. The bridge assembly of claim 1, wherein the first bridge wicking layer has a density that is greater than a density of the second bridge wicking layer.

5. The bridge assembly of claim 1, wherein the bridge sealing member entirely surrounds the one or more bridge wicking layers.

6. The bridge assembly of claim 1, wherein the bridge sealing member encapsulates the one or more bridge wicking layers.

7. The bridge assembly of claim 1, wherein the bridge sealing member comprises a non-woven material.

8. The bridge assembly of claim 1, wherein the one or more bridge wicking layers is moveable within the internal passageway.

9. The bridge assembly of claim 1, wherein the one or more bridge wicking layers further comprises a third bridge wicking layer, and wherein a periphery of the first bridge wicking layer is coupled to a periphery of the third bridge wicking layer, and wherein the second bridge wicking layer is positioned between the first bridge wicking layer and the third bridge wicking layer.

10. The bridge assembly of claim 1, wherein each of the one or more bridge wicking layers is comprised of a non-woven material.

11. The bridge assembly of claim 1, wherein each of the one or more bridge wicking layers comprises a fluid acquisition surface and a fluid distribution surface positioned opposite the fluid acquisition surface, wherein the fluid distribution surface of each of the one or more bridge wicking layers faces a first direction, and wherein the fluid acquisition surface of each of the one or more bridge wicking layers faces a second direction.

12. The bridge assembly of claim 1, wherein the bridge sealing member comprises a substantially liquid impermeable film.

13. The bridge assembly of claim 1, wherein the bridge sealing member comprises a vapor permeable film.

14. The bridge assembly of claim 1, wherein the bridge sealing member comprises a breathable film.

15. The bridge assembly of claim 1, wherein the bridge sealing member comprises a first sealing layer and a second sealing layer, and wherein a periphery of the first sealing layer is coupled to a periphery of the second sealing layer around the one or more bridge wicking layers.

48

16. A bridge assembly for treating a tissue site, the bridge assembly comprising:

a bridge comprising a receiving end and a transmitting end separated by a length, the bridge further comprising:

a bridge sealing member extending along the length of the bridge and defining an internal passageway in fluid communication between the receiving end and the transmitting end; and

a first bridge wicking layer and a second bridge wicking layer disposed within the internal passageway and configured to communicate fluid between the receiving end and the transmitting end, wherein the first bridge wicking layer has a density that is greater than a density of the second bridge wicking layer, and wherein the first bridge wicking layer is adapted to be positioned underneath the second bridge wicking layer.

17. A bridge assembly for treating a tissue site, the bridge assembly comprising:

a bridge comprising a receiving end and a transmitting end separated by a length, the bridge further comprising:

a bridge sealing member extending along the length of the bridge and defining an internal passageway in fluid communication between the receiving end and the transmitting end; and

one or more bridge wicking layers disposed within the internal passageway and configured to communicate fluid between the receiving end and the transmitting end, wherein a periphery of one of the one or more bridge wicking layers is directly coupled to a periphery of another of the one or more bridge wicking layers to form an enclosure therebetween.

18. A bridge assembly for treating a tissue site, the bridge assembly comprising:

a bridge comprising a receiving end and a transmitting end separated by a length, the bridge further comprising:

a bridge sealing member extending along the length of the bridge and defining an internal passageway in fluid communication between the receiving end and the transmitting end; and

one or more bridge wicking layers disposed within the internal passageway, the one or more bridge wicking layers configured to communicate fluid between the receiving end and the transmitting end of the bridge, wherein the one or more bridge wicking layers comprises a first bridge wicking layer, a second bridge wicking layer, and a third bridge wicking layer, and wherein a periphery of the first bridge wicking layer is coupled to a periphery of the third bridge wicking layer, and wherein the second bridge wicking layer is positioned between the first bridge wicking layer and the third bridge wicking layer.

\* \* \* \* \*