



US011579573B2

(12) **United States Patent**
Petrus et al.

(10) **Patent No.:** **US 11,579,573 B2**
(45) **Date of Patent:** ***Feb. 14, 2023**

(54) **INTELLIGENT BUILDING MANAGEMENT SYSTEMS**

(71) Applicant: **SmithGroup, Inc.**, Detroit, MI (US)

(72) Inventors: **Ionel Petrus**, Silver Springs, MD (US); **YoonSun Rosemary Hwang**, Arlington, VA (US); **Kevin James Ricart**, Washington, DC (US); **Kevin Patrick Andreone**, Washington, DC (US); **Kristin Lea Maruszewski**, Washington, DC (US); **Jacob William Pohlman**, Washington, DC (US)

(73) Assignee: **SMITHGROUP, INC.**, Detroit, MI (US)

(*) Notice: Subject to any disclaimer, the term of this patent is extended or adjusted under 35 U.S.C. 154(b) by 76 days.

This patent is subject to a terminal disclaimer.

(21) Appl. No.: **17/163,133**

(22) Filed: **Jan. 29, 2021**

(65) **Prior Publication Data**

US 2021/0149350 A1 May 20, 2021

Related U.S. Application Data

(63) Continuation of application No. 16/436,564, filed on Jun. 10, 2019, now Pat. No. 10,908,564.

(Continued)

(51) **Int. Cl.**
G05B 13/04 (2006.01)
G05B 13/02 (2006.01)
G06N 20/00 (2019.01)

(52) **U.S. Cl.**
CPC **G05B 13/041** (2013.01); **G05B 13/0265** (2013.01); **G06N 20/00** (2019.01); **G05B 2219/25011** (2013.01)

(58) **Field of Classification Search**

CPC G05B 13/041
See application file for complete search history.

(56) **References Cited**

U.S. PATENT DOCUMENTS

8,091,088 B2 * 1/2012 Kishan G06F 9/50
718/104

9,092,741 B1 7/2015 Goparaju et al.

(Continued)

FOREIGN PATENT DOCUMENTS

WO 2013176334 A1 11/2013
WO WO-2013176334 A1 * 11/2013 G06Q 10/06

OTHER PUBLICATIONS

Jim Gao, "Machine Learning Applications for Data Center Optimization." Google, 2014, pp. 1-13.

Primary Examiner — Suresh Suryawanshi

(74) *Attorney, Agent, or Firm* — Brooks Kushman P.C.

(57) **ABSTRACT**

A hierarchical resource management system for a building includes one or more processors. The processors implement a plurality of agents that each monitor sensed values, and generate operating scenarios based on the sensed values for corresponding resources. The processors also implement a coordinator that filters the operating scenarios to remove the operating scenarios that violate internal laws of the agents to form an aggregate validated set of operating scenarios. The processors further implement a supervisor that, responsive to receipt of target conditions for the zones and the aggregate validated set of operating scenarios from the coordinator, selects a combination of the operating scenarios from the aggregate validated set of operating scenarios that achieves target conditions and minimizes overall energy consumption by the resources such that some of the operating scenarios of the combination do not minimize energy consumption of the resources corresponding to the some of the operating scenarios.

8 Claims, 23 Drawing Sheets

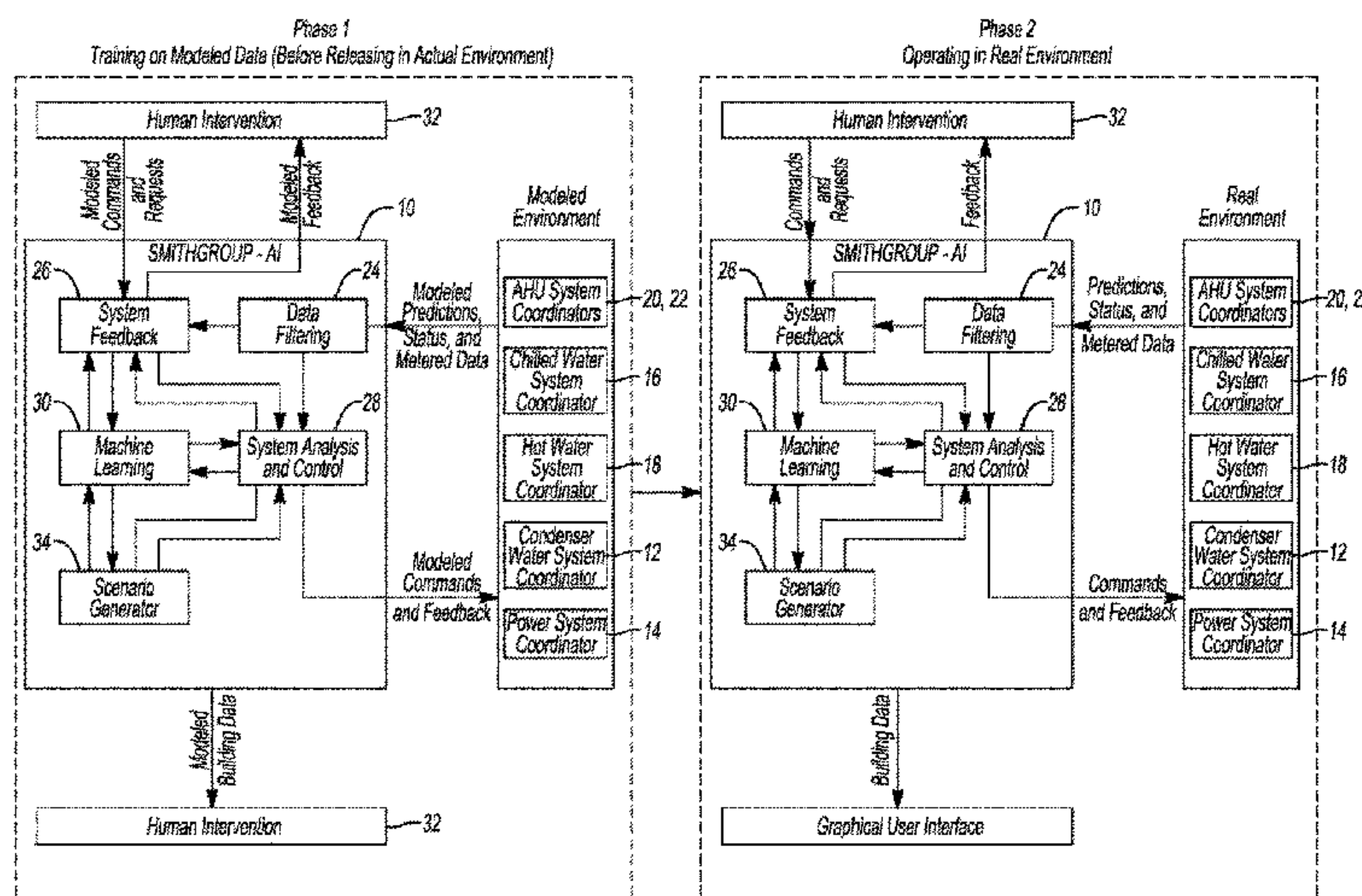

Related U.S. Application Data

(60) Provisional application No. 62/682,746, filed on Jun. 8, 2018.

(56) **References Cited**

U.S. PATENT DOCUMENTS

9,817,383	B1	11/2017	Sinha et al.	
2009/0276060	A1	11/2009	Lu et al.	
2012/0010757	A1*	1/2012	Francino	G05B 15/02 700/291
2017/0322534	A1	11/2017	Sinha et al.	
2018/0138742	A1	5/2018	Song et al.	
2018/0204116	A1	7/2018	Evans et al.	
2018/0275625	A1	9/2018	Park et al.	
2018/0299840	A1	10/2018	Sinha et al.	
2018/0335759	A1	11/2018	Harvey	
2018/0356775	A1	12/2018	Harvey	
2018/0364654	A1	12/2018	Locke et al.	
2019/0017719	A1	1/2019	Sinha et al.	
2019/0353379	A1	11/2019	Lee et al.	
2019/0361412	A1	11/2019	Park et al.	

* cited by examiner

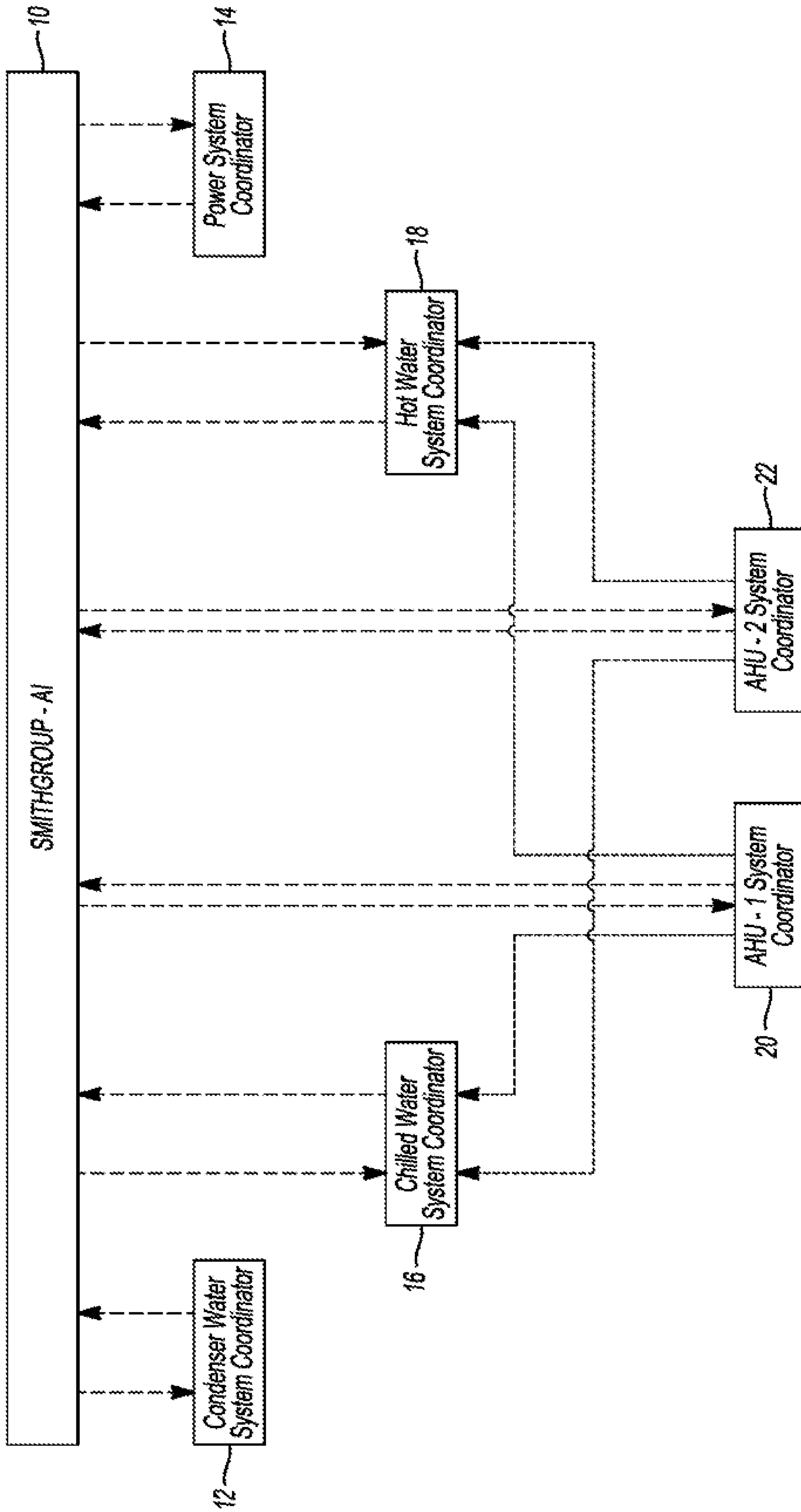

Fig-1

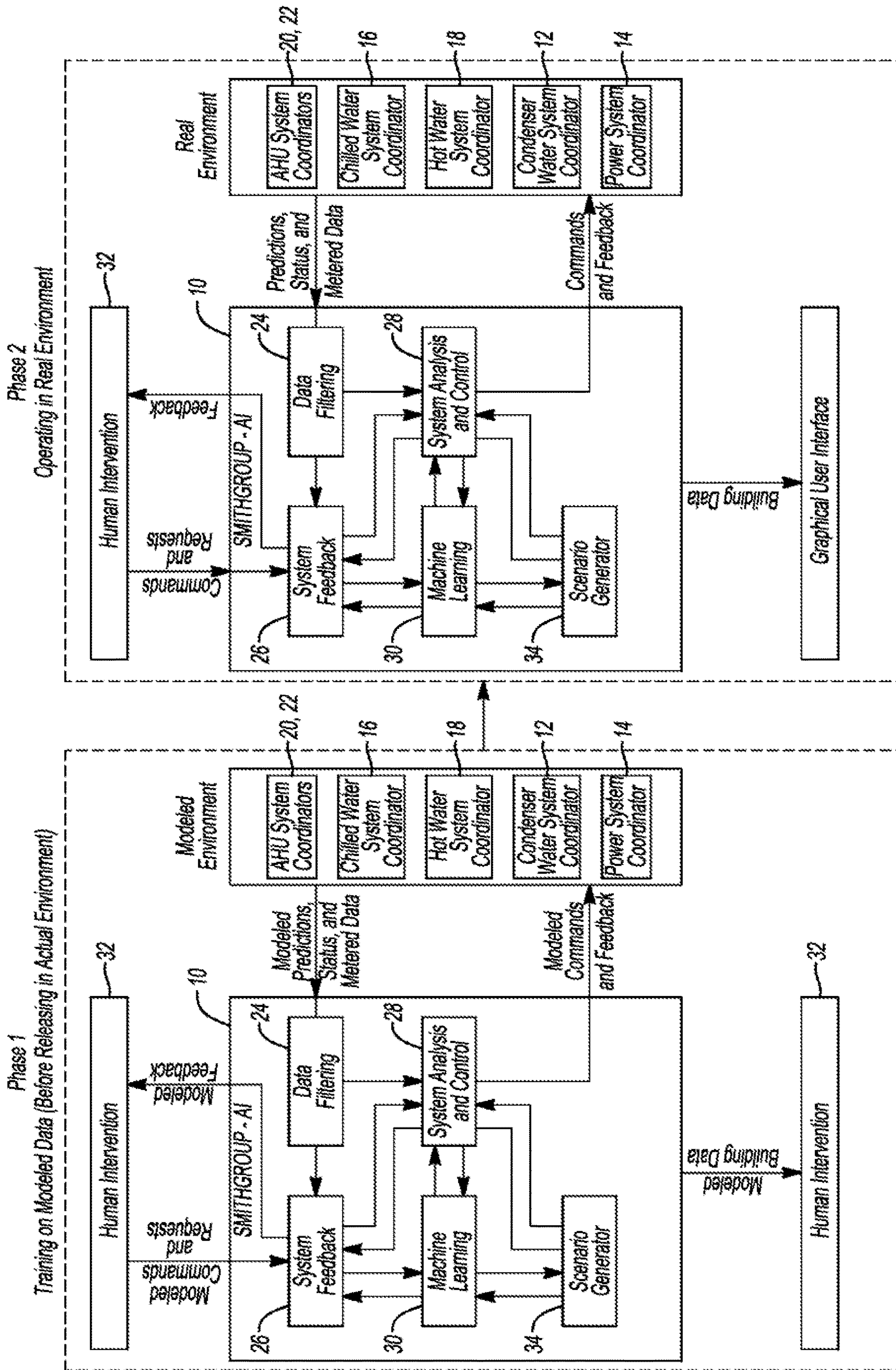

Fig-2

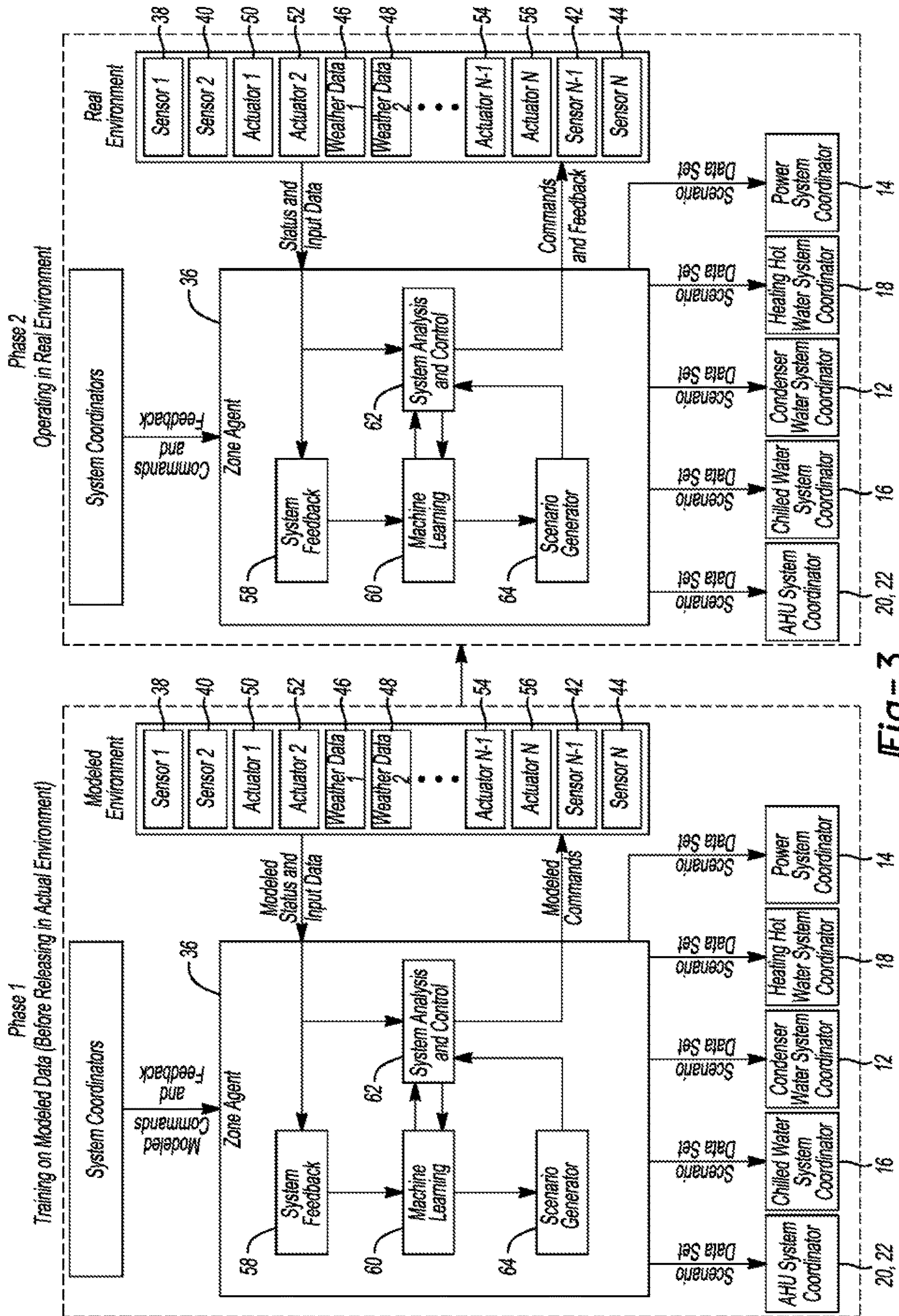

Fig-3

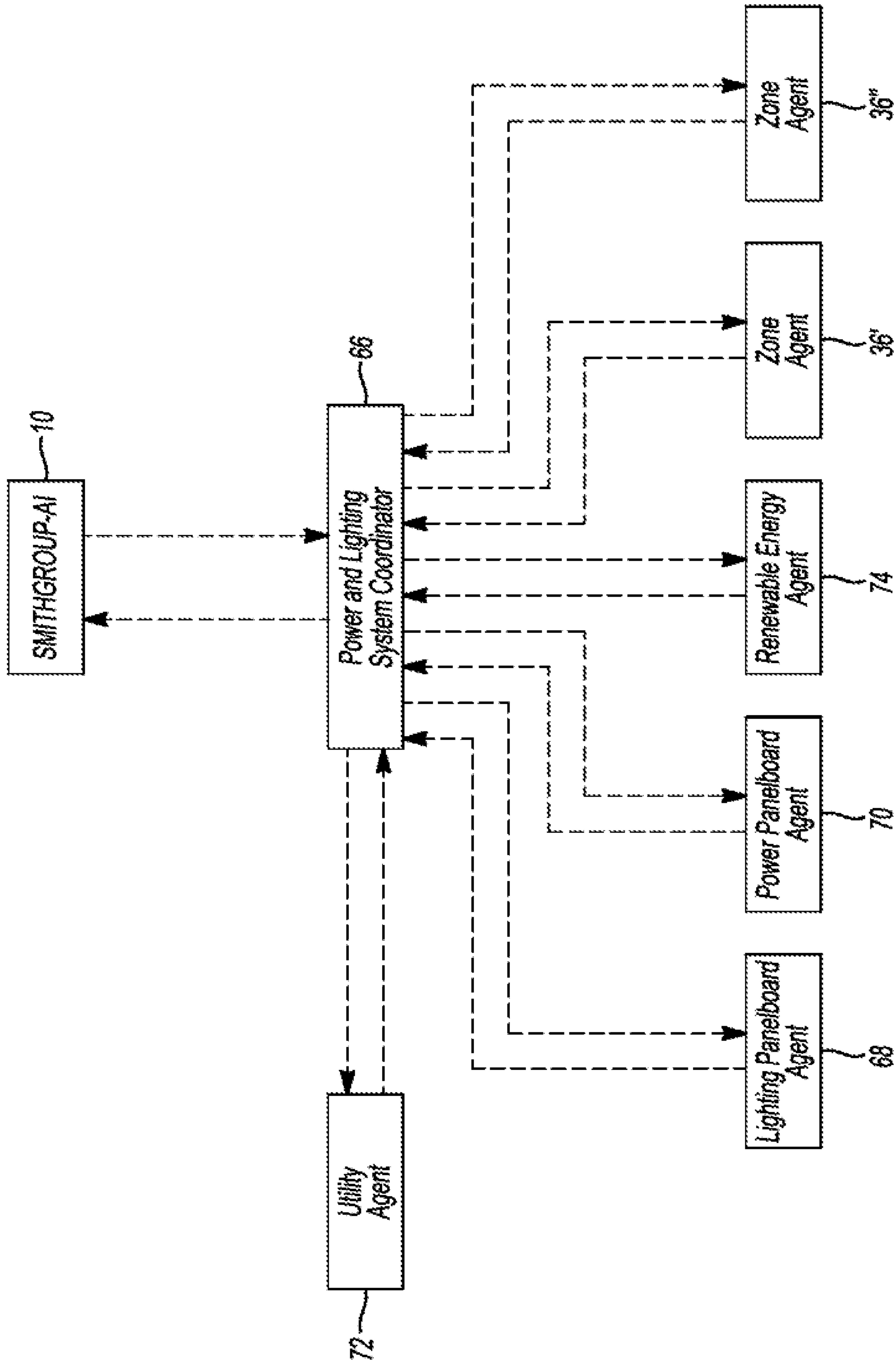

Fig-4

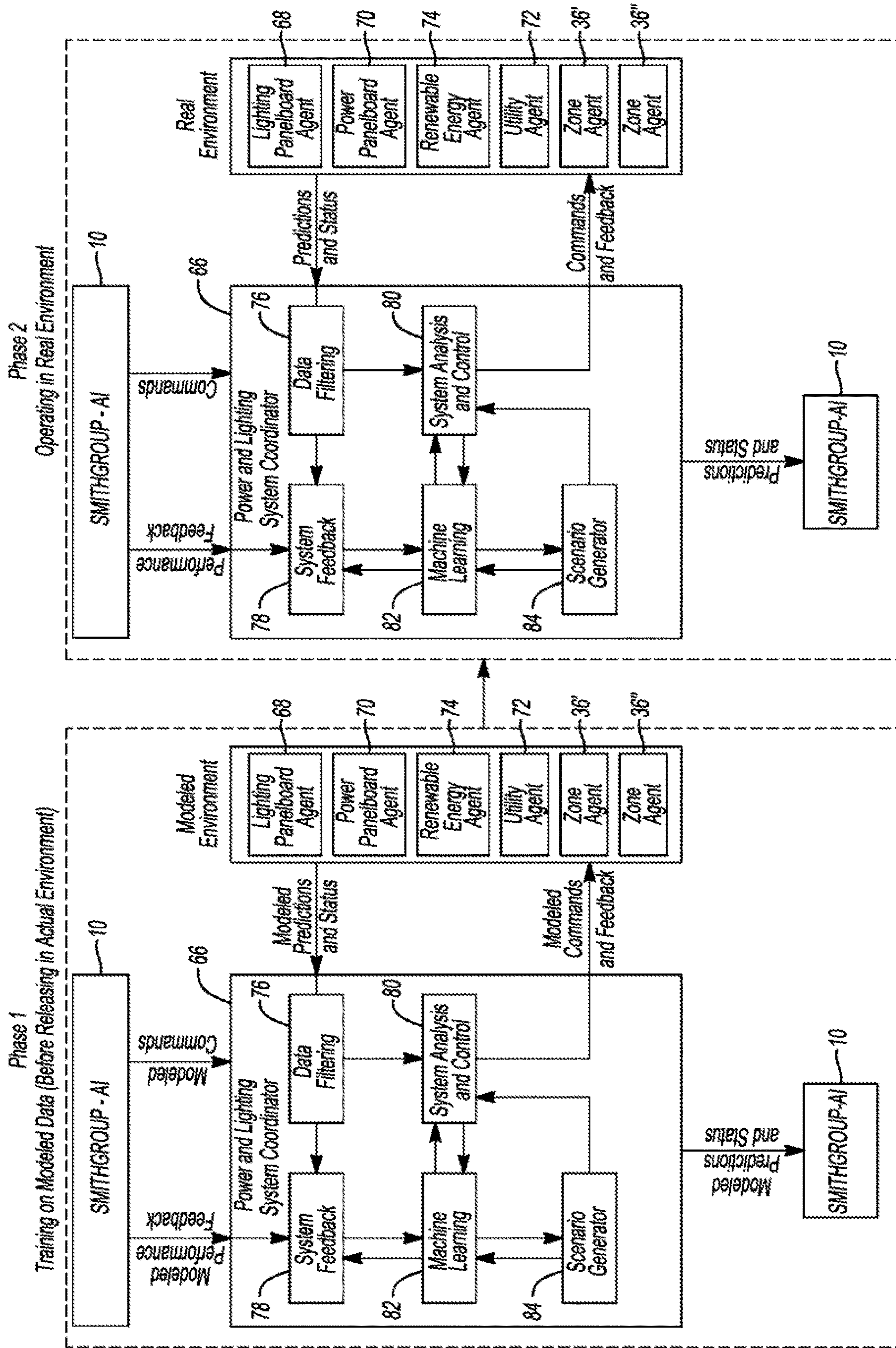

Fig-5

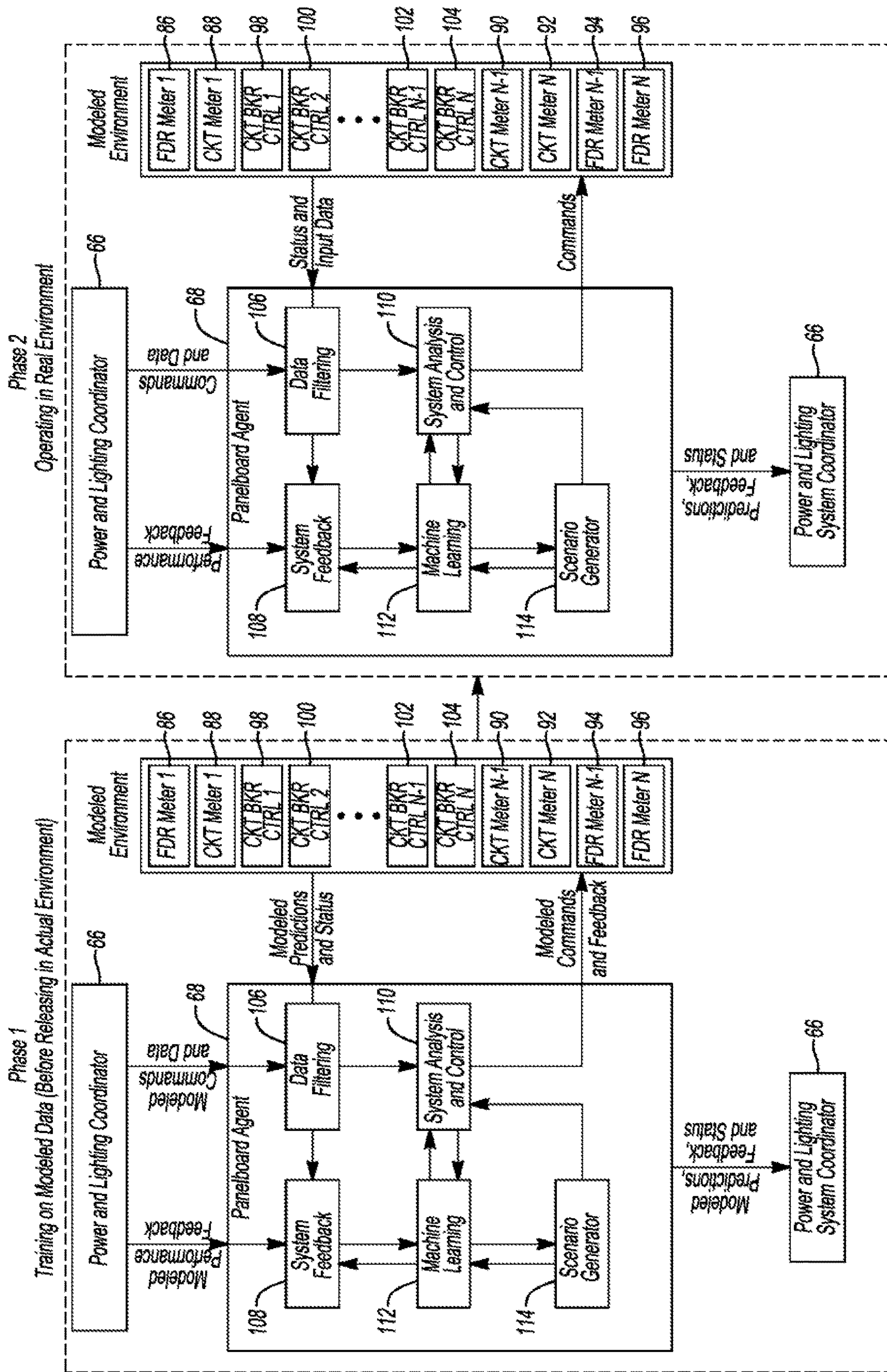

Fig-6

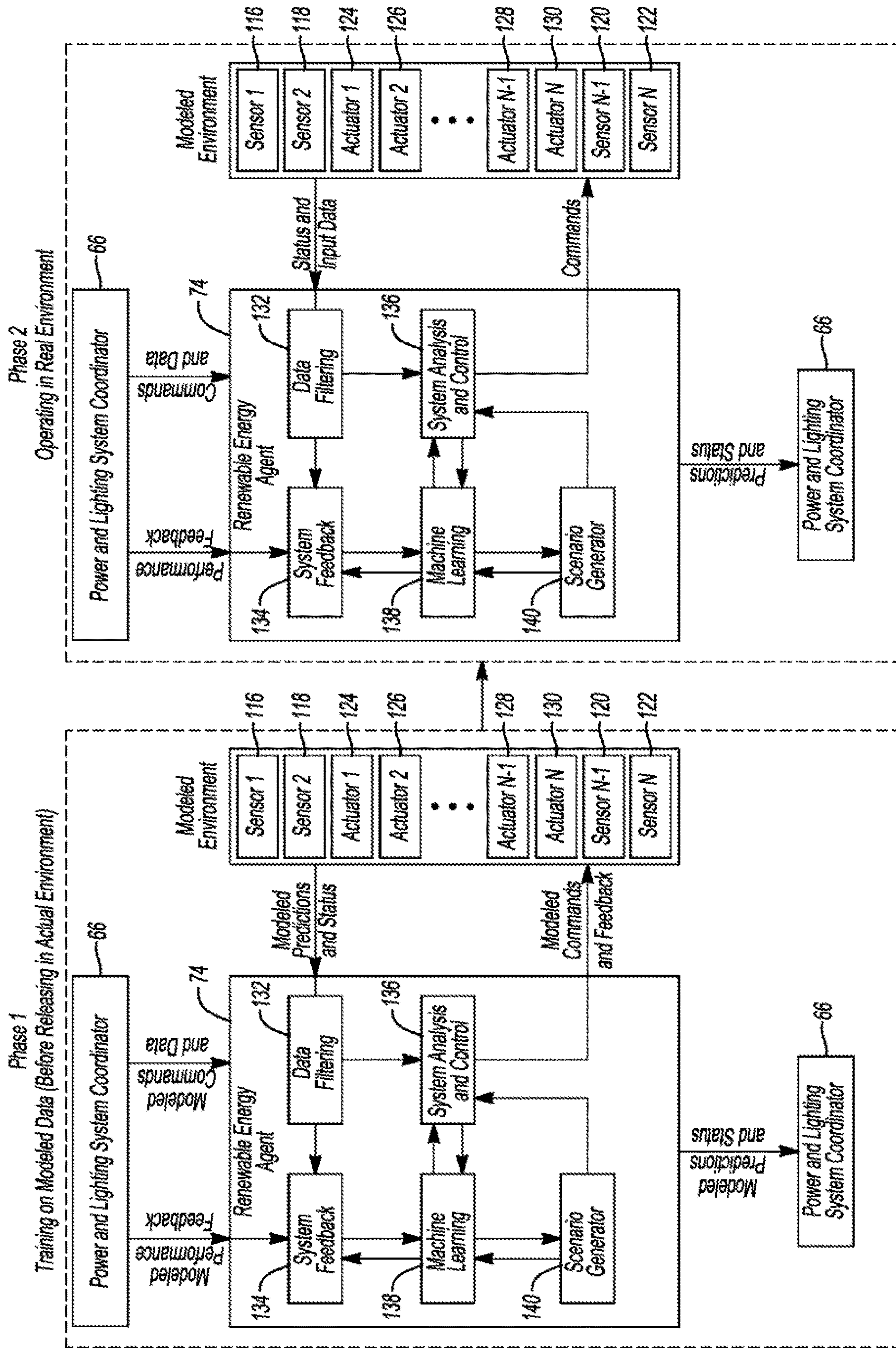

Fig-7

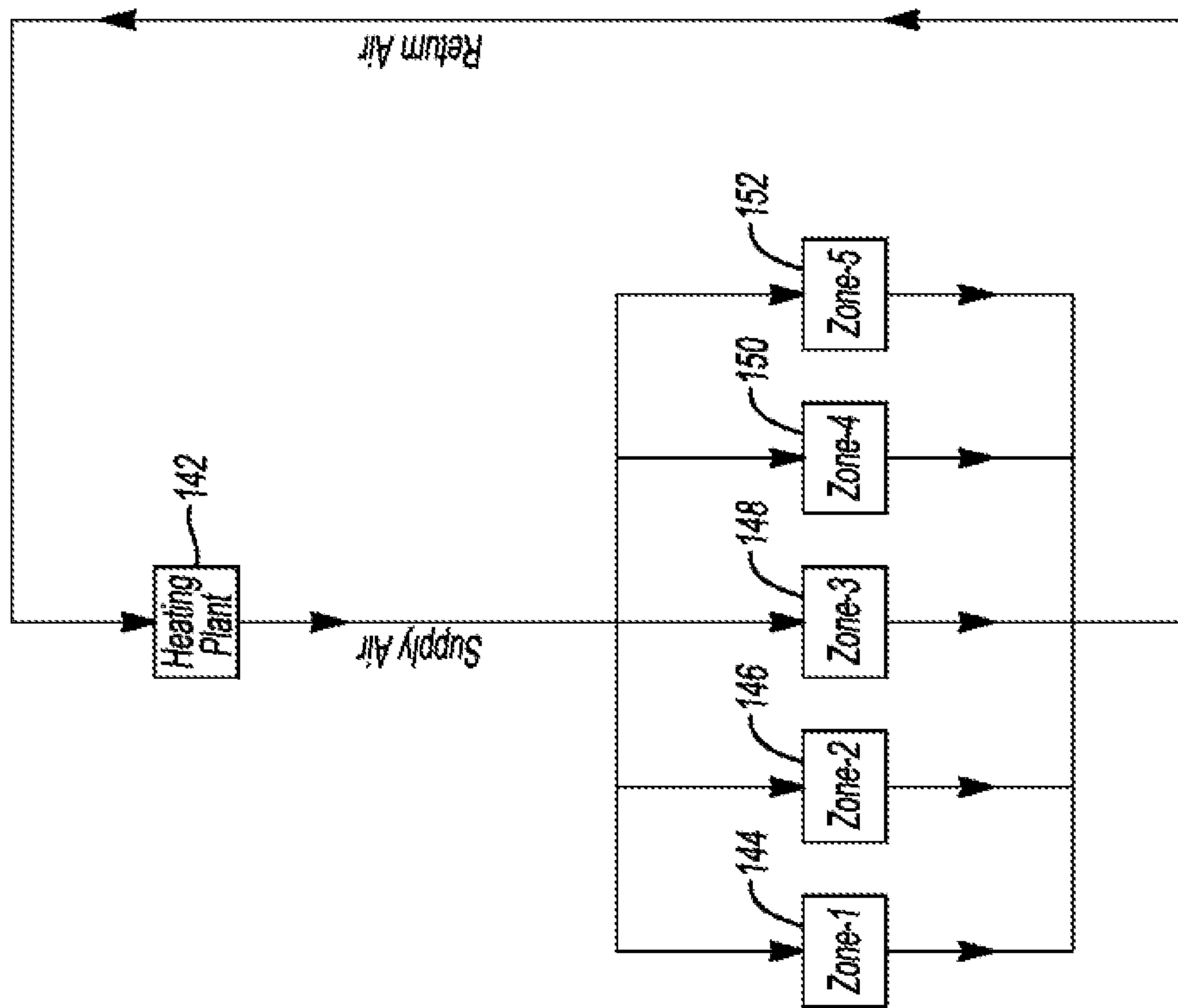

Fig-8

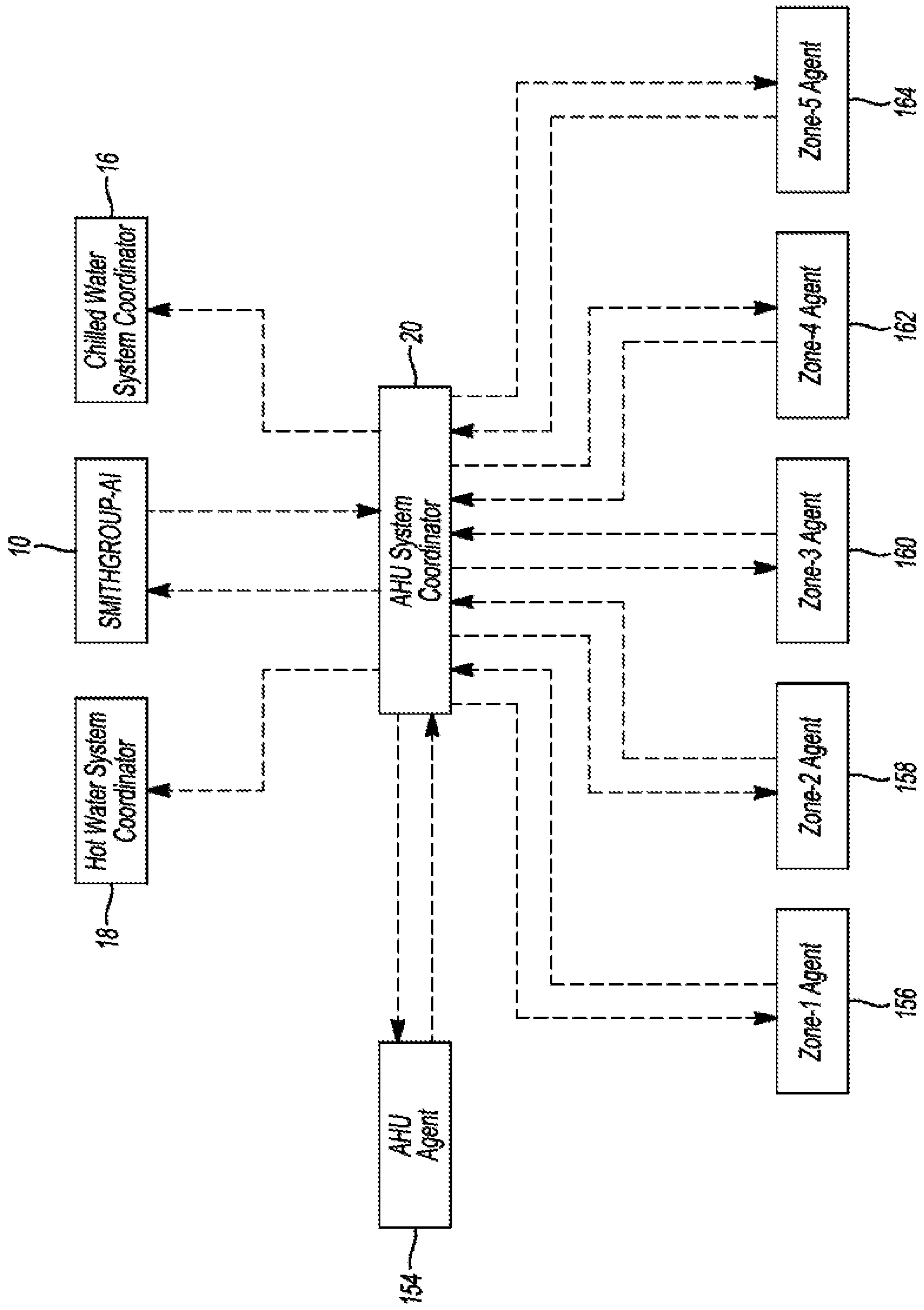

Fig-9

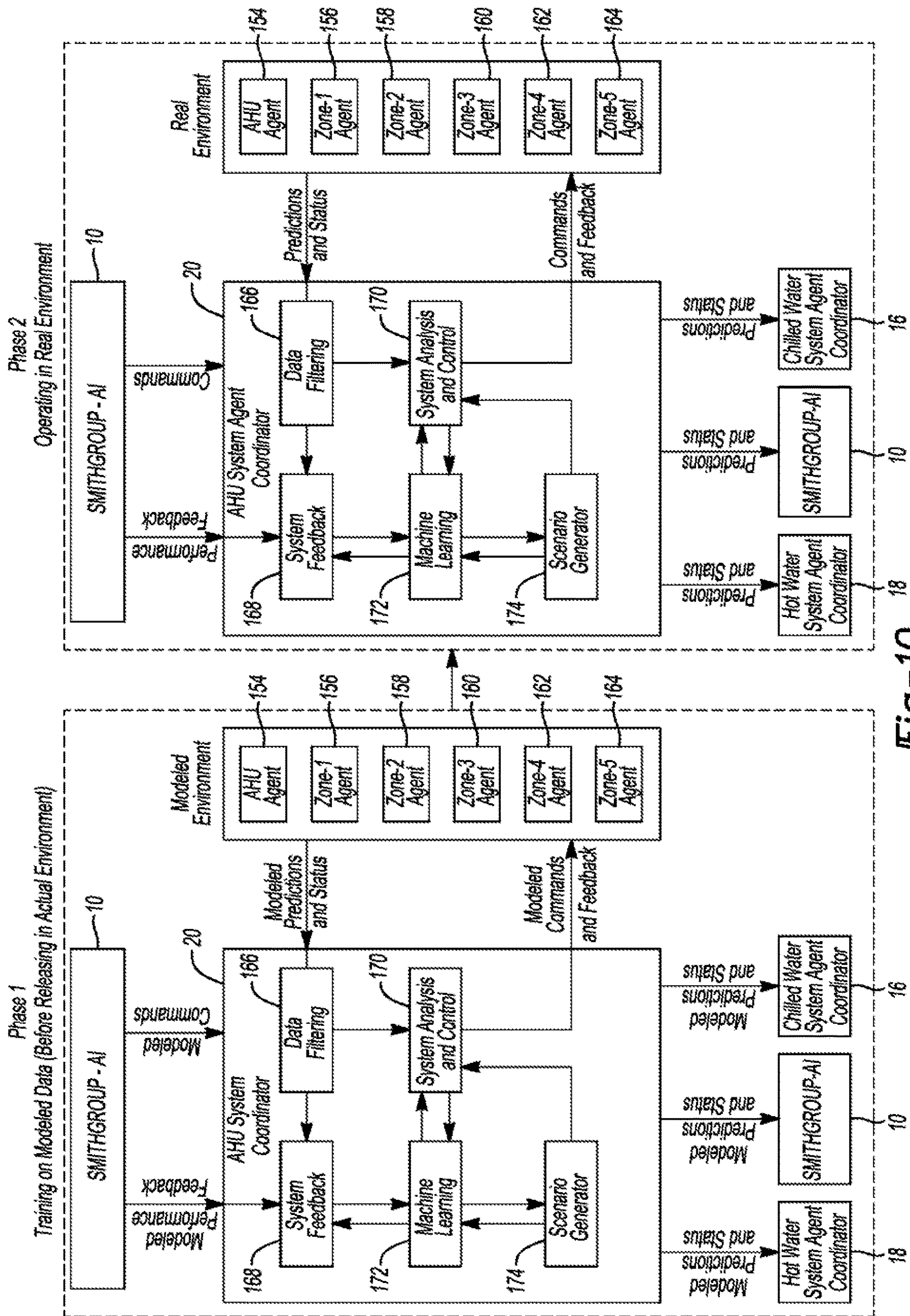

Fig-10

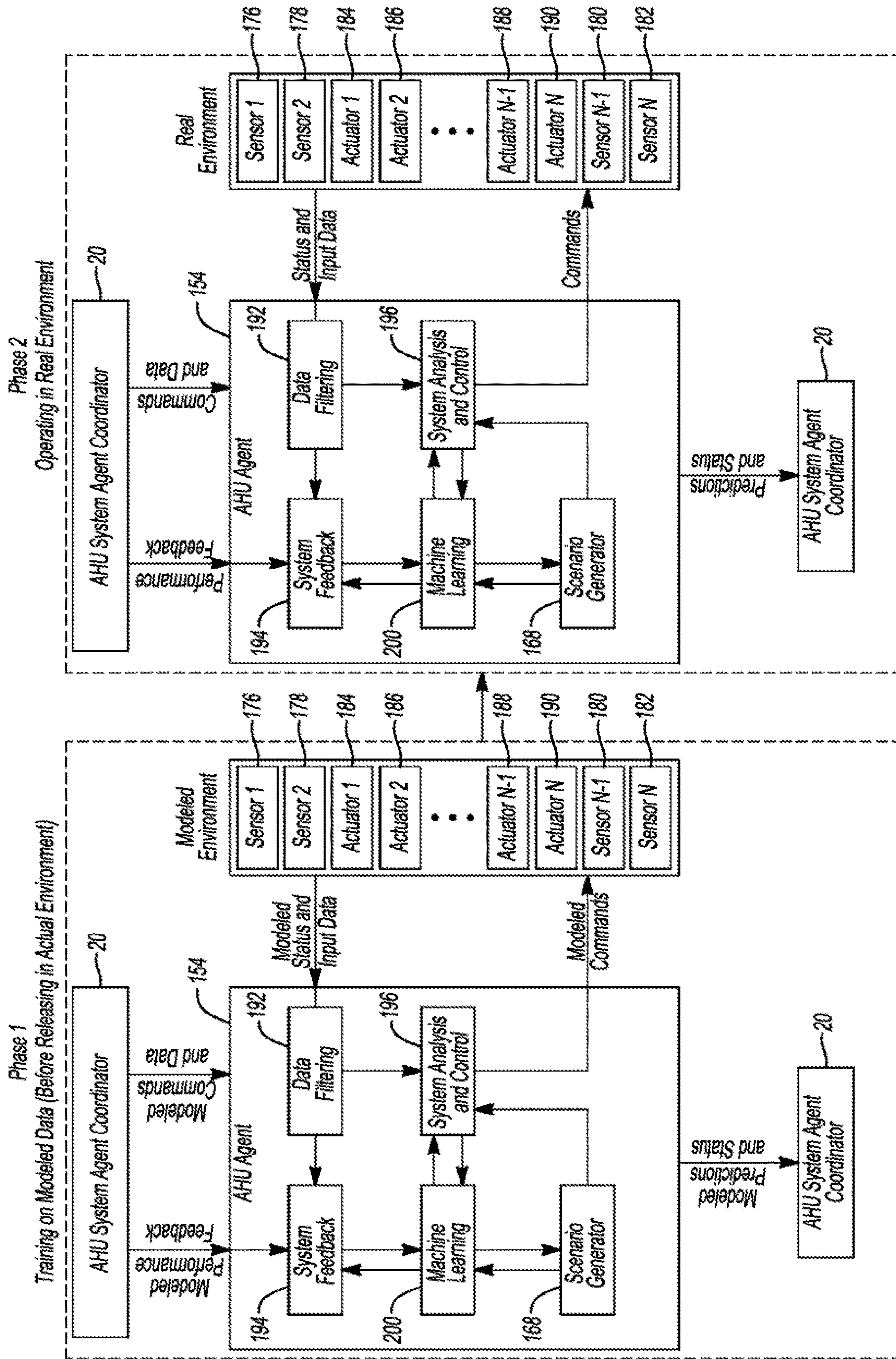

Fig-11

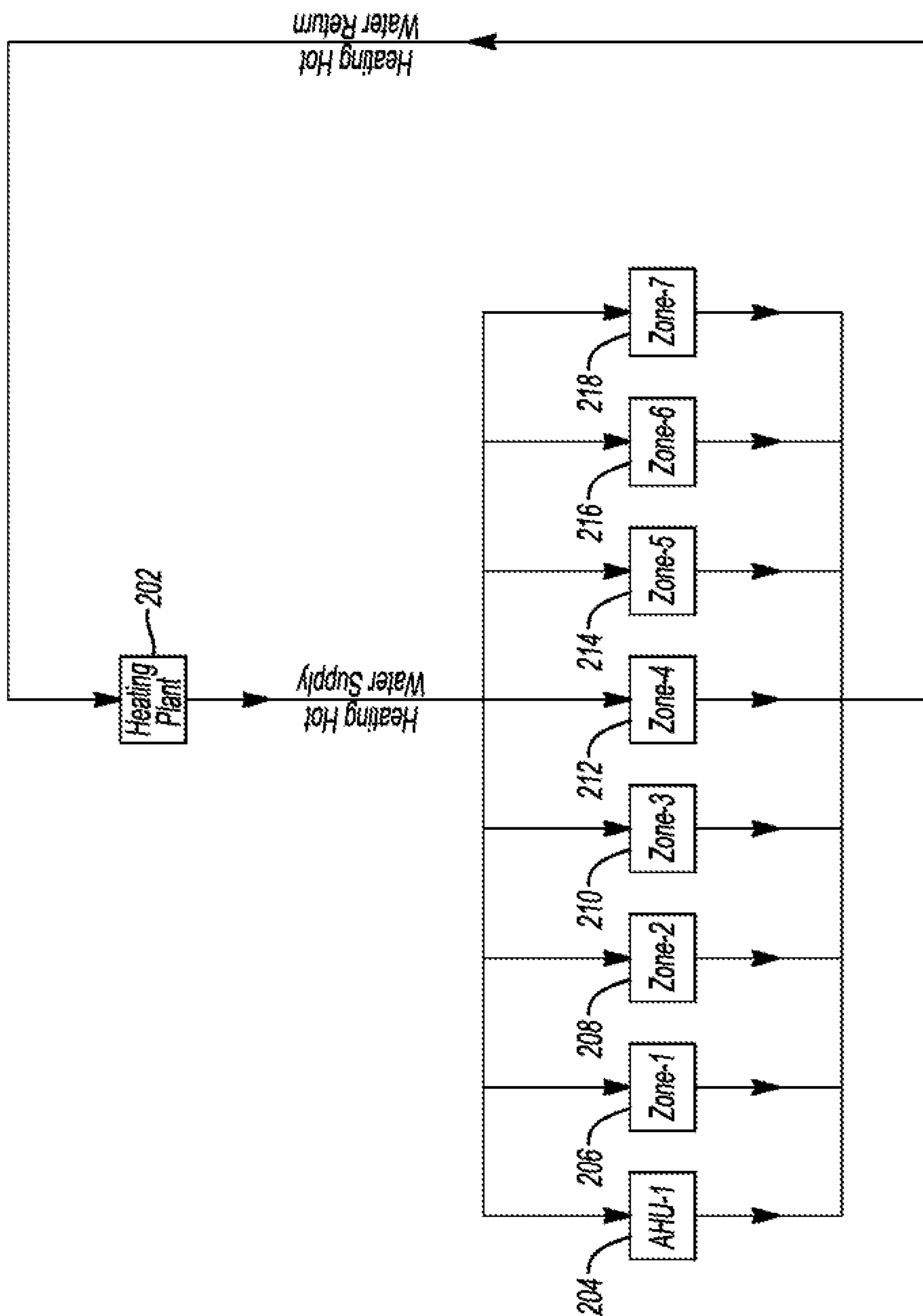

Fig-12

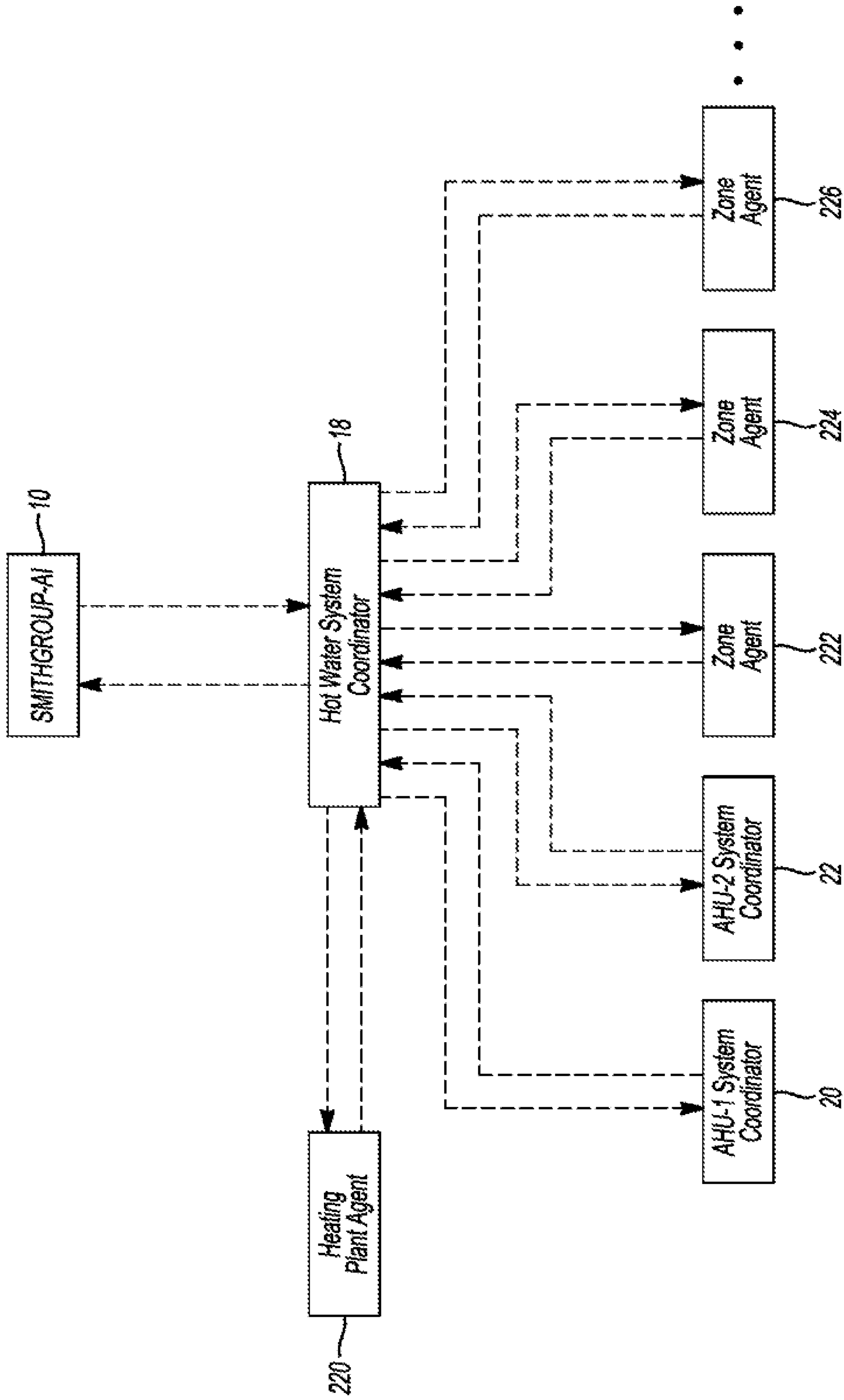

Fig-13

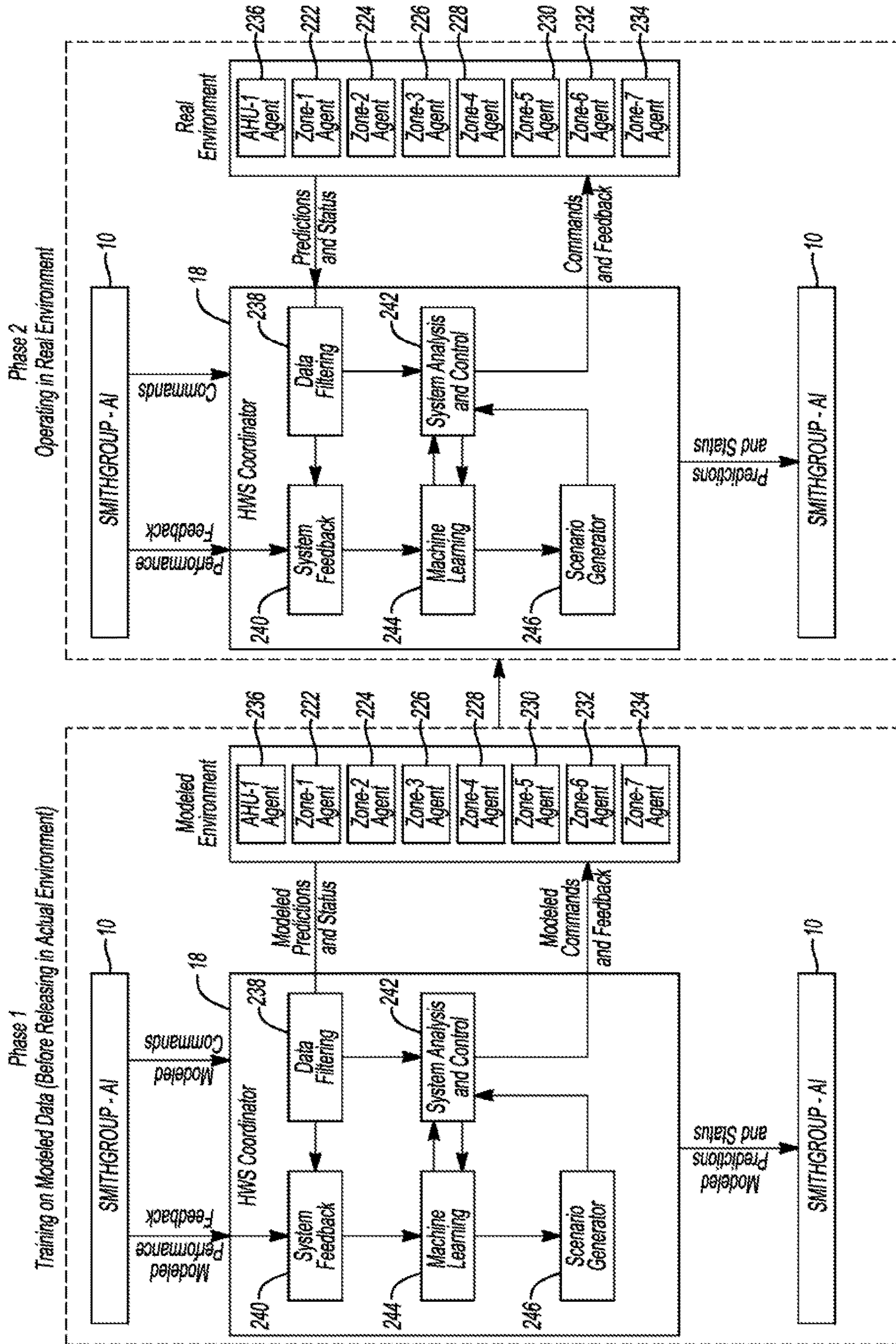

Fig-14

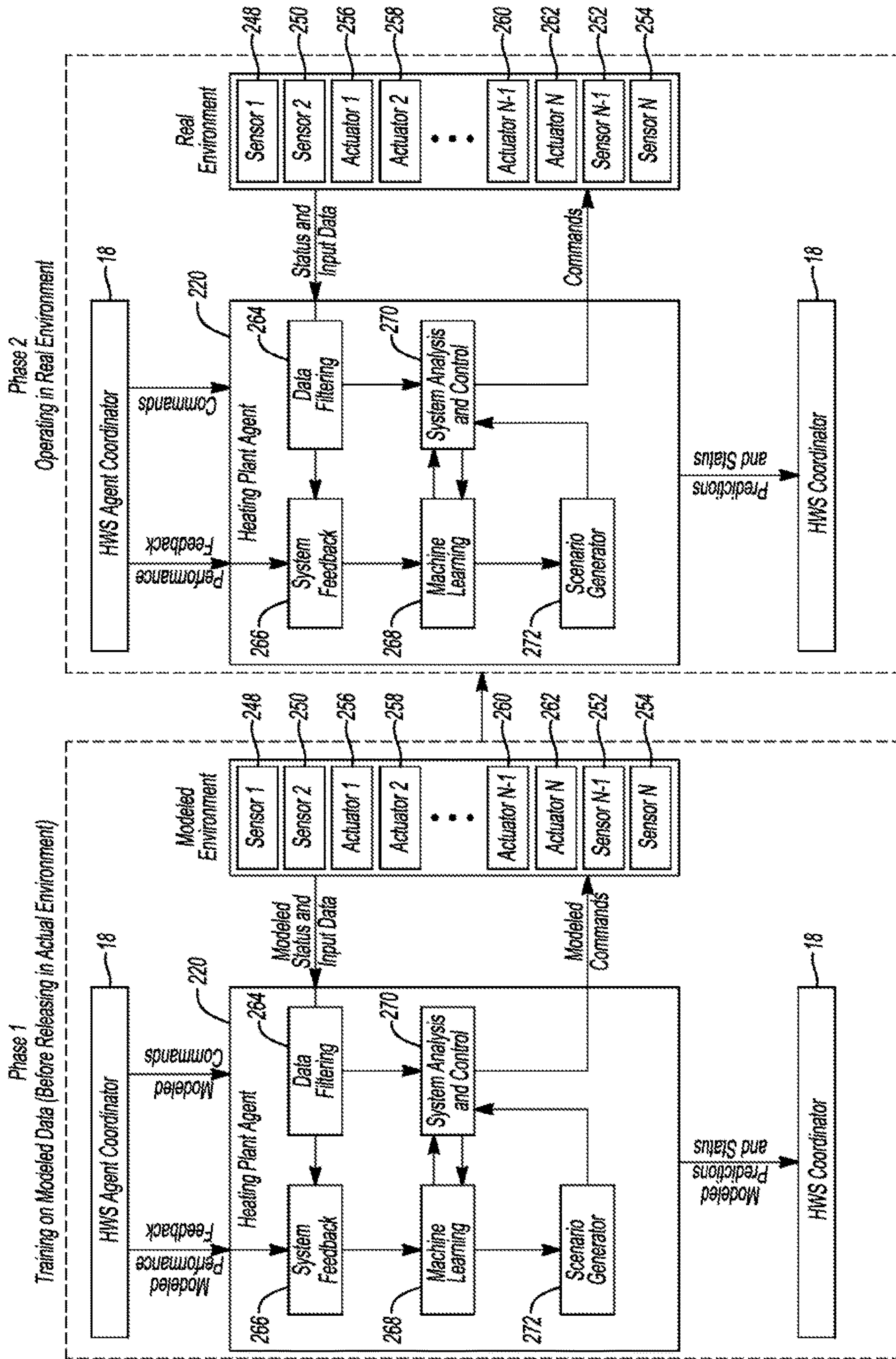

Fig-15

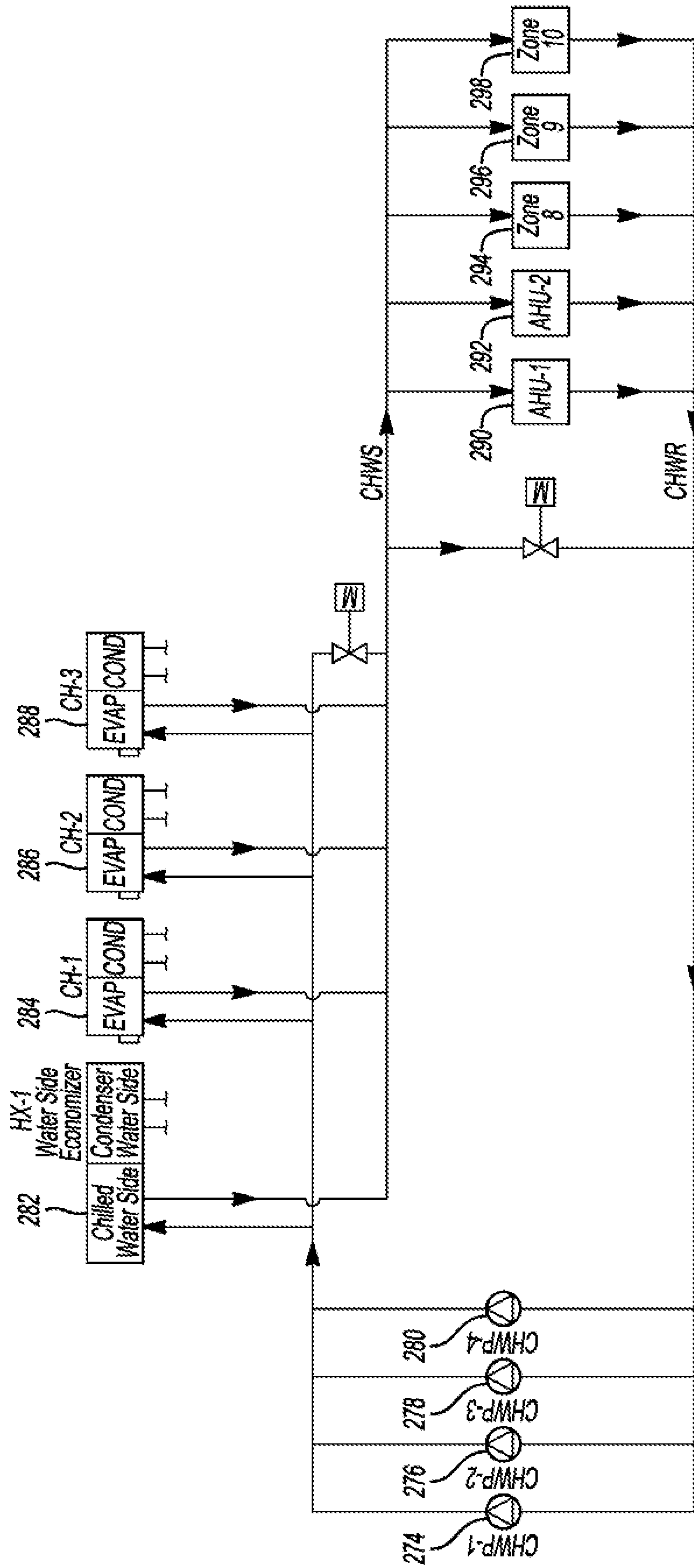

Fig-16

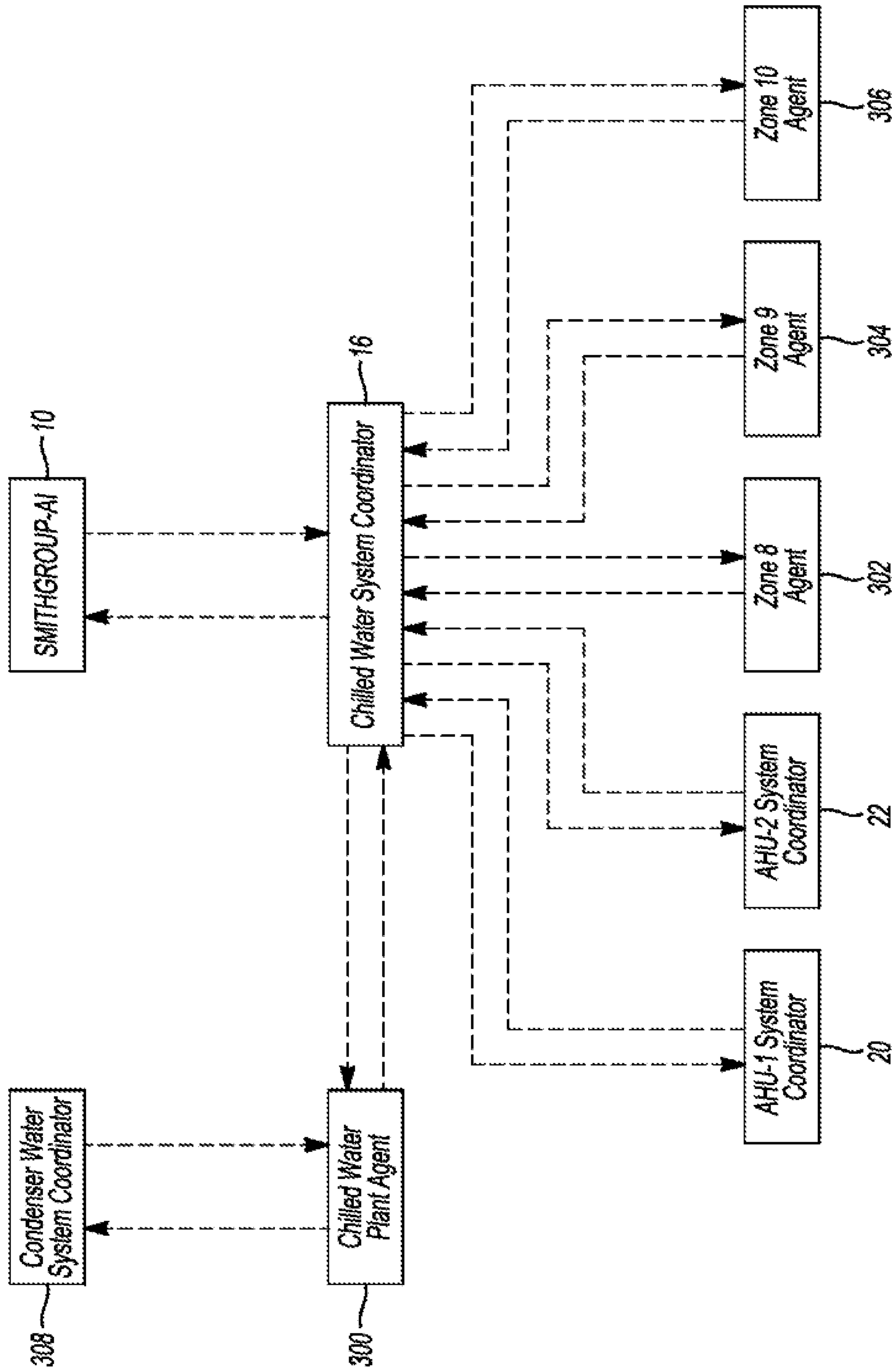

Fig-17

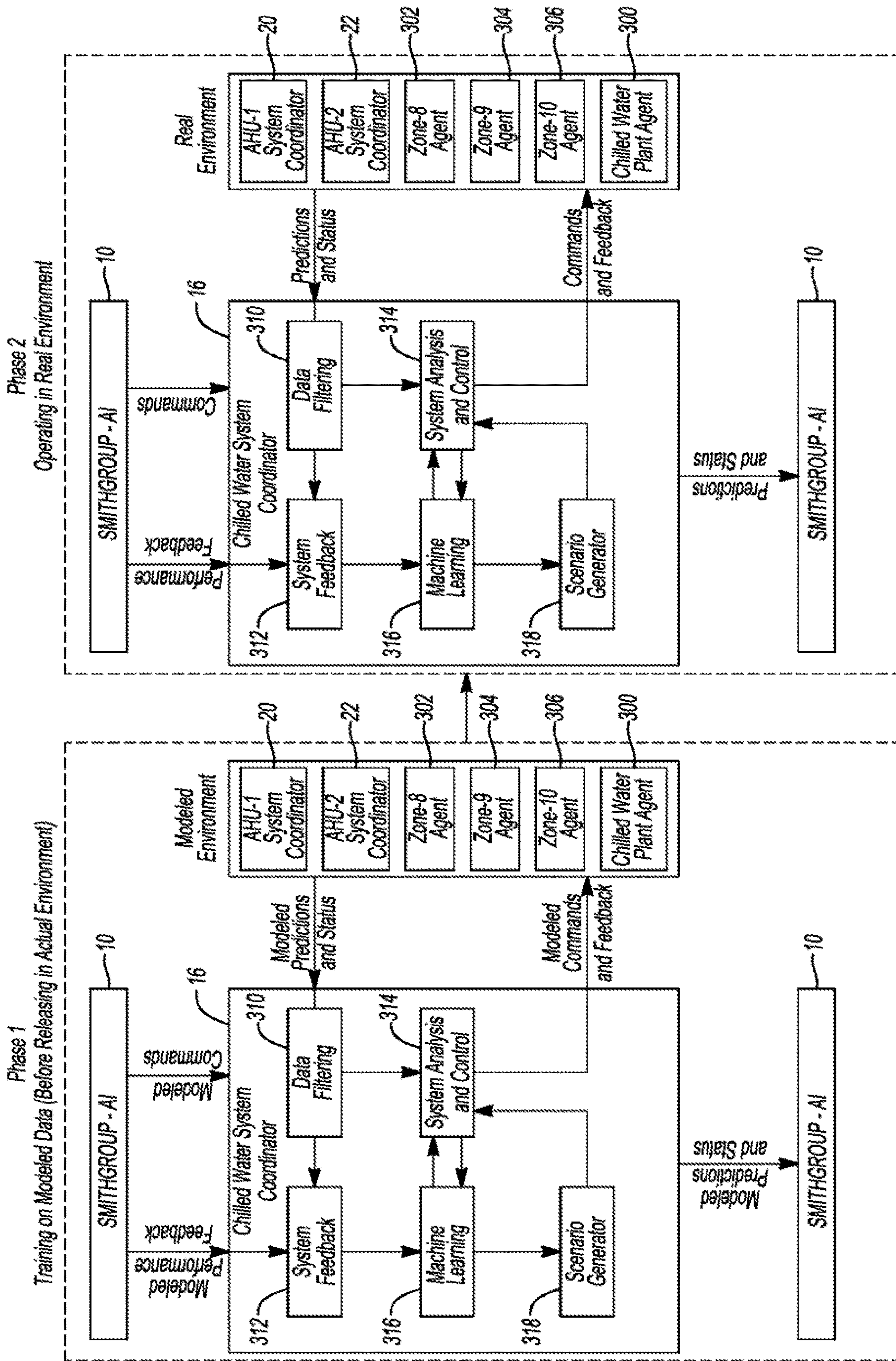

Fig-18

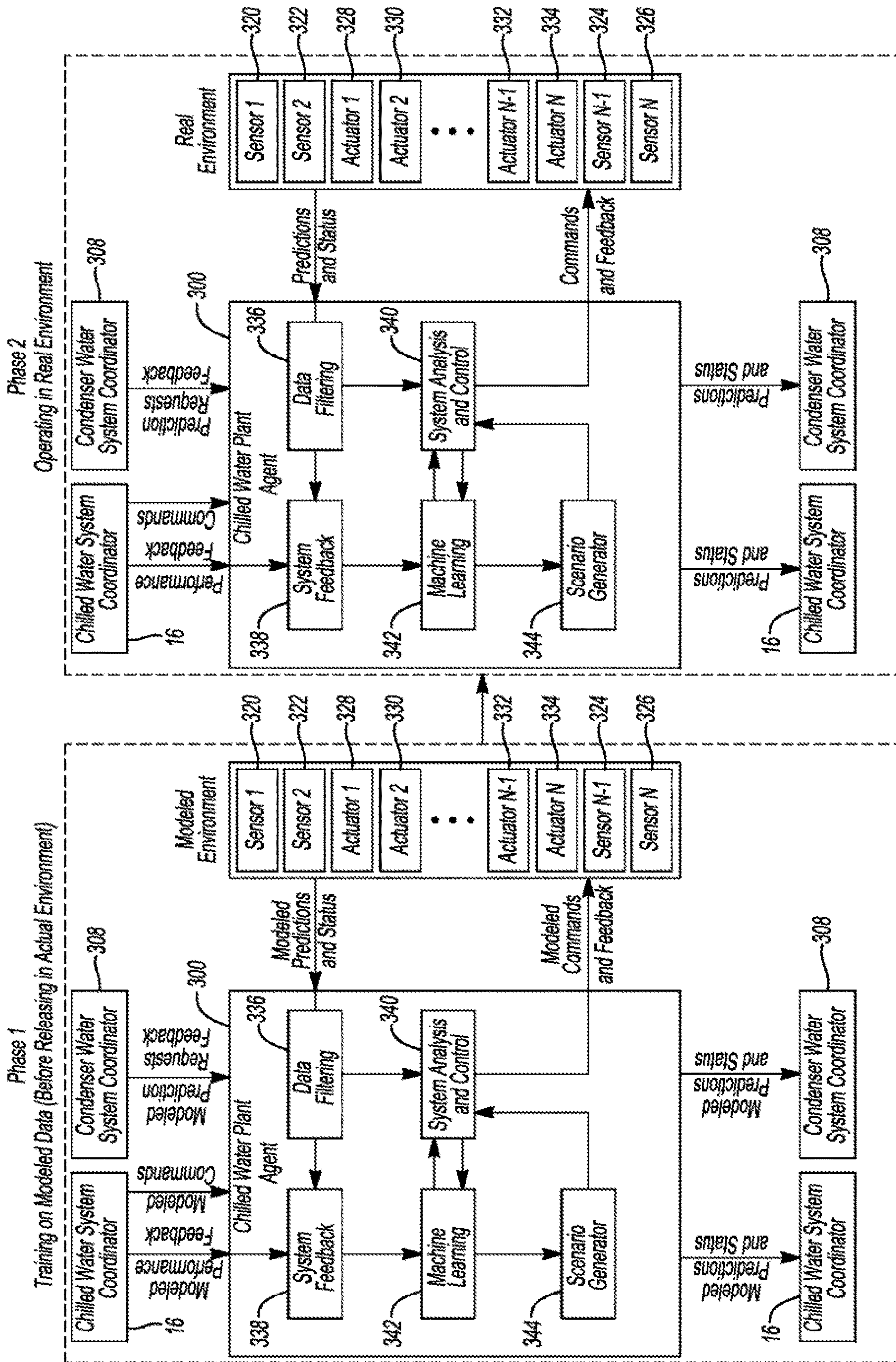

Fig-19

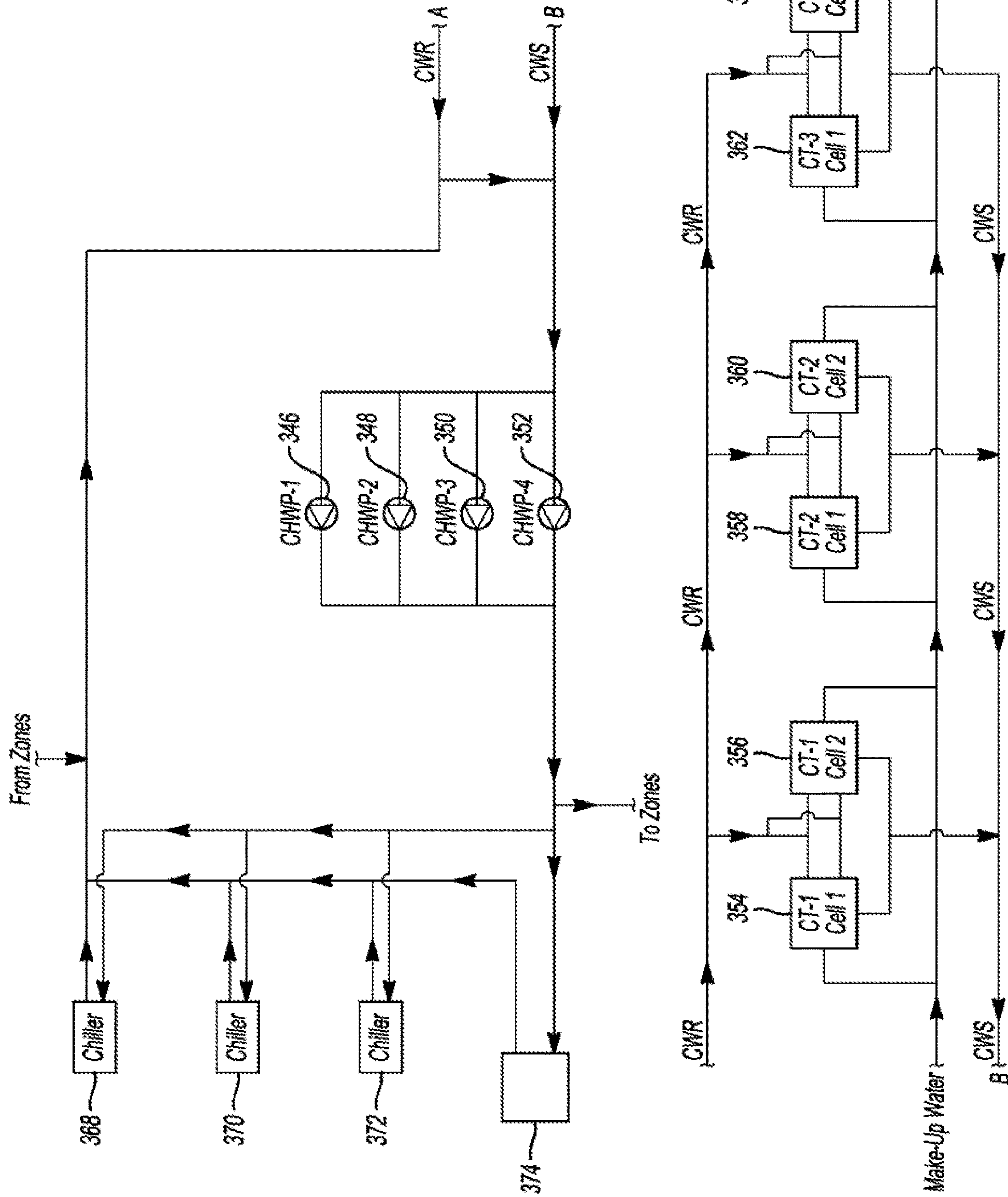

Fig-20

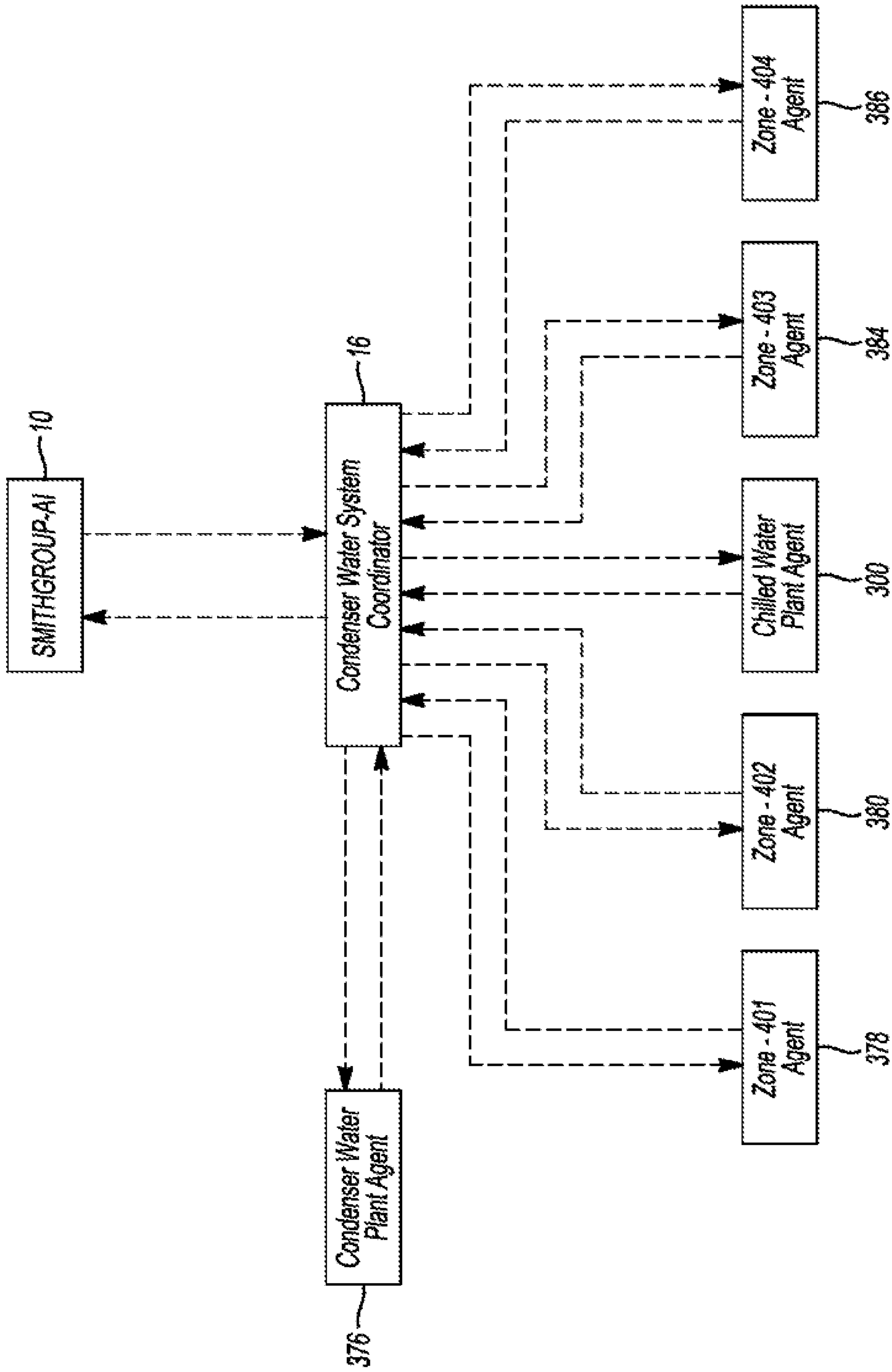

Fig-21

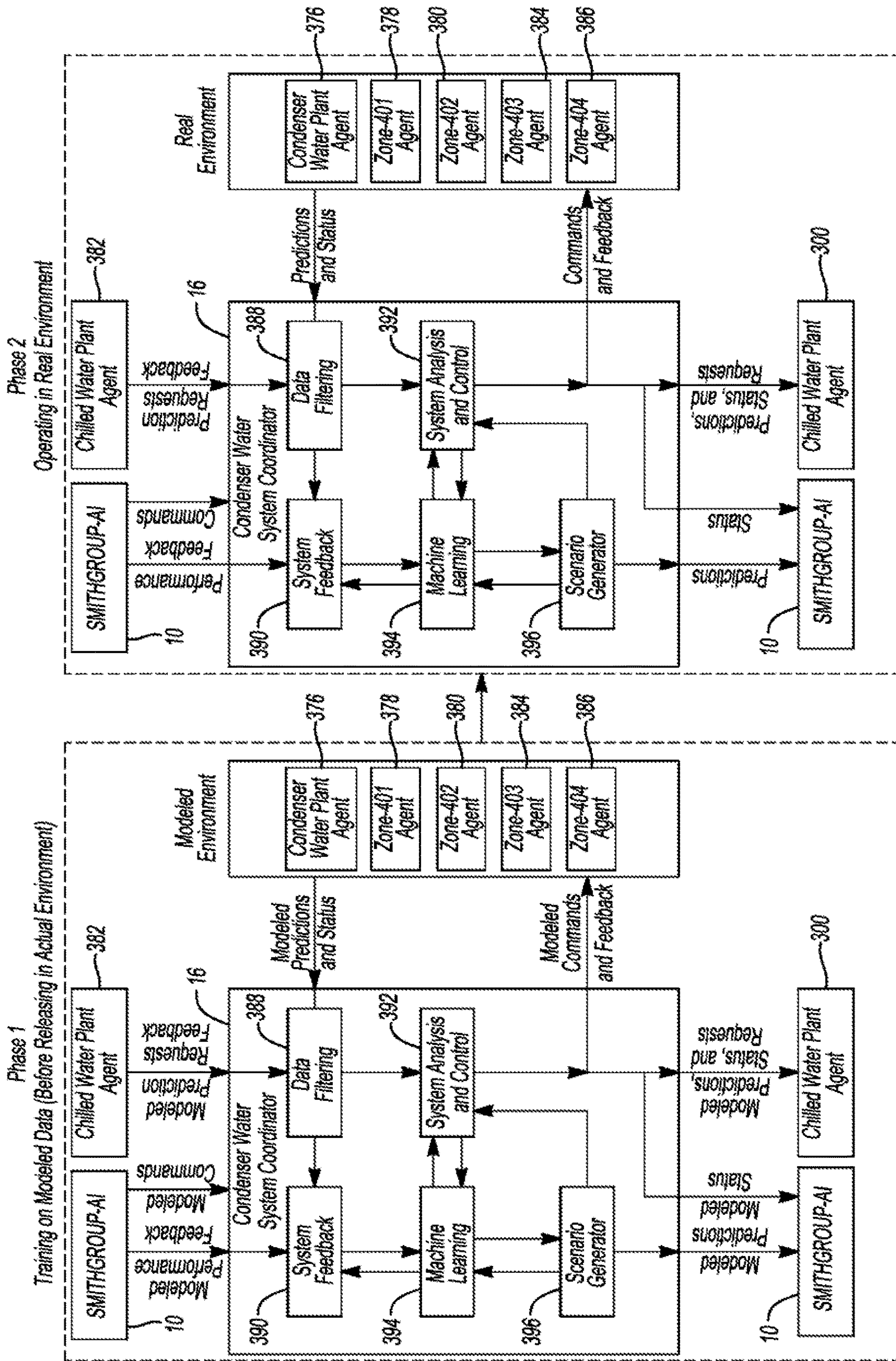

Fig-22

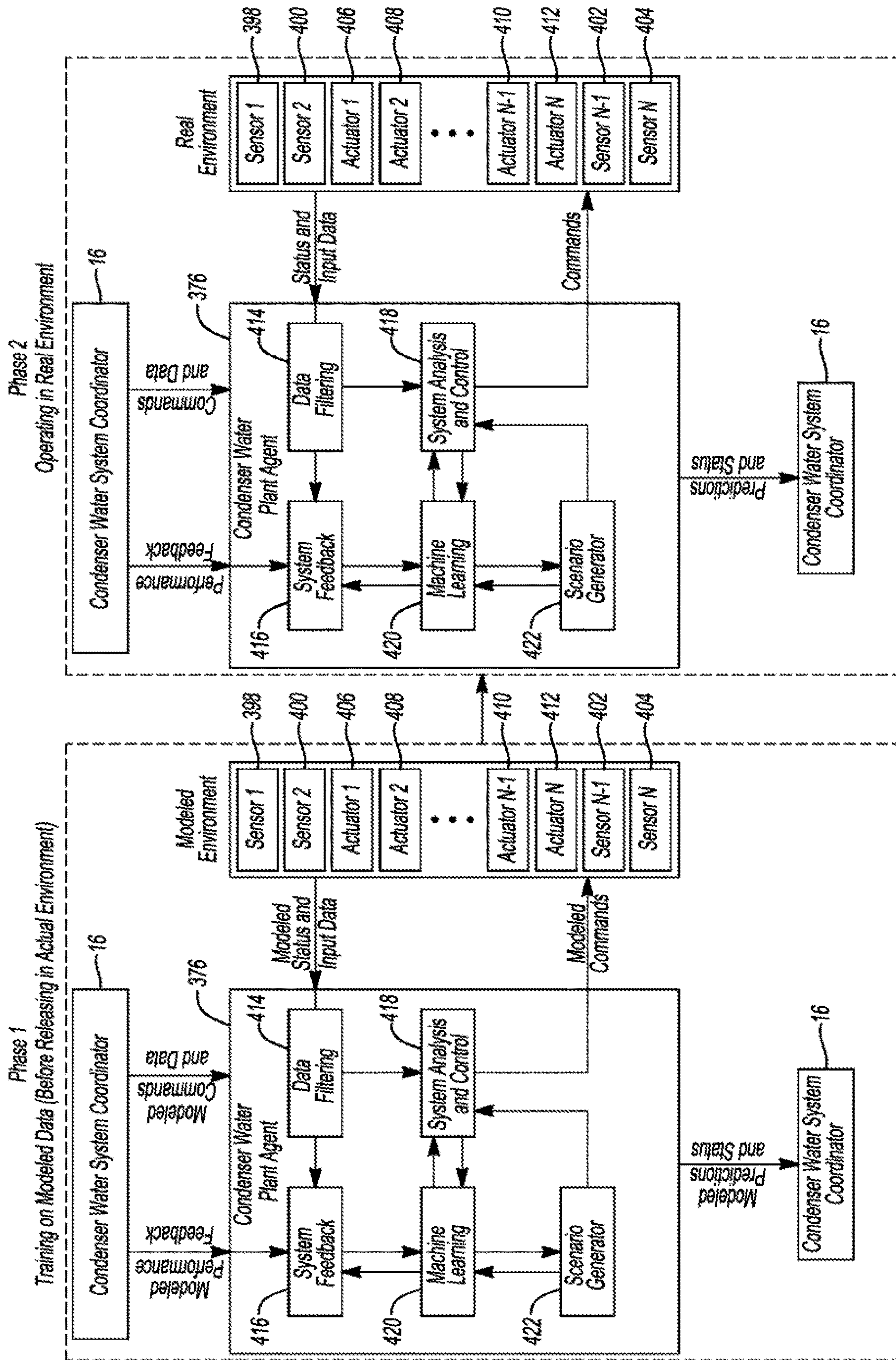

Fig-23

1**INTELLIGENT BUILDING MANAGEMENT SYSTEMS****CROSS-REFERENCE TO RELATED APPLICATION**

This application is a continuation of U.S. patent application Ser. No. 16/436,564, filed Jun. 10, 2019, which claims the benefit of U.S. Provisional Patent Application No. 62/682,746, filed Jun. 8, 2018, both of which are incorporated by reference herein in their entirety.

TECHNICAL FIELD

This disclosure relates to the control of equipment used within buildings.

BACKGROUND

A building management system (BMS), otherwise known as a building automation system (BAS), is a computer-based control system installed in a building that controls and monitors the building's electrical and mechanical equipment such as ventilation, lighting, power systems, fire systems, and security systems. As such, a BMS may also include a variety of devices (e.g., HVAC devices, controllers, chillers, fans, sensors, lighting controllers, lighting fixtures etc.) configured to facilitate monitoring and controlling the building space. Throughout this disclosure, such devices are referred to as BMS devices or building equipment.

Typically, even though the building controllers, input-output devices, and various switching equipment communicate via open source networks such as BACnet, LONworks, Modbus etc. the programming language for each such device is proprietary to the specific manufacturer. The sequences of operation for each system are manually programmed into each controller and then "released" to automatically control their related systems.

SUMMARY

A hierarchical resource management system for a building, that has a plurality of zones each with a corresponding resource arranged to alter an environment of the zone, includes one or more processors. The processors implement a plurality of agents that each monitor sensed values describing conditions of one of the zones, generate operating scenarios based on the sensed values for the resource corresponding to the one of the zones, and operate the resource according to a commanded one of the operating scenarios. Each of the operating scenarios describe an array of set point values for the resource and correspond to an energy consumption of the resource. The processors also implement a coordinator that, responsive to receipt of the operating scenarios from each of the agents, filters the operating scenarios to remove the operating scenarios that violate internal laws of the agents to form an aggregate validated set of operating scenarios. The processors further implement a central brain that, responsive to receipt of target conditions for the zones and the aggregate validated set of operating scenarios from the coordinator, selects a combination of the operating scenarios from the aggregate validated set of operating scenarios that achieves the target conditions and minimizes overall energy consumption by the resources such that some of the operating scenarios of the combination do not minimize energy consumption of the resources corresponding to the some of the operating sce-

2

narios, and directs the coordinator to command operation of the resources according to the combination of the operating scenarios.

BRIEF DESCRIPTION OF THE DRAWINGS

FIG. 1 shows the communication architecture between SMITHGROUP-AI and various system coordinators.

FIG. 2 shows the internal structure of SMITHGROUP-AI and its related environment.

FIG. 3 shows the internal structure of the Zone Agent and its related environment.

FIG. 4 shows the communication architecture between the various agents and coordinators.

FIG. 5 shows the internal structure of the Power and Lighting System Coordinator and its related environment.

FIG. 6 shows the internal structure of the Panelboard Agent and its related environment.

FIG. 7 shows the internal structure of the Renewable Energy Agent and its related environment.

FIG. 8 shows an airside system as having one air handling unit delivering a mixture of outside air and return air to five zones.

FIG. 9 shows the communication architecture between the various Airside System Agents.

FIG. 10 shows the internal structure of the AHU System Coordinator and its related environment.

FIG. 11 shows the internal structure of the AHU Agent and its related environment.

FIG. 12 shows the Heating Plant providing heating hot water to one Air Handling Unit and seven thermal zones.

FIG. 13 shows the communication architecture between the various Hot Water System Agents.

FIG. 14 shows the internal structure of the Hot Water System (HWS) Coordinator and its environment.

FIG. 15 shows the internal structure of the Heating Plant Agent and its related environment.

FIG. 16 shows a chilled water system including four chilled water pumps, pumped in parallel, one waterside economizer heat exchanger, and three chillers.

FIG. 17 shows the communication architecture between the various chilled water system agents.

FIG. 18 shows the internal structure of the Chilled Water System Coordinator and its related environment.

FIG. 19 shows the internal structure of the Chilled Water Plant Agent and its related environment.

FIG. 20 shows a condenser water system including four condenser water pumps and three cooling towers, each with two cells.

FIG. 21 shows the communication architecture between the various Condenser Water System Agents.

FIG. 22 shows the internal structure of the Condenser Water System Coordinator and its related environment.

FIG. 23 shows the internal structure of the Condenser Water Plant Agent and its related environment.

DETAILED DESCRIPTION

Various embodiments of the present disclosure are described herein. However, the disclosed embodiments are merely exemplary and other embodiments may take various and alternative forms that are not explicitly illustrated or described. The figures are not necessarily to scale; some features may be exaggerated or minimized to show details of particular components. Therefore, specific structural and functional details disclosed herein are not to be interpreted as limiting, but merely as a representative basis for teaching

one of ordinary skill in the art to variously employ the present invention. As those of ordinary skill in the art will understand, various features illustrated and described with reference to any one of the figures may be combined with features illustrated in one or more other figures to produce embodiments that are not explicitly illustrated or described. The combinations of features illustrated provide representative embodiments for typical applications. However, various combinations and modifications of the features consistent.

A. SMITHGROUP-AI

1. General Description

SMITHGROUP-AI (supervisor) is an independent, multifunctional software agent responsible for the monitoring and control of all agents that control all building systems. Its main goal is to direct the agents to operate at conditions that result in the lowest possible building energy consumption levels and building energy cost levels. This is achieved by analyzing all possible combinations and associated laws between the various System Coordinator scenarios, and then directing each System Coordinator to implement a scenario that will result in the lowest possible building energy consumption levels. It is not required nor assumed that SMITHGROUP-AI selects the most energy efficient scenario from each System Coordinator. Some System Coordinator scenarios selected to be implemented by SMITHGROUP-AI might not be the most energy cost efficient for that system; however, when analyzed from an overall building energy consumption or energy cost level, those scenarios are collectively the most energy efficient. Further, SMITHGROUP-AI using various known machine learning algorithms may predict the overall building energy consumption and energy cost levels for the following hour, day, week, month and year.

FIG. 1 shows the communication architecture between SMITHGROUP-AI 10 and the various System Coordinators 12, 14, 16, 18, 20, 22.

2. Internal Structure

Referring to FIG. 2, the internal structure of SMITHGROUP-AI 10 and its related environment is shown. The environment for SMITHGROUP-AI 10 is comprised of all System Coordinators 12, 14, 16, 18, 20, 22 that it monitors and controls.

SMITHGROUP-AI 10 is comprised of five modules, each with its own dedicated algorithms and controls logic. The Data Filtering module 24 is responsible for separating the data received from the various coordinators 12, 14, 16, 18, 20, 22. For example, the actual building energy consumption and energy cost levels may be sent to the System Feedback module 26, while energy consumption predictions and associated scenarios from the System Coordinators 12, 14, 16, 18, 20, 22 will be sent to the System Analysis and Control module 28.

The System Feedback module 26 is responsible for the following:

Collection of information from the System Coordinators 12, 14, 16, 18, 20, 22; the information may represent status (e.g. failed, maintenance), or actual agent energy consumption and energy cost levels. A failed status may indicate that a System Coordinator may no longer control its environment and should be excluded from the overall building energy consumption and energy cost level predictions that the Machine Learning module 30 is making. A maintenance status may indicate that a System Coordinator has entered or may enter a maintenance mode and that the Machine Learning module 30 needs to update its predictions accordingly.

The information may also represent predictions related to the energy consumption levels of each agent.

Analysis of predictions related to the total building energy consumption and energy cost levels; the actual energy consumption levels from the various agents will be compared against their own predictions and also against the predictions made by the Machine Learning module 30. Any large discrepancies between the predicted and actual energy consumption and energy cost levels could mean that the associated Scenarios that SMITHGROUP-AI 10 has directed the System Coordinators 12, 14, 16, 18, 20, 22 to execute are no longer valid. This could also indicate that, due to various events (e.g. equipment failures, sensor failures etc.) some agents within the system may conflict with their own internal laws. Further, this could also indicate that the difference in the error or accuracy of the predictions made by the Machine Learning module 30 or by each System Coordinator 12, 14, 16, 18, 20, 22 and the actual outcome might have exceeded critical limits, which in turn has affected the overall energy consumption and energy cost levels of the building. The System Feedback module 26 may then send the actual energy consumption and energy cost levels to the Machine Learning module 30 such that the Machine Learning module 30 can update its internal learning algorithms.

An internal law for an agent may be one (or both) of the following (i) a physical property (e.g. maximum air flow through a fan, maximum water flow through a pump) of a system that the agent is controlling and/or responsible for, (ii) a software or hardware (e.g. computing power) limitation of the agent; e.g. a coordinator may ask an agent to provide predictions for a significantly large (and may be unrealistic) number of scenarios within a limited/short amount of time. This request may impede the agent's ability to control the system that it serves. Agents may report their internal laws to their coordinators such that the coordinators can determine whether certain scenarios generated by one agent violates the internal laws of another agent, etc.

Receiving requests from the HUMAN INTERVENTION Application Programming Interface (API) 32. For example, the System Feedback module 26 may receive a request to simulate what will the total building energy cost (e.g. natural gas or electricity) be if the cost of electricity will increase by 20% starting two months from the current date. The System Feedback module 26 will then send this scenario to the Machine Learning module 30, which in turn may use its own internal algorithms to make predictions regarding the total building energy costs; the Machine Learning module 30 will then send these predictions back to the System Feedback module 26, which in turn will send them to the HUMAN INTERFACE API 32. The Machine Learning module 30 may also determine that, to make the requested predictions, it needs inputs (e.g. energy consumption predictions) from the various System Coordinators 12, 14, 16, 18, 20, 22; as such, it may ask the System Analysis and Control module 28 to direct the various System Coordinators 12, 14, 16, 18, 20, 22 to make the associated predictions and send them back to SMITHGROUP-AI 10 to be processed and analyzed. Further, the System Feedback module 26 may receive a request to simulate what will happen (e.g. what systems are affected and by what degree) if a major piece of equipment (e.g. chiller, boiler) will fail at a certain moment in time. The System Feedback module

5

26 and the Machine Learning module 30 will then follow a process as described in the previous example. Receiving commands from the HUMAN INTERVENTION API 32. For example, the System Feedback module 26 may receive a command to run the entire chilled water plant at 50% capacity or to put a certain piece of equipment (e.g. chiller, boiler, AHU, etc.) in maintenance mode. The System Feedback module 26 will then send this command to the System Analysis and Control module 28 to be analyzed. Before executing the command, the System Analysis and Control module 28 will direct the System Coordinators 12, 14, 16, 18, 20, 22 to simulate what will be the outcomes (e.g. unable to maintain zone temperatures, warmer chilled water temperature, colder hot water temperature, etc.) associated with the command. The System Analysis and Control module 28 will then send these outcomes to the System Feedback module 26, which in turn will send them back to the HUMAN INTERVENTION API 32 for confirmation. Once it receives confirmation from the HUMAN INTERVENTION API 32, via the System Feedback module 26, the System Analysis and Control module 28 will then direct the System Coordinators 12, 14, 16, 18, 20, 22 to execute the command.

The Machine Learning module 30 is responsible for the following:

Collection of information from the System Feedback module 26. The type of information that this module will collect is described under the System Feedback module 26.

Collection of information from the System Analysis and Control module 28. This information may represent prediction scenarios from System Coordinators 12, 14, 16, 18, 20, 22 regarding energy consumption levels associated with each system.

receiving prediction requests from the System Analysis and Control module 28. For example, the System Analysis and Control module 28, after it analyzed and established what combination of System Coordinator scenarios will need to be executed, may send these scenarios to the Machine Learning module 30. The Machine Learning module 30, using machine learning algorithms and historical data, may predict that the combination of System Coordinator scenarios selected by the System Analysis and Control module 28 will not result in the lowest possible energy consumption and energy cost levels for the entire building. The Machine Learning module 30 will then send this output to the System Analysis and Control module 28 for analysis.

Making predictions, using machine learning algorithms, based on the data received from the System Analysis and Control module 28, for the overall building energy consumption or energy cost levels. In addition, the Machine Learning module 30 may also make predictions related to the peak electricity demand for the entire building. For example, by analyzing the electricity peak demand charge rate schedule from the utility provider, and with input from the System Analysis and Control module 28, the Machine Learning module 30 may predict that, at a certain time in the day, the facility peak electricity demand may exceed a value after which the facility will incur significant surcharges. The Machine Learning module 30 may then send this prediction to the System Analysis and Control module 28, which in turn may direct the System Coordinators 12, 14, 16, 18, 20, 22 to analyze various scenarios for

6

their related systems and agents to minimize the overall peak facility electricity demand at that time in the day. The Systems Coordinators 12, 14, 16, 18, 20, 22 will then send back their associated predictions, together with any system constraints or laws that they might not be able to meet should they be directed to implement the associated scenarios. For example, AHU-1 System Coordinator 20 may determine that, to reduce the energy consumption of the AHU fans, some zones, based on their importance factor, may have to have their temperature setpoints increased or decreased. (Zone and system are sometimes used interchangeably herein.) This approach could put a Zone Agent in conflict with its own internal laws. The System Analysis and Control module 28 will then analyze the predicted scenarios received from the AHU-1 System Coordinator 20 and it may decide to direct the System Coordinators 12, 14, 16, 18, 20, 22 to execute the scenarios associated with the combination that result in a peak facility electricity demand lower than the critical value, even though this command may put various agents in conflict with their own internal laws.

Sending the predictions to the System Analysis and Control module 28 and to the Scenario Generator module 34.

The System Analysis and Control module 28 is responsible for the following:

Monitoring and control of all System Coordinators 12, 14, 16, 18, 20, 22.

Collection of information from the Data Filtering module 24. The type of information that this module will collect is described under the Data Filtering module 24. The System Analysis and Control module 28 may then analyze all possible System Coordinator scenario combinations and select the combination that will result in the lowest possible building energy consumption or energy cost levels. After establishing the combination that will result in the lowest possible building energy consumption or energy cost levels, the System Analysis and Control module 28 may direct the System Coordinators 12, 14, 16, 18, 20, 22 to execute the scenarios associated with that specific combination.

Collection of information from the System Feedback module 26. The type of information that this module will collect is described under the System Feedback module 26.

Receiving predictions made by the Machine Learning module 30. The type of predictions that the Machine Learning module 30 may send to the System Analysis and Control module 28 is described in the Machine Learning module 30 section above. Based on the input (e.g. equipment failures, unoccupied zones previously predicted to be occupied zones, etc.) provided by the System Coordinators 12, 14, 16, 18, 20, 22, the System Analysis and Control module 28 may decide to override the predictions made by the Machine Learning module 30 and direct the System Coordinators 12, 14, 16, 18, 20, 22 to implement the combination of scenarios previously established. The System Analysis and Control module 28 may also decide to direct the System Coordinators 12, 14, 16, 18, 20, 22 to update their predictions and send them back to SMITH-GROUP-AI 10 for analysis.

The Scenario Generator module 34 is responsible for continuously looking for ways to improve the overall energy or energy cost performance of the building. For example, the Scenario Generator module 34 may create a series of sce-

narios which will then be sent to the System Analysis and Control module **28** to analyze and validate; the System Analysis and Control module **28** may ask the System Coordinators **12, 14, 16, 18, 20, 22** to make predictions on the scenarios generated by the Scenario Generator module **34**. Once the associated System Coordinator predictions are received and validated, the System Analysis and Control module **28** will establish which combinations of scenarios may result in the lowest energy consumption or energy cost level. The System Analysis and Control module **28** will then send these combinations to the Machine Learning module **30** to make predictions, as previously described, or it may send them back to the Scenario Generator module **34** for analysis. After analyzing the predictions made by the Machine Learning module **30** or the System Coordinator combination scenarios received from the System Analysis and Control module **28**, the Scenario Generator module **34** may decide to direct the System Analysis and Control module **28** to implement a specific combination of System Coordinator scenarios. The System Analysis and Control module **28** will then direct the System Coordinators **12, 14, 16, 18, 20, 22** to execute the scenarios associated with that specific combination.

The Scenario Generator module **34** may create scenarios by modelling Zone Agents under different conditions (e.g. various zone temperature setpoints, various supply airflow setpoints and associated temperature, various lighting loads, various plug loads, etc.), by modelling AHUs as delivering various airflows at various temperatures, by modelling the Chilled Water Plant as delivering various chilled water temperatures and various associated chilled water flows, by modelling the Condenser Water Plant as delivering various condenser water temperatures and condenser water flows, or by modeling the Hot Water Plant as delivering various hot water temperatures and associated water flows, etc.

B. Zone Agent

1. General Description

The zone agent is an independent, multifunctional software agent responsible for management of zones throughout the building. A “zone” can be comprised of one or more rooms, one or more lighting control zones, one or more receptacle control zones, and one or more heating/cooling terminal units. The functions and responsibilities of the zone agent include but are not limited to:

- Prediction of current and future heating and cooling loads.
- Measurement of current occupancy and prediction of future occupancy.
- Prediction of terminal unit reheat coil performance under various combinations of entering air temperature, entering water temperature, etc.
- Prediction of terminal unit cooling coil performance under various combinations of entering air temperature, entering water temperature, etc.
- Prediction of terminal unit energy consumption under various combinations of entering air temperature, entering water temperatures, etc.
- Modulation of terminal unit actuators to satisfy room heating and cooling as directed by SMITHGROUP-AI **10**.
- Zone lighting control.
- Zone receptacle control for switched receptacle circuits.
- Monitoring of total zone power consumption.
- Monitoring of zone receptacle power consumption and prediction of future zone receptacle power consumption.
- Operation of motorized shading.
- Airflow/Ventilation optimization.

2. Internal Structure

Referring to FIG. 3, the internal structure of the Zone Agent **36** and its related environment is shown. The environment for the Zone Agent **36** is comprised of the sensors **38, 40, 42, 44** within the zone, global sensors, weather data from an internet source (API) **46, 48**, and effectors **50, 52, 54, 56** within the zone. The agent **36** is comprised of four modules, each with its own dedicated algorithms and controls logic.

The System Feedback module **58** is responsible for the following:

Collection of information from all associated sensors **38, 40, 42, 44**, data sources **46, 48**, and effectors **50, 52, 54, 56**; the data received will be compared against the predictions made by the Machine Learning module **60**. Where appropriate, a time delay will be implemented when comparing the measured data to predictions; data will also be compared to historical data to allow for the filtering of outlier data that may be caused by a malfunctioning sensor or atypical temporary conditions. Once the implementation of appropriate time delays and filtering is complete, the System Feedback module **58** will then send the measured values to the Machine Learning module **60** such that the Machine Learning module **60** can update its internal learning algorithms.

The Machine Learning module **60** is responsible for the following:

Collection of information from the System Feedback module **58**.

Making predictions using machine learning algorithms. Sending predictions to the System Analysis and Control module **62**, and associated higher level coordinators where applicable.

The Machine Learning module **60** will contain numerous machine learning algorithms, including, but not limited to the following.

1. Current sensible heating/cooling load prediction algorithm. This algorithm will predict the current sensible heating or cooling load in Btu/hr for the zone. Data inputs used may include, but not be limited to the following: zone temperature setpoint, zone temperature, zone relative humidity setpoint, zone relative humidity, daylighting, total lighting heat output, outdoor air temperature, outdoor air dew point, outdoor air wind speed, outdoor air wind direction, current motorized shade position, current number of occupants, and current plug load. Initially, a data set produced using a load simulation software will be used to train a machine learning algorithm. This will be referred to as a “pre-trained algorithm.” Upon implementation, the agent **36** will build a new data set using real operational data to train a new machine learning algorithm which will be referred to as an “operational algorithm.” The feedback used to train the operational algorithm will be zone temperature drift after a specified period. The agent **36** will continue to use the pre-trained algorithm until the operational algorithm has achieved a specified level of accuracy—at which point the transition will occur. If the operational algorithm data should become inaccurate, the agent **36** will revert to the pre-trained algorithm. For example, if SMITHGROUPAI **10** is implemented during a period of warm weather, the operational algorithm may become accurate enough to take over from the pre-trained algorithm within one to two months. However, the temperature may drop after several months at which point the algorithm may become inaccurate due to not having accrued enough

training data for periods of cold weather. Should this occur, the agent **36** may revert to using the pre-trained algorithm, until such a time that the operational algorithm has built up enough training data and achieved the specified level of accuracy. Note that the data sets for the pre-trained algorithm, and operational algorithm will never be mixed—this transition type will be referred to as a “hand-off transition.”

2. Current latent dehumidification/humidification load prediction algorithm: this algorithm will predict the current latent dehumidification/humidification load in Btu/hr for the zone. Data inputs used may include, but not be limited to the following: zone relative humidity setpoint, zone relative humidity, outdoor air dew point, outdoor air wind speed, outdoor air wind direction, current number of occupants, and current plug load. Initially, a data set produced using load simulation software will be used to train a machine learning algorithm. This will be referred to as a “pre-trained algorithm.” Upon implementation, the agent **36** will build a new data set using real operational data to train a new machine learning algorithm that will be referred to as the “operational algorithm.” The feedback used to train the operational algorithm will be zone relative humidity drift after a period of time. The transition from the pre-trained algorithm to the operational algorithm shall be a hand-off transition. Refer to machine learning algorithm one for additional information.
3. Future sensible heating/cooling load prediction algorithm. This algorithm will predict future sensible heating/cooling load in Btu/hr for the zone. Data inputs used may include, but not be limited to the following: predicted zone temperature setpoint, predicted number of occupants, predicted total lighting heat output, predicted plug load, future outdoor air temperature (via API), future outdoor air wind speed (via API), future outdoor air wind direction (via API), future solar azimuth (via API), future solar altitude (via API), future cloud cover (via API), and predicted motorized shade position. Initially, a data set produced using load simulation software will be used to train a machine learning algorithm. This will be referred to as a “pre-trained algorithm.” Upon implementation, the agent **36** will build a new data set using real operational data to train a new machine learning algorithm which will be referred to as the “operational algorithm.” The feedback used to train the operational algorithm will be the actual cooling load. This process represents an indirect feedback loop in which each prediction the algorithm makes will not necessarily receive feedback. For example, if the operational algorithm predicts that a zone cooling load will be 10,000 Btu/hr in five hours based on the forecasted weather data in which total cloud cover is expected, but in five hours’ time, the cloud cover is minimal, the prediction will be inaccurate. However, the cause of the inaccuracy was the uncertainty of the weather forecast rather than an issue with the algorithm. For this reason, the algorithm will monitor real time cooling load and the data inputs described above that occur simultaneous to the real time cooling load to build the data set. The transition from the pre-trained algorithm to the operational algorithm will be a hand-off transition. Refer to machine learning algorithm one for additional information.
4. Future latent dehumidification/humidification load prediction algorithm. This algorithm will predict the future latent dehumidification/humidification load in Btu/hr

- for the zone. Data inputs used may include, but not be limited to the following: predicted zone relative humidity setpoint, predicted number of occupants, future outdoor air dew point (via API), future outdoor air wind speed (via API), future outdoor air wind direction, and predicted plug load. Initially, a data set produced using load simulation software will be used to train a machine learning algorithm. This will be referred to as a “pre-trained algorithm.” Upon implementation, the agent **36** will build a new data set using real operational data to train a new machine learning algorithm that will be referred to as the “operational algorithm.” The feedback used to train the operational algorithm will be the actual latent dehumidification/humidification load. This process represents an indirect feedback loop. Refer to machine learning algorithm three for additional information on feedback. The transition from pre-trained algorithm to the operational algorithm will be a hand-off transition. Refer to machine learning algorithm one for additional information.
5. Future temperature setpoint prediction algorithm. This algorithm will predict the future temperature setpoint for any given time. Data inputs used may include, but not be limited to the following: day of the week, day type (holiday/non-holiday), and time. Initially, a setpoint schedule will be produced to train a machine learning algorithm. This will be referred to as a “pre-trained algorithm.” Upon implementation, the agent **36** will build a new data set using real operational data to train a new machine learning algorithm that will be referred to as the “operational algorithm.” The feedback used to train the operational algorithm will be actual setpoint data. A complete transition from the pre-trained algorithm to the operational algorithm will take place after a specified period. Both the pre-trained and operational algorithm may be overridden by user intervention or in coordination with a room scheduling platform.
 6. Future relative humidity setpoint prediction algorithm. This algorithm will predict the future relative humidity setpoint for any given time. Data inputs used may include, but not be limited to the following: day of the week, day type (e.g. holiday/non-holiday), and time. Initially, a setpoint schedule will be produced to train a machine learning algorithm. This will be referred to as a “pre-trained algorithm.” Upon implementation, the agent will build a new data set using real operational data to train a new machine learning algorithm that will be referred to as the “operational algorithm.” The feedback used to train the operational algorithm will be actual setpoint data. A complete transition from the pre-trained algorithm to the operational algorithm will take place after a specified period. Both the pre-trained and operational algorithm may be overridden by user intervention or in coordination with a room scheduling platform.
 7. Predicted number of occupants algorithm. This algorithm will predict the future number of occupants for any given time. Data inputs used may include, but not be limited to the following: day of the week, day type (e.g. holiday/non-holiday), and time. Initially, a setpoint schedule will be produced to train a machine learning algorithm. This will be referred to as a “pre-trained algorithm.” Upon implementation, the agent **36** will build a new data set using real operational data to train a new machine learning algorithm that will be referred to as the “operational algorithm.” The feed-

11

back used to train the operational algorithm will be actual number of occupants as sensed by a people counter or as calculated using room CO₂ levels. A complete transition from the pre-trained algorithm to the operational algorithm will take place after a specified period. Both the pre-trained and operational algorithm may be overridden by user intervention or in coordination with a room scheduling platform.

8. Predicted plug load. This algorithm will predict the future plug load for any given time. Data inputs used may include, but not be limited to the following: day of the week, day type (e.g. holiday/non-holiday), predicted number of occupants, and time. Initially, a setpoint schedule will be produced to train a machine learning algorithm. This will be referred to as a “pre-trained algorithm.” Upon implementation, the agent **36** will build a new data set using real operational data to train a new machine learning algorithm that will be referred to as the “operational algorithm.” The feedback used to train the operational algorithm will be the actual plug load as sensed by the meter on the associated receptacle circuit. The transition from the pre-trained algorithm to the operational algorithm will be a hand-off transition. Refer to machine learning algorithm one for additional information.
9. Future perimeter zone lighting control signal. This algorithm will predict the future lighting control signal for the exterior lighting control zone within a zone for any given time. Data inputs used may include, but not be limited to the following: predicted number of occupants, future solar azimuth, future solar altitude, future cloud cover, and future motorized shade position. Each lighting circuit will be sub metered. Upon building start up, the Scenario Generator module **64** in combination with the System Analysis and Control module **62** will turn off all but one lighting zone at a time and modulate from minimum to maximum a lighting control signal while the System Feedback module **58** records the metered wattage associated with each lighting control signal. Therefore, the predicted perimeter zone lighting control signal can be used to predict exterior zone lighting heat output in Btu/hr. The process described above also applies to the middle, and interior lighting control zones.
10. Future middle zone lighting control signal. This algorithm will predict the future lighting control signal for the middle lighting control zone within a zone for any given time. Refer to machine learning algorithm nine for additional information.
11. Future interior zone lighting control signal. This algorithm will predict the future lighting control signal for the interior lighting control zone within a zone for any given time. Refer to machine learning algorithm nine for additional information.
12. Future total lighting heat output: this algorithm will predict the total lighting heat output for any given time. Data inputs may include but not be limited to the following: future perimeter zone lighting control signal, future middle zone lighting control signal, interior zone lighting control signal. Initially, a data set produced using load simulation software will be produced to train a machine learning algorithm. This will be referred to as a “pre-trained algorithm.” Upon implementation, the agent **36** will build a new data set using real operational data to train a new machine learning algorithm that will be referred to as the “operational algorithm.” The feedback used to train the operational

12

algorithm will be the actual lighting control signals. This process represents an indirect feedback loop. Refer to machine learning algorithm three for additional information on feedback. The transition from the pre-trained algorithm to the operational algorithm will be a hand-off transition. Refer to machine learning algorithm one for additional information.

13. Predicted change in temperature rate. This algorithm will predict the rate at which the temperature in the zone will change. Data inputs used may include, but not be limited to airflow (CFM), and a differential between predicted zone load (Btu/hr) and the heating/cooling provided to the zone (Btu/hr). Initially, a data set produced using mathematical formulas and the volume of the space will be produced to train a machine learning algorithm. This will be referred to as a “pre-trained algorithm.” Upon implementation, the agent will build a new data set using real operational data to train a new machine learning algorithm that will be referred to as the “operational algorithm.” The feedback used to train the operational algorithm will be the actual change in temperature rate. The Scenario Generator module **64**, in combination with the System Analysis and Control module **62** will be responsible for changing the airflow and Btu/hr offset to the space during unoccupied periods to build the training set for the operational algorithm. The transition from the pre-trained algorithm to the operational algorithm will be a hand-off transition. Refer to machine learning algorithm one for additional information.
14. Predicted change in relative humidity rate. This algorithm will predict the rate at which the relative humidity in the zone will change. Data inputs used may include, but not be limited to airflow (CFM), and a differential between predicted zone load (Btu/hr) and the dehumidification/humidification provided to the zone (Btu/hr). Initially, a data set produced using mathematical formulas and the volume of the space will be produced to train a machine learning algorithm. This will be referred to as a “pre-trained algorithm.” Upon implementation, the agent will build a new data set using real operational data to train a new machine learning algorithm that will be referred to as the “operational algorithm.” The feedback used to train the operational algorithm will be the actual change in relative humidity rate. The Scenario Generator module **64**, in combination with the System Analysis and Control module **62** will be responsible for changing the airflow and Btu/hr offset to the space during unoccupied periods to build the training set for the operational algorithm. The transition from pre-trained algorithm to the operational algorithm will be a hand-off transition. Refer to machine learning algorithm one for additional information.
15. Hydronic coil characteristics. This algorithm will predict the leaving water temperature, and flow rate. Data inputs used may include, but not be limited to airflow, entering water temperature, entering air temperature, and leaving air temperature. Initially, a data set produced by mapping coil characteristics using manufacturer’s data will be used to train a machine learning algorithm. This will be referred to as a “pre-trained algorithm.” Upon implementation, the agent will build a new data set using real operational data to train a new machine learning algorithm that will be referred to as the “operational algorithm.” The feedback used to train the operational algorithm will be the

actual leaving water temperature and flow rate. The transition from the pre-trained algorithm to the operational algorithm will be a hand-off transition. Refer to machine learning algorithm one for additional information.

16. Energy consumption. This algorithm will predict the terminal unit energy consumption for various operating scenarios. Data inputs used may include, but not be limited to the following: primary airflow (CFM) and fan airflow (CFM). Initially, a data set produced using manufacturer's data will be used to train a machine learning algorithm. This will be referred to as a "pre-trained algorithm." Upon implementation, the agent will build a new data set using real operational data to train a new machine learning algorithm that will be referred to as the "operational algorithm." The feedback used to train the operational algorithm will be the actual terminal unit energy consumption. The transition from the pre-trained algorithm to the operational algorithm will be a hand-off transition. Refer to machine learning algorithm one for additional information.
17. Airflow algorithm. This algorithm will determine the amount of airflow the zone will receive for each potential entering air temperature. Data inputs used may include, but not be limited to the following: zone heating/cooling load, zone humidification/dehumidification load, entering air temperature, entering air dew point, number of occupants, zone CO₂ concentration, zone VOC concentration, zone airborne particulate concentration, and air handling unit system ventilation efficiency. The algorithm will produce a single airflow value for each potential entering air temperature. Initially, a data set produced using load simulation software will be used to train a machine learning algorithm. This will be referred to as a "pre-trained algorithm." Upon implementation, the agent 36 will build a new data set using real operational data to train a new machine learning algorithm that will be referred to as the "operational algorithm." The feedback used to train the operational algorithm will be zone relative humidity drift after a period. The transition from the pre-trained algorithm to the operational algorithm shall be a hand-off transition. Refer to machine learning algorithm one for additional information. The algorithm will be constrained by high and low limits—referred to as laws which can be reset through user intervention or by direction from SMITHGROUP-AI 10, the Scenario Generator module 64, and the System Analysis and Control module 62.
18. Predicted zone receptacle power consumption. This algorithm will predict the total zone receptacle power consumption for any given time. The purpose of this algorithm is to predict the energy consumption of various equipment such as kitchen appliances, computers, data servers, etc. Data inputs used may include, but not be limited to the following: number of occupants, time, day of week, and day type (e.g. holiday or non-holiday). Initially, a data set produced using load simulation software will be used to train a machine learning algorithm. This will be referred to as a "pre-trained algorithm." Upon implementation, the agent 36 will build a new data set using real operational data to train a new machine learning algorithm that will be referred to as the "operational algorithm." The feedback used to train the operational algorithm will be actual zone receptacle power consumption as measured by the meter on the associated receptacle circuit. The

transition from the pre-trained algorithm to the operational algorithm shall be a hand-off transition. Refer to machine learning algorithm one for additional information.

- 5 Various algorithms described above can be limited to a specific range using lower, and higher limit laws.

The machine learning algorithm outputs will form a data set of potential operating scenarios which will be shared with the AHU System coordinators 20, 22, Chilled Water System Coordinator 16, Condenser Water System Coordinator 12, Heating Hot Water System Coordinator 18, and Power System Coordinator 14, where applicable. For example, if a zone agent 36 is responsible for the control of a chilled water fan coil unit, the Zone Agent 36 will send data sets to the appropriate one of the AHU System Coordinators 20, 22, and Chilled Water System Coordinator 16; if the Zone Agent 36 is responsible for the control of a VAV box with a heating hot water reheat coil, the Zone Agent 36 will send data to the appropriate one of the AHU System Coordinators 20, 22 and the Heating Hot Water System Coordinator 18.

In addition to the algorithms described above, zones which feature frequent dry bulb temperature/dew point temperature setpoint changes will include the following algorithms. The algorithms below can be used in combination with scheduled/predicted future setpoints.

19. Temperature setpoint change, this algorithm will predict the amount of time required to heat or cool a zone between two temperature setpoints. Data inputs may include, but not be limited to the following: initial setpoint, final setpoint, airflow (CFM), current sensible heating/cooling load, future sensible heating/cooling load, number of occupants, and discharge air temperature. Initially, a data set produced using mathematical formulas (e.g. HVAC formulas, differential equations etc.) and the volume of the room will be used to train a machine learning algorithm. This will be referred to as a "pre-trained algorithm." Upon implementation, the agent 36 will build a new data set using real operational data to train a new machine learning algorithm which will be referred to as the "operational algorithm." The feedback used to train the operational algorithm will be the actual amount of time required to heat or cool the zone from the initial or final temperature. The Scenario Generator module 64, in combination with the System Analysis and Control module 62 will be responsible for running test scenarios where the temperature setpoint is changed during unoccupied periods. The tests will be conducted using various airflows and discharge air temperatures to build the operational algorithm's data set. Once the operational algorithm is implemented, the Scenario Generator module 64 in combination with SMITHGROUP-AI 10 and the System Analysis and Control module 62 will calculate various scenarios for heating/cooling the room from the initial to final setpoint and determine which method is most economical. For example, consider a room scheduled or predicted to be occupied from 8:00 AM to 9:30 AM with a setpoint of 80° F., scheduled or predicted to be unoccupied from 9:30 AM to 10:00 AM, and scheduled or predicted to be occupied from 10:00 AM to 11:00 AM with a setpoint of 60° F. Therefore, the system will have 30 minutes to cool the room from 80° F. to 60° F. The Scenario Generator module 64 in combination with SMITHGROUP-AI 10 and the System Analysis and Control module 62 will evaluate whether it is more economical to cool the room slowly over a longer period of time (up

to 30 minutes) or quickly over a short period of time—and when that short period of time should be—for example, if the cloud cover is expected to clear at 9:45 AM—thus increasing the cooling loads and energy associated with meeting the loads—then it may be more energy or energy cost efficient to cool the room quickly between 9:30 AM and 9:45 AM, then maintain the temperature for the following 15 minutes. The transition from the pre-trained algorithm to the operational algorithm shall be a hand-off transition. Refer to machine learning algorithm one for additional information. The strategies described above also apply to machine learning algorithm twenty.

20. Dew point temperature setpoint change. This algorithm will predict the amount of time required to heat or cool a zone between two dew point temperature setpoints. Note that dew point is used as opposed to relative humidity as the dew point setpoint change will often coincide with a dry bulb temperature change. Data inputs may include, but not be limited to the following: initial setpoint, final setpoint, airflow (CFM), current latent dehumidification/humidification load, future latent dehumidification/humidification load, number of occupants, and entering air dew point temperature. Initially, a data set produced using mathematical formulas and the volume of the room will be used to train a machine learning algorithm. This will be referred to as a “pre-trained algorithm.” Upon implementation, the agent 36 will build a new data set using real operational data to train a new machine learning algorithm which will be referred to as the “operational algorithm.” The feedback used to train the operational algorithm will be the actual amount of time required to humidity or dehumidify the zone from the initial or final dew point temperature. Refer to machine learning algorithm nineteen for additional information. The transition from the pre-trained algorithm to the operational algorithm shall be a hand-off transition. Refer to machine learning algorithm one for additional information.

The System Analysis and Control module 62 is responsible for the following:

Monitoring and control of all sensors 38, 40, 42, 44 and actuators 50, 52, 54, 56 related to the Zone Agent 36.

Analyzing the data from each sensor and actuator. For example, the System Analysis and Control module 62 may determine that due to a flex duct being kinked, higher end airflow values can no longer be provided, and update the high limit airflow law for the airflow algorithm.

Sending the valid system scenarios to the Machine Learning module 60 for predictions.

Sending commands to the various zone effectors 50, 52, 54, 56. The commands could be valve position, lighting control signal, damper position, or shade position.

Analyzing the scenarios proposed by the Scenario Generator module 64. For example, if SMITHGROUP-AI 10 determines that the zone in question is considered critical (e.g. is the zone preventing the HVAC system from operating at a more energy efficient condition), then the Scenario Generator 64 shall create scenarios to be analyzed by the System Analysis and Control module 62 such as relaxing the temperature or relative humidity set point or lowering the motorized shades. The System Analysis and Control module 62 shall evaluate the created options and determine if they are acceptable based on the current zone occupant number,

and the zone importance factor: a numerical value between 0-10 indicating how important space temperature and lighting levels are. For zones with high importance factors such as main conference rooms etc., the System Analysis and Control module 62 may determine that certain scenarios such as relaxing temperature setpoints are not acceptable. If determined to be acceptable, the System Analysis and Control module 62 will send the scenario to the Machine Learning module 60 for predictions.

The Scenario Generator module 64 is responsible for receiving data from SMITHGROUP-AI 10, via its associated System Coordinator, and generating new operating scenarios for the zone in response. For example, SMITHGROUP-AI 10 may determine that the zone is the most critical from a ventilation standpoint. In response, the Scenario Generator module 64 may request that the System Analysis and Control module 62 raise the airflow algorithm minimum airflow law to provide more airflow to the zone.

3. Sample Process

Refer to AHU System, Chilled Water System, and Heating Hot Water System for examples of the data sets produced by the zone agent 36 and how they are used.

C. Power and Lighting Systems

1. General Description

Considering a power monitoring and controls system, the electricity consumption of each zone circuit within the lighting panelboard and within the power panelboard is monitored via a dedicated meter. Further, the power for each zone circuit within the lighting panelboard and within the power panelboard may be turned on and off via the dedicated circuit breaker. All sensors and actuators are connected directly to the network, without the use of proprietary controllers that operate with programmed sequences of operation. In some instances, an open source non-proprietary input/output module or a gateway may be required to convert the signal from a sensor or an actuator such that it can be communicated via open source networks such as BACnet, LONworks, Modbus, etc.

Considering a renewable energy power monitoring and controls system, the controls of the wind turbines and of the solar panels are done through the manufacturer provided proprietary control panels. The control panels are connected to the network through integration via open source non-proprietary input/output modules or gateways. In some instances, the sensors and actuator associated with the wind turbine controls systems and solar panel controls systems may be connected directly to the network thru non-proprietary input/output modules or gateways.

The control of the entire power system is performed through a series of independent software agents such as the Power and Lighting System Coordinator 66, Lighting and Power Panelboard Agents 68, 70, Utility Agent 72, Renewable Energy Agent 74, and Zone Agents 36', 36". The communication architecture between the various agents and coordinators is shown in FIG. 4.

2. Power and Lighting System Coordinator

a. Purpose

The Power and Lighting System Coordinator 66 is an independent software agent that monitors and controls all agents associated with the power and lighting control systems. Further, the Power and Lighting System Coordinator 66 is responsible for the following:

Prediction of the energy use of all building systems.

Prediction of the energy generation from the renewable systems.

Communication with SMITHGROUP-AI 10: sends over-
all power use and power available predictions and
receives commands from SMITHGROUP-AI 10.

Communication with the Panelboard Agents 68, 70:
requests power use predictions and status from the
Panel Agents 68, 70.

Communication with the Renewable Energy Agent 74:
request power available predictions and status from the
Renewable Energy Agent 74.

Communication with the Zone Agents 36', 36'': receives
commands and feedback from the Zone Agents 36',
36''.

Communication with the Utility Agent 72: receives utility
status (e.g. loss of power).

b. Internal Structure

Referring to FIG. 5, the internal structure of the Power
and Lighting System Coordinator 66 and its related envi-
ronment is shown. The environment for the Lighting and
Power System Coordinator 66 is comprised of all the agents
that it monitors and controls. The agent is comprised of five
modules, each with its own dedicated algorithms and con-
trols logic.

The Data Filtering module 76 is responsible for separating
the data received from the various agents 36', 36'', 68, 70, 72,
74. For example, the actual agent power consumption levels
will be sent to the System Feedback module 78, while
predictions from the agents 36', 36'', 68, 70, 72, 74 will be
sent to the System Analysis and Control module 80.

The System Feedback module 78 is responsible for the
following:

Collection of information from the Zone Agents 36', 36'',
Panelboard Agents 68, 70, Utility Agent 72, and
Renewable Energy Agent 74; the information may
represent status (e.g. failed, maintenance) or predic-
tions related to the energy that may be generated by the
Renewable Energy Agent 74. A failed status may
indicate that an agent may no longer control its envi-
ronment and should be excluded from the overall
power system predictions that the Machine Learning
module 82 is making. A maintenance status may indi-
cate that an agent has entered or may enter into a
maintenance mode and that the Machine Learning
module 82 needs to update its overall power system
predictions accordingly.

Analysis of predictions related to the total power system
consumption. The actual meter data from the various
agents 36', 36'', 68, 70, 72, 74 will be compared against
their own predictions and against the predictions made
by the Machine Learning module 82. Any large dis-
crepancies between the predicted and actual power
usage could mean that the previous command that one
of the Zone Agents 36', 36'' or the Renewable Energy
agent 74 received from the Power Coordinator 66 has
placed one of the Zone Agents 36', 36'' or the Renew-
able Energy agent 74 in conflict with its own internal
laws (e.g. not able to meet the various power require-
ments). This could indicate that the difference in the
error or accuracy of the predictions made by the
Machine Learning module 82 and the actual outcome
might have exceeded critical limits, which in turn has
affected the overall performance of the renewable
energy system. The System Feedback module 78 will
then send the actual meter data to the Machine Learn-
ing module 82 such that the Machine Learning module
82 can update its internal learning algorithms.

Collection of information from SMITHGROUP-AI 10.
The information may represent commands that need to

be distributed to the various associated agents 36', 36'',
68, 70, 72, 74. The information may also represent
feedback regarding the predictions that the Lighting
and Power System Coordinator 66 has made; for
example, the predicted energy performance of the Sce-
nario that SMITHGROUP-AI 10 has directed the
Lighting and Power System Coordinator 66 to imple-
ment is significantly different that the real outcome. As
such the System Feedback module 78 will pass this
feedback to the Machine Learning module 82 to update
its machine learning algorithms accordingly such that
the accuracy or error of its predictions self-improve.

Collection of information from the Utility Agent 72. The
information may represent status of the available utility
power. For example, should the building experience a
loss of power, the Lighting and Power System Coor-
dinator 66 will need to notify SMITHGROUP-AI 10 of
such condition. SMITHGROUP-AI 10 may then direct
all System Coordinators to operate under an emergency
power mode until the Utility Agent 72 notifies that
utility power is available.

The Machine Learning module 82 is responsible for the
following:

Collection of information from the System Feedback
module 78. The type of information that this module
will collect is described under the System Feedback
module 78.

Collection of information from the System Analysis and
Control module 80. This information may represent
predictions from the various agents 36', 36'', 68, 70, 72,
74 regarding available power or used power.

Making predictions, using machine learning algorithms,
based on the data received from the System Analysis
and Control module 80, for the overall energy con-
sumption of the entire system or for the total energy
that the Renewable Power agent 74 may need to deliver
or can deliver.

Sending the predictions to the System Analysis and Con-
trol module 80 and to the Scenario Generator module
84.

The System Analysis and Control 80 module is respon-
sible for the following:

Monitoring and control of all the agents 36', 36'', 68, 70,
72, 74 associated with the Power and Lighting System
Coordinator 66.

Collection of information from the Data Filtering module
76. The type of information that this module will
collect is described under the Data Filtering module 76.
Analyzing the data from each agent, and filtering and
compiling the data into valid system scenarios.

Sending the valid system scenarios to the Machine Learn-
ing module 82 for predictions.

Receiving the predictions from the Machine Learning
module 82 and sending commands to the various agents
36', 36'', 68, 70, 72, 74. The commands that the System
Analysis and Control module 80 may send to the agents
36', 36'', 68, 70, 72, 74 could be battery storage
setpoints, energy use setpoints, requests for predictions,
or switching on and off various circuits within the
Lighting and Power Panelboards 68, 70.

Analyzing the scenarios proposed by the Scenario Gen-
erator module 84. For each scenario received, the
System Analysis and Control module 80 may decide to
direct the various agents 36', 36'', 68, 70, 72, 74 to make
predictions and then compile these predictions into
valid system scenarios for the Machine Learning mod-
ule 82 to make predictions on.

The Scenario Generator module **84** is responsible for continuously looking for ways to improve the overall energy performance of the entire power distribution system. For example, the Scenario Generator module **84** may create a series of scenarios which will then be sent to the System Analysis and Control module **80** to analyze and validate; the System Analysis and Control module **80** may ask the agents **36'**, **36"**, **68**, **70**, **72**, **74** to make predictions on the scenarios. Once the scenarios are validated, they may be sent to the Machine Learning module **82** to make predictions on. The predictions made by the Machine Learning module **82** will then be sent back to the Scenario Generator module **84** for analysis. After analyzing the predictions, the Scenario Generator module **84** may decide to send such predictions to SMITHGROUP-AI **10**, which in turn may direct the Power and Lighting System Coordinator **66** to implement one of the scenarios created by the Scenario Generator module **84**.

The Scenario Generator module **84** may create scenarios by modelling the Renewable Energy Agent **74** as delivering various power and by modelling the Zone Agents **36'**, **36"** as satisfying their zone power conditions under various conditions.

3. Panelboard Agents

a. Purpose

A panelboard agent is an independent software agent that monitor and controls all sensors and actuators associated with a Panelboard (e.g. Lighting Panelboard, Power Panelboard etc.). Each panelboard within the power distribution system is monitored and controlled by a dedicated Panelboard Agent **68**, **70**.

The panelboard agents **68**, **70** are responsible for the following:

Prediction of the energy use of each zone. The Panelboard Agents **68**, **70** will communicate, via the Power and Lighting System Coordinator **66**, with each zone such that its predictions are coordinated and validated based on the specific zone data and predictions.

Prediction of the energy use of the entire panelboard.

Communication with the Power and Lighting System Coordinator **66**. Sends panelboard energy use predictions (for the entire panelboard and for each zone) and receives commands from the Power and Lighting System Coordinator **66**.

b. Internal Structure

Referring to FIG. **6**, the internal structure of a Panelboard Agent **68** and its related environment is shown. The environment for the Panelboard Agent **68** is comprised of all the sensors **86**, **88**, **90**, **92**, **94**, **96** and actuators **98**, **100**, **102**, **104** that are located within a panelboard. In some instances, an open source non-proprietary input/output module or a gateway may be required to convert the signal from a sensor or an actuator such that it can be communicated via open source networks such as BACnet, LONworks, Modbus etc. The agent **68** is comprised of five modules, each with its own dedicated algorithms and controls logic.

The Data Filtering module **106** is responsible for separating the data received from sensors **86**, **88**, **90**, **92**, **94**, **96** and actuators **98**, **100**, **102**, **104**. For example, the actual energy consumption levels of each circuit may be sent to the System Feedback module **108**, while data (e.g. sensor or actuator status, etc.) will be sent to the System Analysis and Control module **110**. Further, zone data (e.g. predictions) received from the Power and Lighting System Coordinator **66** may be sent to the System Analysis and Control module **110**. The Data Filtering module **106** may also send to the System Analysis and Control module **110** the same data that was sent to the System Feedback module **108**. A sensor

within the panelboard may represent an electricity meter or a status signal from a circuit breaker. An actuator within the panelboard may represent a circuit breaker that can be commanded on or off.

The System Feedback module **108** is responsible for the following:

Collection of information from the various sensors **86**, **88**, **90**, **92**, **94**, **96** and actuators **98**, **100**, **102**, **104**. The type of information that the System Feedback module **108** may collect is described in the Data Filtering module **106**.

Analysis of predictions related to the energy level consumption levels for each zone. The data received from the various sensors **86**, **88**, **90**, **92**, **94**, **96** and actuators **98**, **100**, **102**, **104** will be compared against the predictions made by the Machine Learning module **112**. Any large discrepancies between the predicted and measured values could mean that the previous commands could indicate that the difference in the error or accuracy of the predictions made by the Machine Learning module **112** and the actual outcome might have exceeded critical limits, which in turn has affected the performance of the power system. The System Feedback module **108** will then send the measured values to the Machine Learning module **112** such that the Machine Learning module **112** can update its internal learning algorithms.

Collection of information from the Power and Lighting System Coordinator **66**. The information may represent feedback regarding the predictions that the Panelboard Agent **68** has made.

The Machine Learning module **112** is responsible for the following:

Collection of information from the System Feedback module **108**. The type of information that this module will collect is described under the System Feedback module **108**.

Collection of information from the System Analysis and Control module **110**. This information may represent data from the various sensors **86**, **88**, **90**, **92**, **94**, **96** and actuators **98**, **100**, **102**, **104**, such as airflows and associated temperatures.

Making predictions, using machine learning algorithms, based on the data received from the System Analysis and Control module **110** or from the System Feedback module **108**.

Sending the predictions to the System Analysis and Control module **110** and to the Scenario Generator module **114**.

The System Analysis and Control module **110** is responsible for the following:

Monitoring and control of all sensors **86**, **88**, **90**, **92**, **94**, **96** and actuators **98**, **100**, **102**, **104** related to the panelboard. Control of actuators **98**, **100**, **102**, **104** may represent switching on and off a circuit breaker, and thus power, associated with a specific Zone Agent. For example, a zone agent may predict that the power to the "switched" receptacles can be turned off at a specific time. The zone agent may communicate this event to the Power and Lighting System Coordinator **66**, which in turn may direct the Panelboard Agent **68** to switch off the associated circuit breaker.

Collection of information from the Data Filtering module **106**. The type of information that this module will collect is described under the Data Filtering module **106**.

Analyzing the data from each sensor and actuator. For example, the System Analysis and Control module **110** may determine that a zone is consuming significantly more energy than what was predicted (by both the Machine Learning module of the zone agent and by the Machine Learning module **112** of the Panelboard Agent **68**). As such, the System Analysis and Control module **110** may ask that specific zone agent, via the Power and Lighting System Coordinator **66**, to verify the accuracy of its sensors and predictions.

Analyzing the scenarios proposed by the Scenario Generator module **114**. For each scenario received, the System Analysis and Control module **110** will analyze the status of the sensors **86, 88, 90, 92, 94, 96** and actuators **98, 100, 102, 104** and will determine which scenario is valid. For example, one of the scenarios that the Scenario Generator module **114** may generate will require some of the zones to consume 15% less energy than usual. The System Analysis and Control module **110** may determine, after communication with the associated zone agents (via the Power and Lighting System Coordinator **66**), that such scenario is no longer valid and that the Machine Learning module **112** will not make a prediction on the referenced scenario.

The Scenario Generator module **114** is responsible for continuously looking for ways/scenarios to improve the overall energy performance of the power systems associated with it. For example, the Scenario Generator module **114** may create a series of scenarios that will then be sent to the System Analysis and Control module **110** to analyze and validate. Once the scenarios are validated, they may be sent to the various zone agents (for analysis and predictions), via the Power and Lighting System Coordinator **66**, or to the Machine Learning module **112** to make its own predictions. The predictions made by the Machine Learning module **112** will then be sent back to the Scenario Generator module **114** for analysis. After analyzing the predictions, the Scenario Generator module **114** may decide to send such predictions to the Power and Lighting System Coordinator **66**, which may send them to SMITHGROUP-AI **10**, which in turn may direct the Power and Lighting System Coordinator **66** to implement one of the scenarios created by the Scenario Generator module **66**.

The Scenario Generator module **114** may create scenarios by turning on and off various receptacle, lighting, and equipment circuits at a certain time. Each such scenario will have an impact on the energy performance of the power system and on the heating and cooling loads within a zone.

4. Renewable Energy Agent

a. Purpose

The Renewable Energy Agent **74** is an independent software agent that monitors and controls all renewable energy systems connected to the power distribution system. The control of wind turbines and solar panels, for example, is done through the manufacturer provided proprietary control panels. The control panels are connected to the network through integration via open source non-proprietary input/output modules or gateways. In some instances, the sensors and actuator associated with the wind turbine control systems and solar panel control systems may be connected directly to the network through non-proprietary input/output modules or gateways.

The sensors that the Renewable Energy Agent **74** may monitor are battery levels, status of solar panels, status of windmills, weather data, etc. The actuators that the Renew-

able Energy Agent **74** may control are turning on/off the renewable energy systems, various circuit breakers located in the distribution panel, etc.

The Renewable Energy Agent **74** is responsible for the following:

Prediction of the energy generation from the renewable systems.

Communication with the Power and Lighting System Coordinator **66**. It sends energy generation predictions and receives commands from the Power and Lighting System Coordinator **66**.

b. Internal Structure

Referring to FIG. 7, the internal structure of the Renewable Energy Agent **74** and its related environment is shown. The environment for the Renewable Energy Agent **74** is comprised of all the sensors **116, 118, 120, 122**, actuators **124, 126, 128, 130**, and renewable energy systems. The agent **74** is comprised of five modules, each with its own dedicated algorithms and control logic.

The Data Filtering module **132** is responsible for separating the data received from sensors **116, 118, 120, 122** and actuators **124, 126, 128, 130**. For example, the amount of stored or generated data will be sent to the System Feedback module **134**, while data from other various sensors (e.g. alarms, battery levels etc.) will be sent to the System Analysis and Control module **136**. The Data Filtering module **132** may also send to the System Analysis and Control module **136** the same data that was sent to the System Feedback module **134**.

The System Feedback module **134** is responsible for the following:

Collection of information from the various sensors **116, 118, 120, 122** and actuators **124, 126, 128, 130**. The type of information that the System Feedback module **134** may collect is described in the Data Filtering module **132**.

Analysis of predictions related to the energy generated or stored. The data received from the various sensors **116, 118, 120, 122** and actuators **124, 126, 128, 130** will be compared against the predictions made by the Machine Learning module **138**. Any large discrepancies between the predicted and measured values could mean that the previous commands could indicate that the difference in the error or accuracy of the predictions made by the Machine Learning module **138** and the actual outcome might have exceeded critical limits, which in turn has affected the overall energy and energy performance of the renewable energy system. The System Feedback module **134** will then send the measured values to the Machine Learning module **138** such that the Machine Learning module **138** can update its internal learning algorithms.

Collection of information from the Power and Lighting System Coordinator **66**. The information may represent feedback regarding the predictions that the Renewable Energy Agent **74** has made or regarding the commands that the Power and Lighting System Coordinator **66** might have previously sent. For example, the Machine Learning module **138** might have predicted that a certain amount of renewable energy will be available for use by the power systems. However, the actual amount of generated energy is greater than what was predicted. Once it detects this difference, the Power and Lighting System Coordinator **66** may command the Renewable Energy Agent **74** to improve its internal learning algorithms such that the error of its predictions is minimized to the greatest extent possible.

The Machine Learning module **138** is responsible for the following:

Collection of information from the System Feedback module **134**. The type of information that this module will collect is described under the System Feedback module **134**.

Collection of information from the System Analysis and Control module **136**. This information may represent data from the various sensors **116, 118, 120, 122** and actuators **124, 126, 128, 130**.

Making predictions, based on the data received from the System Analysis and Control module **136** or from the System Feedback module **134**. For example, the Machine Learning module **138**, using weather data and data from the renewable energy systems (e.g. generation capacity, storage capacity, etc.) may be able to predict the rate at which energy will be generated or stored by the renewable energy systems. Further, the Machine Learning module **138** may predict how much energy will be generated in the next hour, next day, week or month.

Sending the predictions to the System Analysis and Control module **136** and to the Scenario Generator module **140**.

The System Analysis and Control module **136** is responsible for the following:

Monitoring and control of all sensors **116, 118, 120, 122** and actuators **124, 126, 128, 130** related to the renewable energy systems.

Collection of information from the Data Filtering module **132**. The type of information that this module will collect is described under the Data Filtering module **132**.

Analyzing the data from each sensor and actuator. For example, the System Analysis and Control module **136** may determine that a solar panel or an array of solar panels is no longer capable of functioning as required. As such, the System Analysis and Control module **136** may need to send this feedback to the Machine Learning module **138** for predictions.

Analyzing the scenarios proposed by the Scenario Generator module **140**. For each scenario received, the System Analysis and Control module **136** will analyze the status of the sensors and actuators and will determine which scenario is valid. For example, one of the scenarios that the Scenario Generator module **140** may generate is to predict how much energy the renewable systems can generate if there are clear sky conditions and if 90% of the solar panels are not available for use. The System Analysis and Control module **136** may determine that, due to additional solar panel failures, such scenario is no longer valid and that the Machine Learning module **138** will not make a prediction on the referenced scenario.

The Scenario Generator module **140** is responsible for continuously looking for ways/scenarios to improve the overall energy performance renewable energy systems. For example, the Scenario Generator module **140** may create a series of scenarios that will then be sent to the System Analysis and Control module **136** to analyze and validate. Once the scenarios are validated, they may be sent to the Machine Learning module **138** to make predictions on. The predictions made by the Machine Learning module **138** will then be sent back to the Scenario Generator module **140** for analysis. After analyzing the predictions, the Scenario Generator module **140** may decide to send such predictions to the Power and Lighting System Coordinator **66**, which may

send them to SMITHGROUP-AI **10**, which in turn may direct the Power and Lighting System Coordinator **66** to implement one of the scenarios created by the Scenario Generator module **140**.

The Scenario Generator module **140** may create scenarios by simulating the amount of energy generated or stored by the renewable energy system, by simulating the demand that the power system is exercising on the renewable energy system, by simulating various outdoor conditions (e.g. cloudy sky, wind speeds, etc.), by simulating various rates of energy generation (e.g. how much kWh are being generated in the next 3 hours), or by simulating various system settings (e.g. angle and direction of the solar panels, direction of the windmill.)

5. Utility Agent

The Utility Agent's sole responsibility is to monitor the status of the utility power (e.g. loss of power) or receive information from the utility company to enter into demand response mode and notify the Power and Lighting System Coordinator **66** of such events.

D. AHU System

1. General Description

Referring to FIG. **8**, an airside system is shown as having one air handling unit **142** delivering a mixture of outside air and return air to five zones **144, 146, 148, 150, 152**. The control of the entire airside system is performed through a series of independent software agents such as the AHU System Coordinator **20**, AHU Agent **154**, and Zone Agents **156, 158, 160, 162, 164**.

FIG. **9** shows the communication architecture between the various airside system Agents. Considering the network architecture of the sensors and actuators associated with an AHU, all sensors and actuators are connected directly to the network, without the use of proprietary controllers that operate with programmed sequences of operation. In some instances, an open source non-proprietary input/output module or a gateway may be required to convert the signal from a sensor or an actuator such that it can be communicated via open source networks such as BACnet, LONworks, Modbus etc.

2. AHU System Coordinator

a. Purpose

The AHU System Coordinator **20** is an independent software agent that monitors and controls all agents **154, 156, 158, 160, 162, 164** associated with its respective airside system. Further, the AHU System Coordinator **20** is responsible for the following:

Prediction of the energy use of the entire airside system.

Communication with SMITHGROUP-A **10**. It sends overall airside system energy use predictions and receives commands from SMITHGROUP-AI **10**.

Communication with the AHU Agent **154**. It requests energy consumption predictions and status from the AHU Agent **154** and sends predictions (e.g. total system supply airflow, total system return air flow, total system outside airflow) such that the AHU Agent **154** can make associated predictions related to the energy performance of the AHU **142**.

Communication with the Hot Water System Coordinator **18** and the Chilled Water System Coordinator **16**. The type of information that the AHU System Coordinator **20** communicates to the Hot Water System Coordinator **18** and the Chilled Water System Coordinator **16** may represent cooling load and heating load predictions from each Zone Agent **156, 158, 160, 162, 164** and AHU agent **154**.

b. Internal Structure

Referring to FIG. 10, the internal structure of the AHU System Coordinator 20 and its related environment is shown. The environment for the AHU System Coordinator 20 is comprised of all the agents that it monitors and controls. The agent is comprised of five modules, each with its own dedicated algorithms and control logic.

The Data Filtering module 166 is responsible for separating the data received from the various agents 154, 156, 158, 160, 162, 164. For example, the actual agent energy consumption levels or actual agent airflows will be sent to the System Feedback module 168, while predictions from the agents 154, 156, 158, 160, 162, 164 will be sent to the System Analysis and Control module 170.

The System Feedback module 168 is responsible for the following:

Collection of information from the Zone Agents 156, 158, 160, 162, 164 and AHU Agent 154. The information may represent status (e.g. failed, maintenance), or actual agent energy consumptions levels from the various agents. A failed status may indicate that a Zone Agent 156, 158, 160, 162, 164 or an AHU Agent 154 no longer controls its environment and should be excluded from the overall airside system predictions that the Machine Learning module 172 is making. A maintenance status may indicate that a Zone Agent 156, 158, 160, 162, 164 or an AHU Agent 154 has entered or may enter into a maintenance mode and that the Machine Learning module 172 needs to update its overall airside system predictions accordingly. The information may also represent predictions related to the energy consumption levels of each agent.

Analysis of predictions related to the total airside system airflow. The actual airflows from the various agents 154, 156, 158, 160, 162, 164 will be compared against their own predictions but also against the predictions made by the Machine Learning module 172. Any large discrepancies between the predicted and actual airflows could mean that the previous command that a Zone Agent 156, 158, 160, 162, 164 or AHU agent 154 received from the AHU System Coordinator 20 has placed a Zone Agent 156, 158, 160, 162, 164 or AHU agent 154 in conflict with its own internal laws (e.g. not able to meet the various zone thermal requirements). This could indicate that the difference in the error or accuracy of the predictions made by the Machine Learning module 172 and the actual outcome might have exceeded critical limits, which in turn has affected the overall energy and thermal performance of the airside system. The System Feedback module 168 will then send the actual airflows to the Machine Learning module 172 such that the Machine Learning module 172 can update its internal learning algorithms.

Collection of information from SMITHGROUP-AI 10: the information may represent commands that need to be distributed to the various associated Zone Agents 154, 156, 158, 160, 162, 164 and AHU agents 154. The information may also represent feedback regarding the predictions that the AHU System Coordinator 20 has made: for example, the predicted energy performance of the Scenario that SMITHGROUP-AI 10 has directed

the AHU System Coordinator 20 to implement is significantly different than the real outcome. As such the System Feedback module 168 will pass this feedback to the Machine Learning module 172 to update its machine learning algorithms accordingly such that the accuracy or error of its predictions self-improves.

The Machine Learning module 172 is responsible for the following:

Collection of information from the System Feedback module 168. The type of information that this module will collect is described under the System Feedback module 168.

collection of information from the System Analysis and Control module 170. This information may represent predictions from Zone Agents 156, 158, 160, 162, 164 and AHU agent 154 regarding airflows, temperature, cooling loads, heating loads, etc.

Making predictions, using machine learning algorithms, based on the data received from the System Analysis and Control module 170, for the overall energy consumption of the entire airside system or for the total airflow that the AHU agent 154 will need to deliver.

Sending the predictions to the System Analysis and Control module 170 and to the Scenario Generator module 174.

The System Analysis and Control module 170 is responsible for the following:

Collection of information from the Data Filtering module 166. The type of information that this module will collect is described under the Data Filtering module 166.

Analyzing the data from each agent, and filtering and compiling the data into valid system scenarios. A more detailed description of this process is presented in the Sample Process paragraph.

Sending the valid system scenarios to the Machine Learning module 172 for predictions.

Receiving the predictions from the Machine Learning module 172 and sending commands to the various agents 154, 156, 158, 160, 162, 164. The commands that the System Analysis and Control module 170 may send to the agents could be airflow setpoints, temperature setpoints or requests for predictions.

Analyzing the scenarios proposed by the Scenario Generator module 174. For each scenario received, the System Analysis and Control module 170 may decide to direct the various agents to make predictions and then compile these predictions into valid system scenarios for the Machine Learning module 172 to make predictions on.

The Scenario Generator module 174 is responsible for continuously looking for ways to improve the overall energy performance of the entire airside system. For example, the Scenario Generator module 174 may create a series of scenarios that will then be sent to the System Analysis and Control module 170 to analyze and validate. The System Analysis and Control module 170 may ask the agents to make predictions on the scenarios. Once the scenarios are validated, they may be sent to the Machine Learning module 172 to make predictions on. The predictions made by the Machine Learning module 172 will then be sent back to the

Scenario Generator module **174** for analysis. After analyzing the predictions, the Scenario Generator module **174** may decide to send such predictions to SMITHGROUP-AI **10**, which in turn may direct the AHU System Coordinator **20** to implement one of the scenarios created by the Scenario Generator module **174**.

The Scenario Generator module **174** may create scenarios by modelling the AHU Agent **154** as delivering various airflows and various temperatures and by modelling the Zone Agents **156, 158, 160, 162, 164** as satisfying their zone thermal load conditions under various conditions.

c. Sample Process

Each Zone Agent **156, 158, 160, 162, 164** will send to the AHU System Coordinator **20** a series of predictions and status information. The predictions that each Zone Agent **156, 158, 160, 162, 164** will send to the AHU System Coordinator **20** are related to the airflow requirements and various temperatures that the Zone Agent could use to satisfy its zone requirements. Further, each Zone Agent **156, 158, 160, 162, 164** will send to the AHU System Coordinator **20** the associated zone predictions for the Hot Water System Coordinator **18** and for the Chilled Water System Coordinator **16**.

The System Analysis and Control module **170** will first compile all airside system related predictions from the Zone Agents **156, 158, 160, 162, 164**. The System Analysis and Control module **170**, based on the laws of each Zone Agent **156, 158, 160, 162, 164**, will then eliminate any zone agent predictions that will make other zone agents incapable of meeting their internal laws. The System Analysis and Con-

supply airflow, return airflow return air temperature, and outside airflow. For example, by analyzing the various zone ventilation efficiencies and the outside air-dry bulb temperature and relative humidity, the Machine Learning module **172** may predict that an air side economizer (e.g. an artificial increase in outside air flow) is better suited than delivering the lowest required amount of outside air flow. The Machine Learning module **172** will send these predictions back to the System Analysis and Control module **170**, which in turn will send them to the AHU Agent **154** to make its own predictions regarding AHU energy consumption. Once it receives the predictions from the AHU Agent **154**, it will then send the overall airside system predictions to SMITHGROUP-AI **10** and the associated Zone Agent and AHU agent load predictions to the Hot Water System Coordinator **18** and the Chilled Water System Coordinator **16**. The AHU System Coordinator **20** will send to the Hot Water System Coordinator **18** only the zone agent predicted heating loads that correspond to valid scenarios analyzed by the System Analysis and Control module **170**. The AHU System Coordinator **20** will send to the Chilled Water System Coordinator **16** only the AHU Agent predicted cooling loads that correspond to total system airflow predictions performed by the Machine Learning module **172**.

In further detail, each zone agent creates a series of scenarios associated with the zone that it is serving and sends these scenarios to a System Coordinator (e.g. AHU System Coordinator **20**). These scenarios are given a unique ID number (Table 1 below) based on a specific airflow supply air temperature (SAT) and a specific entering water temperature (EWT).

TABLE 1

Zone Agent 1							
Zone Prediction ID	Zone Data		Predictions				
	Zone Load Btu/Hr	Temperature Setpoint 0F	Coil EAT 0F	Dew Point DP 0F	Primary Zone Airflow CFM	Outdoor Air Fraction Zp	Energy Predictions kWh
Agent_1-1	20000	72	50	48	1000	0.76	0.10
Agent_1-2	20000	72	51	49	1200	0.92	0.36
Agent_1-3	20000	72	52	50	1400	0.95	0.37
Agent_1-4	20000	72	53	51	1600	0.67	0.43
Agent_1-5	20000	72	54	52	1800	0.81	0.18
Agent_1-6	20000	72	55	53	2000	0.91	0.40
Agent_1-7	20000	72	56	54	2200	0.78	0.39
Agent_1-8	20000	72	57	55	2400	0.70	0.24
Agent_1-9	20000	72	58	56	2600	0.68	0.29
Agent_1-10	20000	72	59	57	2800	0.81	0.12

trol module **170** will then compile and sort all valid predictions made by the Zone Agents **156, 158, 160, 162, 164**. For example, as a first step, the System Analysis and Control module **170** may sort the predictions based on a common AHU discharge air temperature. In a second step, the System Analysis and Control module may then choose the lowest dew point temperature required by a Zone Agent **156, 158, 160, 162, 164**. The System Analysis and Control module **170** will then establish a series of valid airside system scenarios. These scenarios will then be sent to the Machine Learning module **172** to make predictions regarding the total system

The AHU System Coordinator **20** then filters/validates the scenarios received from the zone agents (Table 2 below). The validation process could be based on the physical limitation of the air handling unit. In some instances, even though a zone may be able to be cooled with a very cold air temperature (e.g. 50° F.), due the operating conditions at that time or physical limitations of the internal components of the air handling unit, the air handling unit may not be able to cool the air to 50° F. As such the AHU System Coordinator **20** may label the associated scenarios as invalid (in bold below).

TABLE 2

Zone Agent 1							
		Predictions					
Zone Data		Dew		Primary			
Zone Prediction ID	Zone Load BTU/Hr	Temperature Setpoint OF	Coil EAT OF	Point DP OF	Zone Airflow CFM	Outdoor Air Fraction Zp	Energy Prediction kWh
Agent_1-1	2000	72	50	48	1000	.76	.10
Agent_1-2	2000	72	51	49	1200	.92	.36
Agent_1-3	2000	72	52	50	1400	.95	.37
Agent_1-4	2000	72	53	51	1600	.67	.43
Agent_1-5	2000	72	54	52	1800	.81	.18
Agent_1-6	2000	72	55	53	2000	.91	.40
Agent_1-7	2000	72	56	54	2200	.78	.39
Agent_1-8	2000	72	57	55	2400	.70	.24
Agent_1-9	2000	72	58	56	2600	.68	.29
Agent_1-10	2000	72	59	57	2800	.81	.12

20

The AHU System Coordinator **20** will then start creating combinations of agent scenarios (Table 3 below). Each combination of scenarios is then given a unique ID number (e.g. AHU_1-1). For each combination of agent scenarios there is a corresponding set of air handling unit conditions that need to be achieved (e.g. total airflow, coil dew point, etc.).

TABLE 3

AHU-1 System Predictions							
		Zone Predictions					
System Identification Data		Dew		Primary Outdoor			
AHU System Scenario ID	Zone Prediction ID	Temperature Setpoint OF	Coil EAT OF	Point DP OF	Zone Airflow CFM	Air Fraction Zp	Energy Predictions kWh
AHU_1-1	Agent_1-3	72	52	50	1400	0.95	0.37
	Agent_2-3	70	52	50	700	0.95	0.37
	Agent_3-1	73	52	48	300	0.76	0.10
	Agent_4-3	71	52	50	1200	0.95	0.37
	Agent_5-3	75	52	50	1400	0.95	0.37
Totals					5000		

The AHU System Coordinator **20** will then send these combinations of agent scenarios (Table 4 below) to the AHU Agent **154** to make predictions on the total system supply airflow, return airflow, and outside air flow.

TABLE 4

AHU-1 SYSTEM PREDICTIONS							
AHU SYSTEM SCENARIOS			PREDICTIONS				
AHU System Prediction ID	Supply Air Temperature SAT OF	Dew Point DP OF	Total Zone Supply Airflow CFM	Total System Supply Airflow CFM	Total System Return Airflow CFM	System Return Air Temperature OF	Outside Airflow CFM
AHU_1-1	52	48	5000	5300	4900	71	1000
AHU_1-2	53	49	5700	5700	5000	73	2000
AHU_1-3	54	50	6400	6900	6000	75	3000
AHU_1-4	55	51	7100	7800	7000	74	4000

After receiving the predictions from the AHU agent **154**, the AHU System Coordinator **20** will then make predictions on the overall energy consumption levels for each combination of agent scenarios (Table 5 below) and will send these predictions to SMITHGROUP-AI **10**.

TABLE 5

AHU-1 AGENT PREDICTIONS							
AHU-1 SYSTEM SCENARIOS		RECEIVED DATA					PREDICTION
		Total	Total	System			
AHU System Prediction ID	Supply Air Temperature SAT OF	Dew Point DP OF	System Supply Airflow CFM	System Return Airflow CFM	System Return Air Temperature OF	Outside Airflow CFM	AHU-1 Energy Consumption kWh
AHU_1-1	52	48	5300	4900	71	1000	10
AHU_1-2	53	49	5700	5000	73	2000	15
AHU_1-3	54	50	6900	6000	75	3000	20
AHU_1-4	55	51	7800	7000	74	4000	25

3. AHU Agent

a. Purpose

The AHU Agent **154** is an independent software agent that monitors and controls all sensors and actuators associated with an AHU. Each AHU is controlled and monitored by a dedicated AHU Agent. Further, the AHU Agent **154** is responsible for the following:

- Prediction of the energy use of the entire airside system.
- Prediction of the required heating coil loads and cooling coil loads.
- Prediction of the air pressure drop through each of the AHU components.
- Prediction of the supply fan array energy consumption.
- Prediction of the return fan array energy consumption.
- Communication with the AHU System Coordinator **20**. It sends overall AHU energy use predictions and receives commands from the AHU System Coordinator **20**.

b. Internal Structure

Referring to FIG. **11**, the internal structure of the AHU Agent **154** and its related environment is shown. The environment for the AHU Agent **154** is comprised of the sensors **176, 178, 180, 182** and actuators **184, 186, 188, 190** that are used to monitor and control the AHU **142**. The agent **154** is comprised of five modules, each with its own dedicated algorithms and control logic.

The Data Filtering **192** module is responsible for separating the data received from sensors **176, 178, 180, 182** and actuators **184, 186, 188, 190**. For example, the energy consumption levels of fans (measured by their related Variable Frequency Drives (VFD)), actual fan airflows (measured by the associated airflow stations), or various temperatures (e.g. cooling coil leaving air temperature, unit leaving air temperature, etc.) will be sent to the System Feedback module **194**, while data from other various sensors (e.g. alarms, temperatures, etc.) will be sent to the System Analysis and Control module **196**. The Data Filtering module **192** may also send to the System Analysis and Control module **196** the same data that was sent to the System Feedback module **194**.

The System Feedback **194** module is responsible for the following:

- Collection of information from the various sensors and actuators. The type of information that the System Feedback module **194** may collect is described in the Data Filtering module **192**.

Analysis of predictions related to various temperatures (e.g. mixed air temperatures, coil leaving air temperature, unit leaving air temperature, etc.). The data received from the various sensors **176, 178, 180, 182** and actuators **184, 186, 188, 190** will be compared

against the predictions made by the Machine Learning module **198**. Any large discrepancies between the predicted and measured values could mean that the previous commands could indicate that the difference in the error or accuracy of the predictions made by the Machine Learning module **198** and the actual outcome might have exceeded critical limits, which in turn has affected the overall energy and energy performance of the air handling unit **142**. The System Feedback module **194** will then send the measured values to the Machine Learning module **198** such that the Machine Learning module **198** can update its internal learning algorithms. Collection of information from the AHU System Coordinator **20**. The information may represent feedback regarding the predictions that the AHU Agent **154** has made. For example, the AHU **142** might deliver a certain amount of supply air to the Zones **144, 146, 148, 150, 152** and at the same time its internal airflow sensors are confirming that the measured supply airflow is equal to or close to what was predicted. However, some zones, as measured by the sensors of the Zone Agents **156, 158, 160, 162, 164** might not receive sufficient airflow. This could be indication that the AHU airflow sensors are defective or that they might need recalibration.

The Machine Learning module **198** is responsible for the following:

- Collection of information from the System Feedback module **194**. The type of information that this module will collect is described under the System Feedback module **194**.
- Collection of information from the System Analysis and Control module **196**. This information may represent data from the various sensors **176, 178, 180, 182** and actuators **184, 186, 188, 190**, such as airflows and associated temperatures.
- Making predictions, using machine learning algorithms, based on the data received from the System Analysis and Control module **196** or from the System Feedback module **194**.
- Sending the predictions to the System Analysis and Control module **196** and to the Scenario Generator module **200**.

For each component (e.g. coil, filter bank, fans, etc.) of the AHU **142**, the Machine Learning module **198** will use

various machine learning algorithms to predict its performance (e.g. Btu/hr, leaving water temperature, water flow, etc.), air pressure drop, energy consumption (e.g. kWh). For example, a coil has fixed properties (e.g. width, height, number of fins, tube diameter, etc.). As such, a machine learning algorithm may be trained, via the use of manufacturer's rated coil performance data at various conditions (e.g. various entering air temperatures, entering water temperatures and flow), to predict what the coil leaving air temperature and water temperature may be at other conditions not included in the training data set.

Similarly, using fan laws and manufacturer's rated fan performance data as a training set, a machine learning algorithm may be trained to predict what the fan energy consumption will be at various system conditions (e.g. various airflows and various associated fan static pressures). Once released into the real environment, the Machine Learning module **198**, via the feedback received from the System Feedback module **194**, may update its internal machine learning algorithms and related predictions (e.g. fan motor energy consumption, static pressure setpoints, etc.) to account for system effects and for the measurement errors of the various sensors.

Using an approach similar to the above, the Machine Learning module **198** may also use each individual component prediction as a data set and/or training set to make predictions for the energy consumption of the entire AHU **142**. For example, the Machine Learning module **194** may build a training set comprised of the supply fan airflow, return fan airflow, return static pressure, supply static pressure, and associated fan motor energy consumption. Once the training set is of considerable size, the Machine Learning module **198** may use it to predict fan motor energy consumption on new data that is not a part of the training set.

The Machine Learning module **198** may also inform the System Analysis and Control module **196** on what coil (e.g. preheat coil or cooling coil) can be used for preheating. For example, the Machine Learning module **198**, using various sensors (e.g. return air and outside temperature sensors), may predict that the mixed air temperature resulted from the mixing of the return air flow and outside airflow is 37°F, while the required AHU supply air temperature is 52° F. A typical approach would be to enable the preheat coil to warm up the mixed air around 50° F., and then, by picking up the heat from the fan motors, the AHU supply air temperature will be 52° F. However, the Machine Learning module **198**, by analyzing the properties of the cooling coil and the related chilled water temperatures and flow, may predict that the preheat coil is required to only preheat the mixed air to 47° F. and then the chilled water coil can be used to preheat the air to 50° F. In the case when preheating is not required, the Machine Learning module **198** may predict that an artificial increase in the amount of outside air that the AHU **142** is delivering may lower the mixed air return air temperature enough to require preheating using the cooling coil. This approach may result in significant energy savings for both the AHU **142** and the Chilled Water Plant. The predictions described above will then be sent to the AHU System Coordinator **20**, which in turn will send the predictions to the Chilled Water System Coordinator **16**. See Chilled Water System Coordinator description for additional information.

The System Analysis and Control module **196** is responsible for the following:

Monitoring and control of all sensors and actuators related to the AHU **142**.

Collection of information from the Data Filtering module **192**. The type of information that this module will collect is described under the Data Filtering module **192**.

Analyzing the data from each sensor and actuator. For example, the System Analysis and Control module **196** may determine that a fan is no longer capable of running (e.g. the motor has burned out). As such, the System Analysis and Control module **196** may need to update its valid scenario (e.g. how many fans need to operate and at what speed) to deliver the required amount of airflow to the Zones **144, 146, 148, 150, 152**.

Sending the valid system scenarios to the Machine Learning module **198** for predictions.

Receiving the predictions from the Machine Learning module **198** and sending commands to the various actuators **184, 186, 188, 190**. The commands that the System Analysis and Control module **196** may send to the actuators **184, 186, 188, 190** could be valve position, damper position or fan speed.

Analyzing the scenarios proposed by the Scenario Generator module **200**. For each scenario received, the System Analysis and Control module **196** will analyze the status of the current sensors **176, 178, 180, 182** and actuators **184, 186, 188, 190** and will determine which scenario is valid. For example, one of the scenarios that the Scenario Generator module **200** may generate, will require the AHU **142** to deliver 10,000 cfm to the Zones **144, 146, 148, 150, 152**. The System Analysis and Control module **196** may determine that, due to a fan failure, such scenario is no longer valid and that the Machine Learning module **198** will not make a prediction on the referenced scenario.

The Scenario Generator module **200** is responsible for continuously looking for ways/scenarios to improve the overall energy performance of the AHU **142**. For example, the Scenario Generator module **200** may create a series of scenarios which will then be sent to the System Analysis and Control module **196** to analyze and validate. Once the scenarios are validated, they may be sent to the Machine Learning module **198** to make predictions on. The predictions made by the Machine Learning module **198** will then be sent back to the Scenario Generator module **200** for analysis. After analyzing the predictions, the Scenario Generator module **200** may decide to send such predictions to the AHU System Coordinator **20**, which may send them to SMITHGROUP-AI **10**, which in turn may direct the AHU System Coordinator **20** to implement one of the scenarios created by the Scenario Generator module **200**.

The Scenario Generator module **200** may create scenarios by varying the AHU air flows (e.g. outside air flow, return airflow, etc.) and related temperatures. Each such scenario will have an impact on the energy performance of fan motors and on the AHU coil heating and cooling loads.

E. Heating Hot Water System

1. General Description

FIG. **12** represents the Heating Plant **202** providing heating hot water to one Air Handling Unit **204** and seven thermal zones **206, 208, 210, 212, 214, 216, 218**. The control of the entire hot water system is performed through a series of independent software agents such as the Hot Water System Coordinator **18**, Heating Plant Agent **220**, and Zone Agents **222, 224, 226**. The communication architecture between the various agents and coordinators is shown in FIG. **13**.

2. Hot Water System Coordinator

a. Purpose

The Hot Water System Coordinator **18** is an independent software agent that monitors and controls all agents associated with its respective heating system. By coordinating and predicting the energy usage of the entire heating system, the Hot Water System Coordinator **18** will inform SMITHGROUP-AI **10** with the necessary information for it to optimize the overall building energy use.

The Hot Water System Coordinator **18** is responsible, but not limited to the following:

Satisfy and maintain all building heating loads requirements.

Optimize the energy use of the heating system.

Predict the energy use of the heating system.

Communication with SMITHGROUP-AI **10**. It sends overall heating system energy use predictions and receives commands from SMITHGROUP-AI **10**.

Communication with the Hot Water Plant Agent **220**. It requests energy consumption predictions and status from the Hot Water Plant Agent **220** and sends predictions (e.g. total heating hot water system water flow, heating hot water supply temperature, heating hot water return temperature) such that the Heating Plant Agent **220** can make associated predictions related to the energy performance of the Heating Water Plant **220**.

b. Internal Structure

FIG. **14** represents the internal structure of the Hot Water System (HWS) Coordinator **18** and its environment. The environment of the HWS Coordinator **18** is comprised of all agents **222, 224, 226, 228, 230, 232, 234, 236** that it monitors and controls. The agents that the HWS Coordinator **18** controls are all zones and AHUs that contain a hot water coil and require hot water from the heating plant. The agent is comprised of five unique modules that have its own dedicated algorithm.

The Data Filtering module **238** is responsible for separating the data received from the various associated agents **222, 224, 226, 228, 230, 232, 234, 236**. For example, the actual agent energy consumption levels or actual agent hot water flow may be sent to the System Feedback module **240**, while predictions from the agents will be sent to the System Analysis and Control module **242**.

The System Feedback module **240** is responsible for the following:

Collection of information from the Zone Agents **222, 224, 226, 228, 230, 232, 234** and the Heating Plant Agent **220**, the information may represent status (e.g. failed, maintenance), or actual agent energy consumptions levels from the various agents. A failed status may indicate that a Zone Agent **222, 224, 226, 228, 230, 232, 234** may no longer control its environment and should be excluded from the overall condenser water system predictions that the Machine Learning module **244** is making. A maintenance status may indicate that a Zone Agent **222, 224, 226, 228, 230, 232, 234** has entered or may enter into a maintenance mode and that the Machine Learning module **244** needs to update its overall chilled water system predictions accordingly. The information may also represent predictions related to the energy consumption levels of each agent.

Analysis of predictions related to the total heating hot water flow. The actual heating hot water flow from the various agents will be compared against their own predictions but also against the predictions made by the Machine Learning module **244**. Any large discrepancies between the predicted and actual heating hot water

flows could mean that the previous command that a Zone Agent **222, 224, 226, 228, 230, 232, 234** or the Heating Plant Agent **220** received from the Hot Water System Coordinator **18** has placed an Agent **222, 224, 226, 228, 230, 232, 234, 236** in conflict with its own internal laws (e.g. not able to meet the various zone thermal requirements or expected chilled water system flow). This could indicate that the difference in the error or accuracy of the predictions made by the Machine Learning module **244** and the actual outcome might have exceeded critical limits, which in turn has affected the overall energy and thermal performance of the heating system. The System Feedback module **240** will then send the actual chilled water flows to the Machine Learning module **244** such that the Machine Learning module **244** can update its internal learning algorithms. Collection of information from SMITHGROUP-AI **10**. The information may represent commands that need to be distributed to the various associated Agents. The information may also represent feedback regarding the predictions that the Hot Water System Coordinator **18** has made; for example, the predicted energy performance of the Scenario that SMITHGROUP-AI **10** has directed the Hot Water System Coordinator **10** to implement is significantly different than the real outcome. As such the System Feedback module **240** will pass this feedback to the Machine Learning module **244** to update its machine learning algorithms accordingly such that the accuracy or error of its predictions self-improves.

The Machine Learning module **244** will be responsible for the following:

Collect information from the Data Filtering **238** and System Analysis and Control module **242**.

Predict the overall energy consumption of the entire Hot Water System or for the total water flow that the Heating Plant Agent **220** must deliver based on the data received from the System Analysis and Control module **242**.

Send predictions back to the System Analysis and Control module **242** and to the Scenario Generator module **246**.

The System Analysis and Control module **242** is responsible for the following:

Collect information from the Data Filtering module **238**. The type of information that this module may collect is described under the Data Filter module **238**.

Analyze data received from each agent, and filtering and compiling the data into valid system scenarios. A more detailed description of this process is presented in the sample process.

Send valid system scenarios to the Machine Learning module **244** for predictions.

Receiving the predictions from the Machine Learning module **244** and send commands to the various agents. The commands that the System Analysis and Control module **242** may send to the agents **222, 224, 226, 228, 230, 232, 234, 236** could be chilled water entering and leaving setpoints, heating hot water flows, or requests for predictions.

Analyzing the scenarios proposed by the Scenario Generator module **246**. For each scenario received, the System Analysis and Control module **242** may decide to direct the various agents to make predictions and then compile these predictions into valid system scenarios for the Machine Learning module **244** to make predictions on.

The Scenario Generator module **246** is responsible for continuously looking for ways to improve the overall energy performance of the entire heating hot water system. For example, the Scenario Generator module **246** may create a series of scenarios which will then be sent to the System Analysis and Control module **242** to analyze and validate. The System Analysis and Control module **242** may ask the associated agents to make predictions on the scenarios. Once the scenarios are validated, they may be sent to the Machine Learning module **244** to make predictions on. The predictions made by the Machine Learning module **244** will then be sent back to the Scenario Generator module **246** for analysis. After analyzing the predictions, the Scenario Generator module **246** may decide to send such predictions to SMITHGROUP-AI **10**, which in turn may direct the Hot Water System Coordinator **18** to implement one of the scenarios created by the Scenario Generator module **246**.

The Scenario Generator module **246** may create scenarios by modelling the Heating Plant Agent **220** as delivering various heating hot water flows and associated temperatures and by modelling the Zone Agents **222, 224, 226, 228, 230, 232, 234** or AHU agents **236** as satisfying their load conditions under various conditions.

3. Heating Plant Agent

a. Purpose

The Heating Plant Agent **220** is an independent agent that monitors and controls all sensors **248, 250, 252, 254** and actuators **256, 258, 260, 262**, associated with the Heating Plant **202**. Further, the Heating Plant Agent **220** is responsible for the following:

- Prediction of the energy use of the entire heating plant.

- Prediction of the boiler's energy consumption.

- Prediction of firing rates of each boiler.

- Prediction of the hot water pumps energy consumption.

- Prediction of the water pressure drop through each of the hot water system piping components (e.g. control valve, heat exchanger, coil).

- Communication with the Hot Water System Coordinator **18**. It receives valid scenario predictions (e.g. total hot water coil loads, hot water supply temperature, hot water return temperature, total hot water flow) such that the hot water agent can make associated energy predictions to send back to the Hot Water System Coordinator **18**.

b. Internal Structure

As shown in FIG. **15** the internal structure of the Heating Plant Agent **220** includes five modules: Data Filtering **264**, System Feedback **266**, Machine Learning **268**, System Analysis and Controls **270**, and Scenario Generators **272**. The environment for the Heating Plant Agent **220** is comprised of all the sensors **248, 250, 252, 254** and actuators **256, 258, 260, 262** of the equipment that it monitors and controls. The sensors **248, 250, 252, 254** and actuators **256, 258, 260, 262** that are part of the Heating Plant Agent's environment are connected directly to the network, without the use of proprietary controllers that operate with programmed sequences of operation. In some instances, an open source non-proprietary input/output module or a gateway may be required to convert the signal from a sensor or an actuator such that it can be communicated via open source networks such as BACnet, LONworks, Modbus etc.

The Data Filtering module **264** is responsible for separating the data received from the sensors **248, 250, 252, 254** and actuators **256, 258, 260, 262**. For instance, the energy consumption levels of the hot water pumps (measured by the Variable Frequency Drives (VFD)), actual heating hot water flows (measured by the associated flow meters), actual

natural gas consumption (measured by the associated boiler natural gas flow meters), or the actual plant hot water return temperature may be sent to the System Feedback module **266**. Other data such as status and alarms may be sent to the System Analysis and Control module **270**. The Data Filtering module **264** may also send to the System Analysis and Control module **270** the same data that was sent to the System Feedback module **266**.

The System Feedback module **266** is tasked with the following:

- Collection of information from the various sensors **248, 250, 252, 254** and actuators **256, 258, 260, 262**. The type of information that the System Feedback module **266** may collect is described in the Data Filtering module **264**.

- Analysis of predictions related to various temperatures (e.g. plant heating hot water leaving temperature, plant heating hot water return temperature, etc.). The data received from the various sensors **248, 250, 252, 254** and actuators **256, 258, 260, 262** will be compared against the predictions made by the Machine Learning module **268**. Any large discrepancies between the predicted and measured values could mean that the previous commands could indicate that the difference in the error or accuracy of the predictions made by the Machine Learning module **268** and the actual outcome might have exceeded critical limits, which in turn has affected the overall energy and energy performance of the heating plant. The System Feedback module **266** will then send the measured values to the Machine Learning module **268** such that the Machine Learning module **268** can update its internal learning algorithms.

- Collection of information from the Hot Water System Coordinator **18**. The information may represent feedback regarding the predictions that the Heating Plant Agent **220** has made. For example, the heating plant **202** might deliver a certain heating hot water flow to the Zones **206, 208, 210, 212, 214, 216, 218** or to the AHUs **204** in the same time its internal flow meters are confirming that the measured heating hot water flow is equal to or close to what was predicted. However, some Zones **206, 208, 210, 212, 214, 216, 218** or AHUs **204**, as measured by their associated flow meters, might not receive sufficient heating hot water; this could be indication that the plant heating hot water flow meters are defective or that they may need recalibration.

The Machine Learning module **268** is tasked with the following:

- Collect information from the Data Filtering **264** and System Analysis and Control module **270**.

- Predict the overall energy consumption of the entire heating plant or the total heating hot water flow that the Heating Plant Agent **220** will need to deliver based on the data received from the System Analysis and Control module **270**.

- Send the predictions back to the System Analysis and Control module **270** and to the Scenario Generator module **272**.

- Predict heating energy consumption, leaving water temperature, water flows for each major component (e.g. boiler, pumps etc).

Using manufacturers rated boiler performance and boiler curves data as a training set, a machine learning algorithm may be trained to predict the boiler energy consumption at various system conditions (e.g. entering and leaving hot water temperatures, hot water flows etc.). Once released into the real environment, the Machine Learning module **268**, via

the feedback received from the System Feedback module **266**, may update its internal machine learning algorithms and related predictions to account for system effects and the measurement errors of the various sensors.

Pump data will also be updated similarly. Using pump laws and manufacturer's rated pump performance data as a training set, a machine learning algorithm may be trained to predict what the pump energy consumption will be at various system conditions, water flow, and pump head conditions. Once released into the environment, the Machine Learning module **268** will update its internal machine learning algorithms and related predictions (e.g. pump motor energy consumption, pump differential sensor pressure set-points, etc.) based on the feedback received from the System Feedback module **266**.

Using an approach similar to the above, the Machine Learning module **268** may also use each individual component prediction as a data set and/or training set to make predictions for the energy consumption of the entire heating plant. For example, the Machine Learning module **268** may build a training set comprised of the plant heating hot water flow, plant entering heating hot water temperature, plant leaving heating hot water temperature, pump head and associated pump motor energy consumption. Once the training set is of useful size, the Machine Learning module **268** may use it to predict pump motor energy consumption on new data that is not a part of the training set.

The Machine Learning module **268** may use the training sets described above to operate the heating plant as efficiently as possible. The Machine Learning Module **268** may predict the entering water temperatures, leaving water temperatures, hot water flow, quantity of boilers, quantity and speed of pumps required to operate to satisfy building loads based on the predictions received from the Hot Water System Coordinator **18**.

The System Analysis and Control module **270** is responsible for the following:

Monitoring and control of all sensors and actuators related to the hot water system.

Collection of information from the Data Filtering module **264**. The type of information that this module will collect is described under the Data Filtering module **264**.

Analyzing the data from each sensor and actuator. For example, the System Analysis and Control module **270** may determine that a pump is no longer capable of running (e.g. the motor has burned out). As such, the System Analysis and Control module **270** may need to update its valid scenario (e.g. how many pumps need to operate and at what speed) to deliver the required amount of water flow to the zones.

Sending the valid system scenarios to the Machine Learning module **268** for predictions.

Receiving the predictions from the Machine Learning module **268** and sending commands to the various actuators. The commands that the System Analysis and Control module **270** may send to the actuators could be valve position, damper position or fan speed.

Analyzing the scenarios proposed by the Scenario Generator module **272**. For each scenario received, the System Analysis and Control module **270** will analyze the status of the current sensors and actuators and will determine which scenario is valid.

The Scenario Generator module **272** is responsible for continuously looking for ways/scenarios to improve the overall energy performance of the heating system. For example, the Scenario Generator module **272** may create a

series of scenarios which will then be sent to the System Analysis and Control module **270** to analyze and validate. Once the scenarios are validated, they may be sent to the Machine Learning module **268** to make predictions on. The predictions made by the Machine Learning module **268** will then be sent back to the Scenario Generator module **272** for analysis. After analyzing the predictions, the Scenario Generator module **272** may decide to send such predictions to the Hot Water System Coordinator **18**, which will then be sent to SMITHGROUP-AI **10**, which in turn may direct the Hot Water System Coordinator **18** to implement one of the scenarios created by Scenario Generator module **246** of the Hot Water System Coordinator **18**.

The Scenario Generator module **268** may create scenarios by varying the heating hot water flow and related temperatures through the boilers or by varying the number of operating pumps. Each such scenario will have an impact on both pump motor energy performance and boiler efficiency.

4. Sample Process

A sample process through which the Hot Water System Coordinator **18** makes predictions related to the overall heating hot water system energy consumption levels or heating hot water system flows and associated temperatures is discussed below.

AHU System Coordinators **20**, **22** and Zone Agents **222**, **224**, **226**, **228**, **230**, **232**, **234** filter the predicted scenarios that are achievable within their own system. Zone Agents **222**, **224**, **226**, **228**, **230**, **232**, **234** may then send heating scenario setpoints (e.g. heating loads, entering water temperatures) to the Hot Water System Coordinator **18**, through the associated AHU System Coordinator **18**. This will be considered "Raw Data" for the Hot Water System Coordinator **18**.

The Hot Water System Coordinator **18** may group all scenarios by the Entering Water Temperature, also known as the temperature the heating plant must provide. During this step, scenarios with temperatures that cannot satisfy all zones will be eliminated.

The Hot Water System Coordinator **18** will create each scenario that could occur at the same time. For instance, Zones **1**, **2**, **3**, **4**, and **5** must have the same Supply Air Temperature (SAT) as it will be served by the same Air Handling Unit. The Hot Water System Coordinator **18** will create these grouped scenarios and assign a Hot Water System ID to each one.

The Hot Water System Coordinator **18** will summarize all grouped scenarios and may predict the overall heating hot water system flow and heating hot water plant return temperature associated with each scenario. These predictions may then be sent to the Heating Plant Agent **220**. The Heating Plant Agent **220** will then make predictions on the heating plant energy consumption for each scenario and will send these predictions back to the Hot Water System Coordinator **18**.

The Hot Water System Coordinator **18** may then predict the overall heating hot water system energy consumption levels for each scenario and may send these predictions to SMITHGROUP-AI **10**. See SMITHGROUP-AI narrative for additional information.

In further detail, each zone agent creates a series of scenarios associated with the zone that it is serving and sends these scenarios to a System Coordinator (e.g. Hot Water System Coordinator **18**). These scenarios are given a unique ID number (Table 6 below) based on a specific airflow supply air temperature (SAT) and a specific entering water temperature (EWT).

41

TABLE 6

Zone Prediction ID	Supply Air Temperature SAT [° F.]	Heating Coil Load Btu/hr	EWT [° F.]	LWT [° F.]	GPM
Agent_1-3_10	52	7500	160	153	2.14
Agent_2-3_10	52	12500	160	153	3.57
Agent_3-3_10	52	6000	160	153	1.71
Agent_4-3_10	52	15000	160	153	4.29
Agent_5-3_10	52	9800	160	153	2.80
Agent_1-4_10	53	5000	160	153	1.43
Agent_2-4_10	53	11000	160	153	3.14
Agent_3-4_10	53	5500	160	153	1.57
Agent_4-4_10	53	13000	160	153	3.71
Agent_5-4_10	53	9200	160	153	2.63

Each system agent that serves a system that uses hot water creates a series of scenarios associated with the system that it is serving and sends these scenarios to a System Coordinator (e.g. Hot Water System Coordinator **18**). These scenarios are given a unique ID number based on a specific airflow supply air temperature (SAT) and a specific entering water temperature (EWT).

The Hot Water System Coordinator then filters the scenarios that it receives (Table 7 below). The filtering process is intended to eliminate scenarios that are not valid for the hot water system at a point in time. For example, an agent may accept a certain cooler hot water temperature (e.g. 155° F. or below), however due to various system conditions, the heating water plant may not be able to achieve such a cooler hot water temperature. This will render the associated scenarios as

TABLE 7

Zone Prediction	Supply Air Temperature SAT [° F.]	Heating Coil Load Btu/hr	EWT [° F.]	LWT [° F.]	GPM
Agent_1-3_10	52	7500	160	153	2.14
Agent_2-3_10	52	12500	160	153	3.57
Agent_3-3_10	52	6000	160	153	1.71
Agent_4-3_6	52	15000	140	132	3.75
Agent_5-3_6	52	9800	140	132	2.45
Agent_1-4_6	53	5000	140	133	1.43

The Hot Water System Coordinator **18** will then start creating combinations of agent scenarios (Table 8 below). Each combination of scenarios is then given a unique ID number (e.g. HWS_160-1). For each combination of agent scenarios there is a corresponding set of hot water plant conditions that need to be achieved (e.g. total heating load, entering water temperature (EWT) leaving water temperature (LWT) and hot water flow (in GPM)).

TABLE 8

Zone Prediction ID	Hot Water System ID	Supply Air Temperature SAT [° F.]	Heating Coil Load Btu/hr	EWT [° F.]	LWT [° F.]	GPM
Agent_1-3_10	HWS_160-1	52	7500	160	153	2.14
Agent_2-3_10		52	12500	160	153	3.57
Agent_3-3_10		52	6000	160	153	1.71
Agent_4-3_10		52	15000	160	153	4.29
Agent_5-3_10		52	9800	160	153	2.80
Zone_6-1_3		80	2100	160	150	0.42
Zone_7-1_1		84	1100	160	155	0.44
Total			54000	160	153.0	15.37

42

The Hot Water System Coordinator **18** then makes hot water system energy consumptions predictions for each combination of agent scenarios (Table 9 below).

TABLE 9

RECEIVED DATA					PREDICTION Hot Water
Hot Water System ID	Heating Coil Load Btu/hr	EWT [° F.]	LWT [° F.]	GPM	Energy Consumption [kWh]
HWS_160-1	54000	160	153.0	15.37	
HWS_160-2	46900	160	153.0	13.35	
HWS_160-3	41900	160	152.8	7.90	
HWS_160-4	36200	160	153.0	7.46	
HWS_160-5	54300	160	153.0	15.45	
HWS_160-6	54400	160	152.8	15.19	
HWS_160-7	54400	160	153.0	15.45	
HWS_160-8	54500	160	153.0	15.49	
HWS_160-9	54600	160	152.8	15.23	
HWS_160-10	36200	180	174.0	12.04	
HWS_160-11	36400	180	174.0	12.12	
HWS_160-12	36600	180	174.0	12.2	

F. Chilled Water System

1. General Description

Referring to FIG. 16, a chilled water system is shown consisting of four chilled water pumps **274**, **276**, **278**, **280**, pumped in parallel, one waterside economizer heat exchanger **282**, and three chillers **284**, **286**, **288**. The distribution piping system consists of two air handling units **290**, **292** and three thermal zones **294**, **296**, **298** with chilled water coils.

The control of the entire chilled water system is performed through a series of independent software agents such as the Chilled Water System Coordinator **16**, Chilled Water Plant Agent **300**, and Zone Agents **302**, **304**, **306**.

2. Chilled Water System Coordinator

a. Purpose

The Chilled Water System Coordinator **16** is an independent software agent that monitors and controls all agents associated with the chilled water system. FIG. 17 shows the communication architecture between the various chilled water system agents.

The Chilled Water System Coordinator **16** is responsible for, but not limited to, the following:

- Satisfy and maintain all building cooling load requirements.
- Optimize chilled water system energy usage.
- Predict energy use of the entire chilled water system.
- Communication with SMITHGROUP-AI **10**. It sends overall chilled water system energy use predictions and receives commands from SMITHGROUP-AI **10**.

Communication with the Chilled Water Plant Agent **300**.

It requests energy consumption predictions and status from the Chilled Water Plant Agent **300** and sends predictions (e.g. total chilled water system water flow, chilled water supply temperature, chilled water return 5 temperature) such that the Chilled Water Plant Agent **300** can make associated predictions related to the energy performance of the Chilled Water Plant.

Further, the Chilled Water System Coordinator **16**, by analyzing the cooling load, water flow and temperature 10 predictions received from the various Zone Agents **304, 306, 308** and AHU System Coordinators **20, 22**, may predict that the chillers are not required to be enabled and that the cooling coils from each AHU **290, 292** may be used to reject the heat absorbed by the chilled water system from the 15 various Zones **294, 296, 298**. The Chilled Water System Coordinator **16** will then send these predictions to SMITHGROUP-AI **10**. For example, by analyzing the predictions from each Zone Agent **302, 304, 306** and AHU System Coordinator **20, 22**, the Chilled Water System Coordinator 20 **16** may determine that a 65° F. temperature will be sufficient to satisfy all cooling loads, without requiring the use of a chiller to cool the water. This can be accomplished by using the chilled water coils from the AHU **290, 292** as heating 25 coils. The energy absorbed by the chilled water coils serving the Zone Agents **302, 304, 306** is transferred to the airstream within each AHU **290, 292** via its associated chilled water coils. Similarly, the Chilled Water System Coordinator **16**, by analyzing the cooling load, water flow and temperature 30 predictions received from the various Zone Agents **302, 304, 306** and AHU System Coordinators **20, 22**, may predict that the chillers are only partially required to cool the chilled water.

b. Internal Structure

Referring to FIG. **18**, the internal structure of the CHWS 35 Coordinator **16** and its related environment is shown. The environment for the Chilled Water System Coordinator **16** consists of all the agents that it monitors and controls. The agents that the Chilled Water System Coordinator **16** controls are all zones/AHUs that contain a chilled water coil and 40 require chilled water from the Chilled Water System **16**. For example, two air handling unit agents **20, 22** and three zone agents **302, 304, 306** are shown. The agent is comprised of five modules, each with dedicated algorithms and control 45 logic.

The Data Filtering module **310** is responsible for separating the data received from the various associated agents **20, 22, 302, 304, 306**. For example, the actual agent energy consumption levels or actual agent chilled water flow may be sent to the System Feedback module **312**, while predictions 50 from the agents will be sent to the System Analysis and Control module **314**.

The System Feedback module **312** is responsible for the following:

Collection of information from the Zone Agents **302, 304, 55 306** and the Chilled Water Plant Agent **300**; the information may represent status (e.g. failed, maintenance), or actual agent energy consumptions levels from the various agents. A failed status may indicate that a Zone Agent **302, 304, 306** may no longer control its environment and should be excluded from the overall 60 condenser water system predictions that the Machine Learning module **316** is making. A maintenance status may indicate that a Zone Agent **302, 304, 306** has entered or may enter into a maintenance mode and that 65 the Machine Learning module **316** needs to update its overall chilled water system predictions accordingly.

The information may also represent predictions related to the energy consumption levels of each agent **300, 302, 304, 306**.

Analysis of predictions related to the total chilled water flow. The actual chilled water flow from the various agents **300, 302, 304, 306** will be compared against their own predictions but also against the predictions made by the Machine Learning module **316**. Any large discrepancies between the predicted and actual chilled water flows could mean that the previous command that a Zone Agent **302, 304, 306** or the Chilled Water Plant Agent **300** received from the Chilled Water System Coordinator **310** has placed an Agent in conflict with its own internal laws (e.g. not able to meet the various zone thermal requirements or expected chilled water system flow). This could indicate that the difference in the error or accuracy of the predictions made by the Machine Learning module **316** and the actual outcome might have exceeded critical limits, which in turn has affected the overall energy and thermal performance of the chilled water system. The System Feedback module **312** will then send the actual chilled water flows to the Machine Learning module **316** such that the Machine Learning module **316** can update its internal learning algorithms.

Collection of information from SMITHGROUP-AI **10**.

The information may represent commands that need to be distributed to the various associated Agents. The information may also represent feedback regarding the predictions that the Chilled Water System Coordinator **16** has made. For example, the predicted energy performance of the Scenario that SMITHGROUP-AI **10** has directed the Chilled Water System Coordinator **310** to implement is significantly different that the real outcome. As such the System Feedback module **312** will pass this feedback to the Machine Learning module **316** to update its machine learning algorithms accordingly such that the accuracy or error of its predictions self-improves.

The Machine Learning module **316** is responsible for the following:

Collection of information from the System Feedback module **312**. The type of information that this module will collect is described under the System Feedback module **312**.

Collection of information from the System Analysis and Control module **314**. This information may represent predictions from Zone Agents **302, 304, 306** and Chilled Water Plant Agent **300** regarding chilled water flows, temperatures, etc.

Making predictions, using machine learning algorithms, based on the data received from the System Analysis and Control module **314**, for the overall energy consumption of the entire chilled water system or for the total chilled water flow that Chilled Water Plant Agent **300** will need to deliver.

Sending the predictions to the System Analysis and Control module **314** and to the Scenario Generator module **318**.

The System Analysis and Control module **314** is responsible for the following:

Collection of information from the Data Filtering module **310**. The type of information that this module will collect is described under the Data Filtering module **310**.

Analyzing the data from each agent, and filtering and compiling the data into valid system scenarios.

Sending the valid system scenarios to the Machine Learning module **316** for predictions.

Receiving the predictions from the Machine Learning module **316** and sending commands to the various agents. The commands that the System Analysis and Control module **314** may send to the agents could be chilled water flows and associated temperatures or requests for predictions.

Analyzing the scenarios proposed by the Scenario Generator module **318**. For each scenario received, the System Analysis and Control module **314** may decide to direct the various agents to make predictions and then compile these predictions into valid system scenarios for the Machine Learning module **316** to make predictions on.

The Scenario Generator module **318** is responsible for continuously looking for ways to improve the overall energy performance of the entire chilled water system. For example, the Scenario Generator module **318** may create a series of scenarios which will then be sent to the System Analysis and Control module **314** to analyze and validate. The System Analysis and Control module **314** may ask the associated agents to make predictions on the scenarios. Once the scenarios are validated, they may be sent to the Machine Learning module **316** to make predictions on. The predictions made by the Machine Learning module **316** will then be sent back to the Scenario Generator **314** module for analysis. After analyzing the predictions, the Scenario Generator module **318** may decide to send such predictions to SMITHGROUP-AI **10**, which in turn may direct the Chilled Water System Coordinator **16** to implement one of the scenarios created by the Scenario Generator module **318**.

The Scenario Generator module **318** may create scenarios by modelling the Chilled Water Plant Agent **300** as delivering various chilled water flows and associated temperatures, by modelling the Zone Agents **302**, **304**, **306** or AHU agents as satisfying their load conditions under various conditions, or by modelling the condenser water plant equipment as being able to support the chillers to generate such chilled water flows and associated temperatures.

3. Chilled Water Plant Agent

a. Purpose

The Chilled Water Plant agent **300** is an independent software agent that monitors and controls the equipment in the chilled water plant equipment (e.g. chillers, water side economizer, chilled water pumps) as energy efficient as possible while satisfying all cooling load requirements. Further, the Chilled Water Plant Agent **300** is responsible for the following:

- a. Prediction of the energy use of the entire chilled water plant.
- b. Prediction of the chillers' energy consumption.
- c. Prediction of the chilled water pumps energy consumption.
- d. Prediction of the water pressure drop through each of the chilled water system piping components (e.g. control valve, heat exchanger, coil).
- e. Communication with the Chilled Water System Coordinator **16**. It receives valid scenario predictions (e.g. total chilled water coil loads, chilled water supply temperature, chilled water return temperature, total chilled water flow) such that the Chilled Water Plant Agent **300** can make associated energy predictions to send back to the Chilled Water System Coordinator **16**.
- f. Communication with the Condenser Water Coordinator **308**. The type of information that the Chilled Water Plant Agent **300** may communicate with the Condenser

Water System Coordinator **308** may represent valid scenarios or conditions (e.g., minimum and maximum condenser water return temperature, minimum and maximum condenser water supply temperature, minimum and maximum condenser water flow) that the Chilled Water Plant Agent **300** needs to account for when making its own energy consumption predictions. Other information that the Condenser Water System Coordinator **308** may communicate with the Chilled Water Plant Agent **300** are predictions related to the condenser water flow, and condenser water return temperature associated with each piece of equipment that is a part of the chilled water plant (e.g. chiller, water side economizer).

b. Internal Structure

Referring to FIG. **19**, the internal structure of the Chilled Water Plant Agent **300** and its related environment is shown. The environment for the Chilled Water System Agent **300** is comprised of all the sensors **320**, **322**, **324**, **326** and actuators **328**, **330**, **332**, **334** of the equipment that it monitors and controls. Sensors **320**, **322**, **324**, **326** and actuators **328**, **330**, **332**, **334** that are part of the Chilled Water System Agent's environment are connected directly to the network, without the use of proprietary controllers that operate with programmed sequences of operation. In some instances, an open source non-proprietary input/output module or a gateway may be required to convert the signal from a sensor or an actuator such that it can be communicated via open source networks such as BACnet, LONworks, Modbus, etc. The agent **300** is comprised of five modules, each with its own dedicated algorithms and controls logic.

The Data Filtering module **336** is responsible for separating the data received from sensors **320**, **322**, **324**, **326** and actuators **328**, **330**, **332**, **334**. For example, the actual energy consumption levels of the chillers and pumps (measured by their related variable frequency drives (VFDs)), actual pump water flows (measured by the associated flow meters) or various temperatures will be sent to the System Feedback module **338**, while data from other various sensors **320**, **322**, **324**, **326** and actuators (e.g. temperatures, status, valve position, differential pressures etc.) **328**, **330**, **332**, **334** will be sent to the System Analysis and Control module **340**.

The System Feedback module **338** is responsible for the following:

- Collection of information from the various sensors **320**, **322**, **324**, **326** and actuators **328**, **330**, **332**, **334**. The type of information that the System Feedback module **338** may collect is described in the Data Filtering module **336**.
- Analysis of predictions related to various water temperatures and flows (e.g. entering and leaving chilled water temperatures, entering and leaving condenser water temperatures, chilled water flow, condenser water flow, etc.). The data received from the various sensors **320**, **322**, **324**, **326** and actuators **328**, **330**, **332**, **334** will be compared against the predictions made by the Machine Learning module **342**. Any large discrepancies between the predicted and measured values could mean that the previous commands could indicate that the difference in the error or accuracy of the predictions made by the Machine Learning module **342** and the actual outcome might have exceeded critical limits, which in turn has affected the overall energy and energy performance of the chilled water system. The System Feedback module **338** will then send the measured values to the Machine Learning module **342** such that the Machine Learning module **342** can update its internal learning algorithms.

Collection of information from the Chilled Water System Coordinator **16**. The information may represent feedback regarding the predictions that the Chilled Water Plant Agent **300** has made. For example, the chilled water plant might deliver a certain chilled water flow to the Zones **294, 296, 298** or to the AHUs **290, 292** in the same time its internal flow meters are confirming that the measured chilled water flow is equal to or close to what was predicted. However, some Zones **294, 296, 298** or AHUs **290, 292**, as measured by their associated flow meters, might not receive sufficient chilled water. This could be indication that the chilled water flow meters within the chilled water plant are defective or that they may need recalibration.

The Machine Learning module **342** is responsible for the following:

Collection of information from the System Feedback module **338**. The type of information that this module will collect is described under the System Feedback module **338**.

Collection of information from the System Analysis and Control module **340**. This information may represent data from the various sensors **320, 322, 324, 326** and actuators **328, 330, 332, 334**, such as water flows and temperatures.

Making predictions, using machine learning algorithms, based on the data received from the System Analysis and Control module **340** or from the System Feedback module **338**.

Sending the predictions to the System Analysis and Control module **340** and to the Scenario Generator module **344**.

Using manufacturers rated chiller performance and chiller curves data as a training set, a machine learning algorithm may be trained to predict the chiller energy consumption at various system conditions (e.g. entering and leaving chilled water temperatures, entering and leaving condenser water temperatures, chiller water flows, condenser water flows etc.). Once released into the real environment, the Machine Learning module **342**, via the feedback received from the System Feedback module **338**, may update its internal machine learning algorithms and related predictions to account for system effects and the measurement errors of the various sensors.

Similarly, using pump laws and manufacturer's rated pump performance data as a training set, a machine learning algorithm may be trained to predict the chilled water pump energy consumption at various system conditions, water flow, and pump head conditions. Once released into the real environment, the Machine Learning module **342**, via the feedback received from the System Feedback module **338**, may update its internal machine learning algorithms and related predictions (e.g. pump motor energy consumption, pump differential sensor pressure setpoints etc.) to account for system effects and the measurement errors of the various sensors.

Using an approach like the above, the Machine Learning module **342** may also use each individual component prediction as a data set and/or training set to make predictions for the energy consumption of the entire chilled water plant. For example, the Machine Learning module **342** may build a training set comprised of the plant chilled water flow, plant entering chilled water temperature, plant leaving chilled water temperature, and pump head and associated pump motor energy consumption. Once the training set is of useful size, the Machine Learning module **342** may use it to predict pump motor energy consumption on new data that is not a part of the training set.

The Machine Learning module **342** will use the training sets described above to operate the chilled water plant as efficiently as possible. The Machine Learning Module **342** may predict the entering water temperatures, leaving water

temperatures, chilled water flow, quantity of chillers, and quantity and speed of chilled water pumps that are required to operate to satisfy building loads based on the predictions received from the Chilled Water System Coordinator **16**.

The System Analysis and Control module **340** is responsible for the following:

Monitoring and control of all sensors and actuators related to the chilled water system.

Collection of information from the Data Filtering module **336**. The type of information that this module will collect is described under the Data Filtering module **336**.

Analyzing the data from each sensor and actuator. For example, the System Analysis and Control module **340** may determine that a pump is no longer capable of running (e.g. the motor has burned out). As such, the System Analysis and Control module **340** may need to update its valid scenario (e.g. how many pumps need to operate and at what speed) to deliver the required amount of water flow to the zones **294, 296, 298**.

Sending the valid system scenarios to the Machine Learning module **342** for predictions.

Receiving the predictions from the Machine Learning module **342** and sending commands to the various actuators **328, 330, 332, 334**. The commands that the System Analysis and Control module **340** may send to the actuators **328, 330, 332, 334** could be valve position or damper position or pump speed.

Analyzing the scenarios proposed by the Scenario Generator module **344**. For each scenario received, the System Analysis and Control module **340** will analyze the status of the current sensors **320, 322, 324, 326** and actuators **328, 330, 332, 334** and will determine which scenario is valid. For example, one of the scenarios that the Scenario Generator module **344** may generate will require the chilled water plant to deliver 1,000 GPM to the chiller. The System Analysis and Control module **340** may determine that, due to a pump failure, such scenario is no longer valid and that the Machine Learning module **342** will not make a prediction on the referenced scenario.

The Scenario Generator module **344** is responsible for continuously looking for ways/scenarios to improve the overall energy performance of the chilled water plant. For example, the Scenario Generator module **344** may create a series of scenarios which will then be sent to the System Analysis and Control module **340** to analyze and validate. Once the scenarios are validated, they may be sent to the Machine Learning module **342** to make predictions on. The predictions made by the Machine Learning module **342** will then be sent back to the Scenario Generator module **344** for analysis. After analyzing the predictions, the Scenario Generator module **344** may decide to send such predictions to the Chilled Water System Coordinator **16**, which will then be sent to SMITHGROUP-AI **10**, which in turn may direct the Chilled Water System Coordinator **16** to implement one of the scenarios created by the Chilled Water System Scenario Generator Module **344**. The Scenario Generator module **344** may create scenarios by varying the chilled water flow and related temperatures to the chillers. Each such scenario will have an impact on both pump motor energy performance and chiller efficiency.

4. Sample Process

Each AHU coordinator **290, 292** and zone agent **294, 296, 298** comprised in the Chilled Water System Coordinator's environment will send a series of predictions and status information. Predictions that the Chilled Water System Coordinator **16** will receive may include the cooling coil load, entering and leaving water temperatures, and various GPMs that the zone agents **302, 304, 306** or AHU Agents could use to satisfy its zone requirements. The System

Analysis and Control module **314** will first compile all predictions received from the zone agents **302, 304, 306** and AHU agents. The system analysis and control module **314** will then eliminate all predictions that will make other agents incapable of meeting their internal laws. For example, all scenarios with EWT greater than 46° F. can be eliminated because AHU-1 **290** and AHU-2 **292** cannot satisfy load requirements with these water temperatures. The system analysis and control module **314** will then compile and sort all remaining predictions based on a common chilled water coil entering water temperature.

The system analysis and control module **314** will then generate all possible combinations of entering water temperatures and total GPMs and summarize scenarios to be sent to the Chilled Water System Agent **300**. The Chilled Water Plant Agent **300** will then determine the most efficient operating scenarios and predict condenser water entering and leaving water temperatures and condenser water flow. The Chilled Water Agent **300** will send these predictions to be validated by the Condenser Water System Coordinator **16**. Once validated, the Chilled Water Plant Agent **300** will then send the final validated scenarios to the Chilled Water System Coordinator **16** which will then send them to SMITHGROUP-AI **10**.

In more detail, each zone agent creates a series of scenarios associated with the zone that it is serving and sends these scenarios to a System Coordinator (e.g. Chilled Water System Coordinator **16**). These scenarios are given a unique ID number (Table 10 below) based on a specific airflow supply air temperature (SAT) and a specific entering water temperature (EWT).

TABLE 10

Zone Agent-9 AGENT PREDICTIONS Data Provided by the Zone Agent						
Zone Prediction ID	Supply Air Temperature SAT [° F.]	Cooling Coil Load Btu/hr	EWT [° F.]	LWT [° F.]	GPM	Energy Predictions KWh
Agent_9-1-1	50	24000	36	44	6.00	0.4
Agent_9-1-2	50	24000	38	49	4.36	0.4
Agent_9-1-3	50	24000	40	47	6.86	0.4
Agent_9-2-1	52	21000	36	48	3.50	0.6
Agent_9-2-2	52	21000	38	53	2.80	0.6
Agent_9-2-3	52	21000	40	51	3.82	0.6

Similarly, each system agent, creates a series of scenarios associated with the system that it is serving and sends these scenarios to a System Coordinator (e.g. Chilled Water System Coordinator **16**). These scenarios are given a unique ID number (Table 11 below) based on a specific airflow supply air temperature (SAT) and a specific entering water temperature (EWT).

TABLE 11

AHU-1 AGENT PREDICTIONS Data Provided by the AHU System Coordinator					
AHU System Prediction ID	Supply Air Temperature SAT [° F.]	Cooling Coil Load Btu/hr	EWT [° F.]	LWT [° F.]	GPM
AHU_1-1-3	52	114480	40	55	15
AHU_1-1-4	52	114480	42	54	19
AHU_1-1-5	52	114480	44	51	33
AHU_1-1-6	52	114480	46	56	23
AHU_1-2-3	54	116964	40	48	29

TABLE 11-continued

AHU-1 AGENT PREDICTIONS Data Provided by the AHU System Coordinator					
AHU System Prediction ID	Supply Air Temperature SAT [° F.]	Cooling Coil Load Btu/hr	EWT [° F.]	LWT [° F.]	GPM
AHU_1-2-4	54	116964	42	53	21
AHU_1-2-5	54	116964	44	55	21

The Chilled Water System Coordinator then filters the scenarios that it receives (Table 12 below). The filtering process is intended to eliminate scenarios that are not valid for the chilled water system at a point in time. For example, an agent may accept a certain low chilled water temperature (e.g. 38° F. or below), however due to outside air temperature conditions, the chilled water plant may not be able to achieve such low chilled water temperature. This will render the associated scenarios as invalid (as indicated in bold).

TABLE 12

Zone Agent-9 AGENT PREDICTIONS Data Provided by the Zone Agent						
Zone Prediction ID	Supply Air Temperature SAT [° F.]	Cooling Coil Load Btu/hr	EWT [° F.]	LWT [° F.]	GPM	Energy Predictions KWh
Agent_9-1-1	50	24000	36	44	6.00	0.4
Agent_9-1-2	50	24000	38	49	4.36	0.4
Agent_9-1-3	50	24000	40	47	6.86	0.4
Agent_9-2-1	52	21000	36	48	3.50	0.6
Agent_9-2-2	52	21000	38	53	2.80	0.6
Agent_9-2-3	52	21000	40	51	3.82	0.6

After the filtering process is complete, the Chilled Water System coordinator **16** compiles all valid scenarios (Table 13 below) that will be used to predict the energy consumption of the chilled water system. It then sorts these scenarios based on a common chilled water temperature (e.g. 40° F.).

TABLE 13

CHILLED WATER SYSTEM AGENT PREDICTIONS					
AHU System Prediction ID	Supply Air Temperature SAT [° F.]	Cooling Coil Load Btu/hr	EWT [° F.]	LWT [° F.]	GPM
AHU_1-1-3	52	114480	40	55	15.26
AHU_1-2-3	54	116964	40	48	29.24
AHU_1-3-3	56	134136	40	46	44.71
AHU_2-1-3	50	240000	40	54	34.29
AHU_2-2-3	52	180000	40	47	51.43
AHU_2-3-3	54	120000	40	51	21.82
Agent_8-1-3	50	15000	40	55	2.00
Agent_8-2-3	52	12000	40	47	3.43
Agent_8-3-3	54	10000	40	51	1.82
Agent_8-4-3	56	8000	40	50	1.60
Agent_9-1-3	50	24000	40	47	6.86
Agent_9-2-3	52	21000	40	51	3.82
Agent_9-3-3	54	18000	40	48	4.50
Agent_9-4-3	56	15000	40	50	3.00

The Chilled Water System Coordinator **16** will then start creating combinations of agent scenarios (Table 14 below). Each combination of scenarios is then given a unique ID number (e.g. CHWS_40-1). For each combination of agent scenarios there is a corresponding set of chilled water plant conditions that need to be achieved (e.g. total cooling load, entering water temperature (EWT), leaving water temperature (LWT) and chilled water flow (in GPM)).

TABLE 14

CHILLED WATER SYSTEM AGENT PREDICTIONS						
System Identification Data		Predictions				
AHU/Zone System Prediction ID	Chilled Water System Prediction ID	Temperature SAT [° F.]	Cooling Coil Load Btu/hr	EWT [° F.]	LWT [° F.]	GPM
AHU_1-1-3	CHWS_40-1	52	114480	40	55	15.26
AHU_2-1-3		50	240000	40	54	34.29
Agent_8-4-3		56	8000	40	50	1.60
Agent_9-3-3		54	18000	40	48	4.50
Total			380480	40	53.7	55.65

The Chilled Water System Coordinator **16** then makes chilled water system energy consumptions predictions for each combination of agent scenarios (Table 15 below) and a unique set of condenser water system operating conditions.

TABLE 15

CHILLED WATER SYSTEM AGENT PREDICTIONS										
System Identification Data		Predictions								
Chilled Water		Condenser Water						Energy Consumption		
Chilled Water System Prediction ID	Load Btu/hr	EWT [° F.]	LWT [° F.]	GPM	EWT [° F.]	LWT [° F.]	GPM	CHWS Pump Energy Consumption KWh	CHWS Energy Consumption KWh	CHWS Total Energy Consumption KWh
CHWS_40-1-1	380480	40	53.7	55.65	85	97	63.4	25	324	249
CHWS_40-1-2	380480	40	53.7	55.65	93	93	58.5	25	302	327
CHWS_40-1-3	380480	40	53.7	55.65	75	88	58.5	25	278	303

The chilled water system energy consumptions predictions are then validated by the Condenser Water System Coordinator **308** (e.g. Table 16 below). This filtering/validation process is required due to the fact that, even though the chilled water plant is able to meet the associated conditions (e.g. chilled water EWT, LWT, GPM, etc.), the

condenser water system may not be able to provide/support the various condenser water system operating conditions (e.g. condenser water EWT, LWT, GPM, etc.). For example, if the outside air temperature is about 95° F., the condenser water system may not be able to achieve a LWT of 80° F. or below.

TABLE 16

CHILLED WATER SYSTEM AGENT PREDICTIONS										
System Identification Data		Predictions								
Chilled Water		Condenser Water						Energy Consumption		
Chilled Water System Prediction ID	Load Btu/hr	EWT [° F.]	LWT [° F.]	GPM	EWT [° F.]	LWT [° F.]	GPM	CHWS Pump Energy Consumption KWh	CHWS Energy Consumption KWh	CHWS Total Energy Consumption KWh
CHWS_40-1-1	380480	40	53.7	55.65	85	97	63.4	75	324	349
CHWS_40-1-2	380480	40	53.7	55.65	80	93	58.5	25	302	327
CHWS_40-1-3	380480	40	53.7	55.65	75	88	58.5	25	278	303
CHWS_40-1-4	380480	40	53.7	55.65	70	80	76.1	25	265	290
CHWS_40-1-5	380480	40	53.7	55.65	65	76	69.2	25	247	272
CHWS_40-1-6	380480	40	53.7	53.65	60	69	84.6	25	224	249
CHWS_40-1-7	380480	40	53.7	55.65	55	65	76.1	25	209	234

After the Chilled Water System Coordinator **16** has received confirmation from the Condenser Water System Coordinator **308**, it then sends the validated scenario combinations to SMITHGROUP-AI **10**.

G. Condenser Water System

1. General Description

Referring to FIG. **20**, a condenser water system is shown as having four condenser water pumps **346, 348, 350, 352**, and three cooling towers, each with two cells **354, 356, 358, 360, 362, 364**. Condenser water is delivered to the chilled water plant equipment (e.g. chillers **368, 370, 372** and the waterside economizer **374**) and to four other zones that require condenser water. The control of the entire condenser water system is performed through the Condenser Water System Coordinator **16**, Chilled Water Plant Agent **300**, Condenser Water Plant Agent **376**, and Zone Agents **378, 380, 384, 386**.

FIG. **21** shows the communication architecture between the various condenser water system Agents **300, 376, 378, 380, 384, 386**. All sensors and actuators are connected directly to the network, without the use of proprietary controllers that operate with programmed sequences of operation. In some instances, an open source non-proprietary input/output module or a gateway may be required to convert the signal from a sensor or an actuator such that it can be communicated via open source networks such as BACnet, LONworks, Modbus, etc.

2. Condenser Water System Coordinator

a. Purpose

The Condenser Water System Coordinator **16** is an independent software agent that monitors and controls all agents associated with its respective condenser water system. Further, the Condenser Water System Coordinator **16** is responsible for the following:

Prediction of the energy use of the entire condenser water system.

Communication with SMITHGROUP-AI **10**. It sends overall condenser water system energy use predictions and receives commands from SMITHGROUP-AI **10**.

Communication with the Condenser Water Plant Agent **376**. It requests energy consumption predictions and status from the Condenser Water Plant Agent **376** and sends predictions (e.g. total condenser water system water flow, condenser water supply temperature, condenser water return temperatures) such that the Condenser Water Plant Agent **376** can make associated predictions related to the energy performance of the Condenser Water Plant.

Communication with the Chilled Water Plant Agent **382**.

The type of information that the Condenser Water System Coordinator **388** communicates to Chilled Water Plant Agent **382** may represent valid scenarios or conditions (e.g., minimum and maximum condenser water return temperature, minimum and maximum condenser water supply temperature, minimum and maximum condenser water flow) that the Chilled Water Plant Agent **382** needs to account for when making its own energy consumption predictions. Other information that the Condenser Water System Coordinator **388** may communicate with the Chilled Water Plant Agent **382** are predictions related to the condenser water flow, and condenser water return temperature associated with each piece of equipment that is a part of the chilled water plant (e.g. chillers **368, 370, 372**, water side economizer **374**).

b. Internal Structure

Referring to FIG. **22**, the internal structure of the Condenser Water System Coordinator **16** and its related environment is shown. The environment for the Condenser Water System Coordinator **16** is comprised of all the agents that it monitors and controls. The agent is comprised of five modules, each with its own dedicated algorithms and controls logic.

The Data Filtering module **388** is responsible for the following:

Separating the data received from the various associated agents. For example, the actual agent energy consumption levels or actual agent condenser water flow will be sent to the System Feedback module **390**, while predictions from the agents will be sent to the System Analysis and Control module **392**.

Collection of information from the Chilled Water Plant Agent **382**. The type of information that the Data Filtering module **388** may collect from the Chilled Water Plant Agent **300** may represent prediction scenarios that the Chilled Water Plant Agent **382** needs to make and for which it needs validation. For example, some of the prediction scenarios that the Chilled Water Plant Agent **382** intends on analyzing may require a condenser water temperature of 85° F. or above. The Data Filtering module **388** will send these prediction scenarios to the System Analysis and Control module **392** for processing and validation.

The System Feedback module **390** is responsible for the following:

Collection of information from the Zone Agents **378, 380, 384, 386**, the Condenser Water Plant Agent **376**, and the Chilled Water Plant Agent **300**. The information may represent status (e.g. failed, maintenance), or actual agent energy consumption levels from the various agents. A failed status may indicate that a Zone Agent **378, 380, 384, 386** no longer controls its environment and should be excluded from the overall condenser water system predictions that the Machine Learning module **394** is making. A maintenance status may indicate that a Zone Agent **378, 380, 384, 386** has entered or may enter into a maintenance mode and that the Machine Learning module **394** needs to update its overall condenser water system predictions accordingly. The information may also represent predictions related to the energy consumption levels of each agent.

Analysis of predictions related to the total condenser water flow. The actual condenser water flow from the various agents will be compared against their own predictions but also against the predictions made by the Machine Learning module **394**. Any large discrepancies between the predicted and actual condenser water flows could mean that the previous command that a Zone Agent **378, 380, 384, 386** or the Condenser Water Plant Agent **376** received from the Condenser Water System Coordinator **16** has placed an Agent in conflict with its own internal laws (e.g. not able to meet the various zone thermal requirements or expected condenser water system flow). This could indicate that the difference in the error or accuracy of the predictions made by the Machine Learning module **394** and the actual outcome might have exceeded critical limits, which in turn has affected the overall energy and thermal performance of the condenser water system. The System Feedback module **390** will then send the actual condenser water flows to the Machine Learning module **394** such that the Machine Learning module **394** can update its internal learning algorithms.

Collection of information from SMITHGROUP-AI **10**.

The information may represent commands that need to be distributed to the various associated Agents. The information may also represent feedback regarding the predictions that the Condenser Water System Coordinator **16** has made. For example, the predicted energy performance of the Scenario that SMITHGROUP-AI **10** has directed the Condenser Water System Coordinator **16** to implement is significantly different that the real outcome. As such the System Feedback module **390** will pass this feedback to the Machine Learning module **394** to update its machine learning algorithms accordingly such that the accuracy or error of its predictions self-improves.

The Machine Learning module **394** is responsible for the following:

Collection of information from the System Feedback module **390**. The type of information that this module will collect is described under the System Feedback module **390**.

Collection of information from the System Analysis and Control module **392**. This information may represent predictions from Zone Agents **378, 380, 384, 386** and Condenser Water Plant Agent **376** regarding condenser water flows, temperatures, etc.

Making predictions, using machine learning algorithms, based on the data received from the System Analysis and Control module **392**, for the overall energy consumption of the entire condenser water system or for the total condenser water flow that the Condenser Water Plant Agent **376** will need to deliver.

Sending the predictions to the System Analysis and Control module **392** and to the Scenario Generator module **396**.

The System Analysis and Control module **392** is responsible for the following:

Collection of information from the Data Filtering module **388**. The type of information that this module will collect is described under the Data Filtering module **388**.

Analyzing the data from each agent, and filtering and compiling the data into valid system scenarios.

Sending the valid system scenarios to the Machine Learning module **394** for predictions.

Receiving the predictions from the Machine Learning module **394** and sending commands to the various agents. The commands that the System Analysis and Control module **392** may send to the agents could be condenser water flows and associated temperatures, or requests for predictions.

Analyzing the scenarios proposed by the Scenario Generator module **396**. For each scenario received, the System Analysis and Control module **392** may decide to direct the various agents to make predictions and then compile these predictions into valid system scenarios for the Machine Learning module **394** to make predictions on.

Analyzing the scenarios proposed by the Scenario Generator module **396** that require input from the Chilled Water Plant Agent **382**. For each scenario received, the System Analysis and Control module **392** may decide to ask the Chilled Water Plant Agent **382** to make predictions and then send the predictions back to the Data Filtering module **388**.

The Scenario Generator module **396** is responsible for continuously looking for ways to improve the overall energy performance of the entire condenser water system. For

example, the Scenario Generator module **396** may create a series of scenarios that will then be sent to the System Analysis and Control module **392** to analyze and validate. The System Analysis and Control module **392** may ask the agents to make predictions on the scenarios. Once the scenarios are validated, they may be sent to the Machine Learning module **394** to make predictions on. The predictions made by the Machine Learning module **394** will then be sent back to the Scenario Generator module **396** for analysis. After analyzing the predictions, the Scenario Generator module **396** may decide to send such predictions to SMITHGROUP-AI **10**, which in turn may direct the Condenser Water System Coordinator **16** to implement one of the scenarios created by the Scenario Generator module **396**.

The Scenario Generator module **396** may create scenarios by modelling the Condenser Water Plant Agent **376** as delivering various condenser water flows and associated temperatures and by modelling the Zone Agents **378, 380, 384, 386** as satisfying their zone thermal load conditions under various conditions or by modelling the chilled water plant equipment as being able to support such condenser water flows and associated temperatures.

c. Sample Process

The process through which the Condenser Water System Coordinator **16** makes predictions related to the overall condenser water system energy consumption levels or condenser water system flows and associated temperatures is similar to the process that the Chilled Water System Coordinator **16** is implementing when making predictions related to the overall chilled water system energy consumption levels or chilled water system flows and associated temperatures.

3. Condenser Water Plant Agent

a. Purpose

The Condenser Water Plant Agent **376** is an independent software agent that monitors and controls all sensors **398, 400, 402, 404** and actuators **406, 408, 410, 412** associated with the condenser water plant. The condenser water plant is comprised of cooling towers and condenser water pumps. Further, the Condenser Water Plant Agent **376** is responsible for the following:

Prediction of the energy use of the entire condenser water plant.

Communication with the Condenser Water System Coordinator **16**. It sends overall condenser water plant energy use predictions and receives commands from the Condenser Water System Coordinator **16**.

b. Internal Structure

Referring to FIG. **23**, the internal structure of the Condenser Water Plant Agent **376** and its related environment is shown. The environment for the Condenser Water Plant Agent **376** is comprised of the sensors and actuators that are used to monitor and control the condenser water plant. The agent is comprised of five modules, each with its own dedicated algorithms and controls logic.

The Data Filtering module **414** is responsible for separating the data received from sensors **398, 400, 402, 404** and actuators **406, 408, 410, 412**. For example, the energy consumption levels of cooling tower fans or condenser water pumps (measured by their related Variable Frequency Drives (VFD)), actual condenser water flow (measured by the associated flow meter), or various temperatures (e.g. condenser water leaving temperature, condenser water return temperature, etc.) will be sent to the System Feedback module **416**, while data from other various sensors (e.g. alarms, temperatures etc.) will be sent to the System Analysis and Control module **418**. The Data Filtering module **414**

may also send to the System Analysis and Control module **418** the same data that was sent to the System Feedback module **416**.

The System Feedback module **416** is responsible for the following:

Collection of information from the various sensors **398**, **400**, **402**, **404** and actuators **406**, **408**, **410**, **412**. The type of information that the System Feedback module **416** may collect is described in the Data Filtering module **414**.

Analysis of predictions related to various temperatures (e.g. condenser water leaving temperature, condenser water return temperature, etc.). The data received from the various sensors and actuators will be compared against the predictions made by the Machine Learning module **420**. Any large discrepancies between the predicted and measured values could mean that the previous commands could indicate that the difference in the error or accuracy of the predictions made by the Machine Learning module **420** and the actual outcome might have exceeded critical limits, which in turn has affected the overall energy and energy performance of the condenser water plant. The System Feedback module **416** will then send the measured values to the Machine Learning module **420** such that the Machine Learning module **420** can update its internal learning algorithms.

Collection of information from the Condenser Water System Coordinator **16**. The information may represent feedback regarding the predictions that the Condenser Water Plant Agent **376** has made. For example, the condenser water plant might deliver a certain flow of condenser water to the Zones or to the chilled water plant in the same time its internal flow meters are confirming that the measured condenser water flow is equal to or close to what was predicted. However, some Zones or the chilled water plant, as measured by their associated flow meters, might not receive sufficient condenser water. This could be indication that the water flow meters are defective or that they may need recalibration.

The Machine Learning module **420** is responsible for the following:

Collection of information from the System Feedback module **416**. The type of information that this module will collect is described under the System Feedback module **416**.

Collection of information from the System Analysis and Control module **418**. This information may represent data from the various sensors and actuators, such as condenser water flows and associated temperatures.

Making predictions, using machine learning algorithms, based on the data received from the System Analysis and Control module **418** or from the System Feedback module **416**.

Sending the predictions to the System Analysis and Control module **418** and to the Scenario Generator module **422**.

For each component (e.g. cooling tower, condenser water pump etc.) of the condenser water plant, the Machine Learning module **420** will use various machine learning algorithms to predict its performance (e.g. Btu/hr, leaving water temperature etc.), water flow, water pressure drops, and energy consumption (e.g. kWh).

For example, a cooling tower has fixed properties (e.g. width, height, fan horsepower etc.). As such, a machine learning algorithm may be trained, via the use of manufac-

turer's rated cooling tower performance data at various conditions (e.g. various entering wet bulb air temperatures, entering condenser water temperatures and flow), to predict what the leaving condenser water temperature, or associated condenser water pressure drop may be at other conditions not included in the training data set.

Similarly, using pump laws and manufacturer's rated pump performance data as a training set, a machine learning algorithm may be trained to predict what the condenser water pump energy consumption may be at various system conditions (e.g. various water flows and various associated pump head). Once released into the real environment, the Machine Learning module **420**, via the feedback received from the System Feedback module **416**, may update its internal machine learning algorithms and related predictions (e.g. pump motor energy consumption, pump head setpoints etc.) to account for system effects and for the measurement errors of the various sensors.

Using an approach similar to the above, the Machine Learning module **420** may also use each individual component prediction as a data set and/or training set to make predictions for the energy consumption of the entire condenser water plant. For example, the Machine Learning module **420** may build a training set comprised of the plant condenser water flow, plant entering condenser water temperature, plant leaving condenser water temperature, pump head and associated pump motor energy consumption. Once the training set is of useful size, the Machine Learning module **420** may use it to predict pump motor energy consumption on new data that is not a part of the training set.

The Machine Learning module **420** will use the training sets described above to operate the condenser water plant as efficiently as possible. The Machine Learning module **420** may predict the entering water temperatures, leaving water temperatures, condenser water flow, quantity of towers, and quantity and speed of condenser water pumps that are required to operate to satisfy condenser water load requirements based on the predictions received from the Condenser Water System Coordinator **16**.

The System Analysis and Control module **418** is responsible for the following:

Monitoring and control of all sensors and actuators related to the condenser water plant.

Collection of information from the Data Filtering module **414**. The type of information that this module will collect is described under the Data Filtering module **414**.

Analyzing the data from each sensor and actuator. For example, the System Analysis and Control module **418** may determine that a cooling tower fan is no longer capable of running (e.g. the motor has burned out). As such, the System Analysis and Control module **418** may need to update its valid scenarios (e.g. how many cooling tower fans need to operate and at what speed) to deliver the required condenser water plant temperature and flow to the Zones and to the chilled water plant.

Sending the valid system scenarios to the Machine Learning module **420** for predictions.

Receiving the predictions from the Machine Learning module **420** and sending commands to the various actuators. The commands that the System Analysis and Control module **418** may send to the actuators could be valve position, cooling tower fan speed, or condenser water pump speed.

Analyzing the scenarios proposed by the Scenario Generator module **422**. For each scenario received, the

System Analysis and Control module **418** will analyze the status of the current sensors and actuators and will determine which scenario is valid. For example, one of the scenarios that the Scenario Generator module **422** may generate will require the condenser water plant to deliver 2,000 GPM of condenser water at 65° F. to the Zones and to the chilled water plant. The System Analysis and Control module **418** may determine that, due to a cooling tower fan failure or condenser water pump failure, such scenario is no longer valid (due to limited condenser water plant capacity) and that the Machine Learning module **420** will not make a prediction on the referenced scenario.

The Scenario Generator module **422** is responsible for continuously looking for ways/scenarios to improve the overall energy performance of the condenser water plant. For example, the Scenario Generator module **422** may create a series of scenarios that will then be sent to the System Analysis and Control module **418** to analyze and validate. Once the scenarios are validated, they may be sent to the Machine Learning module **420** to make predictions on. The predictions made by the Machine Learning module **420** will then be sent back to the Scenario Generator module **422** for analysis. After analyzing the predictions, the Scenario Generator module **422** may decide to send such predictions to the Condenser Water System Coordinator **16**, which may send them to SMITHGROUP-AI **10**, which in turn may direct the Condenser Water System Coordinator **16** to implement one of the scenarios created by the Scenario Generator module **16**.

The Scenario Generator module **422** may create scenarios by varying the cooling tower air flows, water flows and related temperatures. Each such scenario will have an impact on the energy performance of the motors serving the tower fans or the condenser water pumps.

The algorithms, processes, methods, logic, or strategies disclosed may be deliverable to and/or implemented by a processing device, controller, or computer, which may include any existing programmable electronic control unit or dedicated electronic control unit. The supervisors, coordinators, and agents contemplated herein may be implemented across several processors as shown in FIG. **1** or a single processor, etc. Similarly, the algorithms, processes, methods, logic, or strategies may be stored as data and instructions executable by a controller or computer in many forms including, but not limited to, information permanently stored on various types of articles of manufacture that may include persistent non-writable storage media such as ROM devices, as well as information alterably stored on writable storage media such as floppy disks, magnetic tapes, CDs, RAM devices, and other magnetic and optical media. The algorithms, processes, methods, logic, or strategies may also be implemented in a software executable object. Alternatively, they may be embodied in whole or in part using suitable hardware components, such as Application Specific Integrated Circuits (ASICs), Field-Programmable Gate Arrays (FPGAs), state machines, controllers or other hardware components or devices, or a combination of hardware, software and firmware components.

The words used in the specification are words of description rather than limitation, and it is understood that various changes may be made without departing from the spirit and scope of the disclosure and claims. As previously described, the features of various embodiments may be combined to form further embodiments that may not be explicitly described or illustrated. While various embodiments may have been described as providing advantages or being

preferred over other embodiments or prior art implementations with respect to one or more desired characteristics, those of ordinary skill in the art recognize that one or more features or characteristics may be compromised to achieve desired overall system attributes, which depend on the specific application and implementation. These attributes include, but are not limited to cost, strength, durability, life cycle cost, marketability, appearance, packaging, size, serviceability, weight, manufacturability, ease of assembly, etc. As such, embodiments described as less desirable than other embodiments or prior art implementations with respect to one or more characteristics are not outside the scope of the disclosure and may be desirable for particular applications.

What is claimed:

1. A hierarchical resource management system for a building that has a plurality of zones each with a corresponding resource arranged to alter an environment of the zone, the system comprising:

- one or more processors programmed to implement
 - a coordinator configured to, responsive to receipt of operating scenarios from each of a plurality of agents, filter the operating scenarios to remove the operating scenarios that violate internal laws of the agents to form an aggregate validated set of operating scenarios, and
 - a supervisor configured to, responsive to receipt of target conditions for the zones and the aggregate validated set of operating scenarios from the coordinator,
 - select a combination of the operating scenarios from the aggregate validated set of operating scenarios that achieves the target conditions and minimizes overall energy consumption by the resources such that some of the operating scenarios of the combination do not minimize energy consumption of the resources corresponding to the some of the operating scenarios, and
 - direct the coordinator to command operation of the resources according to the combination of the operating scenarios.

2. The system of claim **1**, wherein the one or more processor are further programmed to implement the plurality of agents, each of the agents being configured to monitor sensed values describing conditions of one of the zones,

- generate the operating scenarios based on the sensed values for the resource corresponding to the one of the zones, each of the operating scenarios describing an array of set point values for the resource and corresponding to an energy consumption of the resource, and operate the resource according to a commanded one of the operating scenarios.

3. The system of claim **2**, wherein the agents are further configured to execute machine learning algorithms to generate the operating scenarios.

4. The system of claim **1**, wherein the supervisor is further configured to execute machine learning algorithms to select the combination of the operating scenarios from the aggregate validated set of operating conditions.

5. The system of claim **1**, wherein the agents are further configured to report the internal laws to the coordinator.

6. The system of claim **1**, wherein one of the zones is a thermal zone and the resource corresponding to the thermal zone is a heating ventilating and air conditioning unit.

61

7. The system of claim 1, wherein one of the zones is a lighting zone.

8. The system of claim 1, wherein one of the zones is an electrical switched receptacle zone.

* * * * *

62