

US011544937B2

(12) **United States Patent**
Minami et al.

(10) **Patent No.:** **US 11,544,937 B2**
(45) **Date of Patent:** **Jan. 3, 2023**

(54) **CONTROL DEVICE, CONTROL METHOD,
AND COMPUTER READABLE MEDIUM**

(56)

References Cited

U.S. PATENT DOCUMENTS

(71) Applicant: **Mitsubishi Logisnext Co., Ltd.**, Kyoto (JP)

10,882,538 B1 * 1/2021 Witt G01S 15/931

10,902,263 B1 * 1/2021 Angel A61H 3/061

(72) Inventors: **Shogo Minami**, Kyoto (JP); **Koji Shiizaki**, Kyoto (JP); **Akira Ando**, Kyoto (JP); **Hajime Kodaira**, Kyoto (JP); **Kiichi Sugimoto**, Tokyo (JP); **Kenta Nakao**, Tokyo (JP); **Satoshi Iio**, Tokyo (JP)

2006/0274147 A1 12/2006 Chinomi et al.

2013/0147958 A1 * 6/2013 Mitsuta B60K 35/00

2015/0183370 A1 * 7/2015 Nakanishi E02F 9/261

2018/0027179 A1 1/2018 Matsuzaki et al.

(Continued)

(73) Assignee: **Mitsubishi Logisnext Co., Ltd.**, Kyoto (JP)

FOREIGN PATENT DOCUMENTS

(*) Notice: Subject to any disclaimer, the term of this patent is extended or adjusted under 35 U.S.C. 154(b) by 177 days.

JP H-7-206396 A 8/1995

JP A-2005-134971 5/2005

(Continued)

(21) Appl. No.: **16/843,935**

OTHER PUBLICATIONS

(22) Filed: **Apr. 9, 2020**

Extended European Search Report for European Application No. 20168787.8, dated Jun. 16, 2020.

(65) **Prior Publication Data**

(Continued)

US 2020/0327341 A1 Oct. 15, 2020

(30) **Foreign Application Priority Data**

Primary Examiner — Md K Talukder

Apr. 11, 2019 (JP) JP2019-075677

Mar. 4, 2020 (JP) JP2020-037260

(74) *Attorney, Agent, or Firm* — Blank Rome LLP

(51) **Int. Cl.**

G06V 20/58 (2022.01)

B62D 15/02 (2006.01)

(57)

ABSTRACT

(52) **U.S. Cl.**

CPC **G06V 20/58** (2022.01); **B62D 15/021** (2013.01)

A control device includes a specifying unit that specifies one of a plurality of detection objects on the basis of a state of an industrial vehicle when the plurality of detection objects are detected around the industrial vehicle, and a control unit that causes a notification to be performed for the one detection object specified by the specifying unit in an aspect different from those of other detected detection objects.

(58) **Field of Classification Search**

CPC G06K 9/00805; B62D 15/021; G06V 20/58; B66F 17/003; E02F 9/24; E02F 9/261; H04N 7/181; G08G 1/166

8 Claims, 10 Drawing Sheets

See application file for complete search history.

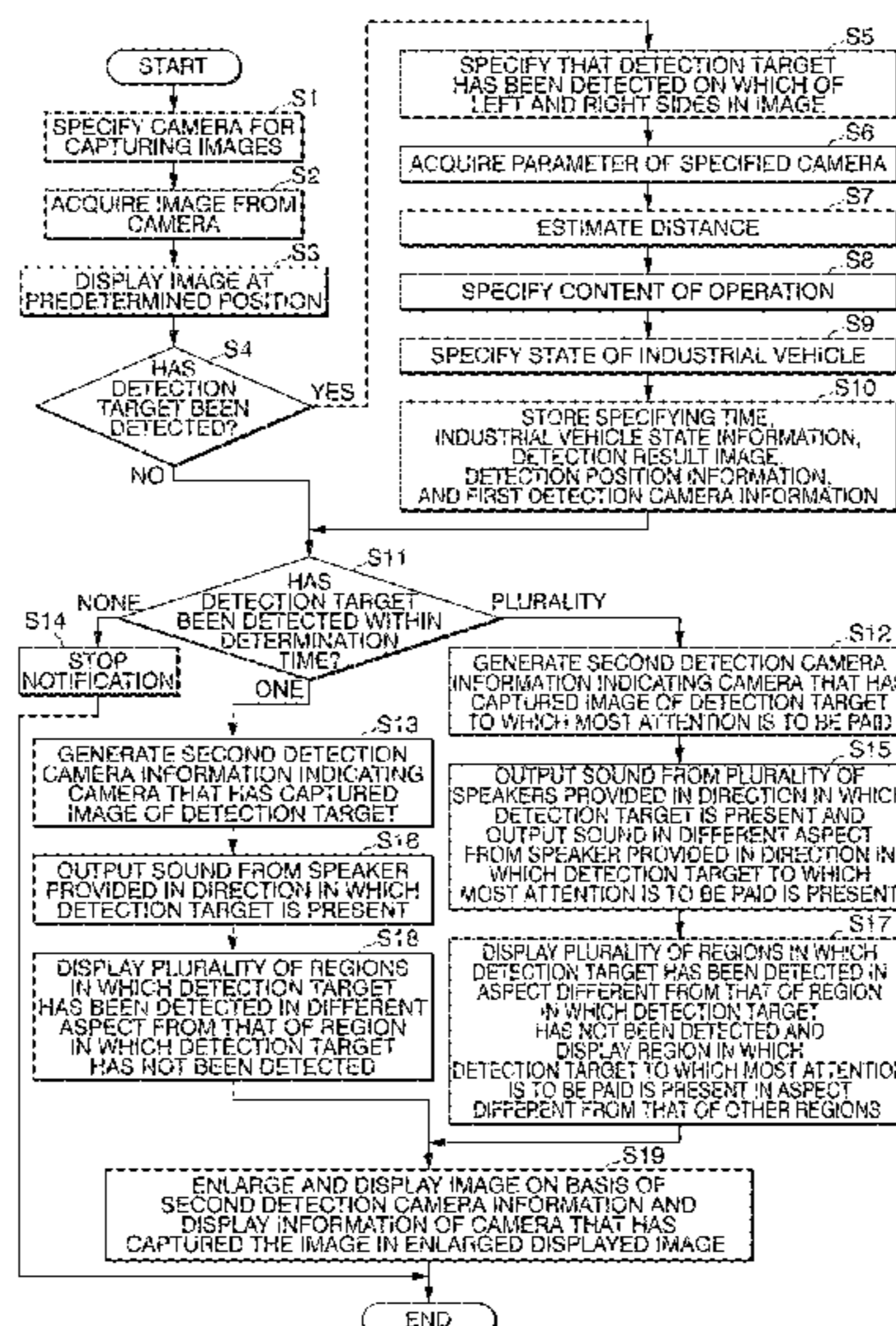

(56)

References Cited

U.S. PATENT DOCUMENTS

2018/0057049 A1 3/2018 Stewart et al.
 2018/0301029 A1* 10/2018 Nilsson G06V 20/58
 2019/0111843 A1* 4/2019 Yamada B60K 35/00
 2019/0266859 A1* 8/2019 Song G05D 1/0248
 2019/0273977 A1* 9/2019 Miyasaka H04S 1/00
 2020/0082185 A1* 3/2020 Yamamoto G06V 20/58
 2020/0189614 A1* 6/2020 Ito G06V 20/597
 2020/0277757 A1* 9/2020 Kurokami E02F 9/24
 2020/0327341 A1* 10/2020 Minami E02F 9/261

FOREIGN PATENT DOCUMENTS

JP A-2006-011516 1/2006
 JP 2010-198519 A 9/2010
 JP 2010198519 A * 9/2010 E02F 9/24
 JP A-2015-009646 1/2015
 JP 2016-222428 A 12/2016

JP 2017-101420 A 6/2017
 JP A-2018-014554 1/2018
 JP A-2018-157449 10/2018

OTHER PUBLICATIONS

Chinese Office Action for Chinese Application No. 202010251651.3, dated Apr. 27, 2021.
 EP20168787.8, Jun. 16, 2020, Extended European Search Report. Office Action dated Feb. 16, 2021, Japanese Application No. 2020-037260, with English translation.
 JP2019-075677, Feb. 25, 2020, Office Action.
 Office Action for Japanese Application No. 2019-075677, dated Feb. 25, 2020.
 [No Author Listed] Vision Plus Brochure: Sensor-less, Tag-less Technology. Vision Plus. https://taylorforklifts.com/brochures/interactive/visionplus-brochure_ver2108/, dated Sep. 24, 2018, 4 pages.
 Japanese Office Action for Japanese Application No. 2020-037260, dated Oct. 19, 2021.

* cited by examiner

FIG. 1

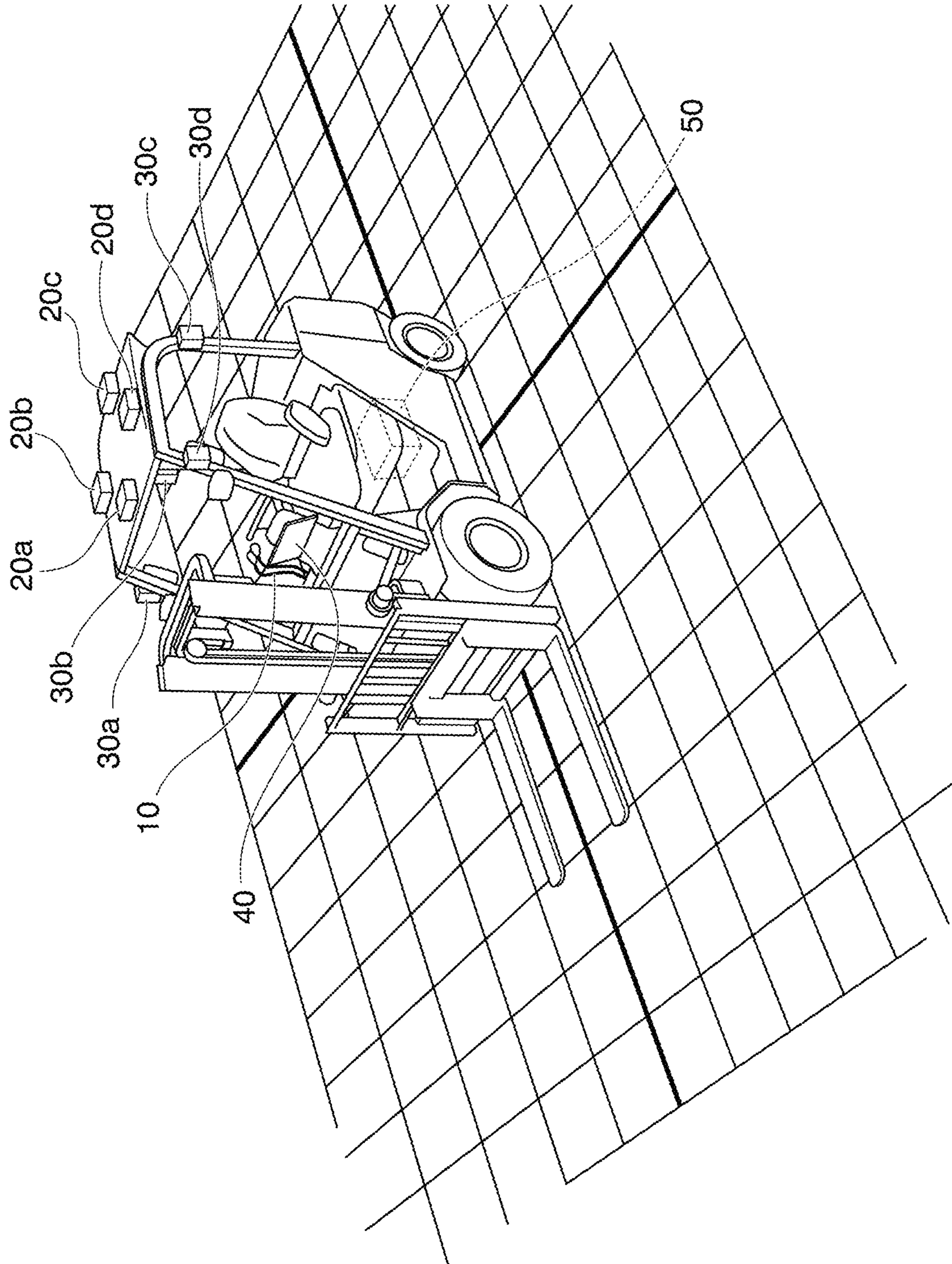

FIG. 2

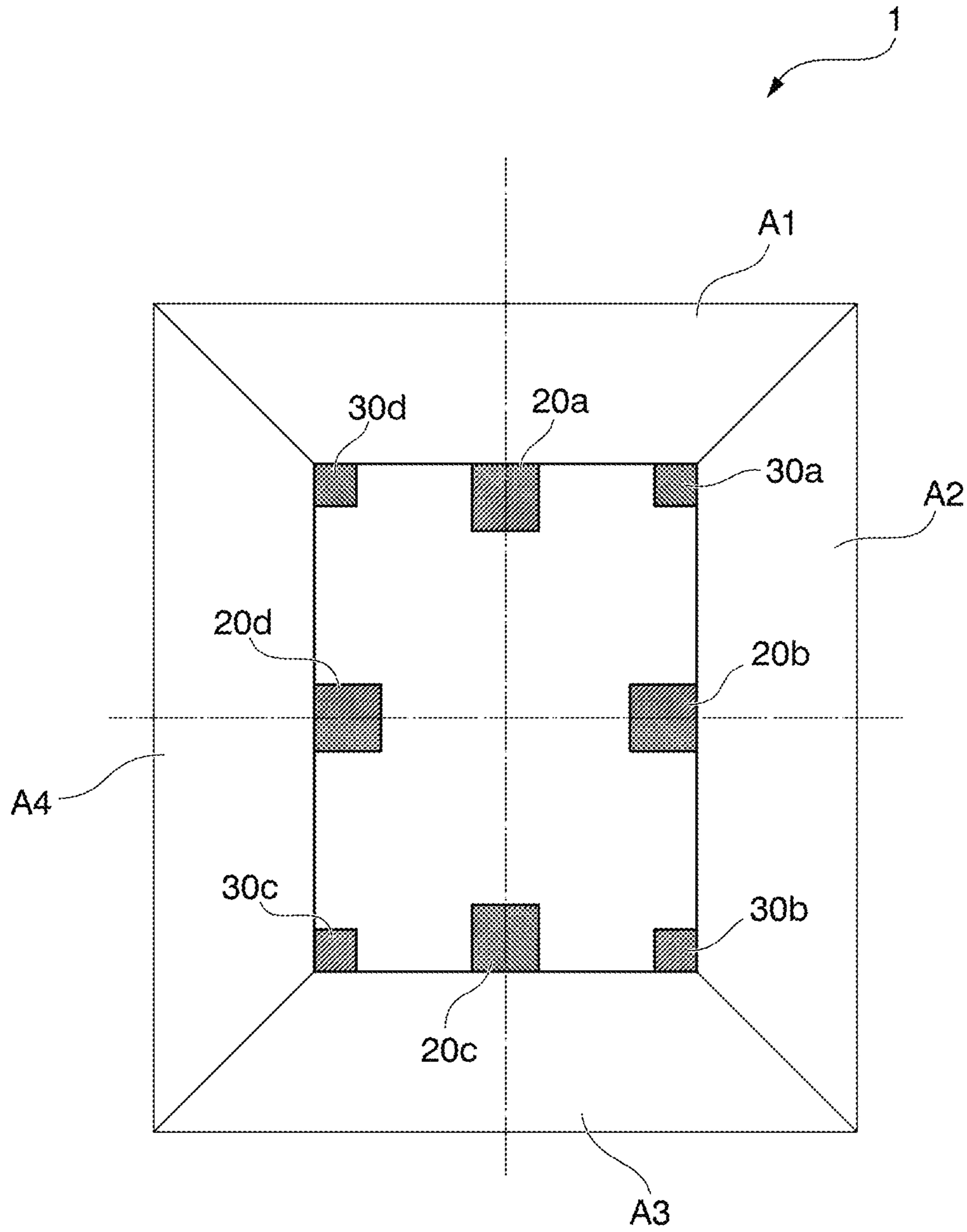

FIG. 3

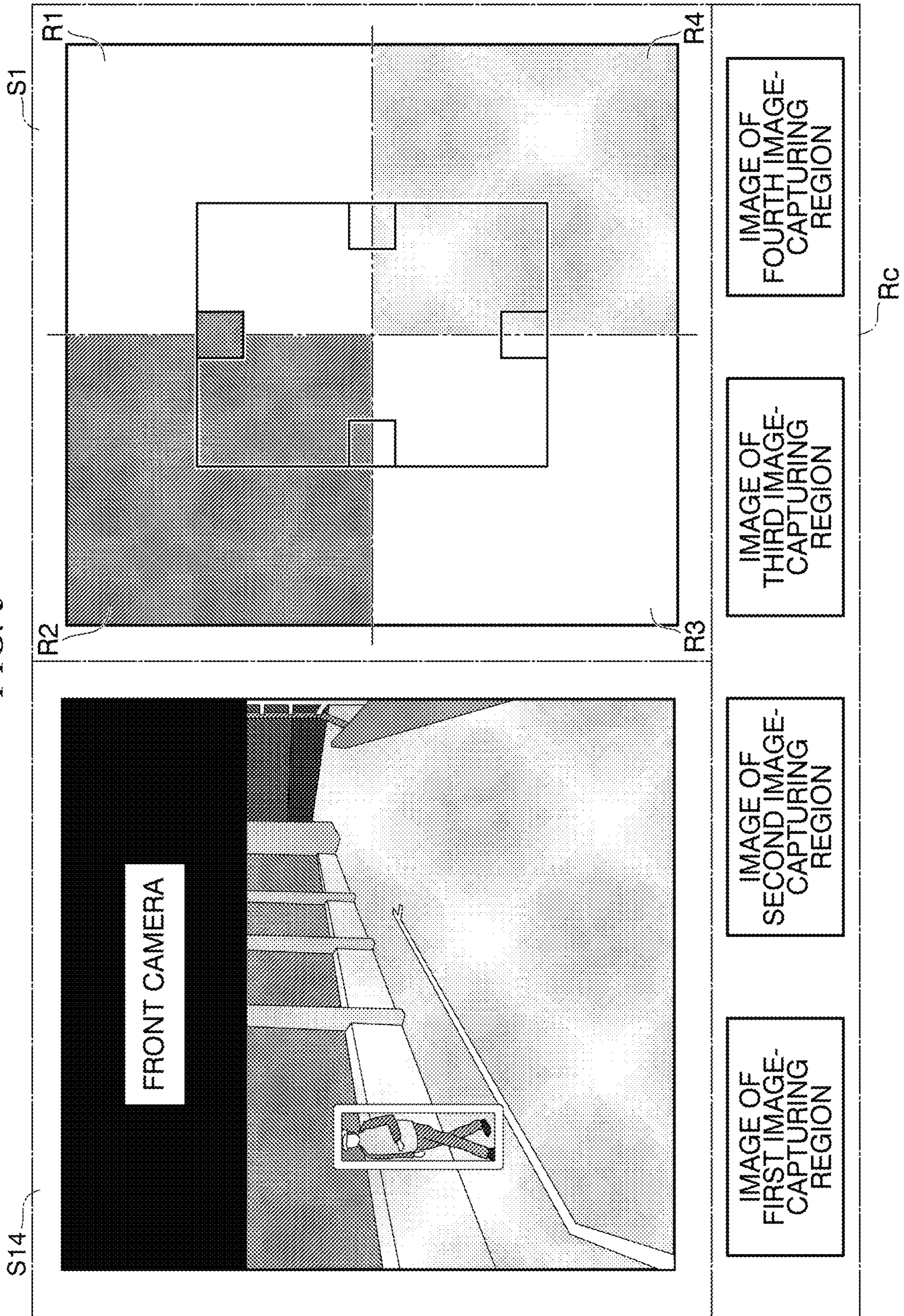

FIG. 4

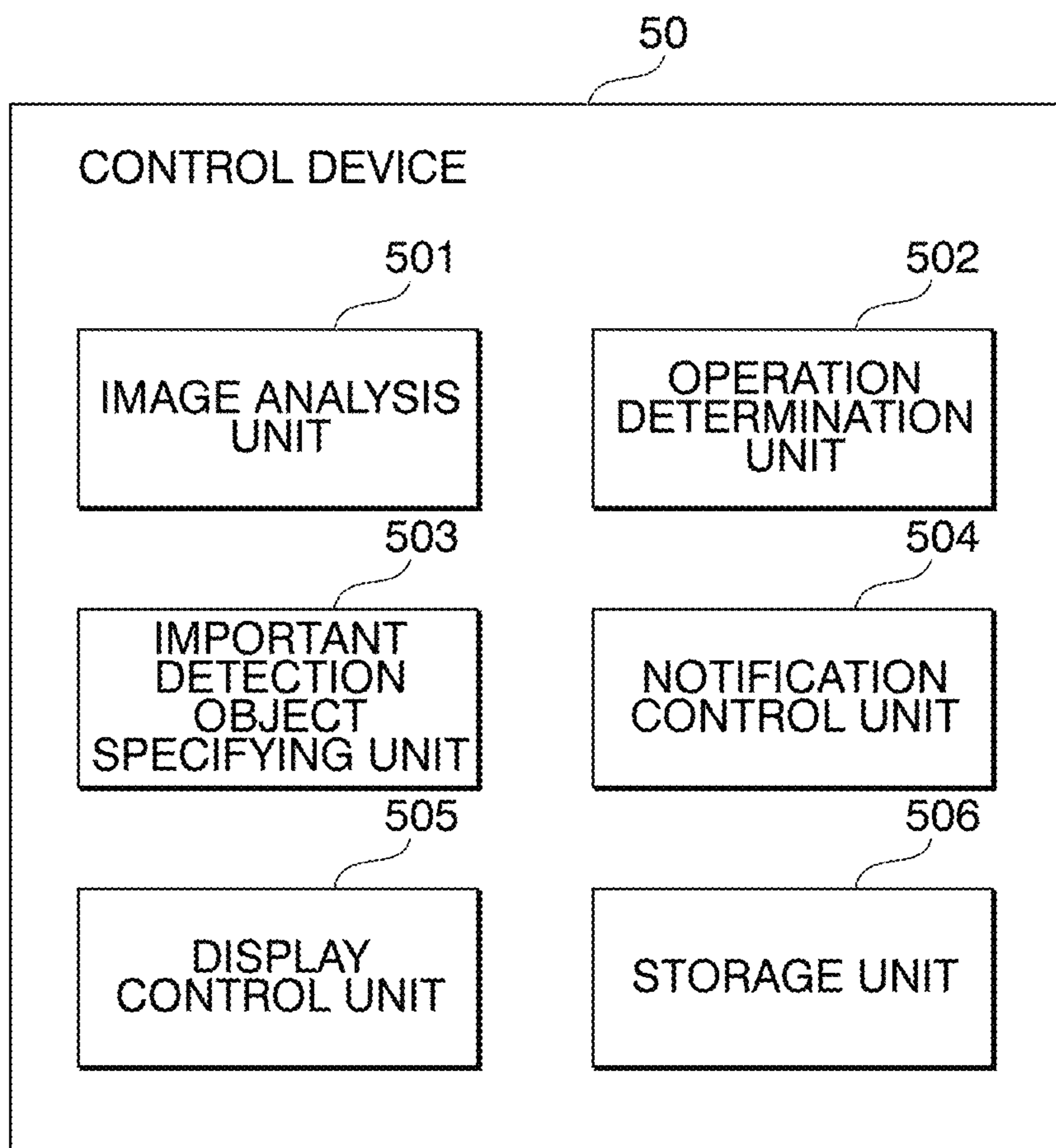

FIG. 5

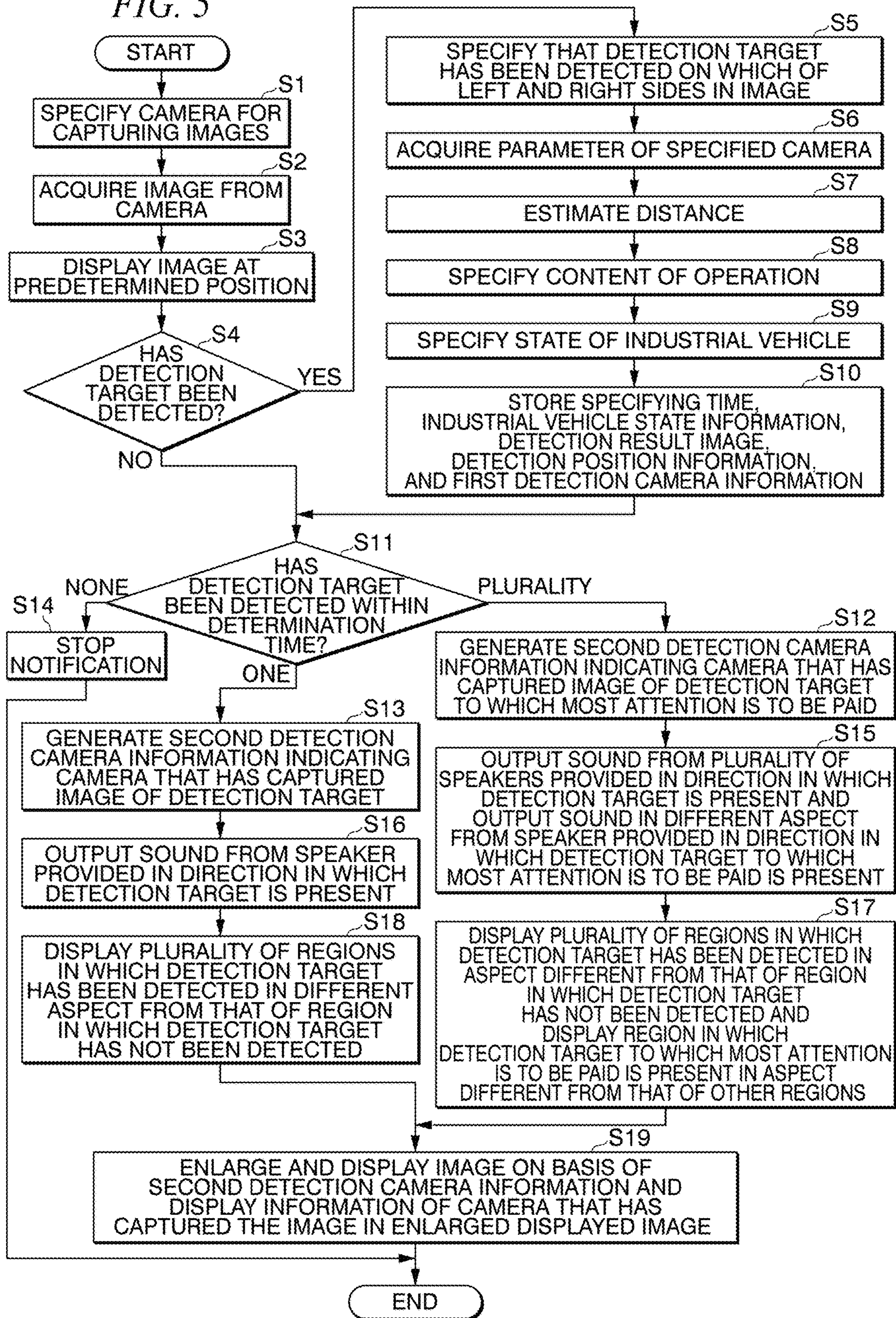

FIG. 6

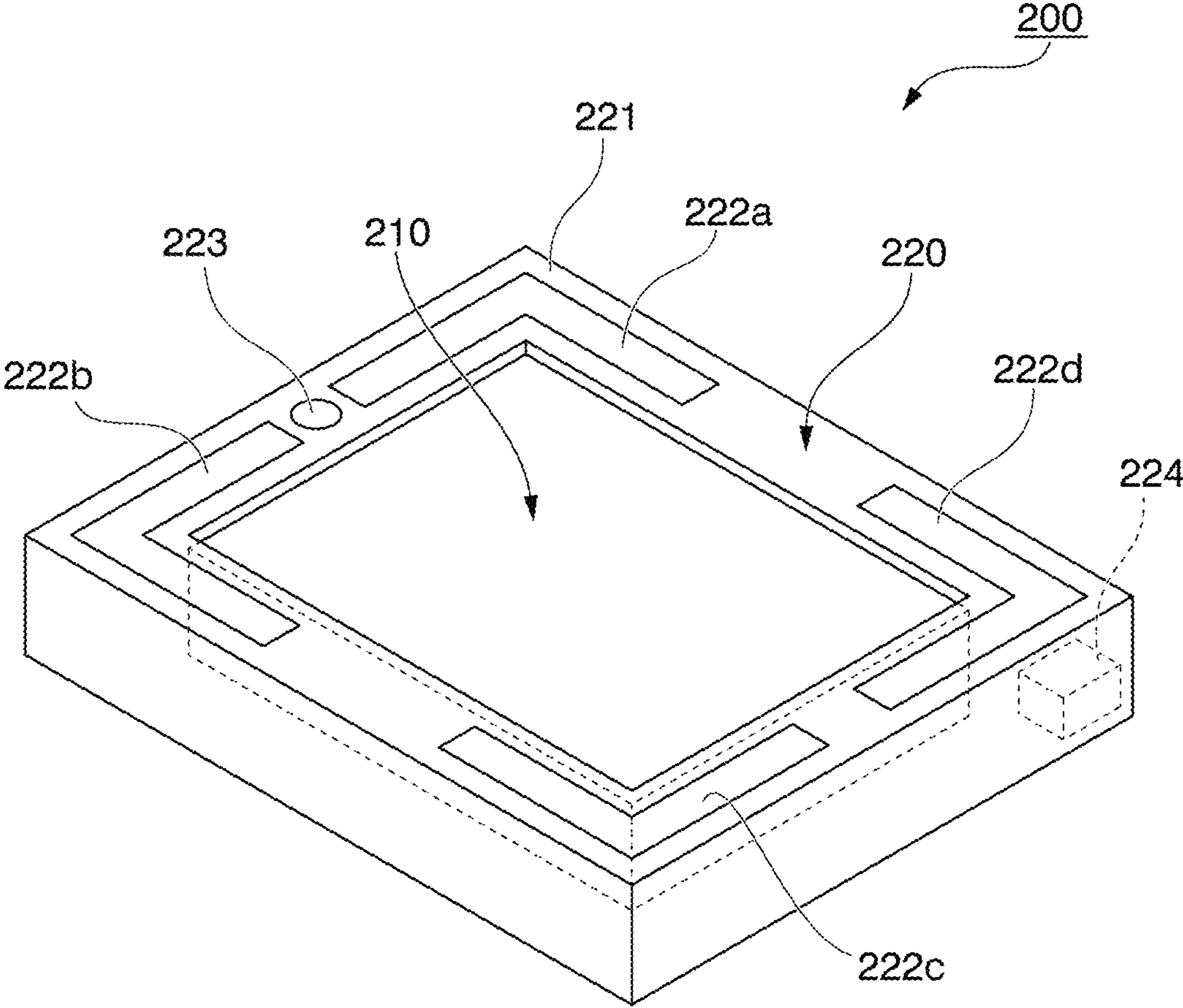

FIG. 7

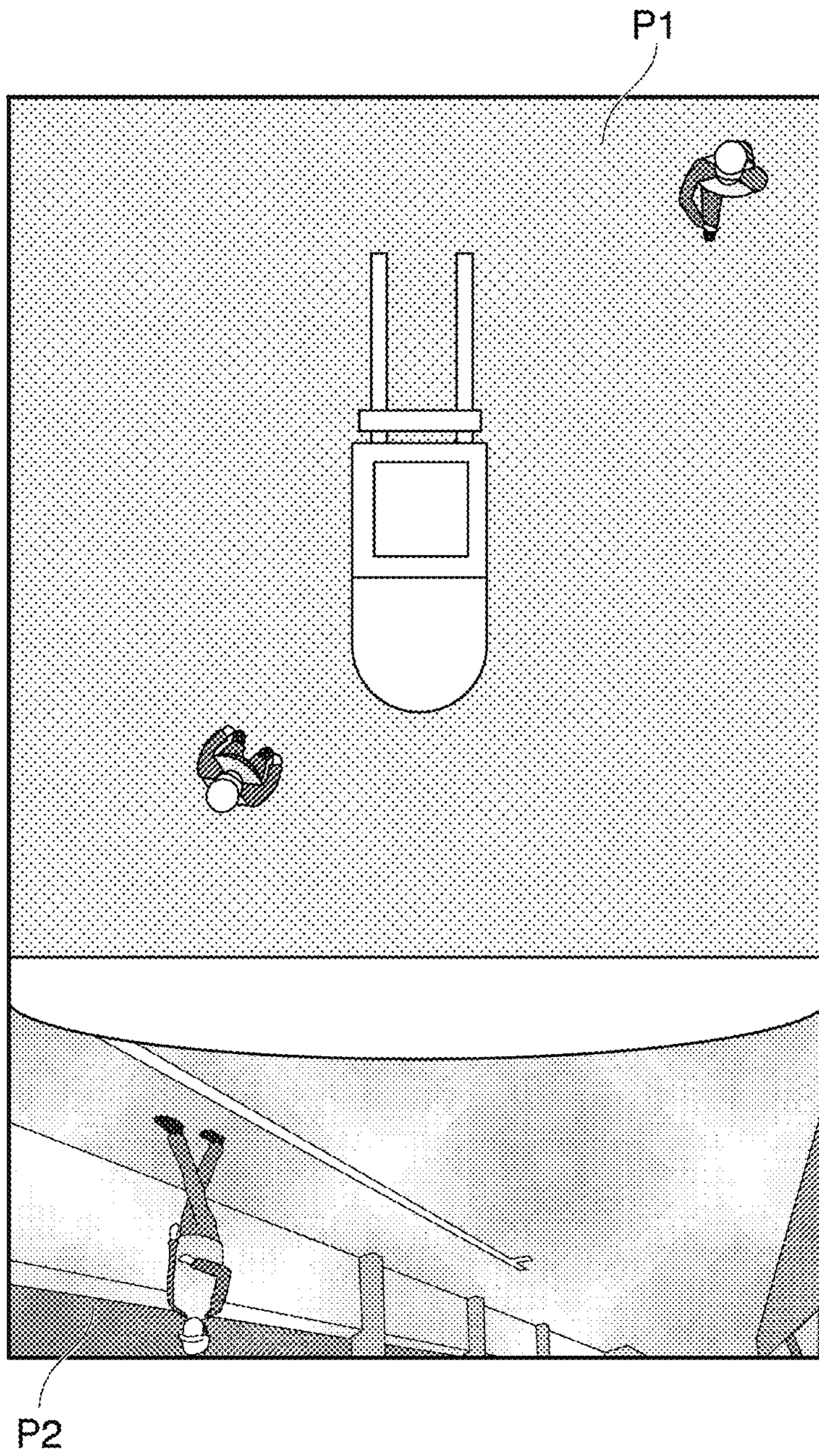

FIG. 8

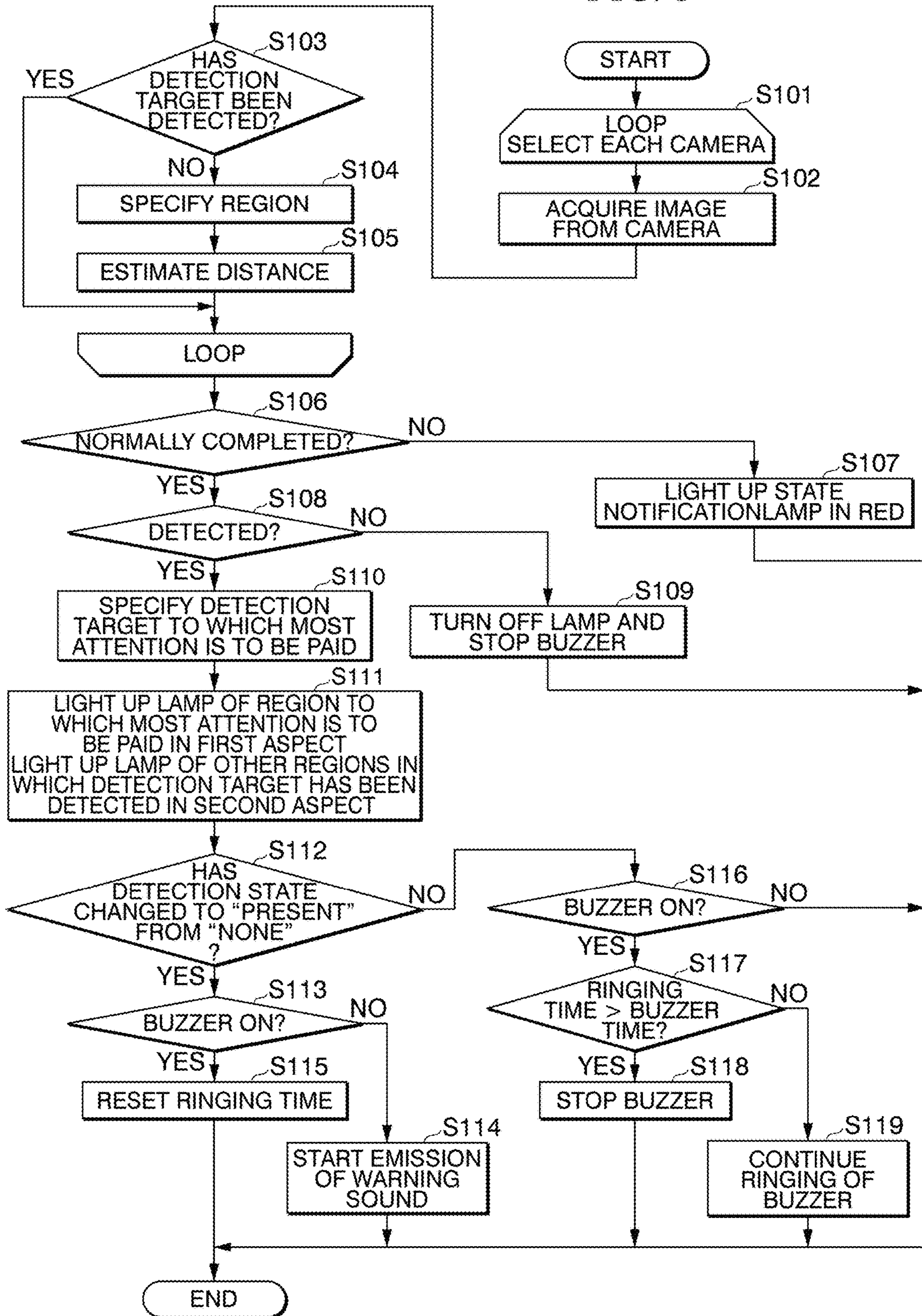

FIG. 9

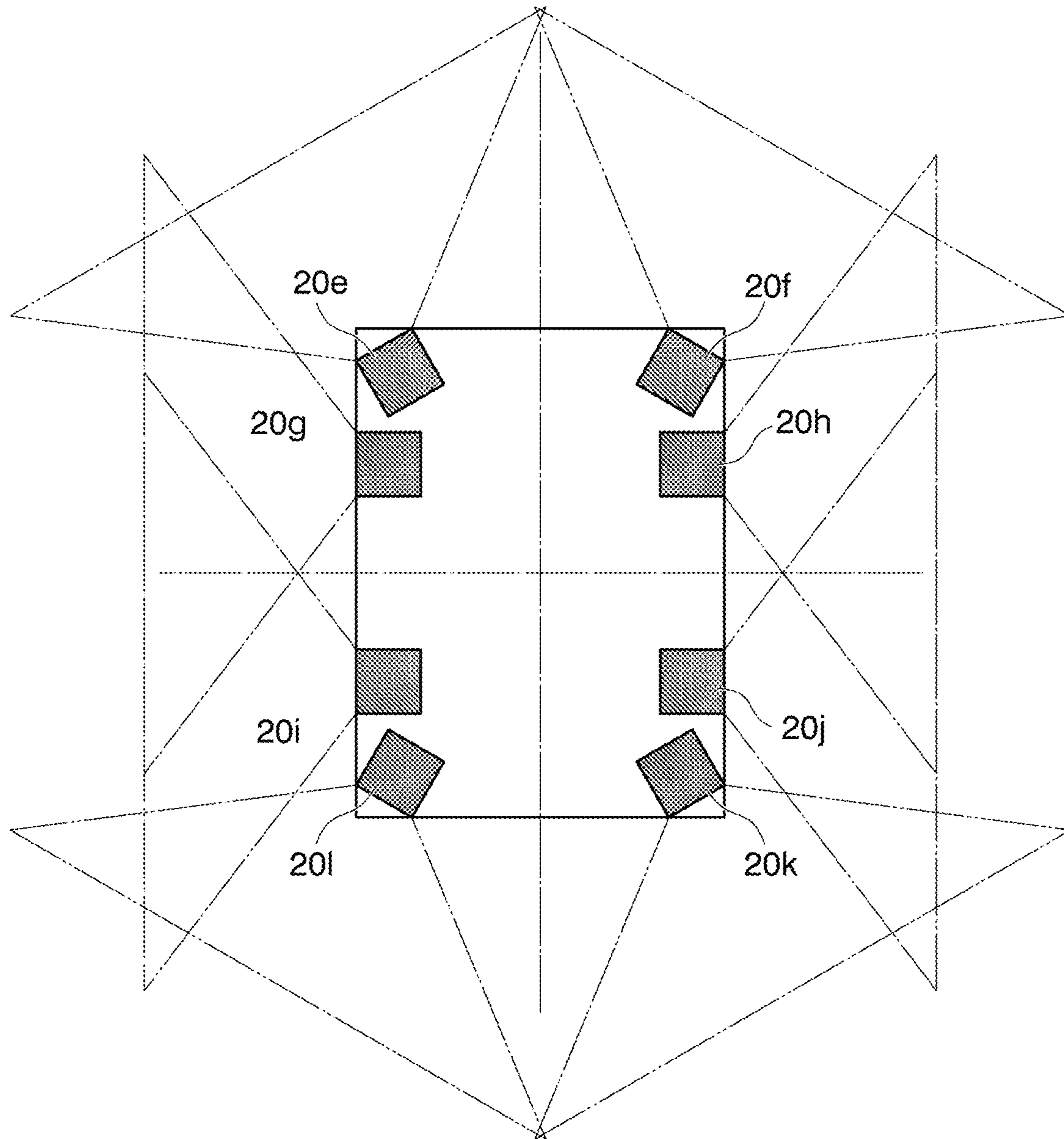
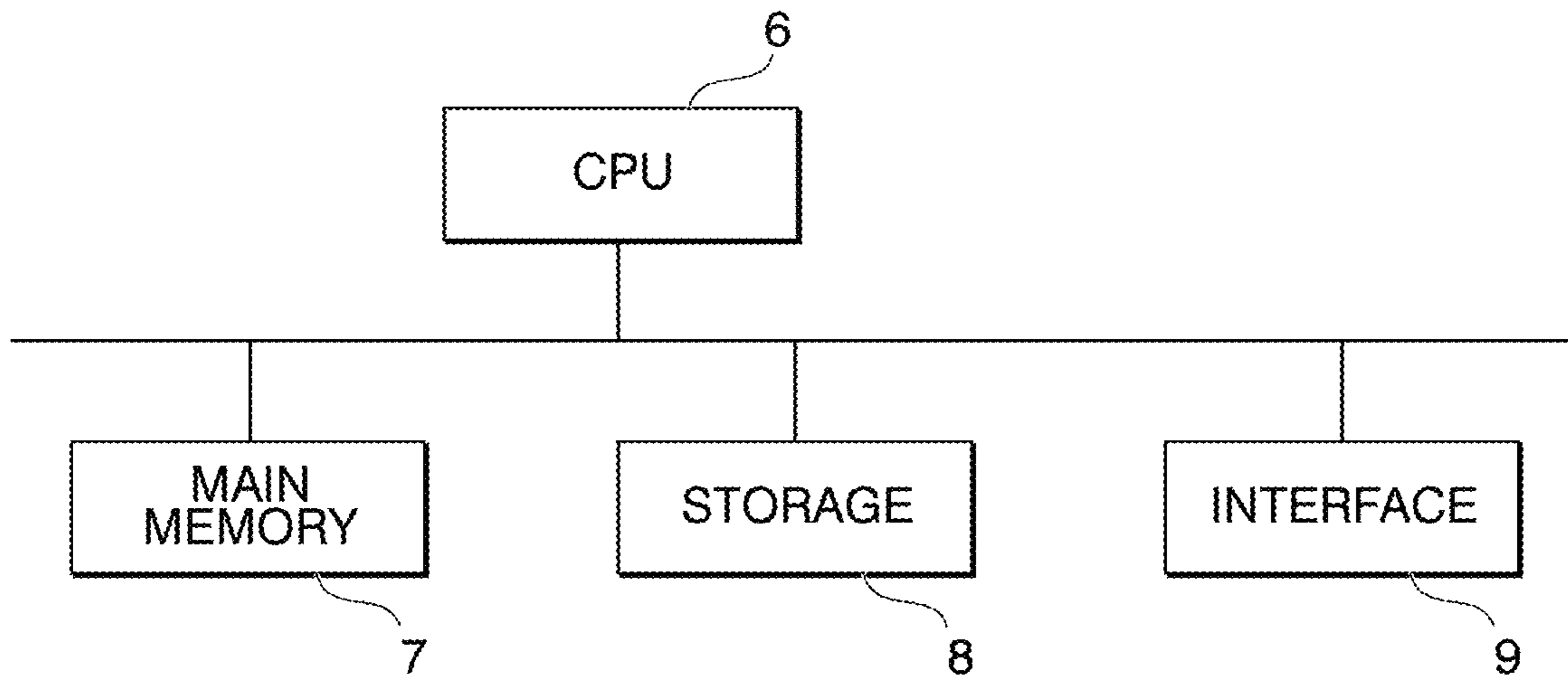

FIG. 10



**CONTROL DEVICE, CONTROL METHOD,
AND COMPUTER READABLE MEDIUM**

BACKGROUND OF THE INVENTION

Field of the Invention

The present invention relates to a control device, a control method, and a non-transitory tangible computer readable medium.

CROSS-REFERENCE TO RELATED
APPLICATION

Priority is claimed on Japanese Patent Application No. 2019-075677, filed Apr. 11, 2019 and 2020-037260, filed Mar. 4, 2020, the contents of which are incorporated herein by references.

Description of Related Art

Industrial vehicles such as forklifts or wheel loaders have different features from general passenger vehicles, such as turning angles of wheels included in a vehicle body or a structure of the vehicle. Therefore, especially for a driver who has little experience in driving the industrial vehicle, a region in which the vehicle actually moves is likely to be different from an expected region when the driver is performing work such as driving or cargo handling of the industrial vehicle, or the driver is likely to be unable to recognize a region that is a blind spot.

Patent Document 1 describes, as a related art, a technology for calling a driver's attention when a forklift moves backwards.

PATENT DOCUMENTS

[Patent Document 1] Japanese Unexamined Patent Application, First Publication No. 2016-222428

SUMMARY OF INVENTION

Incidentally, when a driver is notified of a direction of an obstacle present around an industrial vehicle, the driver cannot understand the direction of the obstacle simply by listening to a sound of the notification.

An object of the present invention is to provide a control device, a control method, and a non-transitory tangible computer readable medium storing a program capable of solving the above problem.

According to a first aspect, a control device includes a specifying unit configured to specify one of a plurality of detection objects on the basis of a state of an industrial vehicle when the plurality of detection objects are detected around the industrial vehicle on the basis of a captured image of an image-capturing device including a plurality of cameras; and a control unit configured to cause a notification to be performed for the one detection object specified by the specifying unit in an aspect different from those of other detected detection objects on the basis of information on the camera that has captured an image of the one detection object specified by the specifying unit and the captured image used for specifying of the detection object.

According to a second aspect, in the control device according to the first aspect, the state includes at least one of a distance between the industrial vehicle and the detection

object, a steering angle of a wheel of the industrial vehicle, and a traveling direction of the industrial vehicle.

According to a third aspect, in the control device according to the first or second aspect, the control unit displays the one detection object specified by the specifying unit on a display unit in an aspect different from those of the other detected detection objects.

According to a fourth aspect, in the control device according to any one of the first to third aspects, the control unit displays the captured image used for specifying of the one detection object on a display unit on the basis of the information on the camera that has captured an image of the one detection object specified by the specifying unit.

According to a fifth aspect, in the control device according to the fourth aspect, the control unit specifies a position of the detection object to be displayed on the display unit on the basis of a position of the detection object in the captured image and the information on the camera.

According to a sixth aspect, the control device according to any one of the first to fifth aspects further includes a surroundings display unit configured to create a bird's-eye view image of surroundings of the industrial vehicle from the captured image of the image-capturing device, wherein the control unit performs a display on the display unit for the one detection object specified by the specifying unit along an outer edge of the surroundings display unit in an aspect different from those of other detected detection objects.

According to a seventh aspect, in the control device according to any one of the first to fifth aspects, the control unit outputs a sound different from the other detection object from a speaker corresponding to a position of the one detection object specified by the specifying unit.

According to an eighth aspect, a control method includes the steps of: specifying one of a plurality of detection objects on the basis of a state of an industrial vehicle when the plurality of detection objects are detected around the industrial vehicle on the basis of a captured image of an image-capturing device including a plurality of cameras; and causing a notification to be performed for the one specified detection object in an aspect different from those of other detected detection objects on the basis of information on the camera that has captured an image of the one specified detection object and the captured image used for specifying of the detection object.

According to a ninth aspect, a non-transitory tangible computer readable medium storing a program causes a computer to: specify one of a plurality of detection objects on the basis of a state of an industrial vehicle when the plurality of detection objects are detected around the industrial vehicle on the basis of a captured image of an image-capturing device including a plurality of cameras; and cause a notification to be performed for the one specified detection object in an aspect different from those of other detected detection objects on the basis of information on the camera that has captured an image of the one specified detection object and the captured image used for specifying of the detection object.

According to the at least one aspect, the driver can intuitively understand directions of obstacles present around an industrial vehicle.

BRIEF DESCRIPTION OF DRAWINGS

FIG. 1 is a diagram showing a configuration of an industrial vehicle according to at least an embodiment of the present invention.

3

FIG. 2 is a schematic diagram in a case in which the industrial vehicle according to at least an embodiment of the present invention is overlooked from directly above.

FIG. 3 is a diagram showing a display example of a display unit according to at least an embodiment of the present invention.

FIG. 4 is a diagram showing a configuration of a control device according to at least an embodiment of the present invention.

FIG. 5 is a diagram showing a processing flow of an industrial vehicle according to at least an embodiment of the present invention.

FIG. 6 is an external view of a detection object notification system according to at least an embodiment of the present invention.

FIG. 7 shows an example of an image that is displayed on a surroundings monitoring device according to at least an embodiment of the present invention.

FIG. 8 is a diagram showing a processing flow of the industrial vehicle according to at least an embodiment of the present invention.

FIG. 9 is a diagram showing a camera arrangement of the industrial vehicle according to at least an embodiment of the present invention.

FIG. 10 is a schematic block diagram showing a configuration of a computer according to at least an embodiment.

DETAILED DESCRIPTION OF INVENTION

First Embodiment

Hereinafter, an industrial vehicle **1** according to a first embodiment of the present invention will be described.

The industrial vehicle **1** is, for example, a forklift as shown in FIG. 1. However, the industrial vehicle **1** may be a construction machine such as a wheel loader, a vehicle having a similar mechanism such as a cargo handling apparatus or rear wheel steering, or a vehicle having similar problems.

The industrial vehicle **1** includes an operation device **10**, a first camera **20a**, a second camera **20b**, a third camera **20c**, a fourth camera **20d**, a first speaker **30a**, a second speaker **30b**, a third speaker **30c**, a fourth speaker **30d**, a display unit **40**, and a control device **50**, as shown in FIG. 1.

The first camera **20a**, the second camera **20b**, the third camera **20c**, and the fourth camera **20d** are collectively referred to as an image-capturing device **20**. Further, the first speaker **30a**, the second speaker **30b**, the third speaker **30c**, and the fourth speaker **30d** are collectively referred to as a notification device **30**.

The operation device **10** is a device that receives an operation when a driver performs moving or cargo handling work on the industrial vehicle **1**. For example, the operation device **10** is, for example, a shift lever that determines a forward and backward movement of the industrial vehicle **1**, a steering wheel that determines a steering angle of the industrial vehicle **1**, and an accelerator and a brake for adjusting a speed or acceleration of the industrial vehicle **1**.

The image-capturing device **20** is provided so that a plurality of cameras each capture images of a region in an outer peripheral direction of the industrial vehicle **1** and capture images of all surroundings of the industrial vehicle **1**.

For example, the first camera **20a**, the second camera **20b**, the third camera **20c**, and the fourth camera **20d** are respectively provided on an upper front, upper right, upper rear, and upper left of the industrial vehicle **1**, as shown in FIG.

4

1. For example, the first camera **20a** captures images of a first image-capturing region **A1** shown in FIG. 2. Similarly, the second camera **20b**, the third camera **20c**, and the fourth camera **20d** respectively capture images of a second image-capturing region **A2**, a third image-capturing region **A3**, and a fourth image-capturing region **A4** shown in FIG. 2.

Although cameras are respectively provided on the upper front, upper right, upper rear, and upper left of the industrial vehicle **1** in the first embodiment of the present disclosure, cameras may be provided in different directions in other embodiments. Further, in another embodiment, it is possible to reduce the number of cameras while capturing images of all surroundings of the industrial vehicle **1** using a plurality of cameras including a fisheye lens or the like. Further, the image-capturing device **20** according to another embodiment may capture images of all surroundings of the industrial vehicle **1** using the camera repeating rotation. Further, when there are blind spots in the four cameras, five or more cameras can be provided. Persons are included as detection targets to be detected by these cameras. Here, the blind spot is a region in which a detection target with which the industrial vehicle **1** is likely to come into contact is not captured.

(Notification Device **30**)

The notification device **30** outputs a sound under the control of the control device **50**.

For example, the first speaker **30a**, the second speaker **30b**, the third speaker **30c**, and the fourth speaker **30d** are respectively provided at the right front, the rear right, the rear left, and the left front of the driver's seat, as shown in FIG. 1. When a detection target is detected in an image captured by the image-capturing device **20** by the control device **50**, a speaker provided in a direction corresponding to a position of the detection target outputs a sound.

Thus, the driver can understand in which direction the detection target is present.

Further, when a plurality of detection targets have been detected by the control device **50**, a speaker provided in a direction corresponding to the position of one detection target determined on the basis of a state of the industrial vehicle **1** among the plurality of speakers outputs a different sound (a sound with a different tone, a different volume, or the like) from the sounds output from other speakers. The state of the industrial vehicle **1** is a state including at least one of a distance between the industrial vehicle **1** and the detection target, a steering angle of the industrial vehicle **1**, and a traveling direction of the industrial vehicle **1**. Further, the one detection target determined on the basis of the state of the industrial vehicle **1** is a detection target to which the most attention is to be paid, which has been determined according to at least one of a movement range of the industrial vehicle **1** estimated from the distance between the industrial vehicle **1** and the detection target and the steering angle of the industrial vehicle **1** and a movement range of the industrial vehicle **1** estimated from the traveling direction. Thus, the driver can understand in which direction the detection target to which the most attention is to be paid among the plurality of detection targets is present.

(Display Unit **40**)

The display unit **40** displays information on an image captured by the image-capturing device **20** under the control of the control device **50**. FIG. 3 is a diagram showing a display example of the display unit **40** in the first embodiment. In the embodiment, a display area of the display unit **40** is divided into a region display area **Ra**, a large image display area **Rb**, and a small image display area **Re**.

5

For example, an image of the first image-capturing region A1 captured by the first camera 20a, an image of the second image-capturing region A2 captured by the second camera 20b, an image of the third image-capturing region A3 captured by the third camera 20c, and an image of the fourth image-capturing region A4 captured by the fourth camera 20d are displayed in small size in the small image display area Re of the display unit 40, as shown in FIG. 3.

Further, an image indicating the region in which the detection target has been detected is displayed in the region display area Ra of the display unit 40. The region display area Ra is divided into a first region R1 that is a right front region, a second region R2 that is a left front region, a third region R3 that is a left rear region, and a fourth region R4 that is a right rear region. An image indicating an outer shape of the industrial vehicle 1 is displayed at a center of the region display area Ra, and a camera icon is displayed at a position in the image in which a camera is provided. Specifically, when the detection target is detected in the second region R2 among the first region R1, the second region R2, the third region R3, and the fourth region R4, the display unit 40 displays the second region R2 in the region display area Ra in an aspect different from those of the first region R1, the third region R3, and the fourth region R4 in which no detection target is detected. For example, when a detection target has been detected in left front of the industrial vehicle 1, the second region R2 among the display areas of the display unit 40 lights (the brightness of the second region R2 is made higher than those of other regions). Further, the display unit 40 displays an icon corresponding to the camera that has captured an image of the detection target among camera icons displayed in the region display area Ra in an aspect different from those of icons corresponding to other cameras.

Further, when the detection target is detected in a plurality of regions, the display unit 40 displays a region to which the most attention is to be paid among the plurality of regions in the region display area Ra in an aspect different from those of other regions in which the detection target has been detected. Specifically, when the detection target is detected in the second region R2 and the fourth region R4 among the first region R1, the second region R2, the third region R3, and the fourth region R4 and when the second region R2 is a region to which the most attention is to be paid, the display unit 40 displays the second region R2 in an aspect different from that of the fourth region R4 in the region display area Ra, as shown in FIG. 3. For example, the display unit 40 causes the second region R2 to blink and the fourth region R4 to light up. Further, the display unit 40 enlarges and displays an image including the detection target captured by the camera 20a that has captured an image of the detection target to which the most attention is to be paid in the large image display area Rb, as shown in FIG. 3.

Thus, the driver can understand in which direction the detection target is present. Further, when detection targets are present in a plurality of regions, the driver can intuitively understand the detection target to which the most attention is to be paid.

The detection target to which the most attention is to be paid is specified by the control device 50. A method in which the control device 50 specifies the detection target to which the most attention is to be paid will be described below.

Further, for example, when the display unit 40 enlarges and displays the image of the detected detection target, the display unit 40 may display information of the camera that has captured the image in the large image display area Rb, as shown in FIG. 3. For example, the display unit 40 may

6

display, within the enlarged displayed image, information indicating a camera that has captured the image, such as a “front camera” indicating that the first camera 20a has captured an image, a “right camera” indicating that the second camera 20b has captured an image, a “rear camera” indicating that the third camera 20c has captured an image, and a “left camera” indicating that the fourth camera 20d has captured an image. Thus, the driver can more clearly understand in which direction the detection target to which the most attention is to be paid among the plurality of detection targets is present.

(Control Device 50)

The control device 50 is a device that controls the notification device 30 and the display unit 40 on the basis of the state of the industrial vehicle 1. The control device 50 includes an image analysis unit 501, an operation determination unit 502, an important detection object specifying unit 503 (an example of a specifying unit), a notification control unit 504 (an example of a control unit), a display control unit 505 (an example of a control unit), and a storage unit 506, as shown in FIG. 4.

The image analysis unit 501 determines whether the detection target has been detected in the image captured by the image-capturing device 20.

For example, the image analysis unit 501 stores features of the detection target including a person in advance. The image analysis unit 501 repeatedly acquires the captured images in an order of the first camera 20a, the second camera 20b, the third camera 20c, and the fourth camera 20d. Each time an image is acquired, the image analysis unit 501 determines that the detection target has been detected in the acquired image when the image analysis unit 501 has determined that the detection target including the person stored in advance is included in the acquired image using a pattern recognition technology.

When the detection target has been detected in the acquired image, the image analysis unit 501 specifies on which of right and left sides of the image the detection target has been detected.

For example, when the detection of the detection target in the image is performed using a pattern recognition technology, the image analysis unit 501 specifies on which of the left side and right side of the image the detection target has been detected according to whether a portion of which a degree of matching the feature of the detection target stored in advance is highest is included in the left side or the right side of the image.

Further, when the detection target has been detected in the acquired image, the image analysis unit 501 specifies from which of the first camera 20a, the second camera 20b, the third camera 20c, and the fourth camera 20d the detected image has been acquired.

Further, when the detection target has been detected in the acquired image, the image analysis unit 501 estimates the distance between the detected detection target and the industrial vehicle 1.

For example, the image analysis unit 501 stores an image size (the number of pixels) corresponding to a size of the detection target and estimates the distance between the industrial vehicle 1 and the detection target from a ratio between the stored image size and the size of the detection target (the number of pixels) detected within the image.

Further, for example, image-capturing performance, an installation position in the industrial vehicle 1, and an image-capturing direction of each of the first camera 20a, the second camera 20b, the third camera 20c, and the fourth camera 20d are understood in advance. Therefore, the image

analysis unit **501** can understand an image-capturing range indicated by a distance in a depth direction and a distance in a horizontal direction in advance and can estimate in a range of a distance from the industrial vehicle **1** the captured image is present. That is, the image analysis unit **501** can estimate, in the image captured by the image-capturing device **20**, a distance indicated by one pixel upward from the bottom among up, down, right, and left of the image (that is, the distance in the depth direction), and a distance indicated by one pixel right or left from the center from the center of the bottom of the image, for example. Therefore, the image analysis unit **501** can specify where the detection target has been detected within the image (for example, whether the detection target has been detected at a position shifted by certain pixels upward and shifted by certain pixels left and right with respect to a center of a bottom of the image) to estimate the distance between the industrial vehicle **1** and the detection target.

Further, for example, when the image-capturing device **20** is a stereo camera, the image analysis unit **501** may use a triangulation technology for a pair of captured images at respective image-capturing timings captured by the stereo camera to estimate the distance between the industrial vehicle **1** and the detection target. In addition, the distance between the industrial vehicle **1** and the detection target may be measured by being provided with a distance sensor.

Each time the detection target is detected in the acquired image, the image analysis unit **501** outputs a detection result image, detection position information indicating which of right and left sides of the image the detection target has been detected, first detection camera information indicating the camera that has captured an image in which the detection target is included, and distance information indicating the distance between the industrial vehicle **1** and the detection target, to the important detection object specifying unit **503**.

The operation determination unit **502** specifies content of an operation performed with respect to the industrial vehicle **1** by the driver from a sensor (not shown) provided in the industrial vehicle **1** and a state of the operation device **10**. For example, the operation determination unit **502** acquires a current vehicle speed of the industrial vehicle **1** from a sensor (not shown) provided in the industrial vehicle **1**. Further, the operation determination unit **502** acquires a signal output due to a change in the operation device **10** or periodically acquires a signal indicating the state of the operation device **10**. Here, a vehicle state of the industrial vehicle **1**, which the operation determination unit **502** acquires from a sensor (not shown) provided in the industrial vehicle **1** and from the operation device **10** includes a steering angle of the industrial vehicle **1** when the driver has rotated a steering wheel, a traveling direction of the industrial vehicle **1** when the driver has switched a shift lever between forward and backward movements, and a state in which the driver has depressed an accelerator or a brake, in addition to a vehicle speed.

The important detection object specifying unit **503** acquires the operation information from the operation determination unit **502**. When the important detection object specifying unit **503** has received the detection result image, the detection position information, the first detection camera information, and the distance information from the image analysis unit **501**, the important detection object specifying unit **503** specifies a state of the industrial vehicle **1** on the basis of the operation information and the distance information.

When the important detection object specifying unit **503** specifies the state of the industrial vehicle **1**, the important

detection object specifying unit **503** stores industrial vehicle state information in which a specifying time and the state of the industrial vehicle **1** have been associated with each other, the detection result image, the detection position information, and the first detection camera information in the storage unit **506**, for example.

The important detection object specifying unit **503** determines whether or not the industrial vehicle state information is stored in the storage unit **506** within a time (hereinafter referred to as “within a determination time”) going back to a time necessary for the image-capturing device **20** to capture images of all surroundings of the industrial vehicle **1** from the present time. That is, the industrial vehicle **1** according to the first embodiment includes four cameras. Therefore, when the cameras are selected one by one in a predetermined image acquisition cycle and an image-capturing process is performed, the determination time is four times the image acquisition cycle.

For example, when there is no industrial vehicle state information within the determination time in the storage unit **506**, the important detection object specifying unit **503** determines that the detection target has not been detected within the determination time. On the other hand, when there is industrial vehicle state information within the determination time in the storage unit **506**, the important detection object specifying unit **503** determines that the detection target has been detected. That is, this means that the detection target has been detected once while all surroundings of the industrial vehicle **1** have been captured images. Further, when the other industrial vehicle state information is present within the determination time in the storage unit **506**, the important detection object specifying unit **503** determines that a plurality of detection targets have been detected.

When the important detection object specifying unit **503** has determined that a plurality of detection targets have been detected within the determination time, the important detection object specifying unit **503** specifies the detection target to which the most attention is to be paid among the detection targets in all the surroundings on the basis of the state of the industrial vehicle **1** indicated by the industrial vehicle state information.

For example, the important detection object specifying unit **503** specifies a detection object, which is present at a position closest to the industrial vehicle **1** among detection objects present in the traveling direction of the industrial vehicle **1**, as the detection target to which the most attention is to be paid. When the important detection object specifying unit **503** specifies the detection target to which the most attention is to be paid, the important detection object specifying unit **503** outputs the second detection camera information indicating a camera that has captured an image of the detection target and the detection position information thereof to the notification control unit **504** and the display control unit **505**.

When the important detection object specifying unit **503** has determined that the detection target has been detected only once within the determination time, the important detection object specifying unit **503** outputs the detected camera information as second detection camera information together with the detection position information to the notification control unit **504** and the display control unit **505**.

When the notification control unit **504** has determined that the second detection camera information and the detection position information have been received from the important detection object specifying unit **503**, the notification control unit **504** outputs the sound from the speaker provided in a

direction in which the detection target is present on the basis of the second detection camera information and the detection position information.

Specifically, when the second detection camera information indicates the first camera **20a** and the detection position information indicates that the detection target has been detected on the right side of the image, or when the second detection camera information indicates the second camera **20b** and the detection position information indicates that the detection target has been detected on the left side of the image, the notification control unit **504** controls the notification device **30** so that a sound is output from the first speaker **30a**. When the second detection camera information indicates the second camera **20b** and the detection position information indicates that the detection target has been detected on the right side of the image, or when the second detection camera information indicates the third camera **20c** and the detection position information indicates that the detection target has been detected on the left side of the image, the notification control unit **504** controls the notification device **30** so that a sound is output from the second speaker **30b**.

Similarly, the notification control unit **504** controls the notification device **30** so that a sound is output from the third speaker **30c** and the fourth speaker **30d** on the basis of the second detection camera information and the detection position information.

When the notification control unit **504** determines that the second detection camera information and the detection position information have been received from the important detection object specifying unit **503** and when a plurality of detection targets have been detected with the determination time on the basis of the industrial vehicle state information recorded in the storage unit **506**, the notification control unit **504** outputs the sound from a plurality of speakers provided in the direction in which the detection target is present.

However, the notification control unit **504** controls the notification device **30** so that the sound to be output from the speaker corresponding to the detection target to which the most attention is to be paid is output in an aspect different from those of the sounds output from the other speakers on the basis of the second detection camera information and the detection position information.

Specifically, when the second detection camera information indicates the first camera **20a** and the detection position information indicates that the detection target has been detected on the right side of the image, or when the second detection camera information indicates the second camera **20b** and the detection position information indicates that the detection target has been detected on the left side of the image, the notification control unit **504** controls the notification device **30** so that the sound output from the first speaker **30a** is output in an aspect different from the sounds output from the other speakers.

Further, similarly, the notification control unit **504** controls the notification device **30** so that the sound is output from the second speaker **30b**, the third speaker **30c**, or the fourth speaker **30d** in an aspect different from those of the sounds output from the other speakers on the basis of the second detection camera information and the detection position information.

The display control unit **505** acquires the image captured images by the image-capturing device **20** and displays the acquired image in the small image display area **Rc** of the display unit **40**.

For example, the display control unit **505** acquires an image which is the same as the image acquired by the image

analysis unit **501** from the image-capturing device **20** in synchronization with a timing at which the image analysis unit **501** repeatedly acquires captured images in an order of the first camera **20a**, the second camera **20b**, the third camera **20c**, and the fourth camera **20d**.

The display control unit **505** displays the image of the first image-capturing region **A1** captured by the first camera **20a**, the image of the second image-capturing region **A2** captured by the second camera **20b**, the image of the third image-capturing region **A3** captured by the third camera **20c**, and the image of the fourth image-capturing region **A4** captured by the fourth camera **20d**, which have been acquired, in a small size in the small image display area **Rc**, as shown in FIG. 3.

When the second detection camera information and the detection position information have been acquired from the important detection object specifying unit **503**, the display control unit **505** displays the region in which the detection target has been detected in the region display area **Ra** of the display unit **40** in an aspect different from that of the region in which the detection target has not been detected on the basis of the second detection camera information and the detection position information.

For example, when the detection target has been detected in the second region **R2** among the first region **R1**, the second region **R2**, the third region **R3**, and the fourth region **R4**, the display control unit **505** displays the second region **R2** in the region display area **Ra** of the display unit **40** in an aspect different from those of the first region **R1**, the third region **R3**, and the fourth region **R4** in which the detection target has not been detected. For example, the display control unit **505** causes the second region **R2** to light up.

Further, the display control unit **505** enlarges the image including the detection target captured by the camera and displays the enlarged image in the large image display area **Rb** of the display unit **40**.

When the display control unit **505** determines that the second detection camera information and the detection position information have been received from the important detection object specifying unit **503** and when a plurality of detection targets have been detected within the determination time on the basis of the industrial vehicle state information recorded in the storage unit **506**, the display control unit **505** displays the region to which the most attention is to be paid among the plurality of regions in the region display area **Ra** of the display unit **40** in an aspect different from those of the other regions in which the detection target has been detected.

Specifically, when the detection target is detected in the second region **R2** and the fourth region **R4** among the first region **R1**, the second region **R2**, the third region **R3**, and the fourth region **R4**, and the second region **R2** is a region to which the most attention is to be paid, the display control unit **505** causes the second region **R2** to blink and causes the fourth region **R4** in the region display area **Ra** to light up. Further, the display control unit **505** enlarges the image including the detection target captured by the camera **20a** that has captured an image of the detection target to which the most attention is to be paid and displays the enlarged image in the large image display area **Rb** of the display unit **40**.

A position of the first speaker **30a** corresponds to the first region **R1**. A position of the second speaker **30b** corresponds to the second region **R2**. A position of the third speaker **30c** corresponds to the third region **R3**. A position of the fourth speaker **30d** corresponds to the fourth region **R4**. Therefore, the display control unit **505** can specify the first region **R1**,

11

the second region R2, the third region R3, and the fourth region R4 corresponding to the position of the detection target by using the same method as the method in which the notification control unit 504 specifies the speaker corresponding to the position of the detection target.

Further, for example, as shown in FIG. 3, when the display control unit 505 enlarges the image of the detected detection target and displays the image in the large image display area Rb of the display unit 40 as shown in FIG. 3, the display control unit 505 may display, in the large image display area Rb on the display unit 40, information indicating a camera that has captured the image, such as the “front camera” indicating that the first camera 20a has captured an image, the “right camera” indicating that the second camera 20b has captured an image, the “rear camera” indicating that the third camera 20c has captured an image, and the “left camera” indicating that the fourth camera 20d has captured an image.

The storage unit 506 stores various types of information necessary for a process that is performed by the control device 50.

For example, the storage unit 506 stores industrial vehicle state information in which a time and the state of the industrial vehicle 1 are associated with each other, an image of a detection result, the detection position information, and the first detection camera information.

(Operation of Industrial Vehicle 1)

Next, a process that is performed by the industrial vehicle 1 will be described. Here, a processing flow of the control device 50 shown in FIG. 5 will be described.

The control device 50 executes a process shown in FIG. 5 in a predetermined image acquisition cycle. It is assumed that the image-capturing device 20 captures images of all surroundings of the industrial vehicle 1. The image analysis unit 501 of the control device 50 specifies one camera for capturing images in an order of the first camera 20a, the second camera 20b, the third camera 20c, and the fourth camera 20d (step S1). The image analysis unit 501 acquires an image from the specified camera (step S2). Further, the display control unit 505 displays the acquired image at a predetermined position in the small image display area Rc of the display unit 40 according to the camera that has captured the acquired image (step S3).

The image analysis unit 501 compares a feature of the detection target stored in advance with the image captured by the image-capturing device 20 and determines whether the detection target has been detected in the image (step S4).

When the image analysis unit 501 does not detect the detection target in the acquired image (NO in step S1), the image analysis unit 501 jumps to step S11.

Further, when the image analysis unit 501 detects the detection target in the acquired image (YES in step S1), the image analysis unit 501 specifies on which of the left and right sides in the image the detection target has been detected (step S5).

For example, when the detection target is detected in the image using a pattern recognition technology, the image analysis unit 501 determines on which of the left side and right side of the image the detection target has been detected according to whether a portion matching the feature of the detection target stored in advance is included in the left side or the right side of the image.

Then, the image analysis unit 501 acquires information on the camera specified in step S1 (imaging performance, an installation position in the industrial vehicle 1, and an imaging direction) (step S6).

12

Further, when the detection target has been detected in the acquired image, the image analysis unit 501 estimates the distance between the detected detection target and the industrial vehicle 1 on the basis of the image acquired in step S2 (step S7).

For example, the image analysis unit 501 can store an image size (the number of pixels) corresponding to the size of the detection target and estimate the distance between the industrial vehicle 1 and the detection target from a ratio between the stored image size and the size of the detection target (the number of pixels) detected within the image.

Each time the detection target is detected in the acquired image, the image analysis unit 501 outputs the detection result image, the detection position information indicating which of right and left sides of the image the detection target has been detected, the first detection camera information indicating the camera that has captured the image in which the detection target is included, and the distance information indicating the distance between the industrial vehicle 1 and the detection target, to the important detection object specifying unit 503.

The important detection object specifying unit 503 acquires the operation information from the operation determination unit 502 (step S8). The operation determination unit 502 specifies the content of the operation performed with respect to the industrial vehicle 1 by the driver from a sensor (not shown) provided in the industrial vehicle 1 and the state of the operation device 10.

The important detection object specifying unit 503 specifies the state of the industrial vehicle 1 on the basis of the operation information and the distance information (step S9) and stores the specifying time, the industrial vehicle state information, the detection result image, the detection position information, and the first detection camera information in the storage unit 506 (step S10). Then, the important detection object specifying unit 503 determines whether or not the detection target has been detected within a determination time on the basis of information in the storage unit 506 (step S11). The determination time is four times the image acquisition cycle. That is, the important detection object specifying unit 503 determines whether or not the detection target has been detected in the image acquired in step S2 and the images captured by the three other cameras acquired before that.

When the plurality of detection targets have been detected within the determination time (plurality in step S11), the important detection object specifying unit 503 generates second detection camera information indicating the camera that has captured an image of the detection target to which the most attention is to be paid (step S12). When the detection target has been detected only once within the determination time (one in step S11), the important detection object specifying unit 503 sets the camera that has captured an image of the detected detection target as the second detection camera information (step S13). When no detection target has been detected within the determination time (No in step S11), notification, such as the notification by the notification control unit 504 and the display by the display control unit 505, is stopped (step S14).

The important detection object specifying unit 503 outputs the second detection camera information and the detection position information to the notification control unit 504 and the display control unit 505.

When the plurality of detection targets have been detected within the determination time (plurality in step S11), the notification control unit 504 outputs sounds from a plurality of speakers provided in the direction in which the detection

target is present. In this case, the notification control unit **504** sets an aspect of the sound output from the speaker corresponding to the detection target to which the most attention is to be paid to an aspect different from that of the sound output from the other speakers (step **S15**). When the detection target has been detected only once within the determination time (one in step **S11**), the notification control unit **504** outputs a sound from a speaker provided in the direction in which the detection target is present (step **S16**).

When the plurality of detection targets have been detected within the determination time (the plurality in step **S11**), the display control unit **505** displays the plurality of regions in which the detection targets are detected in an aspect different from those of the regions in which the detection targets are not detected. In this case, the display control unit **505** displays a region corresponding to the detection target to which the most attention is to be paid in an aspect different from other regions in which the detection target has been detected (step **S17**). When the display control unit **505** has detected the detection target only once within the determination time (one in step **S11**), the display control unit **505** displays the region in which the detection target has been detected in an aspect different from that of the region in which the detection target has not been detected (step **S18**).

The display control unit **505** enlarges the image captured by the camera indicated by the second detection camera information generated in step **S12** or step **S13** and displays the enlarged image in the large image display area **Rb** of the display unit **40**. In this case, the display control unit **505** displays the information of a camera that has captured the image in the enlarged displayed image (step **S19**).

(Operations and Effects)

The industrial vehicle **1** according to an embodiment of the present invention has been described above.

In the control device **50** of the industrial vehicle **1** according to the embodiment of the present invention, when a plurality of detection targets have been detected around the industrial vehicle **1**, the important detection object specifying unit **503** specifies one of the plurality of detection targets on the basis of a state of the industrial vehicle **1**. The notification control unit **504** and the display control unit **505** cause the one specified detection target to be notified in an aspect different from those of the other detected detection targets.

Thus, the driver can intuitively understand a position at which a specific detection target is present as compared with a case in which the driver understands that the detection target has been detected by listening to the sound and then understands a position at which a detection target is present by looking at a display on a monitor.

Specifically, when a plurality of detection targets have been detected, the notification control unit **504** notifies of the detection target to which the most attention is to be paid in an aspect different from those of other detection targets using a notification device **30** so that the driver can intuitively understand the direction in which the detection target is present just by listening to the sound. Further, when the plurality of detection targets have been detected, the display control unit **505** notifies of the detection target to which the most attention is to be paid in an aspect different from those of the other detection targets using the display unit **40** so that the driver can intuitively understand the direction in which the detection target is present just by looking at the display.

Further, in this case, the driver can also intuitively understand the detection target to which the most attention is to be paid.

The industrial vehicle **1** according to the first embodiment performs the display of the captured image and the notification of the region in which the detection target has been detected using one component. On the other hand, an industrial vehicle according to the second embodiment separately includes a surroundings monitoring device that is a component that performs a display of a captured image, and a detection object notification device that is a component that performs a notification of a region in which the detection target has been detected. This is because the detected detection target cannot be displayed within the bird's-eye view image in some cases when an image region for creating a bird's-eye view image is narrower than an image region for performing detection in addition to a case in which some users may desire to mount only the surroundings monitoring device. Further, this is because, even when the detection target can be displayed within the bird's-eye view image, the detection target cannot be appropriately detected or an appropriate display cannot be performed, for example, due to great change in a shape of the detection target when the bird's-eye view image is created.

FIG. **6** is an external view of a detection object notification system **200** according to the second embodiment. The industrial vehicle **1** according to the second embodiment includes the detection object notification system **200** shown in FIG. **6** in place of the first speaker **30a**, the second speaker **30b**, the third speaker **30c**, the fourth speaker **30d**, the display unit **40**, and the control device **50** according to the first embodiment.

The detection object notification system **200** includes a surroundings monitoring device **210** and a detection object notification device **220**.

The surroundings monitoring device **210** converts the images captured by the first camera **20a**, the second camera **20b**, the third camera **20c**, and the fourth camera **20d** into the bird's-eye view image and displays the bird's-eye view image. An image showing the industrial vehicle **1** is displayed at a center of the bird's-eye view image. The detection object notification device **220** is configured as a housing that covers the surroundings monitoring device **210** from above. The detection object notification device **220** notifies a user of the presence of the detection target near the industrial vehicle **1**.

The surroundings monitoring device **210** and the detection object notification device **220** operate separately. That is, the surroundings monitoring device **210** does not control the detection object notification device **220**, and the detection object notification device **220** does not control the surroundings monitoring device **210**.

(Surroundings Monitoring Device **210**)

FIG. **7** is an example of an image that is displayed on the surroundings monitoring device **210** according to the second embodiment. The surroundings monitoring device **210** displays a bird's-eye view image **P1** generated by processing the images captured by the first camera **20a**, the second camera **20b**, the third camera **20c**, and the fourth camera **20d**, and an original image **P2** captured by any one of the first camera **20a**, the second camera **20b**, the third camera **20c**, and the fourth camera **20d**. The original image **P2** may be displayed rotated or inverted according to the camera that has been captured. For example, the surroundings monitoring device **210** displays the original image **P2** captured by the third camera **20a** that captures an image of a rear region in an upside down state so that the user can easily understand that the rear region is captured in the original image **P2**.

In the embodiment, in the image captured by each camera, a portion used for detection and a portion used for a display may be different. For example, the detection object notification device **220** performs detection using an entire region of the image, whereas the surroundings monitoring device **210** may trim a portion of the image to generate the bird's-eye view image P1.

(Detection Object Notification Device **220**)

The detection object notification device **220** includes a housing unit **221**, a first region lamp **222a**, a second region lamp **222b**, a third region lamp **222c**, a fourth region lamp **222d**, a state notification lamp **223**, a buzzer **224**, and a control device **225**. The first region lamp **222a**, the second region lamp **222b**, the third region lamp **222c**, the fourth region lamp **222d**, and the state notification lamp **223** are examples of a display unit.

The housing unit **221** is a rectangular parallelepiped housing and is provided to cover the surroundings monitoring device **210** from above. A rectangular opening is provided in a portion corresponding to a display of the surroundings monitoring device **210** on a front surface of the housing unit **221**.

The first region lamp **222a** is an L-shaped lamp. The first region lamp **222a** is provided to surround an upper right portion of an opening of the housing unit **221**.

The second region lamp **222b** is an L-shaped lamp. The second region lamp **222b** is provided to surround an upper left portion of the opening of the housing unit **221**.

The third region lamp **222c** is an L-shaped lamp. The third region lamp **222c** is provided to surround a lower left portion of the opening of the housing unit **221**.

The fourth region lamp **222d** is an L-shaped lamp. The fourth region lamp **222d** is provided to surround a lower right portion of the opening of the housing unit **221**.

The state notification lamp **223** is provided between the first region lamp **222a** and the second region lamp **222b**. The state notification lamp **223** indicates a state of the detection object notification device **220**. For example, when the detection object notification device **220** is operating normally, the state notification lamp **223** lights up in green. Further, when a detection function of the detection target of the detection object notification device **220** is not operating normally, the state notification lamp **223** lights up in red. Further, when the detection object notification device **220** is not operating, the state notification lamp **223** is turned off.

The buzzer **224** emits a warning sound when the detection target has been detected by the control device **225**.

The first region lamp **222a**, the second region lamp **222b**, the third region lamp **222c**, the fourth region lamp **222d**, and the state notification lamp **223** are configured of, for example, LEDs.

The control device **225** is provided inside the housing unit **221**. The control device **225** controls the first region lamp **222a**, the second region lamp **222b**, the third region lamp **222c**, the fourth region lamp **222d**, the state notification lamp **223**, and the buzzer **224**.

The control device **225** according to the second embodiment has the same configuration as that of the control device **50** according to the first embodiment. That is, the control device **225** includes the image analysis unit **501**, the operation determination unit **502**, the important detection object specifying unit **503**, the notification control unit **504**, the display control unit **505**, and the storage unit **506**. On the other hand, the control device **225** according to the second embodiment operates differently from the control device **50** according to the first embodiment.

(Operation of Detection Object Notification Device **220**)

When the control device **225** is activated, the display control unit **505** causes the state notification lamp **223** to light up in green. The control device **225** executes a process shown in FIG. **8** for each determination time.

First, the image analysis unit **501** of the control device **225** selects the first camera **20a**, the second camera **20b**, the third camera **20c**, and the fourth camera **20d** one by one in each image acquisition cycle (step **S101**) and performs processes of steps **S102** to **S105** below on the selected camera.

The image analysis unit **501** acquires the image captured by the camera selected in step **S101** (step **S102**). The image analysis unit **501** analyzes the acquired image and determines whether or not the detection target is captured in the image (step **S103**). That is, the image analysis unit **501** determines whether the detection target has been detected from the acquired image. When the detection target has been detected from the image (step **S103 YES**), the image analysis unit **501** specifies the region in which the detection target has been detected on the basis of a position at which the detection target is captured in the image (step **S104**). The image analysis unit **501** estimates the distance between the industrial vehicle **1** and the detection target on the basis of the acquired image and the information on the camera selected in step **S101** (step **S105**).

When the image analysis unit **501** performs a detection target detection process on the image captured by each camera, the image analysis unit **501** determines whether or not the image analysis has been normally completed for all the captured images (step **S106**). When the image analysis has abnormally ended for at least one captured image (NO in step **S106**), the display control unit **505** causes the state notification lamp **223** to light up in red (step **S107**) and ends the process. Accordingly, even in a state in which none of the first region lamp **222a**, the second region lamp **222b**, the third region lamp **222c**, and the fourth region lamp **222d** are lit up, the user can recognize that this is not because there is no detection target but because a detection function does not work normally.

When the image analysis has been normally completed for all the captured images (YES in step **S106**), the image analysis unit **501** determines whether or not the detection target has been detected in at least one of the first region **R1**, the second region **R2**, the third region **R3**, and the fourth region **R4** (step **S108**).

When the detection target has not been detected in any of the first region **R1**, the second region **R2**, the third region **R3**, and the fourth region **R4** (NO in step **S108**), the display control unit **505** causes all of the first region lamp **222a**, the second region lamp **222b**, the third region lamp **222c**, and the fourth region lamp **222d** to be turned off. Further, the notification control unit **504** stops ringing of the buzzer **224** (step **S109**) and ends the process.

When the detection target has been detected in at least one of the first region **R1**, the second region **R2**, the third region **R3**, and the fourth region **R4** (YES in step **S108**), the important detection object specifying unit **503** specifies the region, in which the distance specified in step **S105** is shortest among the regions in which the detection target has been detected, as a region in which the detection target to which the most attention is to be paid has been detected (step **S110**).

The display control unit **505** causes the region specified in step **S110** to light up in a first aspect and cause the other regions in which the detection target has been detected to light up in a second aspect (step **S111**). For example, the

display control unit **505** may cause the region specified in step **S110** to light up with relatively high brightness and cause the other regions in which the detection target has been detected to light up with relatively low brightness. Further, for example, the display control unit **505** may cause the region specified in step **S110** to light up in red and cause the other regions in which the detection target has been detected to light up in yellow. Further, for example, the display control unit **505** may cause the region specified in step **S110** to light up and cause the other regions in which the detection target has been detected to blink.

The image analysis unit **501** determines whether or not the region that has changed from a state in which the detection target has not been detected to a state in which the detection target has been detected is present among the first region **R1**, the second region **R2**, the third region **R3**, and the fourth region **R4** (step **S112**). When there is at least one region that has changed from a state in which the detection target has not been detected to a state in which the detection target has been detected (YES in step **S112**), the notification control unit **504** determines whether or not the buzzer **224** has already emitted a warning sound (step **S113**).

When the buzzer **224** does not emit the warning sound (NO in step **S113**), the notification control unit **504** causes the buzzer **224** to emit the warning sound, starts measurement of a buzzer ringing time (step **S114**), and ends the process.

On the other hand, when the buzzer **224** has already emitted the warning sound (YES in step **S113**), the notification control unit **504** resets the buzzer ringing time, starts measurement again (step **S115**), and ends the process.

When there is no region that has changed from a state in which the detection target has not been detected to a state in which the detection target has been detected (NO in step **S112**), the notification control unit **504** determines whether or not the buzzer **224** has already emitted the warning sound (step **S116**).

When the buzzer **224** does not emit the warning sound (NO in step **S116**), the notification control unit **504** maintains a state in which the buzzer **224** is stopped and ends the process.

On the other hand, when the buzzer **224** has already emitted a warning sound (YES in step **S116**), the notification control unit **504** determines whether the buzzer ringing time is equal to or longer than a predetermined buzzer time (step **S117**). When the buzzer ringing time is shorter than the predetermined buzzer time (NO in step **S117**), the notification control unit **504** causes the buzzer **224** to continue the emission of the warning sound (step **S118**) and ends the process.

On the other hand, when the buzzer ringing time is equal to or longer than the predetermined buzzer time (YES in step **S117**), the notification control unit **504** stops the buzzer **224** (step **S119**) and ends the process. Thereby, the notification control unit **504** can allow the buzzer to ring again when a new detection target has been detected while preventing the buzzer from continuing to ring while the detection target is continuously detected in one region.
(Operations and Effects)

Thus, in the detection object notification system **200** according to the second embodiment, the lamp **222** of the detection object notification device **220** is provided along an outer periphery of the surroundings monitoring device **210**. Thereby, the detection object notification device **220** can appropriately display a direction of the detection target even when the surroundings monitoring device **210** cannot be controlled.

The industrial vehicle **1** according to the first embodiment includes four cameras. On the other hand, an industrial vehicle **1** according to the third embodiment includes eight cameras. FIG. **9** is a diagram showing a camera arrangement of the industrial vehicle according to the third embodiment.

The industrial vehicle **1** according to the third embodiment includes a camera **20e** that captures an image of a diagonally left front region, a camera **20f** that captures an image of a diagonally right front region, a camera **20g** that captures an image of a left region from the front of a vehicle body, a camera **20h** that captures an image of a right region from the front of the vehicle body, a camera **20i** that captures an image of a left region from the rear of a vehicle body, a camera **20j** that captures an image of a right region from the rear of the vehicle body, a camera **20k** that captures an image of a diagonally left rear region, and a camera **20l** that captures an image of a diagonally right rear region.

An image-capturing range of each camera according to the third embodiment extends over a plurality of regions. On the other hand, a boundary line between two regions in the image is not necessarily a center line of the image. Therefore, the control device **50** according to the third embodiment stores a boundary line partitioning a region for the respective cameras and determines whether the detection target is captured on the left side or captured on the right side of the boundary line to specify a region in which the detection target is present. The boundary line may be set parallel to a Y axis of the image or may be set with an inclination. Further, the boundary may be a straight line or may be a curved line.

Other Embodiments

In the embodiment of the present invention, a case in which the image-capturing device **20** includes the first camera **20a**, the second camera **20b**, the third camera **20c**, and the fourth camera **20d** has been described. However, in another embodiment of the present invention, the image-capturing device **20** may be able to capture images of all surroundings of the industrial vehicle **1** without creating a large blind spot, and the number of cameras included in the image-capturing device **20** and position at which the cameras are provided are not limited.

Further, the blind spot is likely to be large depending on a size of the industrial vehicle **1** or a range being capable of capture images by the cameras, in the four cameras exemplified in the embodiment of the present invention. In such a case, for example, the image-capturing device **20** may include five or more cameras to reduce the blind spot.

In the embodiment of the present invention, a case in which the notification device **30** includes the first speaker **30a**, the second speaker **30b**, the third speaker **30c**, and the fourth speaker **30d** has been described. However, in another embodiment of the present invention, the number of speakers and positions at which the speakers are provided are not limited as long as the notification device **30** is a speaker that outputs a sound in a direction or a region corresponding to a position at which a detection target is present with respect to the industrial vehicle **1** when the detection target has been detected.

In the embodiment of the present invention, a case in which the display control unit **505** displays the image captured by each of the image-capturing devices **20** in a small size has been described. However, in another embodiment of the present invention, when a detection target has

been detected, the display control unit **505** may enlarge and display only an image including the detection target.

In the embodiment of the present invention, a case in which the display control unit **505** displays the image of the rear of the industrial vehicle **1** on the display unit **40** as it is has been described. However, in another embodiment of the present invention, the display control unit **505** may invert the image of the rear of the industrial vehicle **1** laterally and display the resultant image on the display unit **40** (that is, display the image on the display unit like a back monitor). Further, in another embodiment of the present invention, the display control unit **505** may generate a bird's-eye view image (of the vehicle) by processing an image of the surroundings of the industrial vehicle **1** and display the generated bird's-eye view image on the display unit **40**.

In the embodiment of the present invention, a case in which the image analysis unit **501** detects the detection target in the entire acquired image has been described. However, in another embodiment of the present invention, the image analysis unit **501** may detect the detection target only in a portion of the acquired image (for example, a lower half of the image, that is, a half of the image-capturing region close to the industrial vehicle **1**). That is, in another embodiment of the present invention, the image analysis unit **501** may not determine that the detection target is a detection target even when the detection target is captured in regions other than the portion of the acquired image. In this case, the notification control unit **504** performs control so that a sound is output from the speaker because the detection target captured in the image is not determined to be a detection target.

An order of the processes according to the embodiment of the present invention may be changed in a range in which an appropriate process is performed.

Each of the storage unit **506** and other storage devices in the embodiment of the present invention may be included anywhere in a range in which appropriate information transmission and reception are performed. Further, there may be a plurality of storage units **506** and other storage devices in a range in which the appropriate information transmission and reception are performed, and the storage units **506** and other storage devices may store data in a distributive manner.

Although the embodiments of the present invention have been described, the above-described control device **50** and other control devices may include a computer system therein. The steps of the process described above are stored in the form of a program in a computer-readable medium, and a computer reads and executes this program so that the above process is performed. A specific example of the computer is shown below.

FIG. **10** is a schematic block diagram showing a configuration of a computer according to at least an embodiment.

A computer **5** includes a CPU **6**, a main memory **7**, a storage **8**, and an interface **9**, as shown in FIG. **10**.

For example, each of the above-described control device **50** and other control devices is mounted in the computer **5**. An operation of each processing unit described above is stored in the storage **8** in the form of a program. The CPU **6** reads the program from the storage **8**, loads the program in the main memory **7**, and executes the above process according to the program. Further, the CPU **6** secures a storage area corresponding to each of the above-described storage units in the main memory **7** according to the program.

Examples of the storage **8** include a hard disk drive (HDD), a solid state drive (SSD), a magnetic disk, a mag-

neto-optical disc, a compact disc read only memory (CD-ROM), a digital versatile disc read only memory (DVD-ROM), and a semiconductor memory. The storage **8** may be an internal medium directly connected to a bus of the computer **5** or an external medium connected to the computer **5** via the interface **9** or a communication line. Further, when this program is distributed to the computer **5** via a communication line, the computer **5** that has received the program may load the program into the main memory **7** and execute the above process. In at least an embodiment, the storage **8** is a non-transitory tangible computer readable medium.

Further, the above program may realize some of the above-described functions. Further, the above program may be a file capable of realizing the above-described functions in combination with a program previously recorded in a computer system, that is, a differential file (a differential program).

In another embodiment, a control device **127** includes a custom large scale integrated circuit (LSI), such as a programmable logic device (PLD), an application specialized circuit (ASIC), a graphics processing unit (GPU), and a similar processing device, in addition to or in place of the above-described configuration. Examples of the PLD include a programmable array logic (PAL), a generic array logic (GAL), a complex programmable logic device (CPLD), and a field programmable gate array (FPGA). In this case, some or all of the functions realized by the processor may be realized by the integrated circuit.

Several embodiments of the present invention have been described, but these embodiments are examples and do not limit the scope of the invention. Various additions, omissions, substitutions, and changes may be made to these embodiments without departing from the gist of the invention.

EXPLANATION OF REFERENCES

- 1** Industrial vehicle
- 5** Computer
- 6** CPU
- 7** Main memory
- 8** Storage
- 9** Interface
- 10** Operation device
- 20** Image-capturing device
- 20a** First camera
- 20b** Second camera
- 20c** Third camera
- 20d** Fourth camera
- 30** Notification device
- 30a** First speaker
- 30b** Second speaker
- 30c** Third speaker
- 30d** Fourth speaker
- 40** Display unit
- 50** Control device
- 200** Detection object notification system
- 210** Surroundings monitoring device
- 220** Detection object notification device
- 221** housing unit
- 222a** First region lamp
- 222b** Second region lamp
- 222c** Third region lamp
- 222d** Fourth region lamp
- 223** State notification lamp
- 224** Buzzer

21

225 Control device
 501 Image analysis unit
 502 Operation determination unit
 503 Important detection object specifying unit
 504 Notification control unit
 505 Display control unit
 506 Storage unit

What is claimed is:

1. A control device comprising:

a specifying unit configured to specify one of a plurality of detection objects on the basis of a state of an industrial vehicle when the plurality of detection objects are detected around the industrial vehicle on the basis of a captured image of an image-capturing device including a plurality of cameras;

a surroundings display unit including a display that is configured to display a bird's-eye view image of surroundings of the industrial vehicle created from the captured image of the image-capturing device;

a display unit including a plurality of lamps provided along an outer periphery of the display; and

a control unit configured to cause, among the plurality of lamps, one lamp corresponding to a region which is in the bird's-eye view image displayed in the display and in which the image of the one detection object specified by the specifying unit is captured to light up or be turned off in an aspect different from another lamp corresponding to a region in which an image of the other detected detection object is captured on the basis of information on the camera that has captured an image of the one detection object specified by the specifying unit and the captured image used for specifying of the detection object.

2. The control device according to claim 1, wherein the state includes at least one of a distance between the industrial vehicle and the detection object, a steering angle of a wheel of the industrial vehicle, and a traveling direction of the industrial vehicle.

3. The control device according to claim 1, wherein the control unit displays the one detection object specified by the specifying unit on a display unit in an aspect different from those of the other detected detection objects.

4. The control device according to claim 1, wherein the control unit displays the captured image used for specifying of the one detection object on a display unit on the basis of the information on the camera that has captured an image of the one detection object specified by the specifying unit.

5. The control device according to claim 4, wherein the control unit specifies a position of the detection object to be displayed on the display unit on the basis of a position of the detection object in the captured image and the information on the camera.

22

6. The control device according to claim 1, wherein the control unit outputs a sound different from the other detection object from a speaker corresponding to a position of the one detection object specified by the specifying unit.

7. A control method of controlling a detection object notification system including:

a surroundings display unit including a display that is configured to display a bird's-eye view image of surroundings of the industrial vehicle created from a captured image of an image-capturing device including a plurality of cameras; and

a display unit including a plurality of lamps provided along an outer periphery of the display,

the control method comprising the steps of:

specifying one of a plurality of detection objects on the basis of a state of an industrial vehicle when the plurality of detection objects are detected around the industrial vehicle on the basis of the captured image of the image-capturing device; and

causing, among the plurality of lamps, one lamp corresponding to a region which is in the bird's-eye view image displayed in the display and in which the image of the one detection object specified is captured to light up or be turned off in an aspect different from another lamp corresponding to a region in which an image of the other detected detection object is captured on the basis of information on the camera that has captured an image of the one specified detection object and the captured image used for specifying of the detection object.

8. A non-transitory tangible computer readable medium storing a program for causing a computer in a detection object notification system including:

a surroundings display unit including a display that is configured to display a bird's-eye view image of surroundings of the industrial vehicle created from a captured image of an image-capturing device including a plurality of cameras; and

a display unit including a plurality of lamps provided along an outer periphery of the display, to:

specify one of a plurality of detection objects on the basis of a state of an industrial vehicle when the plurality of detection objects are detected around the industrial vehicle on the basis of a captured image of the image-capturing device including the plurality of cameras; and

cause, among the plurality of lamps, one lamp corresponding to a region which is in the bird's-eye view image displayed in the display and in which the image of the one detection object specified is captured to light up or be turned off in an aspect different from another lamp corresponding to a region in which an image of the other detected detection object is captured on the basis of information on the camera that has captured an image of the one specified detection object and the captured image used for specifying of the detection object.

* * * * *