



US011529505B2

(12) **United States Patent**  
**Niven et al.**

(10) **Patent No.:** **US 11,529,505 B2**  
(45) **Date of Patent:** **\*Dec. 20, 2022**

(54) **APPARATUS AND METHOD FOR PUNCTURING THE EPIDERMIS WITH CONTROLLED FLUID DELIVERY**

(71) Applicant: **Rejuvatek Medical Inc.**, Sandy, UT (US)

(72) Inventors: **Gregg D. Niven**, Kaysville, UT (US);  
**Jack H. Savage**, Sandy, UT (US)

(73) Assignee: **Rejuvatek Medical Inc.**, Sandy, UT (US)

(\* ) Notice: Subject to any disclaimer, the term of this patent is extended or adjusted under 35 U.S.C. 154(b) by 194 days.

This patent is subject to a terminal disclaimer.

(21) Appl. No.: **16/832,534**

(22) Filed: **Mar. 27, 2020**

(65) **Prior Publication Data**

US 2020/0222147 A1 Jul. 16, 2020

**Related U.S. Application Data**

(63) Continuation of application No. 15/261,660, filed on Sep. 9, 2016, now Pat. No. 10,610,327.

(Continued)

(51) **Int. Cl.**

*A61M 37/00* (2006.01)

*A61B 90/00* (2016.01)

(Continued)

(52) **U.S. Cl.**

CPC ..... *A61M 37/0084* (2013.01); *A61B 17/00* (2013.01); *A61B 90/39* (2016.02);

(Continued)

(58) **Field of Classification Search**

CPC ..... *A61M 5/46*; *A61M 37/0084*; *A61M 2210/04*; *A61B 2017/00769*; *A61B 17/00*;

(Continued)

(56) **References Cited**

U.S. PATENT DOCUMENTS

2,588,623 A 3/1952 Eliscu  
4,719,825 A \* 1/1988 LaHaye ..... *A61M 37/0076*  
401/172

(Continued)

OTHER PUBLICATIONS

“Manual for Dragonfly X2 Tattoo Machine”, InkMachines, (May 7, 2010), 33 pages, available at [http://www.inkmachines.com/sites/default/files/files/Manual\\_For\\_Dragonfly\\_X2\\_tattoo\\_machine\\_EN\\_rev1.pdf](http://www.inkmachines.com/sites/default/files/files/Manual_For_Dragonfly_X2_tattoo_machine_EN_rev1.pdf).

*Primary Examiner* — Jing Rui Ou

(74) *Attorney, Agent, or Firm* — Gurr Brande & Spendlove, PLLC.; Robert Dan Spendlove

(57) **ABSTRACT**

Embodiments of an apparatus include a needle cartridge configured to attach to and interface with an actuating device. The needle cartridge includes a housing, a needle group assembly, and a fluid port. The housing forms a cavity and includes a first aperture and a second aperture opposite the first aperture. The needle group assembly includes a needle and a needle holder. The needle group assembly is configured to move in a reciprocating motion relative to the housing along an axis from the first aperture to the second aperture. During the reciprocating motion, the needle fully retracts into the cavity through the first aperture. The fluid port is integrated with the housing and includes a hollow projection forming a conduit and extending away from the housing. The fluid port includes a third aperture, wherein the fluid port is configured to interface with a fluid delivery system.

**13 Claims, 8 Drawing Sheets**

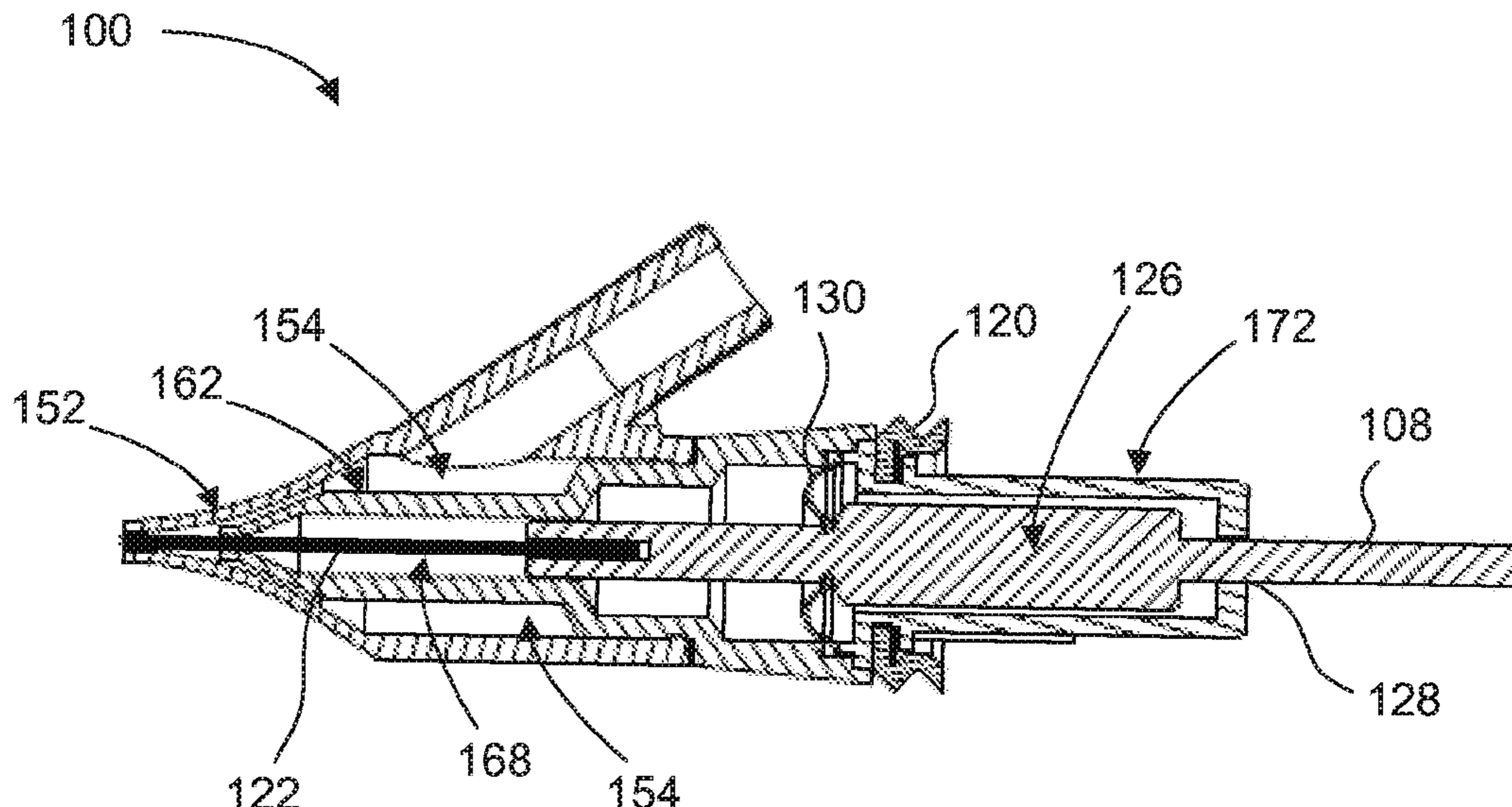

**Related U.S. Application Data**

- (60) Provisional application No. 62/216,206, filed on Sep. 9, 2015.
- (51) **Int. Cl.**  
*A61B 17/00* (2006.01)  
*A61M 5/46* (2006.01)  
*A61B 34/10* (2016.01)
- (52) **U.S. Cl.**  
 CPC ..... *A61M 5/46* (2013.01); *A61B 2017/00769* (2013.01); *A61B 2034/102* (2016.02); *A61B 2090/395* (2016.02); *A61M 2210/04* (2013.01)
- (58) **Field of Classification Search**  
 CPC ..... A61B 90/39; A61B 2034/102; A61B 2090/395  
 See application file for complete search history.

(56) **References Cited**

U.S. PATENT DOCUMENTS

- 6,505,530 B2 1/2003 Adler et al.
- 6,585,694 B1 7/2003 Smith et al.
- 8,663,162 B2 3/2014 Bunting et al.
- 9,707,384 B2 \* 7/2017 La Fontaine ..... A61M 37/0076
- 9,707,385 B1 7/2017 Chen et al.

- 9,750,528 B2 9/2017 Scherkowski
- 2002/0069726 A1 \* 6/2002 Adler ..... A61M 37/0076  
81/9.22
- 2002/0193752 A1 12/2002 Lynn
- 2003/0171767 A1 9/2003 Koplen
- 2003/0195542 A1 10/2003 Lee
- 2004/0116953 A1 \* 6/2004 Dixon ..... A61M 37/0076  
606/186
- 2004/0186501 A1 9/2004 Su
- 2005/0010236 A1 \* 1/2005 Frister ..... A61M 37/0076  
606/116
- 2005/0107738 A1 5/2005 Slater et al.
- 2006/0020283 A1 \* 1/2006 Lisec ..... A61M 37/0076  
606/185
- 2008/0208235 A1 8/2008 Ulmer et al.
- 2008/0221548 A1 9/2008 Danenberg et al.
- 2008/0287978 A1 11/2008 Hickman, III
- 2008/0306502 A1 \* 12/2008 Lisec ..... A61M 37/00  
606/186
- 2009/0125050 A1 5/2009 Dixon
- 2010/0191268 A1 \* 7/2010 Lee ..... A61M 37/0084  
606/185
- 2012/0041374 A1 2/2012 Lee
- 2012/0123462 A1 \* 5/2012 Lee ..... A61M 37/0076  
606/185
- 2015/0202420 A1 7/2015 Miller et al.
- 2016/0263365 A1 9/2016 Smith

\* cited by examiner

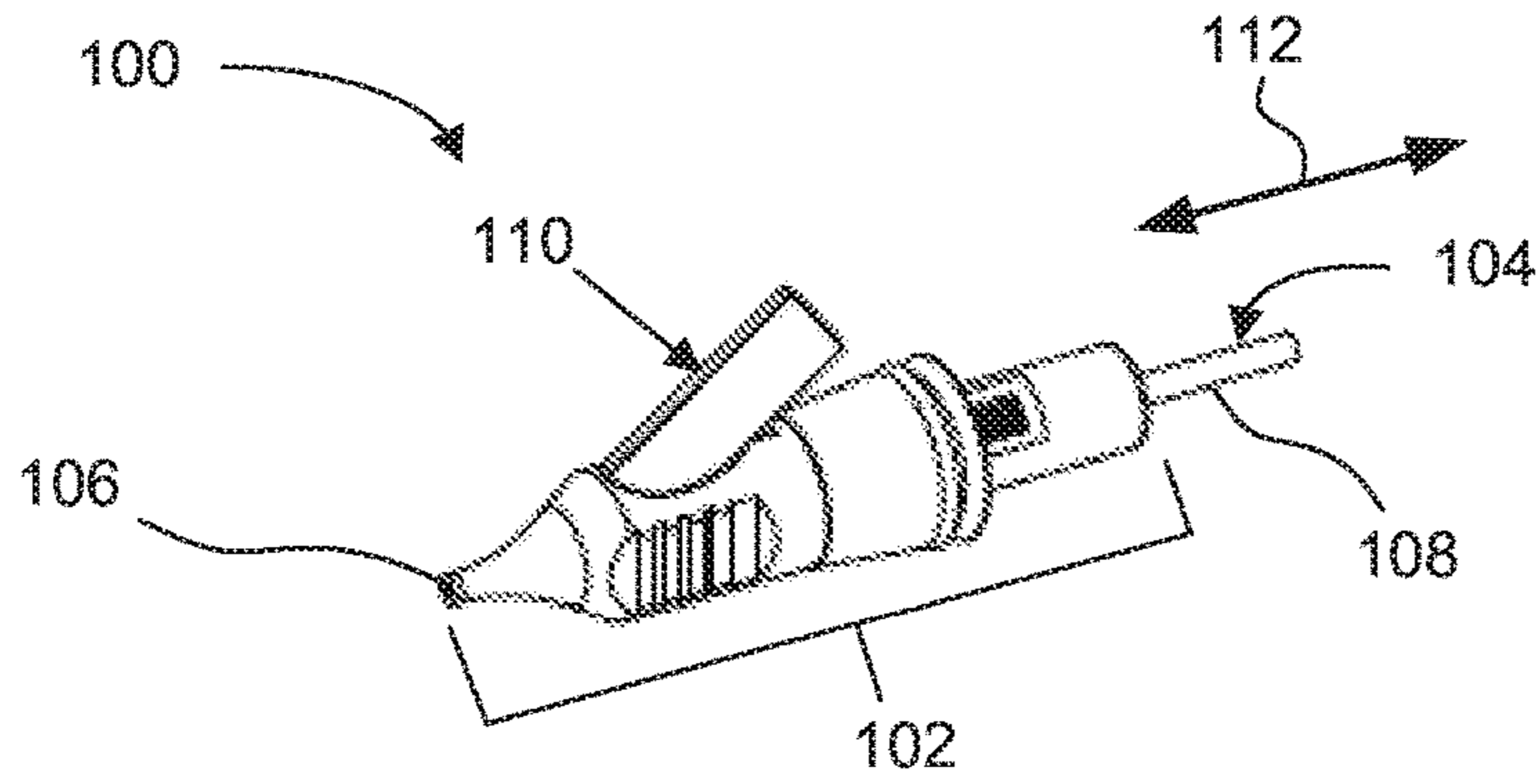

FIG. 1

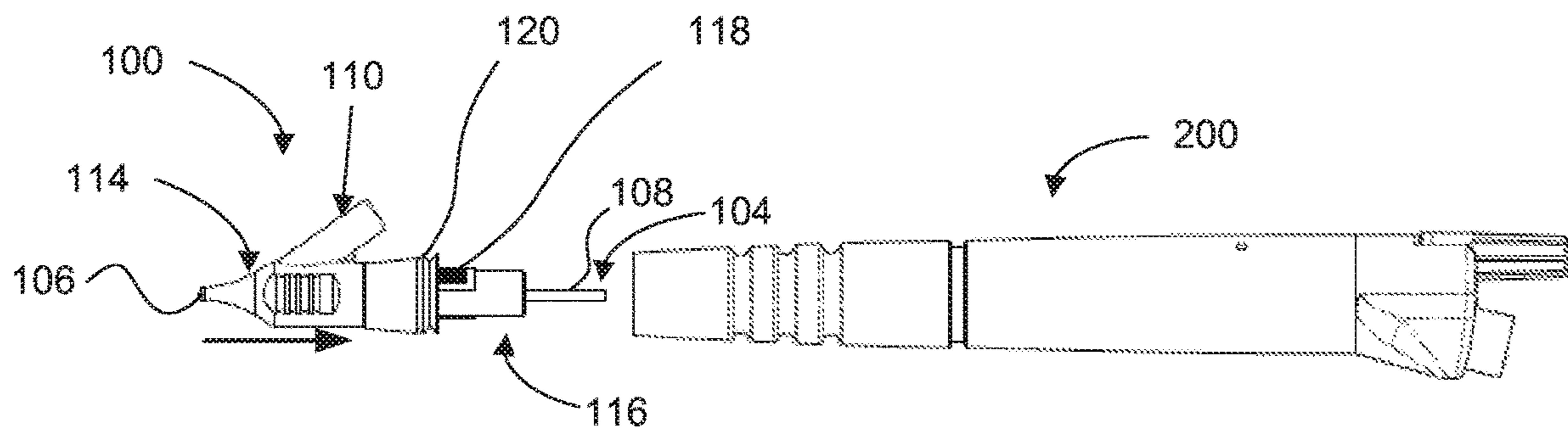

FIG. 2

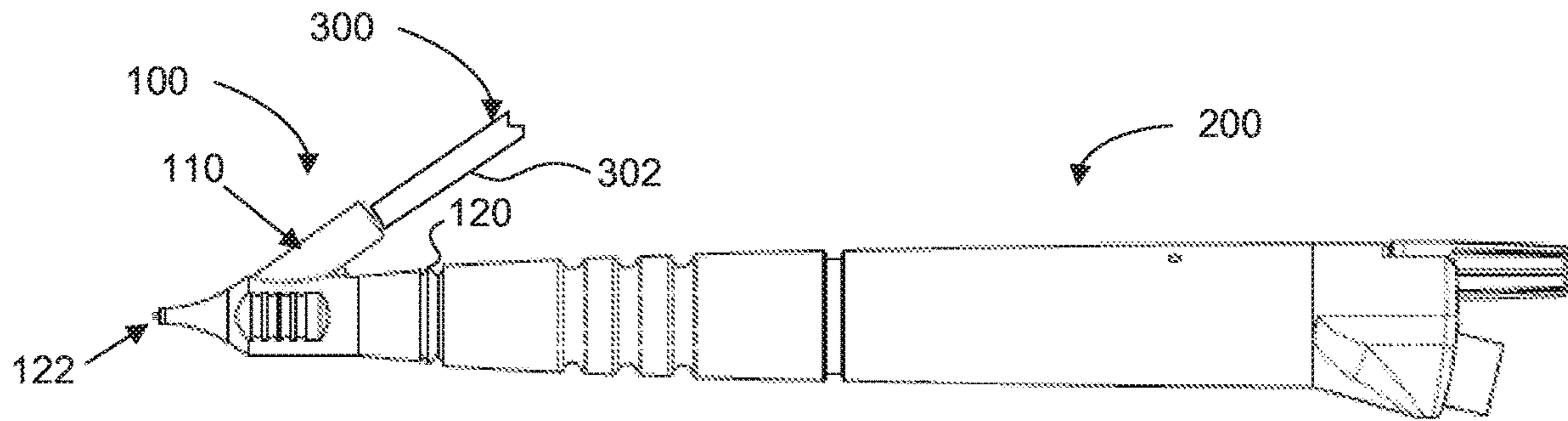

FIG. 3

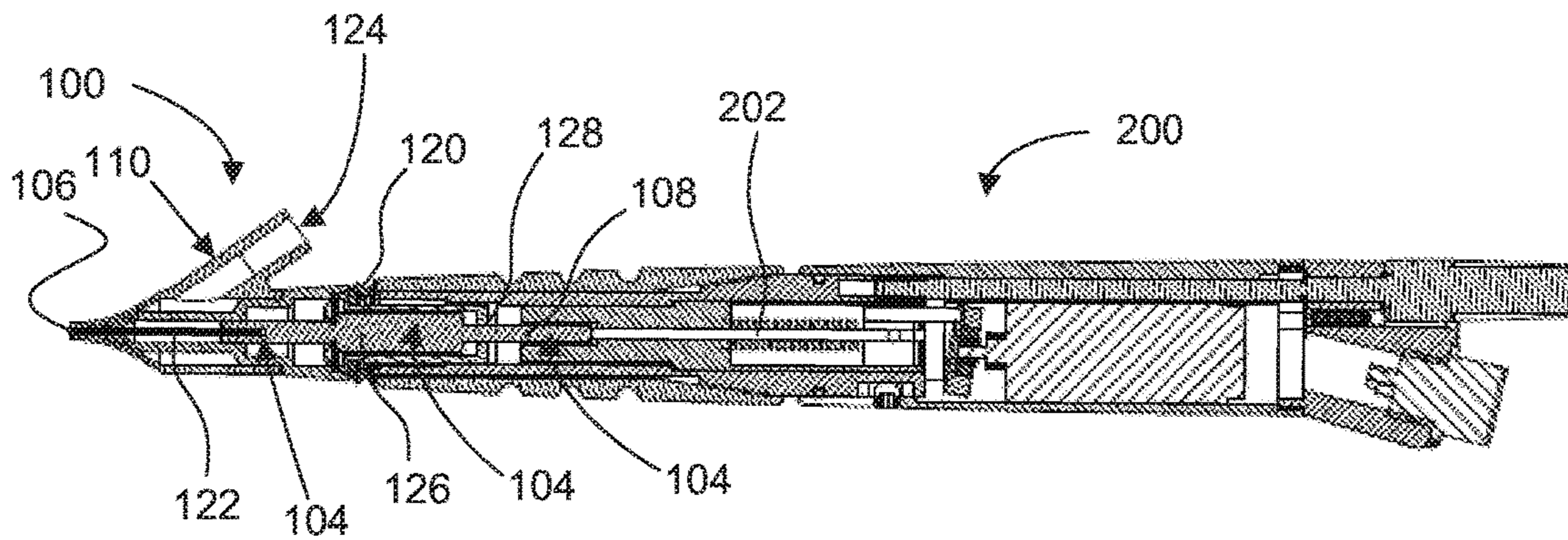

FIG. 4

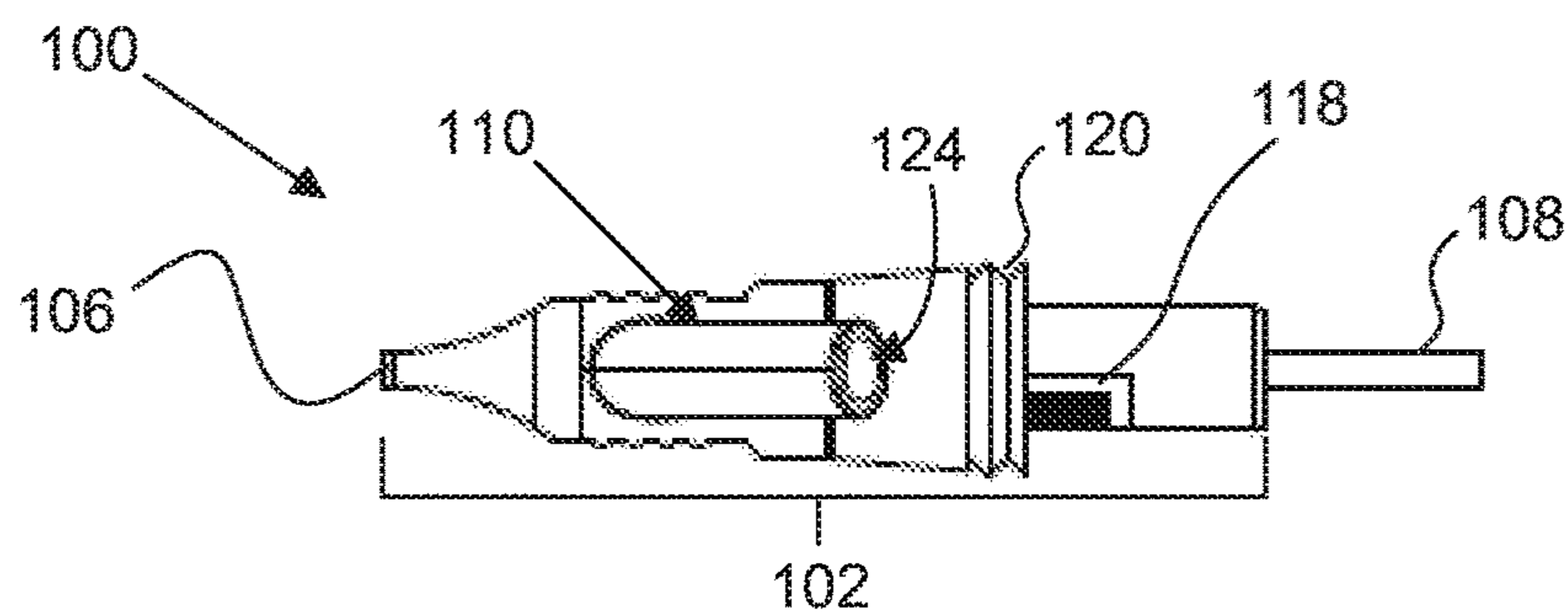

FIG. 5

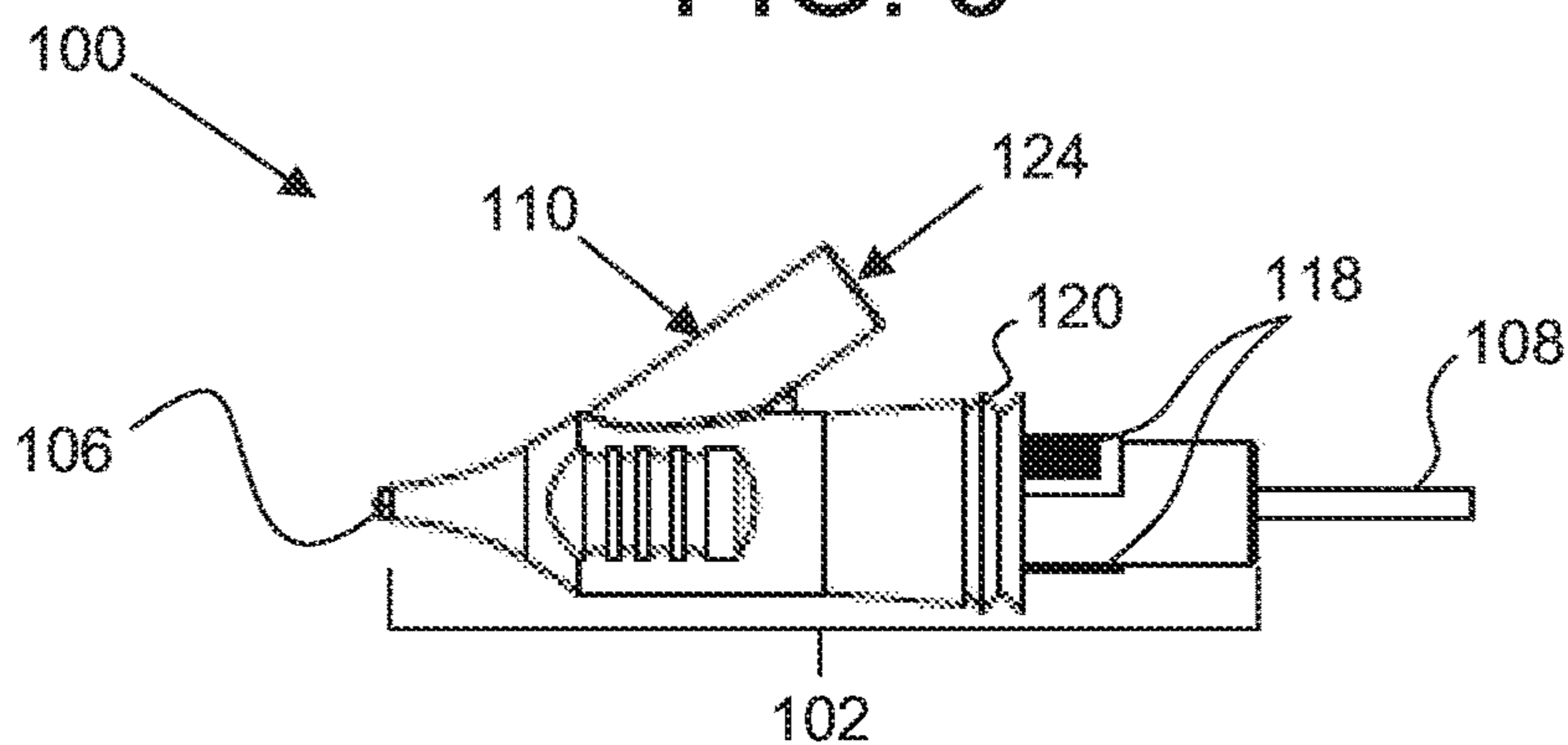

FIG. 6

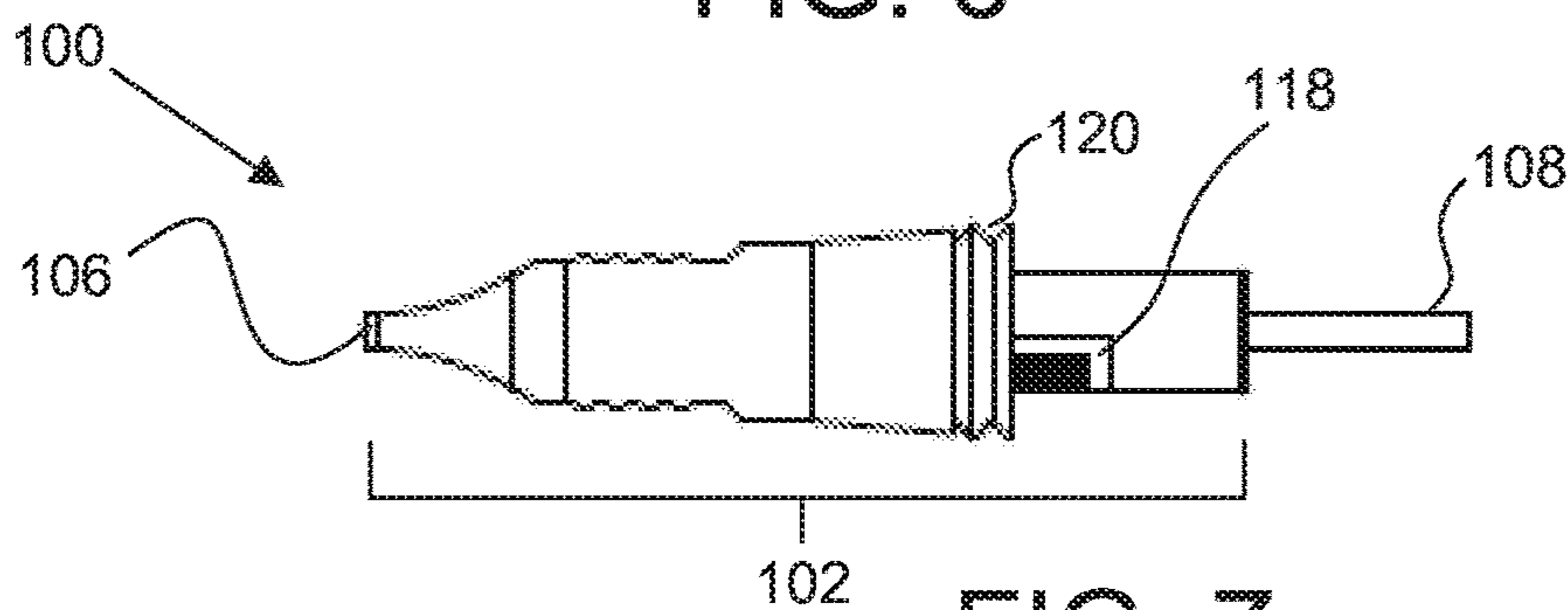

FIG. 7

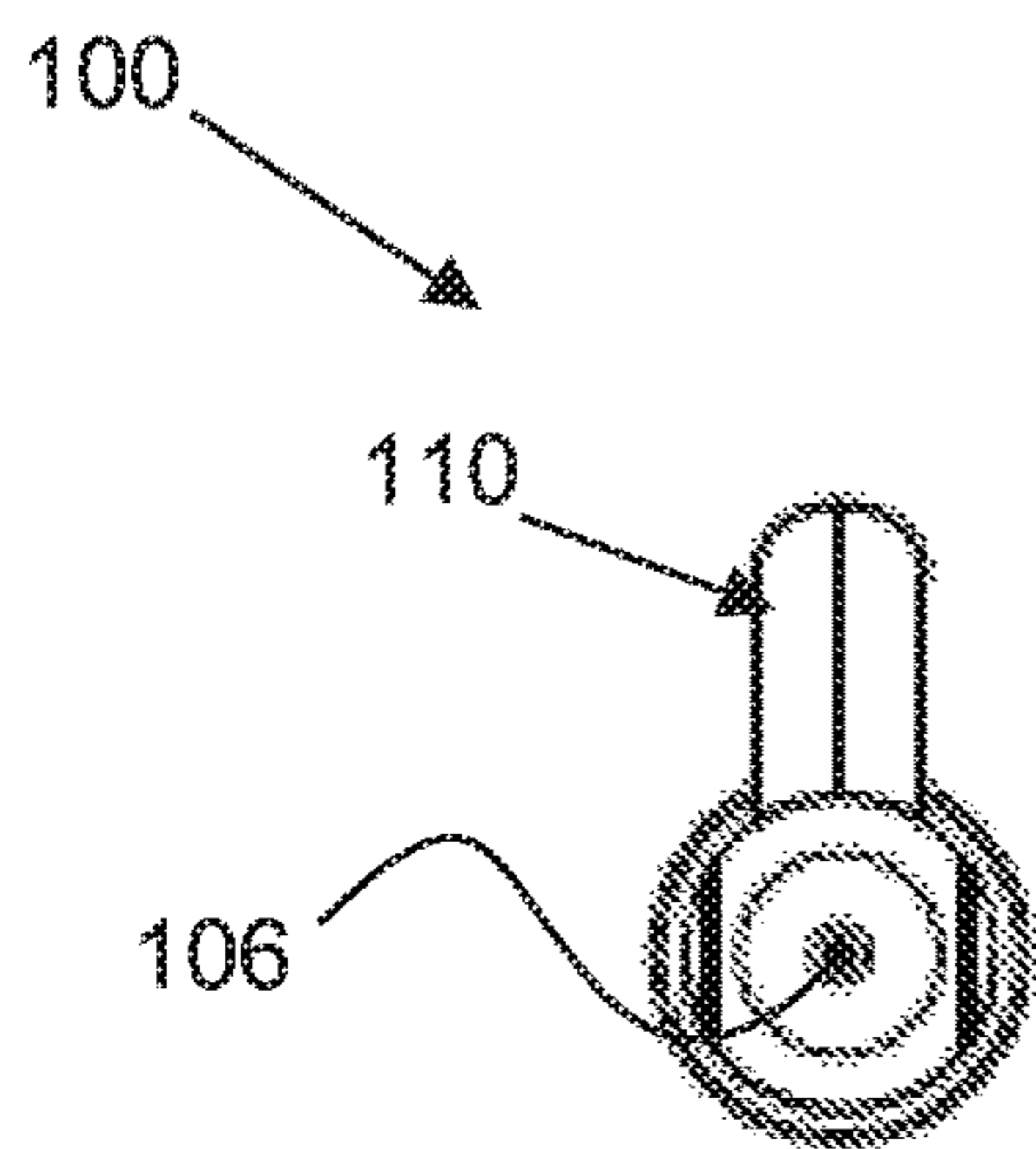

FIG. 8

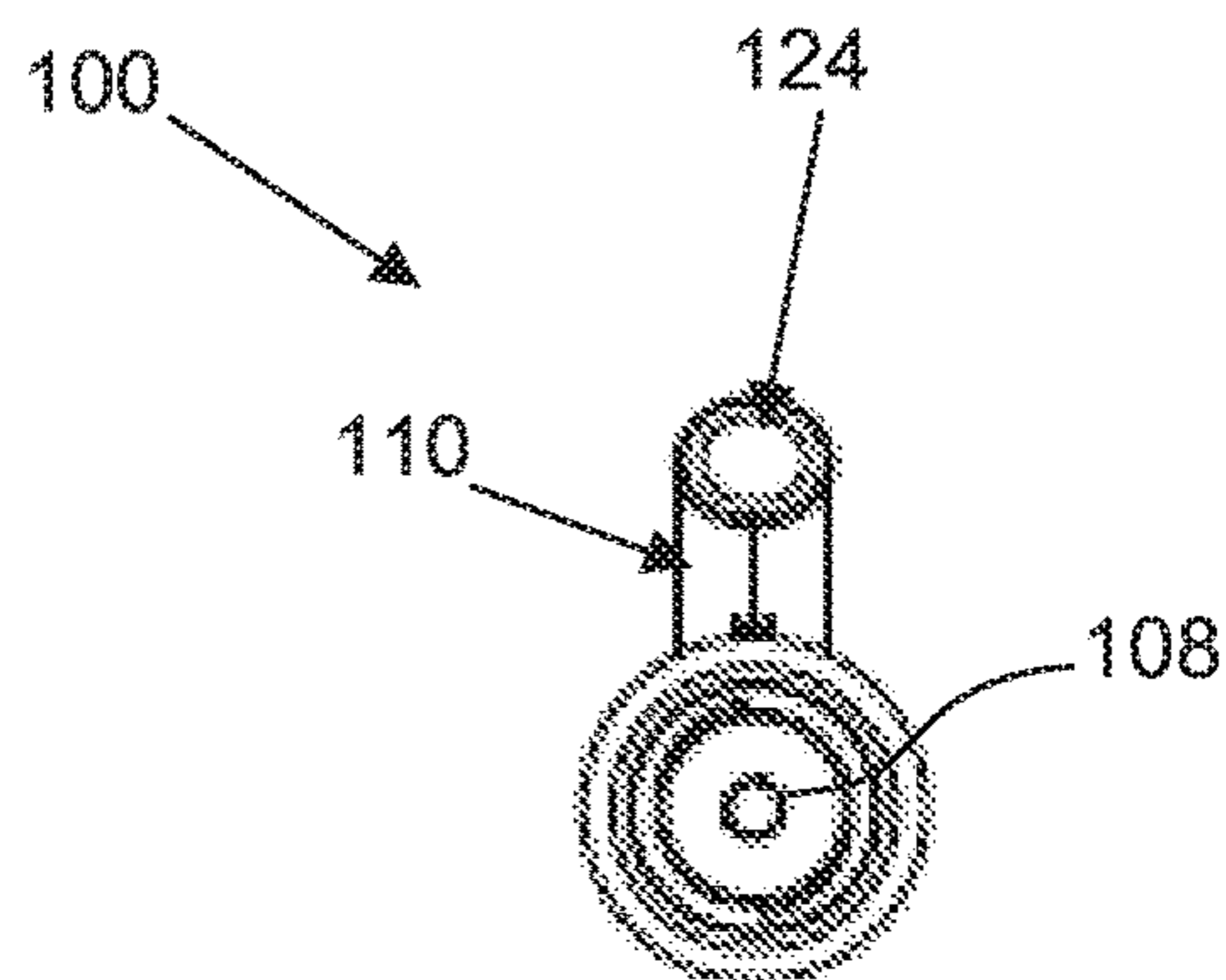

FIG. 9

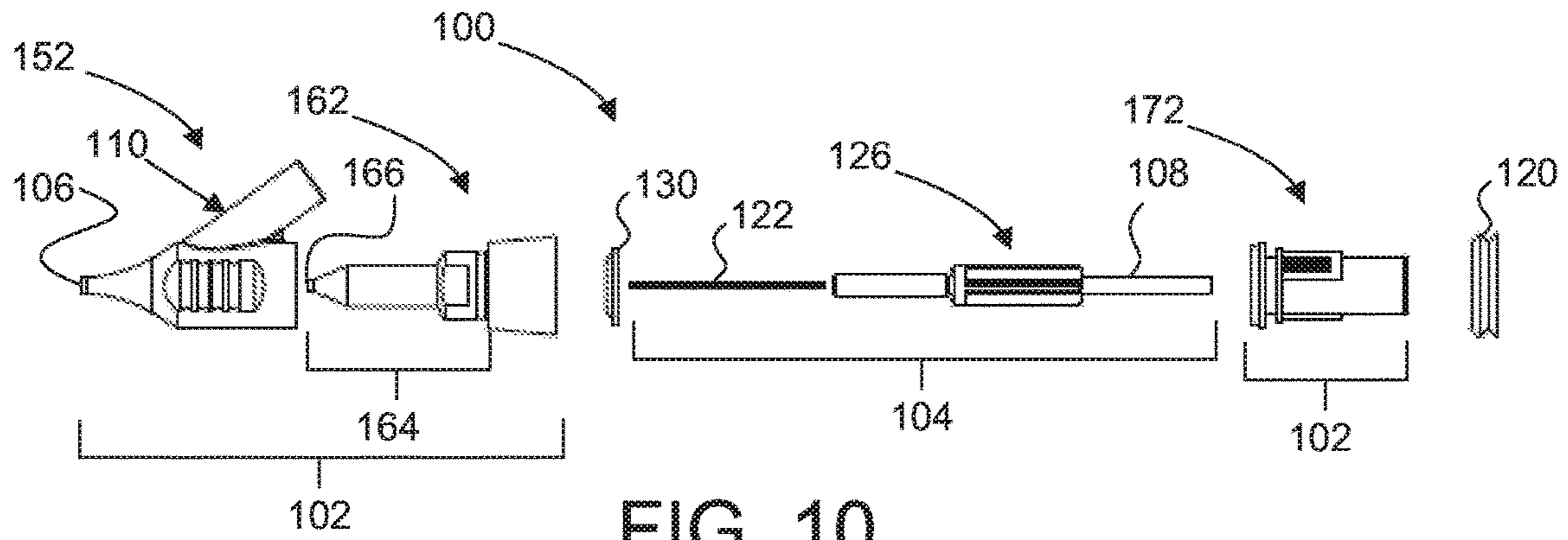

FIG. 10

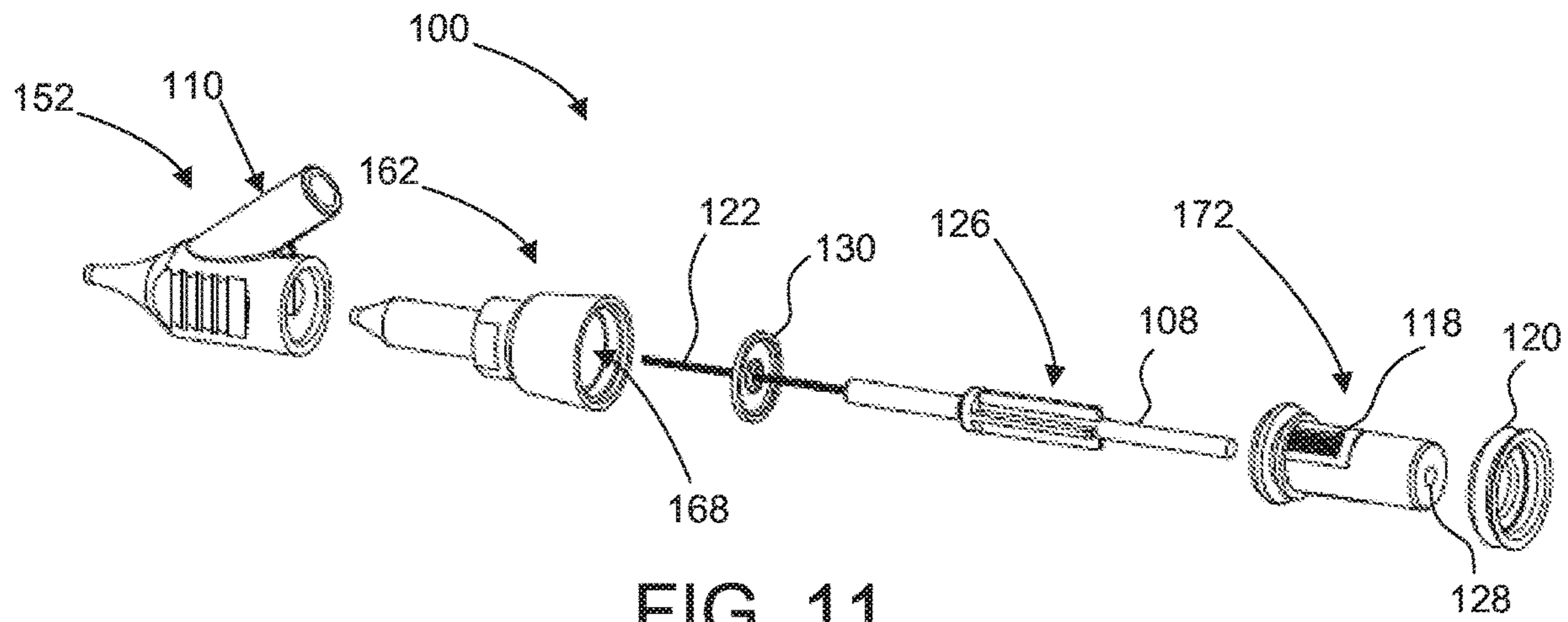

FIG. 11

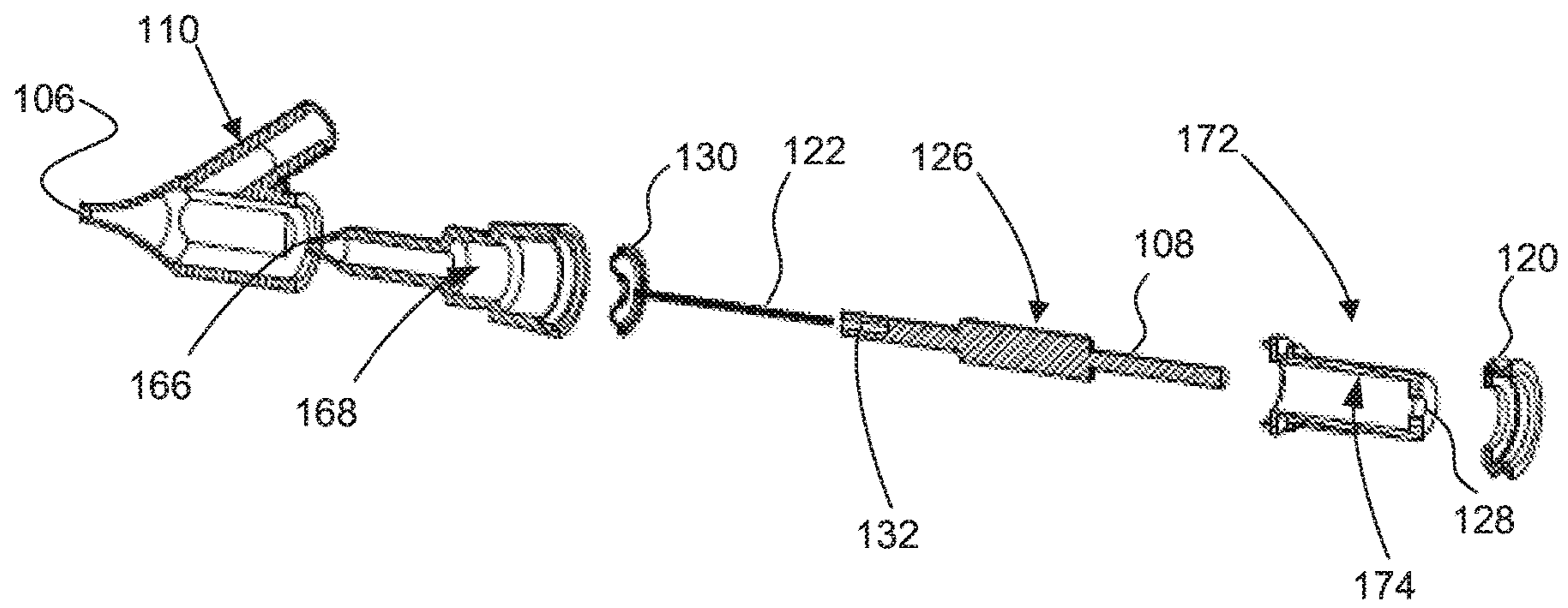

FIG. 12

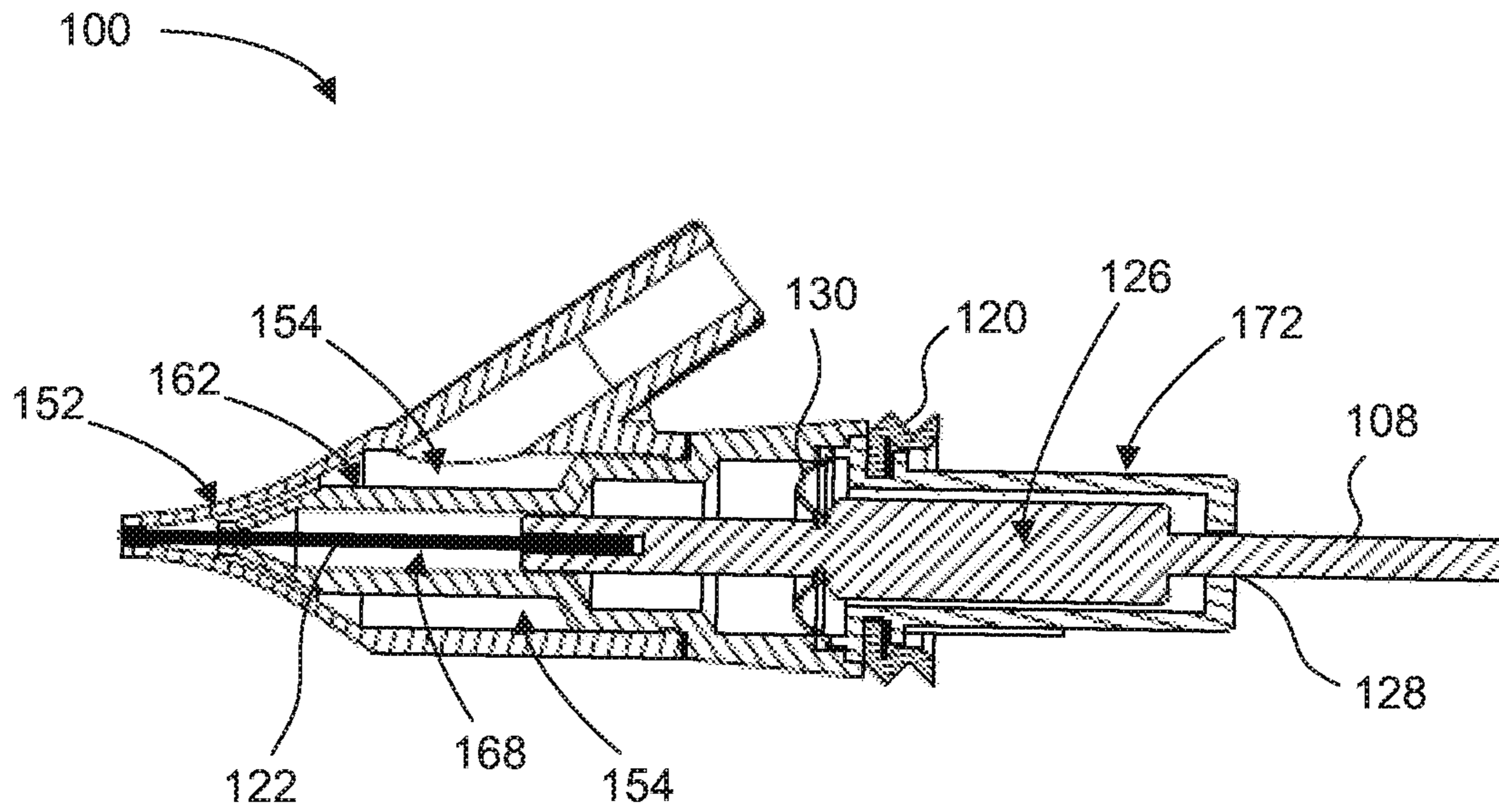

FIG. 13

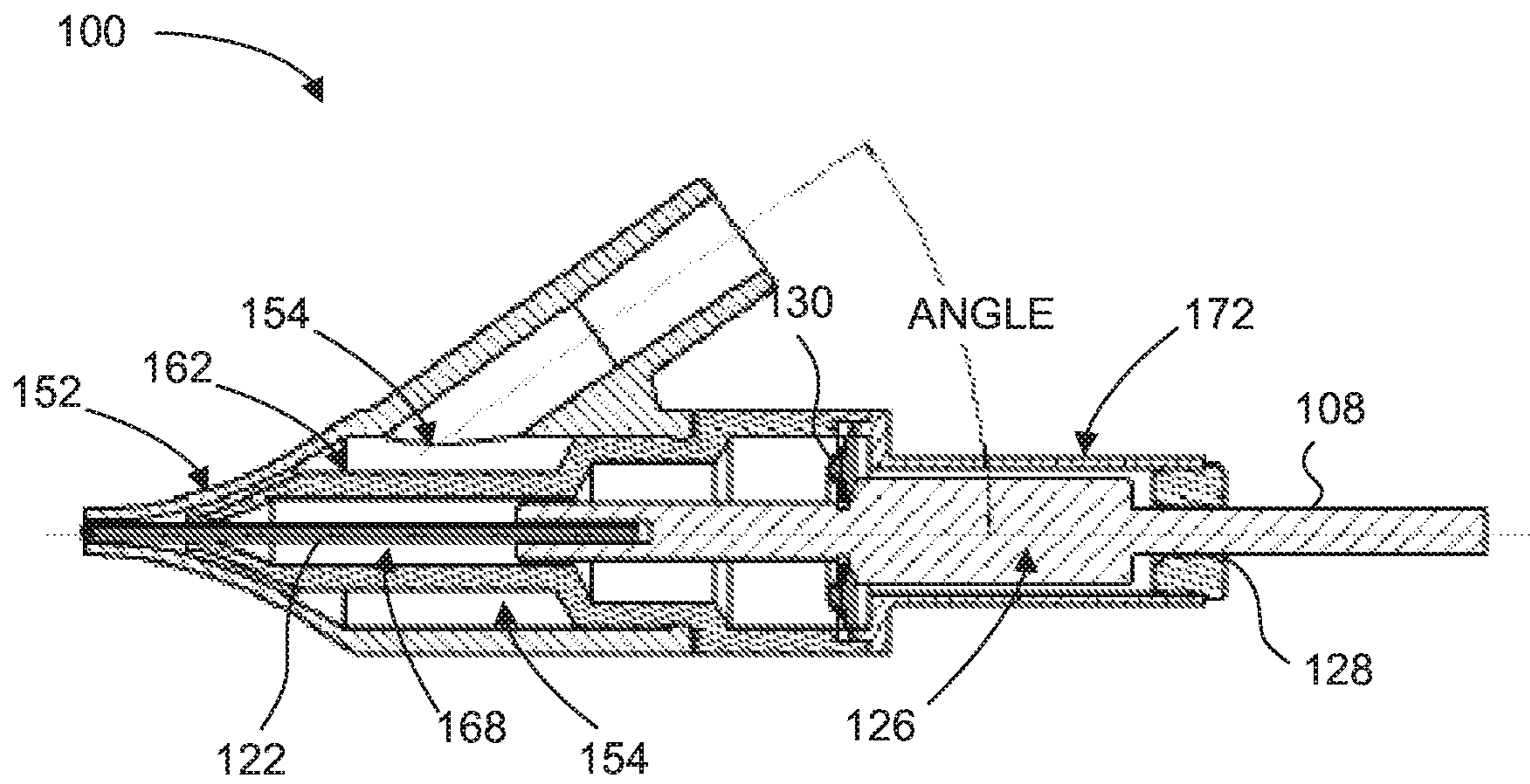

FIG. 14

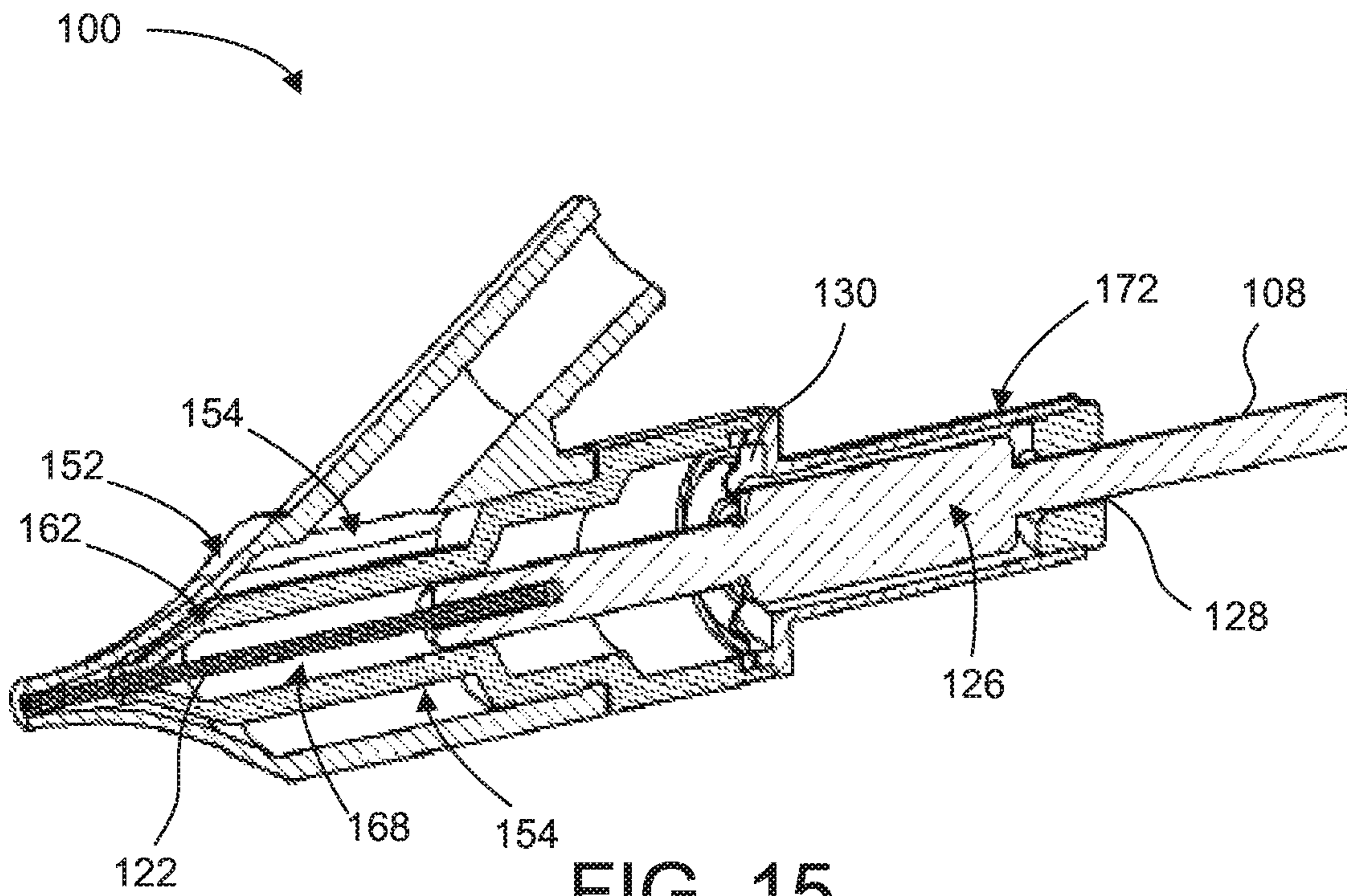

FIG. 15

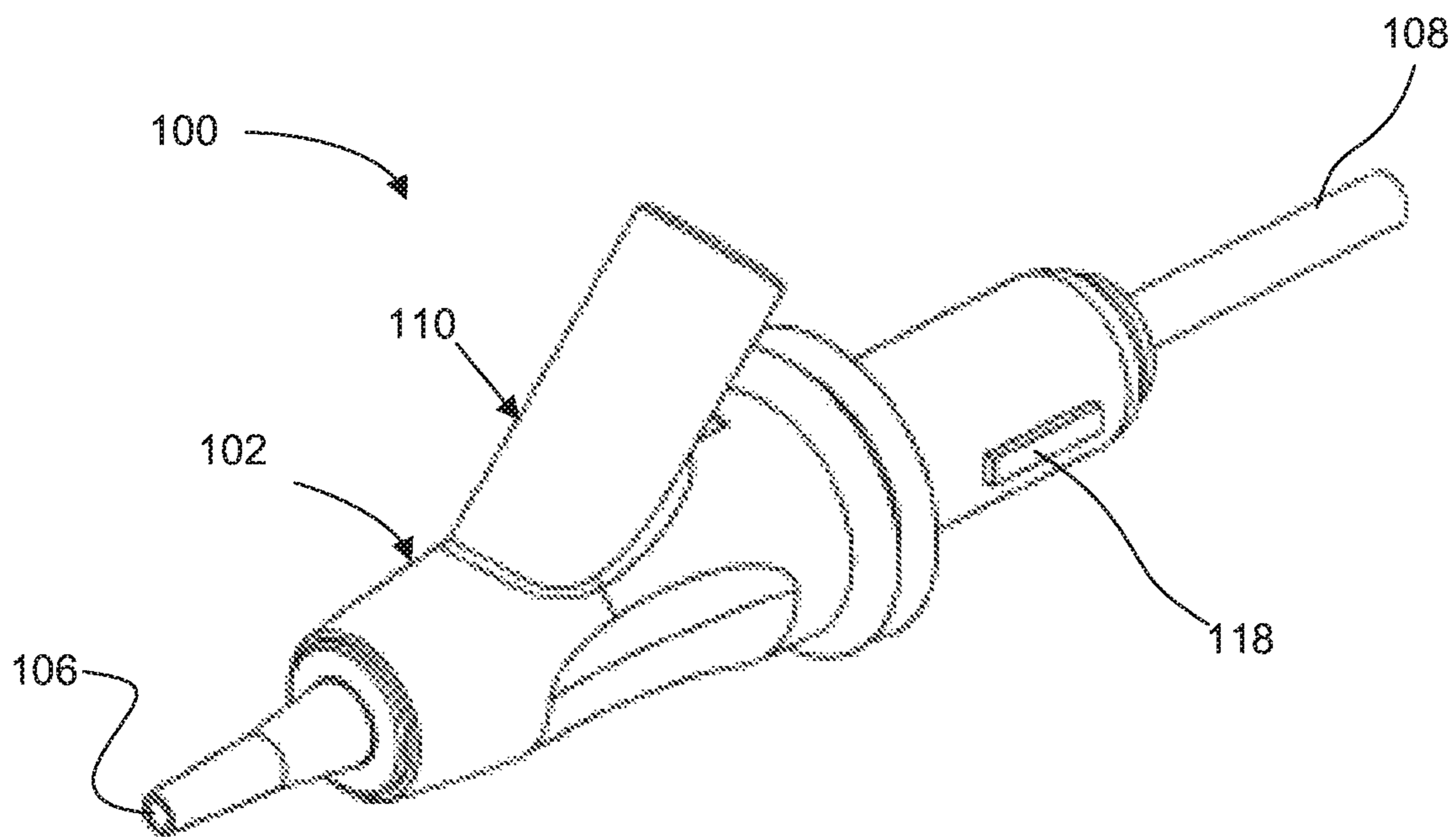

FIG. 16



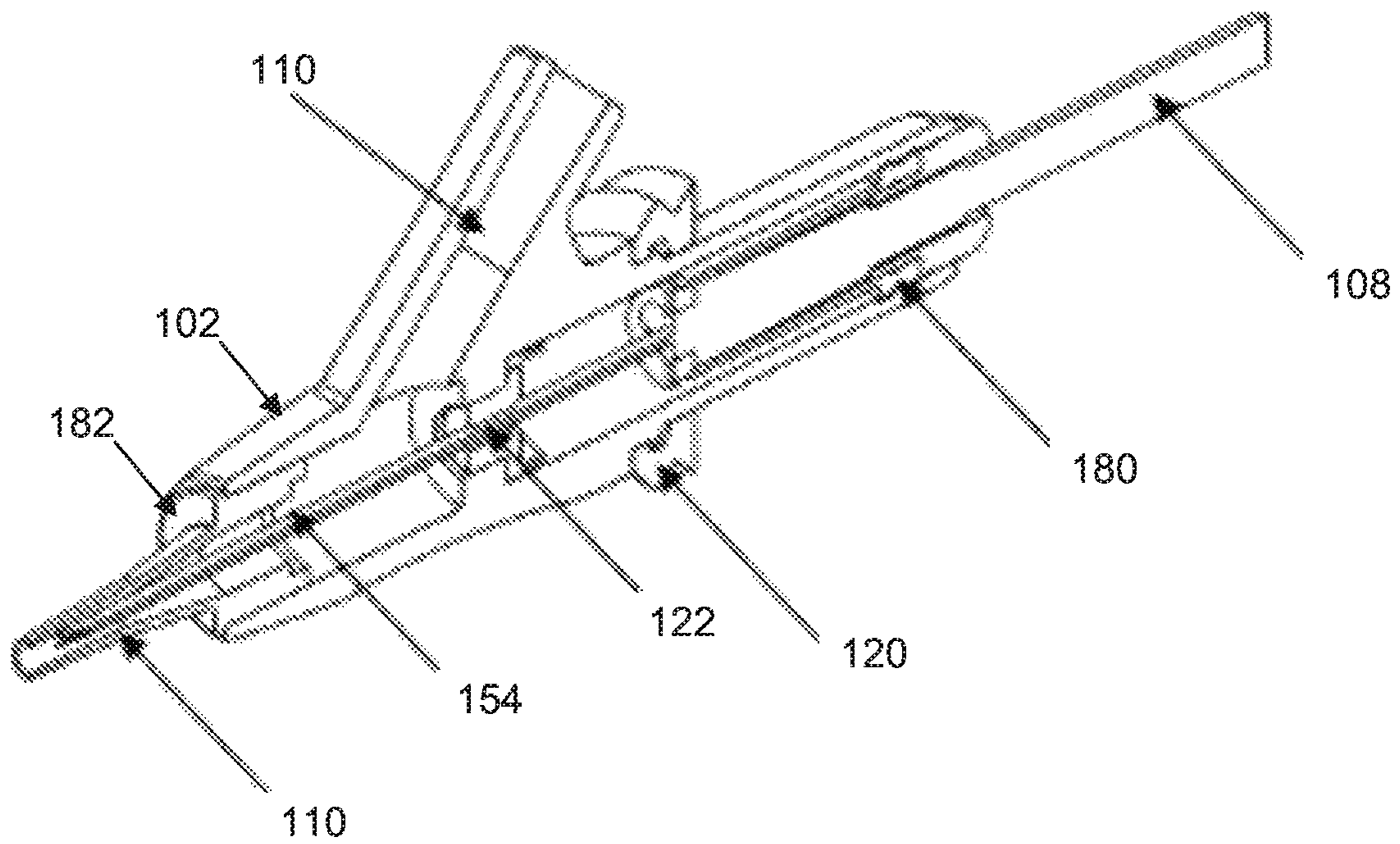

FIG. 17

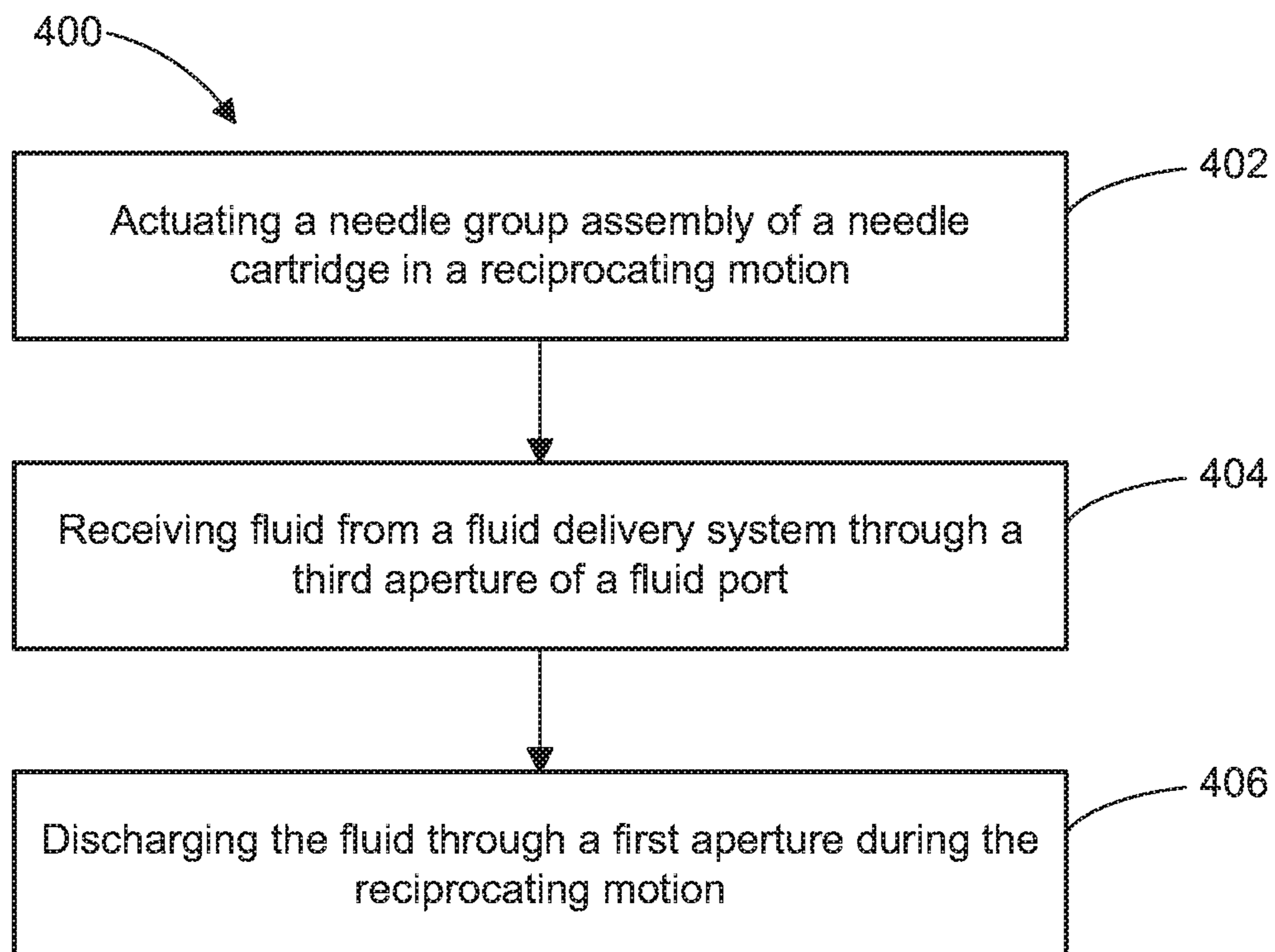

FIG. 18

1

## APPARATUS AND METHOD FOR PUNCTURING THE EPIDERMIS WITH CONTROLLED FLUID DELIVERY

### CROSS-REFERENCE TO RELATED APPLICATIONS

This application is a continuation of U.S. patent application Ser. No. 15/261,660 filed on Sep. 9, 2016, now U.S. Pat. No. 10,610,327, and entitled "Apparatus and Method for Puncturing the Epidermis with Controlled Fluid Delivery," which application claims the benefit of U.S. Provisional Patent Application No. 62/216,206 filed on Sep. 9, 2015 and entitled "Tattoo and Tattoo Removal Device and Method," the contents of each are incorporated by reference herein.

### BACKGROUND

Tattooing is the process of the introduction of colored inks into the dermis layer of skin to permanently color the skin. The process requires the controlled application of the colored inks to the dermis layer of a patient's skin, by repeatedly perforating the epidermis layer of skin with controlled punctures by needles coated in ink. Once punctured, the skin cells wipe the ink from the surface of the needles, which essentially stains these cells with the desired pigments.

Tattoos (as well as permanent make-up) can over time be less desirable for people due to poor design, social stigma, or life changes (e.g., career or relationship changes, etc.). Tattoo removal can be difficult, costly, and painful. Improvements in tattoo removal are needed to better serve a large segment of customers with a less difficult, costly, and painful removal process.

### SUMMARY

The subject matter of the present application has been developed in response to the present state of the art, and in particular, in response to the shortcomings of tattoo removal, that have not yet been fully solved by currently available techniques. Accordingly, the subject matter of the present application has been developed to overcome at least some of the shortcomings of prior art techniques.

Embodiments of an apparatus for puncturing the epidermis with controlled fluid delivery are described. In one embodiment, the apparatus includes a needle cartridge configured to attach to and interface with an actuating device. The needle cartridge includes a housing, a needle group assembly, and a fluid port. The housing forms a cavity and includes a first aperture and a second aperture opposite the first aperture. The needle group assembly includes a needle and a needle holder. The needle group assembly is configured to move in a reciprocating motion relative to the housing along an axis from the first aperture to the second aperture. During the reciprocating motion, the needle fully retracts into the cavity through the first aperture. The fluid port is integrated with the housing and includes a hollow projection forming a conduit and extending away from the housing. The fluid port includes a third aperture, wherein the fluid port is configured to interface with a fluid delivery system. Other embodiments of an apparatus for puncturing the epidermis with controlled fluid delivery are described.

Embodiments of a method for puncturing the epidermis with controlled fluid delivery are described. In one embodiment, the method for puncturing the epidermis with controlled fluid delivery includes actuating a needle group assembly of a needle cartridge in a reciprocating motion,

2

receiving fluid from a fluid delivery system through a third aperture of a fluid port, and discharging the fluid through a first aperture during the reciprocating motion. The needle cartridge includes a housing and the needle group assembly, the housing forming a cavity and including the fluid port, the first aperture, and a second aperture opposite the first aperture. The needle group assembly is housed within the cavity and includes at least one needle and a needle holder. During the reciprocating motion, the at least one needle retracts fully into the cavity through the first aperture. Other embodiments of a method for puncturing the epidermis with controlled fluid delivery are described herein.

Other aspects and advantages of embodiments of the present invention will become apparent from the following detailed description, taken in conjunction with the accompanying drawings illustrated by way of example of the principles of the invention.

The described features, structures, advantages, and/or characteristics of the subject matter of the present disclosure may be combined in any suitable manner in one or more embodiments and/or implementations. In the following description, numerous specific details are provided to impart a thorough understanding of embodiments of the subject matter of the present disclosure. One skilled in the relevant art will recognize that the subject matter of the present disclosure may be practiced without one or more of the specific features, details, components, materials, and/or methods of a particular embodiment or implementation. In other instances, additional features and advantages may be recognized in certain embodiments and/or implementations that may not be present in all embodiments or implementations. Further, in some instances, well-known structures, materials, or operations are not shown or described in detail to avoid obscuring aspects of the subject matter of the present disclosure. The features and advantages of the subject matter of the present disclosure will become more fully apparent from the following description and appended claims, or may be learned by the practice of the subject matter as set forth hereinafter.

### BRIEF DESCRIPTION OF THE DRAWINGS

In order that the advantages of the subject matter may be more readily understood, a more particular description of the subject matter briefly described above will be rendered by reference to specific embodiments that are illustrated in the appended drawings. Understanding that these drawings depict only typical embodiments of the subject matter and are not therefore to be considered to be limiting of its scope, the subject matter will be described and explained with additional specificity and detail through the use of the drawings.

FIG. 1 depicts a perspective view of a needle cartridge for puncturing the epidermis with controlled fluid delivery, according to one or more embodiments of the present disclosure.

FIG. 2 depicts a side view of a needle cartridge and an actuating device, according to one or more embodiments of the present disclosure.

FIG. 3 depicts a side view of a needle cartridge attached to an actuating device, according to one or more embodiments of the present disclosure.

FIG. 4 depicts a cross-sectional side view of a needle cartridge attached to an actuating device, according to one or more embodiments of the present disclosure.

FIG. 5 depicts a top view of a needle cartridge for puncturing the epidermis with controlled fluid delivery, according to one or more embodiments of the present disclosure.

FIG. 6 depicts a side view of a needle cartridge for puncturing the epidermis with controlled fluid delivery, according to one or more embodiments of the present disclosure.

FIG. 7 depicts a bottom view of a needle cartridge for puncturing the epidermis with controlled fluid delivery, according to one or more embodiments of the present disclosure.

FIG. 8 depicts a front view of a needle cartridge for puncturing the epidermis with controlled fluid delivery, according to one or more embodiments of the present disclosure.

FIG. 9 depicts a rear view of a needle cartridge for puncturing the epidermis with controlled fluid delivery, according to one or more embodiments of the present disclosure.

FIG. 10 depicts an exploded side view of a needle cartridge for puncturing the epidermis with controlled fluid delivery, according to one or more embodiments of the present disclosure.

FIG. 11 depicts an exploded perspective view of a needle cartridge for puncturing the epidermis with controlled fluid delivery, according to one or more embodiments of the present disclosure.

FIG. 12 depicts an exploded cross-sectional view of a needle cartridge for puncturing the epidermis with controlled fluid delivery, according to one or more embodiments of the present disclosure.

FIG. 13 depicts a cross-sectional side view of a needle cartridge for puncturing the epidermis with controlled fluid delivery, according to one or more embodiments of the present disclosure.

FIG. 14 depicts a cross-sectional side view of a needle cartridge for puncturing the epidermis with controlled fluid delivery, according to one or more embodiments of the present disclosure.

FIG. 15 depicts a cross-sectional perspective view of a needle cartridge for puncturing the epidermis with controlled fluid delivery, according to one or more embodiments of the present disclosure.

FIG. 16 depicts a perspective view of a needle cartridge for puncturing the epidermis with controlled fluid delivery, according to one or more embodiments of the present disclosure.

FIG. 17 depicts a cross-sectional perspective view of a needle cartridge for puncturing the epidermis with controlled fluid delivery, according to one or more embodiments of the present disclosure.

FIG. 18 depicts a flow chart diagram of a method for puncturing an epidermis with controlled fluid delivery, according to one or more embodiments of the present disclosure.

It will be appreciated that the drawings are illustrative and not limiting of the scope of the invention which is defined by the appended claims. The embodiments shown accomplish various aspects and objects of the invention. It is appreciated that it is not possible to clearly show each element and aspect of the invention in a single figure, and as such, multiple figures are presented to separately illustrate the various details of the invention in greater clarity. Similarly, not every embodiment need accomplish all advantages of the present invention.

While the disclosure is susceptible to various modifications and alternative forms, specific embodiments have been shown by way of example in the drawings and will be described in detail herein. However, it should be understood that the disclosure is not intended to be limited to the particular forms disclosed. Rather, the intention is to cover all modifications, equivalents and alternatives falling within the spirit and scope of the invention as defined by the appended claims.

Throughout the description, similar reference numbers may be used to identify similar elements.

#### DETAILED DESCRIPTION

It will be readily understood that the components of the embodiments as generally described herein and illustrated in the appended figures could be arranged and designed in a wide variety of different configurations. Thus, the following more detailed description of various embodiments, as represented in the figures, is not intended to limit the scope of the present disclosure, but is merely representative of various embodiments. While the various aspects of the embodiments are presented in drawings, the drawings are not necessarily drawn to scale unless specifically indicated.

The present invention may be embodied in other specific forms without departing from its spirit or essential characteristics. The described embodiments are to be considered in all respects only as illustrative and not restrictive. The scope of the invention is, therefore, indicated by the appended claims rather than by this detailed description. All changes which come within the meaning and range of equivalency of the claims are to be embraced within their scope.

Reference throughout this specification to features, advantages, or similar language does not imply that all of the features and advantages that may be realized with the present invention should be or are in any single embodiment of the invention. Rather, language referring to the features and advantages is understood to mean that a specific feature, advantage, or characteristic described in connection with an embodiment is included in at least one embodiment of the present invention. Thus, discussions of the features and advantages, and similar language, throughout this specification may, but do not necessarily, refer to the same embodiment.

Furthermore, the described features, advantages, and characteristics of the invention may be combined in any suitable manner in one or more embodiments. One skilled in the relevant art will recognize, in light of the description herein, that the invention can be practiced without one or more of the specific features or advantages of a particular embodiment. In other instances, additional features and advantages may be recognized in certain embodiments that may not be present in all embodiments of the invention.

Reference throughout this specification to “one embodiment,” “an embodiment,” or similar language means that a particular feature, structure, or characteristic described in connection with the indicated embodiment is included in at least one embodiment of the present invention. Thus, the phrases “in one embodiment,” “in an embodiment,” and similar language throughout this specification may, but do not necessarily, all refer to the same embodiment.

While many embodiments are described herein, at least some of the described embodiments allow for the efficient removal of tattoos, permanent makeup, and other indelible mark or pigment on and under the skin. Some embodiments allow for self-cleaning of a needle grouping. Some embodiments provide for more accurate and consistent depth of

## 5

needle penetration on the skin of a patient. Some embodiments allow for the efficient delivery of fluid with minimal or no leaking of the fluid into the interior of an actuating device. While description herein refers primarily to tattoo removal, the apparatuses, systems, and methods described herein may be also be utilized for tattooing or other application of inks, etc., to the skin of a patient.

Referring to FIG. 1, a perspective view of a needle cartridge **100** for puncturing the epidermis with controlled fluid delivery is shown. In some embodiments, the needle cartridge **100** includes a housing **102** which forms an internal cavity (not visible). The housing **102** at least partially encloses a needle group assembly **104** including a needle group (not visible). In the illustrated embodiment, only a shaft **108** (protruding from the housing **102**) of the needle group assembly is visible.

The needle group assembly **104** is configured to move relative to the housing **102**. In the illustrated embodiment, the needle group assembly **104** reciprocates (relative to the housing **102**) in an axial direction (depicted by arrows **112**) running along the length of the shaft **108**. As the needle group assembly **104** reciprocates relative to the housing **102**, a needle group (not visible) of the needle group assembly reciprocates back and forth at an end opposite the shaft **108**.

The needle group reciprocates back and forth and in and out of the housing **102** through a first aperture **106**. The first aperture **106** is located at a tip of the housing **102** of the needle cartridge **100** on an end opposite where the shaft **108** protrudes from the housing **102**. In the illustrated embodiment, the shaft **108** protrudes out of a second aperture (not visible) of the housing **102**.

Referring to the reciprocating motion of the needle group assembly **104**, an end of the needle group emerges from the housing **102** through the first aperture **106** during a forward motion and retracts back into the housing **102** through the first aperture **106** during a reverse motion. The needle group moves back and forth between a first position (e.g., a retracted position with the needle group wholly within the cavity of the housing **102**) and a second position (e.g., a forward position with an end of the needle group emerged from the first aperture **106**). The needle group is located wholly or at least partially within the cavity of the housing **102** depending on whether the needle group assembly **104** is in a forward position (e.g., an emerged position) or in a backward position (e.g., a retracted position).

In some embodiments, the housing **102** of the needle cartridge includes bearings or bearing surfaces that allow the linear reciprocating motion of the needle group assembly **104** and prevents radial motion in a direction away from a longitudinal axis of the needle group assembly **104**. The bearing surface may be an inside surface of the housing **102**. In some embodiments, the needle cartridge **100** includes bearings within the housing **102** that function to allow the linear reciprocating motion of the needle group assembly **104** and prevent radial motion of the needle group assembly **104**. In addition, the inside surface of the first aperture **106** prevents radial motion of the needle group and the needle group assembly **104**. In some embodiments, the bearings, bearing surfaces, and/or inside surface of the first aperture **106** prevent separation of the needle group in a radial direction.

Although described herein as a needle group, in some embodiments, the needle group assembly **104** includes only a single needle. In some embodiments, the needle group includes a plurality of needles side by side. In some implementations, the needle group includes a grouping of surgically sharpened non-hollow needles. In some embodiments,

## 6

the needles of the needle group are grouped side by side and are formed in a pattern. In some implementations, the needle group forms a circular pattern at the sharpened end of the needles. In some implementations, the needle group forms a linear pattern at the sharpened end of the needles. The needle group may form any of a number of patterns or shapes and may be designed to form a more particular pattern or shape depending on the need of a user.

In some embodiments, the needle group fully retracts into the housing **102** through the first aperture **106** during the reciprocating motion. The full retraction of the needle group during the reciprocating motion facilitates various beneficial functions of the needle cartridge **100**. In one aspect, during tattoo removal (or during application of a tattoo) the depth of penetration of the needle affects the quality of the removal (or application). For example, penetration either too deep into the skin or too shallow may result in subpar removal (or application) of a tattoo. Penetration too deep into the skin may result in unnecessary scarring. Shallow penetration will not allow ink to be removed during the removal process.

In addition, the tattoo removal technician (or tattoo artist) while moving along the skin in a pattern may catch or snag skin if the needle is inserted into the skin while moving the needle transversely across the skin. In embodiments described herein, the tip of the needle cartridge **100** (i.e., the location of the first aperture **106**) may rest on the skin of a patient, allowing the needle group to penetrate the skin at a repeatable depth. In addition, while the needle group is in a fully retracted position, the needle cartridge can be moved transversely to the surface of the skin without catching or snagging the skin. This allows for a far more repeatable process and less training of technicians, as the technician can rest the tip of the needle cartridge on the skin of a patient. In addition, during the tattoo removal process, the reciprocating needle group punctures and break ups the superficial dermal layer of skin to uncover the ink. The tip of the needle cartridge can push the dermal debris aside.

In some embodiments, the needle cartridge **100** is configured to interface with a fluid delivery system. The fluid delivery system may include a fluid reservoir, a pumping system, and a fluid dispenser which is configured to attach to the needle cartridge **100** and deliver fluid into the needle cartridge **100**. In some embodiments, the fluid delivery system interfaces with a fluid port **110**.

In the illustrated embodiment, the needle cartridge **100** includes a fluid port **110** integrated with the housing **102**. In some embodiments, the fluid port **110** is integral with the housing. In some embodiments, the fluid port **110** attaches to the housing **102** and forms a seal between the housing **102** and the fluid port **110**. In some embodiments, the needle cartridge **100** is configured to receive fluid into the cavity through the fluid port and discharge fluid from the cavity through the first aperture **106**.

The fluid port **110** is a projection that extends away from the housing **102** at an angle. The projecting fluid port **110** extends away from a longitudinal axis of the housing **102** (i.e., an axis running from the first aperture **106** to the second aperture of the housing **102**). The vertex of the angle formed between the projecting fluid port **110** and the longitudinal axis is oriented toward the end of the housing **102** comprising the first aperture **106**. That is the opening of the fluid port **110** or third aperture **124** is oriented towards the rear of the needle cartridge **100**. In addition, the rear facing fluid port **110** also guides the connecting tube to the rear of the actuating device and away from the tip of the needle cartridge so as to not obstruct the view of the tip or interfere with the puncturing process.

In the illustrated embodiment, the fluid port **110** is a hollow projection extending from the housing **102** and forming a channel or conduit to the internal cavity of the housing **102**. In some embodiments, the fluid port is a hollow cylindrical projection extending from the housing **102**. The channel or conduit may be any of a number of shapes including a circular cylinder, an elliptical cylinder, a curvilinear cylinder, a polyhedral prism, a combination of a curvilinear cylinder and a polyhedral prism. In some embodiments, the fluid port **110** forms a Luer taper. The taper is designed to allow the insertion of mating connectors (such as a tubing set) and to allow them to be attached with minimal forces while allowing the connection to seal to pressures ranging from 5 psi to 10 psi. The taper further allows the disconnection of the mating connectors with minimal force with no damage or distortion to the taper and mating connectors and further allows, if required, the insertion and sealing of other connectors. For example, a tubing set introduced into the fluid port **110** may form a water tight fitting known as a Luer taper. The angles within the conduit cause the tubing set to be retained in a semi-permanent joint.

The easy connection of the needle cartridge **100** to the fluid delivery system allows the needle cartridge **100** to be easily replaced and allows an operator use a new needle cartridge **100** for each new application.

The fluid port **110** includes a third aperture through which a fluid can be introduced to the internal cavity of the housing **102** and which ultimately exits from the first aperture **106**. In some embodiments, the fluid port **110** includes fluid flow control features. Flow control features may allow fluid to enter the housing **102** through the fluid port **110** but may also restrict fluid flow from exiting the housing **102** at the fluid port **110**. In some embodiments, the fluid port **110** includes a check valve oriented to allow fluid to enter the housing **102** and to prevent fluid outflow. Some embodiments may include a flexible elastomeric silicone or rubber diaphragms, flappers, or a duckbill construction, or other known check valves. The valve may be sized to fit the conduit of the fluid port **110**. In some embodiments, the flow control features may be a high cracking pressure valve to prevent back flow when the needle cartridge **100** is used with a pressurized fluid flow from a pump.

In some embodiments, the needle cartridge **100** further includes an internal seal (for example, elastomeric) to form a seal between the first aperture **106** and the second aperture. The internal seal restricts fluid flow from exiting the housing at the second aperture. The internal seal forms a seal between the inside surface of the housing and the outer surface of the needle group assembly **104**. In some embodiments, the internal seal is attached to the inside surface of the housing **102** and is further attached to the needle group assembly **104**. In some embodiments, the needle group assembly **104** includes a smaller diameter landing area or recessed area onto which the internal seal is attached. The recessed area functions to prevent movement of the internal seal along the length of the needle group assembly **104** during the reciprocating motion of the needle group assembly **104**. The internal seal may act as a spring member to bias the needle group assembly **104** in a particular direction. The internal seal may bias the needle group assembly **104** back to an original position after being displaced or driven by an actuating device. In some embodiments, the internal seal, when used in conjunction with a check valve (i.e., in the fluid port **110**), can operate as a displacement pump allowing gravity fed fluids fed into the housing **102** to be displaced out the first aperture **106** of the housing **102**.

In some embodiments, the needle cartridge **100** is configured to attach to and interface with an actuating device (see e.g., FIGS. 2-4). The actuating device is a mechanical device that physically actuates the needle group assembly **104** and causes the reciprocating motion of the needle group assembly **104** relative to the housing. In some embodiments, the needle cartridge **100** is configured to attach to the actuating device such that the housing **102** does not move relative to the actuating device. The actuating device may have a push rod or other feature which interfaces and moves the needle group assembly **104** in a reciprocating motion. In some embodiments, the housing **102** includes an interface configured to lock the housing **102** into the actuating device. In some embodiments, the needle cartridge **100** is configured to attach at an end opposite the first aperture **106**. The housing **102** may include features which interface with the actuating devices (such as clips, notches, seals, etc.).

Although the needle cartridge **100** is shown and described with certain components and functionality, other embodiments of the needle cartridge **100** may include fewer or more components to implement less or more functionality. In addition, each of the components and functionality described in conjunction with FIG. 1 may be applied to each of the remaining figures of the application although not necessarily described herein.

Referring to FIG. 2, a side view of a needle cartridge **100** and an actuating device **200** is shown. The actuating device **200** is a handheld device similar to the actuating device described in conjunction with FIG. 1 and is configured to hold the needle cartridge **100**. In addition, the actuating device **200** is configured to actuate a needle group assembly **104** in a reciprocating motion. The needle cartridge **100** is inserted into the actuating device **200** (shown in an attached configuration in FIGS. 3 and 4). In the illustrated embodiment, the needle cartridge **100** includes a tapered end **114** including a first aperture **106** through which a needle or needle group may come forth from an internal cavity (not visible). In some embodiments, the needle cartridge **100** is configured to attach to and interface with the actuating device **200** (see e.g., FIGS. 3-4) at a second end **116** opposite the tapered end **114**. The needle cartridge **100** is further configured to interface with a fluid delivery system **300** (see e.g., FIG. 3) at a fluid port **110**. The needle cartridge **100** and/or the housing **102** may include various features **118** which interface and interact with the actuating device **200** to connect and attach the needle cartridge **100** to the actuating device **200**.

The illustrated embodiment includes an outer seal **120** that circumferentially surrounds an outer surface of the second end **116** and is configured to interface with an opening of the actuating device **200**. The outer seal **120** seals the needle cartridge **100** to the actuating device **200** restricting the ingress of fluid into the interior of the actuating device **200** through the opening. The actuating device **200** interfaces with the protruding shaft **108** of the needle group assembly **104** and actuates the needle group assembly in a reciprocating motion relative to housing of the needle cartridge **100**.

Referring to FIG. 3, a needle cartridge **100** is shown attached to an actuating device **200** and a fluid delivery system **300**. The fluid delivery system **300** may include a fluid reservoir (not shown), a pumping system (not shown), and a dispenser **302** which is configured to attach to the needle cartridge **100** at the fluid port **110** and deliver fluid into the needle cartridge **100**. FIG. 3 depicts the needle cartridge **100** inserted into an opening of the actuating

device **200** with the outer seal **120** forming a seal between the housing **102** and the opening of the actuating device **200**.

In the illustrated embodiment, a needle group **122** is shown protruding from the housing **102** through the first aperture **106**. As described above, a needle group assembly **104** is actuated by the actuating device **200** and caused to move in a reciprocating motion. An end of the needle group emerges from the housing **102** through the first aperture **106** during a forward motion and retracts back into the housing **102** through the first aperture **106** during a reverse motion. The needle group moves back and forth between a first position (e.g., a retracted position with the needle group wholly within the cavity of the housing **102**) and a second position (e.g., a forward position with an end of the needle group emerged from the first aperture **106**). FIG. **3** depicts the needle group in the second position (emerged from the first aperture **106**).

The fluid delivery system **300** delivers fluid from the dispenser **302** into a third aperture of the housing **102** in the fluid port **110** and out the first aperture **106**. As the needle group **122** retracts fully into the housing **102**, the first aperture **106** cleans the needle group **122**. That is, the interior surface of the first aperture **106** wipes the exterior surface of the needle group **122** during the reverse motion. The fluid delivered by the cartridge may vary depending on the particular function, each having varying properties (e.g., viscosity, etc.) and compositions. In some applications, for example an application using a highly viscous fluid or a fluid that agglomerates, a blockage may form over the first aperture **106**. The self-cleaning of the needle group **122** that occurs upon retraction of the needle group **122** into the housing keeps the fluid from agglomerating and blocking fluid flow through the first aperture **106**. In addition, dermal debris can sometimes lodge or get stuck in the needle group **122** and/or the first aperture **106**. The self-cleaning of the needle group **122** that occurs upon full retraction of the needle group into the housing dislodges the dermal debris.

In addition to the self cleaning of the needle group **122**, clogging of the aperture is ameliorated by fluid pressure from the fluid delivery system **300**. As described more fully herein, the needle cartridge is sealed with the fluid entering at the third aperture and exiting at the first aperture. The positive pressure applied from the fluid delivery system pushes any clogs from the first aperture. This is possible because the fluid port **110** is sealed to and/or integral with the cartridge housing. In addition, the Luer taper and seal formed therein at the fluid port **110** also allows for the pressure to build and only allow fluid to exit at the first aperture. The sealed housing allows for the pressure to build and only allow the fluid to exit at the first aperture.

FIG. **4** shows a cross-sectional side view of a needle cartridge **100** attached to an actuating device **200**. As shown the second end **116** of the needle cartridge **100** is inserted into and interfaces with the actuating device **200**. In the illustrated embodiment, the actuating device **200** includes a push rod **202**. The push rod **202** of the actuating device **200** interfaces with the protruding shaft **108** of the needle cartridge **100** and actuates the needle group assembly **104** causing a needle or needle group **122** to reciprocate back and forth and in and out the first aperture **106** of the needle cartridge **100**. The fluid delivery system **300** dispenses a fluid into the fluid port **110** through a third aperture **124** of the housing **102** while the actuating device **200** actuates the needle group **122**. The needle cartridge **100** further includes an outer seal **120** that circumferentially surrounds an outer surface of the second end **116** and is configured to interface with the opening of the actuating device **200**. The outer seal

**120** seals the needle cartridge **100** to the actuating device **200** restricting the ingress of fluid into the interior of the actuating device **200**, thereby protecting the push rod **202** and other internal components of the actuating device **200**.

The fluid enters into the needle cartridge **100** at the third aperture **124** and exits the needle cartridge **100** at the first aperture **106**. The fluid exits the first aperture **106** and contacts the skin of the patient while the needle group **122** is reciprocating and penetrating the skin of the patient. The fluid is delivered to the skin to aid in the removal of ink of a tattoo. In the illustrated embodiment, the needle group assembly **104** includes a needle group **122** and a needle holder **126**. The needle holder **126** includes the shaft **108** which protrudes out of the housing **102** through the second aperture **128**. The needle holder **126** includes a recessed space on an opposite end to the shaft **108** and holds the needle group **122** together in the recessed space. The needle group **122** may be secured to the needle holder, in some embodiments, by adhesive, insert molding, or other means of attachment. In some embodiments, the plurality of needles in the needle group **122** are welded, brazed, or soldered together. In such embodiments, the needle group **122** is then attached or secured to the needle holder **126**.

Referring to FIGS. **5-9**, various views of a needle cartridge **100** are shown, according to one or more embodiments of the present disclosure. FIG. **5** shows a top view of the needle cartridge **100** for puncturing the epidermis with controlled fluid delivery. FIG. **6** depicts a side view of a needle cartridge for puncturing the epidermis with controlled fluid delivery. FIG. **7** depicts a bottom view of a needle cartridge for puncturing the epidermis with controlled fluid delivery. FIG. **8** depicts a front view of a needle cartridge for puncturing the epidermis with controlled fluid delivery. FIG. **9** depicts a rear view of a needle cartridge for puncturing the epidermis with controlled fluid delivery.

Referring to FIGS. **10-12**, exploded views of a needle cartridge **100** are shown, according to one or more embodiments of the present disclosure. FIG. **10** depicts an exploded side view of a needle cartridge **100** for puncturing the epidermis with controlled fluid delivery. FIG. **11** depicts an exploded perspective view of a needle cartridge. FIG. **12** depicts an exploded cross-sectional view of a needle cartridge. The needle cartridge **100** includes a housing **102** and a needle group assembly **104**. In the illustrated embodiment, the housing **102** is formed from separate components including an outer housing **152**, a needle group housing **162**, and a needle holder housing **172**. The outer housing **152**, the needle group housing **162**, and the needle holder housing **172** connect together to form the housing **102** and in some embodiments, include some or all the features described in conjunction with the preceding figures. In other embodiments, the housing **102** is a single integral piece (see e.g., FIG. **17** and associated description).

In the illustrated embodiment, the outer housing **152** includes the first aperture **106** through which the needle group **122** of the needle group assembly reciprocates and exits the housing **102**. The inner surface of the first aperture **106** is sized to correspond to the outer surface of the needle group **122**. In some embodiments, the inner surface of the first aperture **106** is slightly larger than the outer surface of the needle group **122**. In such embodiments, the inner surface of the first aperture **106** wipes the outer surface of the needle group **122** during the retraction of the needle group **122** into the housing **102** through the first aperture **106**.

The outer housing **152** forms a cavity into which a portion **164** of the needle group housing **162** fits. The inside surface

## 11

of the outer housing 152 and the outside surface of the needle group housing 162 forms a fluid cavity (depicted more clearly in FIGS. 13 and 14). The outer housing 152 further includes the fluid port 110. The fluid port 110 may include some or all the features and components described in conjunction with the remaining figures in this specification. The fluid from the fluid delivery system enters the fluid cavity at the third aperture 124 of the fluid port 110 and exits the fluid cavity at the first aperture 106.

The needle group housing 162 forms a needle group cavity 168 in which is housed a portion of the needle group 122. The needle group housing separates the fluid cavity from the needle group cavity 168. The needle group housing 162 further includes a fourth aperture 166 through which the needle group 122 reciprocates. In some embodiments, the needle group 122 not only reciprocates back and forth and in and out the first aperture 106 (similar to what is described above) but also reciprocates back and forth and in and out the fourth aperture 166. In such embodiments, the inside surface of the fourth aperture 166 may function in a manner similar to the first aperture 106 by wiping or scraping fluid off the needle group 122 during the retraction of the needle group. In other embodiments, the needle group 122 is always protruding from the fourth aperture 166 during the reciprocating motion.

In some embodiments, the needle group housing 162 is configured to attach to the outer housing 152 and may snap into the outer housing 152. In some embodiments, the needle group housing 162 and/or outer housing 152 may include various recesses and/or protrusions to allow their attachment together. Some embodiments may further include seals to restrict fluid flow to the above described fluid paths (i.e. into the fluid port 110 and out the first aperture 106).

The needle holder housing 172 forms a cavity in which is housed at least a portion of the needle holder 126. The needle holder housing 172 includes a bearing surface 174 that allows the linear reciprocating motion of the needle group assembly 104 and prevents radial motion. The bearing surface 174 is an inside surface of the needle holder housing 172. The needle holder housing 172 further includes the second aperture 128. The needle holder housing 172 is configured to attach to the needle group housing 162. In some embodiments, the needle group housing 162 and/or needle holder housing 172 may include various recesses and/or protrusions to allow their attachment together. Some embodiments may further include seals to restrict fluid flow from entering the cavity within the needle holder housing 172.

Referring to FIG. 12, a cross-sectional view of the needle holder 126 is shown. In some embodiments, the needle holder 126 includes a recessed space 132 on an opposite end of the needle holder 126 from the shaft 108. The recessed space 132 holds the needle group 122 together in the recessed space. The needle group 122 may be secured to the needle holder, in some embodiments, by adhesive, insert molding, or other means of attachment.

Referring to FIG. 13, the needle cartridge 100 is depicted with the housing formed with the housing 102 formed. The housing 102 is formed from the outer housing 152, the needle group housing 162, and the needle holder housing 172. Also depicted in FIG. 13 is the fluid cavity 154 which is a chamber bounded by the inner surface of the outer housing 152 and the outer surface of the needle group housing 162. Also depicted FIG. 13 is the needle group assembly 104 including the needle group 122 affixed into the recessed space 132 of the needle holder 126. The shaft 108 of the needle holder is shown protruding through the second

## 12

aperture 128. Also depicted are the outer seal 120 and the internal seal 130. The internal seal 130 is shown seated in a smaller diameter recess on the needle holder 126 and further forming a seal between the first aperture 106 and the second aperture 128.

In some embodiments, the needle group housing 162 includes a bearing surface that allows the linear reciprocating motion of the needle group assembly 104 and prevents radial motion. The bearing surface is an inside surface of the needle group housing 162 and is depicted in FIG. 13 with the needle holder abutting the bearing surface of the needle group housing 162.

FIG. 14 depicts a cross-sectional side view of another embodiment of a needle cartridge 100 for puncturing the epidermis with controlled fluid delivery. FIG. 15 depicts a cross-sectional perspective view of the needle cartridge 100. The features, components, and functionality of FIGS. 14-15 are not described in detail for the sake of brevity, but the needle cartridge 100 of FIGS. 14-15 may include some or all of the features, components, and functionality described in conjunction with FIGS. 1-13. FIG. 14 depicts the angle between the fluid port 110 and the longitudinal axis of the housing 102 (i.e., the axis running from the first aperture 106 to the second aperture 128). The vertex of the angle formed between the projecting fluid port 110 and the longitudinal axis is oriented toward the end of the housing 102 comprising the first aperture 106. That is the opening of the fluid port 110 or third aperture 124 is oriented towards the rear of the needle cartridge 100.

FIG. 16 depicts a perspective view of another embodiment of a needle cartridge 100. FIG. 17 depicts a cross-sectional perspective view of the needle cartridge 100. The features, components, and functionality of FIGS. 16-17 are not described in detail for the sake of brevity, but the needle cartridge 100 of FIGS. 16-17 may include some or all of the features, components, and functionality described in conjunction with FIGS. 1-15. Referring now to the FIG. 17, the housing 102 is a single piece that forms the fluid cavity 154 and includes the fluid port 110. In addition, FIG. 17 depicts a bearing 180 that allows the linear reciprocating motion of the needle group assembly 104 and prevents radial motion. In addition, the needle cartridge includes a nozzle 182 affixed into the housing 102 which, in some embodiments, forms the first aperture 106. In addition, the nozzle 182 can be replaced or changed in the housing 102 to accommodate different size and shapes for the first aperture 106, where the size and shape of the first aperture 106 corresponds to the shape and pattern of the needle group 122. For example, if a square needle group 122 is utilized the nozzle 182 can be swapped for a nozzle 182 with a square aperture 106. Multiple nozzles 182 can be used with the same housing 102. In addition, the shape of the inside surface of the first aperture 106, in some embodiments, may prevent rotational motion of the needle group 122 and/or needle group assembly 104. Preventing rotational motion of the needle group 104 may be important in non-circular needle groups as rotation of the needle group 104 will result in a different pattern on the skin during needle penetration.

FIG. 18 depicts a flow chart diagram of an embodiment of a method 400 for puncturing an epidermis with controlled fluid delivery. Although the method 400 for puncturing an epidermis with controlled fluid delivery is described in conjunction with the needle cartridge 100, the actuating device 200, and the fluid delivery system 300 of FIGS. 1-17, embodiments of the method 400 may be implemented with other types of apparatuses and systems.



At 402, a needle group assembly of a needle cartridge is actuated in a reciprocating motion. In some embodiments, the needle cartridge includes a housing and the needle group assembly, the housing forming a cavity and including the fluid port, the first aperture, and a second aperture opposite the first aperture. In some embodiments, the needle group assembly is housed within the cavity and includes at least one needle and a needle holder. During the reciprocating motion, the at least one needle retracts fully into the cavity through the first aperture. At 404, fluid from a fluid delivery system is received through the third aperture of a fluid port. At 406, the fluid is discharged through a first aperture during the reciprocating motion. The depicted method 400 then ends. Embodiments of the method 400 may further include some or all of the features, components, and functionality described above in conjunction with FIGS. 1-17 and are not described herein for the sake of brevity.

In the above description, certain terms may be used such as “up,” “down, H H upwards,” “downwards, H H upper,” “lower,” “horizontal,” “vertical,” “left,” “right, H ‘3 over, 5, ‘3 under” and the like. These terms are used, where applicable, to provide some clarity of description when dealing with relative relationships. But, these terms are not intended to imply absolute relationships, positions, and/or orientations. For example, with respect to an object, an “upper” surface can become a “lower” surface simply by turning the object over. Nevertheless, it is still the same object. Further, the terms “including, 5, ‘3 comprising,” “having,” and variations thereof mean “including but not limited to” unless expressly specified otherwise. An enumerated listing of items does not imply that any or all of the items are mutually exclusive and/or mutually inclusive, unless expressly specified otherwise. The terms “a,” “an,” and “the” also refer to “one or more” unless expressly specified otherwise. Further, the term “plurality” can be defined as “at least two.”

Additionally, instances in this specification where one element is “coupled” to another element can include direct and indirect coupling. Direct coupling can be defined as one element coupled to and in some contact with another element. Indirect coupling can be defined as coupling between two elements not in direct contact with each other, but having one or more additional elements between the coupled elements. Further, as used herein, securing one element to another element can include direct securing and indirect securing. Additionally, as used herein, “adjacent” does not necessarily denote contact. For example, one element can be adjacent another element without being in contact with that element.

As used herein, the phrase “at least one of”, when used with a list of items, means different combinations of one or more of the listed items may be used and only one of the items in the list may be needed. The item may be a particular object, thing, or category. In other words, “at least one of” means any combination of items or number of items may be used from the list, but not all of the items in the list may be required. For example, “at least one of item A, item B, and item C” may mean item A; item A and item B; item B; item A, item B, and item C; or item B and item C. In some cases, “at least one of item A, item B, and item C” may mean, for example, without limitation, two of item A, one of item B, and ten of item C; four of item B and seven of item C; or some other suitable combination.

Unless otherwise indicated, the terms “first,” “second,” etc. are used herein merely as labels, and are not intended to impose ordinal, positional, or hierarchical requirements on the items to which these terms refer. Moreover, reference to, e.g., a “second” item does not require or preclude the

existence of, e.g., a “first” or lower-numbered item, and/or, e.g., a “third” or higher-numbered item.

As used herein, a system, apparatus, structure, article, element, component, or hardware “configured to” perform a specified function is indeed capable of performing the specified function without any alteration, rather than merely having potential to perform the specified function after further modification. In other words, the system, apparatus, structure, article, element, component, or hardware “configured to” perform a specified function is specifically selected, created, implemented, utilized, programmed, and/or designed for the purpose of performing the specified function. As used herein, “configured to” denotes existing characteristics of a system, apparatus, structure, article, element, component, or hardware which enable the system, apparatus, structure, article, element, component, or hardware to perform the specified function without further modification. For purposes of this disclosure, a system, apparatus, structure, article, element, component, or hardware described as being “configured to” perform a particular function may additionally or alternatively be described as being “adapted to” and/or as being “operative to” perform that function.

The schematic flow chart diagrams and method schematic diagrams described above are generally set forth as logical flow chart diagrams. As such, the depicted order and labeled steps are indicative of representative embodiments. Other steps, orderings and methods may be conceived that are equivalent in function, logic, or effect to one or more steps, or portions thereof, of the methods illustrated in the schematic diagrams.

Additionally, the format and symbols employed are provided to explain the logical steps of the schematic diagrams and are understood not to limit the scope of the methods illustrated by the diagrams. Although various arrow types and line types may be employed in the schematic diagrams, they are understood not to limit the scope of the corresponding methods. Indeed, some arrows or other connectors may be used to indicate only the logical flow of a method. For instance, an arrow may indicate a waiting or monitoring period of unspecified duration between enumerated steps of a depicted method. Additionally, the order in which a particular method occurs may or may not strictly adhere to the order of the corresponding steps shown.

The present subject matter may be embodied in other specific forms without departing from its spirit or essential characteristics. The described embodiments are to be considered in all respects only as illustrative and not restrictive. All changes which come within the meaning and range of equivalency of the claims are to be embraced within their scope.

In the above description, specific details of various embodiments are provided. However, some embodiments may be practiced with less than all of these specific details. In other instances, certain methods, procedures, components, structures, and/or functions are described in no more detail than to enable the various embodiments of the invention, for the sake of brevity and clarity.

Although specific embodiments of the invention have been described and illustrated, the invention is not to be limited to the specific forms or arrangements of parts so described and illustrated. The scope of the invention is to be defined by the claims appended hereto and their equivalents.

What is claimed is:

1. An apparatus for puncturing an epidermis with controlled fluid delivery, the apparatus comprising a needle cartridge attached to and interfacing with an actuating device, the cartridge comprising:

## 15

- a housing assembly forming a fluid cavity and comprising a first aperture at a tip of the housing assembly and a second aperture opposite the first aperture;
- a needle group assembly comprising a needle, wherein:  
 the needle group assembly is configured to move in a reciprocating motion relative to the housing assembly along an axis from the first aperture to the second aperture,  
 the needle is configured to fully retract into the fluid cavity through the first aperture during the reciprocating motion, and  
 the needle is configured to extend into a patient's skin at a repeatable depth by resting the tip of the housing assembly on the patient's skin during the reciprocating motion;
- a needle group housing that forms a needle group cavity and separates the fluid cavity from the needle group cavity, wherein:  
 the needle group housing comprises a fourth aperture through which the needle passes,  
 the needle is configured to fully retract into the needle group housing through the fourth aperture during the reciprocating motion,  
 and the needle group housing surrounding the fourth aperture is configured to remove dermal debris from the needle during the reciprocating motion; and
- a fluid port integrated with the housing assembly and comprising a third aperture.
2. The apparatus of claim 1, wherein the tip of the housing assembly is configured to push the dermal debris aside.
3. The apparatus of claim 1, wherein the tip of the housing assembly can be moved transversely across the surface of the skin without catching or snagging the skin when the needle is in a fully retracted position.

## 16

4. The apparatus of claim 1, wherein the first aperture is configured to dislodge dermal debris from the needle upon full retraction.
5. The apparatus of claim 1, wherein the needle cartridge further comprises an internal seal forming a seal between the first aperture and the second aperture.
6. The apparatus of claim 1, wherein the needle group assembly further comprises a needle holder.
7. The apparatus of claim 6, wherein the needle holder comprises a shaft protruding beyond the second aperture.
8. The apparatus of claim 1, wherein the housing assembly comprises an outer housing, the needle group housing, and a needle holder housing, wherein the outer housing comprises the fluid port and first aperture.
9. The apparatus of claim 1, wherein the housing assembly comprises an outer housing, the needle group housing, and a needle holder housing, wherein the outer housing comprises the fluid port and first aperture, and wherein the needle holder housing comprises the second aperture.
10. The apparatus of claim 1, wherein an inner surface of the outer housing and an outer surface of the needle group housing form the fluid cavity.
11. The apparatus of claim 1, wherein the needle comprises a needle group comprising a plurality of needles side by side.
12. The apparatus of claim 1, further comprising a bearing that engages the needle group assembly, allows a linear reciprocating motion of the needle group assembly, and prevents radial motion of the needle group assembly.
13. The apparatus of claim 1, wherein the fluid port further comprises a hollow projection forming a conduit.

\* \* \* \* \*