



US011528564B2

(12) **United States Patent**  
**Higgins et al.**

(10) **Patent No.:** **US 11,528,564 B2**  
(45) **Date of Patent:** **Dec. 13, 2022**

(54) **HEARING DEVICE CABLE**

- (71) Applicant: **Starkey Laboratories, Inc.**, Eden Prairie, MN (US)
- (72) Inventors: **Sidney A. Higgins**, Maple Grove, MN (US); **David Tourtelotte**, Eden Prairie, MN (US)
- (73) Assignee: **Starkey Laboratories, Inc.**, Eden Prairie, MN (US)
- (\*) Notice: Subject to any disclaimer, the term of this patent is extended or adjusted under 35 U.S.C. 154(b) by 410 days.

- (21) Appl. No.: **16/235,629**
- (22) Filed: **Dec. 28, 2018**

- (65) **Prior Publication Data**  
US 2019/0208332 A1 Jul. 4, 2019

**Related U.S. Application Data**

- (60) Provisional application No. 62/611,346, filed on Dec. 28, 2017.
- (51) **Int. Cl.**  
*H04R 25/02* (2006.01)  
*H04R 25/00* (2006.01)
- (52) **U.S. Cl.**  
CPC ..... *H04R 25/02* (2013.01); *H04R 25/65* (2013.01); *H04R 25/70* (2013.01); *H04R 2225/0213* (2019.05)
- (58) **Field of Classification Search**  
CPC ..... H04R 1/105; H04R 2225/021; H04R 2225/63  
USPC ..... 381/330, 381  
See application file for complete search history.

(56) **References Cited**

U.S. PATENT DOCUMENTS

8,374,376 B2 *	2/2013	Kurbis .....	H04R 1/083 381/381
8,411,890 B2 *	4/2013	Ooi .....	H04R 25/60 381/330
2003/0002700 A1	1/2003	Fretz et al.	
2006/0023909 A1	2/2006	Grafenberg	
2008/0247590 A1	10/2008	Sun	
2009/0087006 A1	4/2009	Leong	
2010/0104126 A1	4/2010	Greene	

(Continued)

OTHER PUBLICATIONS

Invitation to Pay Additional Fees, Partial Search and Provisional Opinion for International Patent Application No. PCT/US2018/067908, Mar. 14, 2019; 11 pages.

(Continued)

*Primary Examiner* — Suhan Ni

(74) *Attorney, Agent, or Firm* — Mueting Raasch Group

(57) **ABSTRACT**

A hearing device cable including a body portion is described herein. The body portion may extend between a first end region and a second end region along a tube centerline. The body portion may include a first radial portion proximate the first end region and second radial portion proximate the second end region. The first radial portion may define a radius of curvature that is greater than or equal to a radius of curvature defined by the second radial portion. The tube centerline may lie along an x-y plane between the first and second end regions. In one or more embodiments, the body portion may define a passageway extending between the first and second end regions. Further, the hearing device cable may include a superelastic wire within the passageway extending between the first and second end regions.

**9 Claims, 11 Drawing Sheets**

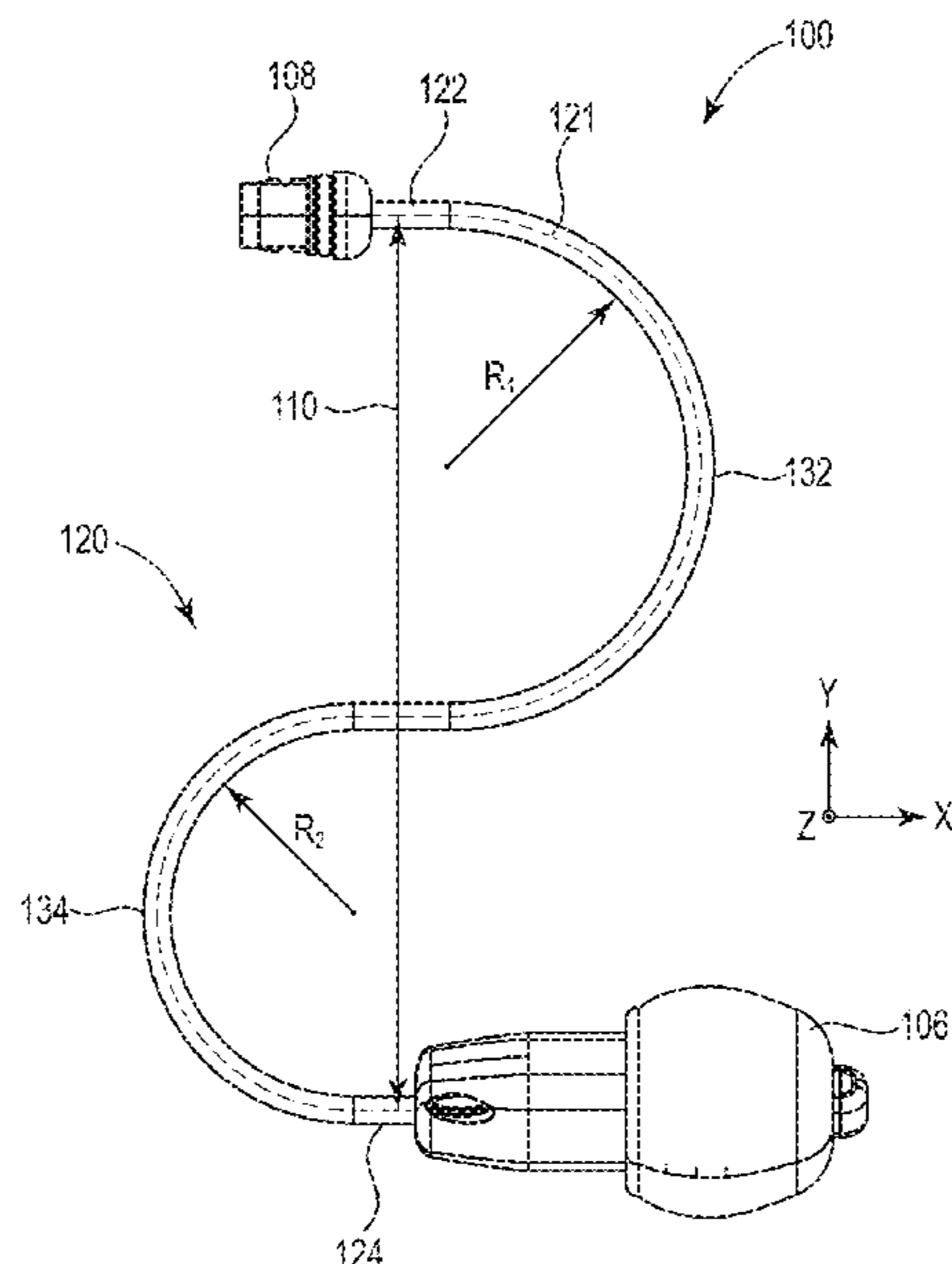

(56)

**References Cited**

U.S. PATENT DOCUMENTS

2011/0135131 A1 6/2011 Winther  
2012/0014547 A1 1/2012 Sjursen et al.  
2013/0238079 A1 9/2013 Bingener-Casey et al.  
2014/0025138 A1 1/2014 Meskens et al.  
2014/0294214 A1\* 10/2014 Zhao ..... H04R 25/656  
381/330  
2015/0237453 A1 8/2015 Kaminski et al.  
2016/0296755 A1 10/2016 Van Der Borghet et al.  
2017/0238079 A1 8/2017 Smith et al.

OTHER PUBLICATIONS

Office Action issued in Europe for Application No. 18840002.2  
dated Jun. 18, 2021 (9 pages).

\* cited by examiner

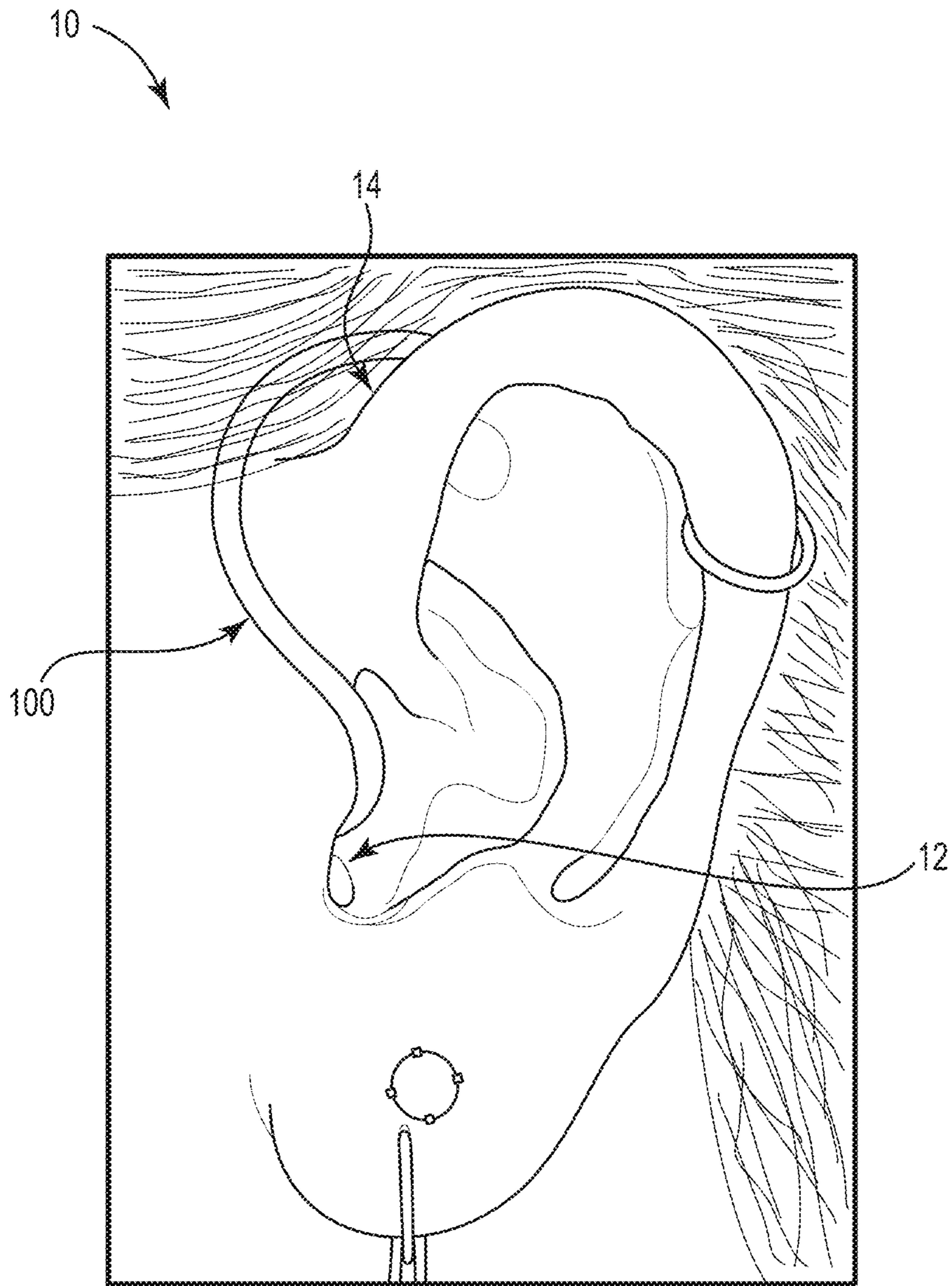

FIG. 1A

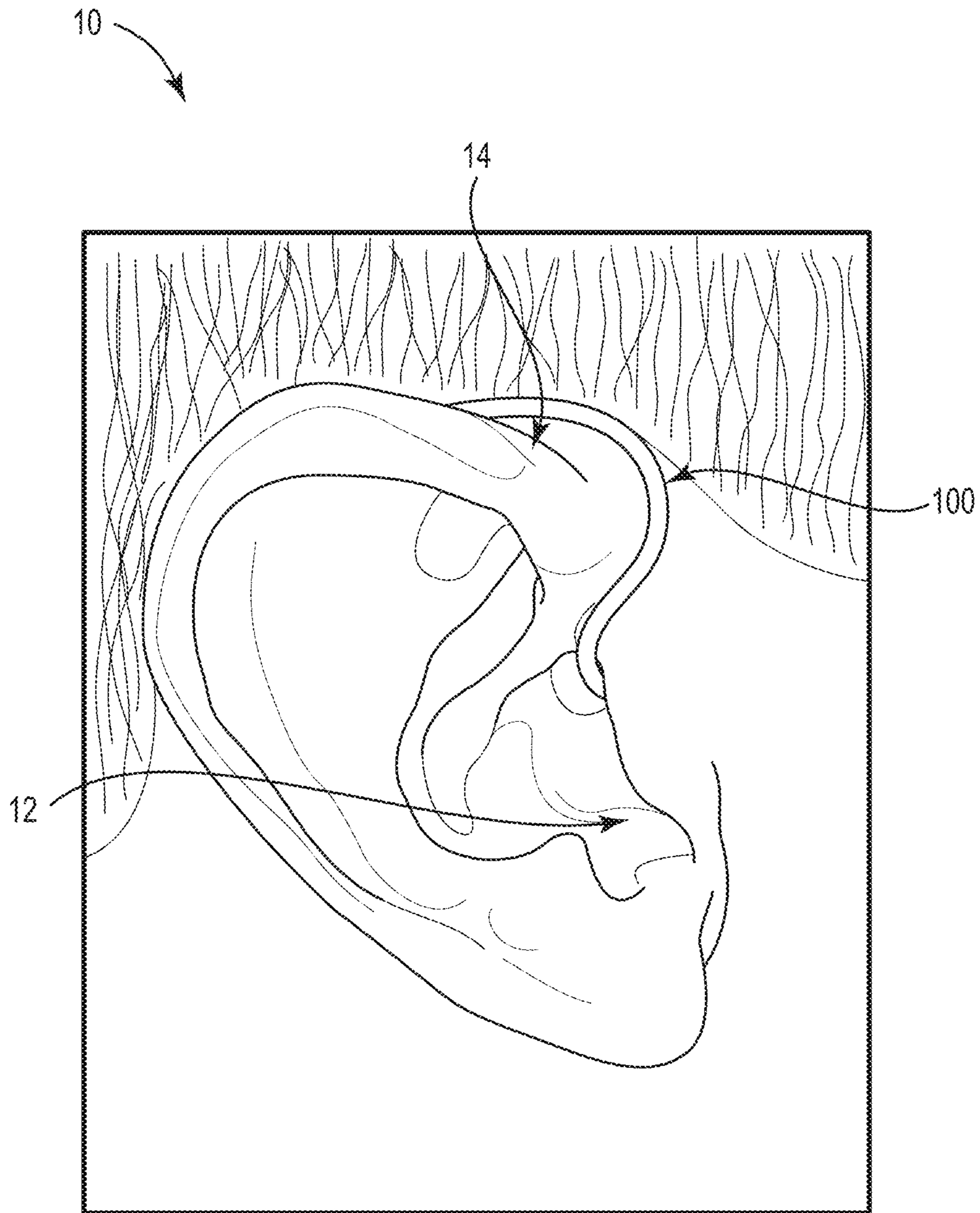

FIG. 1B

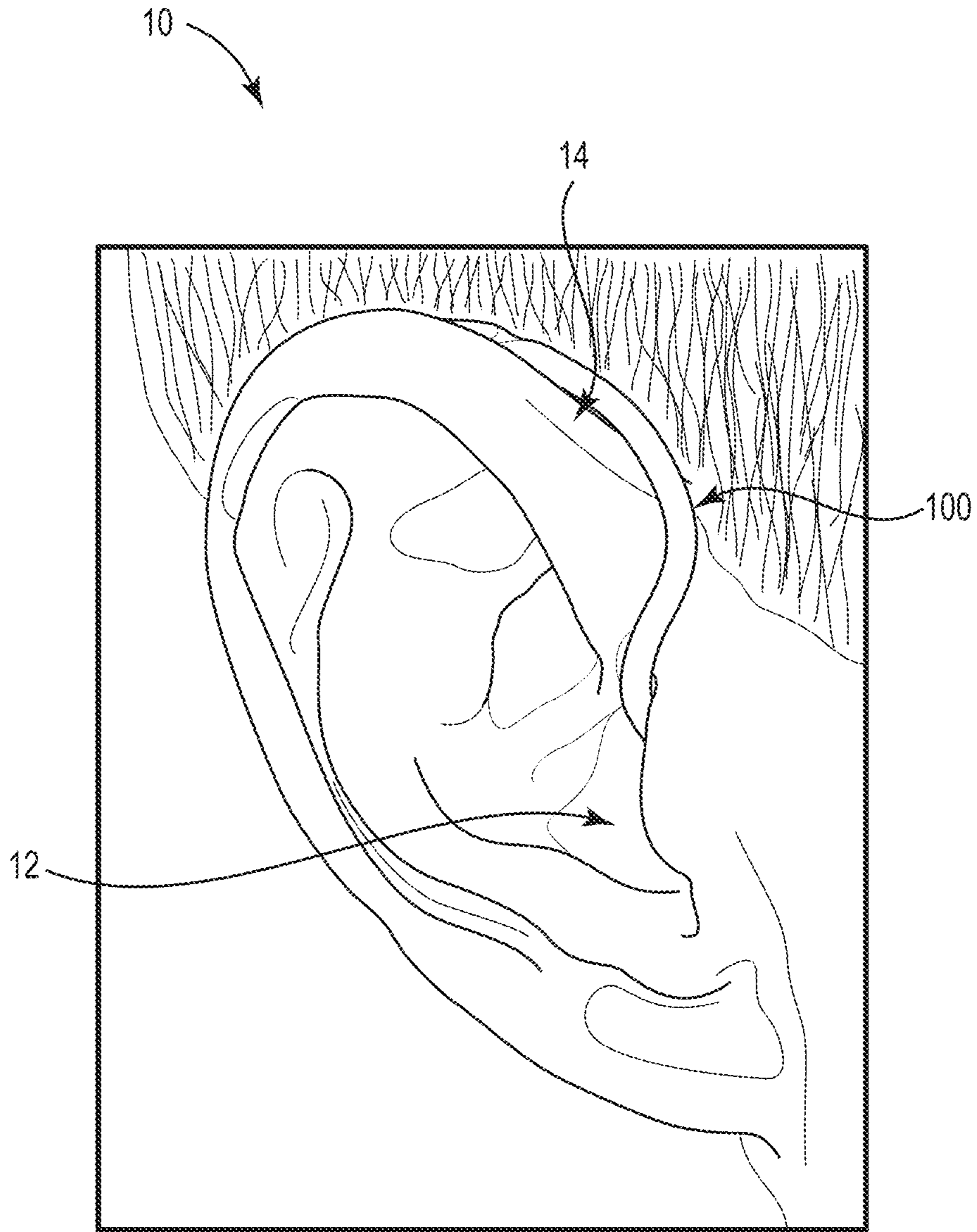

FIG. 1C

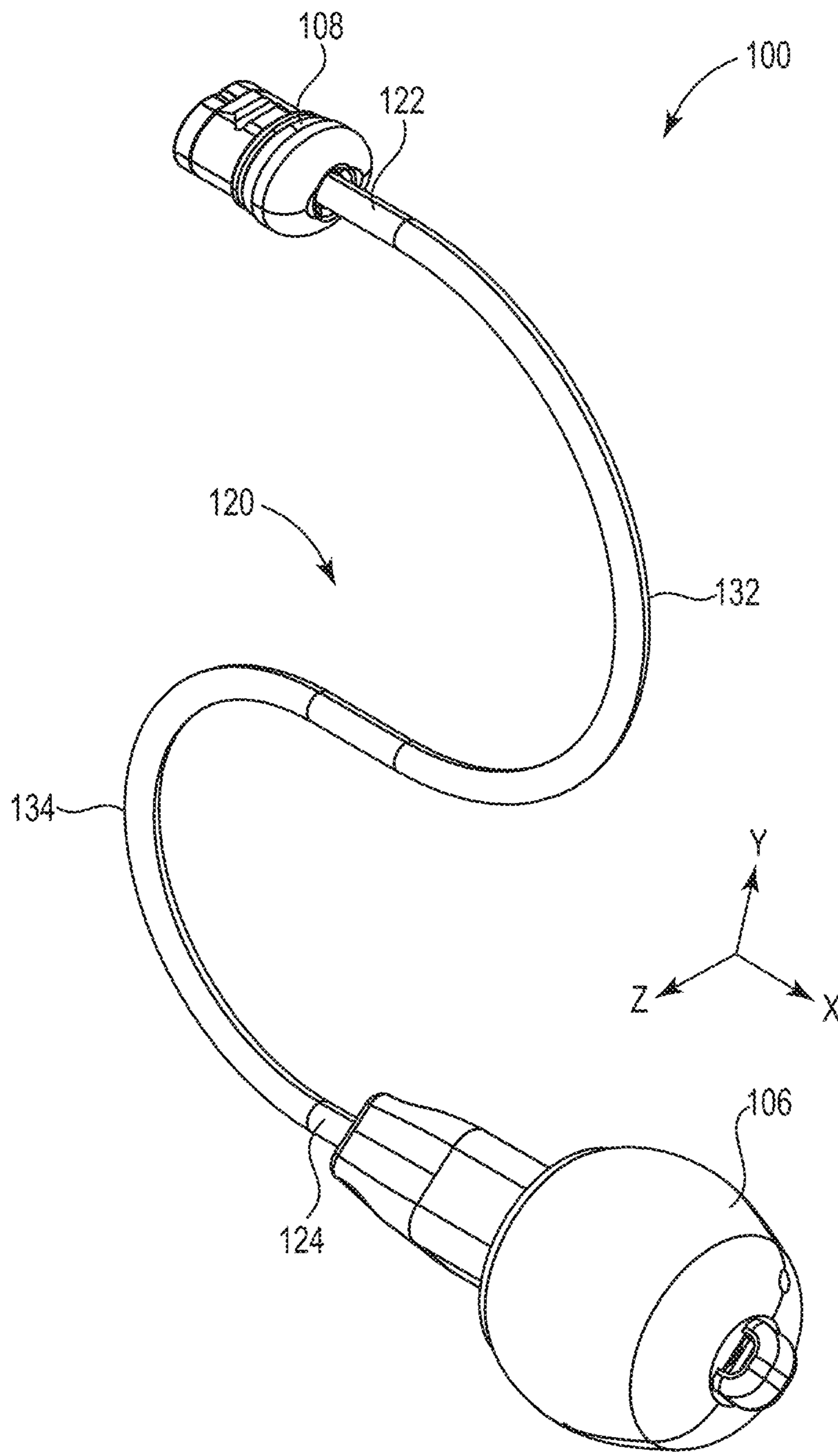

FIG. 2A

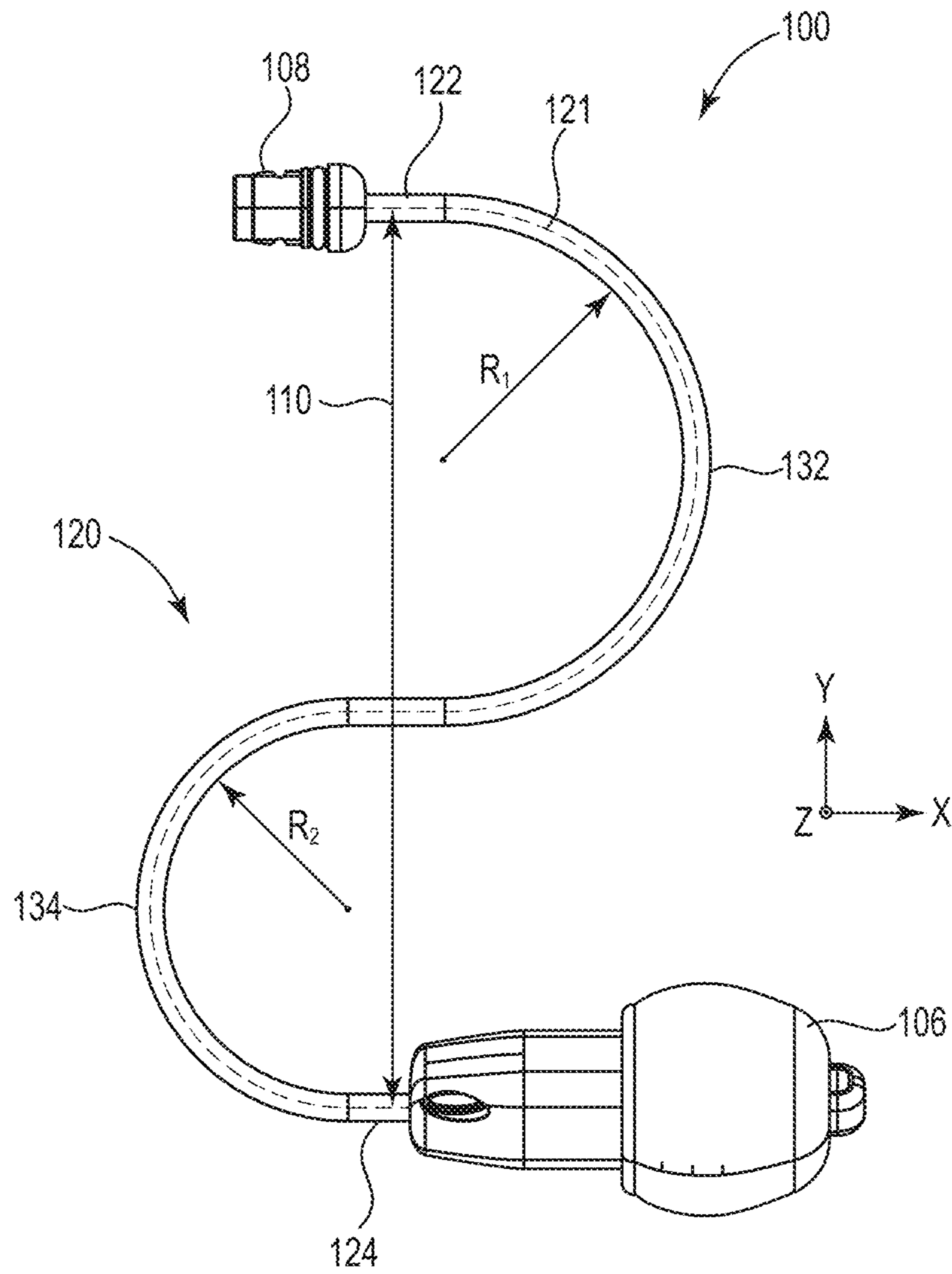

FIG. 2B

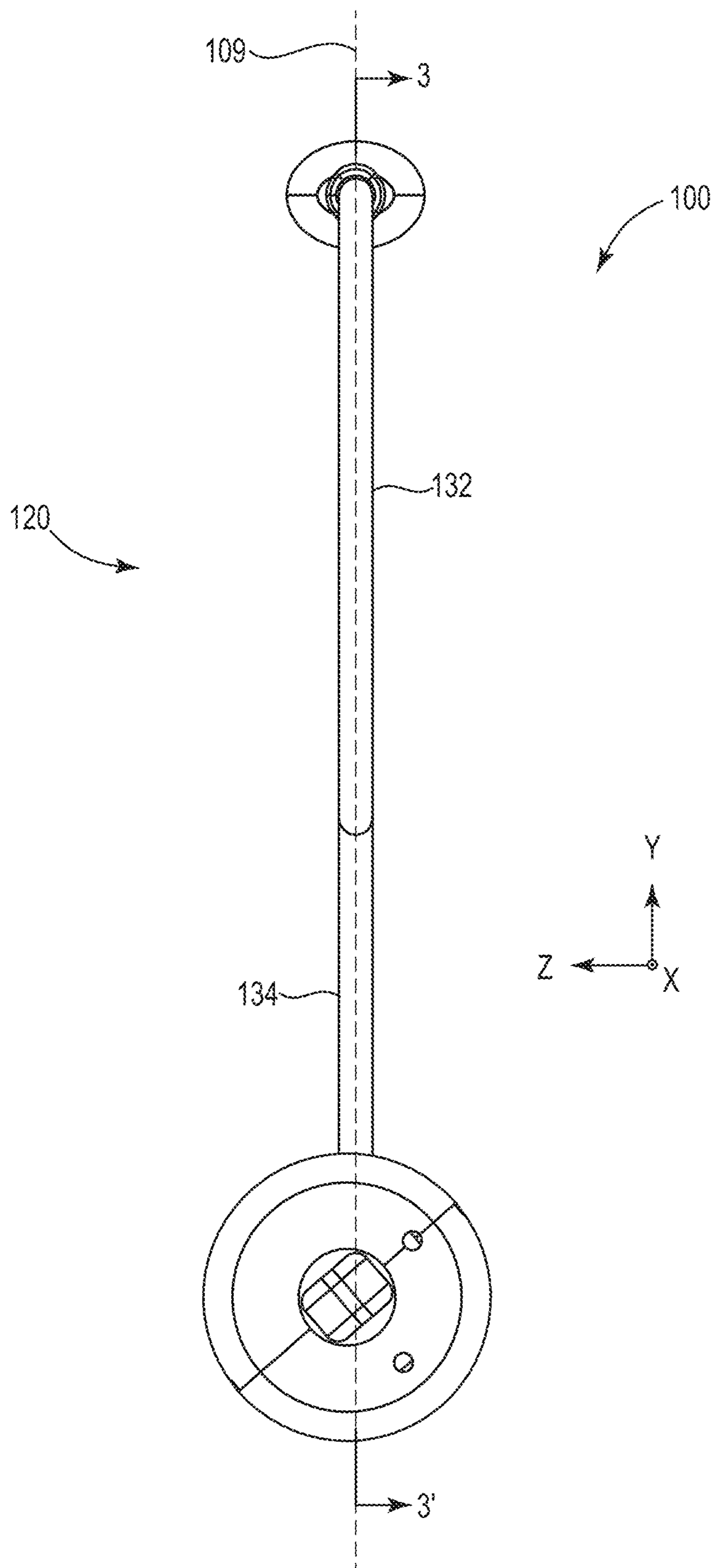

FIG. 2C



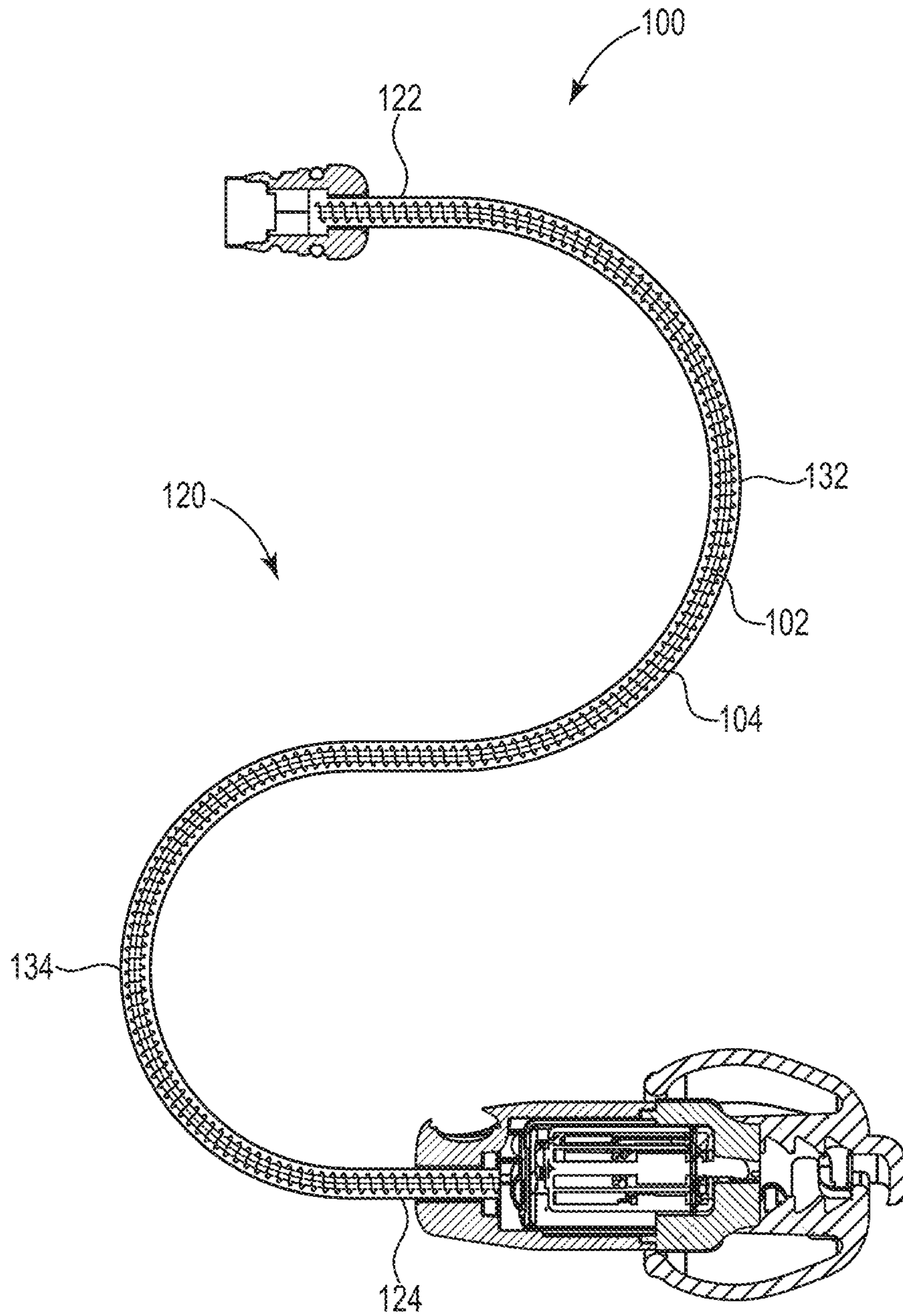

FIG. 3

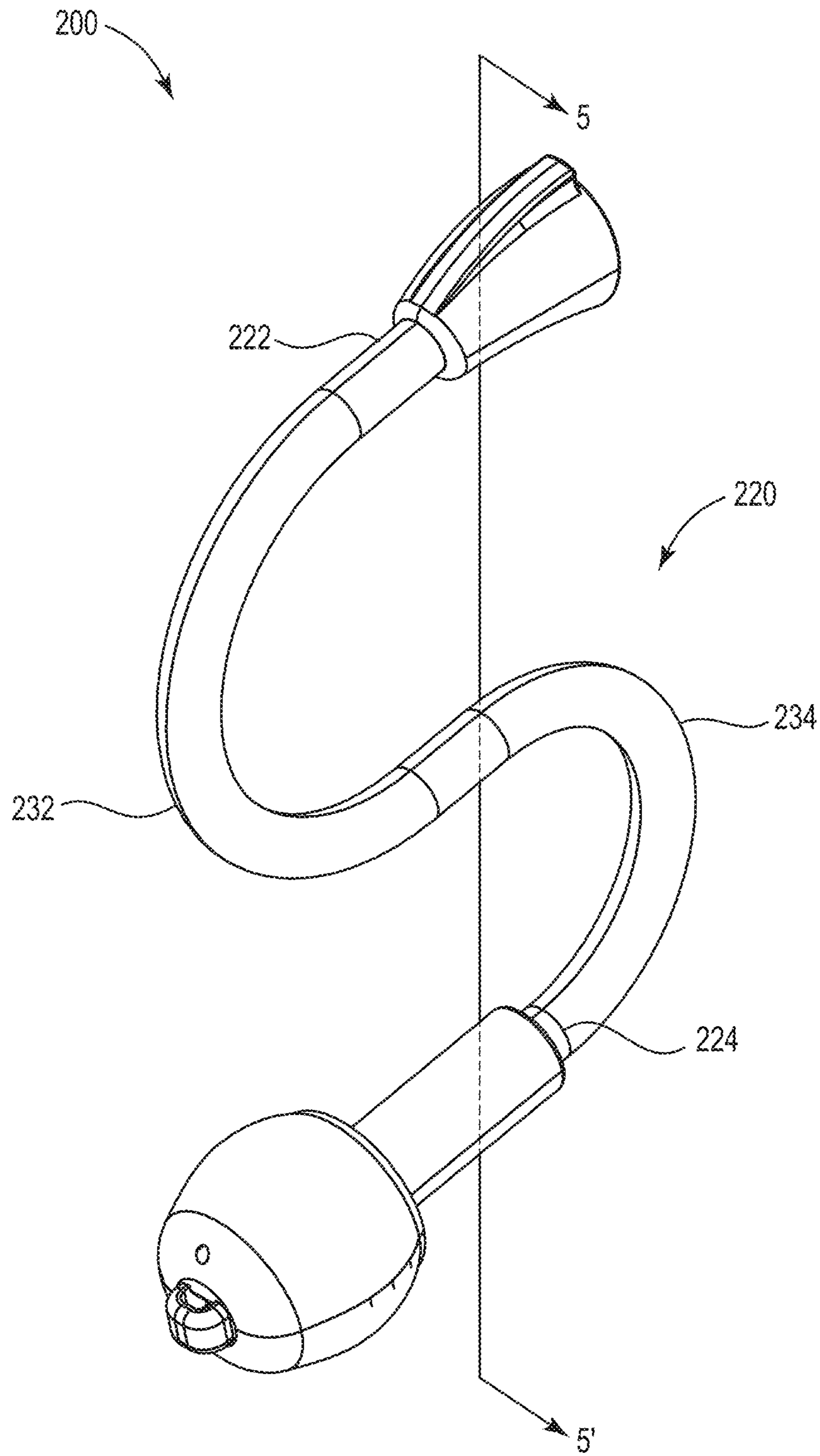

FIG. 4A

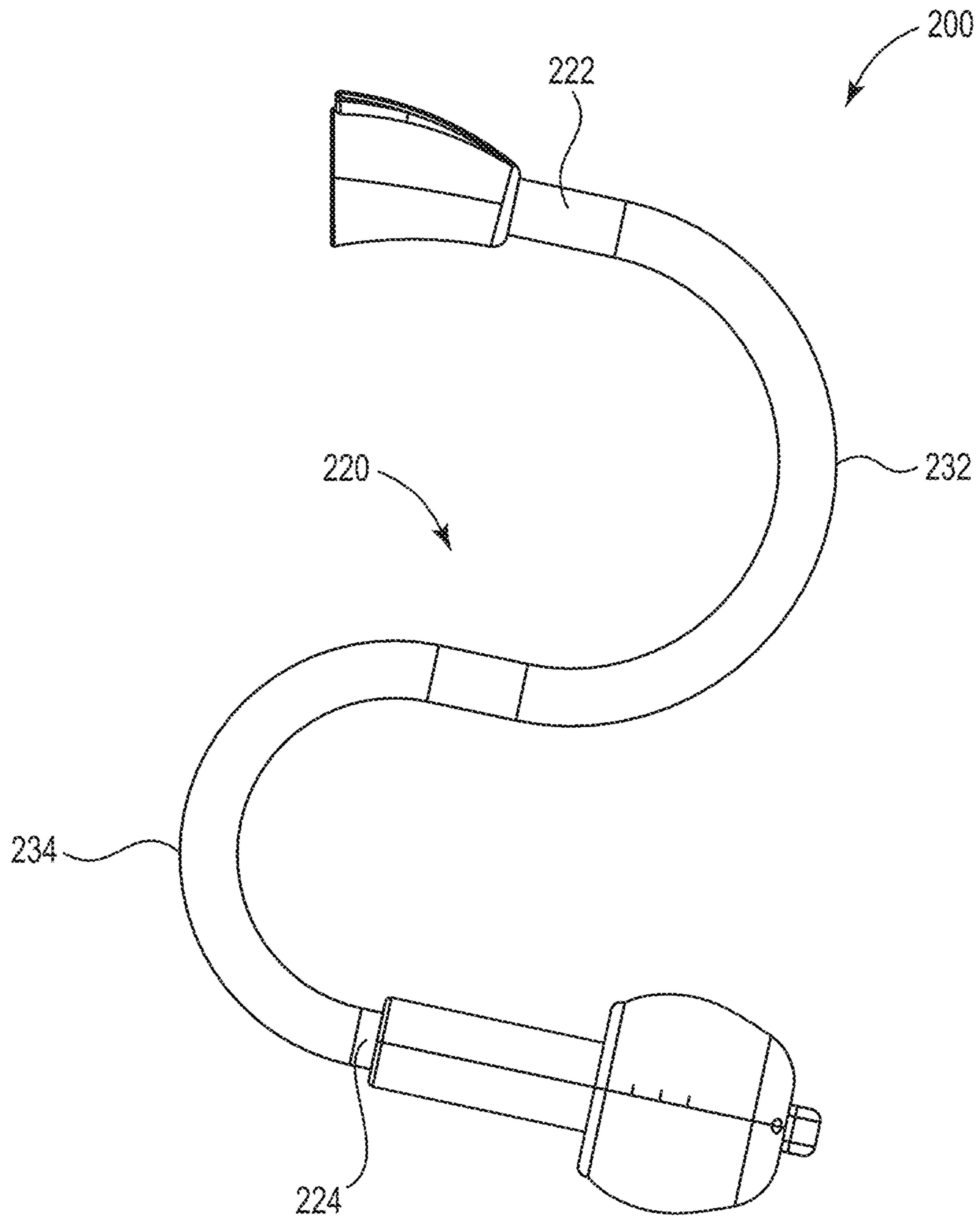

FIG. 4B

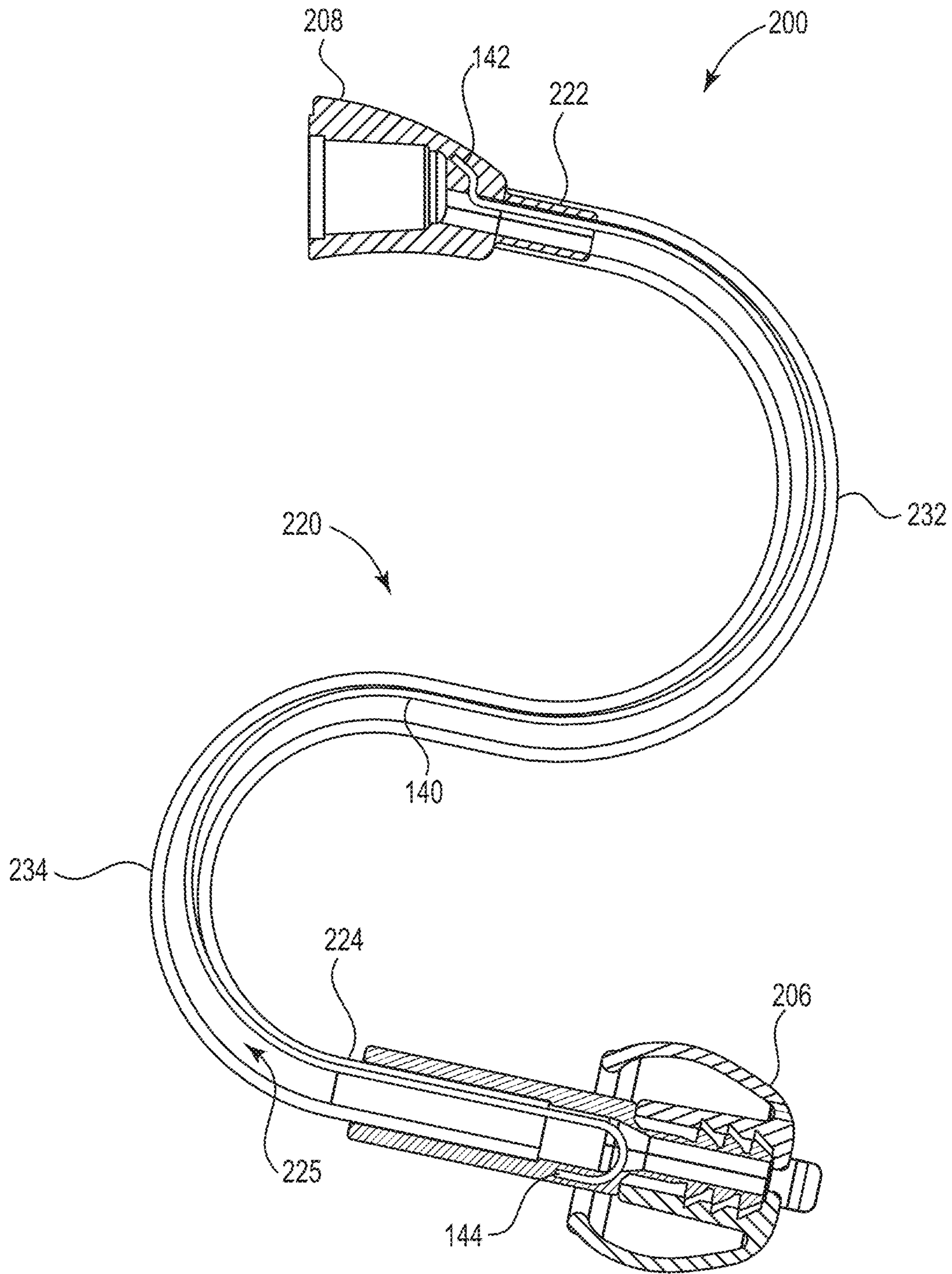

FIG. 5A

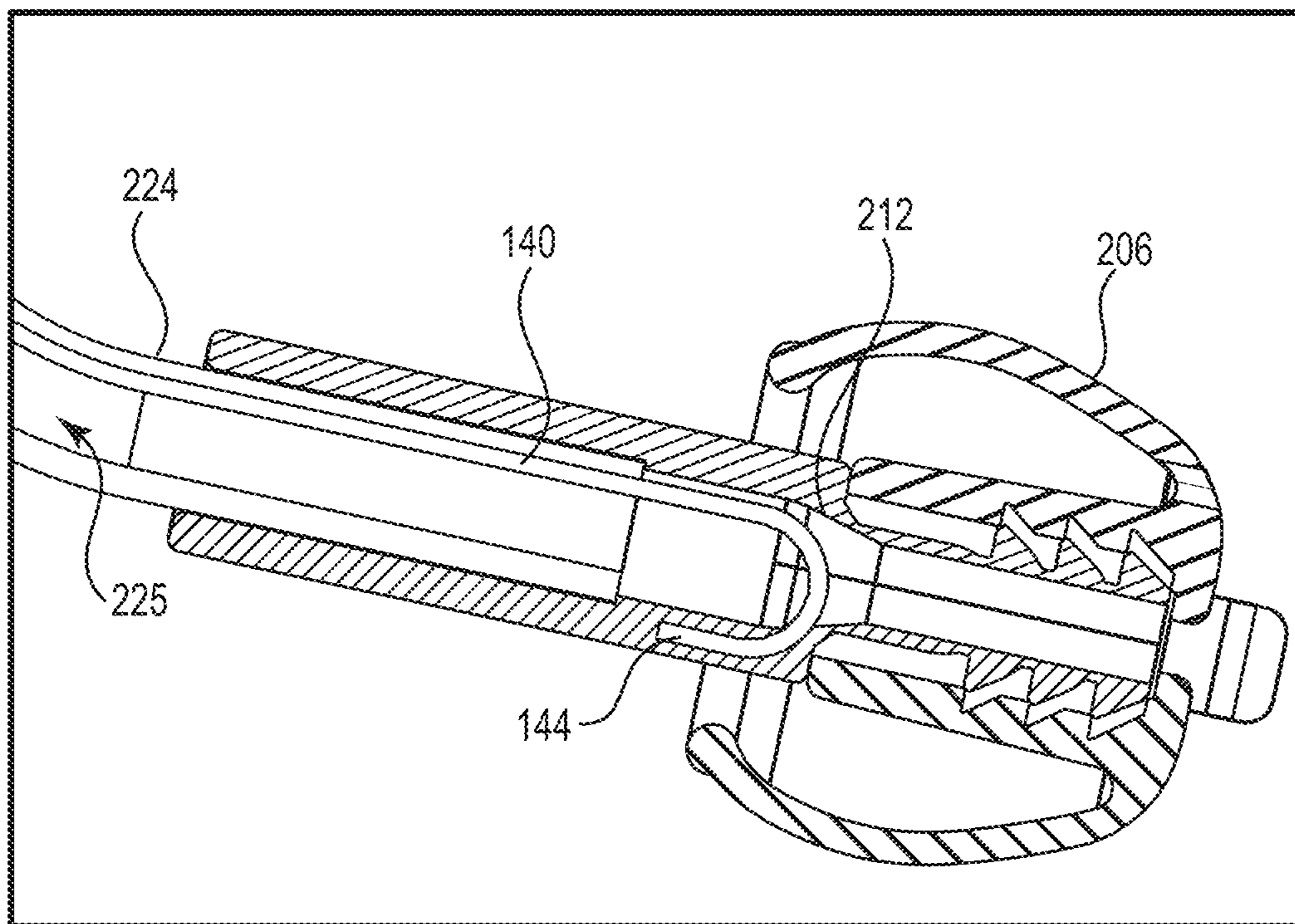

FIG. 5B

**1****HEARING DEVICE CABLE**

## RELATED APPLICATION

This application claims the benefit of U.S. Provisional Application No. 62/611,346, filed 28 Dec. 2017, and entitled HEARING DEVICE CABLE, which is incorporated herein by reference in its entirety.

## FIELD OF THE DISCLOSURE

Embodiments of the present disclosure relate generally to hearing device cables.

## BACKGROUND

Hearing devices (e.g., including hearing aids or devices for providing personalized sound to an individual's ear) may be worn, for example, in and/or around an individual's ear and may be contoured with curved surfaces to facilitate comfort in use. For example, hearing aids may be used to assist an individual suffering from hearing loss by transmitting amplified sound directly to the individual's ear canals. Specifically, for example, hearing aids may be in the form of a Receiver in Canal (MC) device or a Behind the Ear (BTE) device. BTE devices may require tubing to direct processed audio from an ear piece (e.g., positioned on top of the ear) to the ear canal. MC devices may require routing the hearing device wires or cables from the speaker inside the ear canal to the device residing behind the ear. The hearing device cable generally follows the contours of the head (e.g., along the ear) prior to an approximately 90 degree turn into the ear canal. This produces a hearing device that substantially extends in all three dimensions and forms a significant bend that may kink and/or tension the cable/tube to create a compound failure mode (e.g., which may result in broken cables/tubes, broken wires, intermittent connections, or any combinations thereof).

With respect to both the RIC device and the BTE device, the cables or tubing may be specifically shaped and sized to best fit the user's anatomy. As a result, multiple sizes and shapes of each hearing device must be manufactured for the multiple different possible user anatomies. As a result, consumer self-fitting may not be practical without having all the different size and shape hearing devices on hand. Even using one of the multiple different shape and sized hearing devices, the hearing device may have slight mismatches to the user's anatomy that affect retention and comfort of the hearing device. Further, each size and shape must also include a mirror image to accommodate for a hearing device in each user's ear (e.g., a hearing device for the right ear and a hearing device for the left ear). Further yet, manufacturing multiple different size and shape hearing devices (as well as left and right variants) may require several handling steps, processes, fixtures, and checks to ensure compliance. Additionally, custom packaging may need to be specifically tailored to each variant of hearing device to ensure protection of the hearing devices during shipment.

With respect to BTE devices, it is important to eliminate variations in acoustic paths that are not accounted for in the programming software. Therefore, typically, the BTE device includes either an earhook, custom length tubing and a 90 degree elbow all compression fit together in varying lengths or a thin tube thread interface, shaped tubing of varying lengths, and a barbed interface all bonded in the left or right configurations. Further, the earhook assemblies are large in cross-section and the overlapping joints from the hook to the

**2**

tube may draw attention (e.g., giving the BTE device a "stodgy" or "old fashioned" appearance). Further yet, the thin tube assemblies commonly kink during use and transportation, which may severely shorten service life.

## SUMMARY

Embodiments described herein may provide a hearing device cable (e.g., a tube) that defines a distinct shape and flexibility to provide a one-size-fits-all (ear anatomies) device. In other words, the hearing device cable may be flexible enough to contour along both left and right ears of different sizes, while still maintaining a stiffness necessary for the hearing device. Further, the hearing device cables (or tubes) may include a superelastic wire contained therein to help define the distinct shape of the hearing device cable.

In one embodiment, a hearing device cable may include a body portion extending between a first end region and a second end region. The body portion may include a first radial portion proximate the first end region and a second radial portion proximate the second end region. The first radial portion may define a radius of curvature that is greater than or equal to a radius of curvature defined by the second radial portion.

In another embodiment, a hearing device cable may include a body portion extending between a first end region and a second end region along a tube centerline. The body portion may include a first radial portion proximate the first end region and a second radial portion proximate the second end region. The tube centerline may lie along an x-y plane between the first and second end regions.

In one or more embodiments, the radius of curvature of the first radial portion may be greater than or equal to 100% and/or less than or equal to 200% of the radius of curvature of the second radial portion. In one or more embodiments, the body portion may define an S-shape such that the first radial portion extends along an arc that curves in a direction opposite an arc along which the second radial portion extends. In one or more embodiments, the body portion may include one or more conductive wires and Kevlar. In one or more embodiments, the body portion may be adapted to fit within a human ear (e.g., left or right ear) such that the first end region is positioned above the human ear and the second end region is positioned within an ear canal of the human ear. In one or more embodiments, the body portion may be adapted to deflect such that a direct distance between the first end region and the second end region increases or decreases (e.g., to fit various sized ears).

In one or more embodiments, the body portion may include a UV resistant material. In one or more embodiments, the body portion may be configured to retain shape after deformation. In one or more embodiments, the cable may be configurable in a relaxed state and a deflected state, wherein a direct distance between the first end region and the second end region may be different in the relaxed state than the deflected state. In one or more embodiments, the body portion may define a passageway extending between the first end region and the second end region. In one or more embodiments, the cable may further include a superelastic wire within the passageway extending between the first end region and the second end region. In one or more embodiments, the cable may further include an ear interface coupled to the second end region of the body portion.

In yet another embodiment, a hearing device cable may include a body portion and a superelastic wire. The body portion may extend between a first end region and a second end region. The body portion may define a passageway

extending between the first end region and the second end region. The superelastic wire may be within the passageway extending between the first end region and the second end region (e.g., coupled to each of the first and second end regions).

In one or more embodiments, the superelastic wire may include nitinol. In one or more embodiments, the superelastic wire may be folded at the second end region of the body portion. In one or more embodiments, the cable may further include an ear interface proximate the second end region of the body portion defining a chamfer/taper. In one or more embodiments, the body portion may include a silicone material. In one or more embodiments, the superelastic wire may define a deformation temperature greater than or equal to 500 degrees Fahrenheit.

In one or more embodiments, the body portion may define a constant interior length and inside diameter between the first end region and the second end region. In one or more embodiments, the body portion may include a first radial portion proximate the first end region and a second radial portion proximate the second end region, wherein the first radial portion may define a radius of curvature that is greater than or equal to a radius of curvature defined by the second radial portion. In one or more embodiments, the body portion may include a first radial portion proximate the first end region and a second radial portion proximate the second end region, wherein the tube centerline or curved axis may lie along an x-y plane between the first and second end regions.

The above summary is not intended to describe each embodiment or every implementation. Rather, a more complete understanding of illustrative embodiments will become apparent and appreciated by reference to the following Detailed Description of Exemplary Embodiments and Claims in view of the accompanying figures of the drawing.

#### BRIEF DESCRIPTION OF THE VIEWS OF THE DRAWING

Exemplary embodiments will be further described with reference to the figures of the drawing, wherein:

FIGS. 1A-1C are side views of various different human ears including an illustrative hearing device cable positioned thereon;

FIG. 2A is a perspective view of an illustrative hearing device cable and in accordance with embodiments of the present disclosure;

FIG. 2B is a side view of the hearing device cable of FIG. 2A;

FIG. 2C is a front view of the hearing device cable of FIG. 2A;

FIG. 3 is a cross-sectional view of the hearing device cable of FIG. 2A taken along line 3-3' of FIG. 2C;

FIG. 4A is a perspective view of another illustrative hearing device cable and in accordance with embodiments of the present disclosure;

FIG. 4B is a side view of the hearing device cable of FIG. 4A;

FIG. 5A is a cross-sectional view of the hearing device cable of FIG. 4A taken along line 5-5' of FIG. 4A; and

FIG. 5B is an enlarged view of the hearing device cable of FIG. 5A.

The figures are rendered primarily for clarity and, as a result, are not necessarily drawn to scale. Moreover, various structure/components, including but not limited to fasteners, electrical components (wiring, cables, etc.), and the like, may be shown diagrammatically or removed from some or

all of the views to better illustrate aspects of the depicted embodiments, or where inclusion of such structure/components is not necessary to an understanding of the various exemplary embodiments described herein. The lack of illustration/description of such structure/components in a particular figure is, however, not to be interpreted as limiting the scope of the various embodiments in any way. Still further, "Figure x" and "FIG. x" may be used interchangeably herein to refer to the figure numbered "x."

#### DETAILED DESCRIPTION OF EXEMPLARY EMBODIMENTS

In the following detailed description of illustrative embodiments, reference is made to the accompanying figures of the drawing which form a part hereof. It is to be understood that other embodiments, which may not be described and/or illustrated herein, are certainly contemplated. Unless otherwise indicated, all numbers expressing quantities, and all terms expressing direction/orientation (e.g., vertical, horizontal, parallel, perpendicular, etc.) in the specification and claims are to be understood as being modified in all instances by the term "about."

Generally speaking, embodiments of the present disclosure may be directed to hearing device cables that define a distinct shape (e.g., an S-shape) such that the hearing device cable expands or contracts in multiple directions to allow for the adaption and compliance to different ear anatomies. In other words, the distance between each end of the hearing device cable remains constant (e.g., measured along the cable), but the cable flexes to accommodate various sized ears. Furthermore, the hearing device cable lies in a generally planar dimension when the cable is in a relaxed state. In other words, the hearing device cable only extends generally in two coordinate directions and does not substantially extend into the third coordinate direction that is orthogonal to the plane in which the cable lies. As a result, the hearing device cable, as described herein, does not extend at a 90-degree angle that may be susceptible to kinking or breaking.

Specifically, the hearing device cable may define an S-shape including an upper curve (e.g., the portion to be positioned proximate the top of the ear) that is larger than a lower curve (e.g., the portion to be positioned proximate the ear canal). These curved portions of the hearing device cable may allow for expansions and contractions of the cable. The lower curve may permit a gradual in-situ bend into the ear canal to, e.g., minimize the resulting projection from the ear while reducing the stress inflicted on the cable and components (e.g., wires) contained therein. The upper curve may have a slightly larger bend to accommodate for extending around the ear to the top of the ear. As such the upper and lower curves may help to improve comfort to the user by gently conforming to the anatomy of the user.

The hearing device cables may contain any components to help define the distinct shape. For example, in some embodiments, the cable may include an extruded material (e.g., extruded Pebax) that encases multiple wires and Kevlar strands/braids to enhance pull strength and define the flexibility/rigidity of the cable (while decreasing the possibility of broken wires due to overextension). In other embodiments, the hearing device cable may be a tube that includes a transparent silicone (or equivalent TPE) soft flexible tube placed over a pre-shaped superelastic nitinol wire that provides structure to the tube. In other words, the superelas-

5

tic wire remains within the tube of the hearing device cable to act as an internal “spine” that forms the distinct shape (e.g., the S-shape).

With reference to the figures of the drawing, wherein like reference numerals designate like parts and assemblies throughout the several views, FIGS. 1A-1C illustrate various different human ears 10 including an illustrative hearing device cable 100 positioned thereon. The hearing device cable 100 extends between an ear canal 12 and a location above the ear (e.g., the pinna 14) and adapts to various distances between the ear canal 12 and the pinna 14 depending on the user. Because the hearing device cable 100 defines an upper curve and a lower curve, as described further herein, the hearing device cable 100 may extend or contract to fit the ear anatomy of any user as shown in FIGS. 1A-1C. Further, the shape of the hearing device cable 100 is suitable for either the left or right ear. For example, the hearing device cable 100 used in FIGS. 1B and 1C is positioned on a right ear and the hearing device cable 100 used in FIG. 1A is positioned on a left ear. This applicability of a single hearing device cable 100 to either of the left ear or the right ear may eliminate the need for separate left and right cables (e.g., may eliminate the need for two distinct hearing device cables). As a result, the hearing device cable 100 may be described as a “universal solution” or one-size-fits-all device (e.g., due to the cable/tube geometry) that may enable a better consumer experience by eliminating the need for fitting the hearing device cable to the user (e.g., to accommodate the shape and/or size of the ear or to fit the left/right ear). Further, the hearing device cable 100 may allow device compatibility with small and thin recharging accessories.

As shown in FIGS. 2-3, the hearing device cable 100 may include a body portion 120 extending between a first end region 122 and a second end region 124. Specifically, the body portion 120 may extend between the first end region 122 and the second end region 124 along a tube centerline 121 or a curved axis (e.g., as shown in FIG. 2B). The body portion 120 may be any suitable cable or tube used with a hearing device. For example, the body portion 120 may include an extruded cable that increases environmental resistance because, e.g., both ends are sealed. Specifically, the body portion 120 may be a conduit for wires (e.g., for a RIC device) and may be shaped from the external jacket via heat forming. Further, the body portion 120 may include one or more conductive wires 102 and Kevlar 104 (e.g., as shown in FIG. 3). The one or more conductive wires 102 may operably connect the ear piece and the receiver and the Kevlar 104 (as well as the one or more conductive wires 102) may increase the pull strength (e.g., up to 20 pounds of force) and ruggedness (e.g., improved tensile strength) of the body portion 120. In other embodiments, the body portion 120 may include a tube (e.g., formed from silicone) that defines a passageway therethrough (e.g., between the first end region 122 and the second end region 124). In some embodiments, the body portion 120 may include a UV resistant material. Regardless of the components of the body portion 120, the body portion 120 may always maintain its shape with minimal resistance (e.g., after deformation).

The body portion 120 may extend a length along the tube centerline 121 between the first and second end regions 122, 124. The length of the body portion 120 may remain constant regardless of the deformation of the body portion 120. As such, internal components contained within the body portion 120 (e.g., one or more conductive wires 102) may not be strained due to deformation of the body portion

6

120 and sound characteristics that depend on a set distance (e.g., BTE devices) will not be affected by any deformation of the body portion 120.

The body portion 120 may include a first radial portion 132 proximate the first end region 122 and a second radial portion 134 proximate the second end region 124. The first radial portion 132 may define a radius of curvature R1 and the second radial portion 134 may define a radius of curvature R2. Further, it may be described that the body portion 120 defines an S-shape such that the first radial portion 132 extends along an arc that curves in a direction opposite an arc along which the second radial portion 134 extends. In other words, as shown in FIG. 2B, a concave side of the first radial portion 132 (e.g., facing left in FIG. 2B) faces opposite a concave side of the second radial portion 134 (e.g., facing right in FIG. 2B).

The hearing device cable 100 may be configured or adapted into a relaxed state and a deflected state. For example, when the hearing device cable 100 is not positioned in the ear of the user (and no external force is applied on the cable 100), the hearing device cable 100 may be considered to be in the relaxed state. When the hearing device cable 100 is in the relaxed state, the body portion 120 may generally lie in a plane. Specifically, the tube centerline 121 along which the body portion 120 extends may be considered to remain in the plane between the first end region 122 and the second end region 124. For example, as shown in FIGS. 2A-2C, the tube centerline 121 of the body portion 120 extends along the x-y plane 109 (e.g., as shown in FIG. 2C). As a result, when the hearing device cable 100 is in the relaxed state, the body portion 120 only extends along two dimensions. In other words, the body portion 120 (e.g., the tube centerline 121) does not extend into the z-dimension. This “flat” shape (e.g., two-dimensional shape) of the body portion 120 may, e.g., simplify manufacturing and shipping, lessen the occurrence of cable damage when handling (e.g., when compared to cables that have a 90-degree bend), allow the body portion to be more rugged/robust and reduce the incidence of pinched/broken cables, reduce stress/strain on the cable by permitting gradual adaption to in-situ wear, reduce stress/strain when in storage or transportation, etc.

When the hearing device cable 100 is located and positioned in the ear of a user, the hearing device cable 100 may be considered to be in the deflected state. The first and second radial portion 132, 134 may adapt and comply to the ear of the user by deforming the body portion 120 to, e.g., increase comfort and fit to the user. As a result, when the hearing device cable 100 is in the deflected state, the body portion 120 (e.g., the tube centerline 121) may no longer only extend along the x-y plane (e.g., the body portion 120 may deflect along the z-dimension due to the anatomy of a human ear). The body portion 120 deflects with a minimal resistance (e.g., in length and orientation) such that the body portion 120 deforms as necessary to remain comfortable to the user, but the body portion 120 reverts back to a two-dimensional cable lying substantially in a plane (e.g., along tube centerline 121) when removed from the ear (e.g., the body portion 120 retains its original shape after deformation). In other words, the body portion 120 does not significantly deform after removal from the ear. Further, when the hearing device cable 100 is placed within a corresponding case or charger, the hearing device cable 100 may straighten out or revert to lying in a plane (e.g., due to interaction with the case or charger). As a result, the hearing device cable 100 may be transported or stored as a generally two-dimensional cable when not in use.



The shape of each of the first and second radial portions **132**, **134** may allow the body portion **120** to deform as needed in any direction to fit different sized ears (e.g., for an adult or a pediatric configuration). Specifically, the first radial portion **132** may be sized and shaped to conform to the pinna (e.g., above the ear) to enhance positioning of the device (e.g., the ear housing) behind the ear. The second radial portion **134** may be sized and shaped to extend into the ear canal (e.g., to the ear piece or bud) and extend towards an outer edge of the ear. Each of the first and second radial portions **132**, **134** may be sized to minimize the amount of material that extends outwards from the ear (e.g., to keep the body portion **120** tighter to the head, less protrusion from the ear).

Further, the first and second radial portions may be sized relative to one another to optimize the fit of the body portion **120** within the ear. For example, the radius of curvature **R1** of the first radial portion **132** may be greater than or equal to the radius of curvature **R2** of the second radial portion **134**. For example, the radius of curvature **R1** of the first radial portion **132** may be greater than or equal to 100% and/or less than or equal to 200% of the radius of curvature **R2** of the second radial portion **134**. Specifically, the radius of curvature **R1** of the first radial portion **132** may be at least 33% larger than the radius of curvature **R2** of the second radial portion **134**. In one or more embodiments, the radius of curvature **R1** of the first radial portion **132** may be about greater than or equal to 0.1 inches and/or less than or equal to 2.5 inches and the radius of curvature **R2** of the second radial portion **134** may be about greater than or equal to 0.1 inches and/or less than or equal to 2.5 inches. In other embodiments, the radius of curvature **R1** of the first radial portion **132** may be less than the radius of curvature **R2** of the second radial portion **134**.

The body portion **120** may be adapted or configured to deflect (e.g., when positioned in a human ear) such that a direct distance **110** between the first end region **122** and the second end region **124** increases or decreases (e.g., to fit various sized ears). The shape of the first and second radial portions **132**, **134** allow the body portion to deflect for any necessary configuration. For example, the radii of curvature **R1**, **R2** may be able to easily increase or decrease due to their curved shape. Further, the direct distance **110** between the first and second end regions **122**, **124** may be different when the hearing device cable **100** is in the relaxed state than when the hearing device cable **100** is in the deflected state. It is noted that while the direct distance **110** may change when the body portion **120** deflects, the length of the body portion **120** along the tube centerline **121** between the first and second end regions **122**, **124** will always remain constant. This constant internal length (as well as a constant inside diameter of a cable **100** that includes a passageway) between the first and second end regions **122**, **124** may permit a more accurate modeling of acoustic effects, which may have a much higher degree of accuracy and sound quality from any programming software.

The body portion **120** may be adapted or configured to fit within a human ear (e.g., either of the left or right ear) such that the first end region **122** is positioned above the ear and the second end region **124** is positioned within an ear canal. Additionally, the hearing device may include an ear interface **106** (e.g., an ear bud or coupled to an ear bud) coupled proximate the second end region **124** of the body portion **120** and a connector **108** (e.g., to connect a housing of a hearing device to the body portion **120**) coupled proximate the first end region **122** of the body portion **120**. In one or more embodiments, the ear interface **106** may be configured to fit

a variety of different sized ear buds (e.g., through barbs or bonding). In some embodiments, the body portion **120** may not include a connector **108** (e.g., proximate the first end region **122**), but rather, may include a permanent cross-pinned cable assembly.

Another illustrative embodiment of a hearing device cable **200** is shown in FIGS. **4-5**. Each of the features described with respect to FIGS. **2-3** also apply to the hearing device cable **200**. Likewise, each of the features described with respect to FIGS. **4-5** may apply to the hearing device cable **100**. The hearing device cable **200** (e.g., for a BTE device) may be a conduit that transports audio and may be internally shaped by a memory alloy wire (e.g., the superelastic wire **140** described below). For example, the hearing device cable **200** may include a body portion **220** (e.g., a tube) that extends along a tube centerline or curved axis between a first end region **222** and a second end region **224** (e.g., with the tube centerline of the hearing device cable **200** extending only within in a plane when in a relaxed state). Additionally, the body portion **220** may include a first radial portion **232** proximate the first end region **222** and a second radial portion **234** proximate the second end region **224**. The hearing device may also include an ear interface **206** (e.g., an ear bud) coupled proximate the second end region **224** of the body portion **220** and a connector **208** (e.g., to connect an ear piece to the body portion **220**) coupled proximate the first end region **222** of the body portion **220**. In some embodiments, the design of the body portion **220** may be adapted to a variety of device mounting strategies (e.g., ball and socket, barb fitting, threaded,  $\frac{1}{4}$  disconnects) without changing the aesthetics of the cable **200**.

As shown in FIG. **5A**, the body portion **220** may define a passageway **225** (e.g., for conducting processed sound) extending between the first end region **222** and the second end region **224**. Furthermore, the hearing device cable **200** may include a superelastic wire **140** (e.g., a nitinol wire) located within the passageway **225** and extending between a first wire end region **142** (e.g., proximate the first end region **222**) and a second wire end region **144** (e.g., proximate the second end region **224**). The superelastic wire **140** provides shape to the cable **200** from the inside-out rather than from the outside in (e.g., which would be the case for rigid molded or heat formed tubes). This may provide additional comfort and may help adapt to the body, while expanding the number of materials available to construct the hearing device cable **200** (e.g., because the multiple materials may be used to form the body portion **220**). Furthermore, the consistency of the outside diameter of the hearing device cable **200** from the first end region **220** to the second end region **222** may draw less attention to the design configuration.

The superelastic wire **140** may include any variety of materials that help define the shape of the body portion **220** and remain coupled therein. For example, the superelastic wire **140** may include nitinol. A nitinol memory wire may retain its shape, allowing usage of a soft flexible tubing for the hearing device cable **200** to, e.g., enhance comfort while overcoming the most common thin tube failure modes. The nitinol may minimally affect the acoustics passing through the passageway **225** of the body portion **220** (e.g., while permitting a wider selection of tube materials, wall sections, and diameters without sacrificing fit, comfort, or kink resistance). In one or more embodiments, the body portion **220** may be pinched by fingers during insertion or removal from the ear, and the body portion **220** may return to an un-kinked cross-section (e.g., due to the elastomeric nature of the superelastic wire **140** contained therein). In other words, because the body portion **220** may include a superelastic

wire **140** contained therein, the body portion **220** may provide a robust design that may not collapse or kink the body portion **220** or alter the shape of the superelastic wire **140**. Furthermore, the superelastic wire **140** may permit the body portion **220** to be cleaned with a variety of different methods. For example, the body portion **220** may be cleaned using boiling water without losing its shape or integrity because the superelastic wire **140** defines a deformation temperature greater than or equal to 500 degrees Fahrenheit, greater than or equal to 700 degrees Fahrenheit, greater than or equal to 900 degrees Fahrenheit, etc.

The first wire end region **142** may be coupled (e.g., to the body portion **220**) proximate the first end region **222** and the second wire end region **144** may be coupled (e.g., to the body portion **220** or the ear interface **206**) proximate the second end region **224** (e.g., with the ear interface **206**). In one or more embodiments, the second wire end region **144** may be folded or hooked proximate the ear interface **206** (e.g., as shown in enlarged view FIG. **5B**). The superelastic wire **140** may be folded or hooked to prevent the terminal end of the super elastic wire **140** from extending outward from the body portion **220** and potentially creating a point that could be exposed to the ear. As a result, the second wire end region **144** may fold back towards the passageway **225** to create a smoother end. Further, the ear interface **206** may define a chamfer or taper proximate the passageway **225** such that the folded portion of the superelastic wire **140** may be prevented from pushing through the ear interface **206** and into a user's ear (e.g., because the passageway **225** at the ear interface **206** may be narrower than the width of the superelastic wire **140** at the fold).

Illustrative embodiments are described and reference has been made to possible variations of the same. These and other variations, combinations, and modifications will be apparent to those skilled in the art, and it should be understood that the claims are not limited to the illustrative embodiments set forth herein.

What is claimed is:

**1.** A hearing device cable comprising:

a body portion extending between a first end region and a second end region, wherein the body portion comprises a first radial portion proximate the first end region and a second radial portion proximate the second end region, wherein the cable is configurable in a relaxed state and a deflected state, wherein the body portion deforms to comply with an ear of a user when the cable is in the deflected state and the body portion reverts back to the relaxed state when removed from the ear of the user,

wherein the first radial portion defines a radius of curvature that is greater than or equal to a radius of curvature defined by the second radial portion.

**2.** The cable of claim **1**, wherein the radius of curvature of the first radial portion is greater than or equal to 100% and less than or equal to 200% of the radius of curvature of the second radial portion.

**3.** The cable of claim **1**, wherein the body portion defines an S-shape such that the first radial portion extends along an arc that curves in a direction opposite an arc along which the second radial portion extends.

**4.** The cable of claim **1**, wherein the body portion comprises one or more conductive wires and Kevlar.

**5.** The cable of claim **1**, wherein the body portion is adapted to fit within a human ear such that the first end region is positioned above the human ear and the second end region is positioned within an ear canal of the human ear.

**6.** The cable of claim **1**, wherein the body portion comprises a UV resistant material.

**7.** The cable of claim **1**, wherein a direct distance between the first end region and the second end region is different in the relaxed state than the deflected state.

**8.** The cable of claim **1**, wherein the body portion defines a passageway extending between the first end region and the second end region.

**9.** The cable of claim **8**, further comprising a superelastic wire within the passageway extending between the first end region and the second end region.

\* \* \* \* \*