



US011490685B2

(12) **United States Patent**
Meschter et al.

(10) **Patent No.:** **US 11,490,685 B2**
(45) **Date of Patent:** ***Nov. 8, 2022**

(54) **SUPPORT MEMBERS WITH VARIABLE VISCOSITY FLUID FOR FOOTWEAR**

(71) Applicant: **NIKE, Inc.**, Beaverton, OR (US)

(72) Inventors: **James C. Meschter**, Portland, OR (US); **Mike A Chamblin**, Portland, OR (US); **Andrew A. Owings**, Portland, OR (US)

(73) Assignee: **NIKE, Inc.**, Beaverton, OR (US)

(*) Notice: Subject to any disclaimer, the term of this patent is extended or adjusted under 35 U.S.C. 154(b) by 56 days.

This patent is subject to a terminal disclaimer.

(21) Appl. No.: **17/098,595**

(22) Filed: **Nov. 16, 2020**

(65) **Prior Publication Data**

US 2021/0298418 A1 Sep. 30, 2021

Related U.S. Application Data

(63) Continuation of application No. 16/051,656, filed on Aug. 1, 2018, now Pat. No. 10,834,997, which is a continuation of application No. 14/926,785, filed on Oct. 29, 2015, now Pat. No. 10,058,146, which is a continuation of application No. 13/784,952, filed on Mar. 5, 2013, now Pat. No. 9,198,478.

(51) **Int. Cl.**
A43B 13/18 (2006.01)
A43B 13/20 (2006.01)
(Continued)

(52) **U.S. Cl.**
CPC *A43B 13/189* (2013.01); *A43B 1/0054* (2013.01); *A43B 3/38* (2022.01);
(Continued)

(58) **Field of Classification Search**

CPC *A43B 1/0054*; *A43B 13/18*; *A43B 13/181*; *A43B 13/185*; *A43B 13/189*; *A43B 13/20*;

(Continued)

(56) **References Cited**

U.S. PATENT DOCUMENTS

3,511,583 A 5/1970 Brown
4,053,952 A 10/1977 Goldstein
(Continued)

FOREIGN PATENT DOCUMENTS

CN 1842283 A 10/2006
CN 101291601 A 10/2008
(Continued)

OTHER PUBLICATIONS

“European Application Serial No. 21202283.4, Response filed Feb. 9, 2022 to Notification to File Statement of Subject Matter to be Searched EPC dated Jan. 11, 2022”, 12 pgs.

(Continued)

Primary Examiner — Megan E Lynch

(74) *Attorney, Agent, or Firm* — Schwegman Lundberg & Woessner, P.A.

(57) **ABSTRACT**

An article of footwear including an adaptive support system includes a plurality of support members. Each support member includes an outer chamber and an inner chamber, the inner chamber being filled with a magnetorheological fluid. An electromagnet is disposed adjacent to the inner chamber and can be used to vary the viscosity of the magnetorheological fluid.

19 Claims, 9 Drawing Sheets

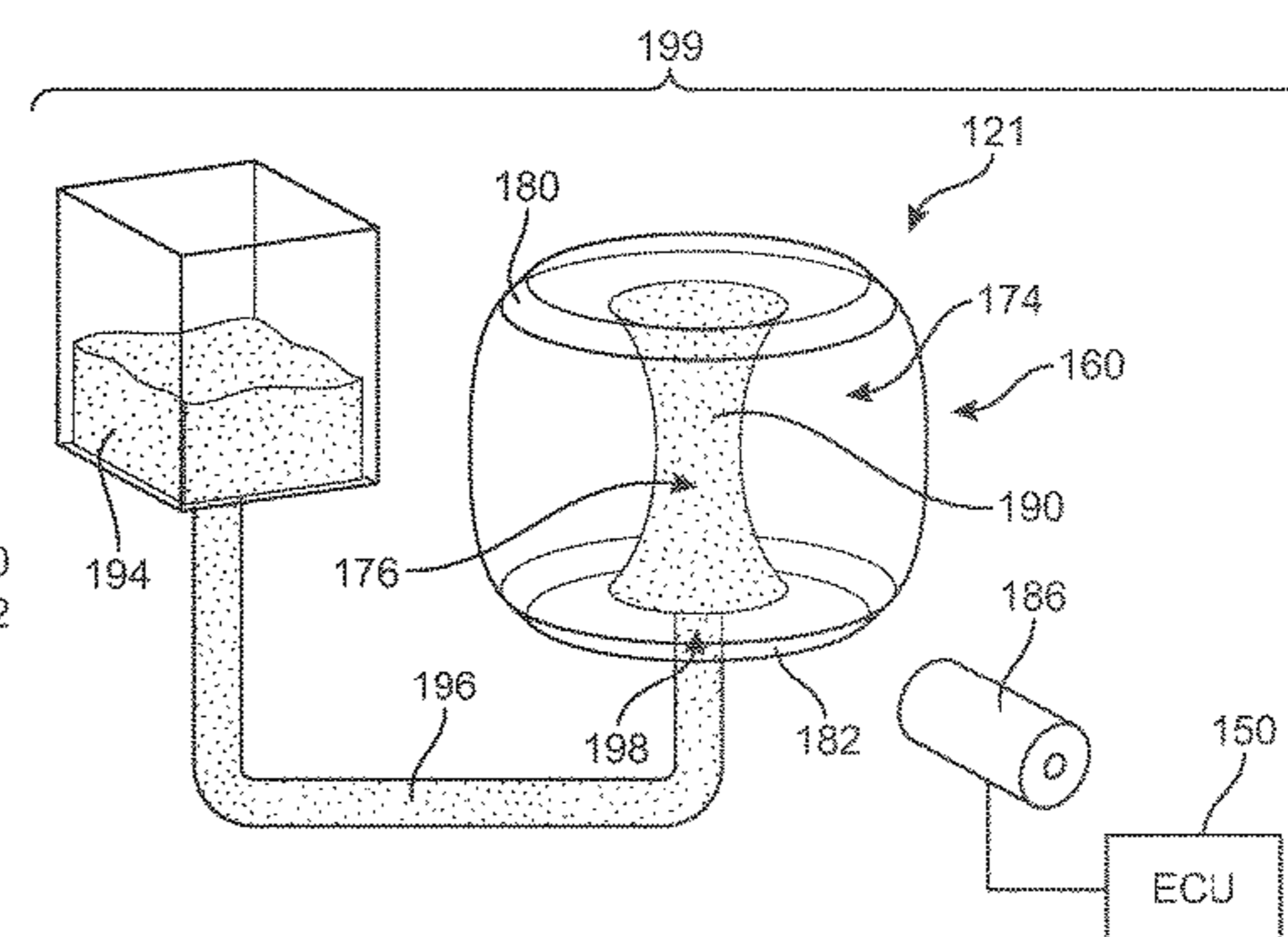
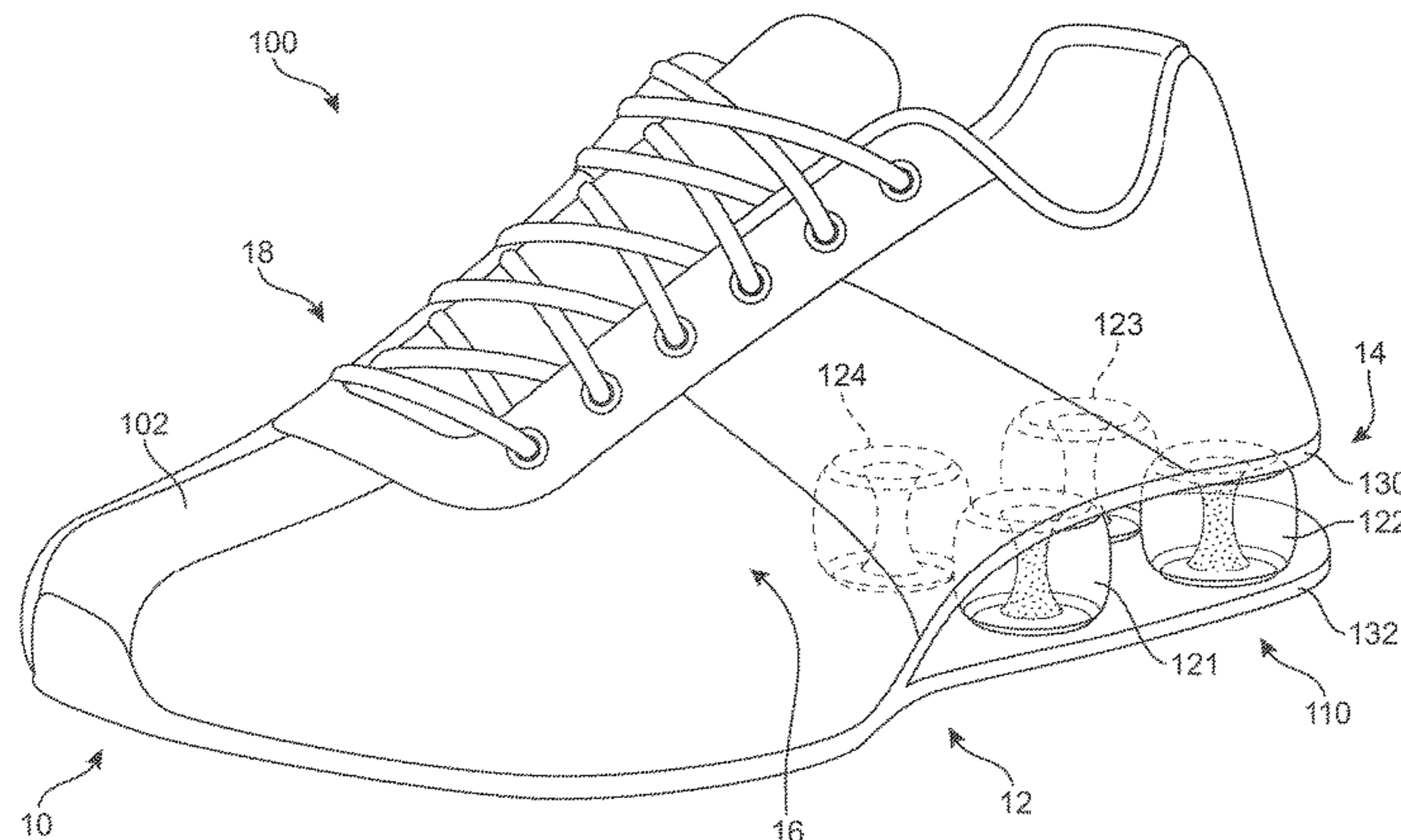

- (51) **Int. Cl.**
A43B 1/00 (2006.01)
A43B 3/38 (2022.01)
- (52) **U.S. Cl.**
 CPC *A43B 13/188* (2013.01); *A43B 13/20*
 (2013.01); *A43B 13/206* (2013.01)
- (58) **Field of Classification Search**
 CPC A43B 13/206; A43B 21/32; A43B 21/265;
 A43B 17/026; A43B 17/03
 See application file for complete search history.

| | | |
|----|------------------|---------|
| JP | H10327906 A | 12/1998 |
| JP | 11113605 A | 4/1999 |
| JP | H11113605 A | 4/1999 |
| JP | 2009535157 A | 10/2009 |
| JP | 2016508837 A | 3/2016 |
| JP | 6322657 B2 | 4/2018 |
| JP | 2018074434 A | 5/2018 |
| JP | 2018134450 A | 8/2018 |
| JP | 6398030 B2 | 9/2018 |
| JP | 2018202197 A | 12/2018 |
| JP | 6739484 B2 | 7/2020 |
| WO | WO-2007125148 A1 | 11/2007 |
| WO | WO-2008150793 A2 | 12/2008 |
| WO | WO-2014138020 A1 | 9/2014 |

(56) **References Cited**

U.S. PATENT DOCUMENTS

| | | |
|-------------------|---------|--------------------------------------|
| 4,471,538 A | 9/1984 | Pomeranz et al. |
| 4,928,125 A | 5/1990 | Iino |
| 5,267,633 A | 12/1993 | Endo et al. |
| 5,316,261 A | 5/1994 | Stoner |
| 5,794,361 A | 8/1998 | Sadler |
| 6,568,102 B1 | 5/2003 | Healy et al. |
| 7,219,449 B1 | 5/2007 | Hoffberg et al. |
| 7,506,460 B2 | 3/2009 | Dibenedetto et al. |
| 7,566,209 B2 | 7/2009 | Estes et al. |
| 9,198,478 B2 * | 12/2015 | Meschter A43B 13/20 |
| 10,058,146 B2 | 8/2018 | Meschter et al. |
| 10,834,997 B2 | 11/2020 | Meschter et al. |
| 2003/0120353 A1 * | 6/2003 | Christensen A61F 2/80 36/37 |
| 2004/0154190 A1 | 8/2004 | Munster |
| 2004/0177531 A1 | 9/2004 | Dibenedetto et al. |
| 2004/0237346 A1 * | 12/2004 | Rudy F16F 9/0409 36/71 |
| 2005/0172515 A1 | 8/2005 | Ungari |
| 2006/0248749 A1 | 11/2006 | Ellis |
| 2006/0248750 A1 * | 11/2006 | Rosenberg A43B 1/0054 36/29 |
| 2007/0000154 A1 | 1/2007 | Dibenedetto et al. |
| 2007/0011920 A1 | 1/2007 | Dibenedetto et al. |
| 2007/0260421 A1 | 11/2007 | Berner, Jr. et al. |
| 2008/0016718 A1 | 1/2008 | Aveni et al. |
| 2008/0016719 A1 | 1/2008 | Aveni et al. |
| 2008/0016720 A1 | 1/2008 | Aveni et al. |
| 2008/0083140 A1 * | 4/2008 | Ellis A43B 7/1435 36/114 |
| 2009/0100705 A1 * | 4/2009 | Cook A43B 13/20 36/28 |
| 2009/0158622 A1 | 6/2009 | Cook et al. |
| 2009/0183387 A1 | 7/2009 | Ellis |
| 2010/0037482 A1 | 2/2010 | Litchfield et al. |
| 2010/0107444 A1 | 5/2010 | Aveni |
| 2010/0199519 A1 | 8/2010 | Battlogg |
| 2010/0252117 A1 | 10/2010 | Pattekar et al. |
| 2011/0131833 A1 | 6/2011 | Cook et al. |
| 2011/0175744 A1 | 7/2011 | Englert et al. |
| 2012/0234111 A1 | 9/2012 | Molyneux et al. |
| 2013/0167402 A1 | 7/2013 | Christensen |
| 2013/0278435 A1 | 10/2013 | Ellis |
| 2014/0250875 A1 | 9/2014 | Ignatchenko et al. |
| 2014/0259749 A1 | 9/2014 | Taylor et al. |
| 2016/0044993 A1 | 2/2016 | Meschter et al. |
| 2018/0338576 A1 | 11/2018 | Meschter et al. |

FOREIGN PATENT DOCUMENTS

| | | |
|----|-------------|---------|
| CN | 101842028 A | 9/2010 |
| CN | 102202534 A | 9/2011 |
| CN | 105163619 A | 12/2015 |
| CN | 105163619 B | 4/2017 |
| DE | 19725685 A1 | 12/1998 |
| EP | 2964047 B1 | 12/2018 |
| EP | 3473125 | 10/2021 |
| JP | 01169185 A | 7/1989 |
| JP | 02026380 A | 1/1990 |
| JP | H04262135 A | 9/1992 |
| JP | 10327906 A | 12/1998 |

OTHER PUBLICATIONS

“European Application Serial No. 21202283.4, Extended European Search Report dated Feb. 18, 2022”, 9 pgs.

“U.S. Appl. No. 13/784,952, Examiner Interview Summary dated May 7, 2015”, 3 pgs.

“U.S. Appl. No. 13/784,952, Non Final Office Action dated Mar. 12, 2015”, 14 pgs.

“U.S. Appl. No. 13/784,952, Notice of Allowance dated Jul. 30, 2015”, 12 pgs.

“U.S. Appl. No. 13/784,952, Response filed Jun. 11, 2015 to Non Final Office Action dated Mar. 12, 2015”, 13 pgs.

“U.S. Appl. No. 14/926,785, Examiner Interview Summary dated Feb. 2, 2018”, 2 pgs.

“U.S. Appl. No. 14/926,785, Non Final Office Action dated Sep. 26, 2017”, 16 pgs.

“U.S. Appl. No. 14/926,785, Notice of Allowance dated Apr. 26, 2018”, 5 pgs.

“U.S. Appl. No. 14/926,785, Response filed Feb. 26, 2018 to Non Final Office Action dated Sep. 26, 2017”, 7 pgs.

“U.S. Appl. No. 16/051,656, Corrected Notice of Allowability dated Oct. 15, 2020”, 2 pgs.

“U.S. Appl. No. 16/051,656, Examiner Interview Summary dated May 5, 2020”, 3 pgs.

“U.S. Appl. No. 16/051,656, Non Final Office Action dated Apr. 17, 2020”, 16 pgs.

“U.S. Appl. No. 16/051,656, Notice of Allowance dated Jul. 7, 2020”, 5 pgs.

“U.S. Appl. No. 16/051,656, Response filed May 5, 2020 to Non Final Office Action dated Apr. 17, 2020”, 10 pgs.

“Chinese Application Serial No. 201480024586.3, Office Action dated Jun. 22, 2016”, W/English Translation, 9 pgs.

“Chinese Application Serial No. 201480024586.3, Response filed Nov. 7, 2016 to Office Action dated Jun. 22, 2016”, with English translation of claims, 31 pgs.

“Chinese Application Serial No. 201480024586.3, Voluntary Amendment filed Mar. 25, 2016”, English Translation of Detailed Observation filed Mar. 25, 2016, 28 pgs.

“European Application Serial No. 14721565.1, Communication Pursuant to Article 94(3) dated Jul. 17, 2017”, 4 pgs.

“European Application Serial No. 14721565.1, Response filed Mar. 8, 2016 to Communication pursuant to Rules 161(1) and 162 EPC dated Oct. 13, 2015”, 17 pgs.

“European Application Serial No. 14721565.1, Response filed Nov. 2, 2017 to Communication Pursuant to Article 94(3) dated Jul. 17, 2017”, 8 pgs.

“European Application Serial No. 18211211.0, Communication Pursuant to Article 94(3) EPC dated Jul. 27, 2020”, 5 pgs.

“European Application Serial No. 18211211.0, Communication Pursuant to Article 94(3) EPC dated Dec. 20, 2019”, 6 pgs.

“European Application Serial No. 18211211.0, Extended European Search Report dated Mar. 27, 2019”, 8 pgs.

“European Application Serial No. 18211211.0, Response filed Jun. 17, 2020 to Communication Pursuant to Article 94(3) EPC dated Dec. 20, 2019”, 7 pgs.

“European Application Serial No. 18211211.0, Response filed Oct. 24, 2019 to Extended European Search Report dated Mar. 27, 2019”, 20 pgs.

(56)

References Cited

OTHER PUBLICATIONS

“International Application Serial No. PCT/US2014/020212, International Preliminary Report on Patentability dated Sep. 17, 2015”, 10 pgs.

“International Application Serial No. PCT/US2014/020212, International Search Report dated Jul. 7, 2014”, 5 pgs.

“International Application Serial No. PCT/US2014/020212, Written Opinion dated Jul. 7, 2014”, 8 pgs.

“Japanese Application Serial No. 2015-561529, Office Action dated Sep. 6, 2017”, With English Translation, 9 pgs.

“Japanese Application Serial No. 2015-561529, Response filed Jan. 26, 2018 to Office Action dated Sep. 6, 2017”, w/ English claims, 9 pgs.

“Japanese Application Serial No. 2015-561529, Voluntary Amendment filed Jul. 27, 2016”, 7 pgs.

“Japanese Application Serial No. 2018-164201, Notification of Reasons for Rejection dated Nov. 28, 2019”, W/English Translation, 11 pgs.

“Japanese Application Serial No. 2018-164201, Response filed Apr. 28, 2020 to Notification of Reasons for Rejection dated Nov. 28, 2019”, w/English Claims, 11 pgs.

“European Application Serial No. 18211211.0, Response filed Feb. 4, 2021 to Communication Pursuant to Article 94(3) EPC dated Jul. 27, 2020”, 7 pgs.

* cited by examiner

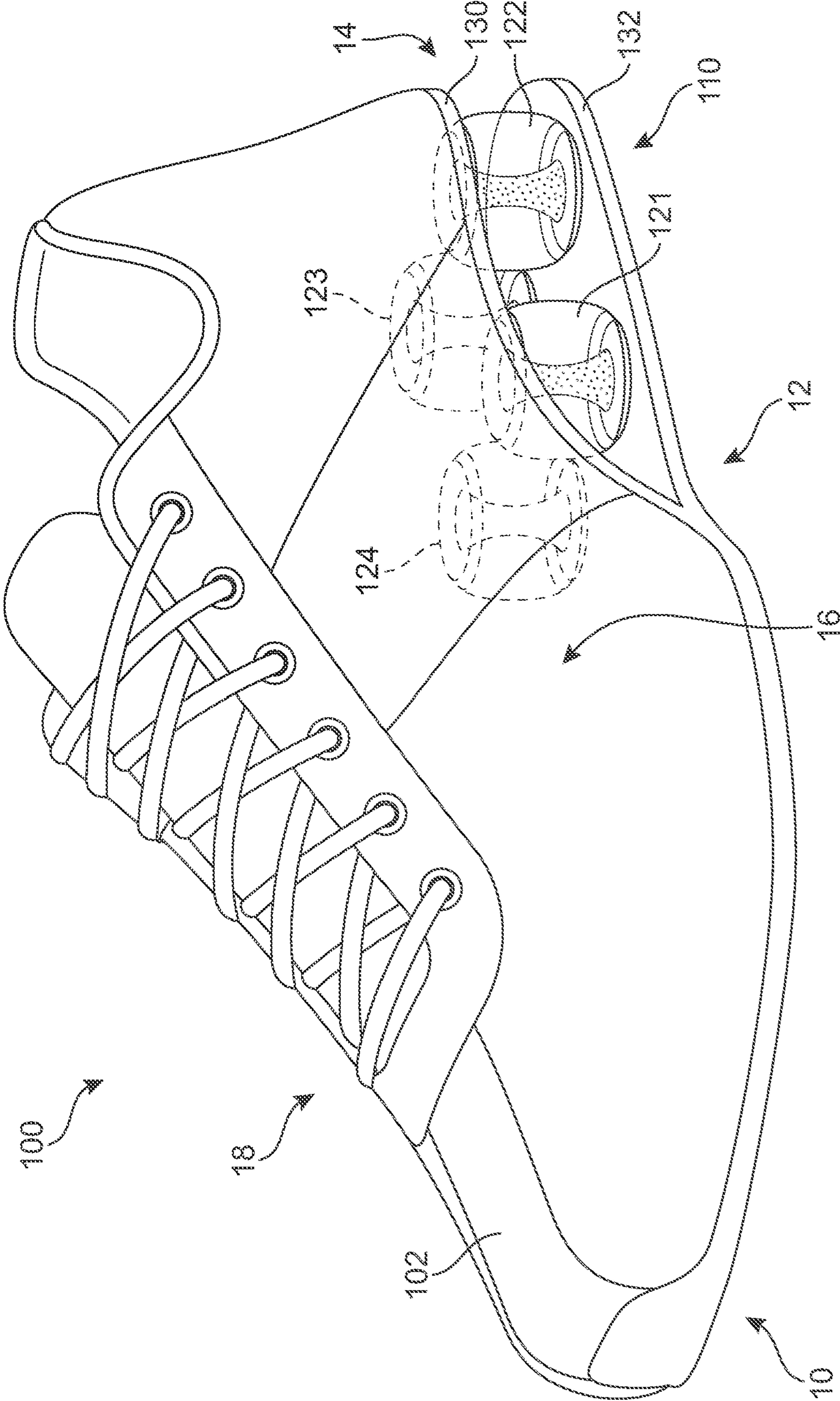

FIG. 1

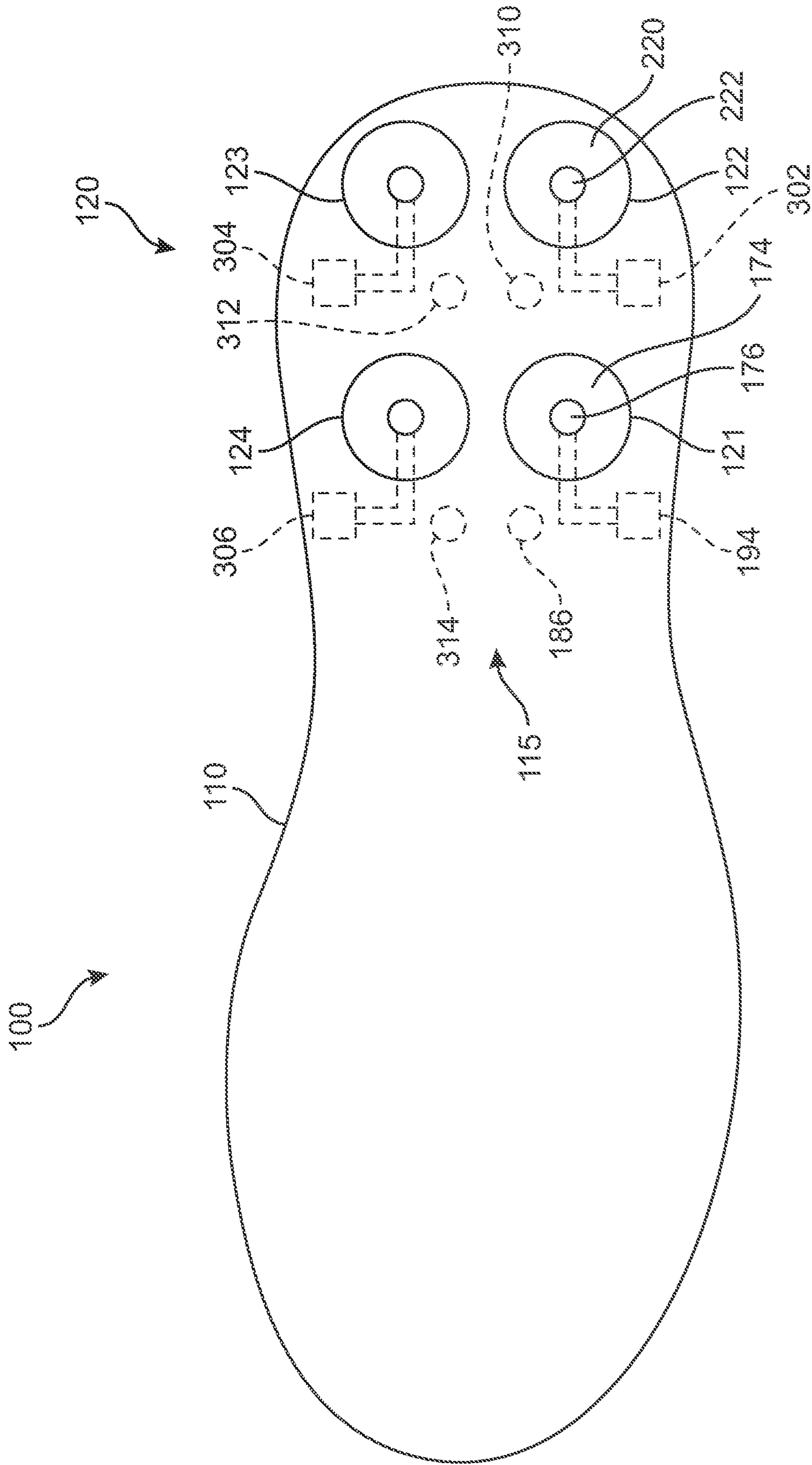

FIG. 2

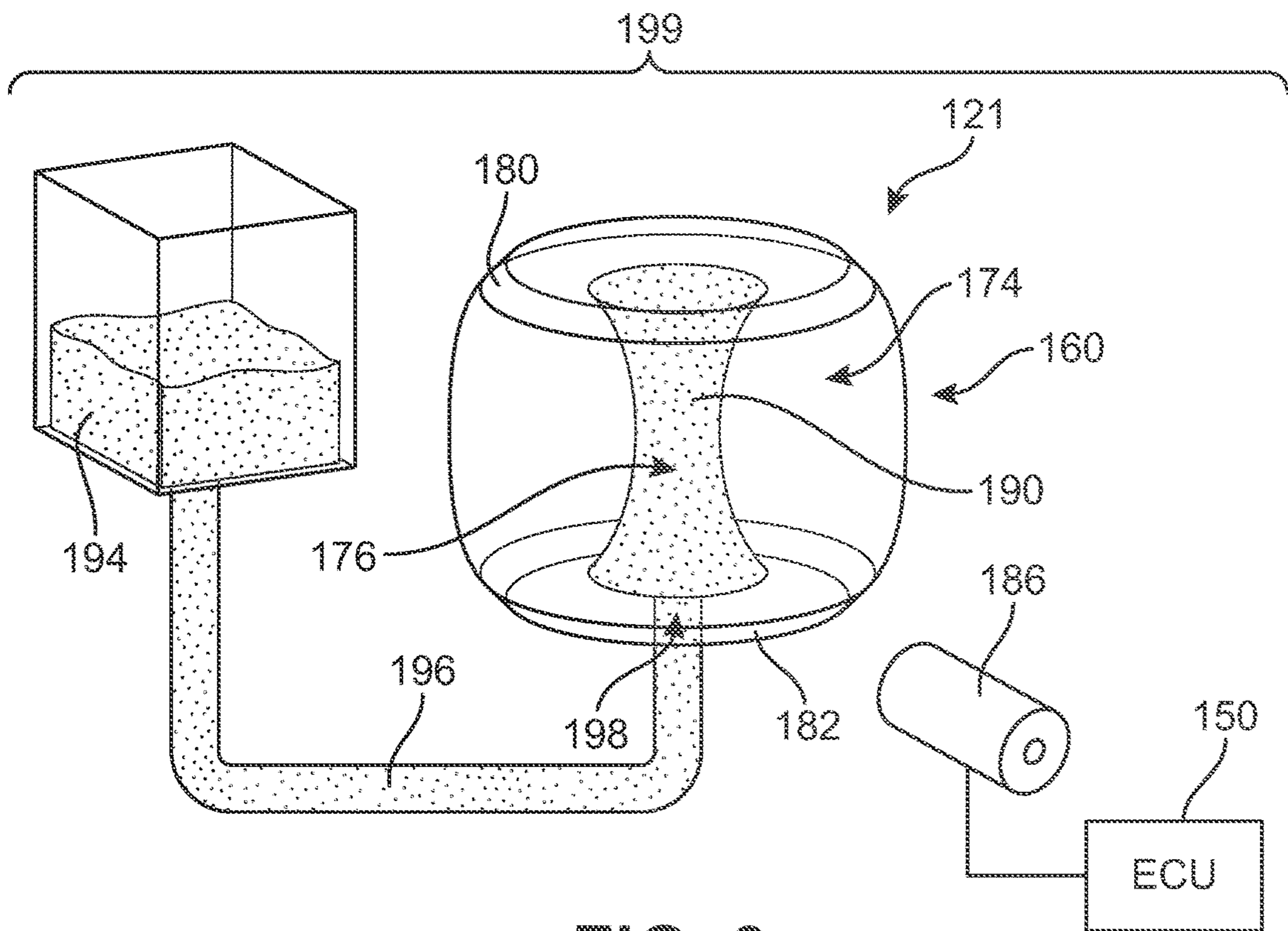

FIG. 3

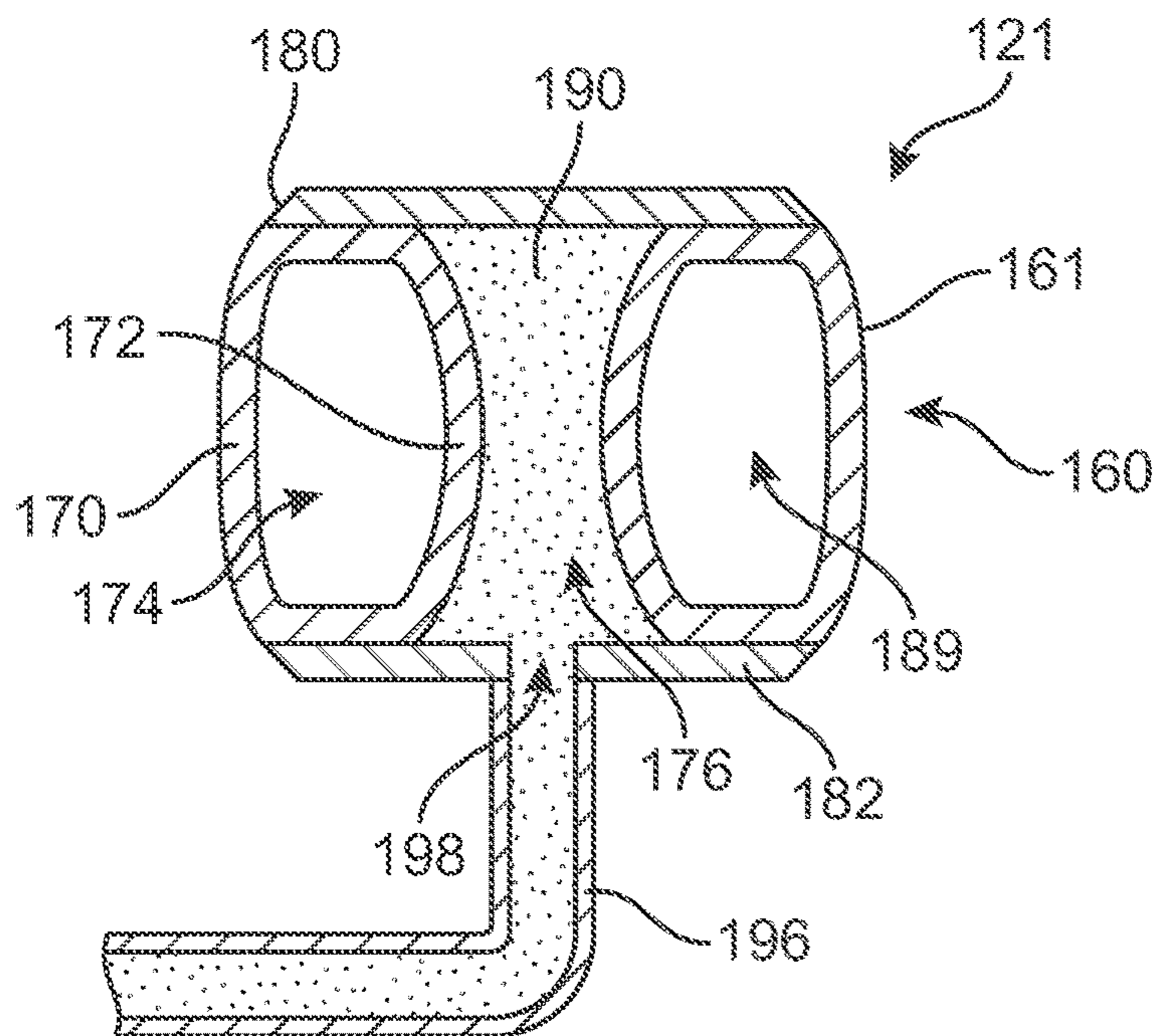

FIG. 4

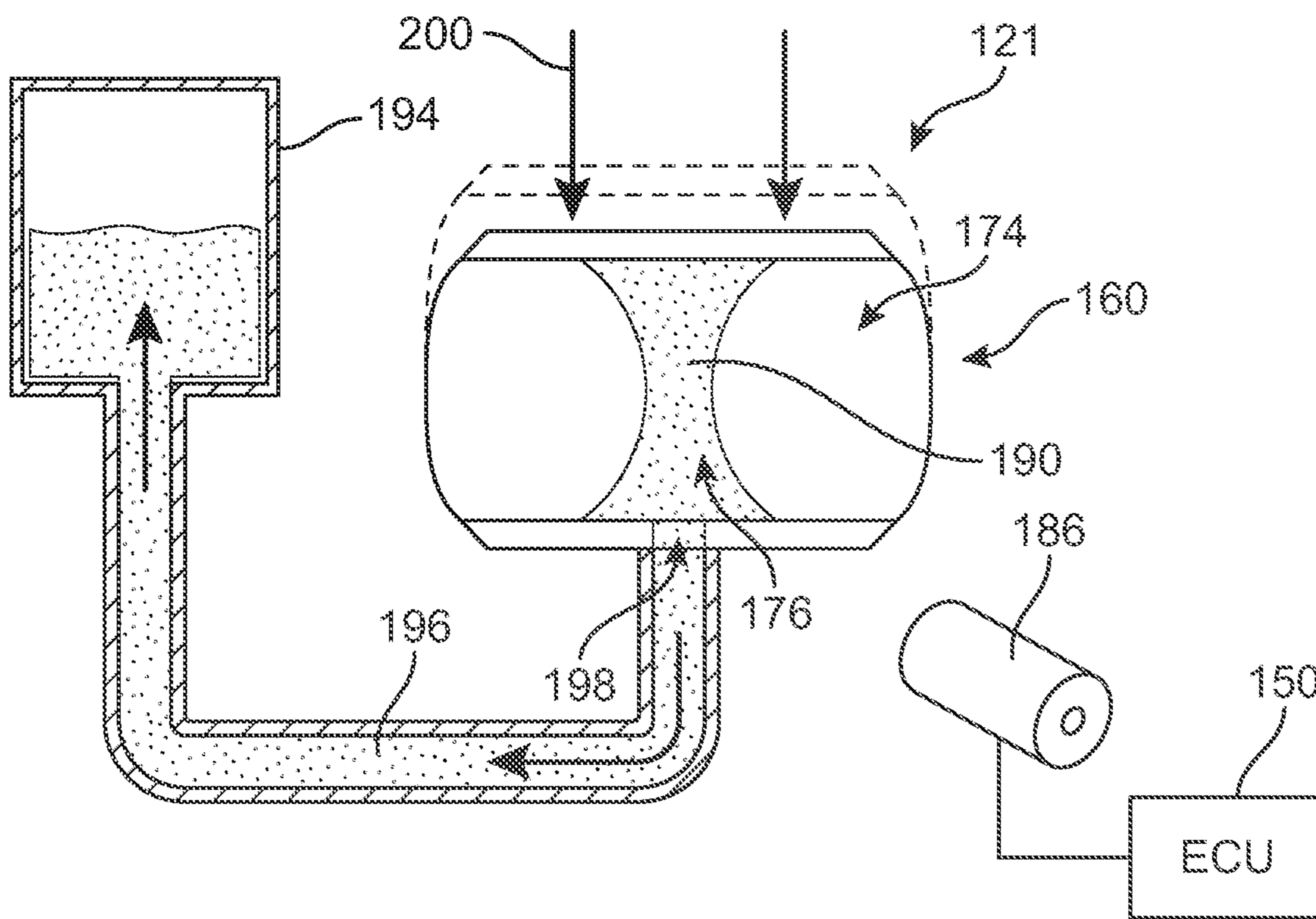

FIG. 5

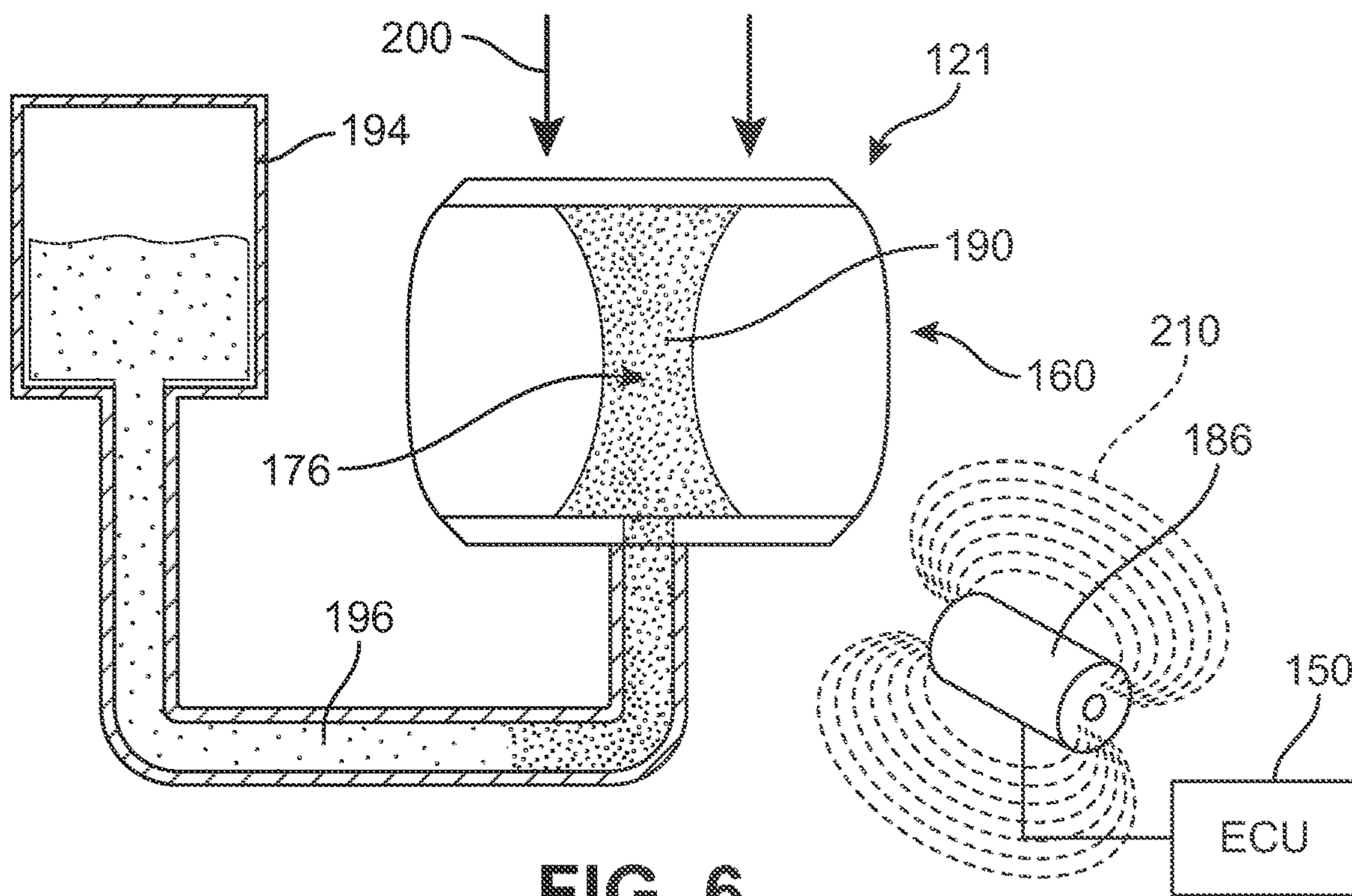

FIG. 6

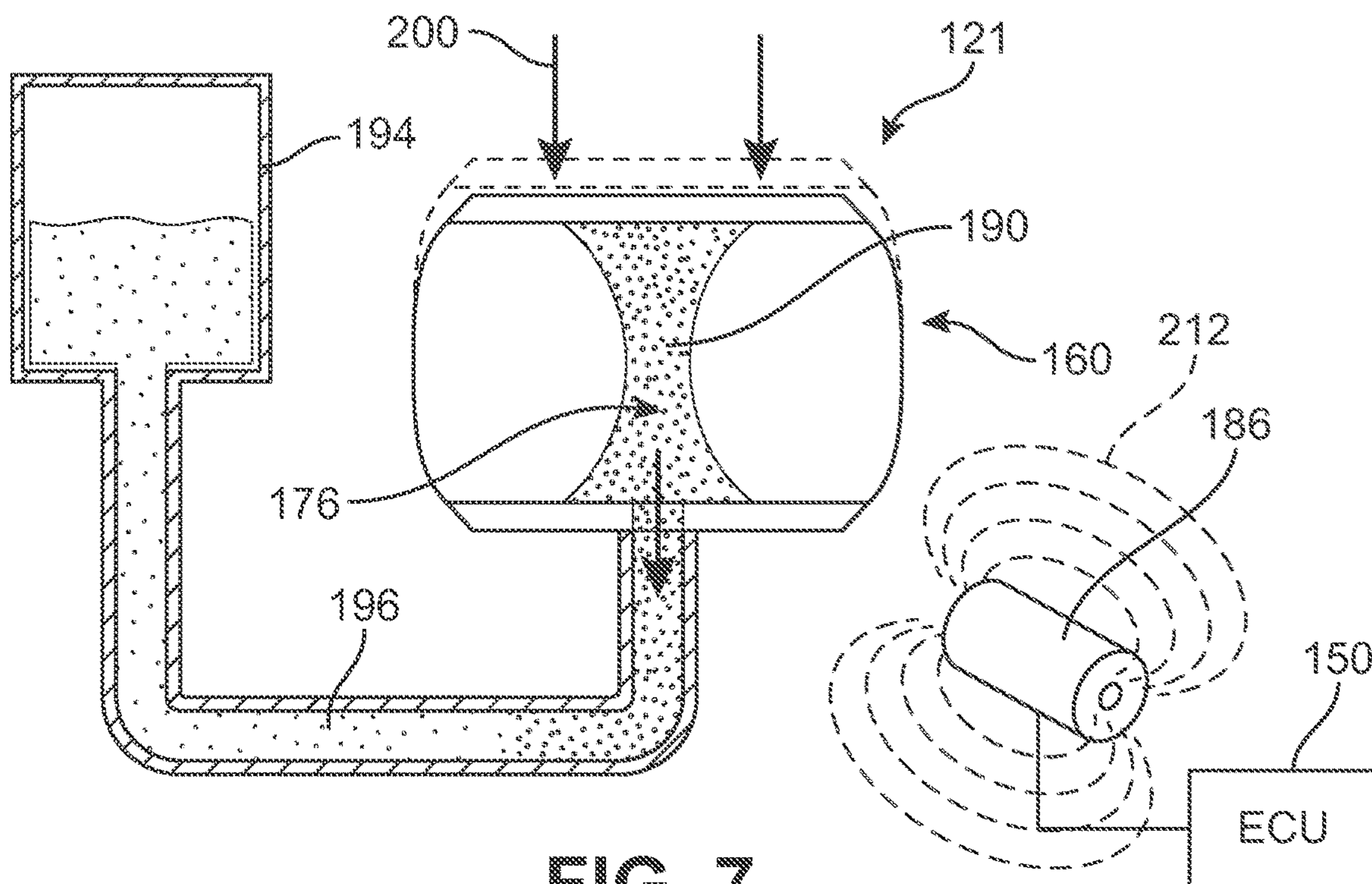

FIG. 7

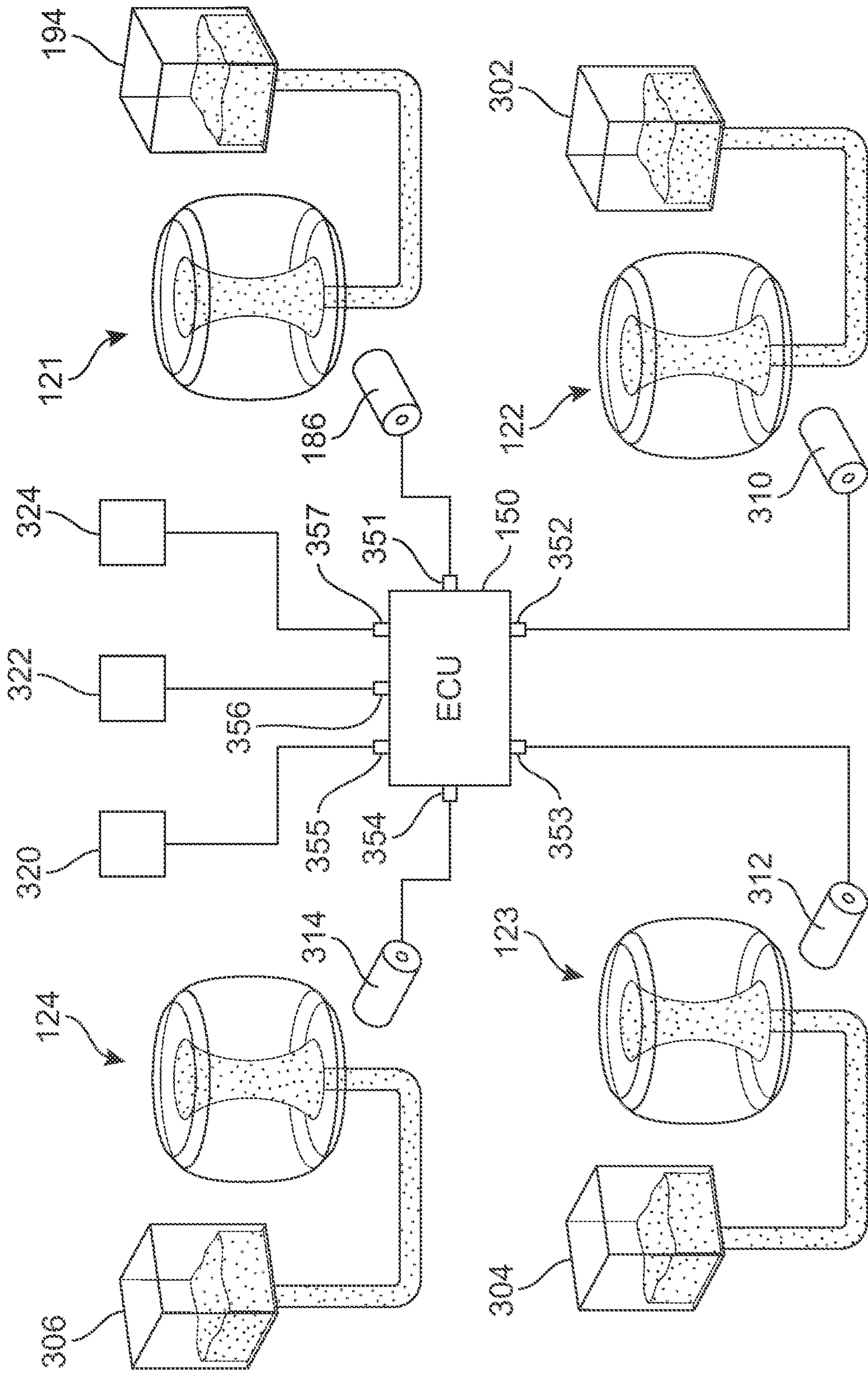

FIG. 8

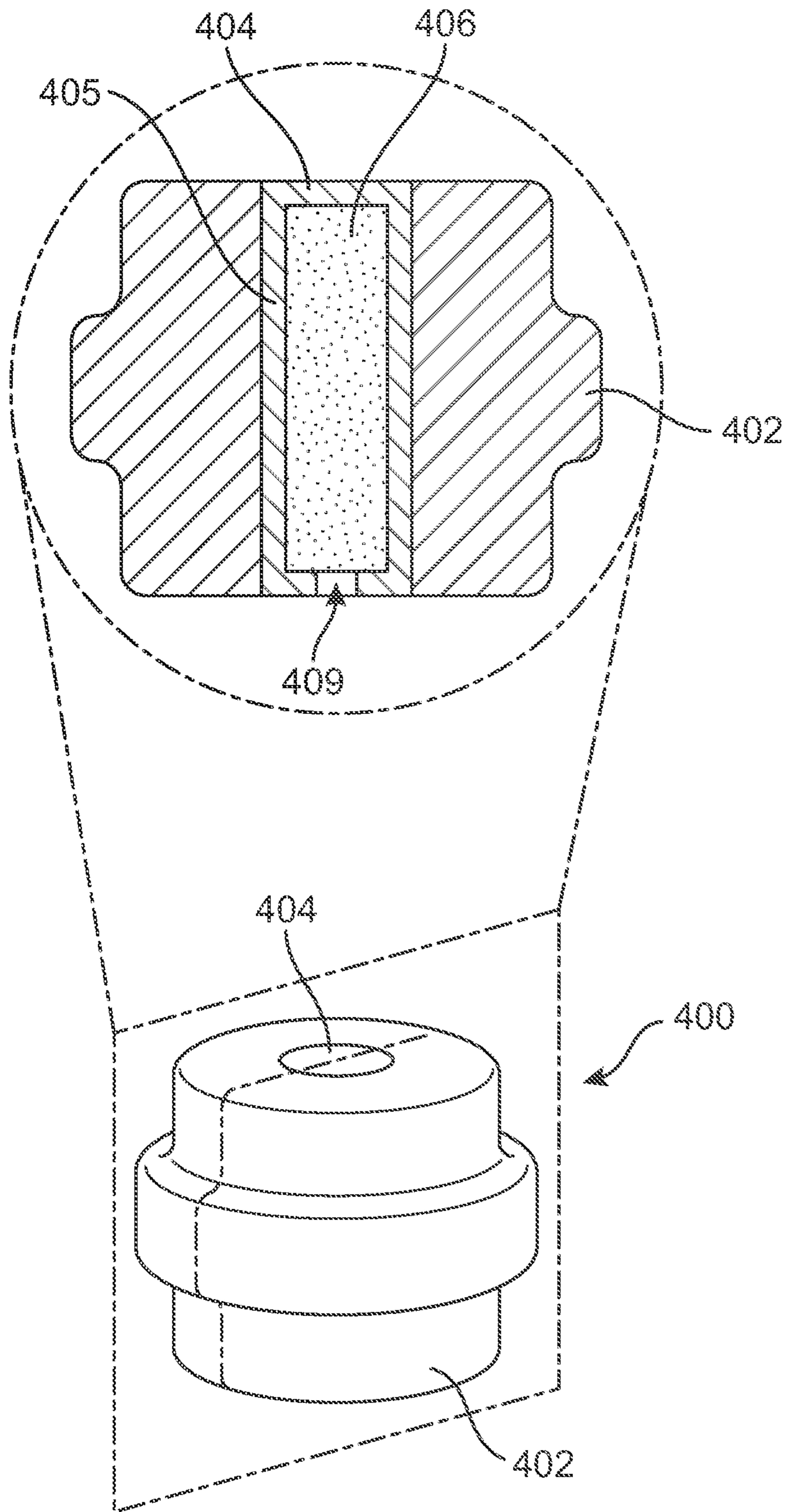

FIG. 9

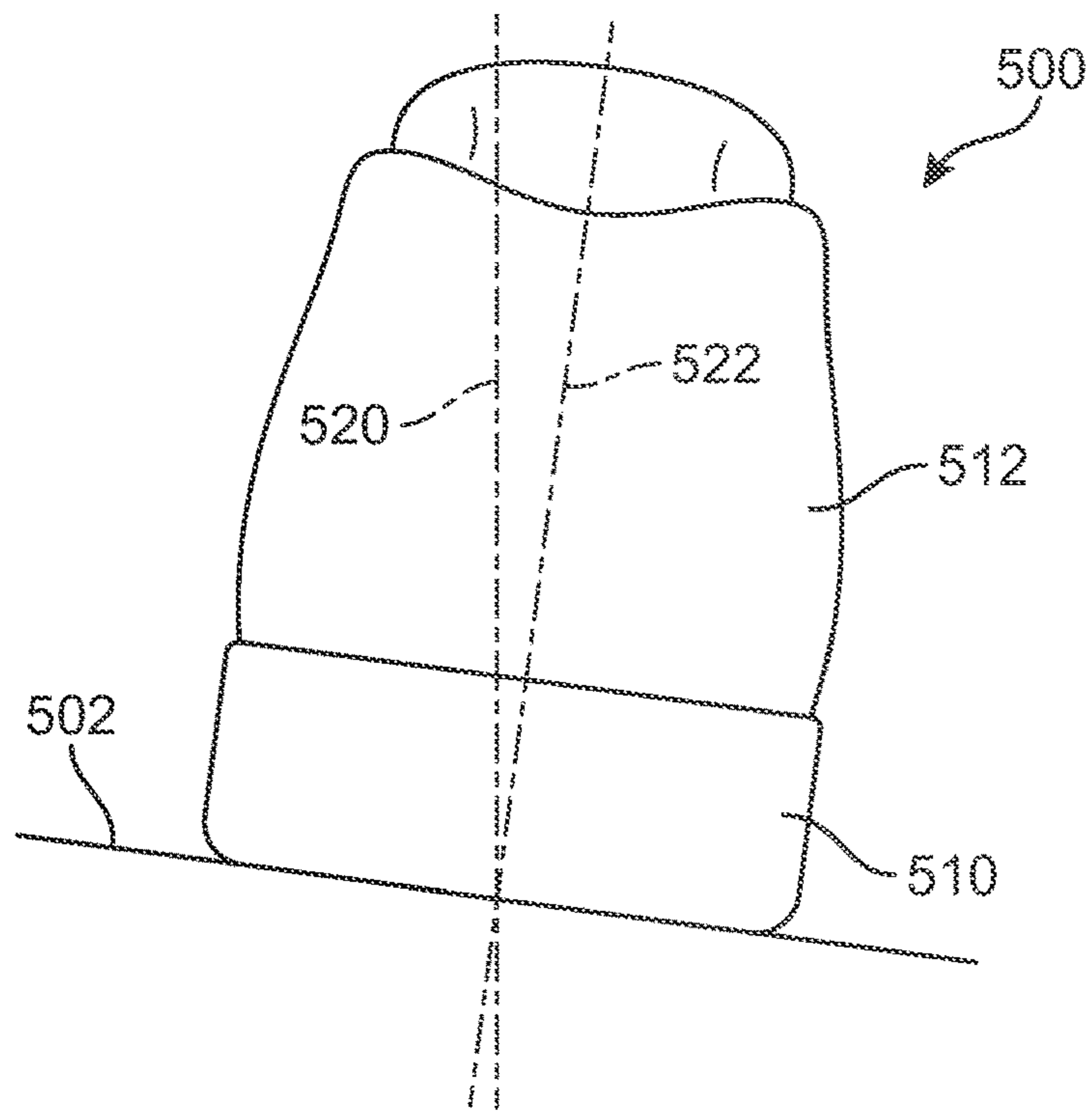

FIG. 10

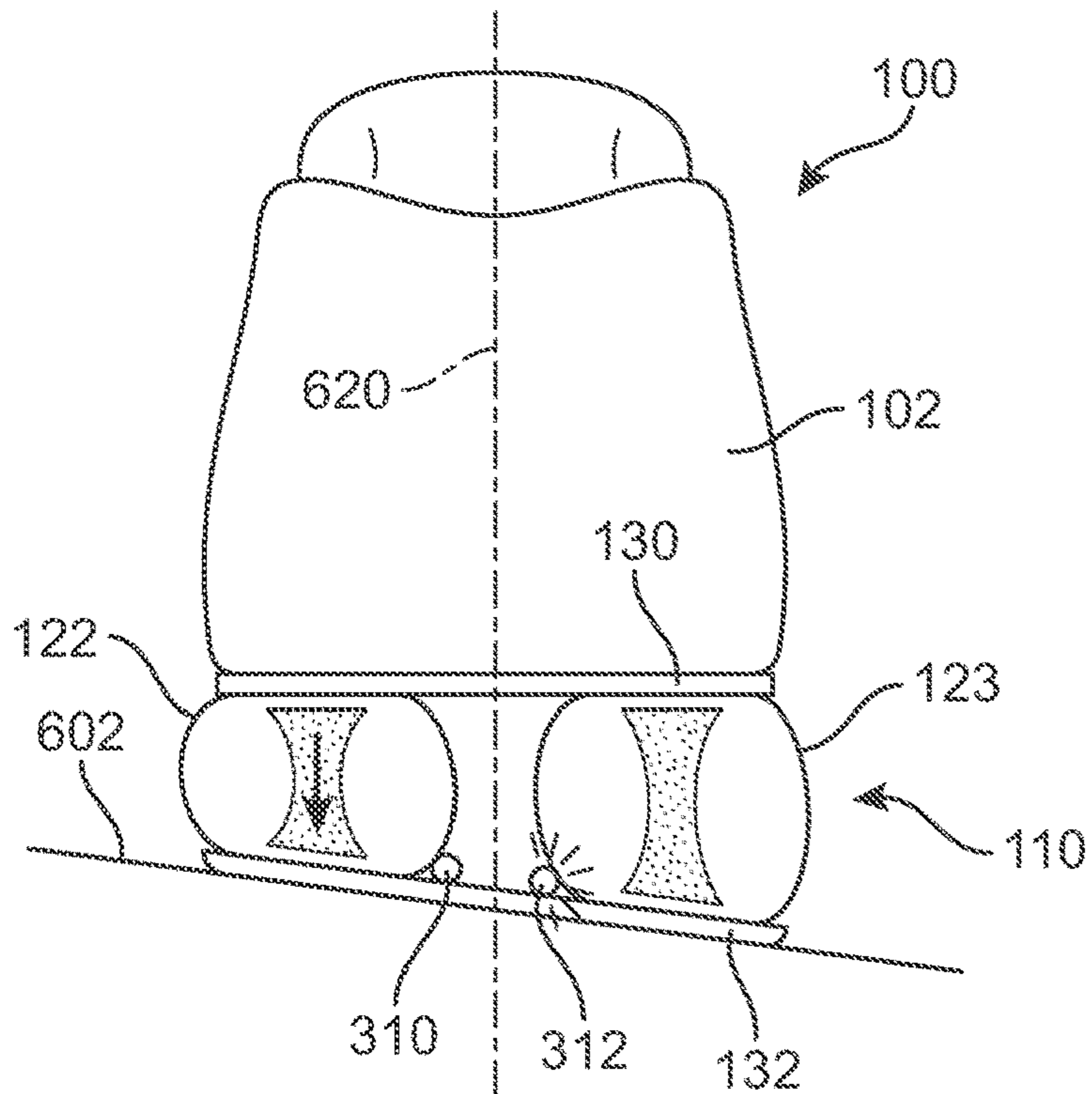

FIG. 11

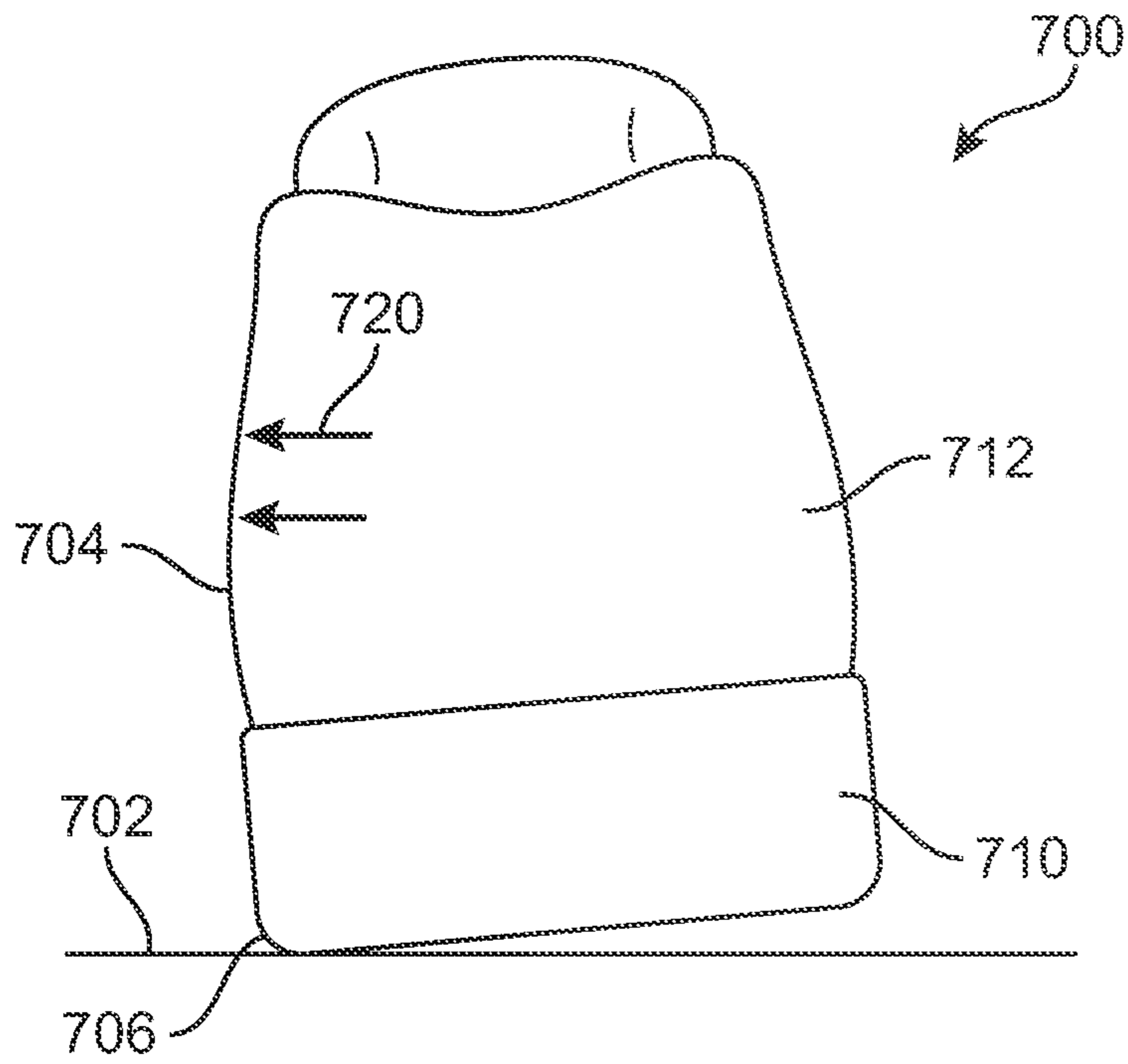

FIG. 12

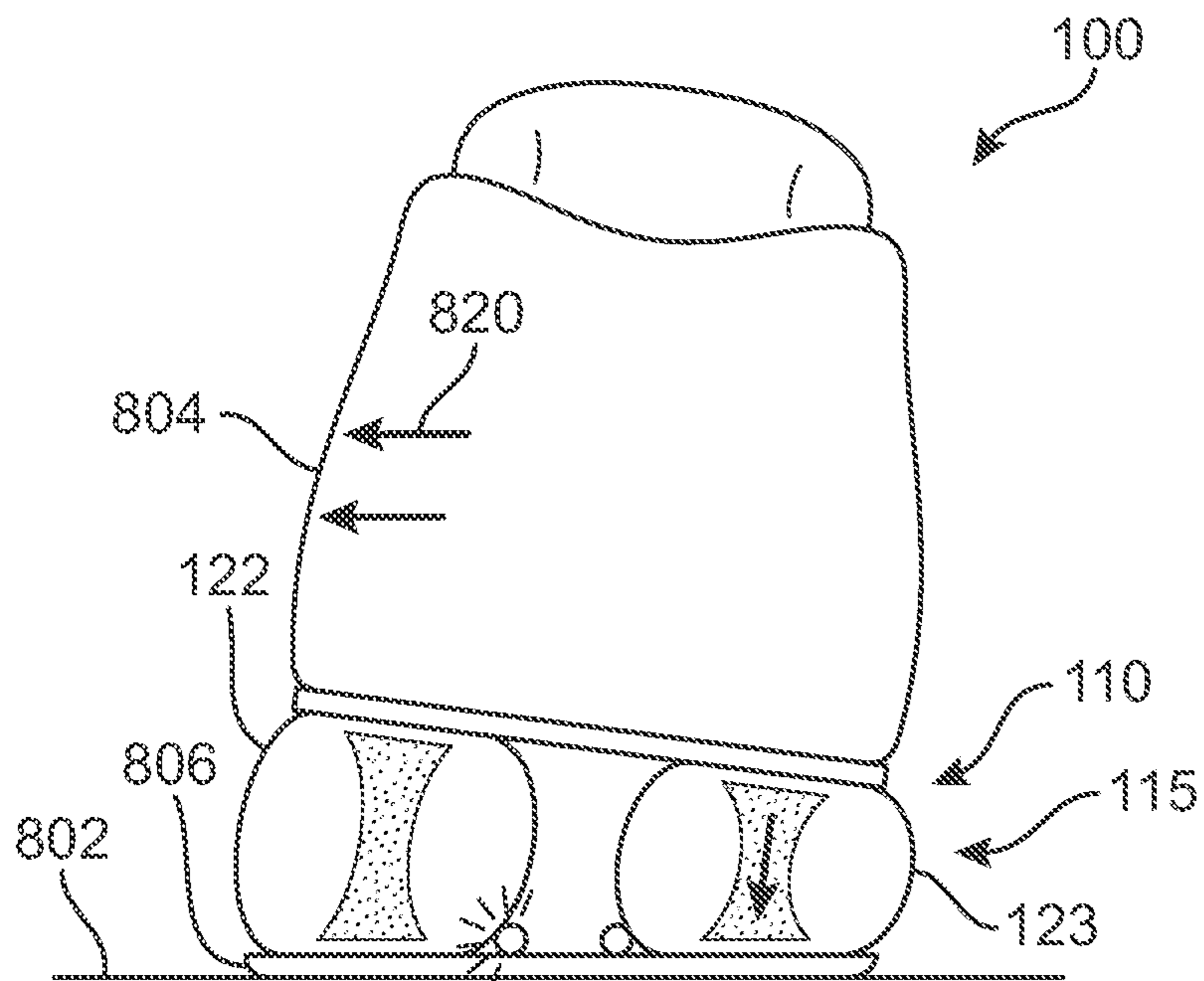

FIG. 13

1

SUPPORT MEMBERS WITH VARIABLE VISCOSITY FLUID FOR FOOTWEAR

CROSS-REFERENCE TO RELATED APPLICATIONS

This application is a divisional of Meschter, U.S. Patent Application Publication No. 2014/0250726, published on Sep. 11, 2014 and entitled "Support Members with Variable Viscosity Fluid for Footwear," the entire disclosure of which is incorporated herein by reference.

BACKGROUND

The present embodiments relate generally to footwear and in particular to articles of footwear having support members.

Articles of footwear generally include two primary elements: an upper and a sole structure. The upper is often formed from a plurality of material elements (e.g., textiles, polymer sheet layers, foam layers, leather, synthetic leather) that are stitched or adhesively bonded together to form a void on the interior of the footwear for comfortably and securely receiving a foot. More particularly, the upper forms a structure that extends over instep and toe areas of the foot, along medial and lateral sides of the foot, and around a heel area of the foot. The upper may also incorporate a lacing system to adjust the fit of the footwear, as well as permitting entry and removal of the foot from the void within the upper. In addition, the upper may include a tongue that extends under the lacing system to enhance adjustability and comfort of the footwear, and the upper may incorporate a heel counter.

The sole structure is secured to a lower portion of the upper so as to be positioned between the foot and the ground. In athletic footwear, for example, the sole structure may include a midsole and an outsole. The midsole may be formed from a polymer foam material that attenuates ground reaction forces (i.e., provides cushioning) during walking, running, and other ambulatory activities. The midsole may also include fluid-filled chambers, plates, moderators, or other elements that further attenuate forces, enhance stability, or influence the motions of the foot, for example. The outsole forms a ground-contacting element of the footwear and may be fashioned from a durable and wear-resistant rubber material that includes texturing to impart traction. The sole structure may also include a sockliner positioned within the upper and proximal a lower surface of the foot to enhance footwear comfort.

SUMMARY

In one aspect, an article of footwear includes a first support member having a first outer portion made of a compressible material and a first inner portion, where the first inner portion is filled with rheological fluid. The article of footwear also includes a second support member having a second outer portion made of a compressible material and a second inner portion, where the second inner portion is filled with rheological fluid. The article of footwear also includes a first reservoir in fluid communication with the first inner portion and a second reservoir in fluid communication with the second inner portion, a first electromagnetic device associated with the first support member, where the first electromagnetic device can be activated to vary the viscosity of the rheological fluid in the first inner portion and a second electromagnetic device associated with the second support member, where the second electromagnetic device

2

can be activated to vary the viscosity of the rheological fluid in the second inner portion. The first support member and the second support member are spaced apart from one another.

In another aspect, an article of footwear includes a support member having an outer portion made of a compressible material and an inner portion, where the inner portion is filled with a rheological fluid. The article of footwear also includes a reservoir in fluid communication with the inner portion and an electromagnetic device associated with the support member, where the electromagnetic device can be activated to vary the viscosity of the rheological fluid in the inner portion. The outer portion has an approximately cylindrical shape and the inner portion is generally coaxial with the outer portion.

In another aspect, an article of footwear includes a support member comprising a bladder with an outer chamber and an inner chamber, where the outer chamber is sealed from the inner chamber. The outer chamber is filled with a gas and the inner chamber is filled with a rheological fluid. The article of footwear also includes a reservoir in fluid communication with the inner chamber and an electromagnetic device associated with the support member, where the electromagnetic device can be activated to vary the viscosity of the rheological fluid in the inner chamber.

Other systems, methods, features and advantages of the embodiments will be, or will become, apparent to one of ordinary skill in the art upon examination of the following figures and detailed description. It is intended that all such additional systems, methods, features and advantages be included within this description and this summary, be within the scope of the embodiments, and be protected by the following claims.

BRIEF DESCRIPTION OF THE DRAWINGS

The embodiments can be better understood with reference to the following drawings and description. The components in the figures are not necessarily to scale, emphasis instead being placed upon illustrating the principles of the invention. Moreover, in the figures, like reference numerals designate corresponding parts throughout the different views.

FIG. 1 is a schematic isometric view of an embodiment of an article of footwear including an adaptive support system;

FIG. 2 is a schematic plan view of the article of FIG. 2;

FIG. 3 is a schematic view of an embodiment of some components of an adaptive support assembly;

FIG. 4 is a schematic cross-sectional view of some of the components shown in FIG. 3;

FIG. 5 is a schematic side view of an embodiment of some components of an adaptive support assembly in which a support member undergoes compression;

FIG. 6 is a schematic side view of an embodiment of some components of an adaptive support assembly in which the material properties of a support member are varied in response to a magnetic field;

FIG. 7 is a schematic side view of an embodiment of some components of an adaptive support assembly in which the material properties of a support member are varied in response to a magnetic field;

FIG. 8 is a schematic view of an embodiment some components of an adaptive support system;

FIG. 9 is an isometric view including an enlarged cross-section of another embodiment of a support member;

FIG. 10 is a schematic view of an embodiment of an article of footwear on a banked surface;

3

FIG. 11 is a schematic view of an embodiment of an article of footwear with support members that adaptively respond to contact with a banked surface;

FIG. 12 is a schematic view of an embodiment of an article of footwear undergoing banking; and

FIG. 13 is a schematic view of an embodiment of an article of footwear undergoing banking, where the support members adaptively respond to the banking.

DETAILED DESCRIPTION

FIG. 1 illustrates a schematic isometric view of an embodiment of an article of footwear **100**, also referred to simply as article **100**. Article **100** may be configured for use with various kinds of footwear including, but not limited to: hiking boots, soccer shoes, football shoes, sneakers, running shoes, cross-training shoes, rugby shoes, basketball shoes, baseball shoes as well as other kinds of shoes. Moreover, in some embodiments article **100** may be configured for use with various kinds of non-sports related footwear, including, but not limited to: slippers, sandals, high heeled footwear, loafers as well as any other kinds of footwear, apparel and/or sporting equipment (e.g., gloves, helmets, etc.).

Referring to FIG. 1, for purposes of reference, article **100** may be divided into forefoot portion **10**, midfoot portion **12** and heel portion **14**. Forefoot portion **10** may be generally associated with the toes and joints connecting the metatarsals with the phalanges. Midfoot portion **12** may be generally associated with the arch of a foot. Likewise, heel portion **14** may be generally associated with the heel of a foot, including the calcaneus bone. In addition, article **100** may include lateral side **16** and medial side **18**. In particular, lateral side **16** and medial side **18** may be opposing sides of article **100**. Furthermore, both lateral side **16** and medial side **18** may extend through forefoot portion **10**, midfoot portion **12** and heel portion **14**.

It will be understood that forefoot portion **10**, midfoot portion **12** and heel portion **14** are only intended for purposes of description and are not intended to demarcate precise regions of article **100**. Likewise, lateral side **16** and medial side **18** are intended to represent generally two sides of a component, rather than precisely demarcating article **100** into two halves.

For consistency and convenience, directional adjectives are employed throughout this detailed description corresponding to the illustrated embodiments. The term “longitudinal” as used throughout this detailed description and in the claims refers to a direction extending a length of a component. In some cases, the longitudinal direction may extend from a forefoot portion to a heel portion of the article. Also, the term “lateral” as used throughout this detailed description and in the claims refers to a direction extending a width of a component, such as an article. For example, the lateral direction may extend between a medial side and a lateral side of a last member. Furthermore, the term “vertical” as used throughout this detailed description and in the claims refers to a direction that is perpendicular to both the longitudinal and lateral directions. In situations where an article is placed on a ground surface, the upwards vertical direction may be oriented away from the ground surface, while the downwards vertical direction may be oriented towards the ground surface. It will be understood that each of these directional adjectives may be also be applied to individual components of article **100** as well.

Article **100** can include upper **102** and sole structure **110**. Generally, upper **102** may be any type of upper. In particular, upper **102** may have any design, shape, size and/or color. For

4

example, in embodiments where article **100** is a basketball shoe, upper **102** could be a high top upper that is shaped to provide high support on an ankle. In embodiments where article **100** is a running shoe, upper **102** could be a low top upper.

In some embodiments, sole structure **110** may be configured to provide traction for article **100**. In addition to providing traction, sole structure **110** may attenuate ground reaction forces when compressed between the foot and the ground during walking, running or other ambulatory activities. The configuration of sole structure **110** may vary significantly in different embodiments to include a variety of conventional or non-conventional structures. In some cases, the configuration of sole structure **110** can be configured according to one or more types of ground surfaces on which sole structure **110** may be used. Examples of ground surfaces include, but are not limited to: natural turf, synthetic turf, dirt, as well as other surfaces.

Sole structure **110** is secured to upper **102** and extends between the foot and the ground when article **100** is worn. In different embodiments, sole structure **110** may include different components. For example, sole structure **110** may include an outsole, a midsole, and/or an insole. In some cases, one or more of these components may be optional.

Some embodiments can include provisions for shock absorption, energy return, cushioning and/or comfort. In some embodiments, an article of footwear may be configured with an adaptive support system, which may include provisions for adaptively changing support for an article. In some embodiments, an adaptive support system can include one or more support members with variable support characteristics.

FIG. 2 illustrates a schematic plan view of an embodiment of article **100** that is configured with an adaptive support system **115**. In particular, some components of adaptive support system **115** may be seen in FIG. 1. Referring now to FIGS. 1 and 2, adaptive support system **115** may include one or more support members, which may facilitate shock absorption, energy return and/or cushioning, for example. In one embodiment, sole structure **110** may include plurality of support members **120** that further comprises first support member **121**, second support member **122**, third support member **123** and fourth support member **124**.

In some embodiments, plurality of support members **120** comprise individual members that are spaced apart from one another. In particular, first support member **121**, second support member **122**, third support member **123** and fourth support member **124** are arranged as column-like members that extend between upper plate **130** and lower plate **132**. With this arrangement, plurality of support members **120** may provide support to the heel of a foot, which is generally disposed over upper plate **130** of article **100**.

Also shown in FIG. 2 are various additional components of adaptive support system **115**, which are described in further detail below. It will be understood however, these components and their respective locations within article **100** are optional.

In some embodiments, one or more support members can be configured to provide adaptive support or response to forces applied to article **100** by a user's foot, a ground surface as well as possibly other sources. In some embodiments, one or more support members can be configured with adaptive shock-absorption, energy return and/or cushioning properties. In one embodiment, one or more support members can include a portion with variable shock-absorption, cushioning, rigidity and/or other properties.

5

FIGS. 3 and 4 illustrate an isolated view of an adaptive support assembly 199 that includes first support member 121 (also referred to simply as support member 121) as well as additional components that facilitate the operation of support member 121 in order to provide varying shock-absorption, cushioning and/or other properties for support member 121. In particular, FIG. 3 illustrates a schematic isometric view of adaptive support assembly 199, while FIG. 4 illustrates a schematic cross-sectional view of some components of adaptive support assembly 199. For purposes of clarity, many of the components of adaptive support assembly 199 are shown schematically, and it should be understood that these components could have any other shapes, sizes as well as possibly additional features in other embodiments.

Generally, as described in further detail below, a support member can be configured with an outer portion that is substantially compressible as well as an inner portion that is at least partially bounded by the outer portion. In some embodiments, whereas the outer portion may have a substantially fixed compressibility or rigidity, the compressibility or rigidity of the inner portion could be variable. In some embodiments, the variable compressibility of the inner portion can be achieved using a fluid having variable viscosity or structural characteristics. In one embodiment, the inner portion may be a cavity filled with a rheological fluid, including, for example, an electrorheological fluid or a magnetorheological fluid.

Referring to FIGS. 3 and 4, support member 121 can be configured as a bladder having an outer chamber 174 and an inner chamber 176. In some embodiments, the outer chamber 174 may be sealed from the inner chamber 176 so that no fluid can be exchanged between the outer chamber 174 and in the inner chamber 176.

Structurally, in some embodiments, support member 121 may be configured with an outer ring-like (or donut-like) member 161 surrounding a central region. The region encircled by member 161 may further be bounded above and below by an upper bladder wall 180 and a lower bladder wall 182. This arrangement creates a sealed inner chamber 176.

The upper bladder wall 180 and the lower bladder wall 182 may generally be attached to member 161 in a manner that prevents fluid from escaping between member 161 and upper bladder wall 180 and/or lower bladder wall 182. In some embodiments, upper bladder wall 180 and/or lower bladder wall 182 may be bonded to member 161 using adhesives, thermal bonding, as well as any other methods known in the art for joining layers of a bladder together. Moreover, in other embodiments, upper bladder wall 180 and/or lower bladder wall 182 could be integrally formed with member 161.

In some embodiments, first fluid 189 in the form of a gas or liquid may be sealed within the outer chamber 174, between an exterior bladder wall 170 and an interior bladder wall 172. Additionally, a second fluid 190 may fill inner chamber 176. In some embodiments, the first fluid 189 and the second fluid 190 could be substantially similar. In other embodiments, the first fluid 189 and the second fluid 190 could be substantially different. In one embodiment, the first fluid 189 may be air and the second fluid 190 may be a magnetorheological fluid. Therefore, first fluid 189 may be a substantially compressible gas, while second fluid 190 may be a substantially incompressible liquid.

Some embodiments may include provisions for allowing second fluid 190 to flow into and/or out of inner chamber 176. In some embodiments, lower bladder wall 182 may include a hole or aperture in the form of fluid port 198,

6

which allows second fluid 190 to enter/escape from inner chamber 176. Additionally, some embodiments further include a fluid line 196 that facilitates fluid communication between fluid port 198 and a reservoir 194. Although a fluid port 198 is shown in lower bladder wall 182 in this embodiment, other embodiments could incorporate a fluid port in any other portion including, for example upper bladder wall 180.

Reservoir 194, shown schematically in the figures, may house some of the total volume of the second fluid 190, which can flow between reservoir 194 and inner chamber 176, by way of fluid line 196. It will be understood that the shape, size and structural properties of reservoir 194 may vary according to factors including, but not limited to: the total volume of second fluid 190, the volume of inner chamber 176, the volume of fluid line 196, the intended location within an article of reservoir 194, manufacturing considerations as well as possibly other factors.

A possible mode of operation of adaptive support assembly 199 is shown schematically in FIG. 5. Referring now to FIG. 5, a downward force 200 applied to first support member 121 may act to compress support member 121 in the generally vertical direction. In this situation, outer chamber 174, which is filled with a compressible gas such as air, may temporarily deform or deflect under downward force 200. In addition, second fluid 190, which is generally an incompressible fluid, is pushed through fluid line 196 and into reservoir 194, thereby allowing inner chamber 176 to deform or deflect along with outer chamber 174. Furthermore, the compression of gas within outer chamber 174 stores potential kinetic energy that may cause outer chamber 174 (and with it inner chamber 176) to expand as downward force 200 is diminished and/or completely removed. This arrangement allows first support member 121 to act as a shock-absorber and to provide some energy return.

Referring back to FIGS. 3 and 4, the overall compressibility of first support member 121 is due to the combination of the material properties of the first fluid 189 in outer chamber 174 and the material properties of second fluid 190 in inner chamber 176. Because outer chamber 174 is sealed and the material properties of first fluid 189 are generally unchanged, the compressibility of outer chamber 174 is generally constant and unchanging. However, as second fluid 190 has variable material properties, including viscosity, it is possible to vary the compressibility of inner chamber 176 and therefore the overall compressibility of first support member 121.

As seen in FIG. 3, adaptive support assembly 199 may include provisions for controlling the material properties (such as viscosity) of second fluid 190. In some embodiments, assembly 199 may include an electromagnet device. Examples of electromagnetic devices include electrical devices, such as capacitors, as well as magnetic devices such as electromagnets. In some embodiments, an electromagnet device may also comprise a permanent magnet. The type of electromagnetic device used may be selected according to the material properties of second fluid 190. For example, where an electrorheological fluid is used, an electromagnetic device may be a capacitor or other electrical device capable of generating an electrical field. In cases where a magnetorheological fluid is used, the electromagnetic device may be an electromagnet.

In one embodiment, adaptive support assembly 199 may include electromagnet 186. Generally, any kind of electromagnet or electromagnetic device known in the art could be used. Moreover, the type of electromagnet used could be selected according to factors including, but not limited to:

required field strength, required location within the article, durability, power requirements as well as possibly other factors.

Although shown schematically in the figures, electromagnet **186** may generally be positioned so that the required range of magnetic forces can be applied to second fluid **190**. In some embodiments, electromagnet **186** can be positioned so that the magnetic field primarily interacts with the volume of second fluid **190** disposed in inner chamber **176**. In other embodiments, electromagnet **186** may be positioned so that the magnetic field primarily interacts with the volume of second fluid **190** disposed in fluid line **196**, especially in the vicinity of fluid port **198**. In still other embodiments, electromagnet **186** may be positioned so that the magnetic field primarily interacts with the volume of second fluid **190** disposed in reservoir **194**. In still further embodiments, electromagnet **186** may be positioned so that the magnetic field interacts with portions of the volume of second fluid **190** disposed within each of reservoir **194**, fluid line **196** and inner chamber **176**.

Electromagnet **186** may apply a magnetic field to regions of second fluid **190** that alter the material properties, including the apparent viscosity, of second fluid **190**. Varying the viscosity of regions of second fluid **190** may change the rate of fluid flow between inner chamber **176** and reservoir **194**. In cases where the viscosity is greatly increased at some regions of second fluid **190**, the flow may be substantially stopped. As the viscosity varies in response to the magnetic field, thereby restricting or completely preventing fluid flow, the compressibility of inner chamber **176** (and thus of first support member **121**) may vary accordingly. For example, if the viscosity of second fluid **190** is high enough to stop flow of second fluid **190** through fluid port **198**, inner chamber **176** may remain filled with second fluid **190** and therefore unable to deform, deflect or otherwise vary in shape and/or volume. Moreover, by varying the viscosity, the rate of flow of second fluid **190** can change so that the rate of deformation or deflection, and therefore the compressibility, of inner chamber **176** can be varied accordingly.

In particular, the general incompressibility of second fluid **190** means that the compressibility of inner chamber **176** may be influenced by changes in the fluid viscosity that occur both inside and outside of inner chamber **176**. Thus, it is possible to adjust the compressibility of inner chamber **176** by modifying the viscosity of second fluid **190** at any of reservoir **194**, fluid line **196** and/or inner chamber **176**. In one embodiment, for example, electromagnet **186** may be positioned in the vicinity of fluid port **198**, so that a magnetic field generated by electromagnet **186** can change the viscosity of second fluid **190** at fluid port **198** as well as possibly within inner chamber **176**. This may result in fluid port **198** being substantially closed (i.e., clogged) so that no fluid can flow from inner chamber **176**.

In order to control electromagnet **186**, some embodiments may further include an electronic control unit **150**, hereafter referred to simply as ECU **150**. ECU **150** is described in further detail below.

Although the current embodiment uses an electromagnet that is actuated by ECU **150**, other embodiments could use a permanent magnet to vary the viscosity of second fluid **190**. In another embodiment, a permanent magnet could be configured with a position that varies relative to regions of second fluid **190**. As the permanent magnet moves closer to second fluid **190**, the increased magnetic field strength increases the viscosity of second fluid **190**. This could be accomplished, for example, by placing a compressible material between the magnet and the associated region of second

fluid **190**, so that as the compressible material is squeezed (e.g., during a ground-contact), the relative distance between the magnet and second fluid **190** decreases. In still other embodiments, a permanent magnet could be associated with an actuating member that automatically adjusts the relative position of the magnet with respect to a corresponding region of second fluid **190**.

FIGS. **6** and **7** illustrate schematic views of two additional operating modes for adaptive support assembly **199**. Referring to FIG. **6**, electromagnet **186** is operated with a substantially maximum magnetic field strength **210**. In this mode, the viscosity of second fluid **190** within inner chamber **176** and in the portion of fluid line **196** adjacent to inner chamber **176** may be greatly increased to the point where substantially no fluid flow is possible even with the application of downward forces **200**. In this highly viscous state, second fluid **190** remains trapped in inner chamber **176** and thereby prevents first support member **121** from compressing. Referring next to FIG. **7**, electromagnet **186** is operated with an intermediate magnetic field strength **212** that is less than the maximum magnetic field strength **210**. In this mode, the viscosity of second fluid **190** within inner chamber **176** and in the portion of fluid line **196** adjacent to inner chamber **176** may be increased to a point where fluid flow is diminished but not completely stopped. Thus, in this state, second fluid **190** can flow at a substantially reduced rate from inner chamber **176**, which allows for some compression of first support member **121**. However, as seen by comparing FIG. **7** with FIG. **5**, with electromagnet **186** partially energized (FIG. **7**), the amount of compression experienced by support member **121** is substantially less than the amount of compression experienced by support member **121** with electromagnet **186** off (FIG. **5**).

Provisions for returning inner chamber **176** to a pre-compressed state may vary in different embodiments. In one embodiment, reservoir **194** may be partially filled with a compressible gas, which may compress as second fluid **190** fills reservoir **194**. As downward forces **200** are diminished, the compressed gas in reservoir **194** may expand to push second fluid **190** back into inner chamber **176**. In other embodiments, reservoir **194** may further include one or more actuating systems to push second fluid **190** out of reservoir **194** and into inner chamber **176** (e.g., a piston that reduces the volume of reservoir **194**).

The embodiments shown in the figures and discussed here are only intended to be exemplary. Still other embodiments of an adaptive support assembly could include additional provisions for controlling the flow of second fluid **190**. For example, other embodiments could include additional valves or other fluid controlling provisions to facilitate fluid flow in the desired direction and at the desired rate in response to various compressive forces.

FIG. **8** illustrates a schematic view of an embodiment of adaptive support system **115** that may include plurality of support members **120** as well as provisions for controlling the material properties of each support member. As previously discussed, plurality of support members **120** may include first support member **121**, second support member **122**, third support member **123** and fourth support member **124**. Each support member can be configured with similar provisions to first support member **121** for adaptively controlling compression, shock-absorption, etc. For example, each of second support member **122**, third support member **123** and fourth support member **124** may be associated with second reservoir **302**, third reservoir **304** and fourth reservoir **306**, respectively, as well as associated fluid lines. Likewise, each of second support member **122**, third support

member **123** and fourth support member **124** may be associated with second electromagnet **310**, third electromagnet **312** and fourth electromagnet **314**, respectively.

In some embodiments, each electromagnet may be controlled using one or more electronic control units. In one embodiment, each electromagnet can be associated with ECU **150**. Still other embodiments could utilize two or more distinct control units. ECU **150** may include a microprocessor, RAM, ROM, and software all serving to monitor and control various components of adaptive support system **199**, as well as other components or systems of article **100**. For example, ECU **150** is capable of receiving signals from numerous sensors, devices, and systems associated with adaptive support system **199**. The output of various devices is sent to ECU **150** where the device signals may be stored in an electronic storage, such as RAM. Both current and electronically stored signals may be processed by a central processing unit (CPU) in accordance with software stored in an electronic memory, such as ROM.

ECU **150** may include a number of ports that facilitate the input and output of information and power. The term “port” as used throughout this detailed description and in the claims refers to any interface or shared boundary between two conductors. In some cases, ports can facilitate the insertion and removal of conductors. Examples of these types of ports include mechanical connectors. In other cases, ports are interfaces that generally do not provide easy insertion or removal. Examples of these types of ports include soldering or electron traces on circuit boards.

All of the following ports and provisions associated with ECU **150** are optional. Some embodiments may include a given port or provision, while others may exclude it. The following description discloses many of the possible ports and provisions that can be used, however, it should be kept in mind that not every port or provision must be used or included in a given embodiment.

In some embodiments, ECU **150** may include port **351**, port **352**, port **353** and port **354** for communicating with first electromagnet **186**, second electromagnet **310**, third electromagnet **312** and fourth electromagnet **314**, respectively. Furthermore, in some embodiments ECU **150** may further include port **355**, port **356** and port **357** for communicating with sensor **320**, sensor **322** and sensor **324**, respectively. Sensor **320**, sensor **322** and sensor **324** could be any sensors configured for use with footwear and/or apparel. In some embodiments, sensor **320**, sensor **322** and sensor **324** may be a pressure sensor, a force or strain sensor and an accelerometer. In other embodiments, however, still other sensors could be used. Some embodiments, for example, could also include provisions for receiving GPS information via a GPS antenna. Examples of various sensors and sensor locations that can be incorporated into an article of footwear are disclosed in Molyneux et al., U.S. Patent Application Publication Number 2012/0234111, now U.S. patent application Ser. No. 13/399,786, filed Feb. 17, 2012, and titled “Footwear Having Sensor System”, the entirety of which is hereby incorporated by reference.

The configuration shown here provides a system where each support member can be independently actuated through instructions from ECU **150**. In particular, this arrangement allows the material properties of each support member (i.e., the viscosity of an enclosed magnetorheological fluid) to be independently varied in response to various sensed information including acceleration information, angle or rotation information, speed information, vertical height information, pressure information as well as other kinds of information. This allows an article of footwear to adaptively respond to

a variety of different situations with the proper type and amount of shock-absorption, cushioning, energy return and comfort.

FIG. **9** illustrates another possible embodiment of a support member **400** configured to have variable material properties. Referring to FIG. **9**, support member **400** includes an outer portion **402** comprising a substantially compressible material as well as an inner portion **404**. In some embodiments, inner portion **404** may be comprise an outer barrier layer **405** that encloses a fluid **406**.

In some embodiments, fluid **406** is a variable viscosity fluid, such as an electrorheological or magnetorheological fluid. As with the previous embodiments, the viscosity of fluid **406** may vary in response to an applied magnetic field. Furthermore, though not shown here, layer **405** may include a fluid port **409** that provides fluid communication between inner portion **404** and an external reservoir of some kind. This arrangement allows fluid **406** to flow into and out of inner portion **404** in a similar manner to the flow of second fluid **190** into and out of inner chamber **176** (see FIG. **5**).

In some embodiments, outer portion **402** comprises a substantially solid material, rather than a gas filled bladder. Examples of solid compressible materials that could be used include, but are not limited to: foams, compressible plastics as well as possibly other materials. The type of material used for outer portion **402** may be selected according to factors including, but not limited to: manufacturing constraints, desired compressibility, durability, weight, as well as possibly other factors. In still other embodiments, however, outer portion **402** may comprise a bladder, such as member **161** of the previous embodiments.

Referring back to FIG. **2**, one possible arrangement of components of adaptive support system **115** within article **100** is shown schematically. In this case, first support member **121**, second support member **122**, third support member **123** and fourth support member **124** are each configured with respective outer portions and inner portions. For example, first support member **121** includes an outer portion including outer chamber **174** and an inner portion including inner chamber **176**. Likewise, as another example, second support member **122** includes an outer portion including an outer chamber **220** and an inner portion including an inner chamber **222**. Each of these inner portions have inner chambers filled with a magnetorheological fluid. Moreover, as previously discussed, each support member is in fluid communication with a fluid reservoir, including first reservoir **194**, second reservoir **302**, third reservoir **304** and fourth reservoir **306**. Each reservoir can be disposed in any region of article **100**. In some cases, each reservoir could be mounted to portions of sole structure **110**. In other cases, each reservoir could be mounted to portions of upper **102** (not shown). In still other cases, each reservoir could be positioned and mounted in any other portions or locations of article **100**.

Furthermore, each of the support members includes an electromagnet positioned adjacent to the corresponding support member, including first electromagnet **186**, second electromagnet **310**, third electromagnet **312** and fourth electromagnet **314**. The electromagnets could be disposed in any portion of article **100** including sole structure **110** and/or upper **102**.

As seen in FIG. **2**, first support member **121**, second support member **122**, third support member **123** and fourth support member **124** are generally spaced apart so as to facilitate support over different portions of sole structure **110**. This spacing facilitates differentiated shock absorption, and may allow for various configurations in which some

11

support members are operated in different operating states or modes than other support members. Such a configuration may occur, for example, during banking.

FIG. 10 illustrates another embodiment of an article 500 that is banked on a ground surface 502. Article 500 includes an upper 512 and a sole structure 510. Here, the vertical direction is indicated by axis 520, while the direction normal to ground surface 502 is indicated by axis 522. As seen in FIG. 10, both upper 512 and sole structure 510 are oriented along axis 522. In other words, both upper 512 and sole structure 510 are oriented, or tilted, at an angle from the true vertical direction.

FIG. 11 illustrates an embodiment of article 100 banked on a similarly inclined ground surface 602, which shows how article 100 may adaptively respond to changes in surface characteristics (such as surface orientation, angle or shape). Here, the vertical direction is indicated by axis 620. Here, lower plate 132 of sole structure 110 is sloped along with ground surface 602. However, in this embodiment, electromagnet 312 has been activated in order to change the viscosity of the magnetorheological fluid within third support member 123, thereby preventing full compression of third support member 123. In some embodiments, this activation of electromagnet 312 may occur in response to sensed information, such as information sensed from an accelerometer and/or gyroscope. In contrast, second support member 122, experiencing no magnetic forces from electromagnet 310, is compressed to a greater degree than third support member 123. This variation in compression allows upper plate 130 of sole structure 110 to remain in a generally horizontal position so that both upper plate 130 and upper 102 remain approximately aligned with vertical axis 620. Thus, adaptive support system 199 allows upper 102 to remain generally upright without any leaning or tilting that might otherwise occur during banking. This may help improve stability and balance for a user when moving along banked or uneven surfaces.

FIGS. 12 and 13 illustrate views of footwear undergoing banking on a flat surface, which may occur as a user cuts or makes similar lateral movements (for example, on a track or basketball court). FIG. 12 shows article of footwear 700 as a user makes a lateral cut on a substantially flat ground surface 702. Article 700 includes an upper 712 and a sole structure 710. As the user cuts, the foot tends to push against the outer lateral sidewall 704 (indicated schematically as forces 720). This may tend to cause article 700 to roll or tilt about lower lateral periphery 706.

FIG. 13 illustrates an embodiment of article of footwear 100 in which a user is making a lateral cut. Moreover, FIG. 13 illustrates how article of footwear 100 may adaptively respond to various kinds of motions such as cutting or lateral motions to help improve stability during these motions. As in FIG. 12, during this cutting motion the foot tends to push against the outer lateral sidewall 804 (indicated schematically as forces 820). However, in this case adaptive support system 115 responds to this shift in weight by allowing third support member 123 to compress substantially more than second support member 122. This results in a wedge-like configuration for sole structure 110 that resists the tendency of article 100 to roll in the lateral direction about the lower lateral periphery 806 and thereby helps to improve stability. Moreover, as the weight distribution continues to change during the lateral movement (or during a sequence of lateral movements) as well as in transitions to other kind of movements, adaptive support system 115 may continue to adjust the compression characteristics of each support member accordingly.

12

While various embodiments have been described, the description is intended to be exemplary, rather than limiting and it will be apparent to those of ordinary skill in the art that many more embodiments and implementations are possible that are within the scope of the embodiments. Accordingly, the embodiments are not to be restricted except in light of the attached claims and their equivalents. Also, various modifications and changes may be made within the scope of the attached claims.

What is claimed is:

1. An article of footwear, comprising:

a support member having an outer portion made of a compressible material and an inner portion filled with a fluid, the support member disposed on one of a lateral side and a medial side of the article of footwear;

a sensor disposed adjacent to the support member;

a reservoir separate from the inner portion by a distance and in fluid communication with the inner portion via a tubular fluid line;

an electromagnetic device configured to be activated to increase a viscosity of the fluid in the inner portion in response to sensed information from the sensor.

2. The article of footwear according to claim 1, wherein the fluid in the inner portion is one of an electrorheological fluid and a magnetorheological fluid.

3. The article of footwear according to claim 1, wherein the sensor is an accelerometer.

4. The article of footwear according to claim 1, wherein the sensor is a gyroscope.

5. The article of footwear according to claim 1, wherein, upon the sensed information indicating that the support member is experiencing higher compression forces than a second member is experiencing at a different one of the lateral side and the medial side from the support member, the electromagnetic device is configured to increase the viscosity of the fluid in the inner portion.

6. The article of footwear according to claim 1, further comprising a lower plate having a ground-engaging surface, wherein, upon the sensed information indicating that the lower plate is engaging with an uneven surface, the electromagnetic device is configured to increase the viscosity of the fluid.

7. The article of footwear according to claim 1, wherein, upon the sensed information indicating that the article of footwear is experiencing a cutting motion made by a wearer of the article of footwear, the electromagnetic device is configured to increase the viscosity of the fluid.

8. An article of footwear, comprising:

an upper:

an upper plate disposed adjacent the upper;

a lower plate disposed opposite the upper plate, the lower plate having a ground-engaging surface;

a support member extending between the upper plate and lower plate disposed on one of a lateral side and a medial side of the article of footwear, the support member having an outer portion made of a compressible material and an inner portion, wherein the inner portion is filled with fluid;

a sensor disposed adjacent the support member and configured to indicate a position of the upper plate with respect to the lower plate;

a reservoir separate from the inner portion by a distance and in fluid communication with the inner portion via a tubular fluid line;

an electromagnetic device associated with the first support member, wherein the electromagnetic device is config-

13

ured to be activated to vary a viscosity of the fluid in the inner portion in response to sensed information from the sensor.

9. The article of footwear according to claim 8, wherein the position of the upper plate is adjusted to cause the upper plate to be closer to the lower plate on one of the medial side and the lateral side of the article of footwear than the other of the medial side and the lateral side.

10. The article of footwear according to claim 8, wherein the outer portion has an approximately cylindrical shape, and wherein the inner portion are generally coaxial with the outer portion.

11. The article of footwear according to claim 8, wherein the first outer portion is solid material.

12. The article of footwear according to claim 8, wherein the outer portion comprises an outer chamber of a bladder and the inner portion comprises an inner chamber of the bladder.

13. A method, comprising:

coupling a support member to a sole structure of an article of footwear on one of a lateral side and a medial side of the article of footwear, the support member having an outer portion made of a compressible material and an inner portion, wherein the inner portion is filled with fluid;

disposing a sensor adjacent to the first support member;

placing a reservoir separate from the inner portion by a distance and in fluid communication with the inner portion via a tubular fluid line;

14

coupling an electromagnetic device to the reservoir, the electromagnetic device configured to be activated to increase a viscosity of the fluid in the inner portion in response to sensed information from the sensor.

14. The method according to claim 13, wherein the fluid in the first inner portion and the second inner portion is one of an electrorheological fluid and a magnetorheological fluid.

15. The method according to claim 13, wherein the sensor is an accelerometer.

16. The method according to claim 13, wherein the sensor is a gyroscope.

17. The method according to claim 13, wherein, upon the sensed information indicating that the support member is experiencing higher compression, the electromagnetic device is configured to increase the viscosity of the fluid in the inner portion.

18. The method according to claim 13, wherein, upon the sensed information indicating that a lower plate having a ground-engaging surface is engaging with an uneven surface, the electromagnetic device is configured to increase the viscosity of the fluid.

19. The method according to claim 13, wherein, upon the sensed information indicating that the article of footwear is experiencing a cutting motion made by a wearer of the article of footwear, one the electromagnetic device is configured to increase the viscosity of the fluid.

* * * * *