



US011477386B2

(12) **United States Patent**
Shabtay et al.

(10) **Patent No.:** **US 11,477,386 B2**
(45) **Date of Patent:** ***Oct. 18, 2022**

(54) **MULTI-APERTURE CAMERAS WITH AT LEAST ONE TWO STATE ZOOM CAMERA**

(71) Applicant: **Corephotonics Ltd.**, Tel Aviv (IL)

(72) Inventors: **Gal Shabtay**, Tel Aviv (IL); **Ephraim Goldenberg**, Tel Aviv (IL); **Roy Rudnick**, Tel Aviv (IL); **Michael Dror**, Tel Aviv (IL); **Gil Bachar**, Tel Aviv (IL); **Emil Bronstein**, Tel Aviv (IL); **Itay Yedid**, Tel Aviv (IL)

(73) Assignee: **Corephotonics Ltd.**, Tel Aviv (IL)

(*) Notice: Subject to any disclaimer, the term of this patent is extended or adjusted under 35 U.S.C. 154(b) by 0 days.

This patent is subject to a terminal disclaimer.

(21) Appl. No.: **17/717,083**

(22) Filed: **Apr. 10, 2022**

(65) **Prior Publication Data**
US 2022/0232167 A1 Jul. 21, 2022

Related U.S. Application Data

(63) Continuation of application No. 16/975,721, filed as application No. PCT/IB2020/050002 on Jan. 1, 2020, now Pat. No. 11,336,830.
(Continued)

(51) **Int. Cl.**
H04N 5/232 (2006.01)
G02B 15/14 (2006.01)
(Continued)

(52) **U.S. Cl.**
CPC **H04N 5/23296** (2013.01); **G02B 13/02** (2013.01); **G02B 15/143103** (2019.08);
(Continued)

(58) **Field of Classification Search**
CPC H04N 5/23296; H04N 5/2253; H04N 5/2258; H04N 5/2178; H04N 5/23287;
(Continued)

(56) **References Cited**
U.S. PATENT DOCUMENTS

2,106,752 A 2/1938 Land
2,354,503 A 7/1944 Cox
(Continued)

FOREIGN PATENT DOCUMENTS

CN 102193162 A 9/2011
CN 102147519 B 1/2013
(Continued)

OTHER PUBLICATIONS

A compact and cost effective design for cell phone zoom lens, Chang et al., Sep. 2007, 8 pages.
(Continued)

Primary Examiner — Pritham D Prabhakher
(74) *Attorney, Agent, or Firm* — Nathan & Associates;
Menachem Nathan

(57) **ABSTRACT**
Multi-cameras and in particular dual-cameras comprising a Wide camera comprising a Wide lens and a Wide image sensor, the Wide lens having a Wide effective focal length EFL_w and a folded Tele camera comprising a Tele lens with a first optical axis, a Tele image sensor and an OPFE, wherein the Tele lens includes, from an object side to an image side, a first lens element group G1, a second lens element group G2 and a third lens element group G3, wherein at least two of the lens element groups are movable relative to the image sensor along the first optical axis to bring the Tele lens to two zoom states, wherein an effective focal length (EFL) of the Tele lens is changed from $EFL_{T,min}$
(Continued)

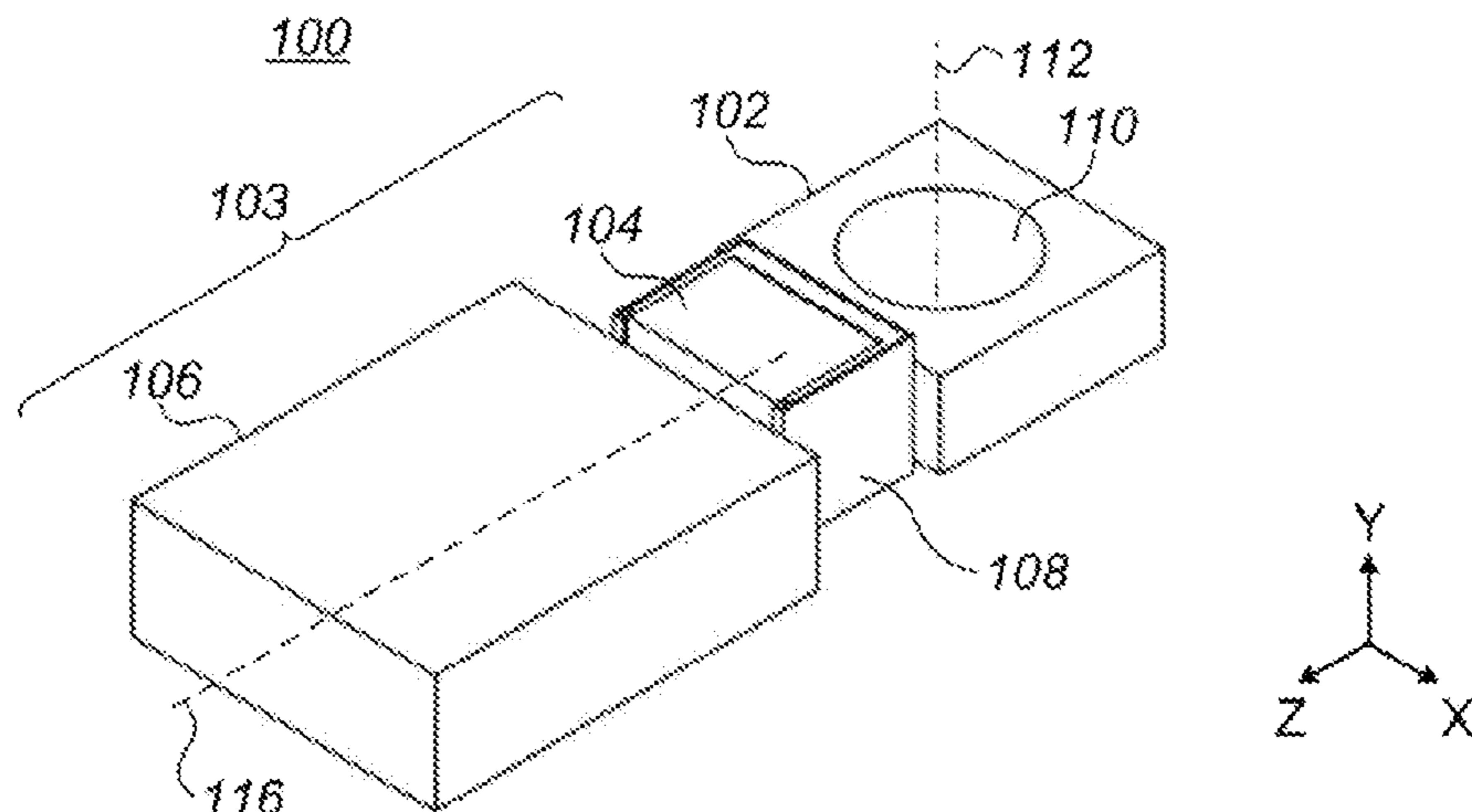

in one zoom state to $EFL_{T,max}$ in the other zoom state, wherein $EFL_{T,min} > 1.5 \times EFL_w$ and wherein $EFL_{T,max} > 1.5 \times EFL_{T,min}$.

20 Claims, 20 Drawing Sheets

Related U.S. Application Data

- (60) Provisional application No. 62/809,871, filed on Feb. 25, 2019, provisional application No. 62/787,826, filed on Jan. 3, 2019.
- (51) **Int. Cl.**
G02B 13/02 (2006.01)
G03B 3/10 (2021.01)
H04N 5/225 (2006.01)
- (52) **U.S. Cl.**
 CPC *G03B 3/10* (2013.01); *H04N 5/2253* (2013.01); *H04N 5/2254* (2013.01)
- (58) **Field of Classification Search**
 CPC H04N 5/23212; H04N 5/1211; H04N 5/2254; G02B 15/143103; G02B 13/02; G02B 13/009; G02B 13/0065; G03B 3/10; G03B 5/00; G03B 17/17; G03B 17/12; G03B 13/22
 USPC 348/345
 See application file for complete search history.

(56) **References Cited**

U.S. PATENT DOCUMENTS

2,378,170	A	6/1945	Aklin	
2,441,093	A	5/1948	Aklin	
3,388,956	A	6/1968	Eggert et al.	
3,524,700	A	8/1970	Eggert et al.	
3,558,218	A	1/1971	Grey	
3,864,027	A	2/1975	Harada	
3,942,876	A	3/1976	Betensky	
4,134,645	A	1/1979	Sugiyama et al.	
4,249,798	A *	2/1981	Moskovich	G02B 15/144511 359/683
4,338,001	A	7/1982	Matsui	
4,465,345	A	8/1984	Yazawa	
5,000,551	A	3/1991	Shibayama	
5,969,869	A	10/1999	Hirai et al.	
6,014,266	A	1/2000	Obama et al.	
6,147,702	A	11/2000	Smith	
6,169,636	B1	1/2001	Kreitzer	
6,654,180	B2	11/2003	Ori	
7,187,504	B2	3/2007	Horiuchi	
7,206,136	B2	4/2007	Labaziewicz et al.	
7,436,599	B2 *	10/2008	Mihara	G02B 13/006 359/733
7,515,351	B2	4/2009	Chen et al.	
7,564,635	B1	7/2009	Tang	
7,643,225	B1	1/2010	Tsai	
7,660,049	B2	2/2010	Tang	
7,684,128	B2	3/2010	Tang	
7,688,523	B2	3/2010	Sano	
7,692,877	B2	4/2010	Tang et al.	
7,697,220	B2	4/2010	Iyama	
7,738,186	B2	6/2010	Chen et al.	
7,777,972	B1	8/2010	Chen et al.	
7,813,057	B2	10/2010	Lin	
7,821,724	B2	10/2010	Tang et al.	
7,826,149	B2	11/2010	Tang et al.	
7,826,151	B2	11/2010	Tsai	
7,869,142	B2	1/2011	Chen et al.	
7,880,978	B2 *	2/2011	Neil	G02B 13/18 359/717

7,898,747	B2	3/2011	Tang	
7,916,401	B2	3/2011	Chen et al.	
7,918,398	B2	4/2011	Li et al.	
7,957,075	B2	6/2011	Tang	
7,957,076	B2	6/2011	Tang	
7,957,079	B2	6/2011	Tang	
7,961,406	B2	6/2011	Tang et al.	
8,000,031	B1	8/2011	Tsai	
8,004,777	B2	8/2011	Souma	
8,077,400	B2	12/2011	Tang	
8,120,693	B2 *	2/2012	Nomura	H04N 5/225251 359/372
8,149,523	B2	4/2012	Ozaki	
8,218,253	B2	7/2012	Tang	
8,228,622	B2	7/2012	Tang	
8,233,224	B2	7/2012	Chen	
8,253,843	B2	8/2012	Lin	
8,279,537	B2	10/2012	Sato	
8,363,337	B2	1/2013	Tang et al.	
8,395,851	B2	3/2013	Tang et al.	
8,400,717	B2	3/2013	Chen et al.	
8,451,549	B2	5/2013	Yamanaka et al.	
8,503,107	B2	8/2013	Chen et al.	
8,514,502	B2	8/2013	Chen	
8,570,668	B2	10/2013	Takakubo et al.	
8,718,458	B2	5/2014	Okuda	
8,780,465	B2	7/2014	Chae	
8,810,923	B2	8/2014	Shinohara	
8,854,745	B1	10/2014	Chen	
8,958,164	B2	2/2015	Kwon et al.	
9,185,291	B1	11/2015	Shabtay et al.	
9,229,194	B2	1/2016	Yoneyama et al.	
9,235,036	B2	1/2016	Kato et al.	
9,279,957	B2	3/2016	Kanda et al.	
9,438,792	B2	9/2016	Nakada et al.	
9,479,686	B2 *	10/2016	Kreitzer	G02B 15/142
9,488,802	B2	11/2016	Chen et al.	
9,568,712	B2	2/2017	Dror et al.	
9,678,310	B2	6/2017	Iwasaki et al.	
9,817,213	B2	11/2017	Mercado	
9,897,780	B1 *	2/2018	Bone	G02B 13/0065
10,070,060	B2 *	9/2018	Goldenberg	G03B 17/17
10,554,868	B2 *	2/2020	Tang	H04N 5/2258
10,571,644	B2 *	2/2020	Shabtay	H04N 5/2259
10,598,890	B2 *	3/2020	Kim	G02B 7/021
10,775,596	B2 *	9/2020	Hu	G02B 7/09
10,788,651	B2 *	9/2020	Bae	G02B 13/02
11,333,849	B2 *	5/2022	Lee	G02B 9/60
2002/0118471	A1	8/2002	Imoto	
2005/0041300	A1	2/2005	Oshima et al.	
2005/0062346	A1	3/2005	Sasaki	
2005/0128604	A1	6/2005	Kuba	
2005/0141103	A1	6/2005	Nishina	
2005/0168840	A1	8/2005	Kobayashi et al.	
2005/0270667	A1	12/2005	Gurevich et al.	
2006/0187312	A1 *	8/2006	Labaziewicz	H04N 5/2254 348/E5.042
2006/0238902	A1	10/2006	Nakashima et al.	
2007/0229983	A1	10/2007	Saori	
2008/0056698	A1	3/2008	Lee et al.	
2008/0094730	A1	4/2008	Toma et al.	
2008/0304161	A1	12/2008	Souma	
2009/0002839	A1	1/2009	Sato	
2009/0067063	A1	3/2009	Asami et al.	
2009/0122423	A1	5/2009	Park et al.	
2009/0141365	A1	6/2009	Jannard et al.	
2009/0147368	A1	6/2009	Oh et al.	
2009/0225438	A1	9/2009	Kubota	
2010/0165476	A1	7/2010	Eguchi	
2010/0277813	A1	11/2010	Ito	
2011/0001838	A1	1/2011	Lee	
2011/0115965	A1	5/2011	Engelhardt et al.	
2011/0149119	A1	6/2011	Matsui	
2011/0157430	A1	6/2011	Hosoya et al.	
2011/0188121	A1	8/2011	Goring et al.	
2011/0249347	A1	10/2011	Kubota	
2012/0069455	A1	3/2012	Lin et al.	
2012/0092777	A1	4/2012	Tochigi et al.	
2012/0105708	A1	5/2012	Hagiwara	

(56)

References Cited

FOREIGN PATENT DOCUMENTS

U.S. PATENT DOCUMENTS

2012/0154929	A1	6/2012	Tsai et al.	
2012/0229920	A1	9/2012	Otsu et al.	
2012/0262806	A1	10/2012	Lin et al.	
2013/0057971	A1	3/2013	Zhao et al.	
2013/0088788	A1	4/2013	You	
2013/0208178	A1	8/2013	Park	
2013/0279032	A1	10/2013	Suigetsu et al.	
2013/0286488	A1	10/2013	Chae	
2014/0022436	A1	1/2014	Kim et al.	
2014/0092487	A1	4/2014	Chen et al.	
2014/0146216	A1	5/2014	Okumura	
2014/0204480	A1	7/2014	Jo et al.	
2014/0285907	A1	9/2014	Tang et al.	
2014/0293453	A1	10/2014	Ogino et al.	
2014/0362274	A1	12/2014	Christie et al.	
2015/0116569	A1	4/2015	Mercado	
2015/0215541	A1*	7/2015	Nomura	H04N 5/23287 348/208.11
2015/0234149	A1*	8/2015	Kreitzer	H04N 5/2259 348/240.3
2015/0244942	A1	8/2015	Shabtay et al.	
2015/0253532	A1	9/2015	Lin	
2015/0253543	A1	9/2015	Mercado	
2015/0253647	A1	9/2015	Mercado	
2015/0373252	A1	12/2015	Georgiev	
2015/0373263	A1	12/2015	Georgiev et al.	
2016/0004047	A1*	1/2016	Iwasaki	G02B 27/0025 359/714
2016/0044250	A1	2/2016	Shabtay et al.	
2016/0062084	A1	3/2016	Chen et al.	
2016/0070088	A1	3/2016	Koguchi	
2016/0085089	A1	3/2016	Mercado	
2016/0187631	A1	6/2016	Choi et al.	
2016/0291295	A1	10/2016	Shabtay	
2016/0306161	A1	10/2016	Harada et al.	
2016/0313537	A1	10/2016	Mercado	
2016/0341931	A1	11/2016	Liu et al.	
2016/0353008	A1	12/2016	Osborne	
2017/0102522	A1	4/2017	Jo	
2017/0115471	A1	4/2017	Shinohara	
2017/0160511	A1	6/2017	Kim et al.	
2018/0059365	A1	3/2018	Bone et al.	
2018/0217475	A1	8/2018	Goldenberg et al.	
2018/0224630	A1	8/2018	Lee et al.	
2019/0170965	A1	6/2019	Shabtay	
2020/0221026	A1	7/2020	Fridman et al.	

CN	104297906	A	1/2015
CN	105467563	A	4/2016
JP	S54157620	A	12/1979
JP	S59121015	A	7/1984
JP	6165212	A	4/1986
JP	S6370211	A	3/1988
JP	406059195	A	3/1994
JP	H11223771	A	8/1999
JP	2004334185	A	11/2004
JP	2006195139	A	7/2006
JP	2007133096	A	5/2007
JP	2007219199	A	8/2007
JP	2007306282	A	11/2007
JP	2008191423	A	8/2008
JP	2010164841	A	7/2010
JP	2012203234	A	10/2012
JP	2013105049	A	5/2013
JP	2013106289	A	5/2013
JP	2014142542	A	8/2014
KR	20090131805	A	12/2009
KR	20140135909	A	5/2013
KR	20140023552	A	2/2014
WO	2013058111	A1	4/2013
WO	2013063097	A1	5/2013
WO	2018130898	A1	7/2018

OTHER PUBLICATIONS

Consumer Electronic Optics: How small a lens can be? The case of panomorph lenses, Thibault et al., Sep. 2014, 7 pages.

Optical design of camera optics for mobile phones, Steinich et al., 2012, pp. 51-58 (8 pages).

The Optics of Miniature Digital Camera Modules, Bateau et al., 2006, 11 pages.

Modeling and measuring liquid crystal tunable lenses, Peter P. Clark, 2014, 7 pages.

Mobile Platform Optical Design, Peter P. Clark, 2014, 7 pages.

Boye et al., "Ultrathin Optics for Low-Profile Innocuous Imager", Sandia Report, 2009, pp. 56-56.

"Cheat sheet: how to understand f-stops", Internet article, Digital Camera World, 2017.

* cited by examiner

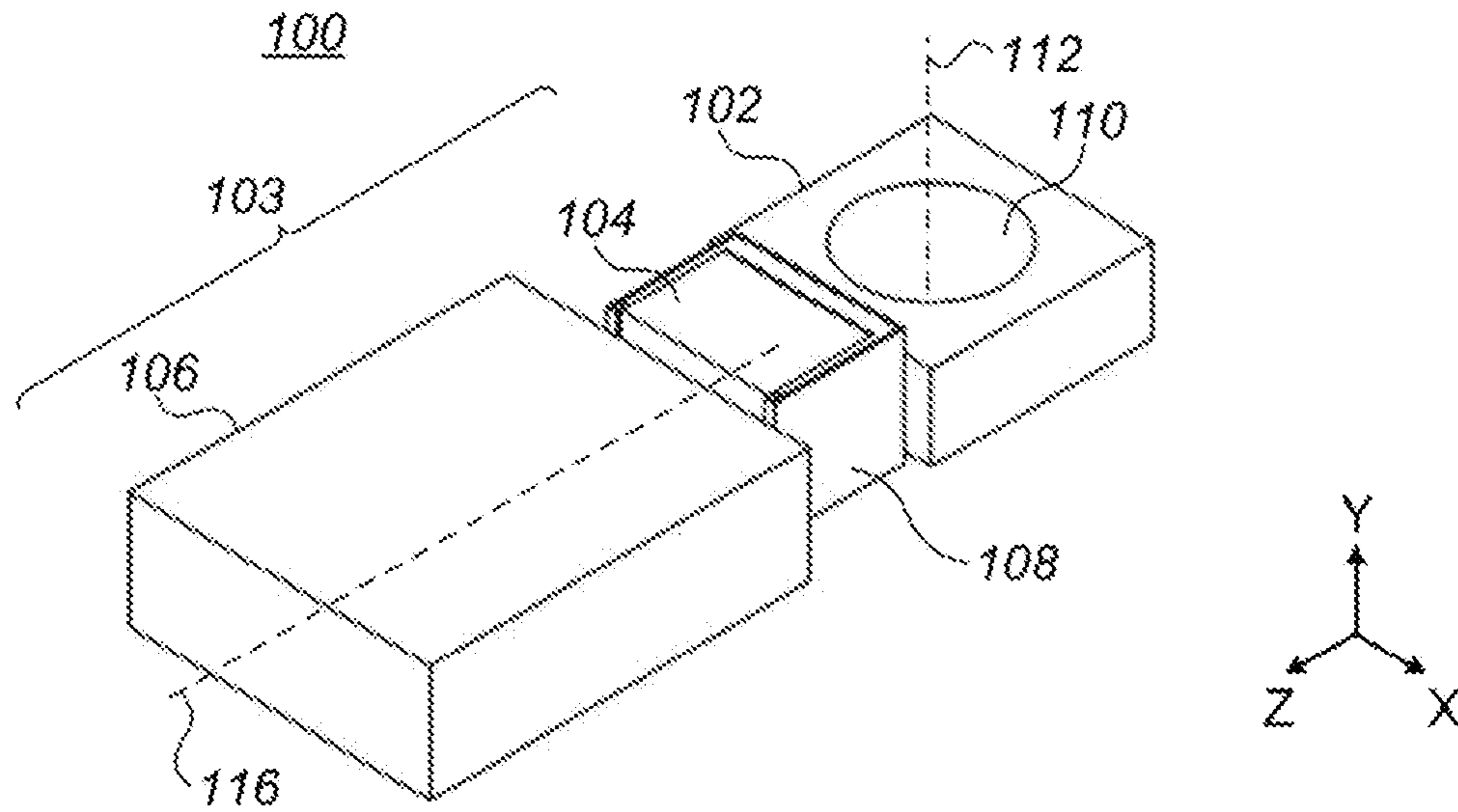

FIG. 1A

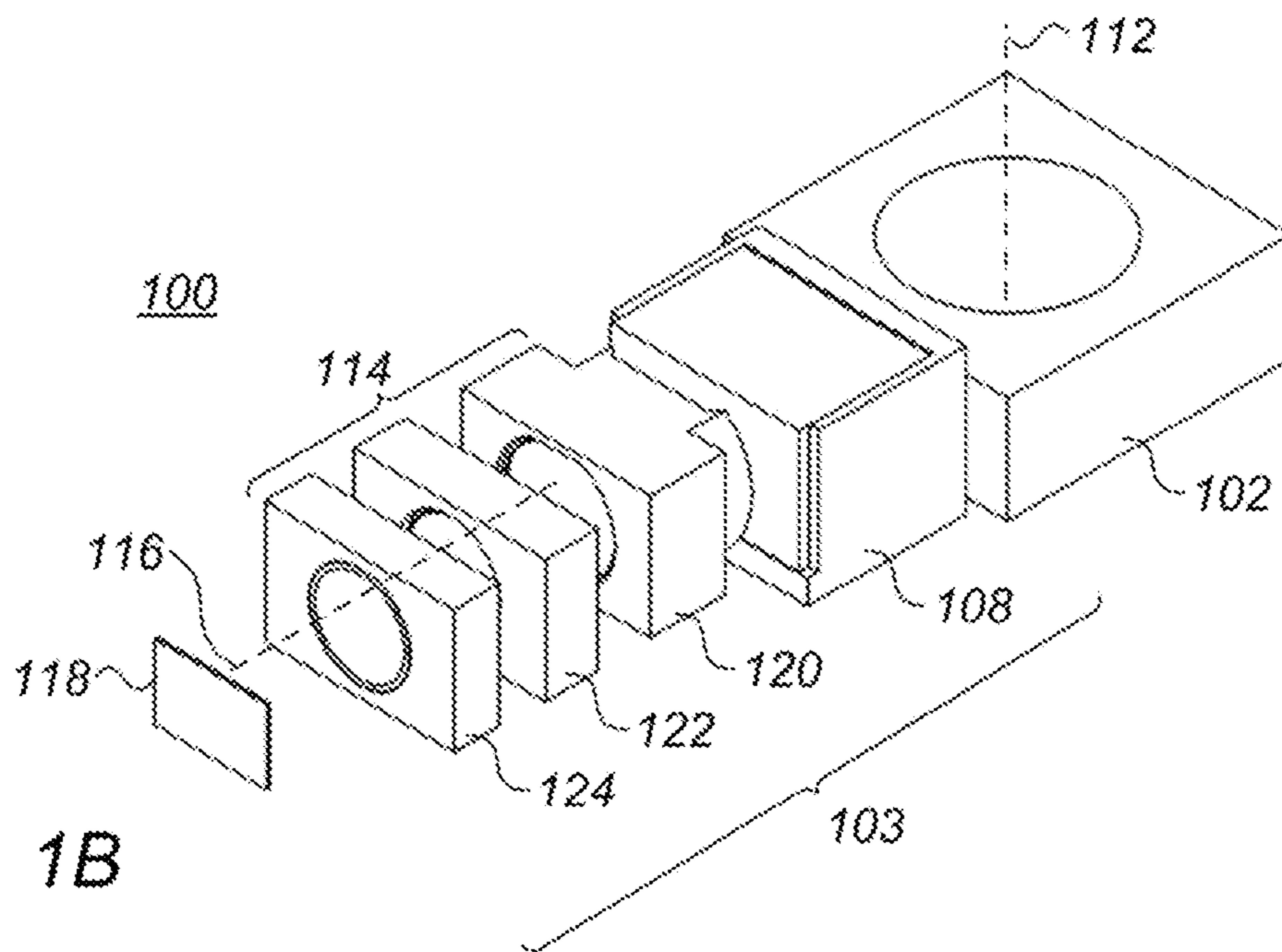

FIG. 1B

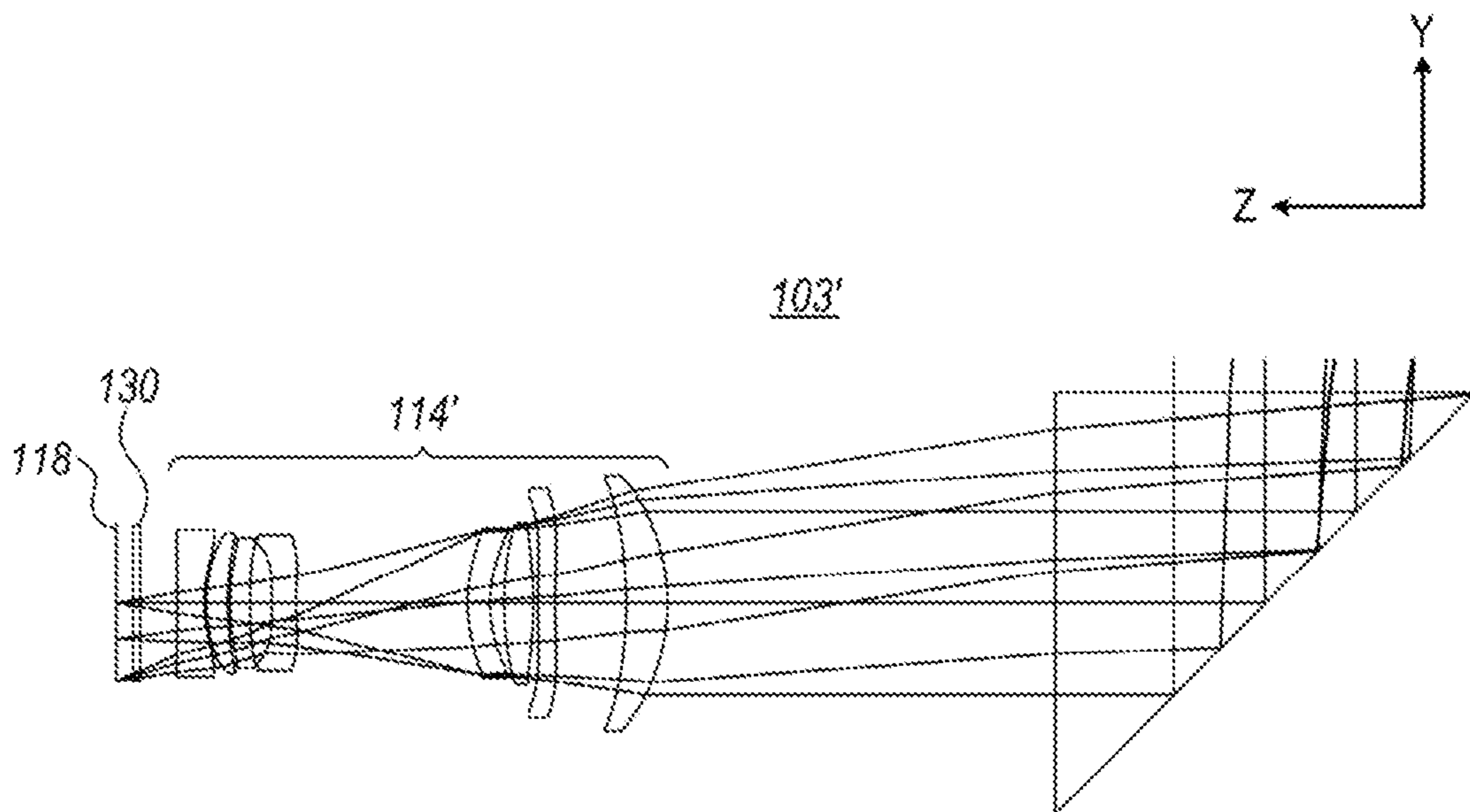

FIG. 2A

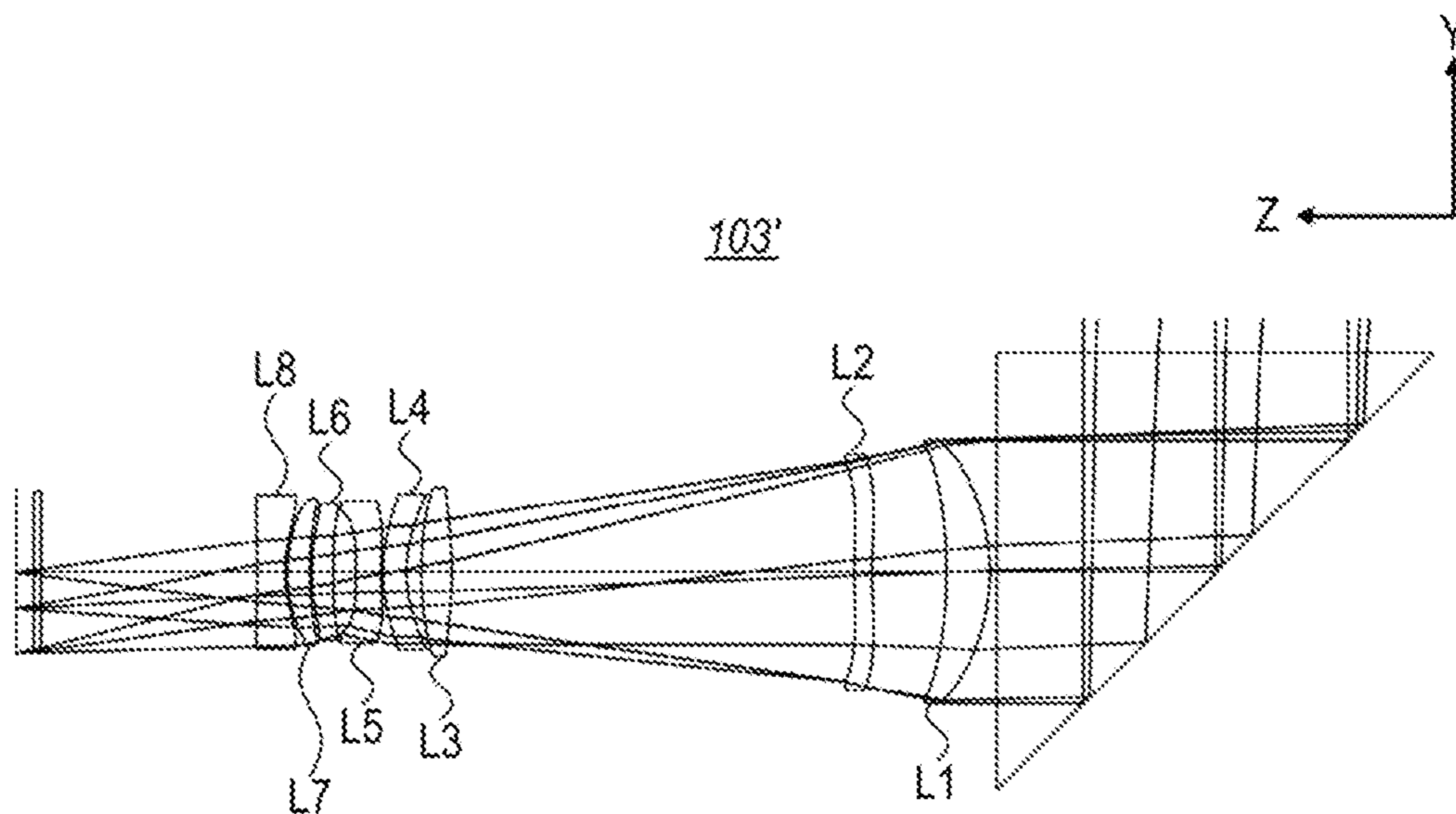

FIG. 2B

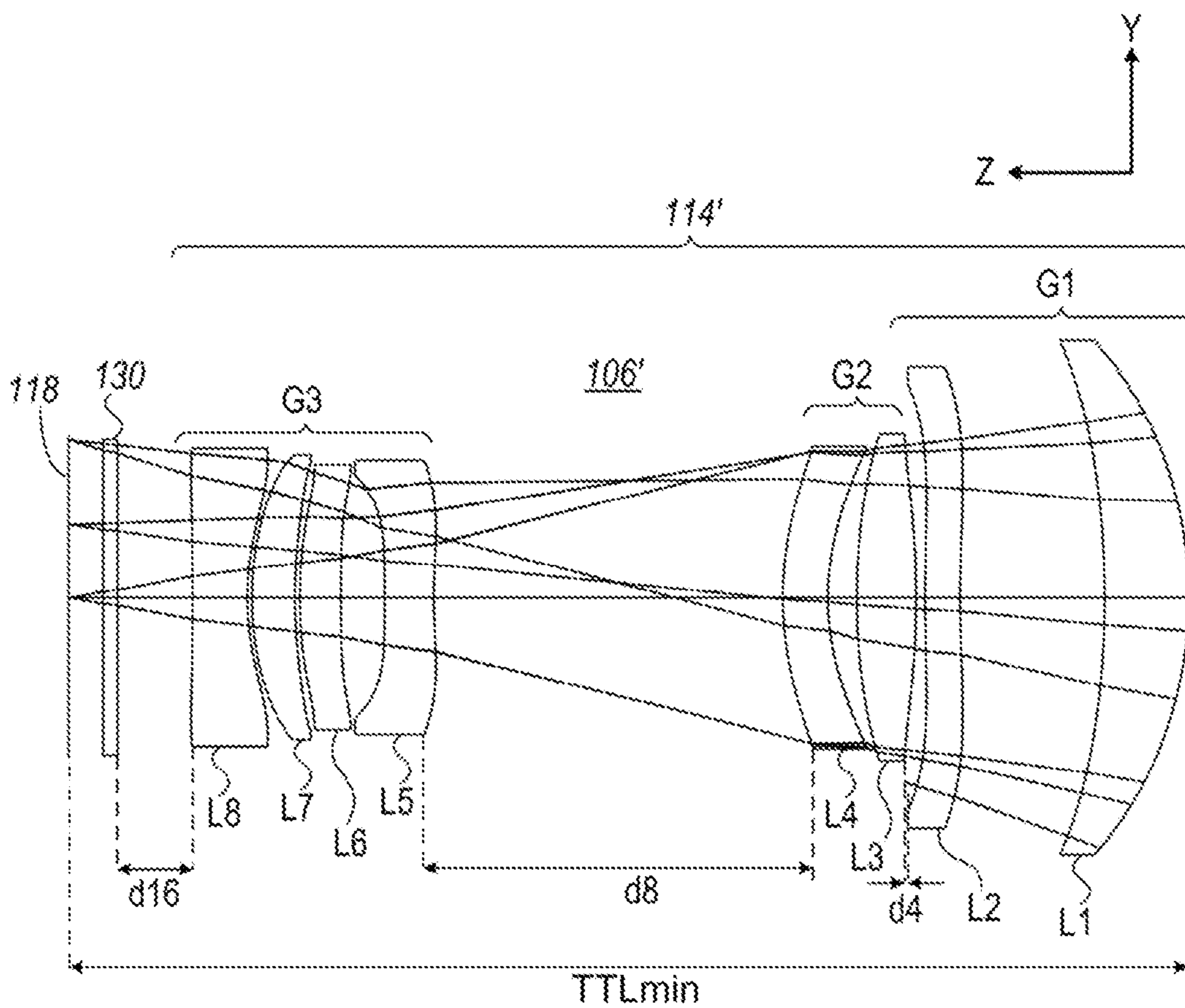

FIG. 2C

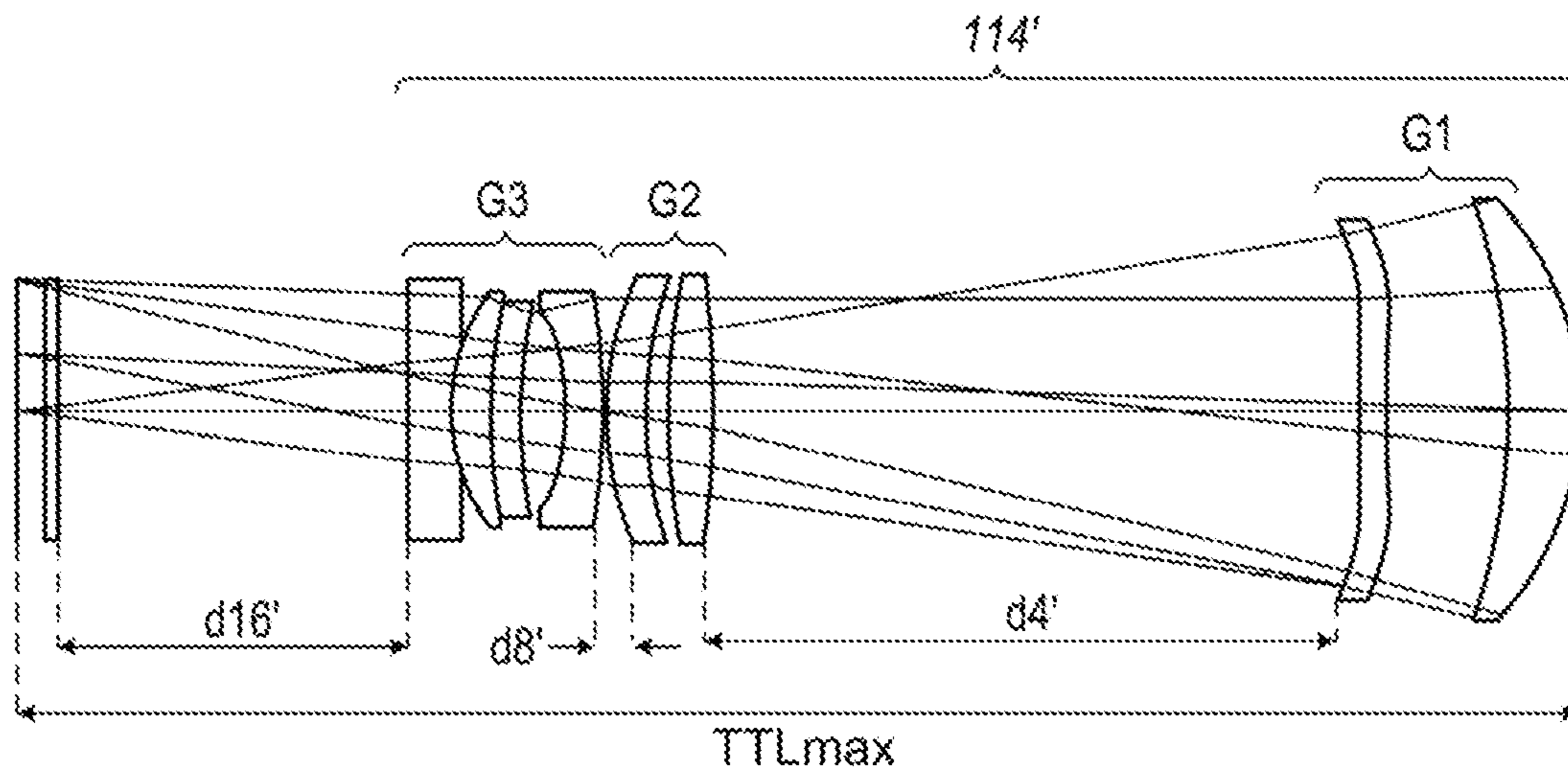

FIG. 2D

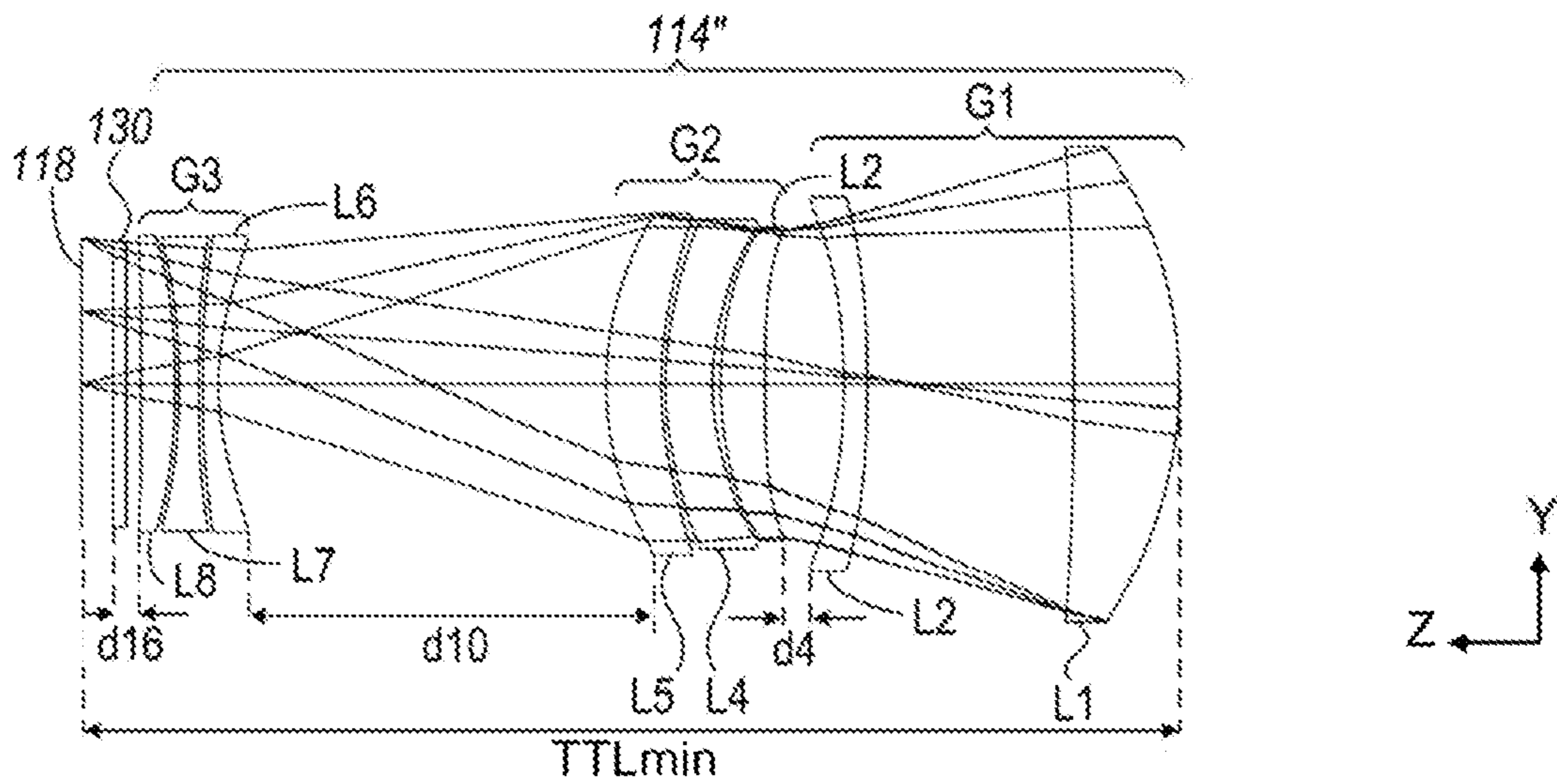
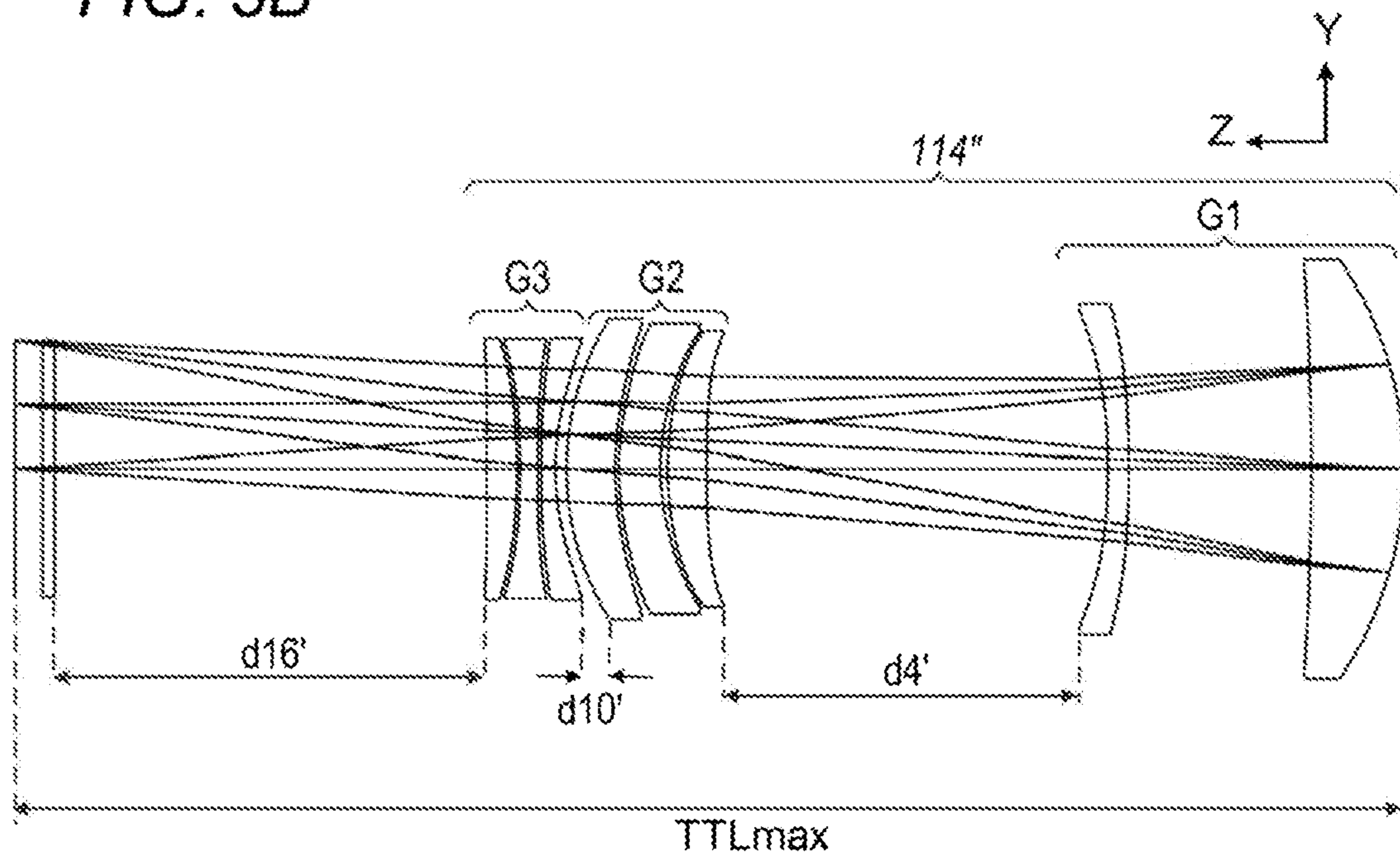

FIG. 3A

FIG. 3B



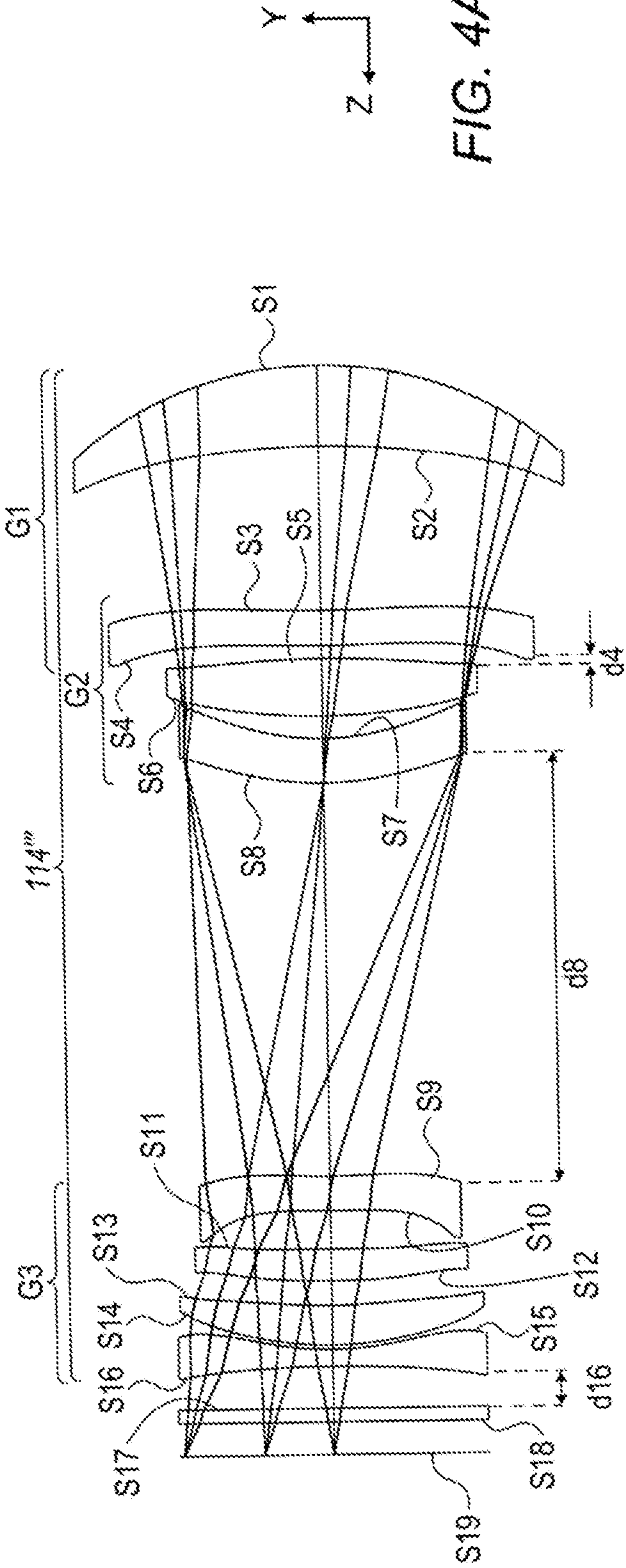

FIG. 4A

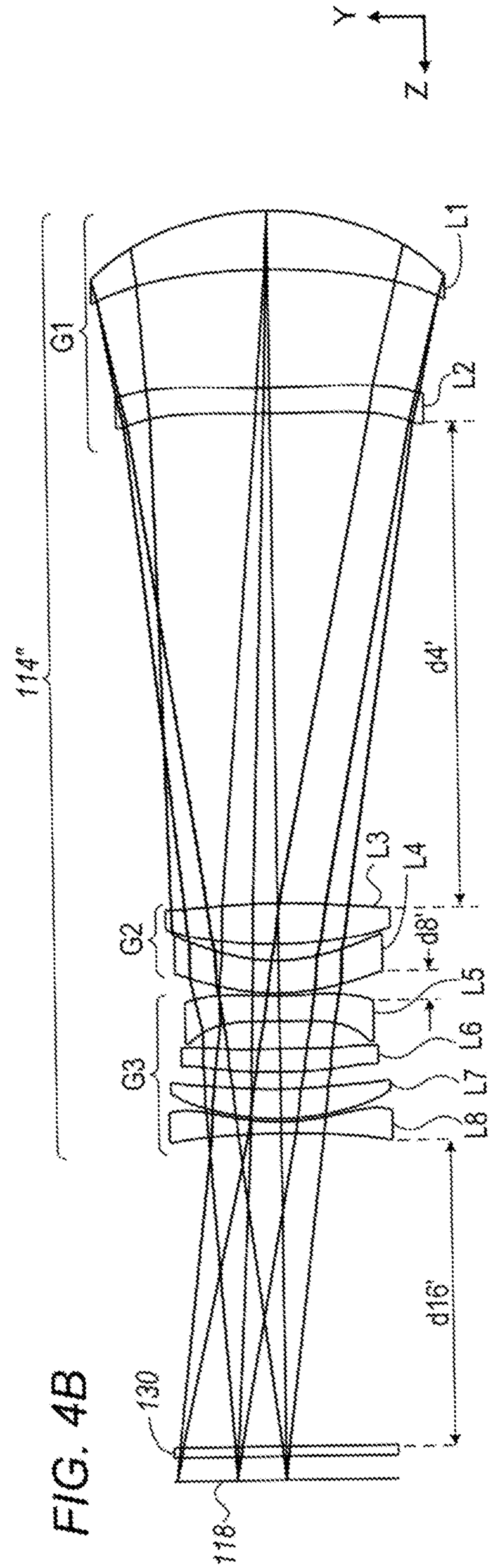

FIG. 4B

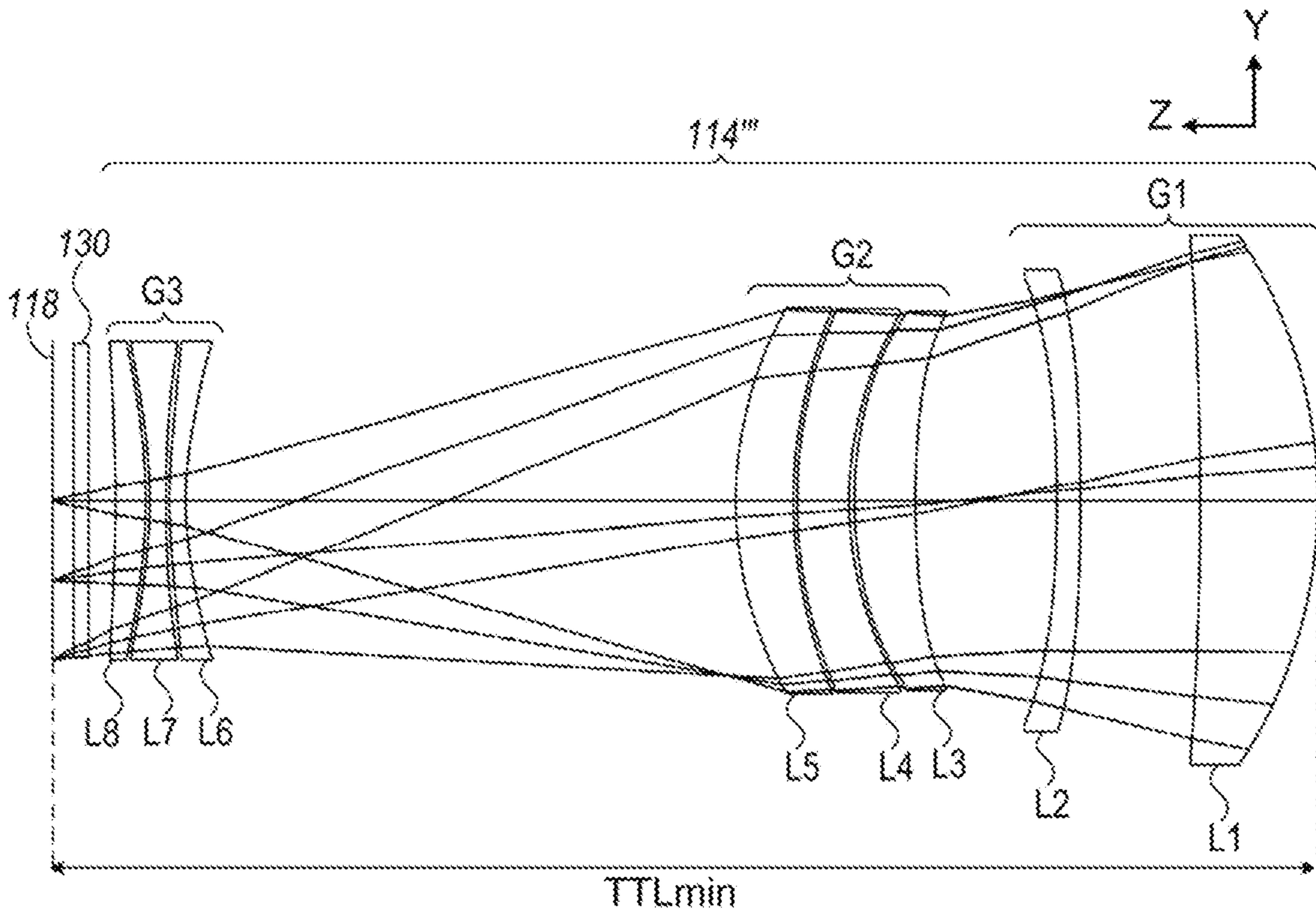

FIG. 4C

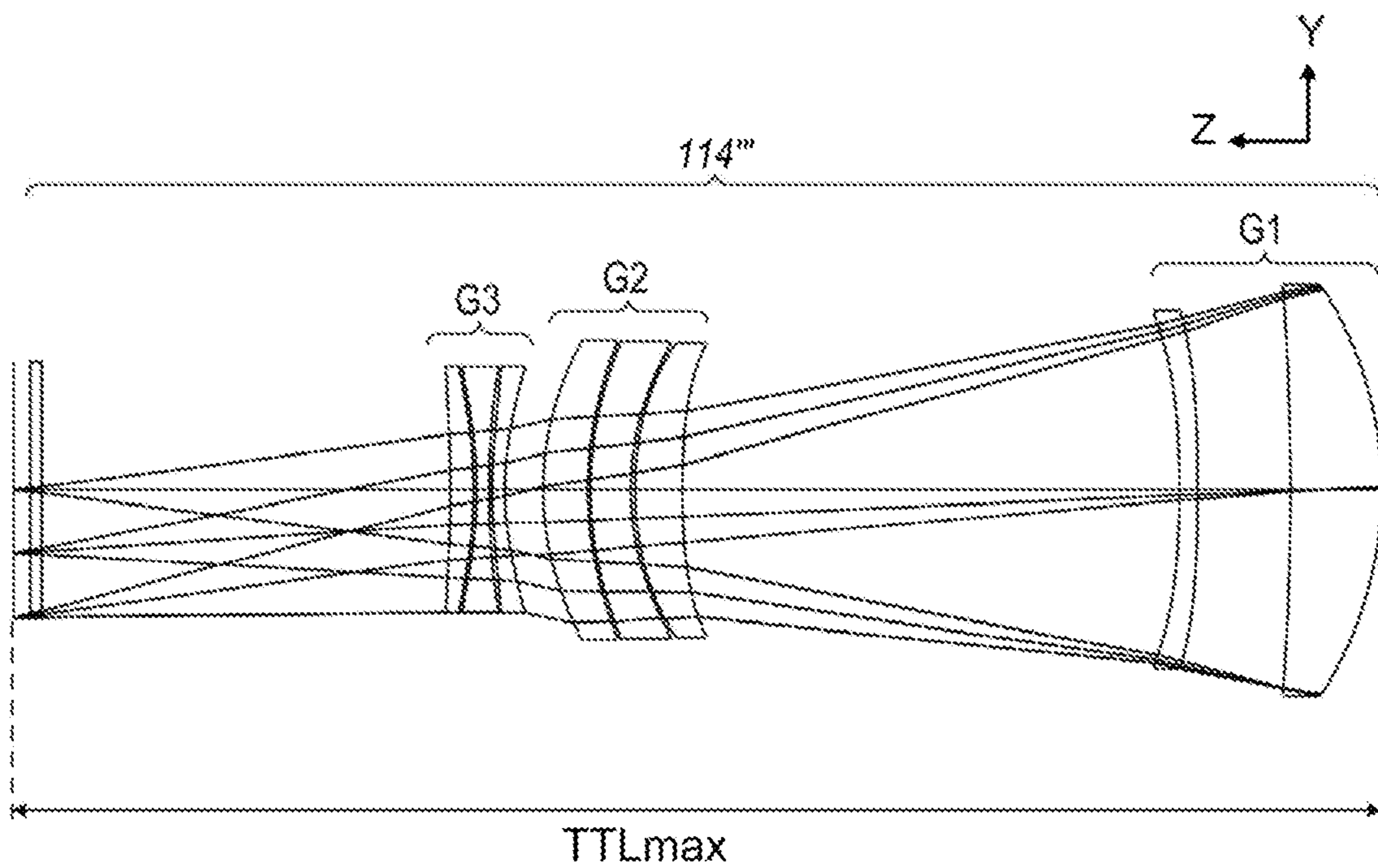

FIG. 4D

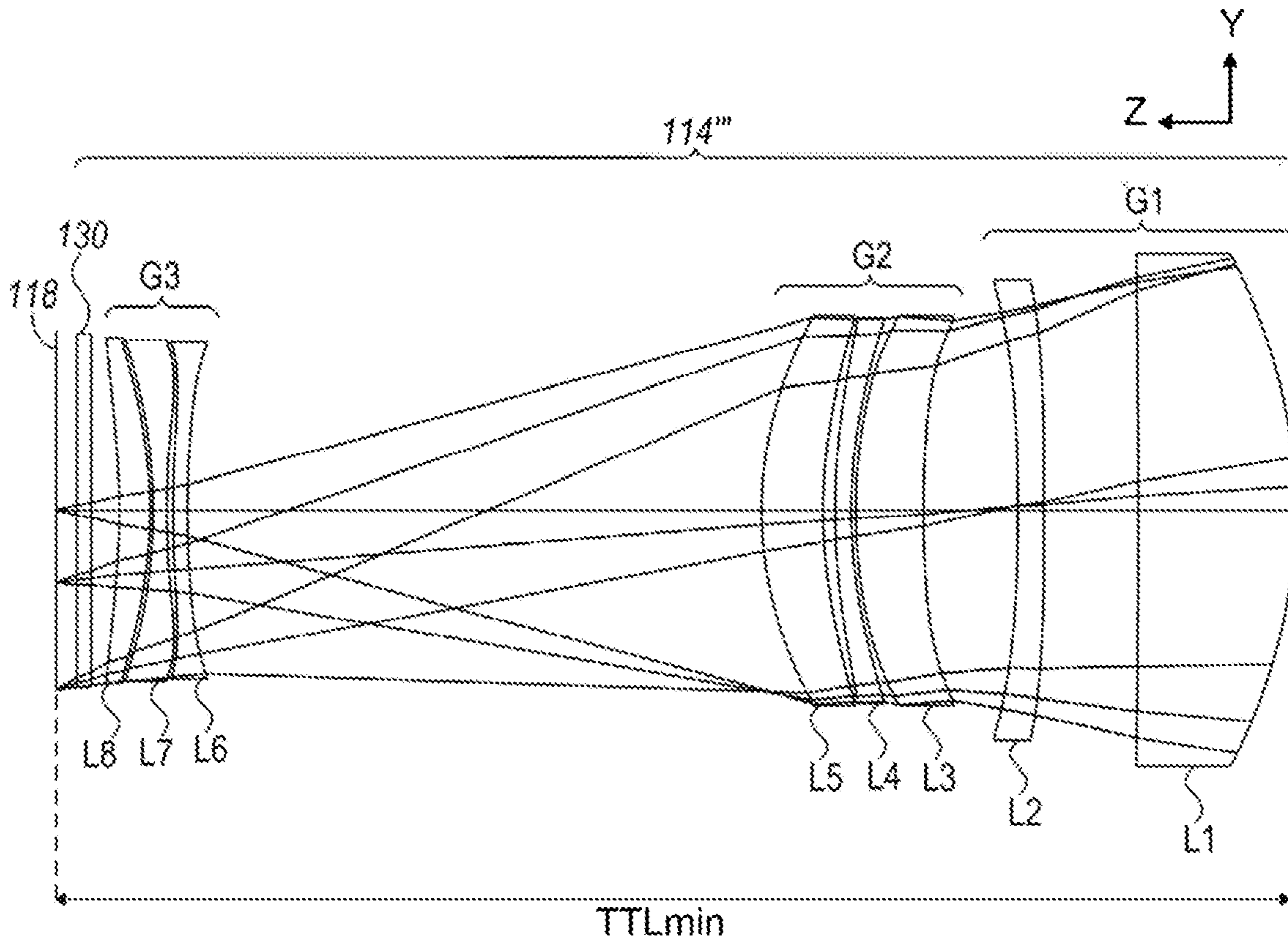

FIG. 4E

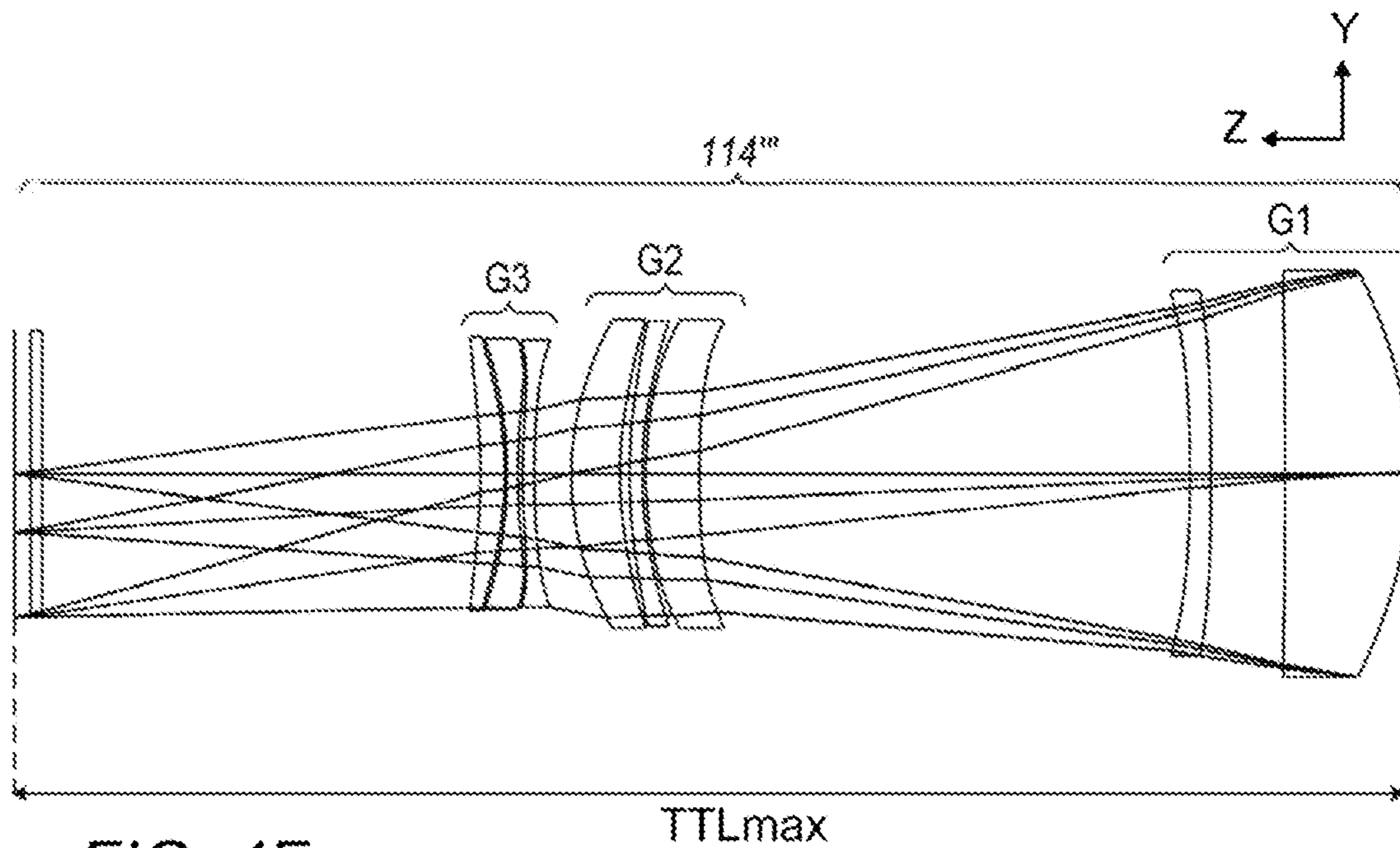

FIG. 4F

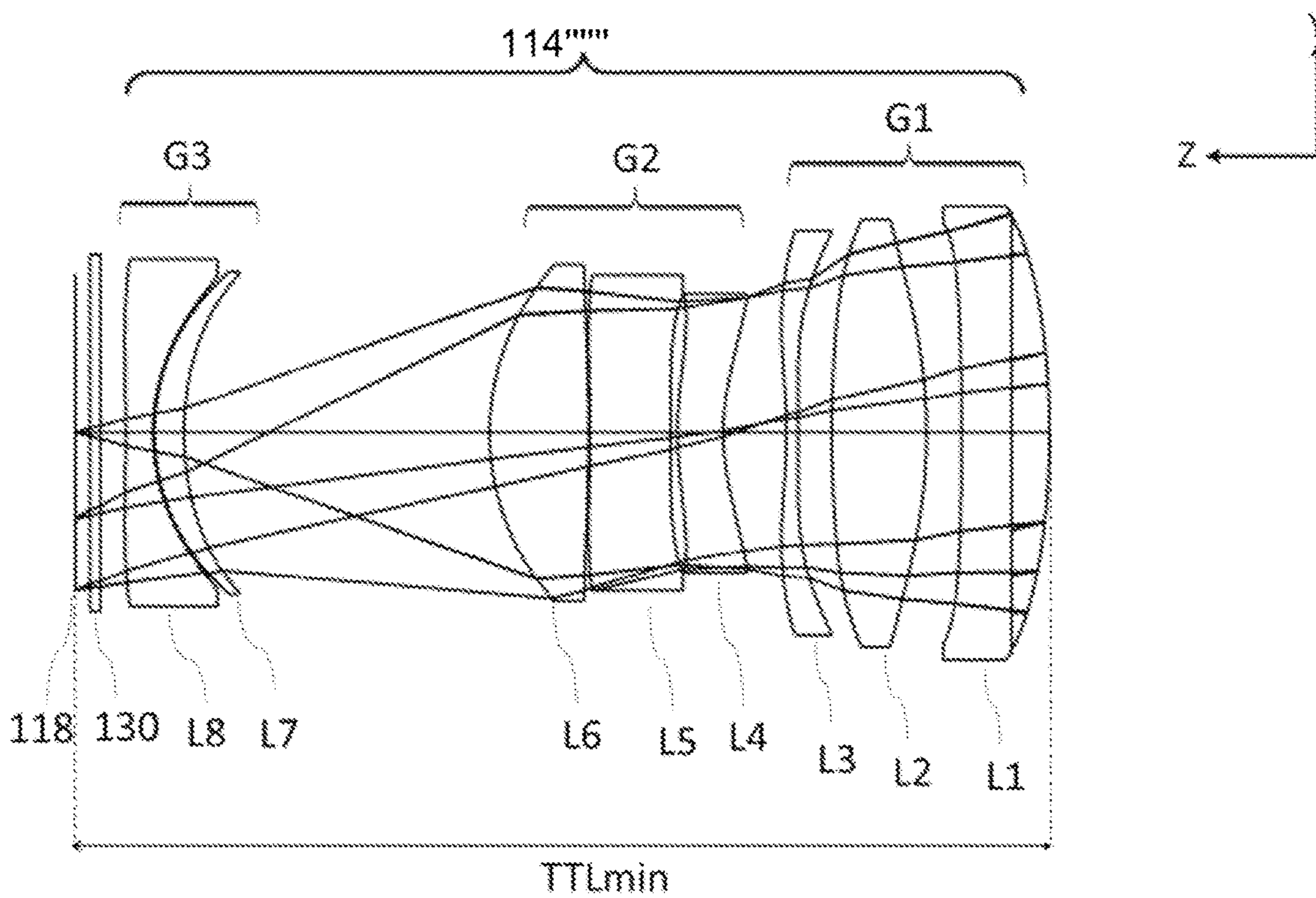

FIG. 4G

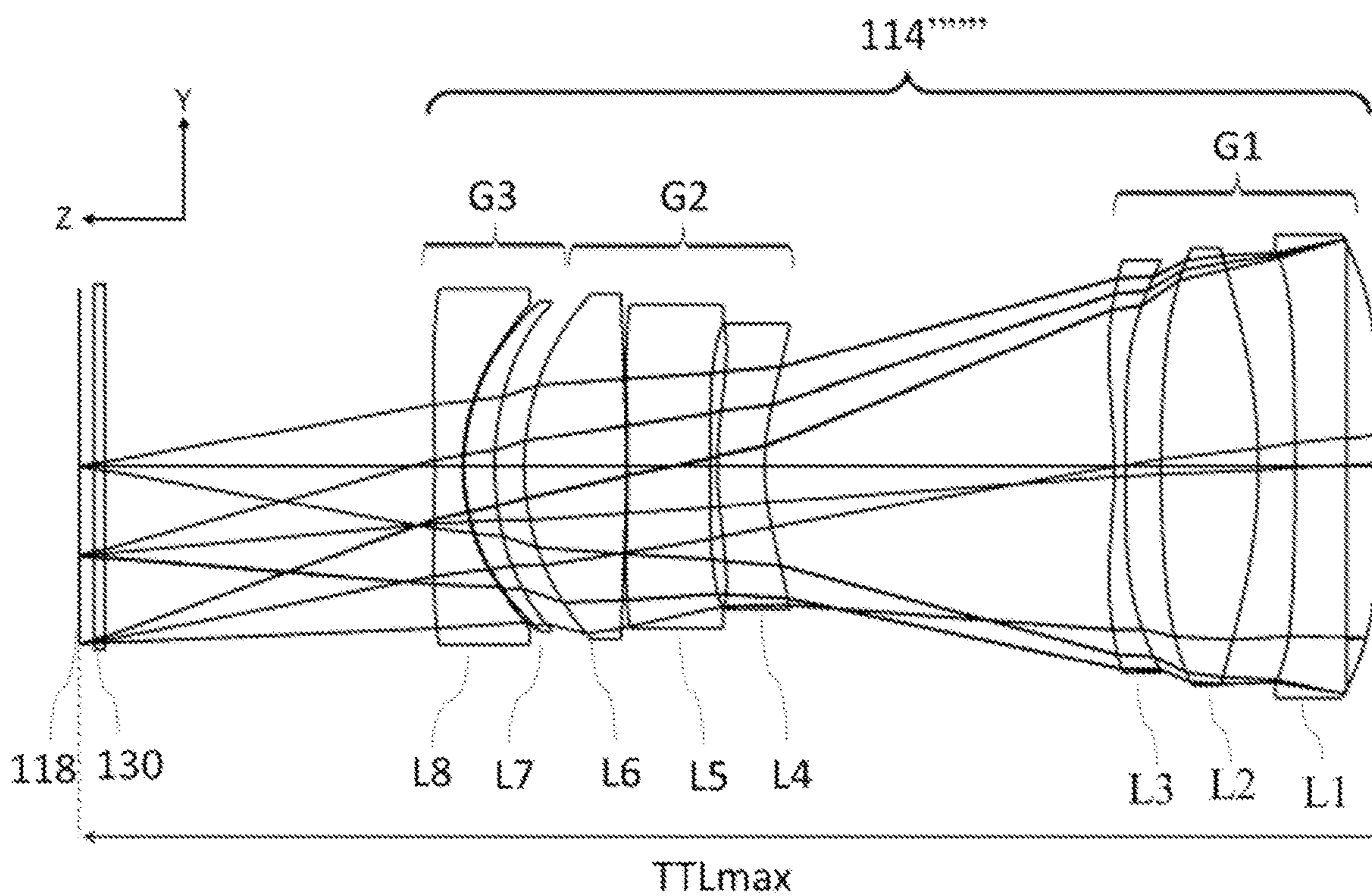

FIG. 4H

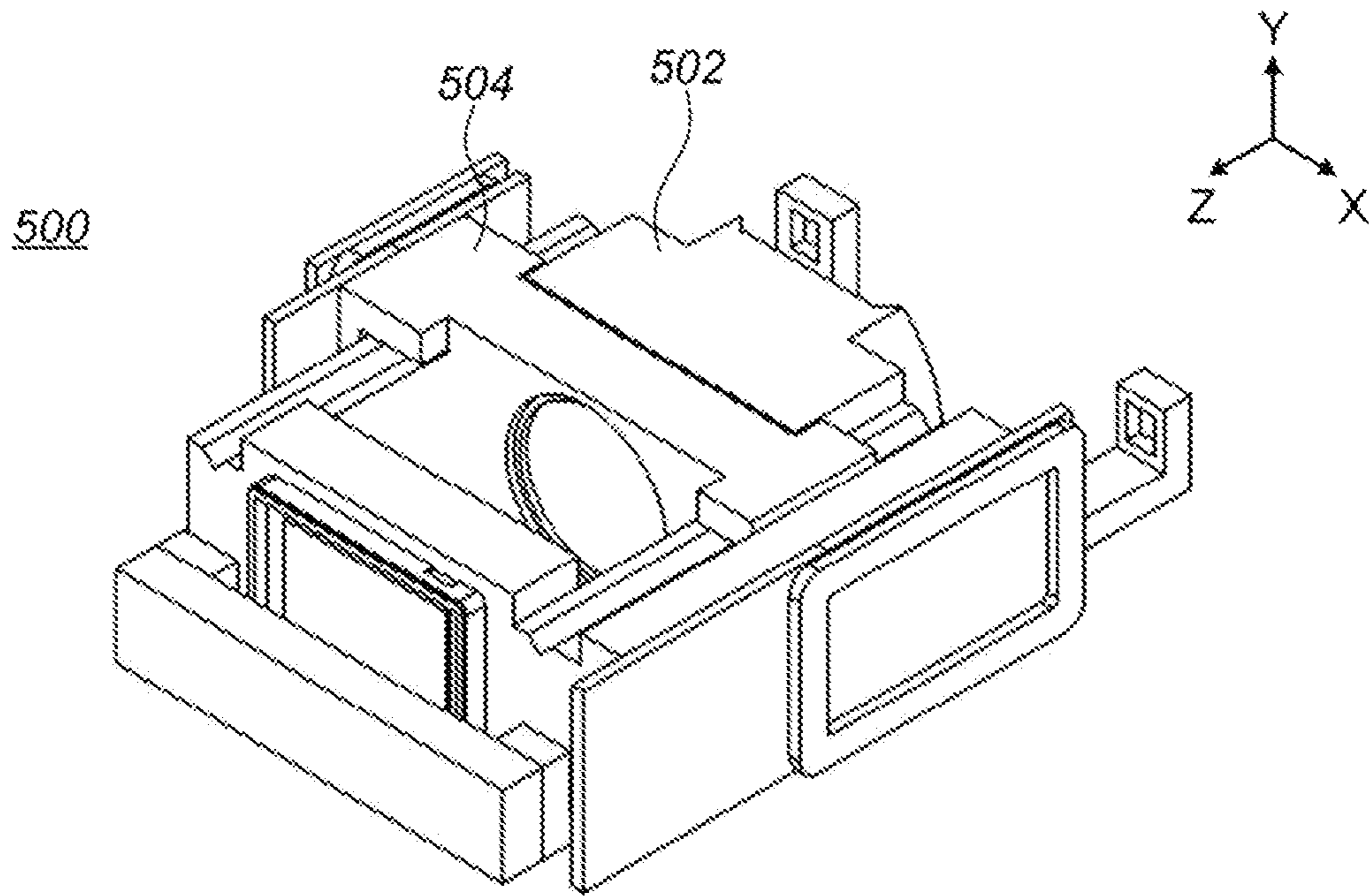

FIG. 5A

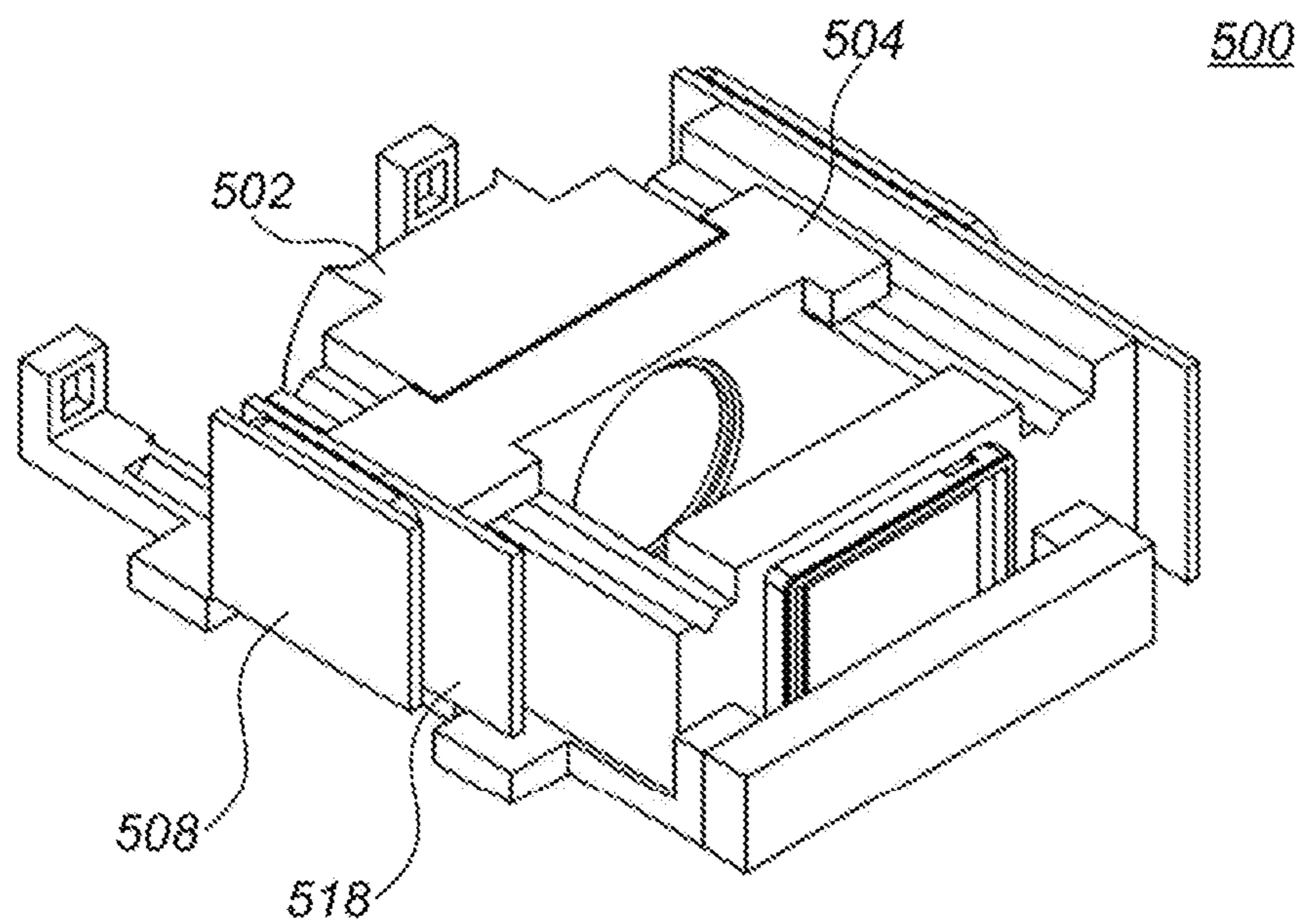

FIG. 5B

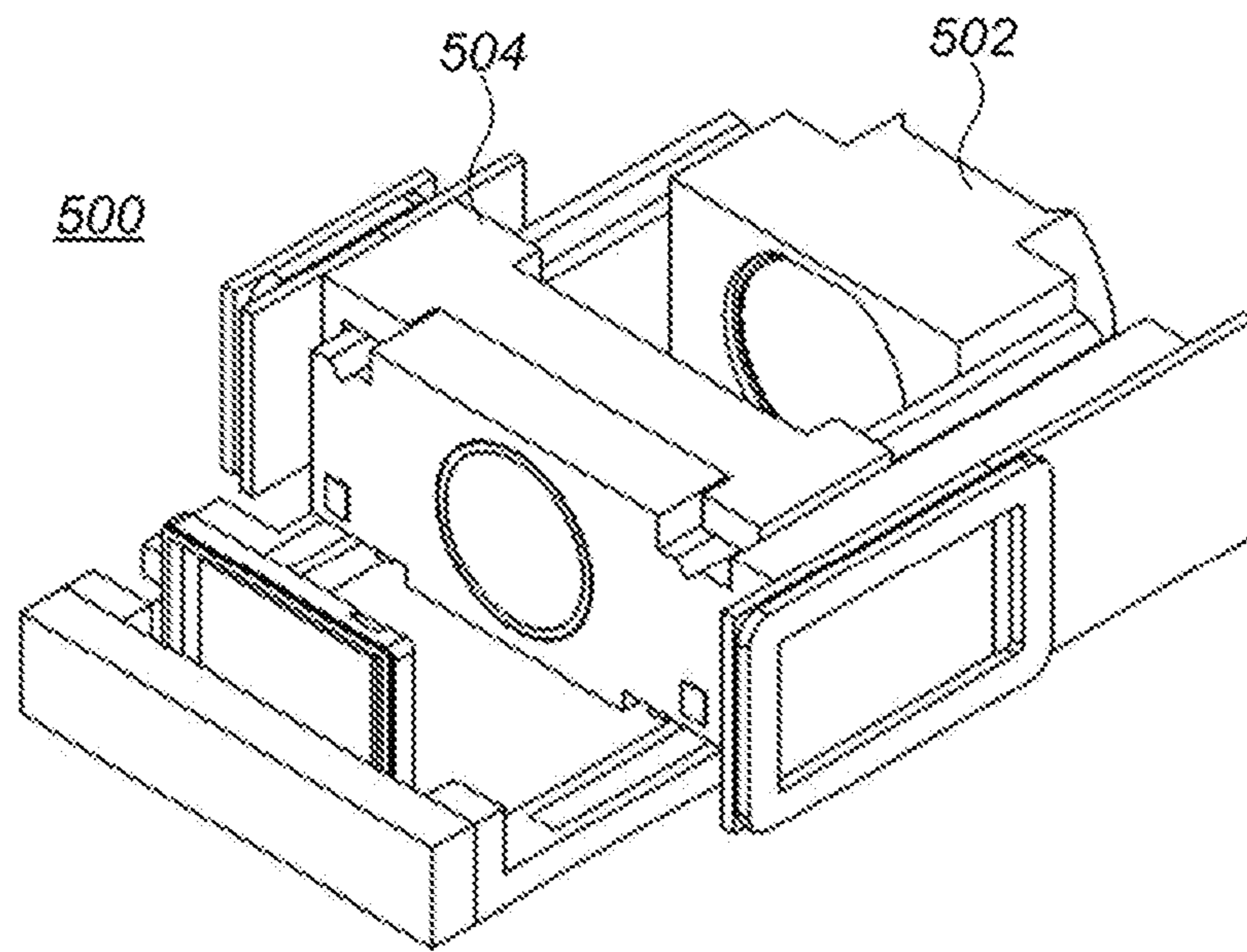

FIG. 5C

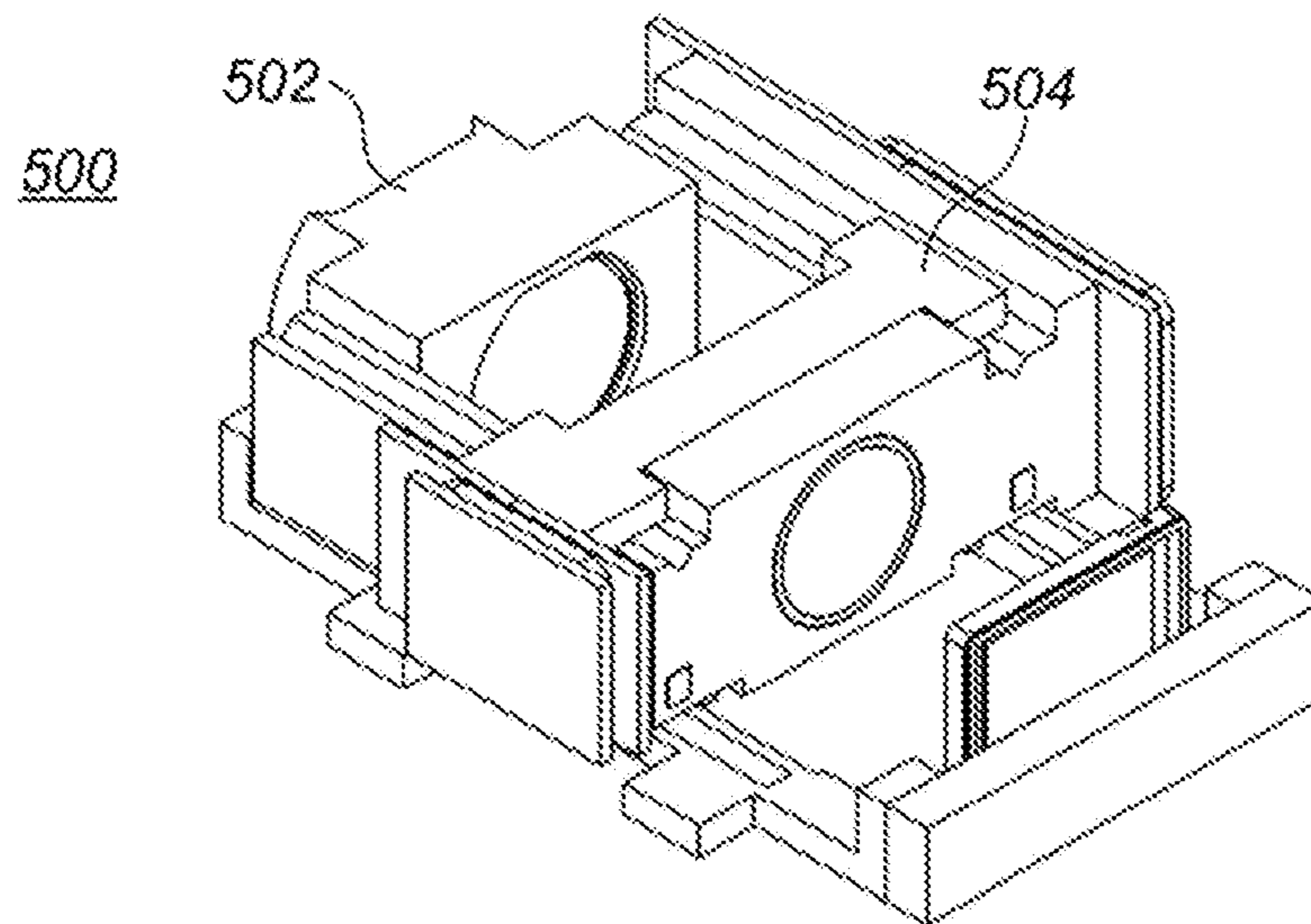

FIG. 5D

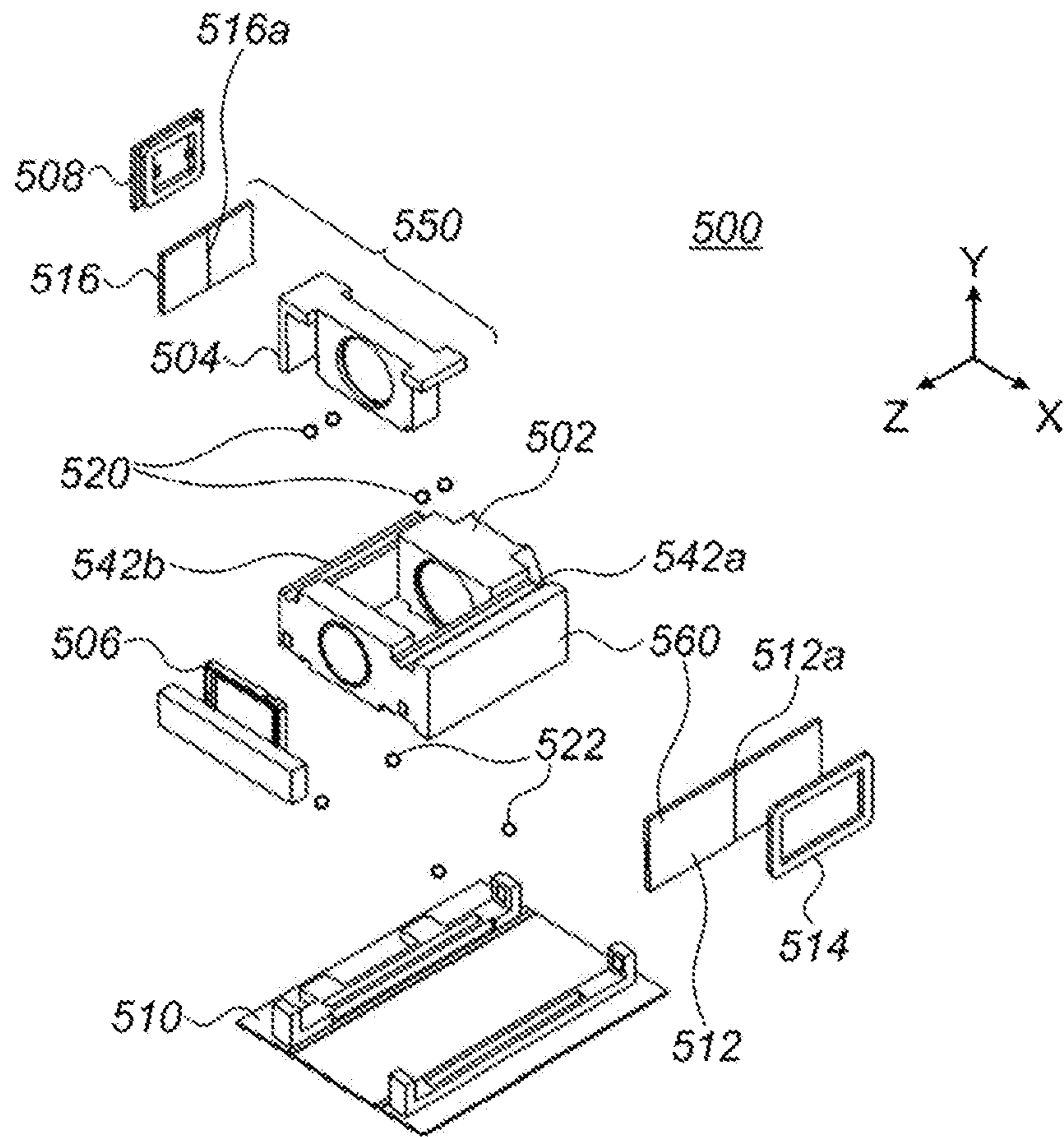

FIG. 5E

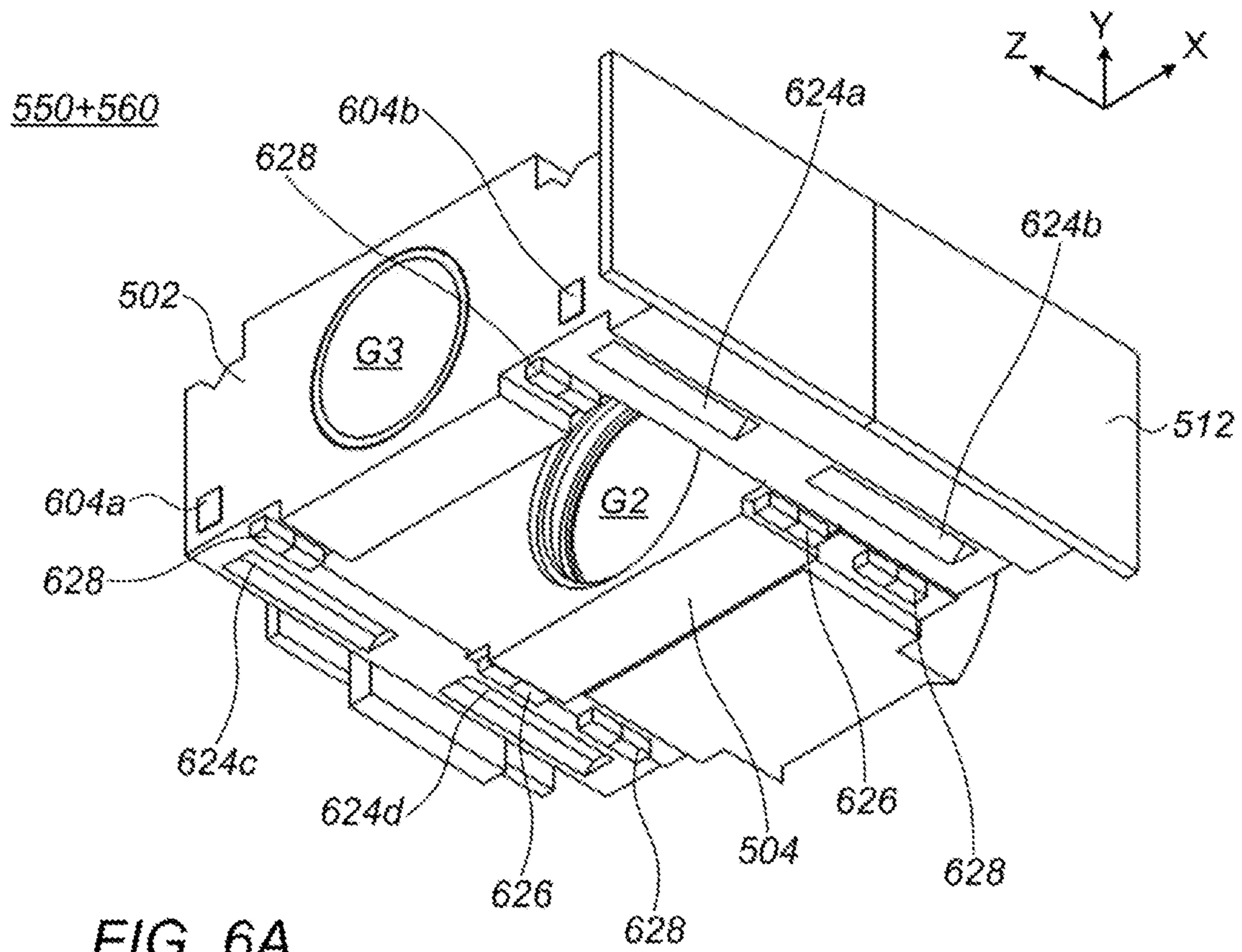

FIG. 6A

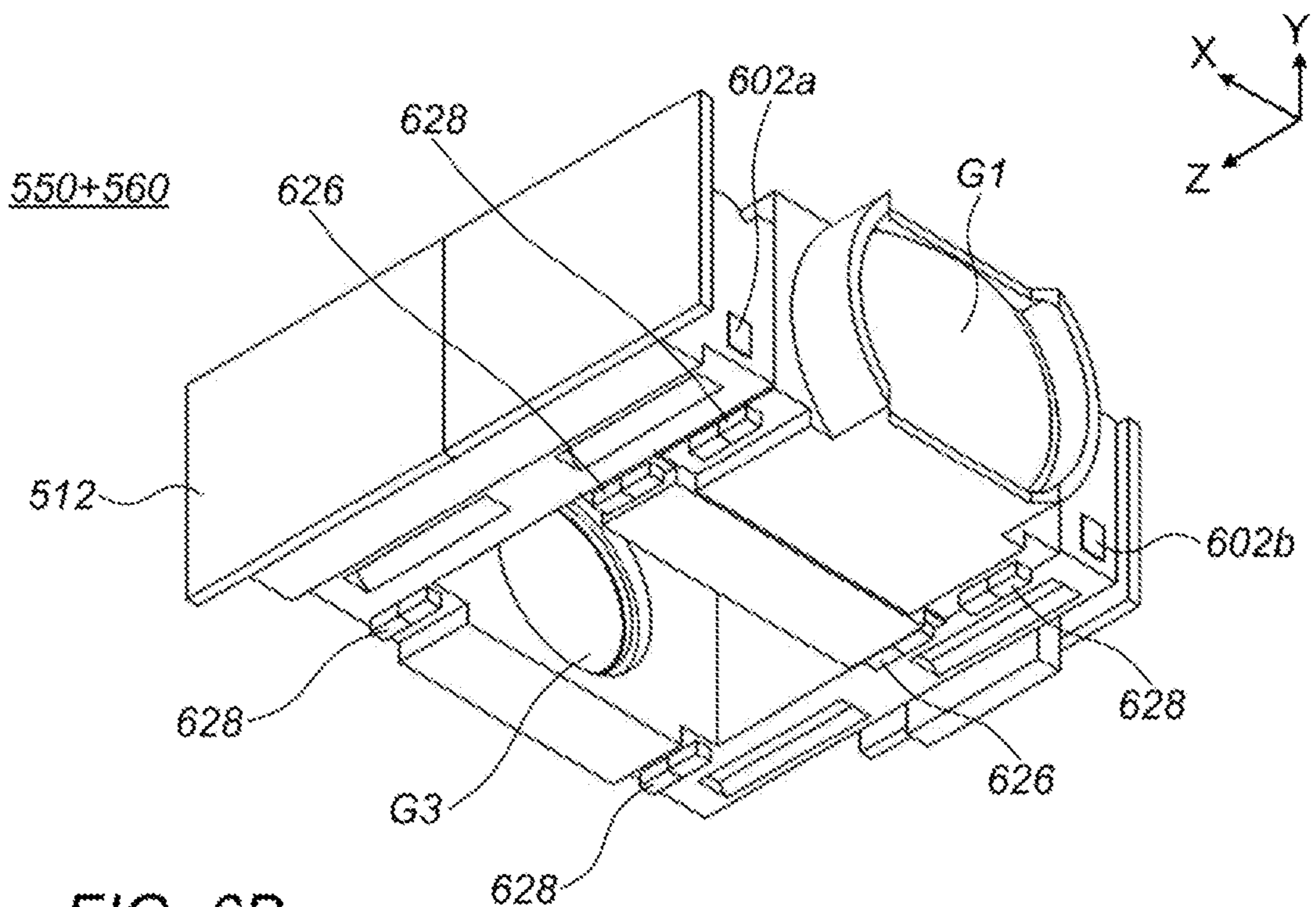
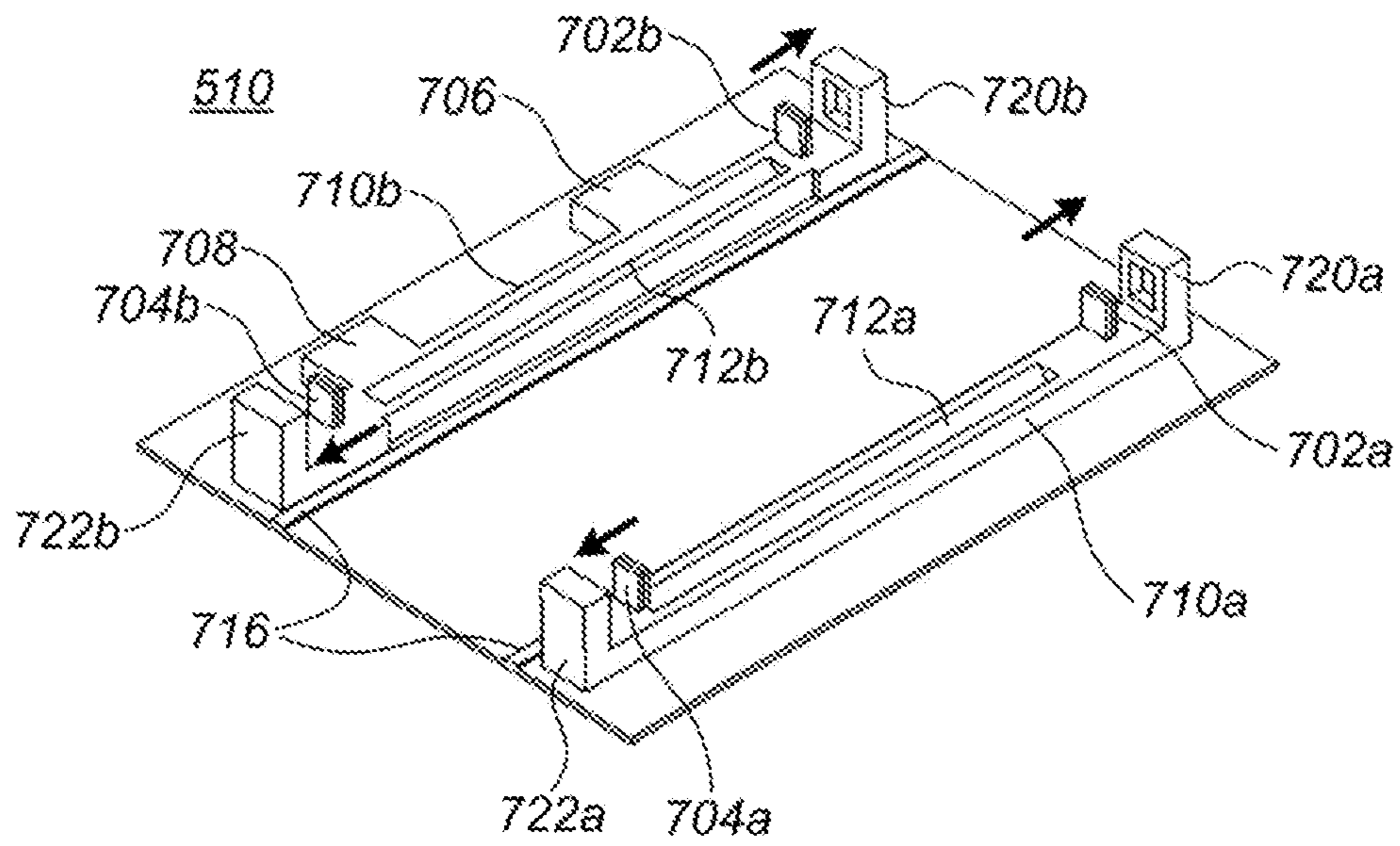
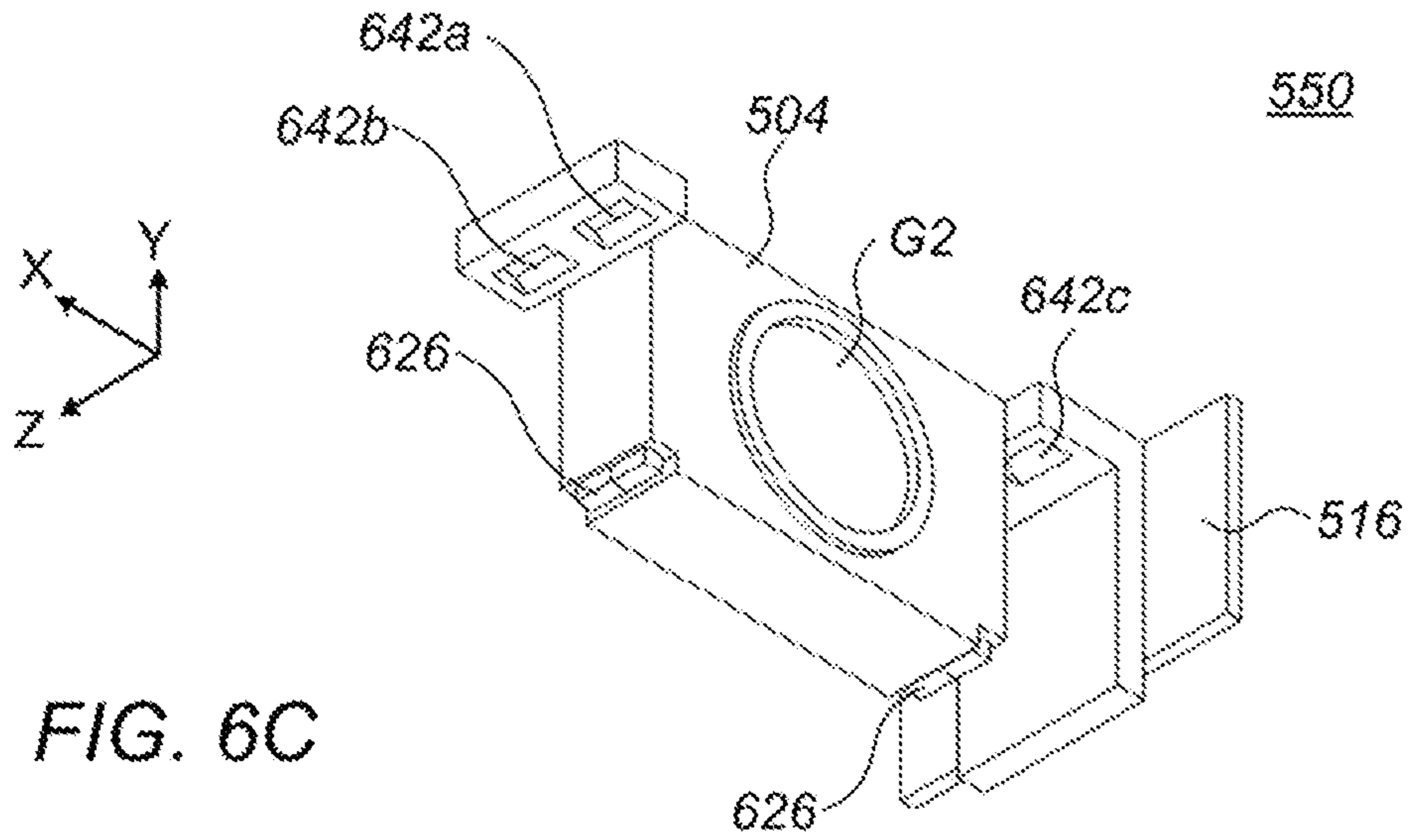

FIG. 6B



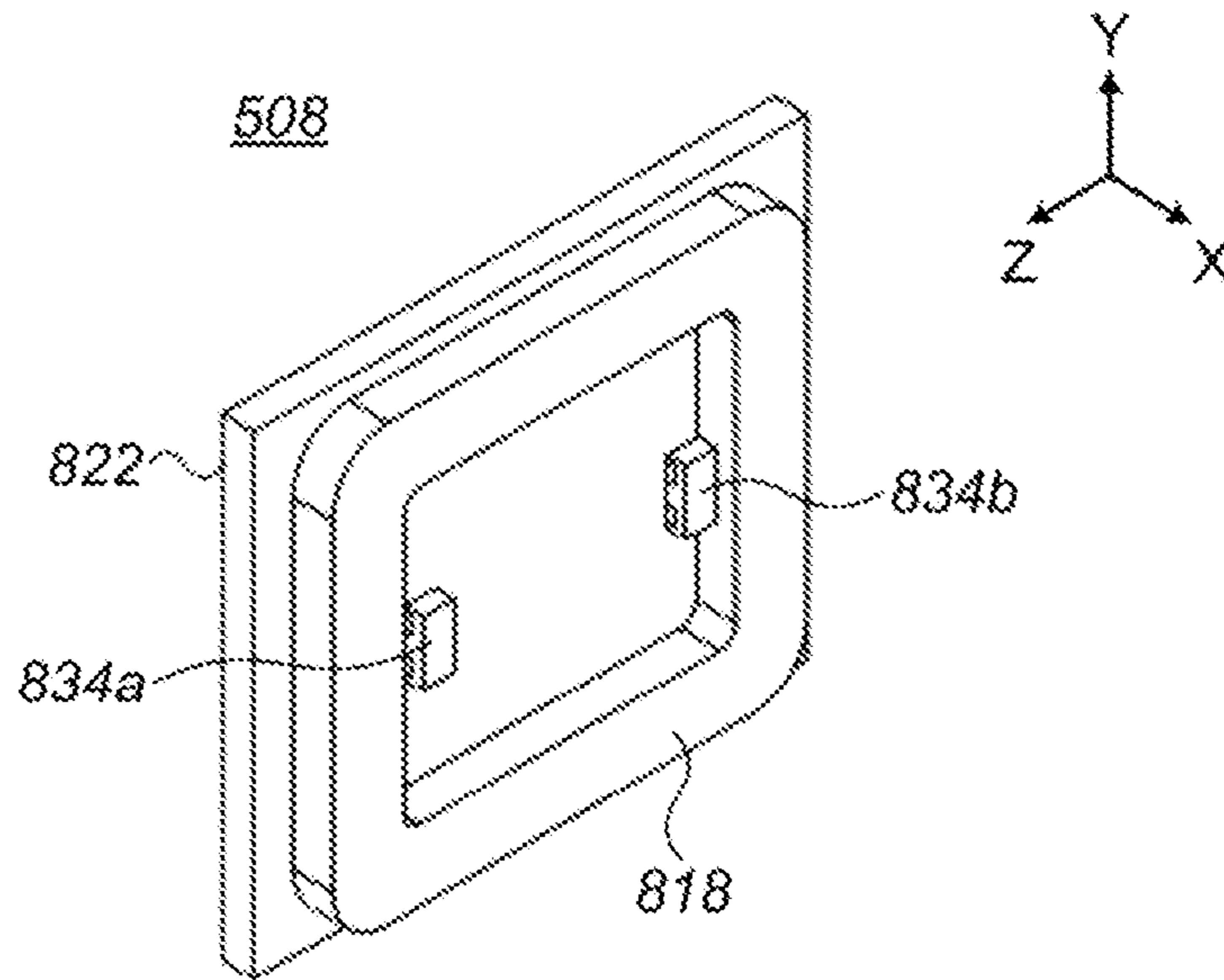

FIG. 8

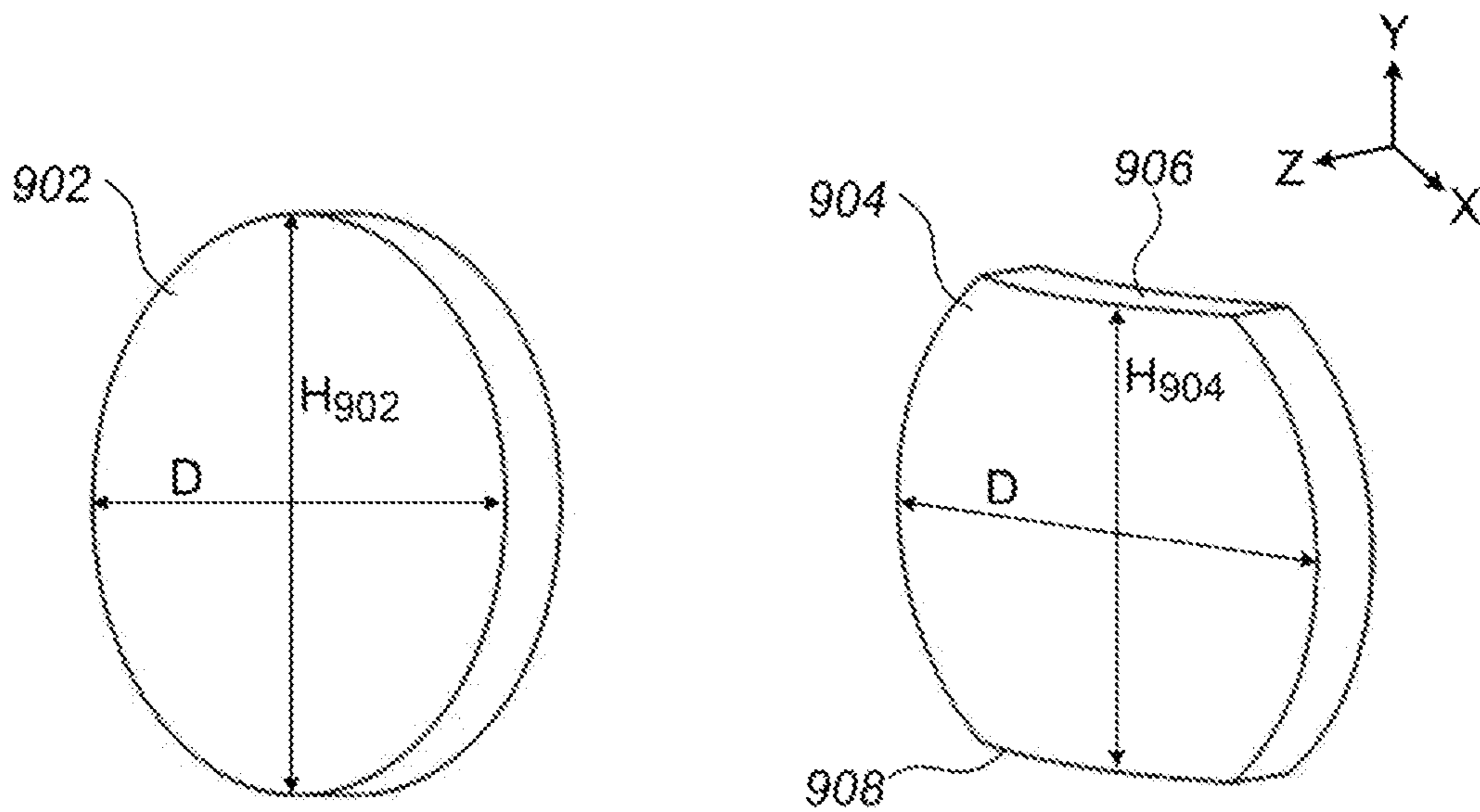

FIG. 9A

FIG. 9B

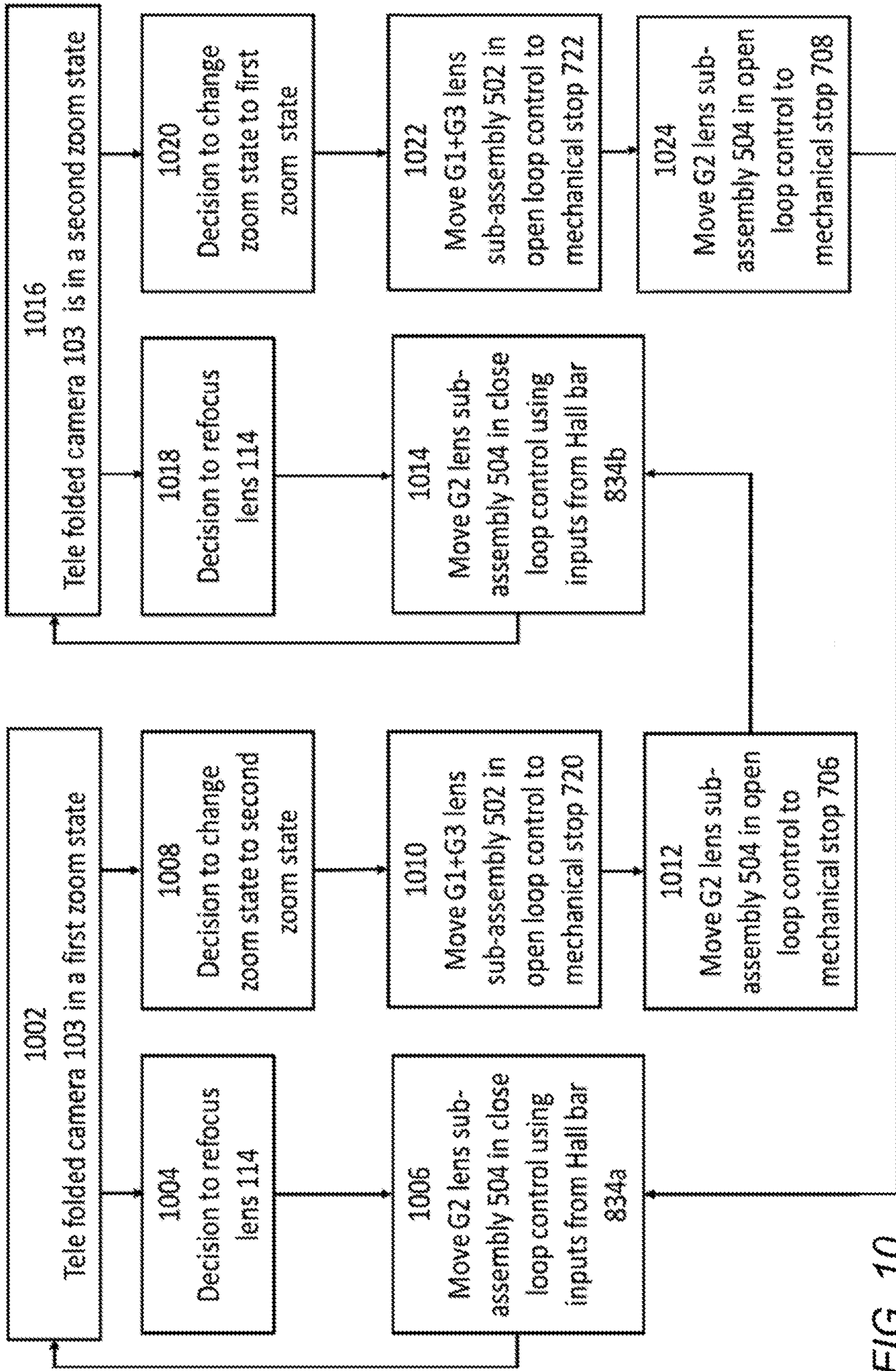
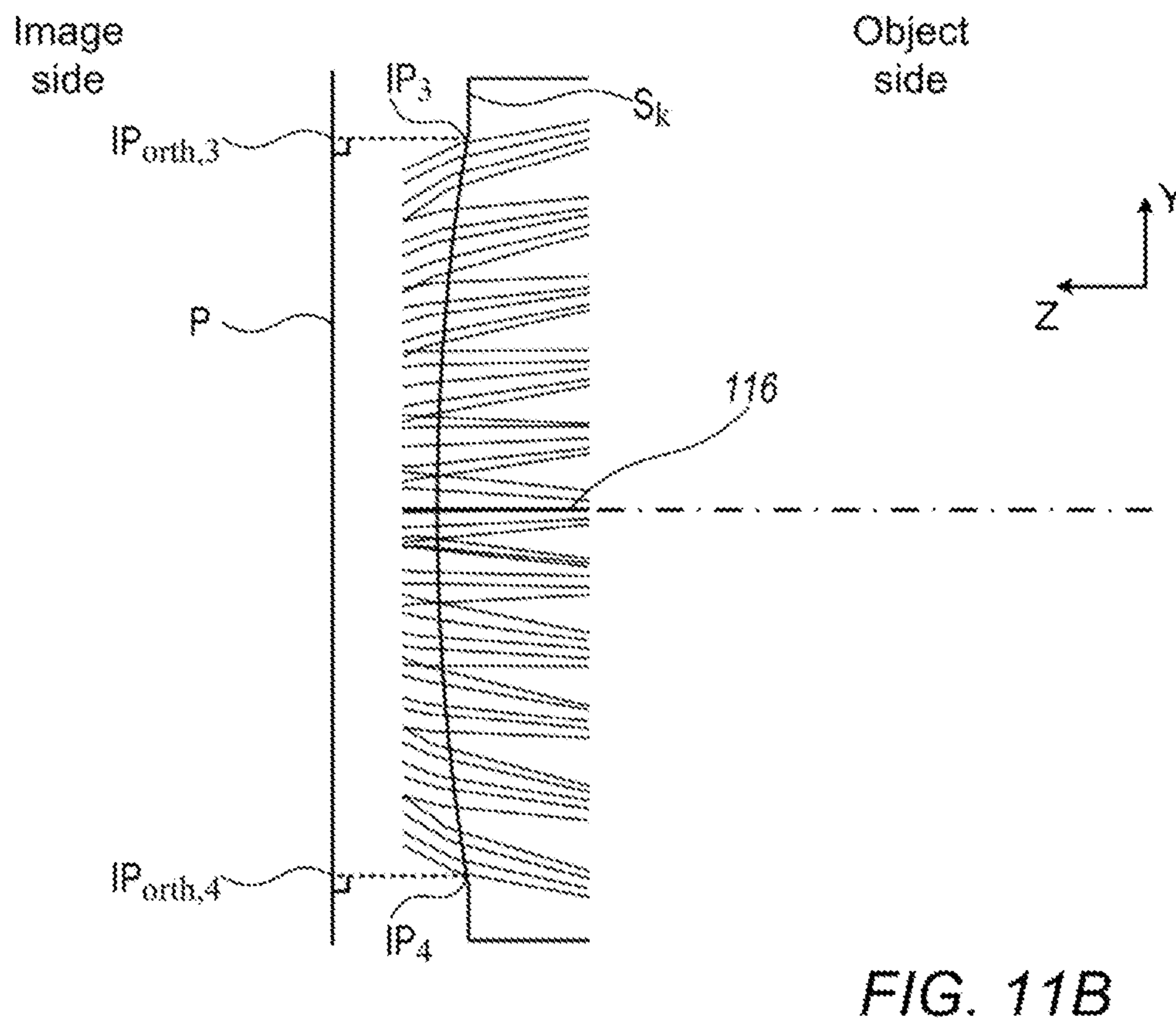
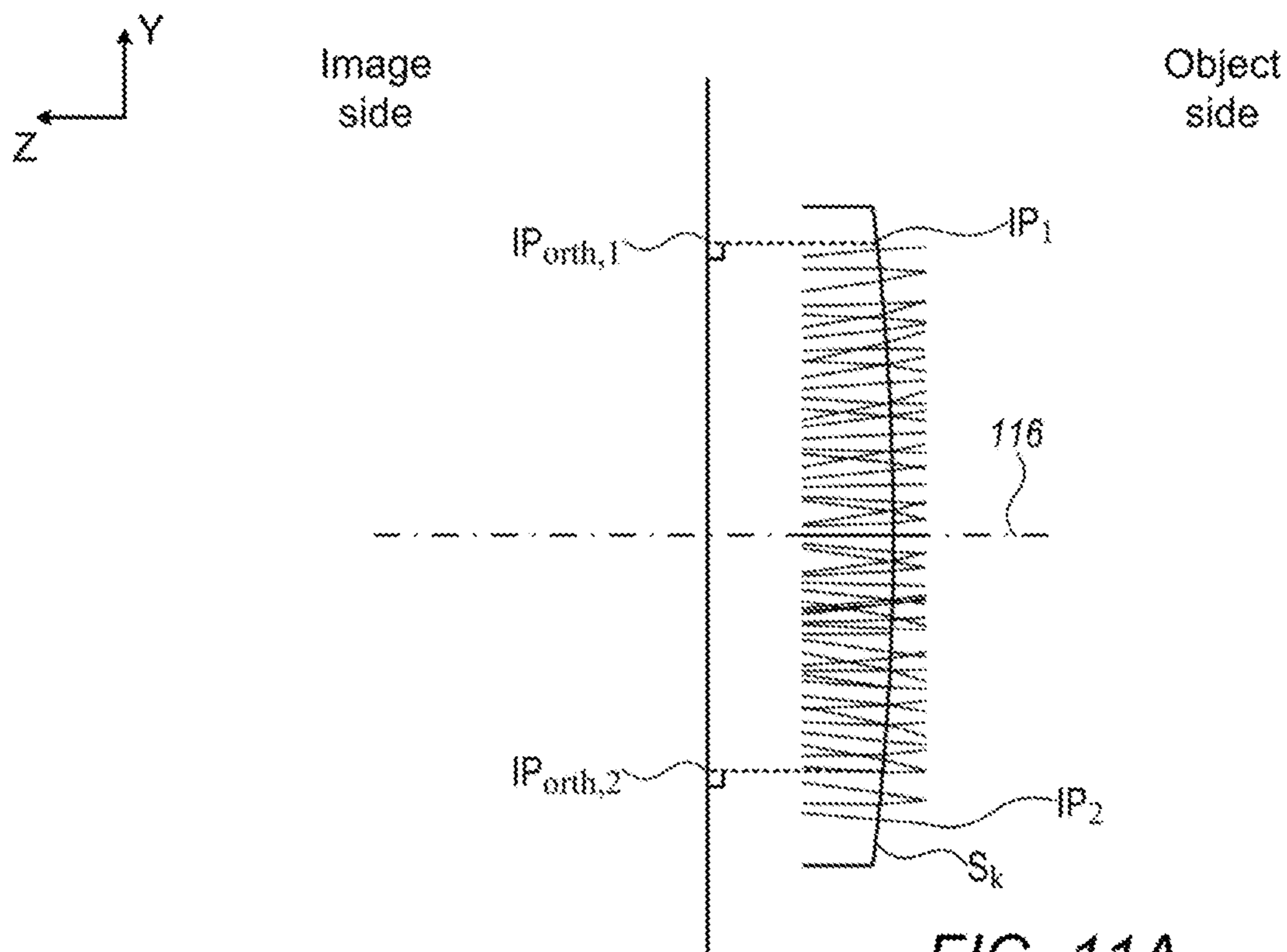

FIG. 10



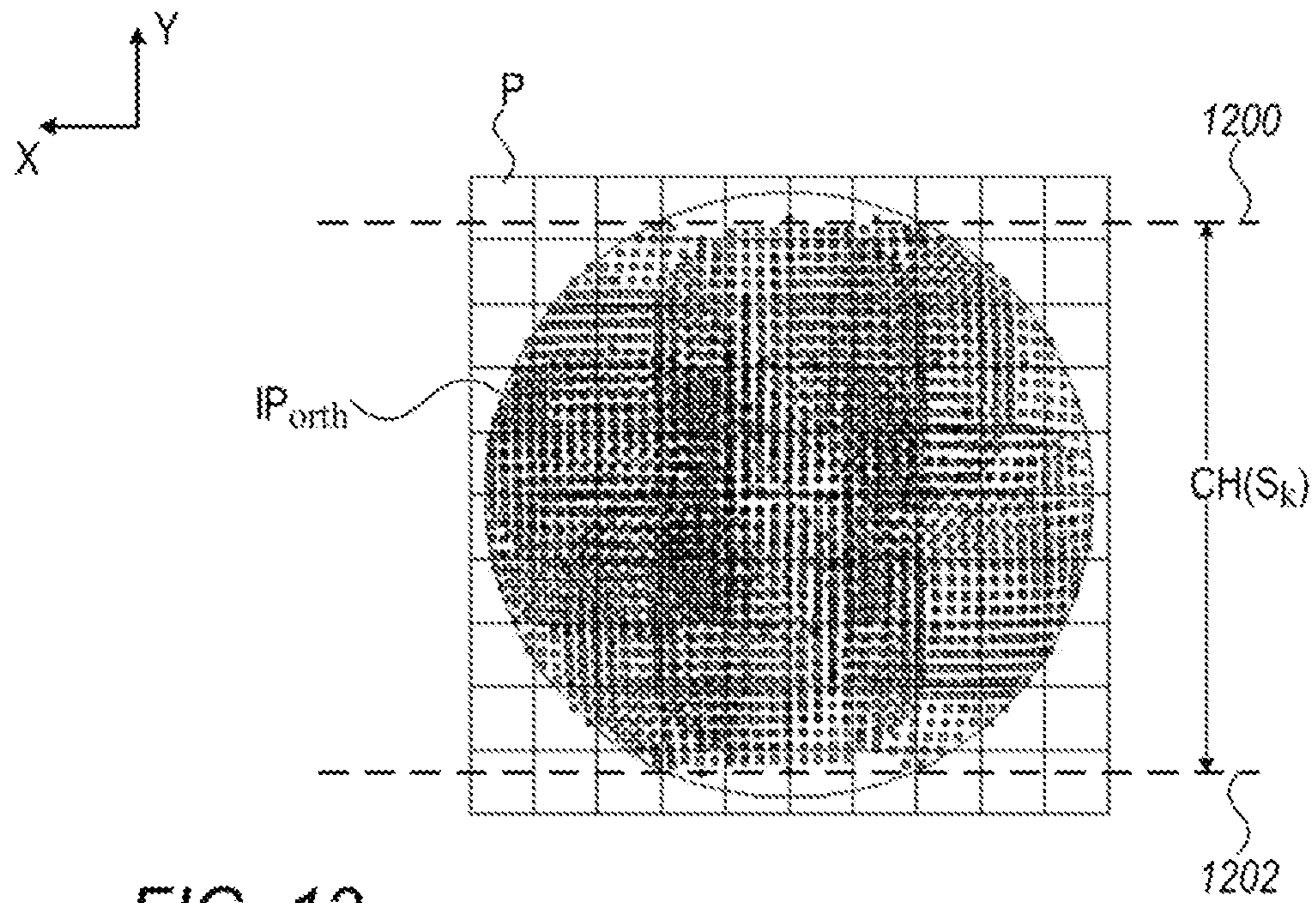

FIG. 12

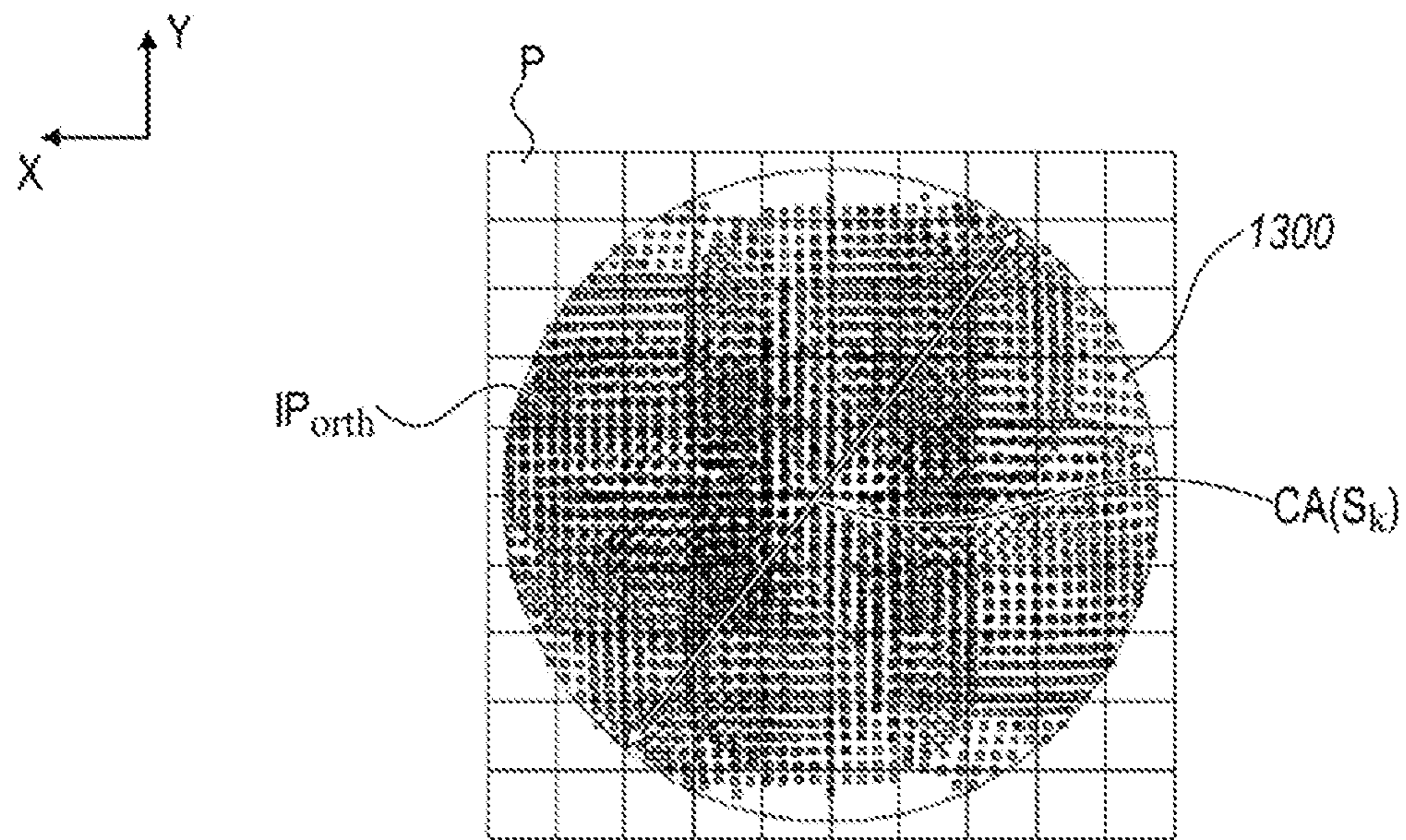

FIG. 13

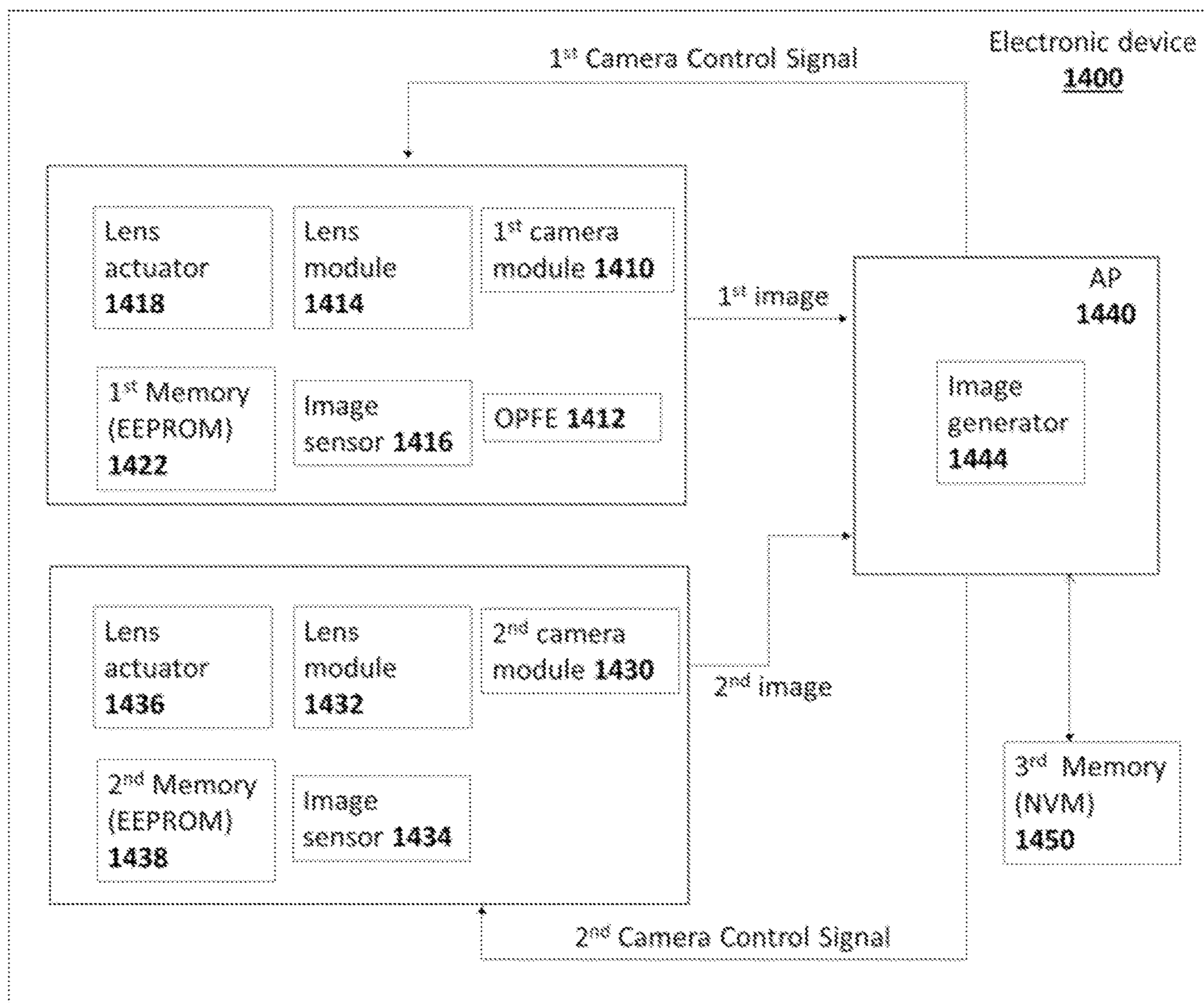

FIG. 14

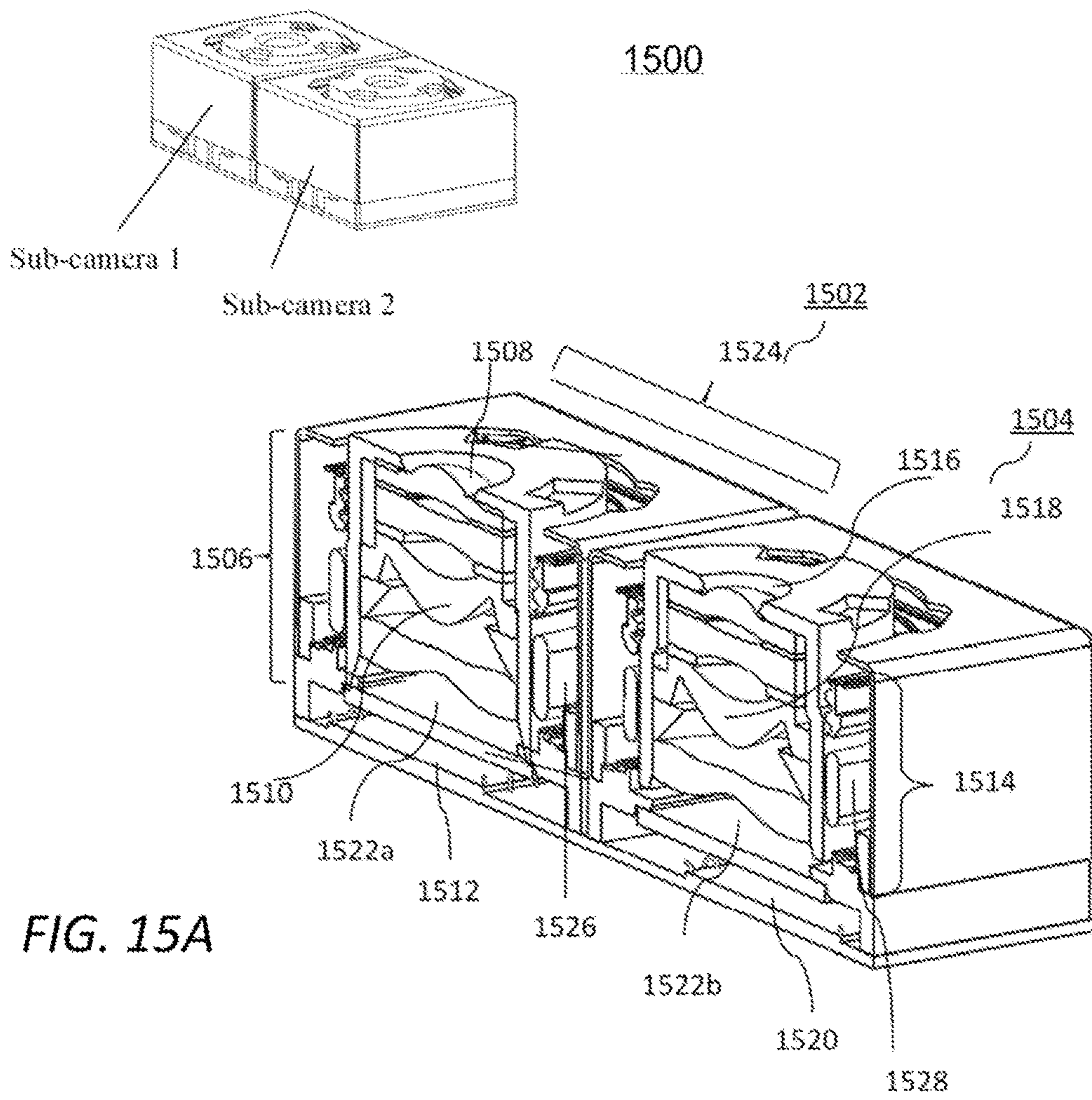

FIG. 15A

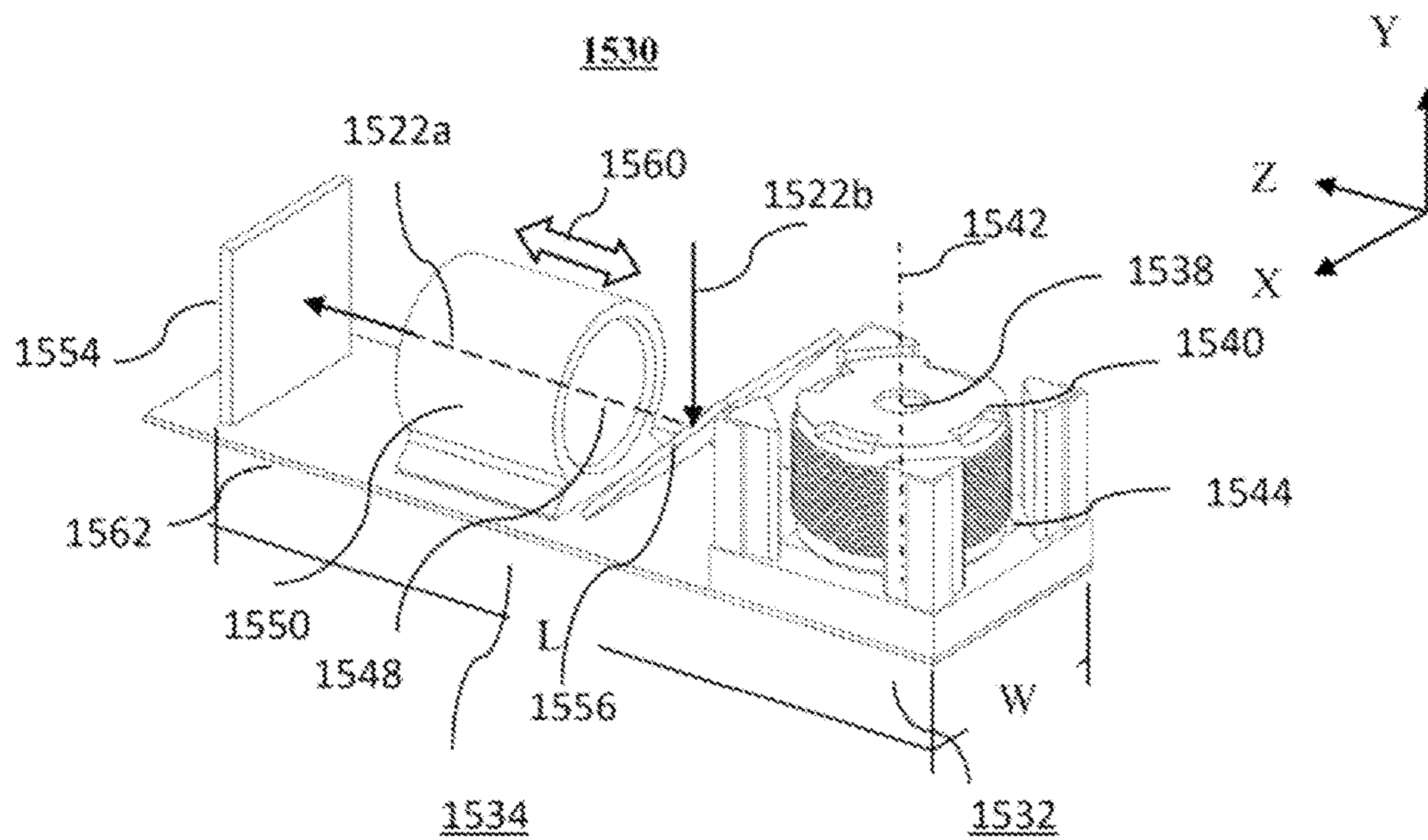

FIG. 15B

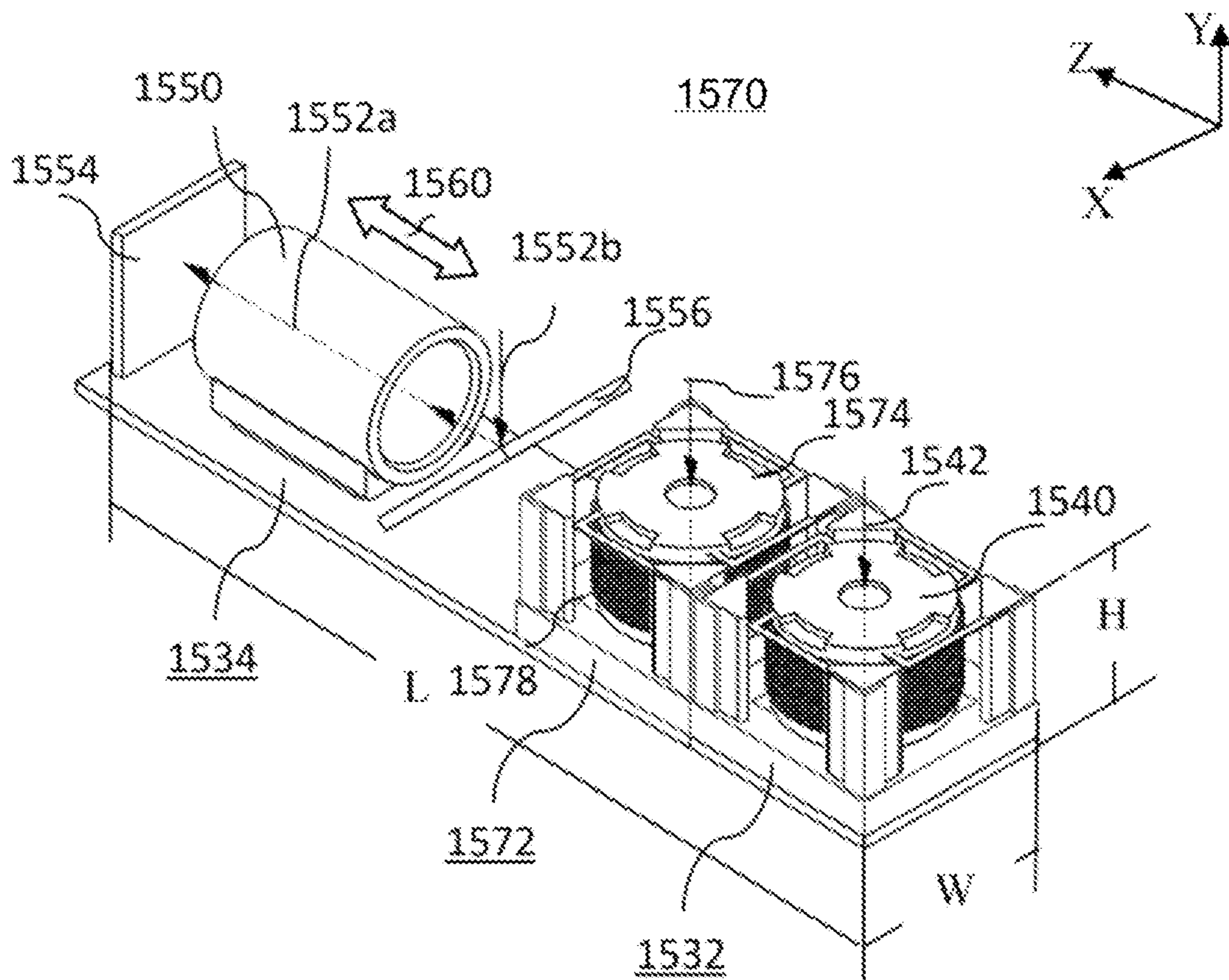

FIG. 15C

MULTI-APERTURE CAMERAS WITH AT LEAST ONE TWO STATE ZOOM CAMERA

CROSS REFERENCE TO RELATED APPLICATIONS

This is a continuation of U.S. patent application Ser. No. 16/975,721 filed Aug. 26, 2020 (now allowed), which was a 371 application from international patent application PCT/IB2020/050002 filed on Jan. 1, 2020, which claims priority from U.S. Provisional Patent Applications No. 62/787,826 filed on Jan. 3, 2019 and No. 62/809,871 filed on Feb. 25, 2019, both of which are expressly incorporated herein by reference in their entirety.

FIELD

Embodiments disclosed herein relate in general to digital cameras, and more particularly, to dual-aperture zoom digital cameras with a folded zoom lens.

BACKGROUND

Compact multi-aperture and in particular dual-aperture (also referred to as “dual-lens” or “dual-camera”) digital cameras are known. Miniaturization technologies allow incorporation of such cameras in compact portable electronic devices such as tablets and mobile phones (the latter referred to hereinafter generically as “smartphones”), where they provide advanced imaging capabilities such as zoom, see e.g. co-owned PCT patent applications No. PCT/IB2015/056004, which is incorporated herein by reference in its entirety. Such cameras and/or cameras disclosed herein are cameras with strict height limitation, normally of less than 1cm, the thinner the better.

Dual-aperture zoom cameras in which one camera has a wide field of view FOV_w (referred to as “Wide camera”) and the other has a narrower, “telephoto” FOV_T (referred to as “Tele camera”) are known. A Tele camera is required to have dimensions as small as possible in order to fit the thickness of the device in which the camera is installed (preferably without protruding from the device’s casing), while being suitable to operate with commonly used image sensors. This problem is even more crucial when using a Tele lens with a long (Tele) effective focal length (EFL) to obtain a relatively high zooming effect. As known, the term “EFL” as applied to a lens refers to the distance from a rear principal plane to a paraxial focal plane. The rear principal plane is calculated by tracing an on-axis paraxial ray from infinity and determined using the paraxial’s image space marginal ray angle.

Dual-aperture zoom cameras comprising an upright Wide camera and a folded Tele camera are also known, see. e.g. co-owned U.S. Pat. No. 9,392,188. The Wide camera is an “upright” camera comprising a Wide image sensor (or simply “sensor”) and a Wide lens module that includes a Wide fixed focus lens assembly (or simply “lens”) with a Wide lens symmetry axis. The folded Tele camera comprises a Tele image sensor and a Tele lens module that includes a Tele fixed focus lens with a Tele lens symmetry axis. The dual-aperture zoom camera further comprises a reflecting element (also referred to as optical path folding element or “OPFE”) that folds light arriving from an object or scene along a first optical path to a second optical path toward the Tele image sensor. The first and second optical paths are perpendicular to each other. The Wide lens symmetry axis is along (parallel to) the first optical path and the Tele lens symmetry axis is along the second optical path. The reflect-

ing element has a reflecting element symmetry axis inclined substantially at 45 degrees to both the Wide lens symmetry axis and the Tele lens symmetry axis and is operative to provide a folded optical path between the object and the Tele image sensor.

The Wide lens has a Wide field of view (FOV_w) and the Tele lens has a Tele field of view (FOV_T) narrower than FOV_w . In an example, the Tele camera provides a $\times 5$ zooming effect, compared to the Wide camera.

Compact folded cameras with lens assemblies that include a plurality of lens elements divided into two or more groups, with one or more (“group”) of lens elements movable relative to another lens element or group of lens elements, are also known. Actuators (motors) used for the relative motion include step motors with screws or piezoelectric actuators. However, a general problem with such cameras is that their structure dictates a rather large F number (F #) of 3 and more, with F # increasing with the zoom factor. Their actuators are slow and noisy (piezoelectric) or bulky (stepper motors), have reliability problems and are expensive. Known optical designs also require a large lens assembly height for a given F # for the two extreme zoom states obtained in such cameras.

SUMMARY

In exemplary embodiments, there are provided dual-cameras comprising: a Wide camera comprising a Wide lens and a Wide image sensor, the Wide lens having a Wide effective focal length EFL_w ; and a folded Tele camera comprising a Tele lens with a first optical axis, a Tele image sensor (or simply “Tele sensor”) and an OPFE, wherein the Tele lens includes, from an object side to an image side, a first lens element group G1, a second lens element group G2 and a third lens element group G3, wherein at least two of the lens element groups are movable relative to the Tele sensor along the first optical axis to bring the Tele lens to two zoom states, wherein an effective focal length of the Tele lens is changed from a value $EFL_{T,min}$ in one zoom state to a value $EFL_{T,max}$ in the other zoom state, wherein $EFL_{T,min} > 1.5 \times EFL_w$ and wherein $EFL_{T,max} > 1.5 \times EFL_{T,min}$.

The Wide lens has a second optical axis, the second optical axis being perpendicular to the first optical axis.

In some exemplary embodiments, the Tele camera is configured to focus by shifting G1, G2 and G3 relative to each other, in both the first and the second zoom states.

In some exemplary embodiments, G1, G2 and G3 are arranged from the object side to the image side, wherein G1 has a positive refractive power, G2 has a positive refractive power and G3 has a negative refractive power.

In some exemplary embodiments, the at least two movable lens element groups include G1 and G3, wherein G1 and G3 are movable relative to the Tele sensor and to G2 and wherein G2 is stationary relative to the Tele sensor. In some embodiments, G3 may further be movable for focus relative to the Tele sensor, G1 and G2. In some embodiments, G1 may further be movable for focus relative to the Tele sensor, G2 and G3.

In an exemplary embodiment, a first lens element L1 toward the object side has a clear aperture (CA) value (or simply “clear aperture”) larger than clear apertures of all other lens elements in the Tele lens.

In an exemplary embodiment, the Tele lens has a total track length (TTL_T) and a maximum TTL ($TTL_{T,max}$) fulfills the condition $TTL_{T,max} < EFL_{T,max}$.

In an exemplary embodiment, the Tele lens has a total track length (TTL_T) and a maximum TTL (TTL_{Tmax}) fulfills the condition $TTL_{Tmax} < 0.9 \times EFL_{Tmax}$.

In an exemplary embodiment, the Tele lens has a Tele lens f-number ($F \#_T$) and a minimal value of $F \#_T$ ($F \#_{Tmin}$) fulfills the condition $F \#_{Tmin} < 1.5 \times F \#_{Tmax} \times EFL_{Tmin} / EFL_{Tmax}$.

In an exemplary embodiment, the Tele lens has a Tele lens f-number ($F \#_T$) and a minimal value of $F \#_T$ ($F \#_{Tmin}$) and a maximal value of $F \#_T$ ($F \#_{Tmax}$) fulfill the condition $F \#_{Tmin} < 1.8 \times F \#_{Tmax} \times EFL_{Tmin} / EFL_{Tmax}$.

In an exemplary embodiment, the Tele lens has a Tele lens f-number ($F \#_T$) and a minimal value of $F \#_T$ ($F \#_{Tmin}$) and a maximal value of $F \#_T$ ($F \#_{Tmax}$) fulfill the condition $F \#_{Tmin} < 1.2 \times F \#_{Tmax} \times EFL_{Tmin} / EFL_{Tmax}$.

In an exemplary embodiment, for any lens element group, the movement from the first zoom state to the second zoom state has a stroke smaller than $0.75 \times (EFL_{Tmax} - EFL_{Tmin})$.

In an exemplary embodiment, for any lens element group, the movement from the first zoom state to the second zoom state has a stroke smaller than $0.6 \times (EFL_{Tmax} - EFL_{Tmin})$.

In an exemplary embodiment, first lens element L1 is a cut lens element.

In some exemplary embodiments, the at least two movable lens element groups include lens element groups G1, G2 and G3, wherein G1 and G3 are movable as one unit relative to the Tele sensor and to G2 in a given range $R_{1,3}$ and wherein G2 is movable relative to the Tele sensor in a range R_2 smaller than $R_{1,3}$. In an exemplary embodiment, G1, G2 and G3 are movable toward the image side. In some exemplary embodiments, G1, G2 and G3 are movable for focusing relative to the Tele sensor as one unit.

In some exemplary embodiments, $EFL_{Tmin} = 15$ mm and $EFL_{Tmax} = 30$ mm.

In some exemplary embodiments, $EFL_{Tmin} = 13$ mm and $EFL_{Tmax} = 26$ mm.

In some exemplary embodiments, at the two zoom states, wherein R_{AF} is a maximal range of movement of G2 required for focus between infinity and 1 meter, $R_{AF} < 0.4 \times R_2$. In some exemplary embodiments, at the two zoom states, wherein RA is a maximal range of movement of G1 and G3 required for focus between infinity and 2 meter, $R_{AF} < 0.4 \times R_{1,3}$.

In some exemplary embodiments, actuation for the movement of G2 is performed in close loop control.

In some exemplary embodiments, actuation for the movement of G1 and G3 is performed in open loop control.

In some exemplary embodiments, the movement of G1, G2 and G3 is created using voice coil motor (VCM) mechanisms.

In some exemplary embodiments, the movement of G1, G2 and G3 is guided along the first optical axis by a ball guided mechanism that creates a linear rail. In some exemplary embodiments, the ball guided mechanism includes at least one groove on a G2 lens carrier, at least one groove on a G1+G3 lens carrier, and a plurality of balls between the grooves on the G2 lens carrier and the G1+G3 lens carrier.

In an exemplary embodiment, there is provided a dual-camera comprising: a Wide camera comprising a Wide lens and a Wide image sensor, the Wide lens having a Wide effective focal length EFL_W ; and a folded Tele camera comprising a Tele lens with a first optical axis, a Tele sensor and an OPFE, wherein the Tele lens includes, from an object side to an image side, a first lens element group G1, a second lens element group G2 and a third lens element group G3, wherein G1 and G3 are movable along the first optical axis as one unit relative to the Tele sensor and G2 in a given range $R_{1,3}$, wherein G2 is movable along the first optical axis

relative to the Tele sensor in a range R_2 smaller than $R_{1,3}$, wherein the combined movements of G1, G2 and G3 bring the Tele lens to two zoom states, wherein an EFL of the Tele lens is changed from $EFL_{T,min}$ in one zoom state to $EFL_{T,max}$ in the other zoom state and wherein $EFL_{Tmin} > EFL_W$ and wherein $EFL_{Tmax} > 1.5 \times EFL_{Tmin}$.

In an exemplary embodiment, there is provided a folded camera comprising: a lens with a first optical axis, an image sensor and an OPFE, wherein the lens includes, from an object side to an image side, a first lens element group G1, a second lens element group G2 and a third lens element group G3, wherein G1 and G3 are movable along the first optical axis as one unit relative to the image sensor and G2 in a given range $R_{1,3}$, wherein G2 is movable along the first optical axis relative to the image sensor in a range R_2 smaller than $R_{1,3}$, wherein the combined movements of G1, G2 and G3 bring the lens to two zoom states, wherein an EFL of the lens is changed from a value $EFL_{,min}$ in one zoom state to a value EFL_{Tmax} in the other zoom state and wherein $EFL_{max} > 1.5 \times EFL_{min}$,

In an exemplary embodiment, there is provided a triple-camera, comprising: a Wide camera comprising a Wide lens and a Wide image sensor, the Wide lens having a Wide effective focal length EFL_W , an Ultra-Wide camera comprising an Ultra-Wide lens and an Ultra-Wide image sensor, the Ultra-Wide lens having an Ultra-Wide effective focal length EFL_{UW} , and a folded Tele camera comprising a Tele lens with a first optical axis, a Tele sensor and an OPFE, wherein the Tele lens includes, from an object side to an image side, a first lens element group G1, a second lens element group G2 and a third lens element group G3, wherein at least two of the lens element groups are movable relative to the Tele sensor along the first optical axis to bring the Tele lens to two, first and second zoom states, wherein an EFL of the Tele lens is changed from a value $EFL_{T,min}$ in the first zoom state to a value $EFL_{T,max}$ in the second zoom state, wherein $EFL_{Tmin} > 2 \times EFL_{UW}$, wherein $EFL_{Tmin} > 1.5 \times EFL_W$ and wherein $EFL_{Tmax} > 1.5 \times EFL_{Tmin}$,

In an exemplary embodiment, there is provided a dual-camera module comprising: a Wide camera module, and a Tele camera module comprising a lens module, a lens actuator for moving the lens module between a first and a second zoom state, and a memory for storing first and a second calibration data, wherein the first calibration data may comprise calibration data between the Wide camera module and the Tele camera module in a first zoom state, and wherein the second calibration data may comprise calibration data between the Wide camera module and the Tele camera module in a second zoom state.

In various exemplary embodiments, there is provided a system comprising: an application processor (AP), a Wide camera module for providing first image data, a Tele camera module for providing second image data, the Tele camera module comprising a lens module, and a lens actuator for moving a lens module between a first and a second zoom state, and a memory for storing a first and a second calibration data, wherein the first calibration data may comprise calibration data between the Wide camera module and the Tele camera module in the first zoom state and second calibration data between the Wide camera module and the Tele camera module in the second zoom state, and wherein the AP is configured to generate third image data by processing the first and second image data and by using the first calibration data when the Tele camera module is in the first zoom state and the second calibration data when the Tele camera module is in the second zoom state.

5

In an embodiment of the system, the first calibration data is stored in the first camera module, and the second calibration data is stored in the second camera module.

In an embodiment of the system, the first calibration data and the second calibration data are stored only in the Tele camera module.

In an embodiment of the system, the first calibration data and the second calibration data are stored only in the Wide camera module.

In an embodiment of the system, the first calibration data and the second calibration data are stored in a memory not located in the Wide camera module or in the Tele camera module.

In an embodiment of the system, a first portion of the first calibration data and a first portion of the second calibration data are stored in a memory located in the Wide camera module or in the Tele camera module, and a second portion of the first calibration data and a second portion of the second calibration data are stored in a memory not located in the Wide camera module or in the Tele camera module.

BRIEF DESCRIPTION OF THE DRAWINGS

Non-limiting examples of embodiments disclosed herein are described below with reference to figures attached hereto that are listed following this paragraph. Identical structures, elements or parts that appear in more than one figure are generally labeled with a same numeral in all the figures in which they appear. If identical elements are shown but numbered in only one figure, it is assumed that they have the same number in all figures in which they appear. The drawings and descriptions are meant to illuminate and clarify embodiments disclosed herein and should not be considered limiting in any way. In the drawings:

FIG. 1A shows schematically a general perspective view of a dual-camera, comprising an upright camera and a zoom folded camera;

FIG. 1B shows the dual-camera of FIG. 1A in an exploded view;

FIG. 2A shows a zoom folded camera as in FIGS. 1A and 1B with a first lens optical design in a first zoom state and with ray tracing;

FIG. 2B shows a zoom folded camera as in FIGS. 1A and 1B with the first lens optical design in a second zoom state and with ray tracing;

FIG. 2C shows details of the lens elements of the first optical design in the first zoom state;

FIG. 2D shows details of the lens elements of the first optical design in the second zoom state;

FIG. 3A shows details of the lens elements of a second optical design in a first zoom state;

FIG. 3B shows details of the lens elements of the second optical design in a second zoom state;

FIG. 4A shows details of the lens elements of a third optical design in a first zoom state;

FIG. 4B shows details of the lens elements of the third optical design in a second zoom state;

FIG. 4C shows details of the lens elements of a fourth optical design in a first zoom state;

FIG. 4D shows details of the lens elements of the fourth optical design in a second zoom state;

FIG. 4E shows details of the lens elements of a fifth optical design in a first zoom state;

FIG. 4F shows details of the lens elements of the fifth optical design in a second zoom state;

FIG. 4G shows details of the lens elements of a sixth optical design in a first zoom state;

6

FIG. 4H shows details of the lens elements of the sixth optical design in a second zoom state;

FIG. 5A shows schematically a Tele lens and sensor module with a lens having the optical design of the second example in a EFL_{Tmin} state from a top perspective view;

FIG. 5B shows schematically the Tele lens and sensor module of FIG. 5A from another top perspective view;

FIG. 5C shows schematically the Tele lens and sensor module with a lens having the optical design of the second example in a EFL_{Tmax} state from one top perspective view;

FIG. 5D shows schematically the Tele lens and sensor module of FIG. 5C from another top perspective view;

FIG. 5E shows an exploded view of the Tele lens and sensor module of FIGS. 5A-5D;

FIG. 6A shows a bottom view of the top and bottom actuated sub-assemblies of Tele lens and sensor module in the EFL_{Tmin} state like in FIGS. 5A and 5B from one perspective;

FIG. 6B shows a bottom view of the top and bottom actuated sub-assemblies of Tele lens and sensor module in the EFL_{Tmax} state like in FIGS. 5C and 5D from another perspective;

FIG. 6C shows the top actuated sub-assembly from a bottom view;

FIG. 7 shows details of stationary rails in the Tele lens and sensor module of FIG. 5;

FIG. 8 shows an electronic sub-assembly in the Tele lens and sensor module of FIG. 5;

FIG. 9A shows a lens element having axial symmetry;

FIG. 9B shows a cut lens element with two cuts;

FIG. 10 illustrates in a flow chart an exemplary method for operating a zoom folded camera disclosed herein;

FIG. 11A is a schematic view of impact points of optical rays impinging a convex surface of a lens element, and a schematic view of the orthogonal projection of the impact points on a plane P, according to some examples of the presently disclosed subject matter;

FIG. 11B is a schematic view of impact points of optical rays impinging a concave surface of a lens element, and a schematic view of the orthogonal projection of the impact points on a plane P, according to some examples of the presently disclosed subject matter;

FIG. 12 is a schematic representation of the orthogonal projection of the impact points on a plane P, and of a clear height value ("CH"), according to some examples of the presently disclosed subject matter;

FIG. 13 is a schematic representation of the orthogonal projection of the impact points on a plane P, and of a clear aperture, according to some examples of the presently disclosed subject matter.

FIG. 14 shows schematically in a block diagram an embodiment of a system disclosed herein;

FIGS. 15A, 15B and 15C show schematically designs of dual-aperture cameras and triple-aperture cameras comprising folded and non-folded lens designs.

DETAILED DESCRIPTION

FIG. 1A shows schematically a general perspective view of an embodiment of a dual-camera numbered **100**, comprising an upright Wide camera **102**, and a folded Tele camera **103** comprising an OPFE **104** (e.g. a prism), and a zoom folded Tele camera lens and sensor module (or simply "module") **106**. Wide camera includes a Wide lens **110** with a fixed effective focal length EFL_w . For example, EFL_w may be 2-5 mm. In Tele camera **103**, OPFE **104** is held in a prism holder **108**. Module **106** includes a shield **107**. Shield **107**

may cover some or all elements of module **106** or camera **103**. FIG. 1B shows dual-camera **100** with shield **107** removed and with more details. Module **106** further includes a Tele lens **114** with a Tele lens optical axis **116**, a Tele sensor **118**, and, optionally, a glass window **130** (see e.g. FIG. 2A). Glass window **130** may be used for filtering light at infra-red (IR) wavelengths, for mechanical protection of sensor **118** and/or for protection of sensor **118** from dust. For simplicity, the word “Tele” used with reference to the camera, lens or image sensor may be dropped henceforth. In some embodiments, the lens and image sensor modules are separated, such that the Tele sensor has its own module, while other functionalities and parts described below (in particular lens actuator structure **502** of FIGS. 5A-E) remain in a Tele camera lens module only. The entire description below refers to such embodiments as well. In other embodiments, a system described herein may comprise one or more additional cameras, forming e.g. a triple-camera system. Besides a Wide and a Tele camera, a triple-camera may include also an Ultra-Wide camera, wherein an Ultra-Wide camera EFL, $EFL_{UW} < 0.7 \times EFL_W$.

Dual-camera **100** further comprises, or is coupled to, a controller (not shown) that controls various camera functions, including the movement of lens groups and elements described below.

Lens **114** includes three groups of lens elements G1, G2 and G3, housed respectively in a first group (G1) lens housing (or “holder”) **120**, a second group (G2) lens housing **122** and a third group (G3) lens housing **124**. Details of three different lens designs for lens element groups G1, G2 and G3 are provided below with reference to FIGS. 2-4. In various embodiments described in detail next, at least one lens element group moves relative to another lens element group along lens optical axis **116** to provide at least two Tele lens effective focal lengths EFL_T : a minimum EFL_{Tmin} and a maximum EFL_{Tmax} . For example, EFL_{Tmin} may be 10-20 mm and EFL_{Tmax} may be 20-40 mm. This provides zoom capability between two large EFLs while keeping a small Tele lens f-number ($F\#_T$). In addition, EFL_{Tmin} is larger than the EFL_W , for example by 2 times or more, such that optical zoom may be provided by dual-camera **100** between EFL_W and EFL_{Tmax} . In addition for EFL, for each zoom state a Tele lens total track length (TTL_T) is defined as the distance along the optical axis from the first surface of the first lens element toward the object side (S_1 , see below) to the image sensor surface, when the lens is focused at infinity, and including all lens elements and the glass window. TTL_{Tmin} is defined for the first zoom state and TTL_{Tmax} is defined for the second zoom state. TTL_{Tmin} and TTL_{Tmax} are marked for example in FIGS. 2C, 2D, 3A and 3B, but the definitions apply for all embodiments in this application.

FIG. 2A shows a zoom folded Tele camera **103'** like camera **103** with OPFE **104** (e.g. prism), a lens **114'** like lens **114**, and image sensor **118** with a first exemplary optical design of a Tele lens **114'** and with ray tracing, where the Tele lens is in a first zoom state, i.e. with $EFL = EFL_{Tmin}$. In addition, a glass window **130** may be positioned between all lens elements and image sensor **118**. FIG. 2B shows folded Tele camera **103'** in a second zoom state, i.e. with $EFL = EFL_{Tmax}$. FIG. 2C shows details of a lens **114'** of the first optical design in the first zoom state, and FIG. 2D shows details of lens **114'** in the second zoom state.

Lens **114'** has a first exemplary optical design, represented by Tables 1-4 and includes eight lens elements marked L1-L8, starting with L1 on an object side facing the prism (“object side”) and ending with L8 on an image side toward the image sensor. Table 1 provides optical data for each of

the surfaces in the optical lens design. The optical data of the OPFE (prism or mirror) is omitted from Table 1, as many OPFE designs known in the art can be used between the object and S_1 . Non-limiting examples of such OPFEs include: a prism made of glass or plastic, such that the refractive index of the prism may change (e.g. in a range of 1-3); an OPFE that limits stray light (e.g. as disclosed in co-owned international patent application PCT/IB2018/054928); a low profile prism (see e.g. co-owned U.S. provisional patent application 62/657,003); a scanning OPFE (see e.g. co-owned international patent applications PCT/IB2018/050885 and PCT/IB2017/); an OPFE with OIS mechanism (see e.g. co-owned U.S. Pat. No. 9,927,600); and a mirror.

Table 2 provides zoom data, which is additional data for distances between surfaces in Table 1, as well as changing parameters for various zoom positions. Table 3 provides aspheric data, which is additional optical data for surfaces in Table 1 that are not spherical. Table 4 provides lens elements and lens elements groups focal lengths in mm. Similar Tables exist for a second exemplary optical design (Tables 5-8), a third exemplary optical design (Tables 9-12) a fourth exemplary optical design (Tables 13-16) and a fifth exemplary optical design (Tables 17-20) below.

Lenses disclosed in various exemplary embodiments below comprise several lens groups (G1, G2, G3, etc.) of lens elements, each group including a plurality of lens elements marked Li. Each lens element Li has a respective front surface S_{2i-1} and a respective rear surface S_{2i} where “i” is an integer between 1 and N. As used herein, the term “front surface” of each lens element refers to the surface of a lens element located closer to the entrance of the camera (camera object side) and the term “rear surface” refers to the surface of a lens element located closer to the image sensor (camera image side). The front surface and/or the rear surface can be in some cases aspherical. The front surface and/or the rear surface can be in some cases spherical. These options are, however, not limiting. Lens elements L1 to LN may be made from various materials, for example plastic or glass. Some lens elements may be made of different materials than other lens elements. The notations “Gi”, “Li”, “Si” are shown in several figures as an example (see FIGS. 2C, 2D for “Gi” notations, FIG. 2B for “Li” notations and FIG. 4A for “Si” notations), however these notations apply for all embodiments in this application.

In this specification, “height” of a part, an element, or of a group of parts or elements is defined as a distance in the direction of the first optical axis (Y direction in an exemplary coordinate system) between the lowermost point of the part/element/group and the upper-most point of the part/element/group. The term “upper” or “top” refers to a section of any part/element/group that is closer to and facing an imaged (photographed) object along Y relative to other sections of the same part/element or group. The term “lower” or “bottom” refers to a section of any part/element/group that is farthest from and facing away from an imaged object along Y relative to other sections of the same part/element or group.

In Table 1 (as well as in Tables 5 and 9), R is the radius of curvature of a surface and T is the distance from the surface to the next surface parallel to an optical axis. Since the distance between some lens elements change with zooming and focusing, additional thickness data is given in Tables 2, 6 and 10 for various zoom and focus positions. Note that the TTL_T is the sum of all T values starting from S_1 and to the image sensor, when additional data from Tables 2, 6 and 10 is used with the object set at infinity. D is the optical

diameter of the surface. $D/2$ expresses a “semi-diameter” or half of the diameter. The units of R , T , and D are millimeters (mm). N_d and V_d are the refractive index and Abbe number of the lens element material residing between the surface and the next surface, respectively.

Surface types are defined in Tables 1, 5 and 9 and the coefficients for the surfaces are in Tables 3, 7 and 11:

flat surfaces—has infinity radius of curvature;

Even-Aspherical (EVAS) surfaces, which are defined using Eq. 1 and their details given in Tables 3, 7 and 11:

$$EVAS = \frac{cr^2}{1 + \sqrt{1 - (1+k)c^2r^2}} + \alpha_2r^4 + \alpha_3r^6 \quad (\text{Eq. 1})$$

where r is the distance of a point in the optical surface from (and perpendicular to) the relevant optical axis (first or second), k is the conic coefficient, $c=1/R$, and α are coefficients given in Tables 3, 7 and 11. Note that, for any aspheric surface, the maximum value of r (“max r ”) is the semi-diameter ($D/2$) of the respective surface.

QT1 surfaces are defined using Eq. 2 and sub-equations below:

$$QT1 = \frac{cr^2}{1 + \sqrt{1 - (1+k)c^2r^2}} + D_{con}(u) \quad (\text{Eq. 2})$$

$$D_{con}(u) = u^4 \sum_{n=0}^5 A_n Q_n^{con}(u^2)$$

$$u = \frac{r}{NR} \quad x = u^2$$

-continued

$$Q_0^{con}(x) = 1 \quad Q_1^{con} = -(5 - 6x) \quad Q_2^{con} = 15 - 14x(3 - 2x)$$

$$Q_3^{con} = -\{35 - 12x[14 - x(21 - 10x)]\}$$

$$Q_4^{con} = 70 - 3x\{168 - 5x[84 - 11x(8 - 3x)]\}$$

$$Q_5^{con} = -[126 - x\{1260 - 11x\{420 - x[720 - 13x(45 - 14x)]\}]$$

where $\{z, r\}$ are the standard cylindrical polar coordinates, c is the paraxial curvature of the surface, k is the conic parameter, NR is the norm radius, and A_1 are the polynomial coefficients shown in lens data tables.

A “stop surface” (Tables 2, 6, 10, 14, 18 and 22): in the embodiments disclosed, the position of a lens aperture stop surface may change when shifting from a first zoom state to a second zoom state. In this case, the stop determines the $F \#$ of the entire lens module. For example in some embodiments the amount of light reaching the image plane to form an image for center field in a first zoom state is determined by an aperture stop near the first lens from object side L1, whereas in a second zoom state the amount of light reaching the image plane to form an image for center field is determined by an aperture stop near another lens element, for example near lens element L4. In other embodiments, the position of a lens aperture stop surface may not change when shifting from a first zoom state to a second zoom state. The reflective surface of the prism, also commonly known as a “mirror”.

The diameter D of the image sensor as presented in the tables below refers to a possible size of the image sensor diagonal.

TABLE 1

Group	Lens	Surface	Type	R [mm]	T [mm]	N_d	V_d	D [mm]
Object		S_0	Flat	Infinity	See Table 2			
G1	L1	S_1	EVAS	5.997	1.224	1.4847	84.150	7.50
G1	L1	S_2	EVAS	13.606	2.104			7.50
G1	L2	S_3	EVAS	-19.106	0.509	1.8446	23.750	6.73
G1	L2	S_4	EVAS	-25.364	See Table 2			6.24
G2	L3	S_5	EVAS	11.959	0.864	1.5348	55.660	4.76
G2	L3	S_6	EVAS	-9.715	0.422			4.76
G2	L4	S_7	EVAS	-3.692	0.656	1.6510	21.510	4.40
G2	L4	S_8	EVAS	-4.784	See Table 2			4.27
G3	L5	S_9	EVAS	-8.017	0.719	1.6510	21.510	4.00
G3	L5	S_{10}	EVAS	-1293.029	0.635			3.55
G3	L6	S_{11}	EVAS	-670.457	0.598	1.6510	21.510	3.59
G3	L6	S_{12}	EVAS	-7.424	0.073			3.88
G3	L7	S_{13}	EVAS	-7.140	0.624	1.6510	21.510	3.93
G3	L7	S_{14}	EVAS	-4.715	0.068			4.16
G3	L8	S_{15}	EVAS	-3.913	0.798	1.5348	55.660	4.22
G3	L8	S_{16}	EVAS	45.594	See Table 2			4.35
Glass		S_{17}	Flat	Infinite	0.210	1.5168	64.170	
window		S_{18}	Flat	Infinite	0.500			
Image sensor		S_{19}	Flat	Infinite	0			

TABLE 2

Object position Stop surface		First zoom state EFL _T = 15 mm		Second zoom state EFL _T = 30 mm	
		at infinity	at 1 meter	at infinity	at 1 meter
		S8		S1	
T [mm]	S ₀	Infinity	1000	Infinity	1000
	S ₄	0.131	0.131	11.403	11.403
	S ₈	5.080	5.364	0.060	0.434
	S ₁₆	1.094	0.810	6.114	5.740

TABLE 3

Surface	Conic (k)	α_2	α_3
S1	0.512	-2.110E-04	-3.814E-06
S2	0.273	3.572E-04	1.917E-05
S3	20.233	5.134E-03	-4.188E-05
S4	37.580	5.156E-03	-2.918E-06
S5	-17.980	3.967E-04	-2.603E-04
S6	4.558	9.386E-04	-2.360E-04
S7	-0.178	7.713E-03	-3.679E-04
S8	0.700	5.789E-03	-1.981E-04
S9	-37.208	2.833E-02	-2.126E-03
S10	-2.729	3.813E-02	1.651E-03
S11	-9.193	-2.622E-02	4.029E-03
S12	-5.072	-1.207E-02	3.646E-03
S13	9.708	1.232E-02	-6.426E-04
S14	3.593	2.145E-03	4.976E-04
S15	1.298	1.152E-02	2.260E-03
S16	-8.975	-1.222E-03	-1.182E-04

TABLE 4

Lens #	Lens or group focal length [mm]
L1	14.88
L2	-28.15
L3	12.85
L4	-49.00
L5	65.32
L6	-9.17
L7	-32.37
L8	19.45
G1	23.01
G2	15.28
G3	-11.55

In a first example ("Example 1"), lens elements L1-L8 are grouped into three groups: a first group G1 comprising lens elements L1 and L2, a second group G2 comprising lens elements L3 and L4 and a third group comprising lens elements L5-L8. Note that the lens or group focal lengths listed in Table 4 have positive or negative values, which indicate respective positive or negative refractive powers of the associates lens elements or groups. Thus, in Table 4, L1, L3, L5 and L8 have positive refractive powers and L2, L4, L6 and L7 have negative refractive powers. Similarly, G1 and G2 have positive refractive powers and G3 has negative refractive power. This applies also to Tables 8 and 12.

In Example 1, the camera is brought into two zoom states by moving groups G1 and G3 relative to image sensor **118** while keeping group G2 stationary relative to image sensor **118**. G3 is then further movable for focusing in each of the zoom states. Table 2 specifies the exact distances and relative positioning. In Example 1, G1 and G3 are moved relatively to G2 (and the image sensor) to bring the camera into a first zoom state shown in FIGS. **2A** and **2C** in which EFL_T=EFL_{Tmin}=15 mm, F #=F #_{Tmin}=2.8 and

TTL_T=TTL_{Tmin}=16.309 mm, and into a second zoom state shown in FIGS. **2B** and **2D** in which EFL_T=EFL_{Tmax}=30 mm, F #=F #_{Tmax}=4 and TTL_T=TTL_{Tmin}=27.581 mm. The range of movement may be for example 5-10 mm. In the first state, G1 is separated from G2 by a distance d4 (the distance between S₄ and S₅ in Table 2 for a case of 15 mm EFL, i.e. 0.131 mm), G2 is separated from G3 by a distance d8 (the distance between S₈ and S₉ in Table 2 for a case of 15 mm EFL, i.e. 5.080-5.364 mm, depending on the focus distance) and G3 is separated from window **130** by a distance d16 (the distance between S₁₆ and S₁₇ in Table 2 for a case of 15 mm EFL, i.e. 1.094 to 0.810 mm, depending on the focus distance). In the second state, G1 is separated from G2 by a distance d4' (the distance between S₄ and S₅ in Table 2 for a case of 30 mm EFL, i.e. 11.403 mm), G2 is separated from G3 by a distance d8' (the distance between S₈ and S₉ in Table 2 for a case of 30 mm EFL, i.e. 0.060-0.434 mm, depending on the focus distance) and G3 is separated from window **130** by a distance d16' (the distance between S₁₆ and S₁₇ in Table 2 for a case of 30 mm EFL, i.e. 6.114 mm to 5.740 mm depending on the focus distance).

FIG. **3A** shows details of the lens elements of a second embodiment of an exemplary optical design in a folded Tele camera such as camera **103** in a first zoom state, while FIG. **3B** shows details of the lens elements of the second optical design in a second zoom state. The figures show a lens **114**", image sensor **118** and optional window **130**. The second optical design is represented by Tables 5-8 and includes eight lens elements marked L1-L8, starting with L1 on an object side facing the prism and ending with L8 on an image side toward the image sensor. Table 5 provides optical data, Table 6 provides zoom data, Table 7 provides aspheric data and Table 8 provides lens or group focal length in mm.

In a second example ("Example 2"), in lens **114**", lens elements L1-L8 are grouped into three groups: a first group G1 comprising lens elements L1 and L2, a second group G2 comprising lens elements L3-L5, and a third group comprising lens elements L6-L8.

In Example 2, the camera is brought into two zoom states by moving groups G1 and G3 together relative to the image sensor in a given range R_{1,3} while moving group G2 relative to the image sensor in a range R₂ smaller than R_{1,3}. In Example 2, R_{1,3}=7.509 mm, while R₂=1.574 mm. Group G2 is further movable at any zoom state relative to the image sensor in a range R_{AF} for changing the focal distance of camera **106** from infinity down to 1 meter. RA may be up to 550 micrometers (um), depending on zoom state. FIG. **3A** shows Example 2 in the first zoom state in which EFL_T=EFL_{Tmin}=15 mm, F #=F #_{Tmin}=2 and TTL_T=TTL_{Tmin}=17.373 mm, and FIG. **3B** shows Example 2 in the second zoom state in which EFL_T=EFL_{Tmax}=30 mm, F #=F #_{Tmax}=4, and TTL_T=TTL_{Tmax}=24.881 mm.

13

In Example 2, the following conditions are fulfilled:

$R_{1,3}$ and R_2 are smaller than $0.6 \times (EFL_{Tmax} - EFL_{Tmin})$ and of course smaller than $0.75 \times (EFL_{Tmax} - EFL_{Tmin})$. $F \#_{Tmin}$ is smaller than $1.0 \times F \#_{Tmax} \times EFL_{Tmin} / EFL_{Tmax}$, smaller than $1.2 \times F \#_{Tmax} \times EFL_{Tmin} / EFL_{Tmax}$, smaller than $1.5 \times F \#_{Tmax} \times EFL_{Tmin} / EFL_{Tmax}$ and smaller than $1.8 \times F \#_{Tmax} \times EFL_{Tmin} / EFL_{Tmax}$.

In the first state, G1 is separated from G2 by a distance **d4** (the distance between S_4 and S_5 in Table 6 for a case of 15 mm EFL, i.e. 1.246 to 1.012 mm, depending on the focus distance), G2 is separated from G3 by a distance **d10** (the distance between S_{10} and S_{11} in Table 6 for a case of 15 mm

14

EFL, i.e. 6.136-6.370 mm, depending on the focus distance) and G3 is separated from window **130** by a distance **d16** (the distance between S_{16} and S_{17} in Table 6 for a case of 15 mm EFL, i.e. 0.229 mm). In the second state, G1 is separated from G2 by a distance **d4'** (the distance between S_4 and S_5 in Table 6 for a case of 30 mm EFL, i.e. 7.181 to 6.658 mm, depending on the focus distance), G2 is separated from G3 by a distance **d10'** (the distance between S_{10} and S_{11} in Table 6 for a case of 30 mm EFL, i.e. 0.2 to 0.725 mm, depending on the focus distance) and G3 is separated from window **130** by a distance **d16'** (the distance between S_{16} and S_{17} in Table 6 for a case of 30 mm EFL, i.e. 7.738 mm).

TABLE 5

Group	Lens	Surface	Type	R [mm]	T [mm]	Nd	Vd	D [mm]
Object		S_0	Flat	Infinity	See Table 6			
G1	L1	S_1	QT1	6.615	1.666	1.4847	84.150	7.50
G1	L1	S_2	QT1	71.898	3.268			7.30
G1	L2	S_3	QT1	21.616	0.373	1.8446	23.750	5.87
G1	L2	S_4	QT1	10.973	See Table 6			5.62
G2	L3	S_5	QT1	-37.902	0.700	1.5348	55.660	4.86
G2	L3	S_6	QT1	-5.871	0.132			4.95
G2	L4	S_7	QT1	-23.976	0.744	1.6510	21.510	4.93
G2	L4	S_8	QT1	-4.874	0.067			5.20
G2	L5	S_9	QT1	-5.651	0.869	1.5348	55.660	5.38
G2	L5	S_{10}	QT1	-5.128	See Table 6			5.38
G3	L6	S_{11}	QT1	-4.749	0.250	1.5348	55.660	4.77
G3	L6	S_{12}	QT1	-139.803	0.063			4.74
G3	L7	S_{13}	QT1	-444.631	0.318	1.5348	55.660	4.73
G3	L7	S_{14}	QT1	18.077	0.060			4.75
G3	L8	S_{15}	QT1	15.930	0.542	1.6510	21.510	4.78
G3	L8	S_{16}	QT1	-63.413	See Table 6			4.77
Glass		S_{17}	Flat	Infinity	0.210	1.5168	64.170	
window		S_{18}	Flat	Infinity	0.500			
Image sensor		S_{19}	Flat	Infinity	0			

TABLE 6

Object position	First zoom state $EFL_T = 15$ mm		Second zoom state $EFL_T = 30$ mm		
	at infinity	at 1 meter	at infinity	at 1 meter	
Stop surface	S5		S1		
T [mm]	S_0	Infinity	1000	Infinity	1000
	S_4	1.246	1.012	7.181	6.658
	S_{10}	6.136	6.370	0.200	0.725
	S_{16}	0.229	0.229	7.738	7.738

TABLE 7

Surface	Conic	NR	A_0	A_1	A_2	A_3	A_4	A_5
S_1	0	3.7	-1.071E-02	-7.810E-04	7.874E-05	-9.666E-05	3.754E-06	2.463E-06
S_2	0	3.7	3.115E-02	-1.285E-03	1.465E-04	-2.067E-04	4.660E-05	-9.353E-07
S_3	0	3.7	2.719E-01	-4.051E-02	2.860E-03	5.289E-04	7.861E-04	-8.761E-04
S_4	0	3.7	3.639E-01	-3.214E-02	6.330E-03	2.656E-03	9.124E-04	-1.171E-03
S_5	0	3.7	-1.507E+00	-1.910E-01	-6.434E-02	-1.200E-02	5.825E-04	-5.555E-04
S_6	0	3.7	-8.373E-01	-1.648E-01	-4.615E-04	-1.051E-02	2.529E-03	2.881E-03
S_7	0	3.7	5.590E-01	1.990E-02	1.374E-01	8.401E-03	6.293E-03	6.466E-03
S_8	0	3.7	4.388E-01	-1.366E-01	5.125E-02	-1.241E-02	-2.885E-03	8.741E-04
S_9	0	3.7	5.075E-01	-1.496E-02	6.068E-02	1.246E-02	-8.803E-04	-4.615E-03
S_{10}	0	3.7	-8.004E-02	-5.974E-02	-2.987E-02	-2.815E-03	7.390E-04	-1.480E-03
S_{11}	0	3.7	8.519E-01	-5.488E-02	-5.544E-02	-7.854E-03	3.268E-03	6.359E-03
S_{12}	0	3.7	-1.077E-01	2.667E-01	-4.035E-02	-5.846E-03	-2.225E-02	2.213E-03
S_{13}	0	3.7	-9.512E-01	3.384E-02	4.268E-02	5.478E-02	-3.769E-03	-2.779E-03
S_{14}	0	3.7	1.676E-01	-2.814E-01	2.307E-02	1.180E-02	-3.634E-03	-1.653E-02
S_{15}	0	3.7	8.046E-01	6.039E-02	9.548E-02	1.891E-02	8.015E-03	-7.180E-03
S_{16}	0	3.7	3.581E-01	-4.279E-02	1.900E-02	9.315E-03	1.405E-02	4.839E-03

TABLE 8

Lens #	Lens or group focal length [mm]
L1	14.88
L2	-28.15
L3	12.85
L4	-49.00
L5	65.32
L6	-9.17
L7	-32.37
L8	19.45
G1	23.01
G2	15.28
G3	-11.55

FIG. 4A shows details of the lens elements of a third embodiment of an exemplary optical design in a folded Tele camera such as camera **103** in a first zoom state, while FIG. 4B shows details of the lens elements of the third optical design in a second zoom state. The figures show a lens **114''**, image sensor **118** and optional window **130**. The third optical design is represented by Tables 9-12 and includes eight lens elements marked L1-L8, starting with L1 on an object side facing the prism and ending with L8 on an image side toward the image sensor. Table 9 provides optical data, Table 10 provides zoom data, Table 11 provides aspheric data and Table 12 provides lens or group focal length in mm.

In lens **114''**, lens elements L1-L8 are grouped into three groups: a first group G1 comprising lens elements L1 and

L2, a second group G2 comprising lens elements L3 and L4, and a third group comprising lens elements L5-L8.

In a third exemplary use ("Example 3"), the camera is brought into two zoom states by moving groups G1 and G3 relative to the image sensor in a given range while keeping group G2 stationary. The range of movement may be for example 5-10 mm. G1 is further movable for focusing. In Example 3, G1 and G3 are moved relative to G2 (and the image sensor) to bring the camera into a first zoom state shown in FIG. 4A in which $EFL_T = EFL_{Tmin} = 15$ mm, $F \#_{Tmin} = 2.74$ and $TTL_T = TTL_{Tmin} = 16.78$ mm, and into a second zoom state shown in FIG. 4B in which $EFL_T = EFL_{Tmax} = 30$ mm, $F \# = F \#_{Tmax} = 4$ and $TTL_T = TTL_{Tmax} = 26.958$ mm. In the first state, G1 is separated from G2 by a distance **d4** (the distance between S_4 and S_5 in Table 10 for a case of 15 mm EFL, i.e. 0.199-0.870 mm, depending on the focus distance), G2 is separated from G3 by a distance **d8** (the distance between S_8 and S_9 in Table 10 for a case of 15 mm EFL, i.e. 6.050 mm) and G3 is separated from window **130** by a distance **d16** (the distance between S_{16} and S_{17} in Table 10 for a case of 15 mm EFL, i.e. 0.650 mm). In the second state, G1 is separated from G2 by a distance **d4** (the distance between S_4 and S_5 in Table 10 for a case of 30 mm EFL, i.e. 10.377-11.031 mm, depending on the focus distance), G2 is separated from G3 by a distance **d8** (the distance between S_8 and S_9 in Table 10 for a case of 30 mm EFL, i.e. 0.06 mm) and G3 is separated from window **130** by a distance **d16** (the distance between S_{16} and S_{17} in Table 10 for a case of 30 mm EFL, i.e. 6.64 mm).

TABLE 9

Group	Lens	Surface	Type	R [mm]	T [mm]	Nd	Vd	D [mm]
Object		S_0	Flat	Infinity	See Table 10			
G1	L1	S_1	EVAS	5.965	1.246	1.4847	84.150	7.50
G1	L1	S_2	EVAS	14.446	2.524			7.50
G1	L2	S_3	EVAS	-18.902	0.545	1.8446	23.750	6.52
G1	L2	S_4	EVAS	-27.153	See Table 10			6.24
G2	L3	S_5	EVAS	15.497	0.881	1.5348	55.660	4.76
G2	L3	S_6	EVAS	-9.815	0.351			4.76
G2	L4	S_7	EVAS	-3.714	0.694	1.6510	21.510	4.40
G2	L4	S_8	EVAS	-4.750	See Table 10			4.27
G3	L5	S_9	EVAS	-8.318	0.535	1.6510	21.510	4.00
G3	L5	S_{10}	EVAS	-49.289	0.581			3.84
G3	L6	S_{11}	EVAS	29.648	0.492	1.6510	21.510	4.01
G3	L6	S_{12}	EVAS	-15.803	0.371			4.17
G3	L7	S_{13}	EVAS	-8.902	0.625	1.6510	21.510	4.51
G3	L7	S_{14}	EVAS	-5.204	0.066			4.66
G3	L8	S_{15}	EVAS	-4.708	0.260	1.5348	55.660	4.73
G3	L8	S_{16}	EVAS	21.740	See Table 10			4.65
Glass		S_{17}	Flat	Infinity	0.210	1.5168	64.170	
window		S_{18}	Flat	Infinity	0.500			
Image sensor		S_{19}	Flat	Infinity	0			

TABLE 10

	First zoom state $EFL_T = 15$ mm		Second zoom state $EFL_T = 30$ mm	
	at infinity	at 1 meter	at infinity	at 1 meter
Object position				
Stop surface		S8		S1
T [mm]	S_0	Infinity	1000	Infinity
	S_4	0.199	0.870	10.377
	S_8	6.050	6.050	0.060
	S_{16}	0.650	0.650	6.640

TABLE 11

Surface	Conic (k)	α_2	α_3
S1	0.522	-1.7367E-04	1.4347E-06
S2	1.931	4.4699E-04	2.3992E-05
S3	19.446	5.1529E-03	-5.1705E-05
S4	42.199	5.0933E-03	-1.1038E-05
S5	-19.929	-9.0502E-05	-2.5378E-04
S6	5.537	1.3905E-03	-2.6043E-04
S7	-0.207	7.6849E-03	-3.0619E-04
S8	0.535	5.5481E-03	-1.4016E-04
S9	-36.500	2.6433E-02	-1.9343E-03
S10	10.019	3.3334E-02	5.6299E-04
S11	-10.151	-2.4156E-02	4.1713E-03
S12	10.679	-1.3708E-02	3.1066E-03
S13	10.006	1.3443E-02	-1.0812E-03
S14	3.232	5.2907E-03	7.9836E-05
S15	1.099	6.4779E-03	1.6274E-03
S16	3.669	8.5666E-04	8.2964E-05

Lens #	Lens or group focal length [mm]
L1	19.95
L2	-75.22
L3	11.33
L4	-35.23
L5	-15.29
L6	15.73
L7	17.84
L8	-7.18
G1	25.67
G2	17.78
G3	-11.14

FIG. 4C shows details of the lens elements of a fourth exemplary optical design in a folded Tele camera such as camera **103** in a first zoom state, while FIG. 4D shows details of the lens elements of the fourth optical design in a second zoom state. The figures show a lens **114**"", image sensor **118** and optional window **130**. The fourth optical

design is represented by Tables 13-16 and includes eight lens elements marked L1-L8, starting with L1 on an object side facing the prism and ending with L8 on an image side toward the image sensor. Table 13 provides optical data, Table 14 provides zoom data, Table 15 provides aspheric data and Table 16 provides lens or group focal length in mm.

In a fourth example ("Example 4"), in lens **114**"", lens elements L1-L8 are grouped into three groups: a first group G1 comprising lens elements L1 and L2, a second group G2 comprising lens elements L3-L5, and a third group comprising lens elements L6-L8.

In Example 4, the camera is brought into two zoom states by moving groups G1 and G3 together (as one unit) relative to the image sensor in a given range $R_{1,3}$ while group G2 is stationary relative to the image sensor in the zoom process. In Example 5, $R_{1,3}=7.065$ mm. While group G2 does not move when changing zoom state, group G2 is movable at any zoom state relative to the image sensor and groups G1 and G3 in a range RA for changing the focal distance of camera **106** from infinity down to 1 meter. R_A may be up to 730 μm , depending on zoom state. FIG. 4C shows Example 4 in the first zoom state in which $EFL_T=EFL_{Tmin}=15$ mm, $F\#_T=F\#_{Tmin}=2$ and $TTL_T=TTL_{Tmin}=17.865$ mm, and FIG. 4D shows Example 4 in the second zoom state in which $EFL_T=EFL_{Tmax}=30$ mm, $F\#_T=F\#_{Tmax}=4$, and $TTL_T=TTL_{Tmax}=24.93$ mm.

In the first state, G1 is separated from G2 by a distance d4 (the distance between S_4 and S_5 in Table 14 for a case of 15 mm EFL, G2 is separated from G3 by a distance d10 (the distance between S_{10} and S_{11} in Table 14 for a case of 15 mm EFL, and G3 is separated from window **130** by a distance d16 (the distance between S_{16} and S_{17} in Table 14 for a case of 15 mm EFL. In the second state, G1 is separated from G2 by a distance d4' (the distance between S_4 and S_5 in Table 14 for a case of 30 mm EFL), G2 is separated from G3 by a distance d10' (the distance between S_{10} and S_{11} in Table 14 for a case of 30 mm EFL) and G3 is separated from window **130** by a distance d16' (the distance between S_{16} and S_{17} in Table 14 for a case of 30 mm EFL).

TABLE 13

Group	Lens	Surface	Type	R [mm]	T [mm]	Nd	Vd	D [mm]
Object		S_0	Flat	Infinity	See Table 14			
G1	L1	S_1	QT1	6.795	1.665	1.4847	84.150	7.50
G1	L1	S_2	QT1	55.652	1.690			7.28
G1	L2	S_3	QT1	38.079	0.330	1.7978	22.463	6.53
G1	L2	S_4	QT1	18.832	See Table 14			6.32
G2	L3	S_5	QT1	-14.657	0.862	1.5348	55.660	5.43
G2	L3	S_6	QT1	-5.687	0.076			5.50
G2	L4	S_7	QT1	-5.011	0.735	1.6510	21.510	5.41
G2	L4	S_8	QT1	-6.654	0.052			5.50
G2	L5	S_9	QT1	-6.344	0.813	1.5348	55.660	5.47
G2	L5	S_{10}	QT1	-5.302	See Table 14			5.51
G3	L6	S_{11}	QT1	-4.891	0.230	1.5348	55.660	4.54
G3	L6	S_{12}	QT1	-7.762	0.050			4.54
G3	L7	S_{13}	QT1	-17.929	0.230	1.5348	55.660	4.53
G3	L7	S_{14}	QT1	7.959	0.057			4.60
G3	L8	S_{15}	QT1	8.309	0.425	1.6510	21.510	4.63
G3	L8	S_{16}	QT1	21.747	See Table 14			4.65
Glass		S_{17}	Flat	Infinity	0.210	1.5168	64.170	
window		S_{18}	Flat	Infinity	0.300			
Image sensor		S_{19}	Flat	Infinity	0			

TABLE 14

		First zoom state EFL _T = 15 mm		Second zoom state EFL _T = 30 mm	
Object position		at infinity	at 1 meter	at infinity	at 1 meter
Stop surface		S1		S1	
T [mm]	S ₀	Infinity	1000	Infinity	1000
	S ₄	1.996	1.717	9.060	8.337
	S ₁₀	7.764	8.043	0.700	1.423
	S ₁₆	0.380	0.380	7.445	7.445

TABLE 15

Surface	Conic	NR	A ₀	A ₁	A ₂	A ₃	A ₄	A ₅
S ₁	0	3.7	-1.185E-02	-4.312E-04	-7.102E-05	0.000E+00	0.000E+00	0.000E+00
S ₂	0	3.7	1.691E-02	4.449E-04	-2.627E-04	0.000E+00	0.000E+00	0.000E+00
S ₃	0	3.7	2.920E-01	-1.206E-02	-1.439E-03	0.000E+00	0.000E+00	0.000E+00
S ₄	0	3.7	3.521E-01	-7.983E-03	-1.529E-03	0.000E+00	0.000E+00	0.000E+00
S ₅	0	3.7	-9.944E-01	-1.351E-01	-1.582E-02	0.000E+00	0.000E+00	0.000E+00
S ₆	0	3.7	-3.506E-01	-8.796E-03	3.480E-02	0.000E+00	0.000E+00	0.000E+00
S ₇	0	3.7	2.435E-01	7.231E-02	3.347E-02	0.000E+00	0.000E+00	0.000E+00
S ₈	0	3.7	7.927E-02	9.735E-03	2.347E-04	0.000E+00	0.000E+00	0.000E+00
S ₉	0	3.7	1.102E-01	-4.921E-02	3.957E-03	0.000E+00	0.000E+00	0.000E+00
S ₁₀	0	3.7	3.430E-02	-4.824E-02	1.267E-04	0.000E+00	0.000E+00	0.000E+00
S ₁₁	0	3.7	9.549E-01	3.565E-02	1.185E-01	0.000E+00	0.000E+00	0.000E+00
S ₁₂	0	3.7	7.134E-01	-4.530E-02	1.012E-01	0.000E+00	0.000E+00	0.000E+00
S ₁₃	0	3.7	6.795E-02	1.289E-01	2.055E-02	0.000E+00	0.000E+00	0.000E+00
S ₁₄	0	3.7	4.103E-02	2.657E-01	9.470E-02	0.000E+00	0.000E+00	0.000E+00
S ₁₅	0	3.7	2.845E-01	3.100E-01	8.796E-02	0.000E+00	0.000E+00	0.000E+00
S ₁₆	0	3.7	2.795E-01	2.231E-01	3.147E-02	0.000E+00	0.000E+00	0.000E+00

Lens #	Lens or group focal length [mm]
L1	15.76
L2	-46.69
L3	16.75
L4	-37.57
L5	47.27
L6	-25.34
L7	-10.23
L8	20.23
G1	21.49
G2	19.76
G3	-11.20

FIG. 4E shows details of the lens elements of a fifth exemplary optical design in a folded Tele camera such as camera **103** in a first zoom state, while FIG. 4F shows details of the lens elements of the fifth optical design in a second zoom state. The figures show a lens **114**''', image sensor **118** and optional window **130**. The fifth optical design is represented by Tables 17-20 and includes eight lens elements marked L1-L8, starting with L1 on an object side facing the prism and ending with L8 on an image side toward the image sensor. Table 17 provides optical data, Table 18 provides zoom data, Table 19 provides aspheric data and Table 20 provides lens or group focal length in mm.

In the fifth example ("Example 5"), in lens **114**''', lens elements L1-L8 are grouped into three groups: a first group

G1 comprising lens elements L1 and L2, a second group G2 comprising lens elements L3-L5, and a third group comprising lens elements L6-L8.

In Example 5, the camera is brought into two zoom states by moving groups G1 and G3 together (as one unit) relative to the image sensor in a given range R_{1,3} while group G2 is stationary relative to the image sensor. In Example 5, R_{1,3}=7.697 mm. Groups G1+G3 is further movable together at any zoom state relative to the image sensor and group G2 in a range RA for changing the focal distance of camera **106** from infinity down to 2 meter. RA may be up to 1.8 mm, depending on zoom state. FIG. 4E shows Example 5 in the first zoom state in which EFL_T=EFL_{Tmin}=15 mm, F #=F #_{Tmin}=2 and TTL_T=TTL_{Tmin}=18.1 mm, and FIG. 4F shows Example 5 in the second zoom state in which EFL_T=EFL_{Tmax}=30 mm, F #=F #_{Tmax}=4, and TTL_T=TTL_{Tmax}=25.8 mm.

In the first state, G1 is separated from G2 by a distance d4 (the distance between S₄ and S₅ in Table 18 for a case of 15 mm EFL), G2 is separated from G3 by a distance d10 (the distance between S₁₀ and S₁₁ in Table 18 for a case of 15 mm EFL) and G3 is separated from window **130** by a distance d16 (the distance between S₁₆ and S₁₇ in Table 18 for a case of 15 mm EFL). In the second state, G1 is separated from G2 by a distance d4' (the distance between S₄ and S₅ in Table 18 for a case of 30 mm EFL), G2 is separated from G3 by a distance d10' (the distance between S₁₀ and S₁₁ in Table 18 for a case of 30 mm EFL), and G3 is separated from window **130** by a distance d16' (the distance between S₁₆ and S₁₇ in Table 17 for a case of 30 mm EFL).

TABLE 17

Group	Lens	Surface	Type	R [mm]	T [mm]	Nd	Vd	D [mm]
Object		S ₀	Flat	Infinity	See Table 18			
G1	L1	S ₁	QT1	7.595	2.293	1.4847	84.150	7.50
G1	L1	S ₂	QT1	166.728	1.379			7.20
G1	L2	S ₃	QT1	169.765	0.381	1.7978	22.463	6.73
G1	L2	S ₄	QT1	30.296	See Table 18			6.55
G2	L3	S ₅	QT1	-19.262	0.991	1.5348	55.660	5.61
G2	L3	S ₆	QT1	-7.798	0.067			5.71
G2	L4	S ₇	QT1	-7.473	0.235	1.6510	21.510	5.62
G2	L4	S ₈	QT1	-10.037	0.178			5.63
G2	L5	S ₉	QT1	-6.776	0.896	1.5348	55.660	5.62
G2	L5	S ₁₀	QT1	-5.279	See Table 18			5.69
G3	L6	S ₁₁	QT1	-11.648	0.207	1.5348	55.660	4.95
G3	L6	S ₁₂	QT1	-16.086	0.091			4.95
G3	L7	S ₁₃	QT1	-14.227	0.203	1.5348	55.660	4.98
G3	L7	S ₁₄	QT1	8.126	0.041			5.01
G3	L8	S ₁₅	QT1	5.960	0.448	1.6510	21.510	5.03
G3	L8	S ₁₆	QT1	8.873	See Table 18			5.07
Glass window		S ₁₇	Flat	Infinity	0.210	1.5168	64.170	
		S ₁₈	Flat	Infinity	0.300			
Image sensor		S ₁₉	Flat	Infinity	0			

TABLE 18

		First zoom state EFL _T = 15 mm		Second zoom state EFL _T = 30 mm	
Object position	Stop surface	at infinity	at 2 meters	at infinity	at 2 meters
			S1		S1
T [mm]	S ₀	Infinity	2000	Infinity	2000
	S ₄	1.377	1.853	9.074	7.308
	S ₁₀	8.388	7.913	0.691	2.458
	S ₁₆	0.415	0.890	8.112	6.345

TABLE 19

Surface	Conic	NR	A ₀	A ₁	A ₂	A ₃	A ₄	A ₅
S ₁	0	3.7	-3.810E-02	-2.313E-03	-1.826E-04	0.000E+00	0.000E+00	0.000E+00
S ₂	0	3.7	-1.050E-02	6.271E-04	-4.206E-05	0.000E+00	0.000E+00	0.000E+00
S ₃	0	3.7	2.425E-01	-4.719E-03	1.605E-03	0.000E+00	0.000E+00	0.000E+00
S ₄	0	3.7	2.621E-01	-4.538E-03	1.794E-03	0.000E+00	0.000E+00	0.000E+00
S ₅	0	3.7	-7.571E-01	-2.386E-02	1.173E-02	0.000E+00	0.000E+00	0.000E+00
S ₆	0	3.7	-3.239E-01	-4.277E-02	1.470E-02	0.000E+00	0.000E+00	0.000E+00
S ₇	0	3.7	8.636E-02	-6.570E-02	-2.140E-02	0.000E+00	0.000E+00	0.000E+00
S ₈	0	3.7	1.137E-01	-5.791E-02	-2.009E-02	0.000E+00	0.000E+00	0.000E+00
S ₉	0	3.7	2.911E-01	-9.503E-02	2.344E-04	0.000E+00	0.000E+00	0.000E+00
S ₁₀	0	3.7	1.470E-01	-4.954E-02	-3.365E-03	0.000E+00	0.000E+00	0.000E+00
S ₁₁	0	3.7	3.957E-01	3.980E-01	2.043E-01	0.000E+00	0.000E+00	0.000E+00
S ₁₂	0	3.7	1.263E+00	5.363E-03	-8.070E-02	0.000E+00	0.000E+00	0.000E+00
S ₁₃	0	3.7	9.897E-01	-2.343E-01	-2.471E-01	0.000E+00	0.000E+00	0.000E+00
S ₁₄	0	3.7	-3.191E-01	-1.890E-01	-3.206E-02	0.000E+00	0.000E+00	0.000E+00
S ₁₅	0	3.7	-1.999E+00	-7.518E-01	-2.345E-01	0.000E+00	0.000E+00	0.000E+00
S ₁₆	0	3.7	-1.561E+00	-4.492E-01	-1.770E-01	0.000E+00	0.000E+00	0.000E+00

55

TABLE 20

Lens #	Lens or group focal length [mm]
L1	16.31
L2	-45.91
L3	23.68
L4	-45.03
L5	36.78
L6	-79.93
L7	-9.60
L8	26.08

60

TABLE 20-continued

Lens #	Lens or group focal length [mm]
G1	22.79
G2	21.82
G3	-12.37

FIG. 4G shows details of the lens elements of a sixth embodiment of an exemplary optical design in a folded Tele camera such as camera 103 in a first zoom state, while FIG. 4H shows details of the lens elements of the sixth optical

design in a second zoom state. The figures show a lens **114''''''**, image sensor **118** and optional window **130**. The sixth optical design is represented by Tables 21-24 and includes eight lens elements marked L1-L8, starting with L1 on an object side facing the prism and ending with L8 on an image side toward the image sensor. Table 21 provides optical data, Table 22 provides zoom data, Table 23 provides aspheric data and Table 24 provides lens or group focal length in mm.

In lens **114''''''** lens elements L1-L8 are grouped into three groups: a first group G1 comprising lens elements L1, L2 and L3, a second group G2 comprising lens elements L4, L5 and L6, and a third group comprising lens elements L7 and L8.

In Example 6, the camera is brought into two zoom states by moving groups G1 and G3 together (as one unit) relative to the image sensor in a given range $R_{1,3}$ while group G2 moves in a range R_2 relative to the image sensor, whereas $R_2 < R_{1,3}$. In Example 6, $R_{1,3} = 5.641$ mm and $R_2 = 0.718$. Groups G1+G2+G3 is further movable together at any zoom state relative to the image sensor and in a range RA for

changing the focal distance of camera **106** from infinity down to 1 meter or down to 2 meter. RA may be up to 0.4 mm, depending on zoom state.

FIG. 4G shows Example 6 in the first zoom state in which $EFL_T = EFL_{Tmin} = 13$ mm, $F \# = F \#_{Tmin} = 1.8$ and $TTL_T = TTL_{Tmin} = 19.84$ mm, and FIG. 4H shows Example 6 in the second zoom state in which $EFL_T = EFL_{Tmax} = 26$ mm, $F \# = F \#_{Tmax} = 2.88$, and $TTL_T = TTL_{Tmax} = 25.85$ mm.

In the first state, G1 is separated from G2 by a distance d7 (the distance between S_7 and S_8 in Table 22 for a case of 13 mm EFL), G2 is separated from G3 by a distance d13 (the distance between S_{13} and S_{14} in Table 22 for a case of 13 mm EFL) and G3 is separated from window **130** by a distance d17 (the distance between S_{17} and S_{18} in Table 22 for a case of 13 mm EFL). In the second state, G1 is separated from G2 by a distance d7' (the distance between S_7 and S_8 in Table 22 for a case of 26 mm EFL), G2 is separated from G3 by a distance d13' (the distance between S_{13} and S_{14} in Table 22 for a case of 26 mm EFL), and G3 is separated from window **130** by a distance d17' (the distance between S_{17} and S_{18} in Table 21 for a case of 26 mm EFL).

TABLE 21

Group	Lens	Surface	Type	R [mm]	T [mm]	Nd	Vd	D [mm]
Object		S ₀	Flat	Infinity	See Table 2			
Stop		S ₁	Flat	Infinity	-0.775			9.000
G1	L1	S ₂	QFORB type 1	17.302	1.786	1.5661	37.43	8.577
G1	L1	S ₃	QFORB type 1	62.771	0.725			8.652
G1	L2	S ₄	QFORB type 1	10.090	1.928	1.5449	55.91	8.557
G1	L2	S ₅	QFORB type 1	-23.147	0.689			8.086
G1	L3	S ₆	QFORB type 1	80.507	0.232	1.6991	19.44	8.073
G1	L3	S ₇	QFORB type 1	10.360	See Table 2			5.509
G2	L4	S ₈	QFORB type 1	-4.430	0.928	1.5449	55.91	5.543
G2	L4	S ₉	QFORB type 1	-7.104	0.144			5.555
G2	L5	S ₁₀	QFORB type 1	440.072	1.646	1.6991	19.44	6.397
G2	L5	S ₁₁	QFORB type 1	28.935	0.033			6.494
G2	L6	S ₁₂	QFORB type 1	39.391	2.010	1.5449	55.91	6.726
G2	L6	S ₁₃	QFORB type 1	-5.075	See Table 2			6.322
G3	L7	S ₁₄	QFORB type 1	-6.250	0.601	1.6991	19.44	6.435
G3	L7	S ₁₅	QFORB type 1	-4.314	0.033			6.292
G3	L8	S ₁₆	QFORB type 1	-4.226	0.553	1.5449	55.91	6.944
G3	L8	S ₁₇	QFORB type 1	45.368	See Table 2			7.179
Glass		S ₁₈	Flat	Infinity	0.21	1.5168	64.17	7.235
window		S ₁₉	Flat	Infinity	0.3			7.000
Image sensor		S ₂₀	Flat	Infinity	0			7.000

TABLE 22

Object position	First zoom state $EFL_T = 13$ mm		Second zoom state $EFL_T = 26$ mm	
	at infinity	at 1 meter	at infinity	at 2 meter
Stop surface	S8		S1	
T [mm]	S ₀	Infinity	1000	Infinity
	S ₇	1.287	1.287	6.928
	S ₁₃	6.224	6.224	0.584
	S ₁₇	0.510	0.680	6.527
				2000
				6.928
				0.584
				6.869

TABLE 23

Surface	Conic (k)	NR	A ₂	A ₂	A ₃	A ₄
S ₂	0	4.500	1.937E-01	3.246E-02	1.318E-03	2.280E-04
S ₃	0	4.500	2.594E-01	8.795E-02	5.484E-03	3.649E-03
S ₄	0	4.000	-1.694E-01	7.487E-04	-3.651E-03	1.653E-03
S ₅	0	4.000	-8.607E-02	-4.556E-02	9.328E-03	-1.115E-04

TABLE 23-continued

Surface	Conic (k)	NR	A ₂	A ₂	A ₃	A ₄
S ₆	0	4.000	-8.318E-01	8.107E-02	-3.312E-03	1.627E-04
S ₇	0	3.600	-7.475E-01	6.703E-02	-6.921E-03	5.168E-04
S ₈	0	3.540	1.184E+00	-7.816E-02	6.294E-03	-5.495E-03
S ₉	0	3.540	1.068E+00	-3.634E-02	4.046E-03	-3.309E-03
S ₁₀	0	3.540	-7.538E-01	-8.548E-02	-3.579E-02	-4.211E-03
S ₁₁	0	3.540	-3.354E-01	5.277E-03	-9.014E-03	-8.400E-04
S ₁₂	0	3.540	-6.434E-02	-5.113E-04	3.479E-04	-1.573E-03
S ₁₃	0	3.540	5.865E-03	1.176E-03	3.052E-03	5.638E-04
S ₁₄	0	3.540	-3.496E-01	-4.291E-02	-1.806E-02	-1.974E-03
S ₁₅	0	3.540	-9.519E-03	2.425E-02	-8.039E-03	-5.814E-03
S ₁₆	0	3.540	2.311E-01	7.899E-02	9.116E-03	-5.414E-03
S ₁₇	0	3.540	-2.319E-01	8.502E-03	-2.231E-04	-1.988E-04

TABLE 24

Lens #	Lens or group focal length [mm]
L1	41.40
L2	13.12
L3	-17.63
L4	-24.54
L5	-45.94
L6	8.36
L7	18.33
L8	-7.04
G1	19.31
G2	12.82
G3	-10.82

FIG. 5A-E show schematically an example for Tele lens and sensor module (or simply “module”) numbered **500**. The description of the figures continues with reference to a coordinate system XYZ shown in FIGS. 5A-E as well as in a number of other figures. In an example, module **500** has the optical design of the second example. In module **500**, an example for an actuation method required for changing between zoom states and focus states of lenses **114'**, **114''** and **114'''** is provided. FIG. 5A shows schematically module **500** in an EFL_{Tmin} state from a top perspective view, and FIG. 5B shows schematically module **500** in the EFL_{Tmin} state from another top perspective view. FIG. 5C shows schematically module **500** in an EFL_{Tmax} state from one top perspective view, and FIG. 5D shows schematically module **500** in the EFL_{Tmax} state from another top perspective view. FIG. 5E shows an exploded view of module **500**. Module **500** comprises a G1+G3 lens sub-assembly **502**, a G2 lens sub-assembly **504**, a sensor sub-assembly **506**, an electro-magnetic (EM) sub-assembly **508**, a base sub-assembly **510**, a first magnet **512**, a first coil **514**, a second magnet **516**, a first set of (exemplarily 4) balls **520** and a second set of (exemplarily 4) balls **522**. Lens sub-assemblies **502** and **504** share lens optical axis **116**.

First coil **514** is positioned next to first magnet **512** and is rigidly coupled to (not moving relative to) base sub-assembly **510**. First coil **514** may be soldered to a PCB such as PCB **822** (FIG. 8), or routed to external circuitry (not shown) which allows sending input and output currents to first coil **514**, the currents carrying both power and electronic signals required for operation. Coil **514** has exemplarily a rectangular shape and typically includes a few tens of coil windings (i.e. in a non-limiting range of 50-250), with a typical resistance of 10-30 ohm. First magnet **512** is a split magnet, such that a split line **512a** in the middle separates it into two sides: in one side of split line **512a**, magnet **512** has a north magnetic pole facing the positive X direction, and in the

other side of split line **512a**, magnet **512** has a south magnetic pole facing the positive X direction. Upon driving a current in first coil **514**, a first Lorentz force is created on first magnet **512**. In an example, a current flow through first coil **514** in a clockwise direction will induce a first Lorentz force in the positive Z direction on first magnet **512**, while a current flow through first coil **512** in a counter clockwise direction will induce a Lorentz force in the negative Z direction on first magnet **512**. In an example, first Lorentz force may be used to move bottom actuated sub-assembly **560** from the first zoom state to the second zoom state and vice-versa in an open loop control, i.e. actuate bottom actuated sub-assembly **560** between stops **720a-b** and **722a-b** (see below).

FIGS. 6A and 6B provide two bottom perspective views of actuated parts of module **500**, showing a top actuated sub-assembly **550** and a bottom actuated sub-assembly **560** in the EFL_{Tmin} state. FIG. 6C shows top actuated sub-assembly **550** from a bottom perspective view. Top actuated sub-assembly **550** comprises G2 lens sub-assembly **504**, second magnet **516** and a plurality of stepping magnets **626**. Bottom actuated sub-assembly **560** comprises G1+G3 lens sub-assembly **502**, first magnet **512**, stepping magnets **628** and four yokes **602a-b** (FIG. 6B) and **604a-b** (FIG. 6A). FIG. 7 shows details of base sub-assembly **510**, which comprises guiding rails **710a** and **710b** and pull-stop magnets **702a-b** and **704a-b**. Note that in FIG. 7, pull-stop magnets **702a-b** and **704a-b** are separated from stops **720a-b** and **722a-b** for illustration purposes. Arrows show the gluing position of pull-stop magnets **702a-b** and **704a-b** in stops **720a-b** and **722a-b**. Yokes **602a-b** are pulled against pull-stop magnets **702a-b** and yokes **604a-b** are pulled against pull-stop magnets **704a-b**. Each of guiding rails **710a-b** comprises a respective groove **712a-b**. Base sub-assembly **510** further comprises two mechanical stops **706** and **708**, which are exemplarily connected to guiding rail **710b**. Mechanical stops **706** and **708** limit the stroke of top actuated sub-assembly **550**. FIG. 8 shows details of EM sub-assembly **508** on PCB **822**.

In an example, module **500** enables a relative motion of lens sub-assemblies **502** and **504** in a direction along lens optical axis **116**. Module **500** has exemplary length/width/height dimensions in the range of 3-40 mm, i.e. module **500** can be contained in a box with dimension of $3 \times 3 \times 3 \text{ mm}^3$ to $40 \times 40 \times 40 \text{ mm}^3$. In an example, module **500** has a height (along Y axis) which is limited by the maximal clear apertures of lens elements L1 . . . LN plus the plastic thickness of respective lens sub-assemblies **502** and **504** (the plastic thickness is for example in the range 0.5-1.5 mm), plus the thickness of shield **107** (the shield thickness is for

example in the range 0.1-0.3 mm), plus the thickness of two airgaps between respective lens sub-assemblies **502** and **504** and shield **107** (each air gap thickness is for example in the range of 0.05-0.15 mm). The clear aperture of lens elements L1 . . . LN may be a circular or cut-lens clear aperture, as described below.

In module **500**, the three lens groups (G1, G2 and G3) are held in two lens sub-assemblies: lens sub-assembly **502** that holds lens groups G1+G3 and lens sub-assembly **504** that holds lens group G2. Lens sub-assemblies **502** and **504** are typically made of plastic. In some embodiments, lens sub-assembly **502** and lens groups G1+G3 may be a single part (and similarly lens sub-assembly **504** and G2 may be a single part). In some embodiments, they may be separate parts. Lens sub-assemblies **502** and **504** may be made, for example, by plastic molding, or alternatively by other methods. First and second magnets **512** and **516** are fixedly attached (e.g. glued) to lens sub-assemblies **502** and **504**, respectively, from two opposite sides across lens optical axis **116** (X direction).

Lens sub-assembly **502** includes several grooves, defining a mechanical ball-guided mechanism, allowing actuation in a linear rail for the zoom needs. In this example, six grooves are described, but another number of grooves may be used: two grooves **542a-b** (FIG. 5E) on a top surface of lens sub-assembly **502** along the Z direction, and four grooves **624a-d** (FIG. 6A) on a bottom surface of lens sub-assembly **502**, along the Z direction as well. Lens sub-assembly **504** includes several grooves, mating with some of the grooves of lens sub-assembly **502**. In the embodiment shown, lens sub-assembly **504** includes four grooves **642a-d**, only three of which are seen in FIG. 6C. Grooves **642a-d** are parallel to each other, are along the Z-axis (optical axis), and are used to guide top actuated sub-assembly **550** along the Z direction.

Top actuated sub-assembly **550** is positioned on top of bottom actuated sub-assembly **560** such that grooves **642a-b** (**642c-d**) are right above and parallel to grooves **542a** (**542b**).

In the embodiment shown, four balls **520** are positioned on top of grooves **542a-b** (two balls on top of each groove) and below grooves **642a-d** (FIG. 6C), such that balls **520** separate lens sub-assembly **502** and lens sub-assembly **504** and prevent the two parts from touching each other. In other embodiments, module **500** may have more than four balls between lens sub-assemblies **502** and **504**, for example up to 7 balls per side or up to 14 balls in total. Balls **520** may be made from aluminum oxide or another ceramic material, from a metal or from a plastic material. Typical ball diameters may be in a non-limiting range of 0.3-1 mm. Other ball sizes and positioning considerations may be, as in co-owned international PCT patent application PCT/IB2017/052383 titled "Rotational Ball Guided Voice Coil Motor".

Since lens sub-assemblies **502** and **504** are exemplarily plastic molded, there is some tolerance allowed in part dimensions, typically a few tens of microns or less for each dimension. This tolerance may lead to positional misalignment between adjacent (facing) grooves **542a-b** and **642a-d**. To better align the grooves, some grooves (e.g. **542a-b** and **642c-d**) may be V-shaped, i.e. have a V cross section shape to ensure ball positioning, while grooves **642a-b** may have a wider, trapezoid cross-section. Grooves **542b** and **642c-d** are aligned during assembly, while the alignment of grooves **542a** and **642a-b** have a small clearance due to the trapezoid cross section of the latter grooves. The trapezoid groove cross sections are just exemplary, and other groove cross section shapes may be used (e.g. rectangular, flat, etc.), such

that one pair of grooves is well aligned by the groove shape and the other pair of grooves has clearance of alignment.

The design presented herein may allow accurate alignment of the three lens element groups. G1 and G3 are well aligned to each other since they are mechanically fixed to the same part and may maintain alignment during product lifecycle. In some embodiments, lens sub-assembly **504** is molded as one part and the alignment of G1 to G3 is based on the plastic molding tolerances. In some embodiments lens sub-assembly **504** is molded as several parts which are glued in the factory using active or passive alignment procedures. G2 is aligned to G1 and G3 using a single groove pair (**542b** and **642c** and/or **642d**), i.e. lens sub-assemblies **502** and **504** are aligned to each other without intermediate parts.

Four balls **522** are positioned on top of grooves **712a-b** (two balls on top of each groove) and below grooves **624a-d** such that balls **522** separate lens sub-assembly **502** from base sub-assembly **510** and prevent the two parts from touching each other. In other embodiments, module **500** may have more than four balls, for example up to 7 balls per side or up to 14 balls in total. The size, material and other considerations related to balls **522** are similar to those of balls **520**. Other considerations regarding grooves **712a-b** and **624a-d** are similar to those of grooves **542a-b** and **642a-d** as described above.

Module **500** further includes several ferromagnetic yokes **716** (FIG. 7) fixedly attached (e.g. glued) to base sub-assembly **510** such that each yoke is positioned below (along Y direction) three of stepping magnets **626** and **628**. In other embodiments, ferromagnetic yokes **716** may be a fixedly part of shield **107**. In yet other embodiments, shield **107** by itself may be made from ferromagnetic material, or the bottom part of shield **107** may be made of ferromagnetic material, such that the yoke(s) is (are) part of the shield. Each ferromagnetic yoke **716** pulls some of stepping magnets **626** or **628** by magnetic force in the negative Y direction, and thus all yokes prevent both top actuated sub-assembly **550** and bottom actuated sub-assembly **560** from detaching from each other and from base **510** and shield **107**. Balls **520** prevent top actuated sub-assembly **550** from touching bottom actuated sub-assembly **560** and balls **522** prevent bottom actuated sub-assembly **560** from touching base sub-assembly **510**. Both top actuated sub-assembly **550** and bottom actuated sub-assembly **560** are thus confined along the Y-axis and do not move in the Y direction. The groove and ball structure further confines top actuated sub-assembly **550** and bottom actuated sub-assembly **560** to move only along lens optical axis **116** (Z-axis).

FIG. 7 shows details of base sub-assembly **510** and stationary rails in module **500**. Along the Z direction, top actuated sub-assembly **550** is limited to move between mechanical stops **706** and **708**, with a distance equal to the required stroke of G2 (about 1-3 mm) between them. Also, along the Z direction, bottom actuated sub-assembly **560** is limited to move between mechanical stops **720a-b** and **722a-b**, and/or pull-stop magnets **702a-b** and **704a-b**.

FIG. 8 shows details of EM sub-assembly **508** in module **500**. EM sub-assembly **508** includes second coil **818**, two Hall bar elements ("Hall sensors") **834a** and **834b** and a PCB **822**. Second Coil **818** and Hall bar elements **834a-b** may be soldered (each one separately) to PCB **822**. Second Coil **818** has exemplarily a rectangular shape and typically includes a few tens of coil windings (e.g. in a non-limiting range of 50-250), with a typical resistance of 10-40 ohms. PCB **822** allows sending input and output currents to second coil **818** and to Hall bar elements **834a-b**, the currents carrying both

power and electronic signals required for operation. PCB **822** may be connected electronically to the external camera by wires (not shown). In an example (FIG. **5E**), EM sub-assembly **508** is positioned next to second magnet **516**. Second magnet **516** is a split magnet, separated by a split line **516a** in the middle into two sides: in one side of split line **516a**, magnet **516** has a north magnetic pole facing the positive X direction, and in the other side of split line **516a**, magnet **516** has a south magnetic pole facing the positive X direction. Upon driving a current in second coil **818**, a Lorentz force is created on second magnet **516**. In an example, a current flow through second coil **818** in a clockwise direction will induce a Lorentz force in the positive Z direction on second magnet **516**, while a current flow through second coil **818** in a counter clockwise direction will induce a Lorentz force in the negative Z direction on second magnet **516**.

Hall bar elements **834a-b** are designed to measure magnetic the field in the X direction (intensity and sign) in the center of each Hall bar element. Hall bar elements **834a-b** can sense the intensity and direction of the magnetic field of second magnet **516**. In an example, the positioning of Hall bar element **834a** on PCB **822** is such that:

1. In the X direction, both Hall bar elements **834a** and **834b** are separated from magnet **516** by a distance (e.g. 0.1-0.5 mm), the distance being constant while magnet **516** is moving for zoom or focus needs.
2. When the system is in a first zoom state ($EFL_T=15$ mm), Hall bar element **834a** is close to split line **516a** along the Z direction. For example, for all focus positions in the first state zoom (infinity to 1 meter macro continuously), Hall element **834a** is distanced along the Z direction from split line **516a** by up RA.
3. When the system is in a second zoom state ($EFL_T=30$ mm), Hall bar element **834b** is close to split line **516a** along the Z direction. For example, for all focus positions in the first state zoom (infinity to 1 meter macro continuously), Hall element **834b** is distanced along the Z direction from split line **516a** by up RA.

In such a positioning scheme, Hall bar element **834a** can measure the respective position of second magnet **516** along the Z direction when the system is in the first zoom state, since in the first zoom state the X direction magnetic field has measurable gradient on Hall bar **834a** trajectory along R_{AF} between focus positions of infinity to 1 meter focus, and X direction magnetic field may be correlated to position. In addition Hall bar element **834b** can measure the respective position of second magnet **516** along the Z direction when the system is in the second zoom state, since in the second zoom state the X direction magnetic field has measurable gradient on Hall bar **834b** trajectory along RA between focus positions of infinity to 1 meter focus, and X direction magnetic field may be correlated to position. A control circuit (not shown) may be implemented in an integrated circuit (IC) to control in closed loop the position of second magnet **516** relative to EM sub-assembly **508** (and to base sub-assembly **510** to which EM sub-assembly **508** is rigidly coupled) while operating in either zoom states, and in open loop while traveling between zoom state (see FIG. **10** and description below) In some cases, the IC may be combined with one or both Hall elements **834a-b**. In other cases, the IC may be a separate chip, which can be located outside or inside module **500** (not shown). In exemplary embodiments, all electrical connections required by module **500** are connected to EM sub-assembly **508**, which is stationary relative

to base sub-assembly **510** and to the external world. As such, there is no need to transfer electrical current to any moving part.

The magneto-electrical design of module **500** allows the following method of operation for operating folded Tele camera **103**. FIG. **10** illustrates such an exemplary method in a flow chart. In step **1002**, Tele camera **103** is positioned with lens **114** in one (e.g. a first) zoom state. A decision (by a user or an algorithm) to refocus Tele lens **114** is made in step **1004**, and G2 lens sub-assembly **504** is moved in step **1006** under closed loop control (by a controller—not shown) using inputs from Hall bar element **834a** to bring Tele camera **103** into another focus position in the first zoom state. A decision (by a user or an algorithm) to change the zoom state of lens **114** of camera **103** to another (e.g. a second) zoom state is made in step **1008**, and G1+G3 lens sub-assembly **502** is moved under open loop control to mechanical stop **720** in step **1010**, followed by movement of G2 lens sub-assembly **504** under open loop control to mechanical stop **706** in step **1012**. G2 lens sub-assembly **504** is then moved under closed loop control using inputs from Hall bar element **834b** in step **1014**, to bring Tele folded camera **103** into the second zoom state in yet another focus position in step **1016**. A decision to refocus lens **114** is made in step **1018**. The refocusing of lens **114** in the second zoom state is performed by moving G2 lens sub-assembly under closed loop control using inputs from Hall bar element **834b**. A decision (by a user or an algorithm) to change the second zoom state of lens **114** of camera **103** to the first zoom state is made in step **1020**, and G1+G3 lens sub-assembly **502** is moved under open loop control to mechanical stop **722** in step **1022**, followed by movement of G2 lens sub-assembly **504** under open loop control to mechanical stop **708** in step **1024**.

In some embodiments, the two surfaces S_{2i-1} , S_{2i} of any lens element L_i may have two apertures that include two cuts (facets). In such a case, lens element L_i is referred to as a “cut lens element”. The cuts enable the lens assembly to be lower and/or shorter. In an example, FIG. **9A** shows a lens element **902** having axial symmetry and a height H_{902} , and FIG. **9B** shows a cut lens element **904** with two cuts **906** and **908** and with height H_{904} . Lens elements **902** and **904** have the same diameter D . Evidently $H_{904} < H_{902}$. In an example shown in FIG. **5**, the first two lens elements (L_1 and L_2) are cut lens elements.

As explained below, a clear height value $CH(S_k)$ can be defined for each surface S_k for $1 \leq k \leq 2N$, and a clear aperture value $CA(S_k)$ can be defined for each surface S_k for $1 \leq k \leq 2N$. $CA(S_k)$ and $CH(S_k)$ define optical properties of each surface S_k of each lens element.

As shown in FIGS. **11A**, **11B** and **12**, each optical ray that passes through a surface S_k (for $1 \leq k \leq 2N$) impinges this surface on an impact point IP. Optical rays enter the lens module (e.g. **114'**, **114''**, **114'''**) from surface S_1 , and pass through surfaces S_2 to S_{2N} consecutively. Some optical rays can impinge on any surface S_k but cannot/will not reach image sensor **118**. For a given surface S_k , only optical rays that can form an image on image sensor **118** are considered forming a plurality of impact points IP are obtained. $CH(S_k)$ is defined as the distance between two closest possible parallel lines (see lines **1200** and **1202** in FIG. **12** located on a plane P orthogonal to the optical axis of the lens elements (in the representation of FIGS. **11A** and **11B**, plane P is parallel to plane X-Y and is orthogonal to optical axis **116**), such that the orthogonal projection IP_{orth} of all impact points

IP on plane P is located between the two parallel lines. $CH(S_k)$ can be defined for each surface S_k (front and rear surfaces, with $1 \leq k \leq 2N$).

The definition of $CH(S_k)$ does not depend on the object currently imaged, since it refers to the optical rays that “can” form an image on the image sensor. Thus, even if the currently imaged object is located in a black background which does not produce light, the definition does not refer to this black background since it refers to any optical rays that “can” reach the image sensor to form an image (for example optical rays emitted by a background which would emit light, contrary to a black background).

For example, FIG. 11A illustrates the orthogonal projections $IP_{orth,1}$, $IP_{orth,2}$ of two impact points IP_1 and IP_2 on plane P which is orthogonal to optical axis 116. By way of example, in the representation of FIG. 11A, surface S_k is convex.

FIG. 11B illustrates the orthogonal projections $IP_{orth,3}$, $IP_{orth,4}$ of two impact points IP_3 and IP_4 on plane P. By way of example, in the representation of FIG. 3B, surface S_k is concave.

In FIG. 12, the orthogonal projection IP_{orth} of all impact points IP of a surface S_k on plane P is located between parallel lines 1200 and 1202. $CH(S_k)$ is thus the distance between lines 1200 and 1202.

Attention is drawn to FIG. 13. According to the presently disclosed subject matter, a clear aperture $CA(S_k)$ is defined for each given surface S_k (for $1 \leq k \leq 2N$), as the diameter of a circle, wherein the circle is the smallest possible circle located in a plane P orthogonal to the optical axis 116 and encircling all orthogonal projections IP_{orth} of all impact points on plane P. As mentioned above with respect to $CH(S_k)$, it is noted that the definition of $CA(S_k)$ also does not depend on the object which is currently imaged.

As shown in FIG. 13, the circumscribed orthogonal projection IP_{orth} of all impact points IP on plane P is circle 1300. The diameter of this circle 1300 defines $CA(S_k)$.

In conclusion, zoom cameras disclosed herein are designed to overcome certain optical challenges as follows:

A lens design where $EFL_{Tmax} > 1.8 \times EFL_{Tmin}$ or $EFL_{Tmax} > 1.5 \times EFL_{Tmin}$ insures significant user experience effect to the mechanical zoom.

In some embodiments (e.g. Example 1), $TTL_{Tmax} < EFL_{Tmax}$. In some embodiments (e.g. Examples 2 and 3), $TTL_{Tmax} < 0.9 \times EFL_{Tmax}$. Such a lens design may reduce camera length (along the Z axis).

In some embodiments (Examples 1-3), the first lens element has a clear aperture (diameter of S_1) larger than that of all other lens element clear apertures. In some embodiments (module 500), the first lens has a first lens which is cut lens element, see FIG. 9. Advantageously such a lens design helps to achieve small camera height.

Change in zoom state is caused by no more than two actual amounts of lens group movements. That is, to change zoom state, some lens element groups move

together in a first movement range, then some of the remaining lens group elements move together by in a second movement range and all other lens element groups do not move. This simplifies actuator control and design, since there is a need to move and control only two mechanical elements.

In some examples, $F \#_{Tmin} < 1.5 \times F \#_{Tmax} \times EFL_{Tmin} / EFL_{Tmax}$. In some examples, $F \#_{Tmin} < 1.2 \times F \#_{Tmax} \times EFL_{Tmin} / EFL_{Tmax}$. Such a lens design may achieve low F # for the first state.

In some examples, for any lens element group, the movement from the first zoom state to the second zoom state has a stroke smaller than $0.75 \times (EFL_{Tmax} - EFL_{Tmin})$. In some examples, for any lens element group, the movement from the first zoom state to the second zoom state has a stroke smaller than $0.6 \times (EFL_{Tmax} - EFL_{Tmin})$. Such a lens design may limit lens elements movement and/or simplify actuation.

Focusing can be performed by further movement of one of the lens element groups that moves together for zoom state change, simplifying actuator design and improving control.

In terms of properties of lenses disclosed herein: a lens design with 3 lens groups minimizes lens complexity.

a lens design with lens groups having (starting from the object side) positive, positive and negative power, may contribute to a small lens group movement for zoom state change.

In one example (Example 1) of a process to change zoom state, the first lens element group G1 moves by a first amount and the third lens element group G3 moves by a second amount, while the second lens element group G2 does not move. Farther movement of G3 can be used for focusing.

In another example (Example 2) of a process to change zoom state, G1 together with G3 move by a first amount and G2 moves by a second amount. Farther movement of G2 can be used for focusing.

In yet another example (Example 3) of a process to change zoom state, G1 moves by a first amount, G3 moves by a second amount and G2 does not move. Further movement of first G1 can be used for focusing.

In yet another example (Example 4) of a process to change zoom state, G1 together with G3 move and G2 does not move. Further movement of first G2 can be used for focusing.

In yet another example (Example 5) of a process to change zoom state, G1 together with G3 move and G2 does not move. Further movement of G1 together with G3 can be used for focusing.

In yet another example (Example 6) of a process to change zoom state, G1 together with G3 move by a first amount and G2 moves by a second amount. Further movement of all three lens groups together, so G1 and G2 and G3 moving together, can be used for focusing.

Table 25 summarizes the movements in each Example, with exemplary movement ranges:

TABLE 25

	Example 1	Example 2	Example 3	Example 4	Example 5	Example 6
G1 range [mm]	11.272	7.52	10.18	7.065	7.697	5.641
G2 range [mm]	Static	1.575	Static	Static	Static	0.718

TABLE 25-continued

	Example 1	Example 2	Example 3	Example 4	Example 5	Example 6
G3 range [mm]	5.02	7.52	6.0	7.065	7.697	5.641
Group moving for focus	G3	G2	G1	G2	G1 + G3	G1 + G2 + G3
AF max range [mm]	0.375	0.525	0.68	0.723	1.742	0.342

Examples presented in Table 25 where more than one lens group is indicated as moving for focus may refer to a design where the lens groups defined in the table move together as one unit for focus. In some embodiments (e.g. Examples 5 and 6), moving several lens groups together may be facilitated by coupling the respective lens groups rigidly.

The values given in G1 range, G2 range and G3 range refer to the maximal range of overall movement of the lens groups with respect to the image sensor.

The values given in row "AF max range" refer to the maximal range of movement of the lens groups with respect to the image sensor defined in row "Group moving for focus" required for focusing between infinity and 1 meter or 2 meter according to the respective relevant table of table 2, 6, 10, 14, 18, 22 see above. In most embodiments, the AF max range is given by the lens group movement for the higher zoom state, i.e. the state with EFL_{Tmax} .

In some embodiments, G1 and G3 may be in a stationary state, i.e. G1 and G3 do not move, whereas G2 may be moved in order to change zoom state.

FIG. 14 shows schematically an embodiment of an electronic device numbered 1400 and including multi-aperture cameras with at least one multi-zoom state camera disclosed herein. Electronic device 1400 comprises a first camera module 1410 that includes an OPFE 1412, and a first lens module 1414 that forms a first image recorded by a first image sensor 1416. A first lens actuator 1418 may move lens module 1414 for focusing and/or optical image stabilization (OIS) and/or for changing between two different zoom states. In some embodiments, electronic device 1400 may further comprise an application processor (AP) 1440. In some embodiments, a first calibration data may be stored in a first memory 1422 of a camera module, e.g. in an EEPROM (electrically erasable programmable read only memory). In other embodiments, a first calibration data may be stored in a third memory 1450 such as a NVM (non-volatile memory) of the electronic device 1400. The first calibration data may include one or more subsets of calibration data, e.g. a first subset comprising calibration data between sensors of a Wide and a Tele camera in a first zoom state, and/or a second subset comprising calibration data between sensors of a Wide and a Tele camera in a second zoom state, and/or a third subset comprising calibration data between a sensor of a Tele camera in a first zoom state and the same sensor in a second zoom state. Electronic device 1400 further comprises a second camera module 1430 that includes a second lens module 1432 that forms an image recorded by a second image sensor 1434. A second lens actuator 1436 may move lens module 1432 for focusing and/or OIS and/or for changing between two different zoom states. In some embodiments, second calibration data may be stored at a second memory 1438 of a camera module. In other embodiments, the second calibration data may be stored in a third memory 1450 of the electronic device 1400.

The second calibration data may include one or more subsets of calibration data, e.g. as described above.

In use, a processing unit such as AP 1440 may receive respective first and second image data from camera modules 1410 and 1430 and supply camera control signals to the camera modules 1410 and 1430. In some embodiments, AP 1440 may receive calibration data from a third memory 1450. In other embodiments, an AP 1440 may receive calibration data stored respective in a first memory located on camera module 1410 and in a second memory located on camera module 1430. In yet another embodiment, AP 1440 may receive calibration data stored respective in a first memory located on camera module 1410 and in a second memory located on camera module 1430, as well as from a third memory 1450 of an electronic device 1400. In some embodiments, an electronic device like device 1400 may comprise more than one camera module realized in a folded lens design and with an OPFE. In other embodiments, two or more camera modules may be realized without an OPFE and not with a folded lens design structure, but with another lens design structure. AP 1440 may have access to data stored in third memory 1450. This data may comprise a third calibration data. An image generator 1444 may be a processor configured to output images based on calibration data and image data. Image generator 1444 may process a calibration data and an image data in order to output an output image.

Camera calibration data may comprise:

Stereo calibration data between camera modules 1410 and 1430, specifically for all possible combinations of different lenses and different lens zoom states, e.g. of two different zoom states of a Tele camera. The stereo calibration data may include 6 degrees of freedom, e.g. pitch, yaw and roll angles, and decenter in x, y and z axes.

Stereo calibration data between camera modules 1410 and 1430, specifically for all possible combinations of different zoom states, e.g. of two different zoom states of a Tele camera. These data may include 6 degrees of freedom.

Intrinsic camera parameters, such as focal length and distortion profile for each camera module and for each of the different zoom states, e.g. of two different zoom states of a Tele camera.

Hall-sensor position values that may correspond to different focus positions in each of the different zoom states (e.g. infinity, 1 m and closest focus).

Lens shading profiles of the lens modules for each of the different zoom states.

FIG. 15A shows schematically an embodiment of a dual-aperture zoom camera with auto-focus AF and numbered 1500, in a general isometric view, and a sectioned isometric view. Camera 1500 comprises two sub-cameras, labeled 1502 and 1504, each sub-camera having its own optics. Thus, sub-camera 1502 includes an optics bloc 1506 with an

aperture **1508** and an optical lens module **1510**, as well as a sensor **1512**. Similarly, sub-camera **1504** includes an optics bloc **1514** with an aperture **1516** and an optical lens module **1518**, as well as a sensor **1520**. Each optical lens module may include several lens elements as well as an Infra-Red (IR) filter **1522a** and **1522b**. Optionally, some or all of the lens elements belonging to different apertures may be formed on the same substrate. The two sub-cameras are positioned next to each other, with a baseline **1524** between the center of the two apertures **1508** and **1516**. Each sub-camera can further include an AF mechanism and/or a mechanism for optical image stabilization (OIS), respectively **1526** and **1528**, controlled by a controller (not shown).

FIG. **15B** shows schematically an embodiment of a zoom and auto-focus dual-aperture camera **1530** with folded Tele lens in a sectioned isometric view related to a XYZ coordinate system. Camera **1530** comprises two sub-cameras, a Wide sub-camera **1532** and a Tele sub-camera **1534**. Wide camera **1532** includes a Wide optics bloc with a respective aperture **1538** and a lens module **1540** with a symmetry (and optical) axis **1542** in the Y direction, as well as a Wide image sensor **1544**. Tele camera **1534** includes a Tele optics bloc with a respective aperture **1548** and an optical lens module **1550** with a Tele lens symmetry (and optical) axis **1552a**, as well as a Tele sensor **1554**. Camera **1530** further comprises an OPFE **1556**. The Tele optical path is extended from an object (not shown) through the Tele lens to the Tele sensor and marked by arrows **1552b** and **1552a**. Various camera elements may be mounted on a substrate **1562** as shown here, e.g. a printed circuit board (PCB), or on different substrates (not shown).

FIG. **15C** shows schematically an embodiment in a general isometric view of a zoom and auto-focus triple-aperture camera **1570** with one folded Tele sub-camera **1534**. Camera **1570** includes for example elements and functionalities of camera **1530**. That is, camera **1570** includes a Wide sub-camera **1532**, a Tele sub-camera **1534** with an OPFE **1556**. Camera **1570** further includes a third sub-camera **1572** which may be an Ultra-Wide camera with an Ultra-Wide lens **1574** and an image sensor **1578**. In other embodiments, third sub-camera **1572** may have an EFL_M and a FOV_M intermediate to those of the Wide and Tele sub-cameras. A symmetry (and optical) axis **1576** of the third sub-camera is substantially parallel to axis **1542** sub-camera **1532**. Note that while the first and the third sub-cameras are shown in a particular arrangement (with third sub-camera **1572** closer to Tele sub-camera **1534**), this order may be changed such that the Wide and the Ultra-Wide sub-cameras may exchange places.

While this disclosure describes a limited number of embodiments, it will be appreciated that many variations, modifications and other applications of such embodiments may be made. In general, the disclosure is to be understood as not limited by the specific embodiments described herein, but only by the scope of the appended claims.

All references mentioned in this specification are herein incorporated in their entirety by reference into the specification, to the same extent as if each individual reference was specifically and individually indicated to be incorporated herein by reference. In addition, citation or identification of any reference in this application shall not be construed as an admission that such reference is available as prior art to the present application.

What is claimed is:

1. A camera, comprising: a lens with an optical axis, an image sensor and an optical path folding element (OPFE), wherein the lens includes, from an object side to an image

side, a first lens element group G1, a second lens element group G2 and a third lens element group G3, wherein G1 and G3 are movable along the optical axis as one unit relative to the image sensor and G2 in a given range $R_{1,3}$, wherein G2 is movable along the optical axis relative to the image sensor in a range R_2 smaller than $R_{1,3}$, wherein the combined movements of G1, G2 and G3 bring the lens to two zoom states, wherein an effective focal length (EFL) of the lens is changed from a value EFL_{min} in a minimum zoom state to a value EFL_{max} in a maximum zoom state, wherein $EFL_{max} > 1.5 \times EFL_{min}$, and wherein for any lens element group, the movement from the minimum zoom state to the maximum zoom state has a movement range smaller than $0.6 \times (EFL_{max} - EFL_{min})$.

2. The camera of claim 1, wherein G1 has a positive refractive power, G2 has a positive refractive power and G3 has a negative refractive power.

3. The camera of claim 1, wherein the lens is configured to focus by having lens element groups G1, G2 and G3 being moved together relative to the image sensor.

4. The camera of claim 1, wherein the lens has a total track length TTL and wherein a maximal value of TTL (TTL_{max}) fulfills the condition $TTL_{max} < EFL_{max}$.

5. The camera of claim 1, wherein the lens has a total track length TTL and wherein a maximal value of TTL (TTL_{max}) fulfills the condition $TTL_{max} < 0.9 \times EFL_{max}$.

6. The camera of claim 1, wherein the lens has a f-number (F #) and wherein a minimal value of F # ($F \#_{min}$) and a maximal value of F # ($F \#_{max}$) fulfill the condition $F \#_{min} < 1.5 \times F \#_{max} \times EFL_{min} / EFL_{max}$.

7. The camera of claim 1, wherein the lens has a f-number ($F \#_T$) and wherein a minimal value of F # ($F \#_{min}$) and a maximal value of F # ($F \#_{max}$) fulfill the condition $F \#_{min} < 1.8 \times F \#_{max} \times EFL_{min} / EFL_{max}$.

8. The camera of claim 1, wherein the lens has a lens f-number ($F \#_T$) and wherein a minimal value of F # ($F \#_{min}$) and a maximal value of F # ($F \#_{max}$) fulfill the condition $F \#_{min} < 1.2 \times F \#_{max} \times EFL_{min} / EFL_{max}$.

9. The camera of claim 1, wherein a first lens element L1 of the lens toward the object side has a clear aperture value larger than clear aperture values of all other lens elements of the lens.

10. The camera of claim 1, wherein $EFL_{min} = 10-20$ mm and $EFL_{max} = 20-40$ mm.

11. The camera of claim 10, wherein first lens element L1 is a cut lens element.

12. The camera of claim 1, wherein $EFL_{min} = 15$ mm and $EFL_{max} = 30$ mm.

13. The camera of claim 1, wherein G1 and G3 are movable toward the object side when switching from the minimum zoom state to the maximum zoom state.

14. The camera of claim 1, wherein, at the two zoom states, R_{AF} is a maximal range of movement of G2 required for focus between infinity and 1 meter, and wherein $R_{AF} < 0.4 \times R_2$.

15. The camera of claim 1, wherein actuation for the movement of G2 is performed in close loop control.

16. The camera of claim 15, wherein actuation for the movement of G1 and G3 is performed in open loop control.

17. The camera of claim 1, wherein the movement of G1, G2 and G3 is created using voice coil motor mechanisms.

18. The camera of claim 1, wherein the movement of G1, G2 and G3 is guided along the optical axis by a ball guided mechanism that creates a linear rail.

19. The camera of claim 18, wherein the ball guided mechanism includes at least one groove on a G2 lens carrier, at least one groove on a G1+G3 lens carrier, and a plurality

37

of balls positioned between the at least one groove on the G2 lens carrier and the at least one groove on the G1+G3 lens carrier.

20. A smartphone comprising the camera of claim 1.

* * * * *

5

38