

US011465413B2

(12) **United States Patent**
Shinkawa

(10) **Patent No.:** **US 11,465,413 B2**
(45) **Date of Patent:** **Oct. 11, 2022**

(54) **HEAD UNIT CONTROL DEVICE, HEAD UNIT, AND LIQUID EJECTION DEVICE**

10,308,021	B2	6/2019	Nomura et al.
10,960,665	B2	3/2021	Nomura et al.
2002/0163963	A1	11/2002	Moote et al.
2004/0227782	A1	11/2004	Shinkawa et al.
2007/0279449	A1*	12/2007	Mori B41J 2/0455 347/20
2009/0189933	A1*	7/2009	Nakano B41J 2/16579 347/19

(71) Applicant: **SEIKO EPSON CORPORATION**, Tokyo (JP)

(72) Inventor: **Osamu Shinkawa**, Nagano (JP)

(73) Assignee: **Seiko Epson Corporation**, Tokyo (JP)

(*) Notice: Subject to any disclaimer, the term of this patent is extended or adjusted under 35 U.S.C. 154(b) by 54 days.

(Continued)

FOREIGN PATENT DOCUMENTS

CN	1753788	A	3/2006
CN	104441991	A	3/2015

(Continued)

(21) Appl. No.: **17/133,827**

(22) Filed: **Dec. 24, 2020**

(65) **Prior Publication Data**
US 2021/0197560 A1 Jul. 1, 2021

(30) **Foreign Application Priority Data**
Dec. 26, 2019 (JP) JP2019-235447

(51) **Int. Cl.**
B41J 2/045 (2006.01)
B41J 2/14 (2006.01)

(52) **U.S. Cl.**
CPC **B41J 2/04588** (2013.01); **B41J 2/04508** (2013.01); **B41J 2/04541** (2013.01); **B41J 2/04581** (2013.01); **B41J 2/14201** (2013.01)

(58) **Field of Classification Search**
CPC B41J 2/0451
See application file for complete search history.

(56) **References Cited**
U.S. PATENT DOCUMENTS

4,907,013	A	3/1990	Hubbard et al.
6,454,377	B1	9/2002	Ishizaki

Primary Examiner — Shelby L Fidler
(74) *Attorney, Agent, or Firm* — Global IP Counselors, LLP

(57) **ABSTRACT**

A head unit control device that controls a head unit including a plurality of ejection portions that includes a first ejection portion and a second ejection portion and a determination portion that determines a liquid ejection state of the first and second ejection portion, and includes a reception portion that receives, as one data set, determination result information including first determination information indicating a determination result of the liquid ejection state of the first ejection portion from the determination portion and second determination information indicating a determination result of the liquid ejection state of the second ejection portion from the determination portion, and ejection portion information including information indicating the number of the plurality of ejection portions included in the head unit, from the head unit, and an ejection control portion that controls the plurality of ejection portions based on the one data set received by the reception portion.

9 Claims, 17 Drawing Sheets

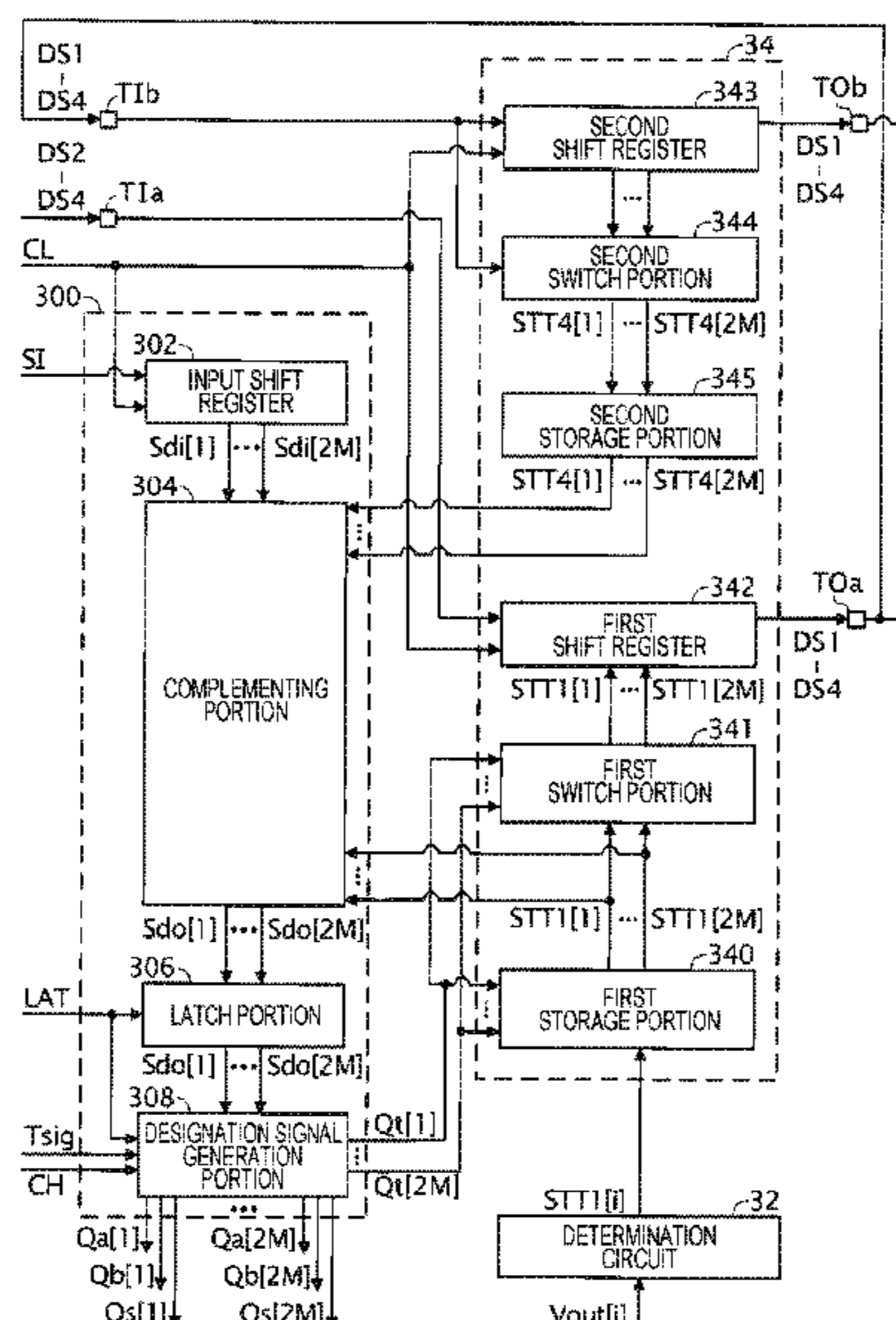

(56)

References Cited

U.S. PATENT DOCUMENTS

2010/0100799	A1	4/2010	Kurachi et al.	
2010/0149239	A1	6/2010	Sheahan et al.	
2015/0077463	A1	3/2015	Hosokawa	
2015/0170008	A1	6/2015	Hashizume	
2015/0191017	A1*	7/2015	Matsumoto	B41J 2/0451 347/22
2017/0001433	A1	1/2017	Anderson et al.	
2019/0009531	A1	1/2019	Furukawa	
2019/0202203	A1	7/2019	Suzuki	

FOREIGN PATENT DOCUMENTS

CN	204659202	U	9/2015
CN	205220090	U	5/2016
JP	2016-049691	A	4/2016
JP	2019-119192	A	7/2019

* cited by examiner

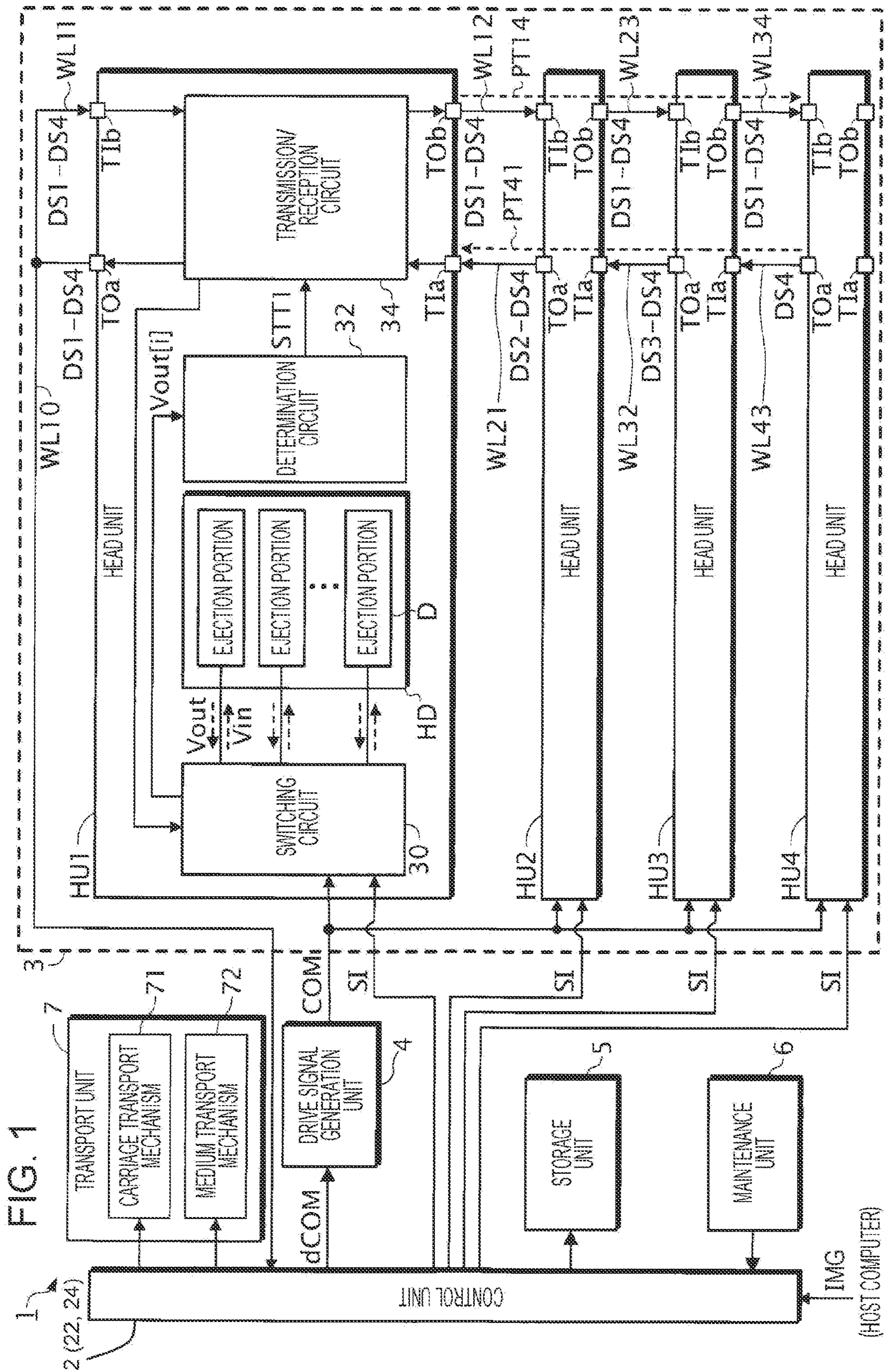

FIG. 2

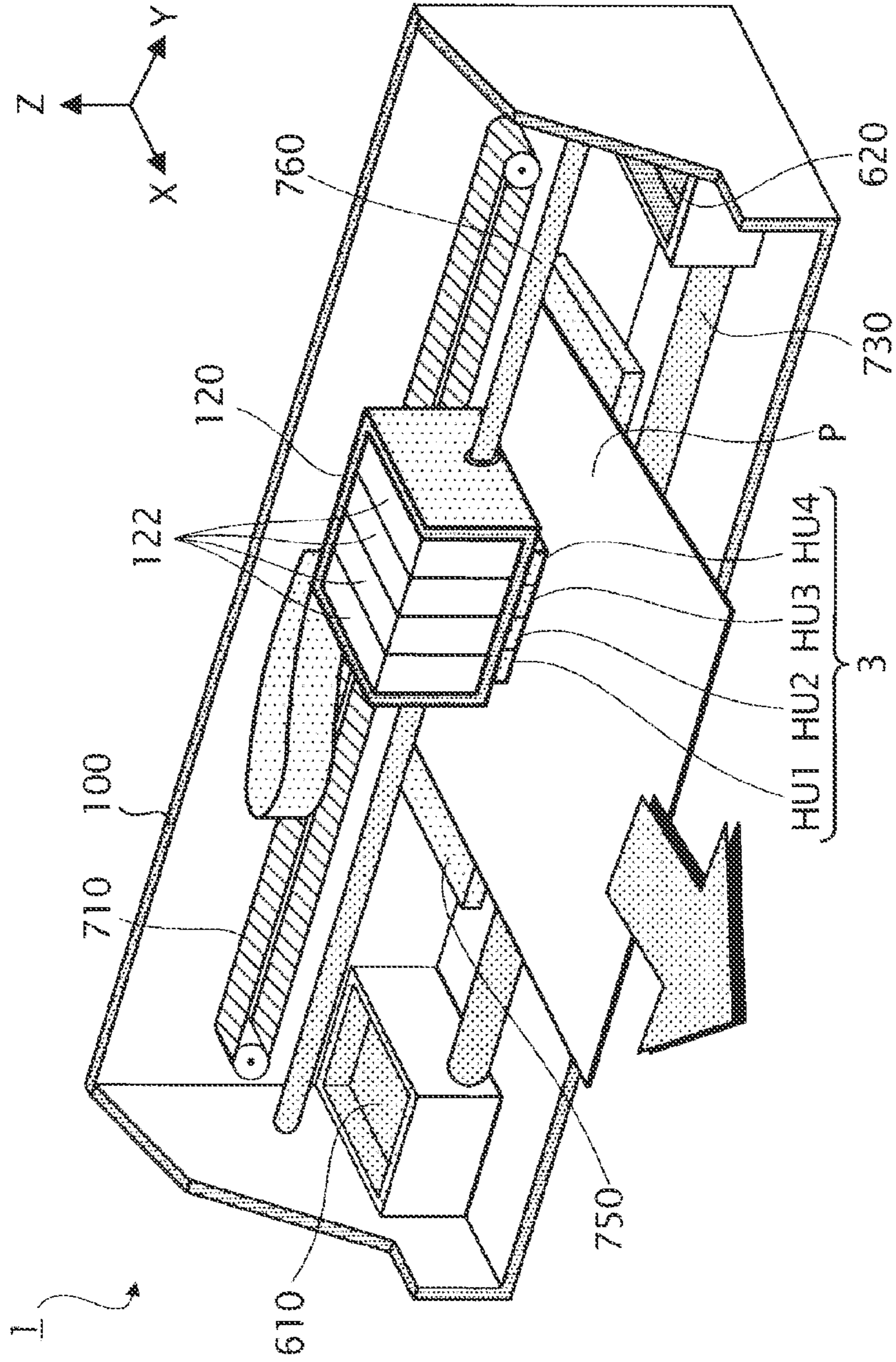

FIG. 3

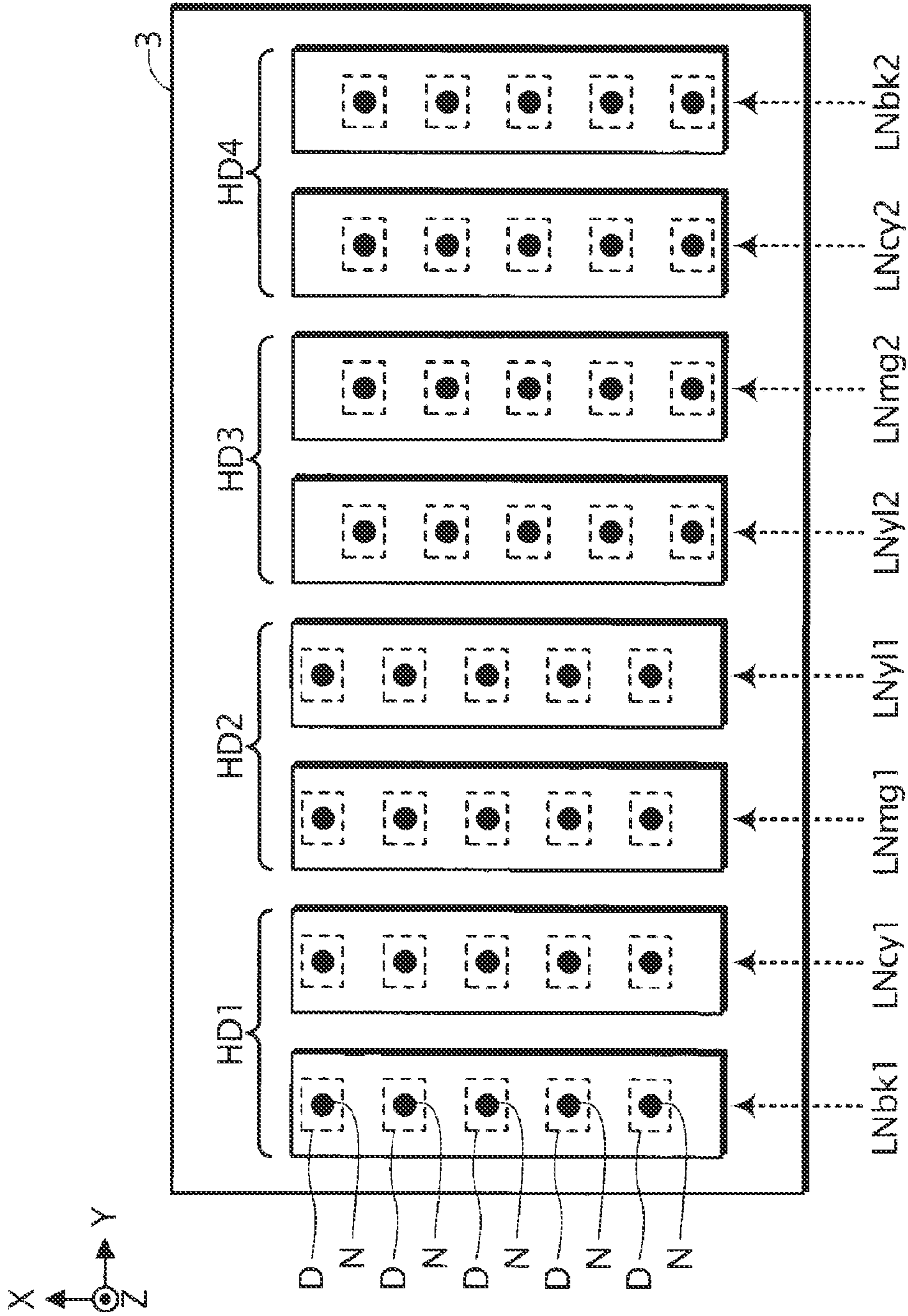

FIG. 4

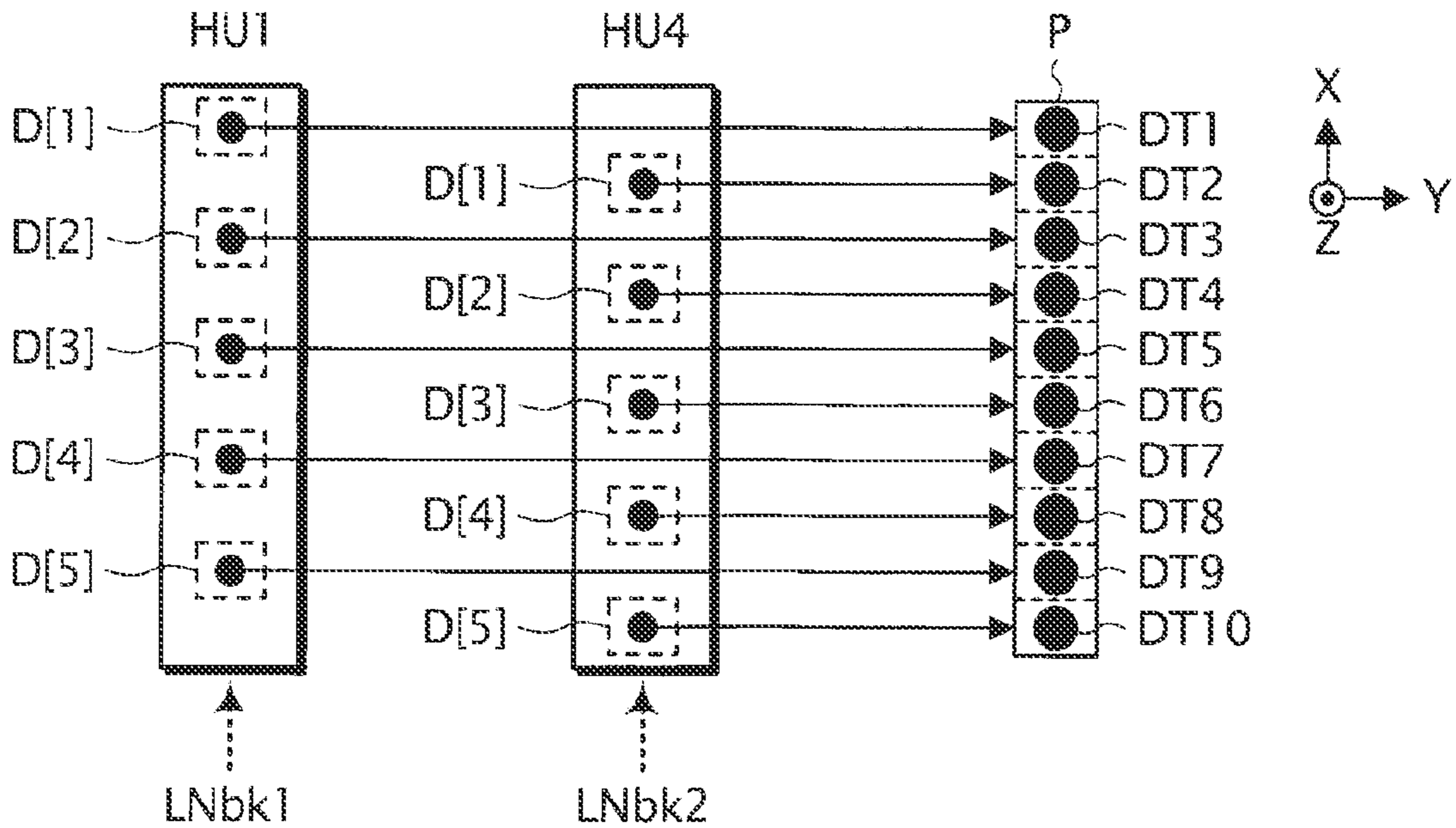
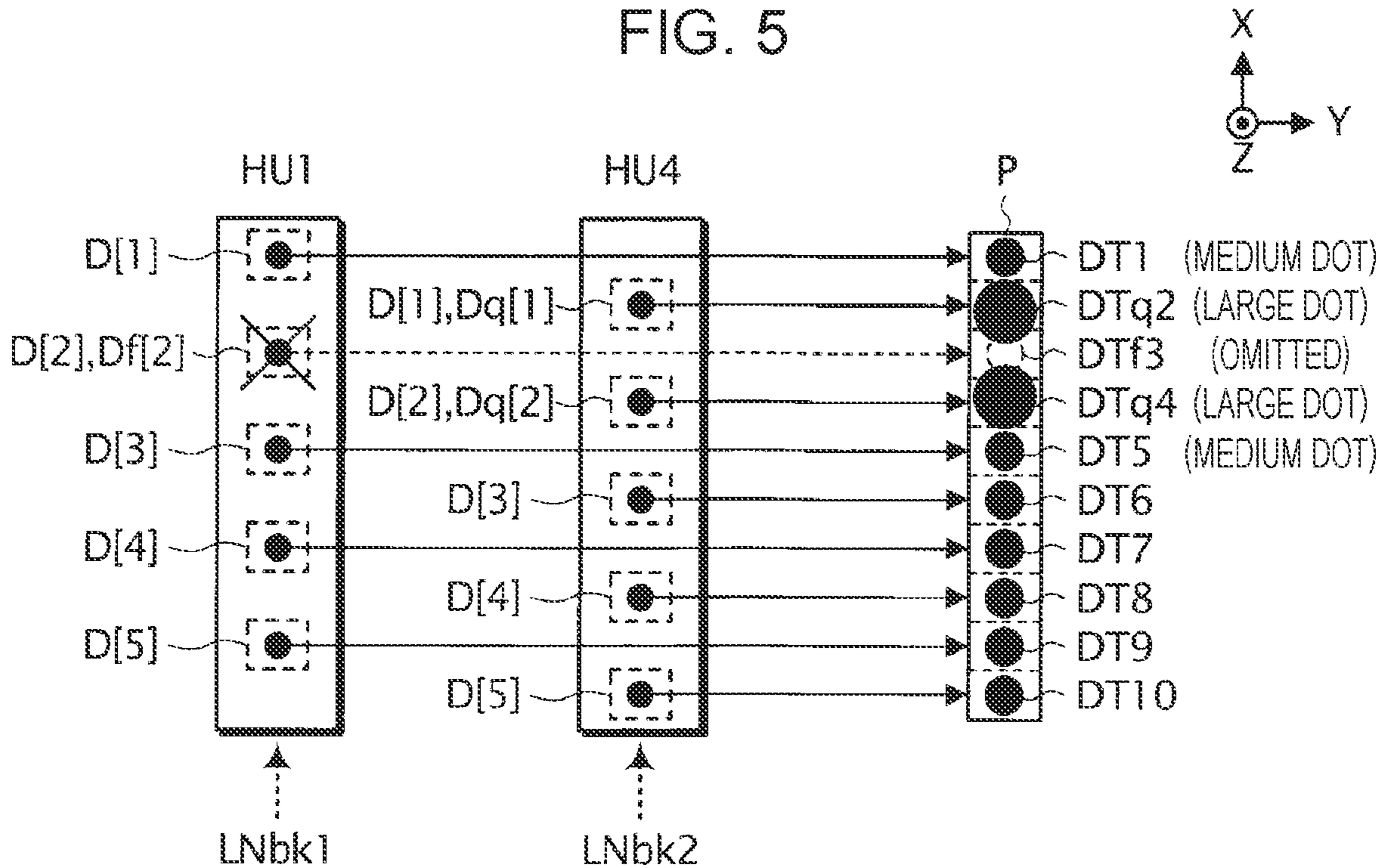

FIG. 5



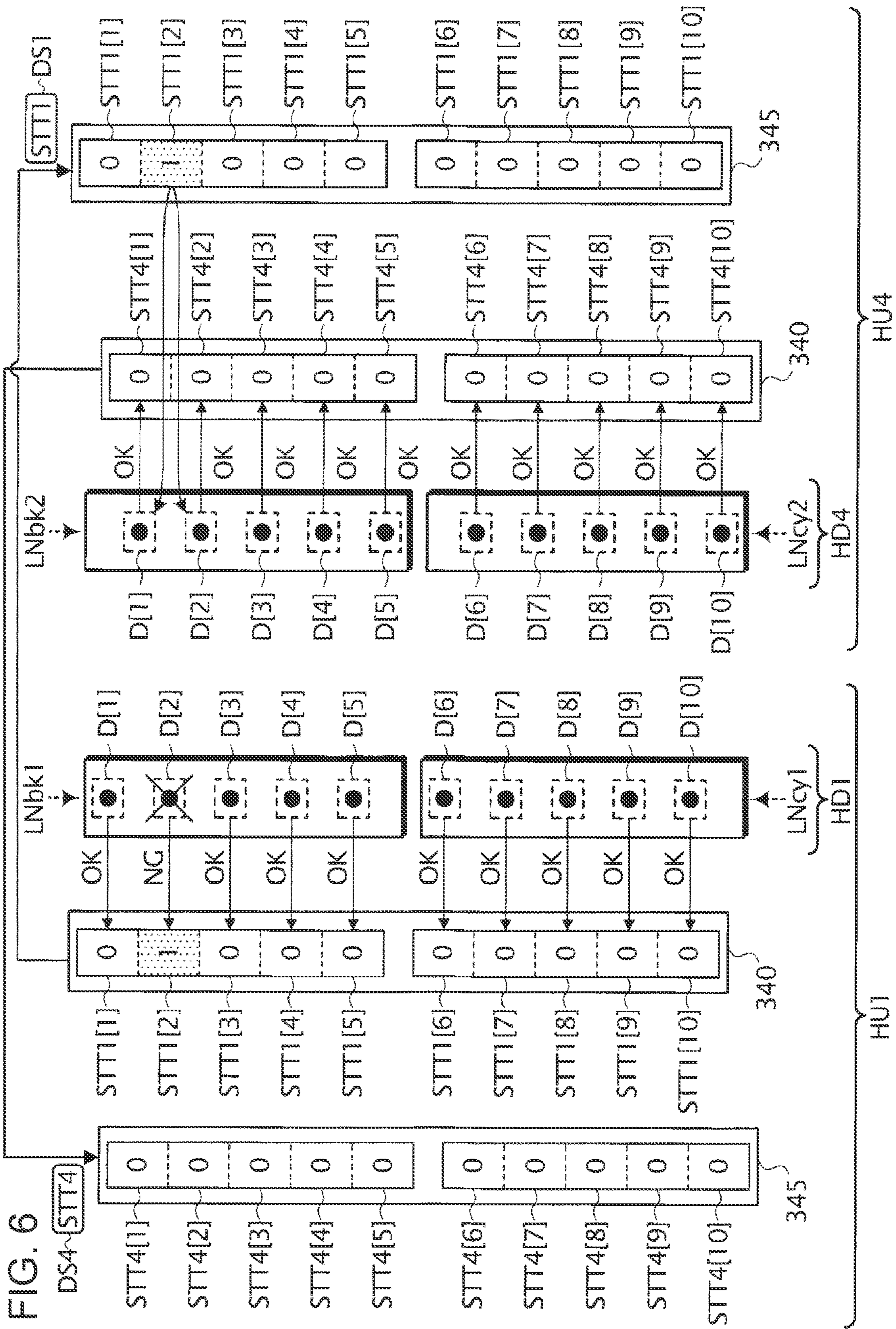

FIG. 7

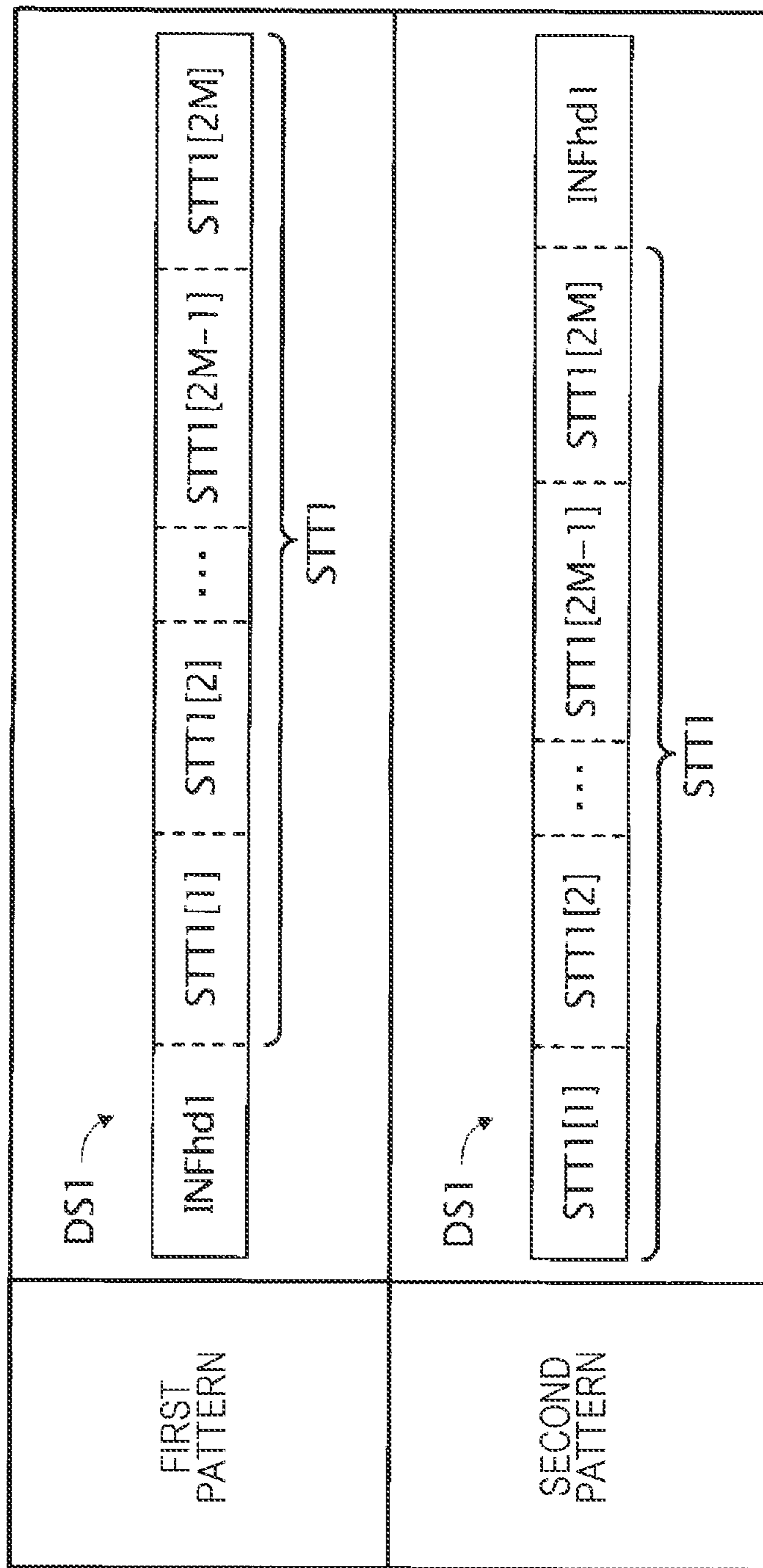

FIG. 9

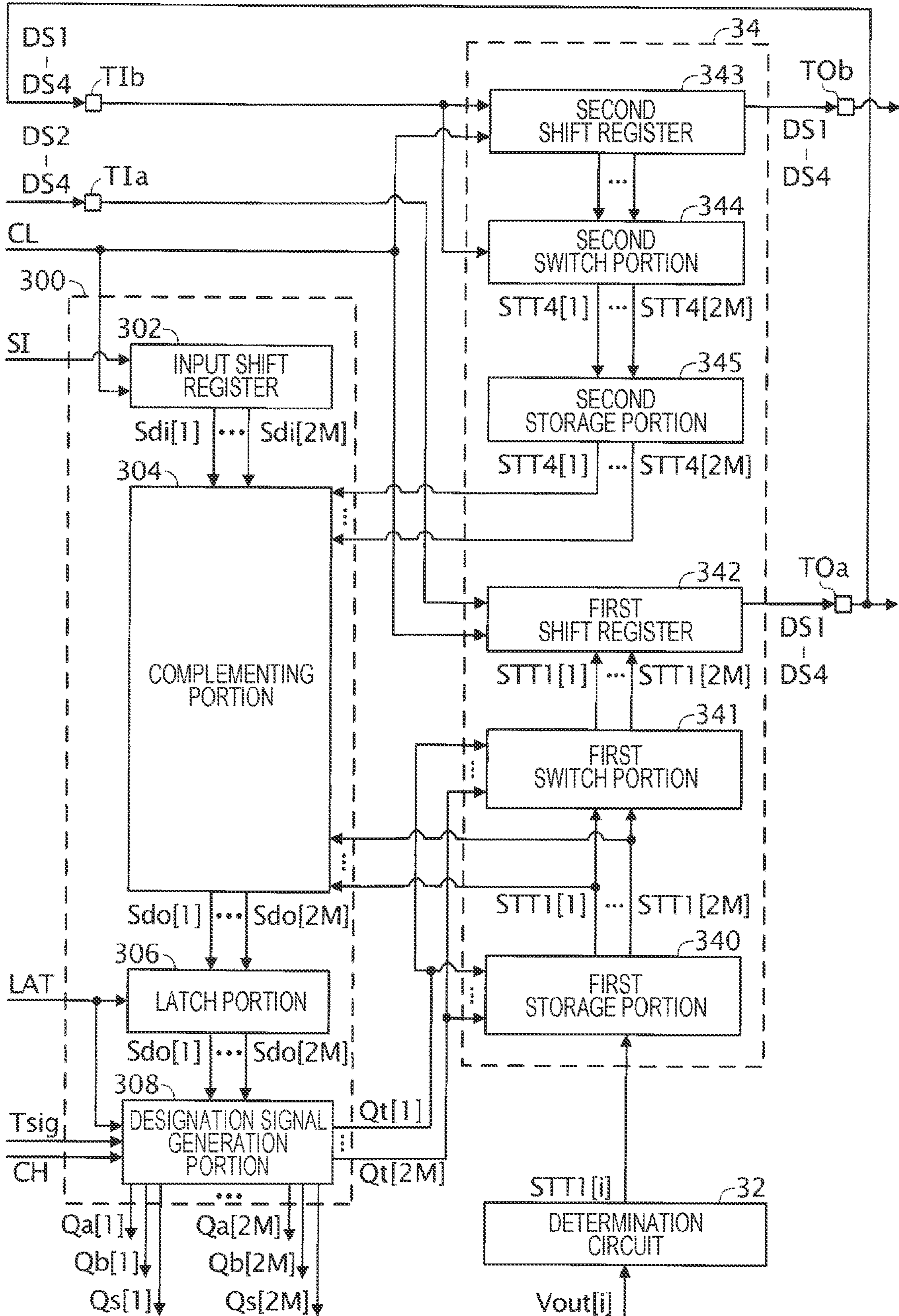

FIG. 11

Sdo[i] (b1,b2,b3)	DESIGNATED CONTENT FOR Sdo[i]	Qa[i]			Qb[i]			Qs[i]				
		Tu1	Tu2	TSS1	TSS2	TSS3	TSS1	TSS2	TSS3	TSS1	TSS2	TSS3
(1, 1, 0)	LARGE DOT	H	H	L	L	L	L	L	L	L	L	L
(1, 0, 0)	MEDIUM DOT	H	L	L	L	L	L	L	L	L	L	L
(0, 1, 0)	SMALL DOT	L	H	L	L	L	L	L	L	L	L	L
(0, 0, 0)	NON-RECORDING	L	L	L	L	L	L	L	L	L	L	L
(1, 1, 1)	DETERMINATION TARGET	L	L	H	L	H	L	H	L	L	H	L

FIG. 12

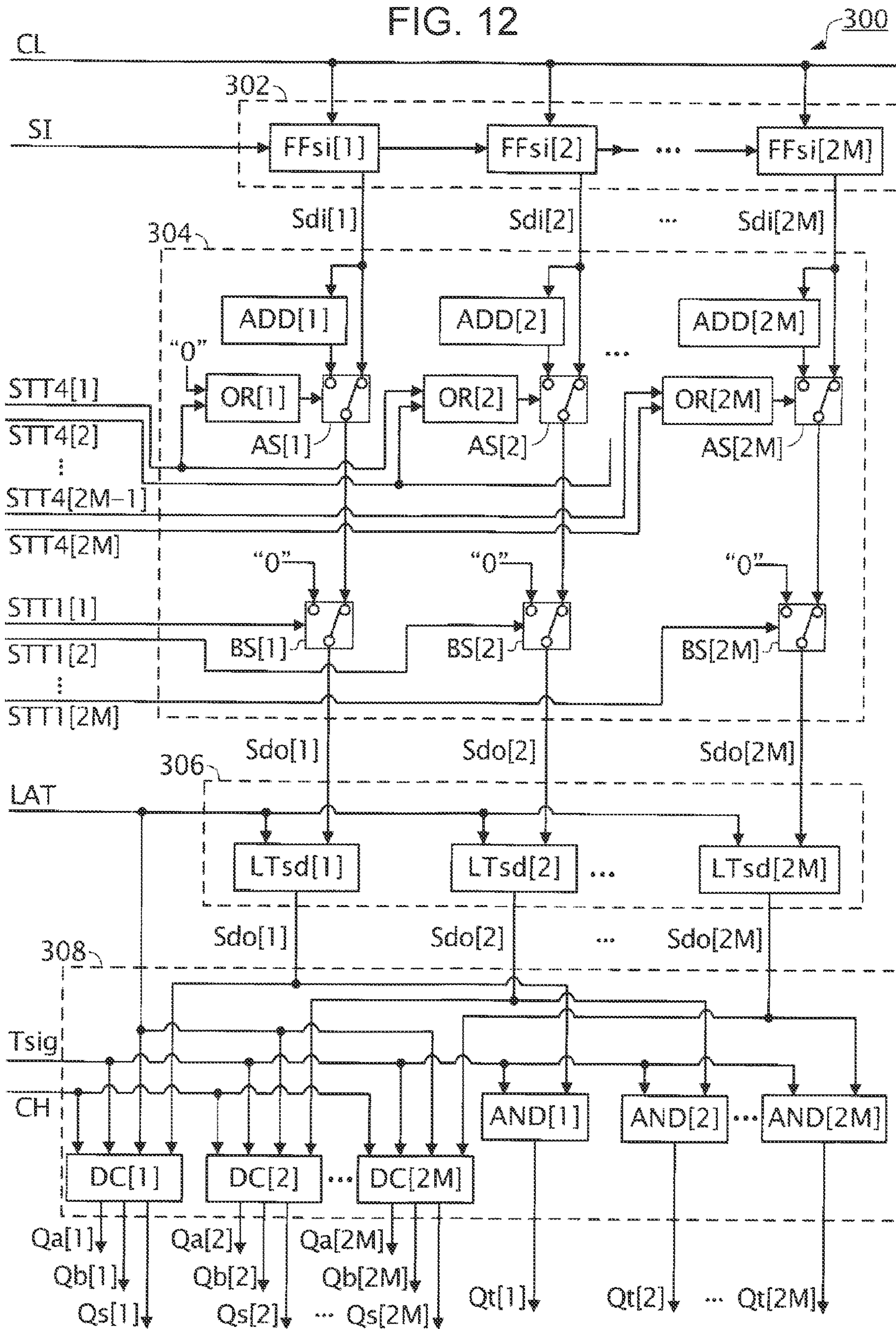

FIG. 13

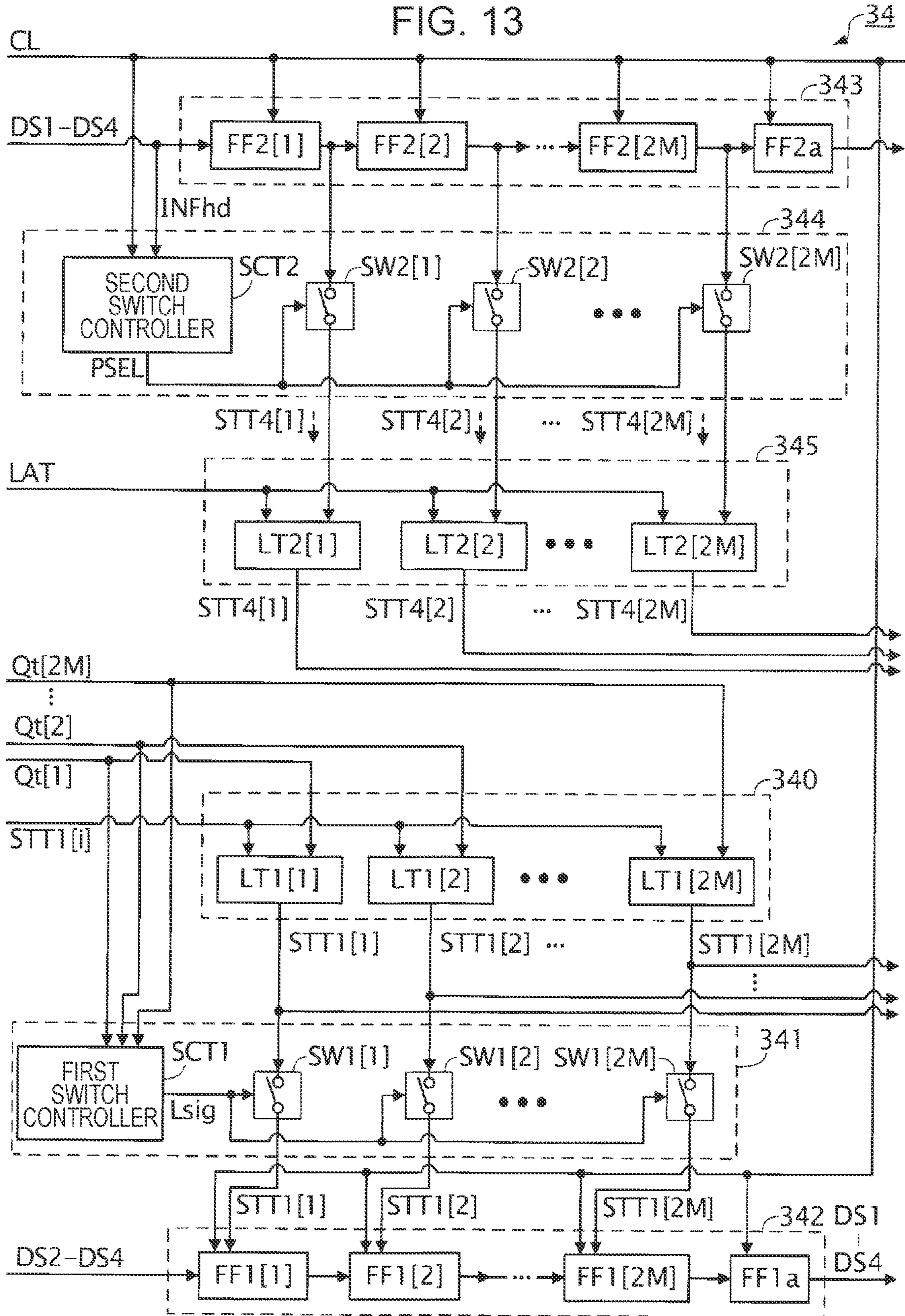

FIG. 14

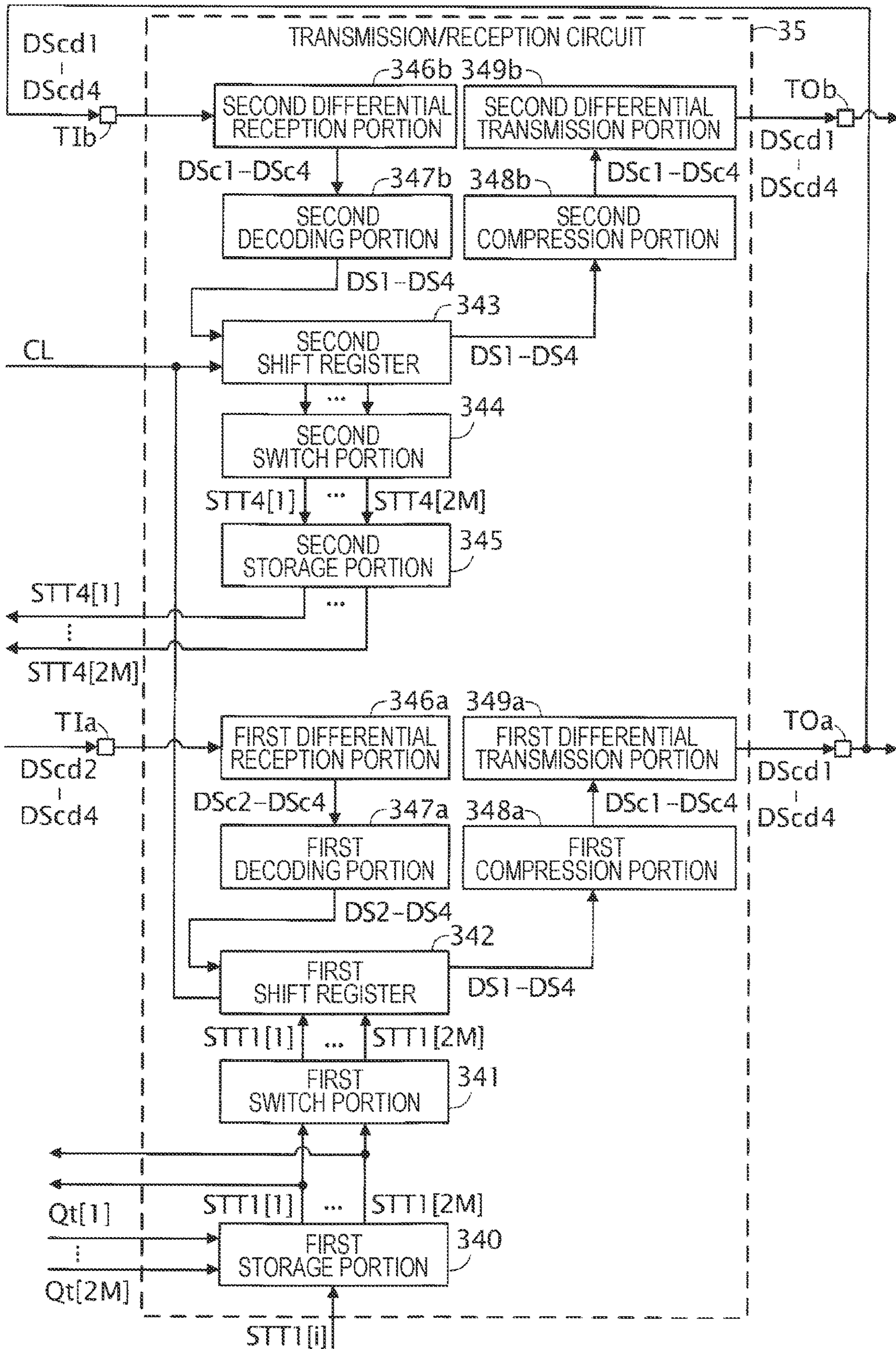

FIG. 15

STT		NOZZLE STATE	COPING
STTa	STTb		
0	0	NORMAL	NORMAL PRINTING PROCESS
1	0	ABNORMAL	COMPLEMENTARY PRINTING PROCESS, NOZZLE MAINTENANCE PROCESS
1	1	FAILURE	COMPLEMENTARY PRINTING PROCESS

FIG. 16

STT					NOZZLE STATE	COPING
STTa	STTb	STTc	STTd	STTe		
0	0	0	0	0	NORMAL	NORMAL PRINTING PROCESS
1	0	1	0	0	BUBBLE	COMPLEMENTARY PRINTING PROCESS, NOZZLE MAINTENANCE PROCESS
1	0	0	1	0	THICKENING	COMPLEMENTARY PRINTING PROCESS, NOZZLE MAINTENANCE PROCESS
1	0	0	0	1	ADHESION	COMPLEMENTARY PRINTING PROCESS, NOZZLE MAINTENANCE PROCESS
1	1	0	0	0	FAILURE	COMPLEMENTARY PRINTING PROCESS

FIG. 17

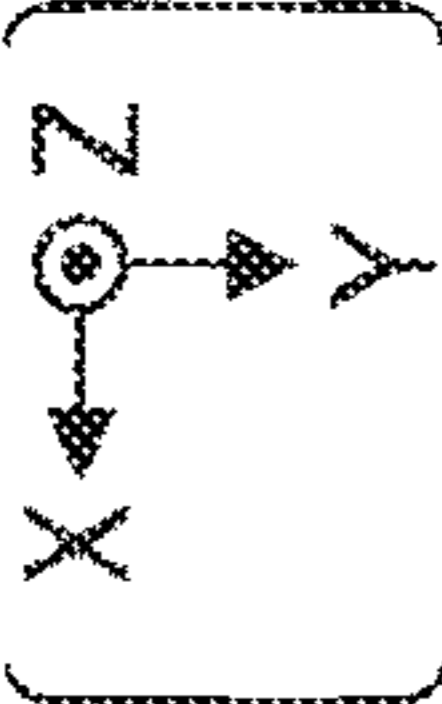
ARRANGEMENT INFORMATION	NOZZLE ARRANGEMENT 																											
01 (ARRANGED IN ONE ROW)	1	2	3	4	5	6	7	8	9	10	11	12	13	14														
02 (ARRANGED IN ONE ROW)	14	13	12	11	10	9	8	7	6	5	4	3	2	1														
03 (ARRANGED IN TWO ROWS)	1	2	3	4	5	6	7	8	9	10	11	12	13	14	15	16	17	18	19	20	21	22	23	24	25	26	27	28
04 (ARRANGED IN TWO ROWS)	1	3	5	7	9	11	13	15	17	19	21	23	25	27	2	4	6	8	10	12	14	16	18	20	22	24	26	28
05 (ARRANGED IN ZIGZAG)	1	2	3	4	5	6	7	8	9	10	11	12	13	14	15	16	17	18	19	20	21	22	23	24	25	26	27	
06 (ARRANGED IN ZIGZAG)	1	3	5	7	9	11	13	15	17	19	21	23	25	27	2	4	6	8	10	12	14	16	18	20	22	24	26	

1**HEAD UNIT CONTROL DEVICE, HEAD UNIT, AND LIQUID EJECTION DEVICE**

The present application is based on, and claims priority from JP Application Serial Number 2019-235447, filed Dec. 26, 2019, the disclosure of which is hereby incorporated by reference herein in its entirety.

BACKGROUND**1. Technical Field**

The present disclosure relates to a head unit control device, a head unit, and a liquid ejection device.

2. Related Art

JP-A-2016-049691 discloses a liquid ejection device such as an ink jet printer that ejects a liquid such as ink from each of a plurality of ejection portions included in a head unit to form an image on a medium, and has a determination section that executes a determination process for determining an ejection state of the ink from each ejection portion. In this type of liquid ejection device, for example, whenever a determination process for one ejection portion among a plurality of ejection portions is finished, a determination portion outputs determination information indicating a determination result for the ejection portion to a control portion controlling a head unit and the like.

Meanwhile, in a case where a transmission process of transmitting determination information corresponding to an ejection portion is executed whenever a determination process for one of a plurality of ejection portions is finished, there is concern that the time required for the transmission process may increase as the number of ejection portions increases.

SUMMARY

In order to solve the above problem, according to an aspect of the present disclosure, there is provided a head unit control device controlling a head unit including a plurality of ejection portions that includes a first ejection portion and a second ejection portion and a determination portion that determines a liquid ejection state of the first ejection portion and determines a liquid ejection state of the second ejection portion, the head unit control device including a reception portion that receives, as one data set, determination result information including first determination information indicating a determination result of the liquid ejection state of the first ejection portion from the determination portion and second determination information indicating a determination result of the liquid ejection state of the second ejection portion from the determination portion, and ejection portion information including information indicating the number of the plurality of ejection portions included in the head unit, from the head unit; and an ejection control portion that controls the plurality of ejection portions based on the one data set received by the reception portion.

BRIEF DESCRIPTION OF THE DRAWINGS

FIG. 1 is a block diagram illustrating an example of a configuration of an ink jet printer including a control unit according to an embodiment of the present disclosure.

FIG. 2 is a perspective view illustrating an example of a schematic internal structure of the ink jet printer.

2

FIG. 3 is a plan view illustrating an example of the arrangement of nozzles in the head module.

FIG. 4 is an explanatory diagram for describing a normal printing process.

FIG. 5 is an explanatory diagram for describing a complementary printing process.

FIG. 6 is an explanatory diagram for describing transmission of determination information.

FIG. 7 is a diagram illustrating an example of a data set including the determination information.

FIG. 8 is a block diagram illustrating a configuration of a head unit.

FIG. 9 is a block diagram illustrating configurations of a coupling state designation circuit and a transmission/reception circuit.

FIG. 10 is a timing chart illustrating an example of the operation of the ink jet printer.

FIG. 11 is an explanatory diagram for describing generation of a coupling state designation signal in a designation signal generation portion.

FIG. 12 is a diagram illustrating an example of a circuit configuration of a coupling state designation circuit.

FIG. 13 is a diagram illustrating an example of a circuit configuration of a transmission/reception circuit.

FIG. 14 is a block diagram illustrating a configuration of a transmission/reception circuit according to Modification Example 2.

FIG. 15 is an explanatory diagram for describing an example of determination information according to Modification Example 3.

FIG. 16 is an explanatory diagram for describing another example of determination information according to Modification Example 3.

FIG. 17 is an explanatory diagram for describing an arrangement of nozzles according to Modification Example 4.

FIG. 18 is a block diagram illustrating an example of a configuration of an ink jet printer according to Modification Example 5.

DESCRIPTION OF EXEMPLARY EMBODIMENTS

Hereinafter, embodiments of the present disclosure will be described with reference to the drawings. However, in each drawing, the size and scale of each constituent are appropriately different from the actual ones. The embodiment described below is a preferred specific example of the present disclosure, so that various technically preferable limitations are attached thereto, but the scope of the present disclosure is not limited to these forms unless it is particularly stated that the present disclosure is limited in the following description.

1. EMBODIMENT

First, a configuration of an ink jet printer 1 according to the present embodiment will be described with reference to FIGS. 1 and 2.

FIG. 1 is a block diagram illustrating an example of a configuration of the ink jet printer 1 including a control unit 2 according to an embodiment of the present disclosure. In the present embodiment, a liquid ejection device will be described by exemplifying the ink jet printer 1 that ejects ink to form an image on recording paper P. In the present embodiment, the control unit 2 is an example of a "head unit

control device”, the ink is an example of a “liquid”, and the recording paper P is an example of a “medium”.

Printing data IMG indicating an image to be formed on the recording paper P by the ink jet printer 1 is supplied to the ink jet printer 1 from a host computer such as a personal computer or a digital camera. For example, the ink jet printer 1 executes a printing process of forming an image indicated by the printing data IMG supplied from the host computer on the recording paper P. The printing data IMG is an example of “image information”. The ink jet printer 1 may have any one of a copy function, a scanner function, a facsimile transmission function, and a facsimile reception function in addition to the printing function. In other words, the ink jet printer 1 may correspond to a so-called “multifunction peripheral”.

In the example illustrated in FIG. 1, the ink jet printer 1 includes a control unit 2, a head module 3 including head units HU1, HU2, HU3, and HU4, a drive signal generation unit 4, a storage unit 5, a maintenance unit 6, and a transport unit 7. Hereinafter, the head units HU1, HU2, HU3, and HU4 will be referred to as a head unit HU when the head units are not required to be differentiated from each other in some cases.

In the present embodiment, as illustrated in FIG. 1, a case where the head module 3 includes four head units HU is assumed as an example. Hereinafter, among the four head units HU, the head unit HU1 will be described, but the description also applies to the other head units HU. For example, as illustrated in FIG. 1, the head unit HU1 includes a switching circuit 30, a recording head HD including a plurality of ejection portions D that eject ink, a determination circuit 32, and a transmission/reception circuit 34. Although functional blocks of the other head units HU are not illustrated, each of the head units HU2, HU3, and HU4 also includes the switching circuit 30, the recording head HD, the determination circuit 32, and the transmission/reception circuit 34, in the same manner as the head unit HU1. Details of the switching circuit 30, the recording head HD, the determination circuit 32, and the transmission/reception circuit 34 will be described later.

The control unit 2 is, for example, a computer such as a central processing unit (CPU) that controls each constituent of the ink jet printer 1. The control unit 2 may have one or more processors. For example, the control unit 2 functions as a printing control portion 22 and an information reception portion 24 by executing a control program stored in the storage unit 5. All or some of the elements realized by the control unit 2 executing the control program may be realized by hardware such as an electronic circuit including a field programmable gate array (FPGA) or an application specific integrated circuit (ASIC). Alternatively, all or some of the functions of the control unit 2 may be realized by software and hardware in cooperation.

The printing control portion 22 generates signals for controlling an operation of each constituent of the ink jet printer 1, such as a printing signal SI and a waveform designation signal dCOM. Here, the waveform designation signal dCOM is a digital signal for defining a waveform of an analog drive signal COM for driving the ejection portion D. For example, the waveform designation signal dCOM is supplied from the printing control portion 22 to the drive signal generation unit 4. The printing signal SI is a digital signal for designating the type of operation of the ejection portion D. Specifically, the printing signal SI is a signal for designating the type of operation of the ejection portion D by designating whether or not the drive signal COM is supplied to the ejection portion D. The printing signal SI defines an

ejection amount of ink ejected from each ejection portion D by designating whether or not the drive signal COM is supplied to the ejection portion D.

The information reception portion 24 receives, for example, the data set DS transmitted from the head unit HU to the control unit 2. The data set DS received by the information reception portion 24 may be supplied to, for example, the printing control portion 22 or the like, or may be stored in the storage unit 5. The data set DS will be described later. The printing control portion 22 is an example of an “ejection control portion”, and the information reception portion 24 is an example of a “reception portion”.

The drive signal generation unit 4 includes a DA conversion circuit and generates the drive signal COM having a waveform defined by the waveform designation signal dCOM. In the present embodiment, it is assumed that the drive signal COM includes a drive signal COMa and a drive signal COMb.

The storage unit 5 is configured to include a volatile memory such as a random access memory (RAM), and a nonvolatile memory such as a read only memory (ROM), an electrically erasable programmable read-only memory (EEPROM), or a programmable ROM (PROM). For example, the storage unit 5 stores various kinds of information such as the printing data IMG supplied from the host computer and the control program for the ink jet printer 1.

When an ejection state of ink in the ejection portion D becomes abnormal, the maintenance unit 6 performs a maintenance process for recovering the ejection state of the ink in the ejection portion D to a normal state. The ejection state includes a state in which ink is not ejected from the ejection portion D. The ejection state of the ink in the ejection portion D is determined by the determination circuit 32 which will be described later. In the following description, the ejection of ink ejected from the ejection portion D becomes abnormal, that is, a state in which the ejection portion D cannot eject the ink accurately may be referred to as abnormal ejection. For example, the abnormal ejection includes a state in which ink cannot be ejected from the ejection portion D, a state in which the ejection portion D ejects ink in an amount that is different from an ejection amount of ink defined by the drive signal COM, and a state in which the ejection portion D ejects ink at a speed that is different from an ink ejection speed defined by the drive signal COM.

The transport unit 7 has a carriage transport mechanism 71 reciprocating a carriage 120 illustrated in FIG. 2 described later, and a medium transport mechanism 72 transporting the recording paper P, and changes a relative position of the recording paper P with respect to the head module 3. An operation and the like of the transport unit 7 will be described with reference to FIG. 2.

As described above, each head unit HU included in the head module 3 has the switching circuit 30, the recording head HD, the determination circuit 32, and the transmission/reception circuit 34. The recording head HD includes $2 \times M$ ejection portions D. Here, the value M is “M 1”, M being a natural number. In the following description, “ $2 \times M$ ” may be simply referred to as “2M”. In the following description, among the 2M ejection portions D provided in the recording head HD, the i-th ejection portion D may be referred to as an ejection portion D[i]. Here, the variable i is “ $1 \leq i \leq 2M$ ”, M being a natural number. In the following description, when a constituent element of or a signal for the ink jet printer 1 corresponds to the ejection portion D[i] among the 2M ejection portions D, the reference numeral for representing

the constituent element or the signal may be added with the subscript [i]. The 2M ejection portions D are examples of “a plurality of ejection portions”. One of two ejection portions D among the 2M ejection portions D is an example of a “first ejection portion”, and the other of the two ejection portions D is an example of a “second ejection portion”.

The switching circuit 30 switches whether or not to supply the drive signal COM output from the drive signal generation unit 4 to the ejection portion D[i] based on the printing signal SI. In the following description, among the drive signals COM, the drive signal COM supplied to the ejection portion D[i] may be referred to as a supply drive signal Vin[i]. The switching circuit 30 switches whether or not to supply a detection signal Vout[i] indicating a potential of an upper electrode Zu[i] of a piezoelectric element PZ[i] included in the ejection portion D[i] to the determination circuit 32 based on the printing signal SI. The piezoelectric element PZ[i] and the upper electrode Zu[i] will be described later with reference to FIG. 8.

The determination circuit 32 generates determination information STT1[i] indicating a determination result of the ink ejection state in the ejection portion D[i] based on the detection signal Vout[i]. Specifically, the determination circuit 32 generates a remaining vibration signal based on the detection signal Vout[i]. The determination circuit 32 compares feature amounts such as a cycle and an amplitude of the remaining vibration signal based on the detection signal Vout[i] with reference feature amounts when an ejection state is normal, so as to determine an ink ejection state in the ejection portion D[i], and generates the determination information STT1[i] indicating the determination result. Hereinafter, the ejection portion D that is a target of an ejection state determined by the determination circuit 32 may be referred to as the determination target ejection portion D. The determination circuit 32 is an example of a “determination portion”.

Here, the remaining vibration signal based on the detection signal Vout[i] indicates a waveform of remaining vibration that is vibration remaining in the ejection portion D[i] after the ejection portion D[i] is driven by the supply drive signal Vin[i]. The number at the end of the reference sign of the determination information STT1 corresponds to the number at the end of the reference sign of the head unit HU1. Therefore, for example, the determination information STT indicating a determination result of an ink ejection state in the ejection portion D included in the head unit HU4 may also be referred to as determination information STT4. The determination information STT is an example of “determination result information”. The determination information STT for the ejection portion D corresponding to the “first ejection portion” among the 2M ejection portions D is an example of “first determination information”, and the determination information STT for the ejection portion D corresponding to the “second ejection portion” is an example of “second determination information”.

In the present embodiment, a method of using the remaining vibration signal is assumed as a method of determining an ink ejection state in the ejection portion D. However, the method of determining the ink ejection state in the ejection portion D is not limited to the method using the remaining vibration signal. For example, as a method of determining the ejection state of the ink in the ejection portion D, a method of detecting a temperature decrease occurring in the ejection portion D when the ink is ejected normally may be adopted. In this type of determination method, when a change point at which a temperature decrease rate changes after a certain time from the time at which a detected

temperature reaches the maximum temperature appears, the ink ejection state is determined as being normal, and, when the change point does not appear, the ink ejection state is determined as being abnormal. For example, as the method of determining the ink ejection state in the ejection portion D, there may be the use of a method of ejecting charged ink from the ejection portion D toward a detection plate used to detect the ink ejection state and detecting a current change when the ink collides with the detection plate. For example, as the method of determining the ink ejection state in the ejection portion D, there may be the use of a method of ejecting charged ink from the ejection portion D toward an ink reception portion, and detecting the presence or absence of an induced current generated in a conductor portion when the ink passes a side part of the conductor portion disposed between the ejection portion D and the ink reception portion.

The transmission/reception circuit 34 combines, for example, a data set DS1 including the determination information STT1 output from the determination circuit 32 with data sets DS2, DS3, and DS4 supplied to a terminal T1a of the head unit HU1, and outputs the combined result to a terminal TOa of the head unit HU1. The data set DS2 is a data set DS including the determination information STT2 for the head unit HU2, the data set DS3 is a data set DS including the determination information STT3 for the head unit HU3, and the data set DS4 is a data set DS including the determination information STT4 for the head unit HU4.

The transmission/reception circuit 34 outputs, for example, the data sets DS1, DS2, DS3, and DS4 supplied to the terminal T1b of the head unit HU1 to the terminal TOb of the head unit HU1. The transmission/reception circuit 34 is an example of a “transmission portion”.

In the example illustrated in FIG. 1, the terminal T1a of the head unit HU1 is electrically coupled to the terminal TOa of the head unit HU2. The terminal TOa of the head unit HU1 is electrically coupled to the terminal T1b of the head unit HU1 and the control unit 2. The terminal TOb of the head unit HU1 is electrically coupled to the terminal T1b of the head unit HU2.

The terminal T1a of the head unit HU2 is electrically coupled to the terminal TOa of the head unit HU3, and the terminal TOb of the head unit HU2 is electrically coupled to the terminal T1b of the head unit HU3. The terminal T1a of the head unit HU3 is electrically coupled to the terminal TOa of the head unit HU4, and the terminal TOb of the head unit HU3 is electrically coupled to the terminal T1b of the head unit HU4. In the example illustrated in FIG. 1, the terminal T1a and the terminal TOb of the head unit HU4 are not coupled to the other head units HU. Next, a flow of each data set DS when the head units HU1, HU2, HU3, and HU4 are coupled as illustrated in FIG. 1 will be described.

For example, in the head unit HU4, the transmission/reception circuit 34 transmits the data set DS4 including the determination information STT4 output from the determination circuit 32 to the terminal T1a of the head unit HU3. In the head unit HU3, the transmission/reception circuit 34 transmits the data set DS3 including the determination information STT3 output from the determination circuit 32 and the data set DS4 supplied to the terminal T1a, to the terminal T1a of the head unit HU2 in an order of the data sets DS3 and DS4.

In the head unit HU2, the transmission/reception circuit 34 transmits the data set DS2 including the determination information STT2 output from the determination circuit 32 and the data sets DS3 and DS4 supplied to the terminal T1a, to the terminal T1a of the head unit HU1 in an order of the data sets DS2, DS3, and DS4.

In the head unit HU1, the transmission/reception circuit 34 transmits the data set DS1 including the determination information STT1 output from the determination circuit 32 and the data sets DS2, DS3, and DS4 supplied to the terminal TIa, to the control unit 2 and the terminal TIb in an order of the data sets DS1, DS2, DS3, and DS4.

In the head unit HU1, the transmission/reception circuit 34 transmits the data sets DS1, DS2, DS3, and DS4 supplied to the terminal TIb, to the terminal TIb of the head unit HU2 in the order of the data sets being supplied to the terminal TIb. Similarly, in the head unit HU2, the transmission/reception circuit 34 transmits the data sets DS1, DS2, DS3, and DS4 supplied to the terminal TIb, to the terminal TIb of the head unit HU3 in the order of the data sets being supplied to the terminal TIb. In the head unit HU3, the transmission/reception circuit 34 transmits the data sets DS1, DS2, DS3, and DS4 supplied to the terminal TIb, to the terminal TIb of the head unit HU4 in the order of the data sets being supplied to the terminal TIb.

Consequently, the data set DS for each head unit HU is supplied to the other head units HU and the control unit 2. In other words, the determination information STT for each head unit HU is supplied to the other head units HU and the control unit 2.

FIG. 2 is a perspective view illustrating an example of a schematic internal structure of the ink jet printer 1. As illustrated in FIG. 2, in the present embodiment, a case where the ink jet printer 1 is a serial printer is assumed as an example. Specifically, when a printing process is executed, the ink jet printer 1 ejects ink from the ejection portions D while transporting the recording paper P in a sub-scanning direction and reciprocating the head module 3 in a main scanning direction intersecting the sub-scanning direction, and thus forms dots corresponding to the printing data IMG on the recording paper P.

Hereinafter, for convenience of description, the description will be made by using an X axis, a Y axis, and a Z axis which are orthogonal to each other illustrated in FIG. 2 as appropriate. The direction indicated by the arrow of the X axis is referred to as a +X direction, and the direction opposite to the +X direction is referred to as a -X direction. Similarly, the direction indicated by the arrow of the Y axis is referred to as a +Y direction, and the direction opposite to the +Y direction is referred to as a -Y direction. The direction indicated by the arrow of the Z axis is referred to as a +Z direction, and the direction opposite to the +Z direction is referred to as -Z direction. In the present embodiment, the +X direction is set to the sub-scanning direction, and the +Y direction and the -Y direction are set to the main scanning directions.

As illustrated in FIG. 2, the ink jet printer 1 includes a casing 100 and a carriage 120 that can be reciprocated in the casing 100 in the +Y direction and the -Y direction and that has the head module 3 mounted thereon. As described with reference to FIG. 1, the ink jet printer 1 includes the maintenance unit 6 and the transport unit 7.

When the printing process is performed, the transport unit 7 reciprocates the carriage 120 in the +Y direction and the -Y direction, and transports the recording paper P in the +X direction, and thus changes a relative position of the recording paper P with respect to the head module 3. Consequently, the transport unit 7 enables the ink to land onto the entire recording paper P. For example, the transport unit 7 includes a carriage guide shaft 760 that reciprocatively supports the carriage 120 in the +Y direction and the -Y direction, and a timing belt 710 that is fixed to the carriage 120 and is driven by the carriage transport mechanism 71. Consequently, the

transport unit 7 can reciprocate the head module 3 together with the carriage 120 in the +Y direction and the -Y direction along the carriage guide shaft 760. The transport unit 7 has a platen 750 that is provided in the -Z direction with respect to the carriage 120, and a transport roller 730 that is rotated in response to driving of the medium transport mechanism 72 to transport the recording paper P on the platen 750 in the +X direction.

The maintenance unit 6 includes a cap 610 that covers each head unit HU such that nozzles N of the ejection portions D are sealed, and a discharged ink reception portion 620 that receives discharged ink when the ink in the ejection portion D is discharged. The maintenance unit 6 has a wiper that wipes off a foreign substance such as paper powder adhering to the vicinity of the nozzle N of the ejection portion D, and a tube pump that sucks ink, bubbles, and the like in the ejection portion D, although not particularly illustrated. The nozzle N will be described later in FIG. 3. In the present embodiment, an aspect in which the cap 610 is attached to the casing 100 is exemplified, but the present disclosure is not limited to such an aspect, and the cap 610 may be attached to the carriage 120.

In the present embodiment, a case is assumed in which the carriage 120 stores four ink cartridges 122 that respectively correspond to ink with four colors such as cyan, magenta, yellow, and black. FIG. 2 illustrates only an example, and the ink cartridge 122 may be provided outside the carriage 120. Each ejection portion D is supplied with ink from any one of the four ink cartridges 122. Each of the ejection portions D may be filled with the ink supplied from the ink cartridge 122 and may eject the ink filling the inside thereof from the nozzle N. The ink cartridge 122 may be provided outside the carriage 120.

Here, a description will be made of an outline of an operation of the printing control portion 22 when the printing process is executed. When the printing process is executed, first, the printing control portion 22 stores the printing data IMG supplied from the host computer into the storage unit 5. Next, the printing control portion 22 generates a signal such as the printing signal SI for controlling the head unit HU, and a signal such as the waveform designation signal dCOM for controlling the drive signal generation unit 4, and a signal for controlling the transport unit 7 based on various pieces of data such as the printing data IMG stored in the storage unit 5. The printing control portion 22 controls the transport unit 7 to change a relative position of the recording paper P with respect to the head module 3, and also controls the drive signal generation unit 4 and the switching circuit 30 such that the ejection portion D is driven, based on various signals such as the printing signal SI or various pieces of data stored in the storage unit 5. Therefore, the printing control portion 22 controls each constituent of the ink jet printer 1 to execute a printing process of forming an image corresponding to the printing data IMG on the recording paper P by adjusting the presence or absence of ink ejection from the ejection portion D, an ink ejection amount, an ink ejection timing, and the like.

A configuration of the ink jet printer 1 is not limited to the examples illustrated in FIGS. 1 and 2. For example, the number of head units HU may be two or three. Alternatively, the number of head units HU may be five or more. The ink jet printer 1 may be a line printer in which the plurality of nozzles N are provided to extend larger than the width of the recording paper P in the recording head HD.

FIG. 3 is a plan view illustrating an example of an arrangement of the nozzles N in the head module 3. FIG. 3 is an explanatory diagram for describing an example of an

arrangement of four recording heads HD and a total of 8M nozzles N provided in the four recording heads HD in a plan view of the ink jet printer 1 from the +Z direction. In FIG. 3, in order to differentiate the four recording heads HD from each other, the same number as a number added to the end of the reference sign of the head unit HU including the recording head HD is added to the end of the reference sign of the recording head HD. For example, the recording head HD1 indicates the recording head HD included in the head unit HU1.

Each of the four recording heads HD is provided with a plurality of nozzle strings LN. Here, the nozzle string LN is a plurality of nozzles N provided to extend in a row in a predetermined direction. In the present embodiment, a case is assumed in which each nozzle string LN is configured by arranging M nozzles N to extend in a row along the X axis. Hereinafter, the eight nozzle strings LN provided in the head module 3 are also referred to as nozzle strings LNbk1, LNcy1, LNmg1, LNyl1, LNbk2, LNcy2, LNmg2, and LNyl2, respectively. Hereinafter, the nozzle N of the ejection portion D belonging to one nozzle string LN among the plurality of nozzle strings LN may be simply referred to as the ejection portion D belonging to one nozzle string LN. In other words, the ejection portion D having the nozzles N belonging to one nozzle string LN among the plurality of nozzle strings LN may be referred to as the ejection portion D belonging to one nozzle string LN.

Here, the nozzle string LNbk1 of the recording head HD1 and the nozzle string LNbk2 of the recording head HD4 are the nozzle strings LN in which the nozzles N of the ejection portions D ejecting black ink are arranged and are the nozzle strings LN that are paired with each other. The nozzle string LNcy1 of the recording head HD1 and the nozzle string LNcy2 of the recording head HD4 are the nozzle strings LN in which the nozzles N of the ejection portions D ejecting cyan ink are arranged and are the nozzle strings LN that are paired with each other. The nozzle string LNmg1 of the recording head HD2 and the nozzle string LNmg2 of the recording head HD3 are the nozzle strings LN in which the nozzles N of the ejection portions D ejecting magenta ink are arranged and are the nozzle strings LN that are paired with each other. The nozzle string LNyl1 of the recording head HD2 and the nozzle string LNyl2 of the recording head HD3 are the nozzle strings LN in which the nozzles N of the ejection portions D ejecting yellow ink are arranged and are the nozzle strings LN that are paired with each other.

In the present embodiment, as will be described with reference to FIG. 4, in printing of each color, a resolution twice as high as the resolution corresponding to one nozzle string LN is achieved by using two nozzle strings LN that are paired with each other.

The arrangement of the nozzles N in each recording head HD is not limited to the example illustrated in FIG. 3. For example, the number of nozzle strings LN provided in each recording head HD may be one, or may be three or more.

FIG. 4 is an explanatory diagram for describing the normal printing process. FIG. 4 illustrates an example of an image printed on the recording paper P when ejection states of the five ejection portions D[1] to D[5] belonging to the nozzle string LNbk1 and ejection states of the five ejection portions D[1] to D[5] belonging to the nozzle string LNbk2 are normal. In FIG. 4, a case is assumed in which an ink ejection amount designated by the printing signal SI corresponds to a medium dot. For example, when the ejection states of a total of ten ejection portions D belonging to the nozzle strings LNbk1 and LNbk2 are all normal, ink with an ejection amount corresponding to the medium dot is ejected

from the ten ejection portions D through the normal printing process. Consequently, ten medium dots DT1 to DT10 are formed on the recording paper P.

In the example illustrated in FIG. 4, the medium dots DT2, DT4, DT6, DT8, and DT10 corresponding to the five ejection portions D[1] to D[5] included in the head unit HU4 are formed on the same row as the row of the medium dots DT1, DT3, DT5, DT7, and DT9 corresponding to the five ejection portions D[1] to D[5] included in the head unit HU1. For example, the medium dots DT2, DT4, DT6, DT8, and DT10 are formed to fill gaps between the medium dots DT1, DT3, DT5, DT7, and DT9. Consequently, in the present embodiment, a resolution twice as high as that in a case of forming the medium dots DT1, DT3, DT5, DT7, and DT9 on the recording paper P by using only the nozzle string LNbk1 is realized.

FIG. 5 is an explanatory diagram for describing the complementary printing process. In FIG. 5, a case is assumed in which, among the five ejection portions D[1] to D[5] of the head unit HU1 and the five ejection portions D[1] to D[5] of the head unit HU4, an ink ejection state in the ejection portion D[2] of the head unit HU1 is determined as being abnormal by the determination circuit 32. In this case, the ink jet printer 1 executes the complementary printing process instead of the normal printing process. Hereinafter, since the abnormal ejection occurs, the ejection portion D required to be complemented by another ejection portion D in a printing process may be referred to as an abnormal ejection portion Df, and the ejection portion that complements the abnormal ejection portion Df in the complementary printing process may be referred to as a complementing ejection portion Dq.

For example, in the complementary printing process illustrated in FIG. 5, the ejection portion D[2] belonging to the nozzle string LNbk1 is the abnormal ejection portion Df. In this case, complementing ejection portions Dq that complement the abnormal ejection portion Df[2] employ the ejection portion D[1] and the ejection portion D[2] that belong to the nozzle string LNbk2 paired with the nozzle string LNbk1 to which the abnormal ejection portion Df[2] belongs and that correspond to dots DTq2 and DTq4 adjacent to a dot DTf3 corresponding to abnormal ejection portion Df[2] in the normal printing process. In other words, in the complementary printing process exemplified in FIG. 5, the ejection portions D corresponding to the dots DT adjacent to the dot DT corresponding to the abnormal ejection portion Df in the sub-scanning direction are employed as the complementing ejection portions Dq.

In the complementary printing process, compared with the normal printing process illustrated in FIG. 4, an amount of ink ejected from the complementing ejection portions Dq[1] and Dq[2] belonging to the nozzle string LNbk2 is increased, and the supply of the drive signal COM to the abnormal ejection portion Df[2] belonging to the nozzle string LNbk1 is stopped such that driving of the abnormal ejection portion Df[2] is stopped. Consequently, in the complementary printing process, for example, large dots DTq2 and DTq4 are formed instead of the medium dots DT2 and DT4 formed in the normal printing process. Thus, in the complementary printing process, even when the dot DT3 fails to be formed and thus dot omission occurs, it is possible to form the dot DT in an aspect similar to the plurality of dots DT originally to be formed illustrated in FIG. 4 and thus to reduce the degree of deterioration in image quality due to abnormal ejection.

In the present embodiment, complementary control for increasing an amount of ink ejected from the complementing

11

ejection portion Dq in the complementary printing process may be executed by the printing control portion 22 or each head unit HU. For example, the printing control portion 22 may generate the printing signal SI based on the printing data IMG and change the printing signal SI based on the determination information STT. In other words, the printing control portion 22 may generate the printing signal SI based on the printing data IMG and the determination information STT. For example, the printing control portion 22 may stop the transmission of the printing signal SI to the head unit HU based on the determination information STT. In other words, the printing control portion 22 controls the plurality of ejection portions D based on the determination information STT included in the data set DS received by the information reception portion 24. The complementary control executed in each head unit HU will be described later with reference to FIG. 12 and the like.

In the complementary printing process illustrated in FIG. 5, a case has been described in which the abnormal ejection portion Df belongs to the nozzle string LNbk1 and the complementing ejection portion Dq belongs to the nozzle string LNbk2. However, the case is only an example, and the abnormal ejection portion Df and the complementing ejection portion Dq may belong to nozzle strings LN other than the nozzle strings LNbk1 and LNbk2.

In the complementary printing process illustrated in FIG. 5, two ejection portions D that belong to the nozzle string LN ejecting the same color ink as the abnormal ejection portion Df and correspond to two dots DT adjacent to the dot DT corresponding to the abnormal ejection portion Df are used as the complementing ejection portions Dq, but the present disclosure is not limited to such an aspect. For example, the number of the complementing ejection portion Dq may be one, and the complementing ejection portion Dq may be the ejection portion D belonging to the nozzle string LN that ejects ink with a color different from a color of ink ejected from the abnormal ejection portion Df.

In the present embodiment, as described above, the nozzle string LN included in one of the two head units HU and the nozzle string LN included in the other of the two head units HU are paired with each other. Therefore, in the present embodiment, the determination information STT for each nozzle string LN is transmitted between the head units HU in order to execute the complementary control in each head unit HU.

FIG. 6 is an explanatory diagram for describing transmission of the determination information STT. In FIG. 6, a description will be made of transmission of the determination information STT by exemplifying a case where the pieces of determination information STT1 and STT4 are transmitted between the head units HU1 and HU4 that are paired with each other. In FIG. 6, in an example, a case is assumed in which the recording head HD is provided with ten ejection portions D, that is, "2M=10". In FIG. 6, a case is assumed in which abnormal ejection is determined as occurring in the ejection portion D[2] of the recording head HD1. In the example illustrated in FIG. 6, the determination information STT for the ejection portion D in which abnormal ejection is determined as occurring is set to "1", and the determination information STT for the normal ejection portion D is set to "0".

The ejection portions D[1] to D[5] of the recording head HD1 belong to the nozzle string LNbk1, and the ejection portions D[6] to D[10] of the recording head HD1 belong to the nozzle string LNcy1. The ejection portions D[1] to D[5] of the recording head HD4 belong to the nozzle string LNbk2 paired with the nozzle string LNbk1, and the ejection

12

portions D[6] to D[10] of the recording head HD4 belongs to the nozzle string LNcy2 paired with the nozzle string LNcy1.

Pieces of determination information STT1[1] to STT1[10] respectively indicating determination results of the ink ejection states in the ejection portions D[1] to D[10] of the recording head HD1 are stored in a first storage portion 340 of the head unit HU1. The data set DS1 including the determination information STT1[1] to STT1[10] is transmitted from the head unit HU1 to the head unit HU4.

The head unit HU4 stores the determination information STT1[1] to STT1[10] included in the data set DS1 received from the head unit HU1 into a second storage portion 345 of the head unit HU4. Since the determination information STT1[2] indicates "1", the head unit HU4 specifies that the ejection portion D[2] of the recording head HD1 is in an abnormal ejection state. Therefore, as described in FIG. 5, the head unit HU4 uses, as the complementing ejection portions Dq that complement the ejection portion D[2] of the recording head HD1, the ejection portion D[1] and the ejection portion D[2] of the recording head HD4.

Pieces of determination information STT4[1] to STT4[10] respectively indicating determination results of ink ejection states in the ejection portions D[1] to D[10] of the recording head HD4 are stored in the first storage portion 340 of the head unit HU4. The data set DS4 including the determination information STT4[1] to STT4[10] is transmitted from the head unit HU4 to the head unit HU1. The head unit HU1 stores the determination information STT4[1] to STT4[10] included in the data set DS4 received from the head unit HU4 into the second storage portion 345 of the head unit HU1.

In FIG. 6, the head units HU2 and HU3 are not illustrated for clarity, but, as described with reference to FIG. 1, in the present embodiment, the data set DS1 is transmitted from the head unit HU1 to the head unit HU4 via the head units HU2 and HU3. The data set DS4 is transmitted from the head unit HU4 to the head unit HU1 via the head units HU3 and HU2.

FIG. 7 is a diagram illustrating an example of the data set DS including the determination information STT. Although the data set DS1 will be described with reference to FIG. 7, the description also applies to the other data sets DS. In the example illustrated in FIG. 7, the data set DS1 includes recording head information INFhd1 in addition to the determination information STT1. The recording head information INFhd1 may be, for example, information for causing the head unit HU4 paired with the head unit HU1 to specify the determination information STT1 included in the data set DS1. For example, the recording head information INFhd1 may include number information indicating the number of ejection portions D included in the recording head HD1. The recording head information INFhd1 may include arrangement information indicating an arrangement of the ejection portions D included in the recording head HD1. The arrangement information may include information indicating the arrangement order of the ejection portions D. The recording head information INFhd1 may include color information indicating a color of ink ejected from the nozzle string LN included in the recording head HD1.

In a first pattern illustrated in FIG. 7, the recording head information INFhd1 is disposed to be transmitted before the determination information STT1. For example, the recording head information INFhd1 is disposed at the head of the data set DS1. In a second pattern, the determination information STT1 is disposed to be transmitted before the

recording head information INFhd1. For example, the recording head information INFhd1 is disposed at the end of the data set DS1.

A data configuration of the data set DS is not limited to the example illustrated in FIG. 7. For example, when the recording head information INFhd1 is disposed at the end of the data set DS1, head mark information indicating the head of the data set DS1 may be disposed at the head of the data set DS1. Hereinafter, the recording head information INFhd included in each of the data sets DS2 to DS4 may be referred to by being given the same number as the number added to the end of the reference sign of the data set DS including the recording head information INFhd. For example, the recording head information INFhd included in the data set DS4 may be referred to as recording head information INFhd4. The recording head information INFhd is an example of “ejection portion information”.

FIG. 8 is a block diagram illustrating a configuration of the head unit HU1. Configurations of the head units HU2, HU3, and HU4 are the same as the configuration of the head unit HU1. Therefore, description of the configurations of the head units HU2, HU3, and HU4 will be omitted.

As described in FIG. 1, the head unit HU1 includes the recording head HD, the switching circuit 30, the determination circuit 32, and the transmission/reception circuit 34. The head unit HU1 also includes a wiring LHa to which the drive signal COMa is supplied from the drive signal generation unit 4, a wiring LHb to which the drive signal COMb is supplied from the drive signal generation unit 4, a wiring LHs via which the detection signal Vout is supplied to the determination circuit 32, and a power supply line LHd set to a potential VBS. The power supply line LHd is coupled to a lower electrode Zd of a piezoelectric element PZ included in the ejection portion D.

The switching circuit 30 includes 2M switches Wa, 2M switches Wb, 2M switches Ws, and a coupling state designation circuit 300 that designates a coupling state of each switch W. As each switch W, for example, a transmission gate can be used.

The printing signal SI, a latch signal LAT, a change signal CH, a period designation signal Tsig, and a clock signal CL are supplied to the coupling state designation circuit 300 from the printing control portion 22. The determination information STT1[1] to STT1[2M] and the determination information STT4[1] to STT4[2M] for the head unit HU4 paired with the head unit HU1 are supplied to the coupling state designation circuit 300 from the transmission/reception circuit 34. The coupling state designation circuit 300 generates coupling state designation signals Qa[1] to Qa[2M], Qb[1] to Qb[2M], and Qs[1] to Qs[2M], and an inspection target designation signals Qt[1] to Qt[2M], based on at least some of the printing signal SI, the latch signal LAT, the change signal CH, the period designation signal Tsig, the clock signal CL, the determination information STT1[1] to STT1[2M], and the determination information STT4[1] to STT4[2M].

The coupling state designation signal Qa[i] is a signal for designating ON and OFF of the switch Wa[i]. The coupling state designation signal Qb[i] is a signal for designating ON and OFF of the switch Wb[i]. The coupling state designation signal Qs[i] is a signal for designating ON and OFF of the switch Ws[i]. The inspection target designation signal Qt[i] is a signal indicating whether or not the ejection portion D[i] is an inspection target related to an ejection state, and is supplied to the transmission/reception circuit 34.

The switch Wa[i] switches electrical coupling and decoupling between the wiring LHa and the upper electrode Zu[i]

of the piezoelectric element PZ[i] included in the ejection portion D[i] based on the coupling state designation signal Qa[i]. Hereinafter, the upper electrode Zu[i] of the piezoelectric element PZ[i] included in the ejection portion D[i] may be referred to as the upper electrode Zu[i] of the ejection portion D[i]. For example, the switch Wa[i] is turned on when the coupling state designation signal Qa[i] has a high level, and thus electrically couples the wiring LHa to the upper electrode Zu[i] of the ejection portion D[i]. Consequently, the drive signal COMa supplied to the wiring LHa is supplied to the upper electrode Zu[i] of the ejection portion D[i] as the supply drive signal Vin[i]. The switch Wa[i] is turned off when the coupling state designation signal Qa[i] has a low level, and thus electrically decouples the wiring LHa from the upper electrode Zu[i] of the ejection portion D[i].

The switch Wb[i] switches electrical coupling and decoupling between the wiring LHb and the upper electrode Zu[i] of the ejection portion D[i] based on the coupling state designation signal Qb[i]. For example, the switch Wb[i] is turned on when the coupling state designation signal Qb[i] has a high level, and thus electrically couples the wiring LHb to the upper electrode Zu[i] of the ejection portion D[i]. Consequently, the drive signal COMb supplied to the wiring LHb is supplied to the upper electrode Zu[i] of the ejection portion D[i] as the supply drive signal Vin[i]. The switch Wb[i] is turned off when the coupling state designation signal Qb[i] has a low level, and thus electrically decouples the wiring LHb from the upper electrode Zu[i] of the ejection portion D[i].

The switch Ws[i] switches electrical coupling and decoupling between the wiring LHs and the upper electrode Zu[i] of the ejection portion D[i] based on the coupling state designation signal Qs[i]. For example, the switch Ws[i] is turned on when the coupling state designation signal Qs[i] has a high level, and thus electrically couples the wiring LHs to the upper electrode Zu[i] of the ejection portion D[i]. Consequently, the detection signal Vout[i] indicating a potential of the upper electrode Zu[i] of the ejection portion D[i] is supplied to the determination circuit 32 via the wiring LHs. The switch Ws[i] is turned off when the coupling state designation signal Qs[i] has a low level, and thus electrically decouples the wiring LHs from the upper electrode Zu[i] of the ejection portion D[i].

As described with reference to FIG. 1, the determination circuit 32 generates the remaining vibration signal based on the detection signal Vout[i] supplied via the wiring LHs. For example, the determination circuit 32 shapes the detection signal Vout[i] into a waveform suitable for a process of determining an ejection state by amplifying an amplitude of the detection signal Vout[i] and removing a noise component from the detection signal Vout[i]. Consequently, the remaining vibration signal shaped into the waveform suitable for the process of determining the ejection state is generated. For example, the determination circuit 32 may be configured to include a negative feedback amplifier amplifying the detection signal Vout, a low-pass filter attenuating a high frequency component of the detection signal Vout, and a voltage follower generating a low-impedance remaining vibration signal by converting an impedance.

The determination circuit 32 determines an ink ejection state in the ejection portion D[i] based on the remaining vibration signal obtained by shaping the detection signal Vout[i], and generates the determination information STT1[i] indicating the determination result. The determination circuit 32 supplies the determination information STT1[i] to the transmission/reception circuit 34.

As described in FIG. 1, the transmission/reception circuit 34 combines the data set DS1 including the determination information STT1 output from the determination circuit 32 with the data sets DS2, DS3, and DS4 supplied to the terminal TIa of the head unit HU1, and outputs the combined result to the terminal TOa of the head unit HU1. The transmission/reception circuit 34 outputs, for example, the data sets DS1, DS2, DS3, and DS4 supplied to the terminal TIb of the head unit HU1 to the terminal TOb of the head unit HU1.

FIG. 9 is a block diagram illustrating configurations of the coupling state designation circuit 300 and the transmission/reception circuit 34. First, the coupling state designation circuit 300 will be described.

The coupling state designation circuit 300 includes an input shift register 302, a complementing portion 304, a latch portion 306, and a designation signal generation portion 308. In FIG. 9, an outline of the input shift register 302, the complementing portion 304, the latch portion 306, and the designation signal generation portion 308 will be described. Details of the input shift register 302 and the like will be described with reference to FIG. 12.

The input shift register 302 sequentially holds the individual designation signals Sdi[1] to Sdi[2M] serially supplied as the printing signal SI from the printing control portion 22 according to the clock signal CL. Consequently, the individual designation signals Sdi[1] to Sdi[2M] are held in the input shift register 302.

The complementing portion 304 generates the individual designation signal Sdo[1] to Sdo[2M] based on the individual designation signals Sdi[1] to Sdi[2M], the determination information STT1[1] to STT1[2M], and the determination information STT4[1] to STT4[2M]. The complementing portion 304 supplies the individual designation signals Sdo[1] to Sdo[2M] to the latch portion 306. For example, when all ejection states for the ejection portions D[1] to D[2M] of the head unit HU1 and the ejection portions D[1] to D[2M] of the head unit HU4 are normal, the individual designation signal Sdi[1] to Sdi[2M] are supplied from the complementing portion 304 to the latch portion 306 as individual designation signals Sdo[1] to Sdo[2M]. In other words, the complementing portion 304 adjusts ink ejection amounts in the plurality of ejection portions D based on the determination information STT1 and STT4.

The latch portion 306 latches the individual designation signals Sdo[1] to Sdo[2M] supplied from the complementing portion 304 at a timing at which the latch signal LAT rises. The designation signal generation portion 308 generates the coupling state designation signals Qa[i], Qb[i], and Qs[i] and the inspection target designation signal Qt[i] based on the individual designation signal Sdo[i], the latch signal LAT, the change signal CH, and the period designation signal Tsig.

The transmission/reception circuit 34 includes a first storage portion 340, a first switch portion 341, a first shift register 342, a second shift register 343, a second switch portion 344, and a second storage portion 345. In FIG. 9, outlines of the first storage portion 340, the first switch portion 341, the first shift register 342, the second shift register 343, the second switch portion 344, and the second storage portion 345 will be described. Details of the first storage portion 340 and the like will be described with reference to FIG. 13.

The first storage portion 340 stores, for example, the determination information STT1[i] supplied from the determination circuit 32 based on the inspection target designation signal Qt[i]. For example, when ejection state inspec-

tion for the ejection portions D[1] to D[2M] of the head unit HU1 is finished, the first switch portion 341 supplies the determination information STT1[1] to STT1[2M] stored in the first storage portion 340 to the first shift register 342. In the example illustrated in FIG. 9, the first switch portion 341 determines a timing at which the determination information STT1[1] to STT1[2M] is supplied to the first shift register 342 based on the inspection target designation signals Qt[1] to Qt[2M].

The first shift register 342 sequentially outputs the determination information STT1[1] to STT1[2M] according to the clock signal CL. Consequently, the data set DS1 including the determination information STT1[1] to STT1[2M] is supplied to the terminal TOa of the head unit HU1. The first shift register 342 sequentially outputs the data sets DS2 to DS4 serially supplied to the terminal TIa of the head unit HU1 according to the clock signal CL. In other words, the first shift register 342 serially supplies the data sets DS1 to DS4 to the terminal TOa of the head unit HU1 according to the clock signal CL.

The second shift register 343 serially supplies the data sets DS1 to DS4 serially supplied to the terminal TIb of the head unit HU1, to the terminal TOb of the head unit HU1 according to the clock signal CL.

For example, the second switch portion 344 supplies the determination information STT4[1] to STT4[2M] included in the data set DS4 of the head unit HU4 paired with the head unit HU1 to the second storage portion 345. In the example illustrated in FIG. 9, the second switch portion 344 determines a timing at which the determination information STT4[1] to STT4[2M] are supplied to the second storage portion 345 based on the recording head information INFhd4 included in the data set DS4 supplied to the second shift register 343. The second storage portion 345 stores the determination information STT4[1] to STT4[2M] supplied from the second shift register 343 via the second switch portion 344.

Configurations of the coupling state designation circuit 300 and the transmission/reception circuit 34 are not limited to the example illustrated in FIG. 9. For example, a signal for designating a timing of supplying the determination information STT1[1] to STT1[2M] to the first shift register 342 may be supplied from the printing control portion 22 or the like to the first switch portion 341.

FIG. 10 is a timing chart illustrating an example of an operation of the ink jet printer 1. In the present embodiment, when the ink jet printer 1 executes the printing process, one or a plurality of unit periods Tu are set as an operation period of the ink jet printer 1. The ink jet printer 1 according to the present embodiment may drive each ejection portion D in order to perform the printing process in each unit period Tu.

The printing control portion 22 outputs the latch signal LAT having a pulse PlsL and the change signal CH having a pulse PlsC. Consequently, the printing control portion 22 defines the unit period Tu as a period from rising of the pulse PlsL to rising of the next pulse PlsL. The printing control portion 22 divides the unit period Tu into two control periods Tu1 and Tu2 with the pulse PlsC.

The printing signal SI includes, for example, 2M individual designation signals Sdi[1] to Sdi[2M] respectively corresponding to the 2M ejection portions D[1] to D[2M]. The individual designation signal Sdi[i] designates an aspect of driving of the ejection portion D[i] in each unit period Tu when the ink jet printer 1 executes the printing process. When the complementary printing process is executed, an aspect of driving of the ejection portion D[i] is designated by the individual designation signal Sdi[i] and the individual

designation signal Sdo[i] that is generated based on the determination information STT.

The printing control portion 22 supplies the printing signal SI including the individual designation signals Sdi[1] to Sdi[2M] to the coupling state designation circuit 300 in synchronization with the clock signal CL before each unit period Tu in which the printing process is executed. The coupling state designation circuit 300 generates the coupling state designation signals Qa[i], Qb[i] and Qs[i], and the inspection target designation signal Qt[i] based on the individual designation signal Sdi[i] in the unit period Tu.

In the present embodiment, a case is assumed in which the ejection portion D[i] can form one of a large dot, a medium dot smaller than the large dot, and a small dot smaller than the medium dot in the unit period Tu. Hereinafter, an amount of ink corresponding to a large dot may be referred to as a large amount of ink, an amount of ink corresponding to a medium dot may be referred to as a medium amount of ink, and an amount of ink corresponding to a small dot may be referred to as a small amount of ink.

For example, the individual designation signal Sdi[i] designates one driving aspect among five driving aspects such as ejection of a large amount of ink, ejection of a medium amount of ink, ejection of a small amount of ink, non-ejection of ink, and driving that is a determination target when an ejection state is determined in each unit period Tu for the ejection portion D[i]. In the present embodiment, in an example, a case is assumed in which the individual designation signal Sd[i] is a 3-bit digital signal. An example of the relationship between the 3-bit digital signal of the individual designation signal Sd[i] and a designated content is illustrated in FIG. 11 described later.

As illustrated in FIG. 10, the drive signal generation unit 4 outputs the drive signal COMa having a waveform PX and a waveform PY. The waveform PX is a waveform of the drive signal COMa in the control period Tu1, and the waveform PY is a waveform of the drive signal COMa in the control period Tu2.

In the present embodiment, the waveform PX and the waveform PY are set such that a potential difference between the highest potential VHx and the lowest potential VLx of the waveform PX is larger than a potential difference between the highest potential VHy and the lowest potential VLy of the waveform PY. Specifically, when the ejection portion D[i] is driven by the drive signal COMa having the waveform PX, the waveform PX is set such that a medium amount of ink is ejected from the ejection portion D[i]. When the ejection portion D[i] is driven by the drive signal COMa having the waveform PY, the waveform PY is set such that a small amount of ink is ejected from the ejection portion D[i]. The potentials at the start and the end of the waveforms PX and PY are set to a reference potential V0.

When the individual designation signal Sd[i] designates the ejection portion D[i] to form a large dot, the coupling state designation circuit 300 sets the coupling state designation signal Qa[i] to a high level in the control periods Tu1 and Tu2, and sets the coupling state designation signals Qb[i] and Qs[i] to a low level in the unit period Tu. In this case, the ejection portion D[i] is driven by the drive signal COMa having the waveform PX in the control period Tu1 to eject a medium amount of ink, and is driven by the drive signal COMa having the waveform PY in the control period Tu2 to eject a small amount of ink. Consequently, the ejection portion D[i] ejects a large amount of ink in total in the unit period Tu, and thus a large dot is formed on the recording paper P.

When the individual designation signal Sd[i] designates the ejection portion D[i] to form a medium dot, the coupling state designation circuit 300 sets the coupling state designation signal Qa[i] to a high level in the control period Tu1 and to a low level in the control period Tu2, and sets the coupling state designation signals Qb[i] and Qs[i] to a low level in the unit period Tu. In this case, the ejection portion D[i] ejects a medium amount of ink in the unit period Tu, and thus a medium dot is formed on the recording paper P.

When the individual designation signal Sd[i] designates the ejection portion D[i] to form a small dot, the coupling state designation circuit 300 sets the coupling state designation signal Qa[i] to a low level in the control period Tu1 and to a high level in the control period Tu2, and sets the coupling state designation signals Qb[i] and Qs[i] to a low level in the unit period Tu. In this case, the ejection portion D[i] ejects a small amount of ink in the unit period Tu, and thus a small dot is formed on the recording paper P.

When the individual designation signal Sd[i] designates the ejection portion D[i] to perform non-ejection of ink, the coupling state designation circuit 300 sets the coupling state designation signals Qa[i], Qb[i], and Qs[i] to a low level in the unit period Tu. In this case, the ejection portion D[i] does not eject ink and thus does not form dots on the recording paper P in the unit period Tu.

The drive signal generation unit 4 outputs the drive signal COMb having a waveform PS. The waveform PS is a waveform of the drive signal COMb in the unit period Tu. In the present embodiment, the waveform PS is set such that a potential difference between the highest potential VHs and the lowest potential VLs of the waveform PS is smaller than a potential difference between the highest potential VHy and the lowest potential VLy of the waveform PY. Specifically, when the drive signal COMb having the waveform PS is supplied to the ejection portion D[i], the waveform PS is set to drive the ejection portion D[i] such that ink is not ejected from the ejection portion NU. Potentials at the start and the end of the waveform PS are set to the reference potential V0.

The printing control portion 22 outputs the period designation signal Tsig having a pulse PlsT1 and a pulse PlsT2. Consequently, the printing control portion 22 divides the unit period Tu into a control period TSS1 from the start of the pulse PlsL to the start of the pulse PlsT1, a control period TSS2 from the start of the pulse PlsT1 to the start of the pulse PlsT2, and a control period TSS3 from the start of the pulse PlsT2 to the start of the next pulse PlsL.

When the individual designation signal Sd[i] designates the ejection portion D[i] as the determination target ejection portion D, the coupling state designation circuit 300 sets the coupling state designation signal Qa[i] to a low level in the unit period Tu, sets the coupling state designation signal Qb[i] to a high level in the control periods TSS1 and TSS3 and to a low level in the control period TSS2, and sets the coupling state designation signal Qs[i] to a low level in the control periods TSS1 and TSS3 and to a high level in the control period TSS2.

In this case, the determination target ejection portion D is driven by the drive signal COMb having the waveform PS in the control period TSS1. Specifically, the piezoelectric element PZ included in the determination target ejection portion D is displaced by the drive signal COMb having the waveform PS in the control period TSS1. As a result, vibration occurs in the determination target ejection portion D. The vibration occurring in the control period TSS1 remains in the control period TSS2. In the control period TSS2, the upper electrode Zu of the piezoelectric element PZ included in the determination target ejection portion D

changes a potential according to the remaining vibration occurring in the determination target ejection portion D. In other words, in the control period TSS2, the upper electrode Zu of the piezoelectric element PZ included in the determination target ejection portion D indicates a potential corresponding to an electromotive force of the piezoelectric element PZ caused by the remaining vibration occurring in the determination target ejection portion D. The potential of the upper electrode Zu may be detected as the detection signal Vout in the control period TSS2.

FIG. 11 is an explanatory diagram for describing generation of the coupling state designation signals Qa[i], Qb[i], and Qs[i] in the designation signal generation portion 308. As described with reference to FIG. 10, the individual designation signal Sdo[i] designates a driving aspect of the ejection portion D[i] by using three bits such as b1, b2, and b3. In the present embodiment, among the bits b1, b2, and b3, it is assumed that the bit b1 is the most significant bit and the bit b3 is the least significant bit. When all ejection states of the ejection portions D[1] to D[2M] are normal, the individual designation signal Sdo[i] is set to the same value as that of the individual designation signal Sdi[i] included in the printing signal SI.

The individual designation signal Sdo[i] has a value among a value (1, 1, 0) for designating formation of a large dot, a value (1, 0, 0) for designating formation of a medium dot, a value (0, 1, 0) for designating formation of a small dot, a value (0, 0, 0) for designating non-ejection of ink, and a value (1, 1, 1) for designating driving of the ejection portion D that is a determination target. The designation signal generation portion 308 sets the coupling state designation signal Qa[i] to a high level in the control periods Tu1 and Tu2 when the individual designation signal Sdo[i] has the value (1, 1, 0), and sets the coupling state designation signal Qa[i] to a high level in the control period Tu1 when the individual designation signal Sdo[i] has the value (1, 0, 0). The designation signal generation portion 308 sets the coupling state designation signal Qa[i] to a high level in the control period Tu2 when the individual designation signal Sdo[i] has the value (0, 1, 0), and sets the coupling state designation signal Qb[s] to a high level in the control periods TSS1 and TSS3 and sets the coupling state designation signal Qs[i] to a high level in the control period TSS2 when the individual designation signal Sdo[i] has the value (1, 1, 1). The designation signal generation portion 308 sets each signal to a low level when the above conditions are not satisfied.

FIG. 12 is a diagram illustrating an example of a circuit configuration of the coupling state designation circuit 300. The coupling state designation circuit 300 illustrated in FIG. 12 is an example of the coupling state designation circuit 300 of the head unit HU1. The coupling state designation circuit 300 includes the input shift register 302, the complementing portion 304, the latch portion 306, and the designation signal generation portion 308, as described in FIG. 9.

The input shift register 302 has, for example, 2M holding circuits FFsi coupled in cascade. As the holding circuit FFsi, for example, flip-flop circuits may be used.

Among the holding circuits FFsi[1] to FFsi[2M], the holding circuits FFsi[1] to FFsi[2M-1] sequentially transmit the printing signal SI to the holding circuit FFsi in the subsequent stage according to the clock signal CL. For example, the 3-bit individual designation signal Sdi is serially supplied as the printing signal SI from the printing control portion 22 to the first-stage holding circuit FFsi[1] in synchronization with the clock signal CL. The holding circuit FFsi[1] temporarily holds the 3-bit individual designation

signal Sdi and sequentially transmits the individual designation signal Sdi to the holding circuit FFsi[2] in the subsequent stage according to the clock signal CL. Similarly, the holding circuits FFsi[2] to FFsi[2M-1] temporarily hold the 3-bit individual designation signal Sdi transmitted from the holding circuit FFsi in the previous stage, and sequentially transmit the individual designation signal Sdi to the holding circuit FFsi in the subsequent stage according to the clock signal CL. The individual designation signal Sdi is transmitted to the holding circuit FFsi[2M] in the final stage such that the holding circuit FFsi[i] temporarily holds the 3-bit individual designation signal Sdi[i].

The complementing portion 304 has 2M adder circuits ADD, 2M logical sum circuits OR, 2M switches AS, and 2M switches BS. The adder circuit ADD[i] adds a result of exclusive OR of the upper 2 bits of the individual designation signal Sdi[i] to the 3-bit individual designation signal Sdi[i] held in the holding circuit FFsi[i], and supplies a 3-bit signal indicating the addition result to the switch AS[i].

The switch AS[i] supplies one of the 3-bit individual designation signal Sdi[i] held in the holding circuit FFsi[i] and the 3-bit signal supplied from the adder circuit ADD[i] to the switch BS[i] based on the signal supplied from the logical sum circuit OR[i]. For example, the switch AS[i] supplies the 3-bit signal supplied from the adder circuit ADD[i] to the switch BS[i] when the signal supplied from the logical sum circuit OR[i] indicates "1". The switch AS[i] supplies the 3-bit individual designation signal Sdi[i] to the switch BS[i] when the signal supplied from the logical sum circuit OR[i] indicates "0".

The logical sum circuit OR[1] supplies a signal indicating a result of a logical sum of "0" and the determination information STT4[1] to the switch AS[1]. Each logical sum circuit OR[i] of the logical sum circuits OR[2] to OR[2M] supplies a signal indicating a result of a logical sum of the determination information STT4[i-1] and the determination information STT4[i] to the switch AS[i].

In other words, the signal supplied from the logical sum circuit OR[i] to the switch AS[i] corresponds to a complementary control signal for controlling whether or not an ink ejection amount in the ejection portion D[i] is increased from an ink ejection amount defined by the individual designation signal Sdi[i] based on the printing data IMG. For example, when the determination information STT4[i] indicates abnormal ejection, the signal supplied from the logical sum circuit OR[i] to the switch AS[i], that is, the complementary control signal indicates that an ink ejection amount in the ejection portion D[i] of the head unit HU1 is increased from an ink ejection amount defined by the individual designation signal Sdi[i].

When the individual designation signal Sdi[i] designates formation of a large dot, an ink ejection amount in the ejection portion D[i] of the head unit HU1 is not increased from an ink ejection amount defined by the individual designation signal Sdi[i]. In the example illustrated in FIG. 12, in a case where the individual designation signal Sdi[i] for the head unit HU1 designates non-ejection of ink even when the determination information STT4[i] indicates abnormal ejection, an ink ejection amount in the ejection portion D[i] of the head unit HU1 is not increased from an ink ejection amount defined by the individual designation signal Sdi[i]. Even in a case where the individual designation signal Sdi[i] for the head unit HU1 designates non-ejection of ink when the determination information STT4[i] indicates abnormal ejection, an ink ejection amount in the

ejection portion $D[i]$ of the head unit $HU1$ may be increased from an ink ejection amount defined by the individual designation signal $Sdi[i]$.

The switch $BS[i]$ supplies one of the 3-bit signal supplied from the switch $AS[i]$ and the signal indicating “0” to the latch circuit $LTsd[i]$ included in the latch portion **306** as a 3-bit individual designation signal $Sdo[i]$ based on the determination information $STT1[i]$

The latch portion **306** has $2M$ latch circuits $LTsd$. The latch circuit $LTsd[i]$ latches the 3-bit individual designation signal $Sdo[i]$ supplied from the switch $BS[i]$ at a timing when the latch signal LAT rises. The latch circuit $LTsd[i]$ supplies the latched 3-bit individual designation signal $Sdo[i]$ to a decoder $DC[i]$ and a logical product circuit $AND[i]$ included in the designation signal generation portion **308**.

The designation signal generation portion **308** has $2M$ decoders DC s and $2M$ logical product circuits AND . The decoder $DC[i]$ generates the coupling state designation signals $Qa[i]$ and $Qb[i]$ and $Qs[i]$ based on the 3-bit individual designation signal $Sdo[i]$, the latch signal LAT , the change signal CH , and the period designation signal $Tsig$. The logical product circuit $AND[i]$ generates the inspection target designation signal $Qt[i]$ by calculating a logical product of the period designation signal $Tsig$ and the 3-bit individual designation signal $Sdo[i]$.

Here, a circuit configuration of the coupling state designation circuit **300** of each of the head units $HU2$ to $HU4$ is the same as that of the coupling state designation circuit **300** of the head unit $HU1$ except for the determination information STT supplied to the complementing portion **304**. However, in the head units $HU3$ and $HU4$, “0” is supplied to the logical sum circuit $OR[2M]$ instead of the logical sum circuit $OR[1]$. For example, in the head unit $HU4$, each logical sum circuit $OR[i]$ of the logical sum circuits $OR[1]$ to $OR[2M-1]$ supplies a signal indicating a result of a logical sum of the determination information $STT1[i]$ and the determination information $STT1[i+1]$ to the switch $AS[i]$, and the logical sum circuit $OR[2M]$ supplies a signal indicating a result of a logical sum of “0” and the determination information $STT1[2M]$ to the switch $AS[2M]$.

A circuit configuration of the coupling state designation circuit **300** is not limited to the example illustrated in FIG. **12**. For example, when there is one complementing ejection portion Dq for one abnormal ejection portion Df , the logical sum circuits $OR[1]$ to $OR[2M]$ may be omitted. In this case, for example, the determination information $STT4[i]$ may be supplied to the switch $AS[i]$. For example, when there is one complementing ejection portion Dq for one abnormal ejection portion Df , the complementing portion **304** may include a switch that alternately switches the determination information $STT4$ supplied to the switch $AS[i]$ between the determination information $STT4[i-1]$ and the determination information $STT4[i]$ instead of the logical sum circuit $OR[i]$.

FIG. **13** is a diagram illustrating an example of a circuit configuration of the transmission/reception circuit **34**. The transmission/reception circuit **34** illustrated in FIG. **13** is an example of the transmission/reception circuit **34** of the head unit $HU1$. As described with reference to FIG. **9**, the transmission/reception circuit **34** includes the first storage portion **340**, the first switch portion **341**, the first shift register **342**, the second shift register **343**, the second switch portion **344**, and the second storage portion **345**.

The first storage portion **340** has $2M$ latch circuits $LT1$. The latch circuit $LT1[i]$ latches the determination information $STT1$ as the determination information $STT1[i]$ at the timing when the inspection target designation signal $Qt[i]$ rises. The latch circuit $LT1[i]$ supplies the latched determi-

nation information $STT1[i]$ to the switch $BS[i]$ of the coupling state designation circuit **300**. The latch circuit $LT1[i]$ supplies the latched determination information $STT1[i]$ to the switch $SW1[i]$ included in the first switch portion **341**.

The first switch portion **341** has a first switch controller $SCT1$ and $2M$ switches $SW1$. The first switch controller $SCT1$ generates a switch control signal $Lsig$ based on, for example, the inspection target designation signals $Qt[1]$ to $Qt[2M]$. For example, the first switch controller $SCT1$ has $2M$ determination flags respectively corresponding to the inspection target designation signals $Qt[1]$ to $Qt[2M]$, and, whenever the inspection target designation signal Qt indicating “1” is supplied, the determination flag corresponding to the inspection target designation signal Qt is set to “1”. When all of the $2M$ determination flags are set to “1”, the first switch controller $SCT1$ sets the switch control signal $Lsig$ to a high level, and sets the switch control signal $Lsig$ to a low level after a predetermined time elapses from setting of the switch control signal $Lsig$ to the high level. For example, the first switch controller $SCT1$ sets the switch control signal $Lsig$ to a low level before the data set $DS2$ is supplied to the holding circuit $FF1[1]$ described later. The first switch controller $SCT1$ resets the $2M$ determination flags to “0” when all of the $2M$ determination flags are set to “1”.

The switch $SW1[i]$ is turned on when the switch control signal $Lsig$ has a high level, and supplies the determination information $STT1[i]$ supplied from the latch circuit $LT1[i]$ to the holding circuit $FF1$ included in the first shift register **342**. The switch $SW1[i]$ is turned off when the switch control signal $Lsig$ has a low level, and thus electrically decouples, for example, the latch circuit $LT1[i]$ to the holding circuit $FF1[i]$.

The first shift register **342** includes, for example, “ $2M+\alpha$ ” holding circuits $FF1$ coupled in cascade. “ α ” is, for example, the number of holding circuits $FF1$ required to hold the recording head information $INFhd$ included in the data set DS . In FIG. **13**, the α holding circuits $FF1$ are illustrated as holding circuits $FF1a$. As the holding circuit $FF1$, for example, a flip-flop circuit may be used.

The holding circuit $FF1[i]$ holds the determination information $STT1[i]$ supplied from the switch $SW1[i]$ before the data set $DS2$ is supplied to the holding circuit $FF1[1]$. The transmission/reception circuit **34** holds the recording head information $INFhd1$ in the holding circuit $FF1a$ before the data set $DS2$ is supplied to the holding circuit $FF1[1]$. The holding circuit $FF1[i]$ and the holding circuit $FF1a$ sequentially transmit the held information to the holding circuit $FF1$ in the subsequent stage according to the clock signal CL . The holding circuit $FF1a$ in the final stage sequentially transmits the information supplied from the previous-stage holding circuit $FF1$ in synchronization with the clock signal CL to the terminal TOa of the head unit $HU1$ according to the clock signal CL . Consequently, the data set $DS1$ is supplied to the terminal TOa of the head unit $HU1$.

Here, the first shift registers **342** of the other head units HU also operate similarly to the first shift register **342** of the head unit $HU1$. Therefore, the data sets $DS2$ to $DS4$ are serially supplied from the transmission/reception circuit **34** of the head unit $HU2$ to the holding circuit $FF1[1]$ of the head unit $HU1$ in synchronization with the clock signal CL .

The holding circuit $FF1[1]$ temporarily holds the data sets $DS2$ to $DS4$ supplied serially in synchronization with the clock signal CL , and sequentially transmits the data sets $DS2$ to $DS4$ to the holding circuit $FF1[2]$ in the subsequent stage according to the clock signal CL . Similarly, the holding

circuits FF1[2] to FF1[2M] and the holding circuit FF1a temporarily hold the information transmitted from the holding circuit FF1 in the previous stage and sequentially transmit the information to the holding circuit FF1 in the subsequent stage according to the clock signal CL. Consequently, the data sets DS2 to DS4 are supplied to the terminal TOa of the head unit HU1 after the data set DS1.

As described above, in the head unit HU1 according to the present embodiment, transmission of the determination information STT1 to the other head units HU is not executed whenever determination for one ejection portion D among the ejection portions D[1] to D[2M] is finished but is executed when determination for all of the ejection portions D[1] to D[2M] is finished.

Here, a predetermined process may be executed before and after a determination process such that a transmission process of transmitting the determination information STT1 to another head unit HU and the like and the determination process of determining an ink ejection state in the ejection portion D do not interfere with each other. In this case, the number of times of execution of the predetermined process increases as the number of times of execution of the transmission process increases. As the number of times of execution of the predetermined process increases, the processing time required to transmit the determination information STT1 for all the ejection portions D increases. In the present embodiment, compared with a case where the determination information STT1 is transmitted to another head unit HU whenever determination for one ejection portion D among the ejection portions D[1] to D[2M] is finished, the number of times of execution of the transmission process is can be reduced, and thus it is possible to reduce the time required for a series of processes for transmitting the determination information STT1 for all of the ejection portions D.

The second shift register 343 has, for example, “2M+ α ” holding circuits FF2 coupled in cascade. Here, “ α ” is, for example, the number of holding circuits FF2 required to hold the recording head information INFhd included in the data set DS. In FIG. 13, the α holding circuits FF2 are illustrated as the holding circuits FF2a. As the holding circuit FF2, for example, a flip-flop circuit may be used.

The data sets DS1 to DS4 that are supplied to the terminal T1b of the head unit HU1 in synchronization with the clock signal CL are serially supplied to the holding circuit FF2[1]. The holding circuit FF2[1] temporarily holds the data sets DS1 to DS4 serially supplied in synchronization with the clock signal CL, and sequentially transmits the data sets DS1 to DS4 to the holding circuit FF2[2] in the subsequent stage according to the clock signal CL. Similarly, the holding circuits FF2[2] to FF2[2M] and the holding circuit FF2a temporarily hold the information transmitted from the holding circuit FF2 in the previous stage, and sequentially transmit the information to the holding circuit FF2 in the subsequent stage according to the clock signal CL. The holding circuit FF2a in the final stage sequentially transmits the information supplied from the holding circuit FF2 in the previous stage in synchronization with the clock signal CL, to the terminal TOb of the head unit HU1 according to the clock signal CL. Consequently, the data sets DS1 to DS4 are supplied to the terminal TOa of the head unit HU1.

The second switch portion 344 has a second switch controller SCT2 and 2M switches SW2. The second switch controller SCT2 generates, for example, a switch control signal PSEL based on the recording head information INFhd4 included in the data set DS4. For example, the second switch controller SCT2 analyzes the recording head information INFhd included in the data set DS supplied to

the holding circuit FF2[1], and determines whether or not the data set DS supplied to the holding circuit FF2[1] is the data set DS4 for the head unit HU4 paired with the head unit HU1.

When the data set DS4 is supplied to the holding circuit FF2[1], the second switch controller SCT2 specifies a timing at which the determination information STT4[1] to STT4[2M] are held in the holding circuits FF2[1] to FF2[2M] based on the recording head information INFhd4 included in the data set DS4. For example, the second switch controller SCT2 sets the switch control signal PSEL to a high level in accordance with a timing at which the determination information STT4[1] to STT4[2M] is transmitted from the holding circuits FF2[1] to FF2[2M] to the holding circuit FF2 in the subsequent stage. For example, the second switch controller SCT2 sets the switch control signal PSEL to the high level, and then sets the switch control signal PSEL to a low level according to the clock signal CL.

The switch SW2[i] is turned on when the switch control signal PSEL has a high level, and thus supplies the determination information STT4[i] supplied from the holding circuit FF2[i] to the latch circuit LT2[i] included in the second storage portion 345. The switch SW2[i] is turned off when the switch control signal PSEL has a low level, and thus electrically decouples, for example, the latch circuit LT2[i] from the holding circuit FF2[i].

The second storage portion 345 has 2M latch circuits LT2. The latch circuit LT2[i] latches the determination information STT4[i] supplied from the switch SW2[i] at a timing when the latch signal LAT rises. The latch circuit LT2[i] supplies the latched determination information STT4[i] to the complementing portion 304 of the coupling state designation circuit 300.

A circuit configuration of each of the transmission/reception circuits 34 of the head units HU2 to HU4 is the same as that of the transmission/reception circuit 34 of the head unit HU1.

A circuit configuration of the transmission/reception circuit 34 is not limited to the example illustrated in FIG. 13. For example, the switch control signal Lsig may be supplied from the printing control portion 22 or the like to the switches SW1[1] to SW[2M]. In this case, the first switch controller SCT1 may be omitted. For example, when the data set DS does not include the recording head information INFhd4, the holding circuit FF1a and the holding circuit FF2a may be omitted. For example, the second storage portion 345 may be provided in the coupling state designation circuit 300.

For example, the second storage portion 345 may be omitted when the coupling state designation circuit 300 has a storage portion that stores logical sum results from logical sum circuits OR[1] to OR[2M].

As described above, in the present embodiment, the head unit HU includes the plurality of ejection portions D, the determination circuit 32 that determines an ink ejection state of each ejection portion D, and the transmission/reception circuit 34 that transmits the determination information STT indicating a determination result for each ejection portion D from the determination circuit 32 and the recording head information INF including information indicating the number of the plurality of ejection portions D to the control unit 2 as one data set DS. The control unit 2 includes the information reception portion 24 that receives the data set DS transmitted from the head unit HU, and the printing control portion 22 that controls the plurality of ejection portions D based on the data set DS received by the information reception portion 24.

In other words, in the present embodiment, the plurality of determination information STT corresponding to the plurality of ejection portions D and the recording head information INF including the information indicating the number of the plurality of ejection portions D are transmitted as one data set DS from the head unit HU to the control unit 2. Thus, in the present embodiment, compared with a case where the determination information STT is transmitted to another head unit HU whenever determination for one ejection portion D among the plurality of ejection portions D is finished, it is possible to suppress an increase in the time required for the series of processes for transmitting the determination information STT for all of the ejection portions D due to the increase in the number of the ejection portions D.

In the present embodiment, based on the plurality of pieces of determination information STT included in one data set DS, it is possible to determine whether or not an ink ejection state of each ejection portion D of the head unit HU corresponding to the data set DS is abnormal. In the present embodiment, when cause information indicating a cause of an abnormal ejection state is included in the determination information STT, the cause of the abnormal ejection state can be specified based on determination information included in the data set DS. For example, in the present embodiment, a cause of the abnormal ejection state can be specified based on the cause information included in the determination information STT and information for identifying a plurality of causes of the abnormal ejection state.

In the present embodiment, when the recording head information INF includes information indicating an arrangement of the plurality of ejection portions D, it is possible to easily specify the ejection portion D of which an ink ejection state is abnormal based on the recording head information INF and the determination information STT. In the present embodiment, the printing signal that defines an ejection amount of ink ejected from each ejection portion D can be changed according to an ejection state of each ejection portion D specified by the plurality of determination information STT included in the data set DS. In the present embodiment, transmission of the printing signal SI to the head unit HU can be stopped according to an ejection state of each ejection portion D specified by the plurality of determination information STT included in the data set DS.

In the present embodiment, the transmission/reception circuit 34 has the first shift register 342 that sequentially outputs a plurality of pieces of determination information STT. Therefore, each head unit HU serially outputs the plurality of pieces of determination information STT from the first shift register 342, and can thus transmit the plurality of pieces of determination information STT as one data set DS to the other head units HU and the control unit 2.

Specifically, the first shift register 342 has a plurality of latch circuits LT1 coupled in cascade. For example, the first shift register 342 outputs the plurality of pieces of determination information STT held in the plurality of latch circuits LT1 as one data set DS from the latch circuit LT1 in the final stage among the plurality of latch circuits LT1.

Therefore, in the present embodiment, the number of wirings for transmitting the plurality of pieces of determination information STT between the head units HU and the number of wirings for transmitting the plurality of pieces of determination information STT from the head unit HU to the control unit 2 can be reduced compared with a case of outputting the plurality of pieces of determination information STT in parallel.

2. MODIFICATION EXAMPLES

Each of the above forms can be variously modified. Specific modification aspects will be exemplified below.

Two or more aspects freely selected from the following exemplifications may be combined with each other as appropriate within the scope in which the aspects are not contradictory to each other. In the modification examples described below, an element having the same operation or function as that in the embodiment will be given the reference numeral used in the above description, and detailed description thereof will be omitted as appropriate.

Modification Example 1

In the above-described embodiment, a description has been made of an example of a case where the determination circuit 32 determines the determination target ejection portions D one by one, but the present disclosure is not limited to such an aspect. For example, the determination circuit 32 may include a first determination portion that determines an ink ejection state of one of the two different ejection portions D and a second determination portion that determines an ink ejection state of the other of the two ejection portions D. The second determination portion may be operated in parallel with the first determination portion.

For example, the first determination portion may determine an ink ejection state of the odd-numbered ejection portion D, and the second determination portion may determine an ink ejection state of the even-numbered ejection portion D. Alternatively, the first determination portion may determine ink ejection states of the ejection portions D[1] to D[M], and the second determination portion may determine ink ejection states of the ejection portions D[M+1] to D[2M].

When the determination circuit 32 includes the first determination portion and the second determination portion, for example, the wiring LHs illustrated in FIG. 8 includes a wiring used to supply the detection signal Vout for the ejection portion D to be determined by the first determination portion to the first determination portion, and a wiring used to supply the detection signal Vout for the ejection portion D to be determined by the second determination portion to the second determination portion. Similarly, the wiring from the determination circuit 32 to the first storage portion 340 includes a wiring to which the determination information STT for the ejection portion D determined by the first determination portion is transmitted and a wiring to which the determination information STT for the ejection portion D determined by the second determination portion is transmitted.

The determination circuit 32 may have three or more determination portions. Also in Modification Example 1, it is possible to achieve the same effect as that of the above-described embodiment. In Modification Example 1, since the second determination portion can be operated in parallel with the first determination portion, determination for the plurality of ejection portions D can be efficiently performed.

Modification Example 2

In the embodiment and Modification Example 1 described above, a description has been made of an example of a case where the transmission/reception circuit 34 transmits the data set DS output from the first shift register 342 to the control unit 2 and the like, but the present disclosure is not limited to such an aspect. For example, as illustrated in FIG.

14, the head unit HU may include a transmission/reception circuit 35 including a first compression portion 348a compressing the data set DS output from the first shift register 342 instead of the transmission/reception circuit 34 illustrated in FIG. 1.

FIG. 14 is a block diagram illustrating a configuration of the transmission/reception circuit 35 according to Modification Example 2. The transmission/reception circuit 35 is the same as the transmission/reception circuit 34 except that a first differential reception portion 346a, a first decoding portion 347a, a first compression portion 348a, a first differential transmission portion 349a, a second differential reception portion 346b, a second decoding portion 347b, a second compression portion 348b, and a second differential transmission portion 349b are added to the transmission/reception circuit 34 illustrated in FIG. 9.

The first compression portion 348a compresses the data sets DS1 to DS4 output from the first shift register 342 to generate compressed data sets DSc1 to DSc4. For example, the first compression portion 348a may compress the data sets DS1 to DS4 through lossless compression. Specifically, the first compression portion 348a may compress the data sets DS1 to DS4 through run-length compression or a compression method such as Huffman coding.

The first differential transmission portion 349a generates differential data signals DScd1 to DScd4 by converting the single-end compressed data sets DSc1 to DSc4 supplied from the first compression portion 348a into differential signals. The first differential transmission portion 349a supplies the differential data signals DScd1 to DScd4 to the terminal TOa of the head unit HU1. For example, the first differential transmission portion 349a transmits the differential data signals DScd1 to DScd4 that are low voltage differential signals to the terminal TOa of the head unit HU1. Specifically, the first differential transmission portion 349a transmits the differential data signals DScd1 to DScd4 based on the low voltage differential signaling (LVDS) standard.

The first differential reception portion 346a receives the differential data signals DScd2 to DScd4 supplied to the terminal TIa of the head unit HU1. For example, the first differential reception portion 346a receives the differential data signals DScd2 to DScd4 based on the LVDS standard. The first differential reception portion 346a converts the differential data signals DScd2 to DScd4 into single-end compressed data sets DSc2 to DSc4.

The first decoding portion 347a restores the data sets DS2 to DS4 by decoding the single-end compressed data sets DSc2 to DSc4 supplied from the first differential reception portion 346a. The first decoding portion 347a supplies the data sets DS2 to DS4 restored from the compressed data sets DSc2 to DSc4 to the first shift register 342.

The second differential reception portion 346b is similar to the first differential reception portion 346a, the second decoding portion 347b is similar to the first decoding portion 347a, and the second compression portion 348b is similar to the first compression portion 348a. The second differential transmission portion 349b is similar to the first differential transmission portion 349a. Thus, detailed description of the second differential reception portion 346b, the second decoding portion 347b, the second compression portion 348b, and the second differential transmission portion 349b is omitted.

The second differential reception portion 346b receives the differential data signals DScd1 to DScd4 supplied to the terminal TIb of the head unit HU1, and converts the differential data signals DScd1 to DScd4 into single-end compressed data sets DSc1 to DSc4.

The second decoding portion 347b restores the data sets DS1 to DS4 by decoding the single-end compressed data sets DSc1 to DSc4 supplied from the second differential reception portion 346b. The second decoding portion 347b supplies the data sets DS1 to DS4 restored from the compressed data sets DSc1 to DSc4 to the second shift register 343.

The second compression portion 348b compresses the data sets DS1 to DS4 output from the second shift register 343 to generate compressed data sets DSc1 to DSc4. The second compression portion 348b is another example of the “encoding portion”.

The second differential transmission portion 349b generates the differential data signals DScd1 to DScd4 by converting the single-end compressed data sets DSc1 to DSc4 supplied from the second compression portion 348b into differential signals. The second differential transmission portion 349b supplies the differential data signals DScd1 to DScd4 to the terminal TOb of the head unit HU1. The second differential transmission portion 349b is another example of the “differential transmission circuit”.

A configuration of the transmission/reception circuit 35 according to Modification Example 2 is not limited to the example illustrated in FIG. 14. For example, the first differential reception portion 346a, the first differential transmission portion 349a, the second differential reception portion 346b, and the second differential transmission portion 349b may be omitted. For example, the first decoding portion 347a, the first compression portion 348a, the second decoding portion 347b, and the second compression portion 348b may be omitted.

Alternatively, among the first decoding portion 347a, the first compression portion 348a, the second decoding portion 347b, and the second compression portion 348b, only the first decoding portion 347a may be omitted. In this case, the first compression portion 348a compresses the data set DS1 to generate the compressed data set DSc1. The first compression portion 348a does not perform a compression process on the compressed data sets DSc2 to DSc4 supplied from the first differential reception portion 346a via the first shift register 342. In other words, the compressed data sets DSc2 to DSc4 are supplied to the first differential transmission portion 349a from the first differential reception portion 346a via the first shift register 342.

The first compression portion 348a may compress only the determination information STT of the recording head information INFhd and the determination information STT included in the data set DS. In this case, the second decoding portion 347b may be included in the second switch portion 344, and thus the second compression portion 348b may be omitted. For example, when the compressed data set DSc4 is supplied to the second shift register 343, the second decoding portion 347b of the head unit HU1 stores the data set DS4 restored from the compressed data set DSc4 into the second storage portion 345. In this case, the compressed data sets DSc1 to DSc4 are supplied to the second differential transmission portion 349b from the second differential reception portion 346b via the second shift register 343.

Also in Modification Example 2, it is possible to achieve the same effects as those of the above-described embodiment and Modification Example 1. In Modification Example 2, since the data set DS is compressed, it is possible to reduce an amount of the data set DS transmitted between the head units HU or between the head unit HU and the control unit 2. Since the data set DS is compressed in a lossless manner, when the compressed data set DSc is decoded, the same information as the data set DS before compression can

be obtained. Consequently, it is possible to accurately transmit the determination information STT indicating the ejection portion D in an abnormal ejection state.

When the compressed data set DSc is transmitted as the differential data signal DScd, it is possible to improve the resistance to noise compared with a case where the single-end compressed data set DSc is transmitted. Particularly, when the differential data signal DScd is transmitted based on the LVDS standard, the differential data signal DScd can be stably transmitted.

Modification Example 3

A description has been made of an example of a case where the determination information STT is information indicating whether or not an ink ejection state of the ejection portion D is abnormal in the embodiment, Modification Example 1, and Modification Example 2 described above, but the present disclosure is not limited to thereto. For example, as illustrated in FIG. 15, the determination information STT may be information indicating any one of a normal ejection state, an abnormal ejection state, and a failure in the ejection portion D. Alternatively, as illustrated in FIG. 16, the determination information STT may be information including cause information indicating a cause of an abnormal ejection state of the ejection portion D.

FIG. 15 is an explanatory diagram for describing an example of the determination information STT according to Modification Example 3. In the example illustrated in FIG. 15, the determination information STT indicates a state of the ejection portion D with 2 bits such as pieces of determination information STTa and STTb. For example, the determination information STTa is set to "0" when an ink ejection state of the ejection portion D is normal, and is set to "1" when an ink ejection state of the ejection portion D is not normal. In other words, the determination information STTa is information indicating whether or not an ink ejection state of the ejection portion D is abnormal. The determination information STTb is set to "1" when it is determined that the ejection portion D fails, and is set to "0" when it is determined that the ejection portion D does not fail. For example, the determination circuit 32 may have a history of the ejection portion D that has been determined as being in abnormal ejection state, and determine that the ejection portion D determined as being in the abnormal ejection state fails even when a maintenance process is performed a predetermined number of times or more by the maintenance unit 6.

When in ink ejection state of the ejection portion D is normal, a normal printing process is executed. When an ink ejection state of the ejection portion D is normal, a complementary printing process and a maintenance process are executed. When the ejection portion D fails, the complementary printing process is executed. When the ejection portion D fails, the printing control portion 22 may stop transmission of the printing signal SI to the head unit HU based on the determination information STT.

FIG. 16 is an explanatory diagram for describing another example of the determination information STT according to Modification Example 3. In the example illustrated in FIG. 16, the determination information STT indicates a state of the ejection portion D and a cause of an abnormal ejection state of the ejection portion D with 5 bits such as pieces of determination information STTa, STTb, STTc, STTd, and STTe. For example, the determination information STTa is set to "0" when an ink ejection state of the ejection portion D is normal, and is set to "1" when an ink ejection state of

the ejection portion D is not normal. The determination information STTb is set to "1" when it is determined that the ejection portion D fails, and is set to "0" when it is determined that the ejection portion D does not fail. The determination information STTc is set to "1" when the abnormal ejection occurs due to inclusion of bubbles. The determination information STTd is set to "1" when the abnormal ejection occurs due to thickening of ink. The determination information STTe is set to "1" when the abnormal ejection occurs due to adhesion of a foreign substance. In this case, the determination information STTc, STTd, and STTe correspond to "cause information".

In the example illustrated in FIG. 16, the determination information STTa may be omitted. In this case, the head unit HU or the like may obtain information corresponding to the determination information STTa from a result of a logical sum of the pieces of determination information STTb, STTc, STTd, and STTe. The determination information STT may indicate the five items such as normal, bubble, thickening, adhesion, and failure illustrated in FIG. 16 with 3-bit data. When the determination information STT includes cause information indicating any one of a plurality of causes of the abnormal ejection state of the ejection portion D, the data set DS may include information for identifying the plurality of causes. For example, the recording head information INFhd may include information for identifying a plurality of causes.

Specifically, the information for identifying the plurality of causes is, for example, information indicating that the cause of abnormal ejection indicated by (STTa, STTb, STTc, STTd, STTe)=(1, 0, 1, 0, 0) is inclusion of bubbles in the determination information STT illustrated in FIG. 16. Also in Modification Example 3, it is possible to achieve the same effects as those of the embodiment, Modification Example 1, and Modification Example 2 described above.

Modification Example 4

In the embodiment and the modification examples from the Modification Example 1 to Modification Example 3, a description has been made of an example of a case where the plurality of nozzles N belonging to the nozzle string LN are arranged in one row, but the present disclosure is not limited to such an aspect. For example, the plurality of nozzles N belonging to the nozzle string LN may be arranged in two rows as illustrated in FIG. 17.

FIG. 17 is an explanatory diagram for describing an arrangement of the nozzles N according to Modification Example 4. In FIG. 17, six patterns are illustrated as an example of the arrangement of the plurality of nozzles N belonging to the nozzle string LN.

In the example illustrated in FIG. 17, arrangement information regarding a value "01" and arrangement information regarding a value "02" indicate that the plurality of nozzles N belonging to the nozzle string LN are arranged in one row. The arrangement information regarding the value "01" indicates that nozzle numbers are sequentially assigned from the nozzle N located in the +X direction. The nozzle numbers are, for example, numbers assigned to the nozzles N in order to identify the plurality of nozzles N. The arrangement information regarding the value "02" indicates that the nozzle numbers are sequentially assigned from the nozzle N located in the -X direction.

Arrangement information regarding a value "03" and arrangement information regarding a value "04" indicate that the plurality of nozzles N belonging to the nozzle string LN are arranged in two rows. The arrangement information

regarding the value "03" indicates that the nozzle numbers are sequentially assigned from the nozzles N belonging to the row located in the -Y direction of the two rows. The arrangement information regarding the value "04" indicates that the nozzle numbers are alternately assigned to the nozzles N belonging to the row located in the -Y direction and the nozzles N belonging to the row located in the +Y direction from the nozzles N located in the +X direction.

Arrangement information regarding a value "05" and arrangement information regarding a value "06" indicate that the plurality of nozzles N belonging to the nozzle string LN are arranged in zigzag. The zigzag arrangement indicates, for example, that positions in the +Y direction of the even-numbered nozzles N and the odd-numbered nozzles N from the +X direction in FIG. 17 are different from each other. The arrangement information regarding the value "05" indicates that the nozzle numbers are sequentially assigned from the nozzle N belonging to the row located in the -Y direction of the two rows. The arrangement information regarding the value "06" indicates that the nozzle numbers are alternately assigned to the nozzles N belonging to the row located in the -Y direction and the nozzles N belonging to the row located in the +Y direction from the nozzles N located in the +X direction.

Also in Modification Example 4, it is possible to achieve the same effects as those of the embodiment and the modification examples of the Modification Examples 1 to 3 described above.

Modification Example 5

In the embodiment and the modification examples from Modification Example 1 to Modification Example 4 described above, a description has been made of an example of a case where the data set DS4 for the head unit HU4 is supplied to the head unit HU1 via the head units HU3 and HU2, but the present disclosure is not limited to such an aspect. For example, as illustrated in FIG. 18, the head module 3 may have a path via which the data set DS4 for the head unit HU4 is supplied to the head unit HU1 without passing through the head units HU3 and HU2.

FIG. 18 is a block diagram illustrating an example of a configuration of an ink jet printer 1A according to Modification Example 5. The ink jet printer 1A illustrated in FIG. 18 is the same as the ink jet printer 1 illustrated in FIG. 1 except for a coupling relationship among the four head units HU.

In the example illustrated in FIG. 18, the terminal TOB of each of the head units HU1 to HU4 is not coupled to other head units HU.

The terminal TOA of the head unit HU1 is electrically coupled to the terminal TIB of the head unit HU4 and the control unit 2. The terminal TOA of the head unit HU2 is electrically coupled to the terminal TIA of the head unit HU1 and the terminal TIB of the head unit HU3.

The terminal TOA of the head unit HU3 is electrically coupled to the terminals TIA and TIB of the head unit HU2. The terminal TOA of the head unit HU4 is electrically coupled to the terminal TIA of the head unit HU3 and the terminal TIB of the head unit HU1. Next, a description will be made of a flow of each data set DS when the head units HU1, HU2, HU3, and HU4 are coupled as illustrated in FIG. 18.

The flow of the data sets DS1 to DS4 supplied to the control unit 2 is the same as that in the ink jet printer 1 illustrated in FIG. 1. In other words, the head unit HU1

transmits the data sets DS1 to DS4 to the control unit 2 in an order of the data sets DS1, DS2, DS3, and DS4.

The data set DS1 is supplied from the terminal TOA of the head unit HU1 to the terminal TIB of the head unit HU4 without passing through the head units HU2 and HU3. The data set DS2 is supplied from the terminal TOA of the head unit HU2 to the terminal TIB of the head unit HU3 without passing through the head unit HU1. The data set DS3 is supplied from the terminal TOA of the head unit HU3 to the terminal TIB of the head unit HU2 without passing through the head unit HU1. The data set DS4 is supplied from the terminal TOA of the head unit HU4 to the terminal TIB of the head unit HU1 without passing through the head units HU3 and HU2.

In the example illustrated in FIG. 18, for example, the second switch portion 344 and the second storage portion 345 illustrated in FIG. 9 and the like may be omitted. In this case, for example, in the head unit HU1, the supply of the clock signal CL to the second shift register 343 may be stopped after the determination information STT4[1] to STT4[2M] is held in the second shift register 343. Also in Modification Example 5, it is possible to achieve the same effects as those of the embodiment and the modification examples of the Modification Examples 1 to 4 described above. In Modification Example 5, since the data set DS initially supplied to the terminal TIB of each head unit HU is the data set DS for the paired head unit HU, the data set DS for the paired head unit HU can be easily specified.

Modification Example 6

In the embodiment and the modification examples from Modification Example 1 to Modification Example 5 described above, a description has been made of an example of a case where, when determination for all of the 2M ejection portions D included in the head unit HU is finished, the determination information STT is transmitted to another head unit HU, but the present disclosure is not limited to such an aspect. For example, the transmission of the determination information STT to another head unit HU or the like may be executed when determination for two or more ejection portions D among the ejection portions D[1] to D[2M] is finished. Specifically, for example, the transmission of the determination information STT to another head unit HU or the like may be executed when determination for M ejection portions D among the ejection portions D[1] to D[2M] is finished.

Also in Modification Example 6, the plurality of pieces of determination information STT are transmitted to another head unit HU or the like as one data set DS. Therefore, also in Modification Example 6, it is possible to achieve the same effects as those of the embodiment and the modification examples from Modification Example 1 to Modification Example 5 described above.

Modification Example 7

In the embodiment and the modification examples from Modification Example 1 to Modification Example 6 described above, a description has been made of an example of a case where the head module 3 has a plurality of head units HU, but the present disclosure is not limited to such an aspect. For example, the number of head units HU included in the head module 3 may be one. Also in this case, the plurality of pieces of determination information STT are transmitted to the control unit 2 as one data set DS. Therefore, also in Modification Example 7, compared with the

33

case where the determination information STT is transmitted to the control unit 2 whenever determination for one ejection portion D among the plurality of ejection portions D is finished, it is possible to suppress an increase in the time required for the series of processes for transmitting the determination information STT for all of the ejection portions D due to the increase in the number of the ejection portions D.

Modification Example 8

In the embodiment and the modification examples from Modification Example 1 to Modification Example 7 described above, a description has been made of an example of a case where each head unit HU has the complementing portion 304, but the present disclosure is not limited to such an aspect. For example, the complementing portion 304, the second shift register 343, the second switch portion 344, and the second storage portion 345 may be omitted. In this case, the first storage portion 340 may be omitted. When the first storage portion 340 is omitted, the supply of the clock signal CL to the first shift register 342 may be stopped, for example, until the determination information STT1[1] to STT1[2M] is stored therein.

Also in Modification Example 8, a plurality of pieces of determination information STT are transmitted to the control unit 2 as one data set DS. Thus, also in Modification Example 8, compared with a case where the determination information STT is transmitted to the control unit 2 whenever determination for one ejection portion D among the plurality of ejection portions D is finished, it is possible to suppress an increase in the time required for the series of processes for transmitting the determination information STT for all of the ejection portions D due to the increase in the number of the ejection portions D.

What is claimed is:

1. A head unit control device controlling a head unit including a plurality of ejection portions that includes a first ejection portion and a second ejection portion and a determination circuit that determines a liquid ejection state of the first ejection portion and determines a liquid ejection state of the second ejection portion, the head unit control device comprising:

at least one processor constituting

a reception portion that receives, as one data set, determination result information including first determination information indicating a determination result of the liquid ejection state of the first ejection portion from the determination circuit and second determination information indicating a determination result of the liquid ejection state of the second ejection portion from the determination circuit, and ejection portion information including information indicating the number of the plurality of ejection portions included in the head unit, from the head unit; and

an ejection control portion that controls the plurality of ejection portions based on the one data set received by the reception portion.

2. The head unit control device according to claim 1, wherein

the first determination information includes information indicating whether or not the liquid ejection state of the first ejection portion is abnormal.

3. The head unit control device according to claim 1, wherein

34

the first determination information includes cause information indicating a cause of an abnormal liquid ejection state of the first ejection portion when the liquid ejection state of the first ejection portion is abnormal.

4. The head unit control device according to claim 3, wherein

the cause information indicates any one of a plurality of causes of the abnormal liquid ejection state of the first ejection portion, and

the one data set includes information for identifying the plurality of causes.

5. The head unit control device according to claim 1, wherein

the ejection portion information includes information indicating an arrangement of the plurality of ejection portions.

6. The head unit control device according to claim 1, wherein

the ejection control portion

generates a printing signal that defines an ejection amount of a liquid ejected from the first ejection portion and an ejection amount of the liquid ejected from the second ejection portion based on image information indicating an image to be formed on a medium, and

changes the printing signal based on the determination result information.

7. The head unit control device according to claim 6, wherein

the ejection control portion stops transmission of the printing signal to the head unit based on the determination result information.

8. A head unit controlled by a head unit control device, the head unit comprising:

a plurality of ejection portions that includes a first ejection portion and a second ejection portion;

a determination circuit that determines a liquid ejection state of the first ejection portion and determines a liquid ejection state of the second ejection portion; and

a transmission circuit that transmits, as one data set, determination result information including first determination information indicating a determination result of the liquid ejection state of the first ejection portion and second determination information indicating a determination result of the liquid ejection state of the second ejection portion, and ejection portion information including information indicating the number of the plurality of ejection portions, to the head unit control device.

9. A liquid ejection device comprising:

a head unit; and

a head unit control device that controls the head unit, wherein

the head unit includes

a plurality of ejection portions that includes a first ejection portion and a second ejection portion,

a determination circuit that determines a liquid ejection state of the first ejection portion and determines a liquid ejection state of the second ejection portion, and

a transmission circuit that transmits, as one data set, determination result information including first determination information indicating a determination result of the liquid ejection state of the first ejection portion and second determination information indicating a determination result of the liquid ejection state of the second ejection portion, and

ejection portion information including information indicating the number of the plurality of ejection portions, to the head unit control device, and the head unit control device includes a reception portion that receives the one data set 5 transmitted from the head unit, and an ejection control portion that controls the plurality of ejection portions based on the one data set received by the reception portion.

* * * * *