

US011453993B2

(12) **United States Patent**
Lauterslager

(10) **Patent No.:** **US 11,453,993 B2**
(45) **Date of Patent:** ***Sep. 27, 2022**

(54) **QUICK COUPLER WITH HYDRAULIC COUPLING MANIFOLD**

(71) Applicant: **Caterpillar Inc.**, Deerfield, IL (US)

(72) Inventor: **Peter Lauterslager**, Oss (NL)

(73) Assignee: **Caterpillar Inc.**, Peoria, IL (US)

(*) Notice: Subject to any disclaimer, the term of this patent is extended or adjusted under 35 U.S.C. 154(b) by 511 days.

This patent is subject to a terminal disclaimer.

(21) Appl. No.: **16/442,775**

(22) Filed: **Jun. 17, 2019**

(65) **Prior Publication Data**

US 2020/0392691 A1 Dec. 17, 2020

(51) **Int. Cl.**
E02F 3/36 (2006.01)

(52) **U.S. Cl.**
CPC **E02F 3/3622** (2013.01); **E02F 3/3654** (2013.01); **E02F 3/3663** (2013.01)

(58) **Field of Classification Search**
None
See application file for complete search history.

(56) **References Cited**

U.S. PATENT DOCUMENTS

2,689,978 A	9/1954	Roger	
5,465,513 A	11/1995	Sonerud	
6,813,851 B2	11/2004	Mieger et al.	
7,464,967 B2	12/2008	Mieger et al.	
7,735,249 B2	6/2010	Muller	
7,963,054 B2 *	6/2011	Wimmer E02F 3/3627 37/468

9,377,146 B2	6/2016	Van Hooft et al.	
9,970,177 B2	5/2018	Koestler et al.	
11,053,660 B2 *	7/2021	Lauterslager E02F 3/3618
2014/0321956 A1 *	10/2014	Frey E02F 3/364 414/723
2020/0217040 A1 *	7/2020	Hill F16L 37/56

FOREIGN PATENT DOCUMENTS

DE	10200836	7/2003
DE	202010003410	8/2011
EP	2466182 A1	6/2011
EP	2487300	8/2012
EP	2995725 A1	3/2016
NL	1017043	7/2002
WO	2004072387	8/2004
WO	2012080213 A1	6/2012

* cited by examiner

Primary Examiner — Michael S Lowe

(74) *Attorney, Agent, or Firm* — Calfee, Halter & Griswold LLP

(57) **ABSTRACT**

A coupling assembly for releasably mounting, and hydraulically coupling, a tool to a work machine. The coupling assembly includes a mount attachable to the work machine and configured to receive the tool in a mounted position of the tool, a rigid retaining body movable in translation relative to the mount along a translation axis between a retaining position for retaining the tool to the mount and a release position for releasing the tool from the mount, a first and a second actuator operable to move the retaining body between the retaining and release positions, and a hydraulic coupling manifold movable in translation relative to the mount along the translation axis for hydraulically coupling the tool to the machine, wherein the hydraulic coupling manifold uses the first and second actuators as guides for moving along the translation axis.

20 Claims, 10 Drawing Sheets

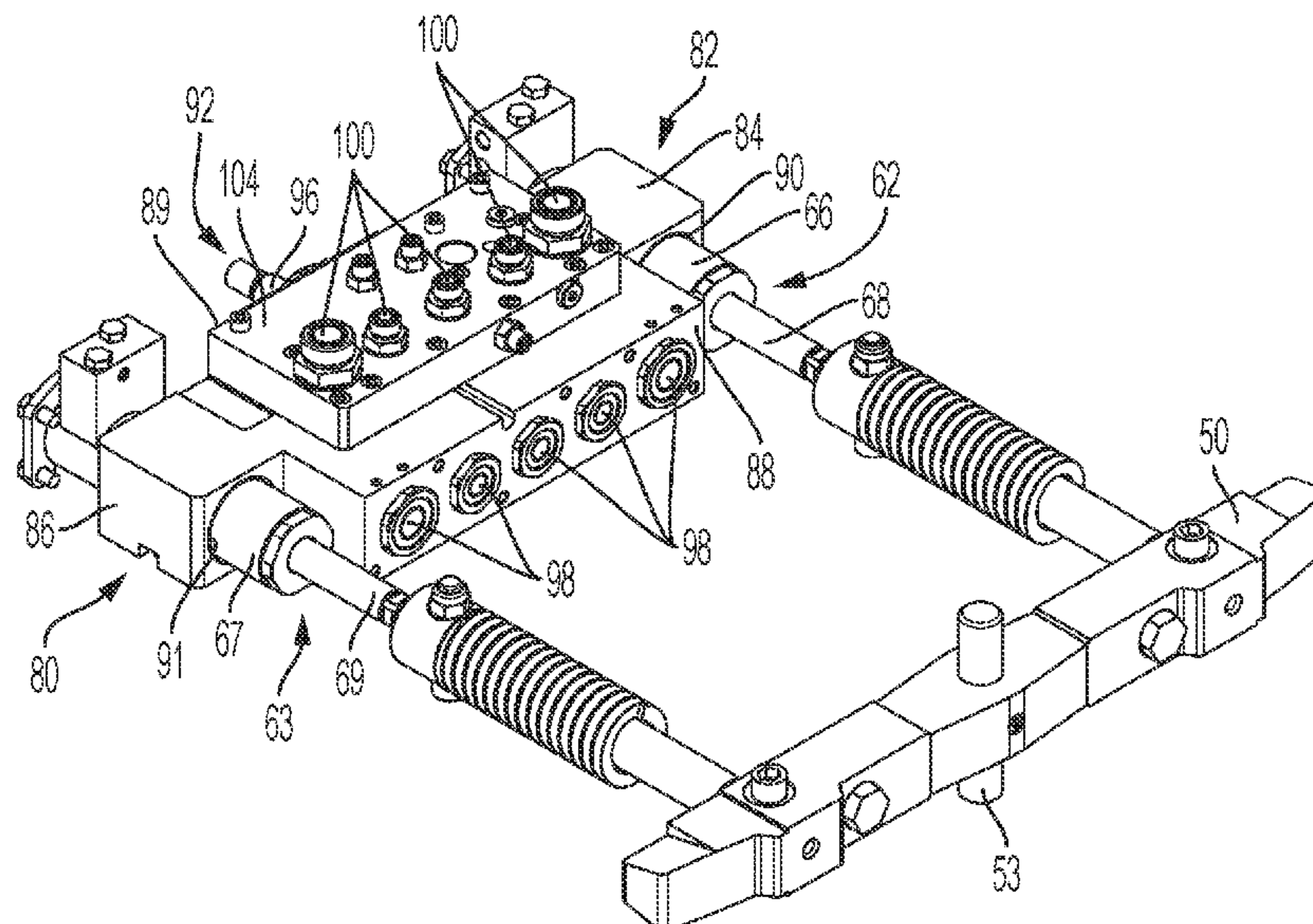

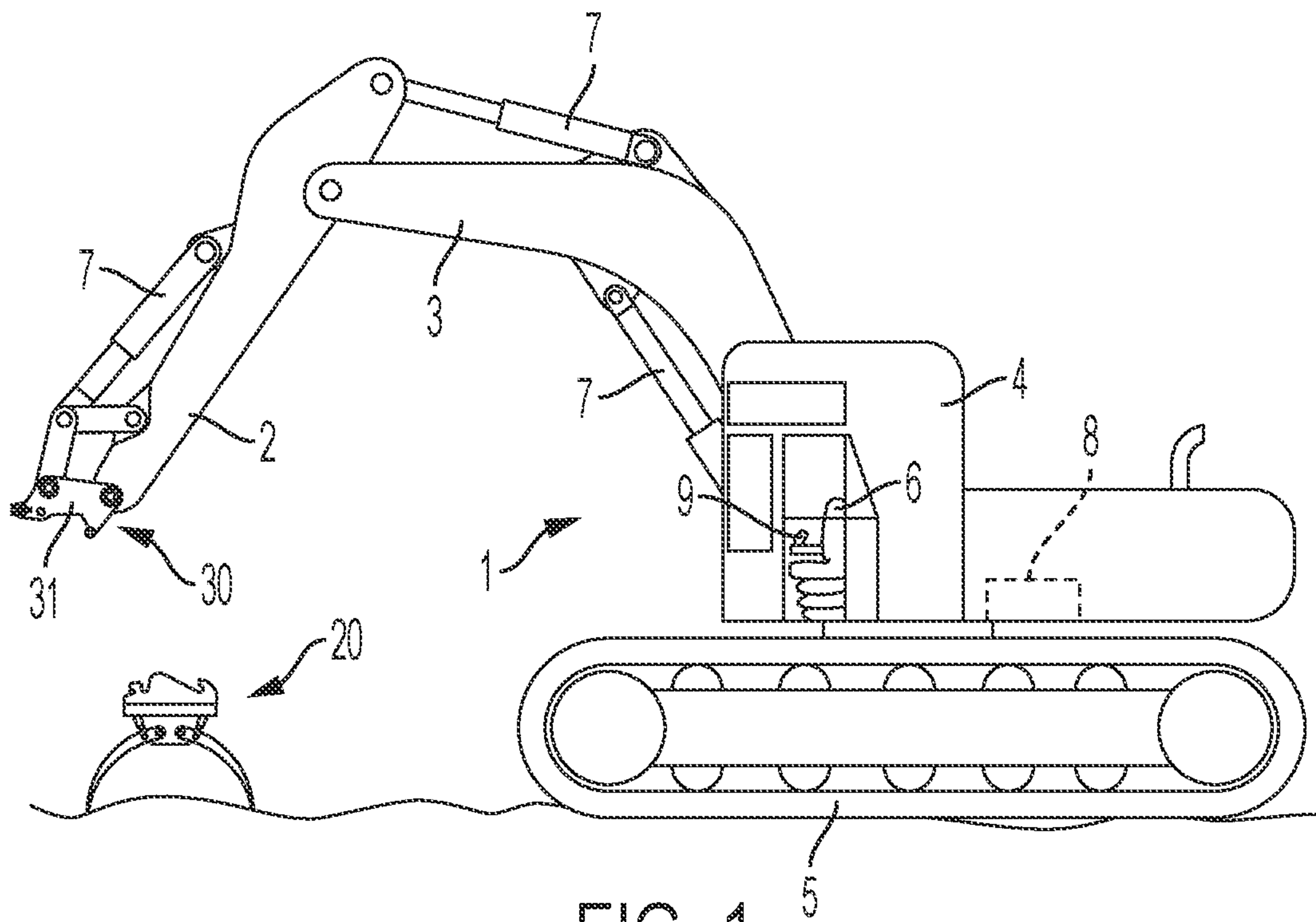

FIG. 1

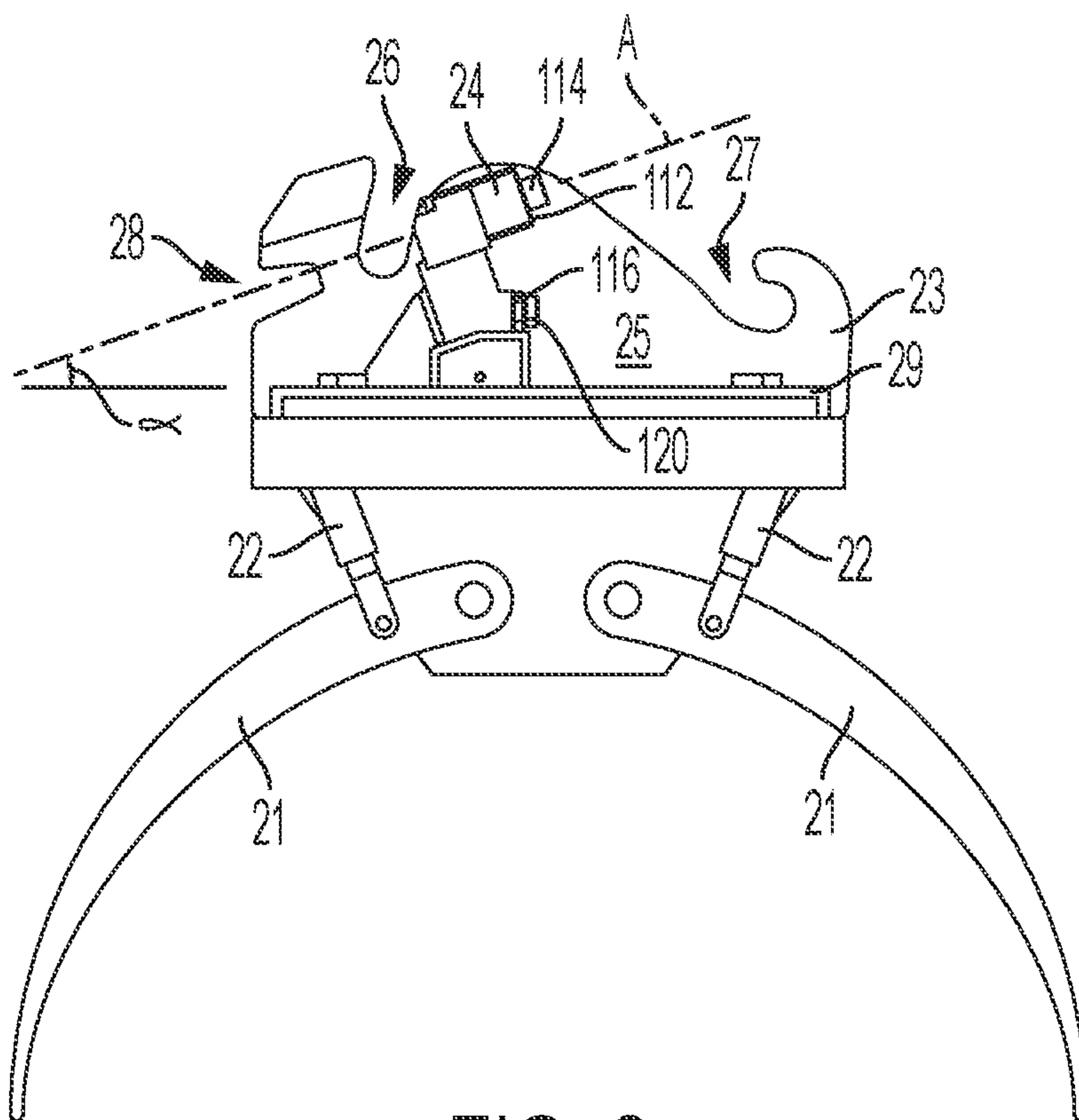

FIG. 2

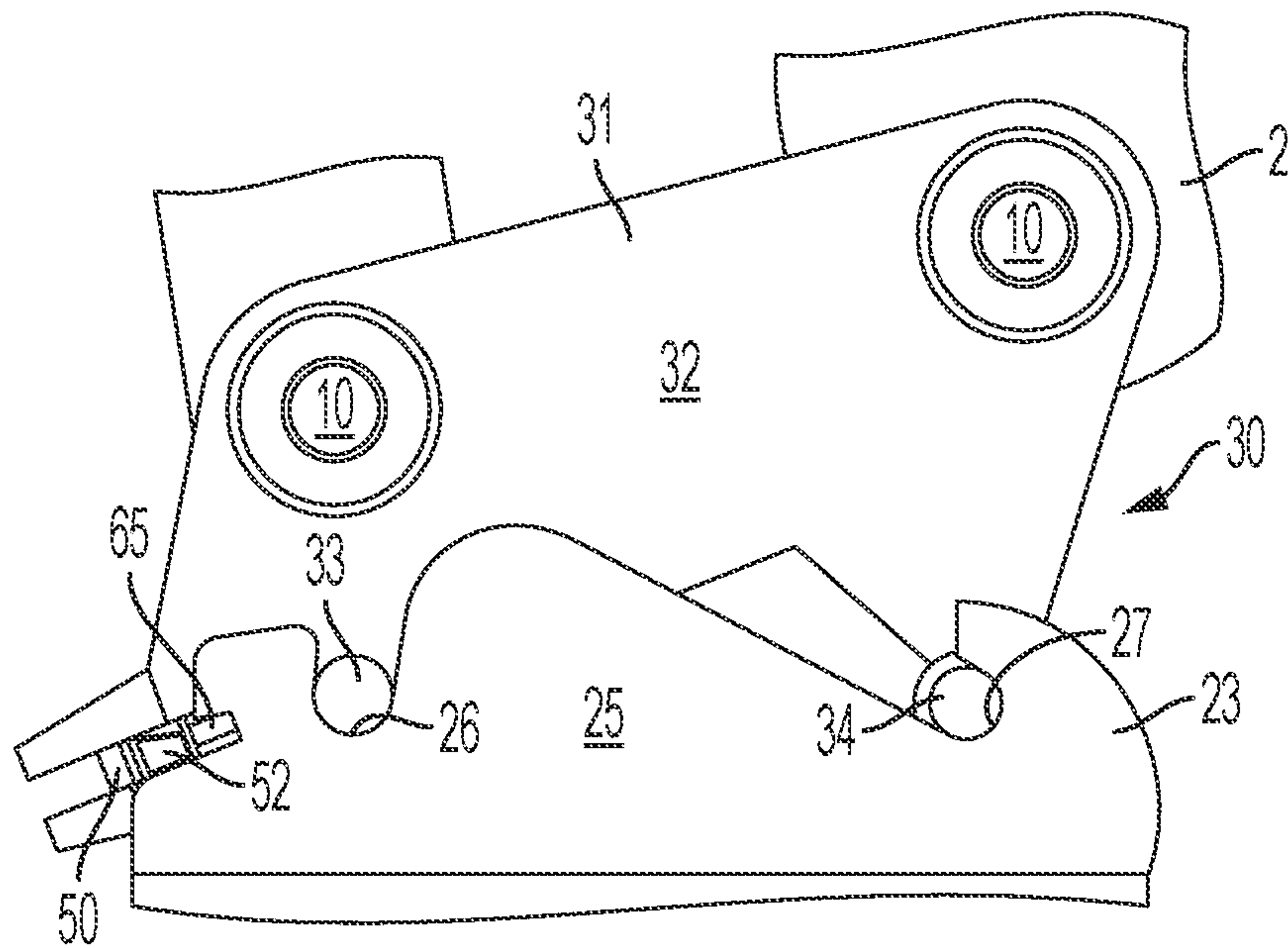

FIG. 3

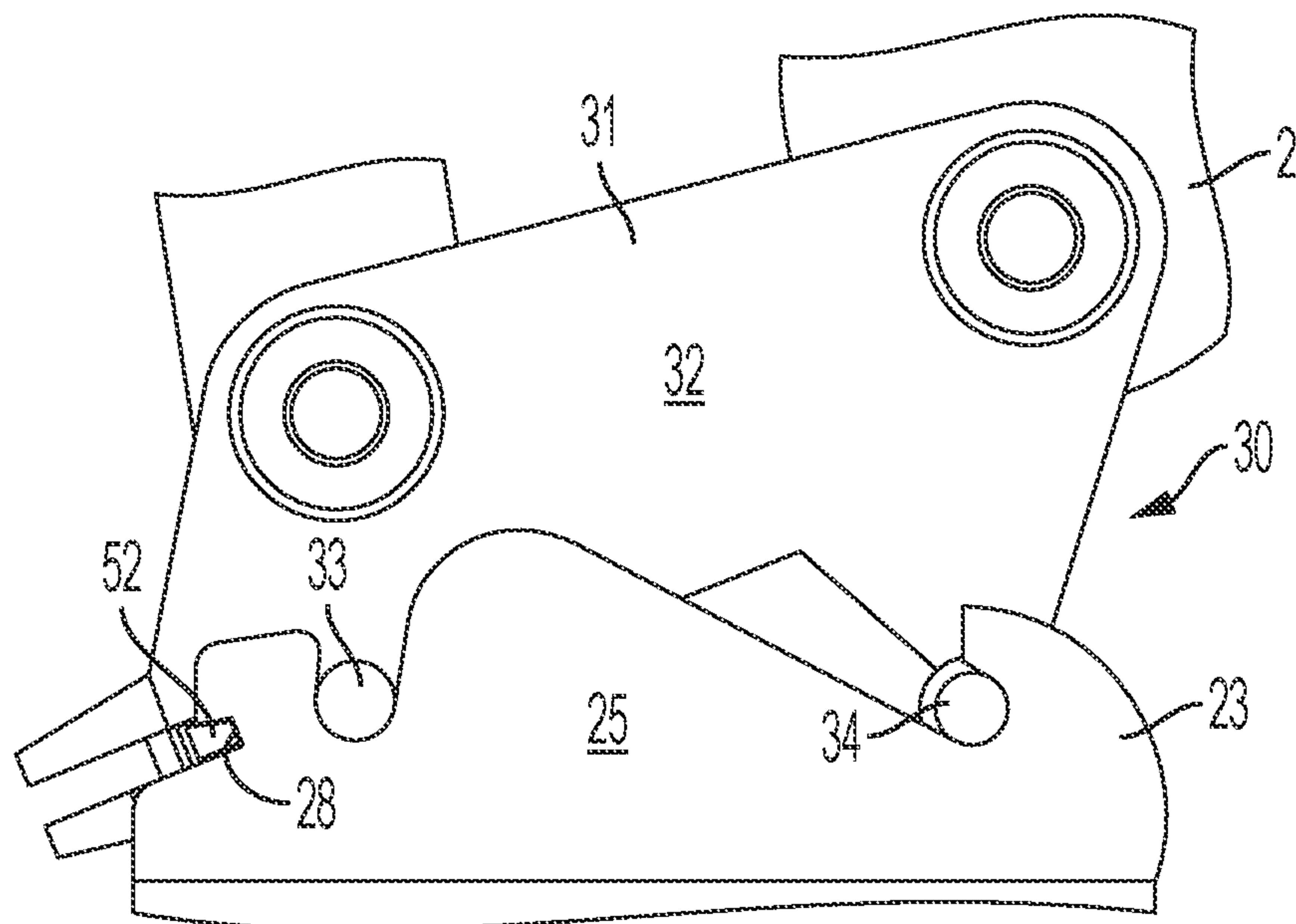

FIG. 4

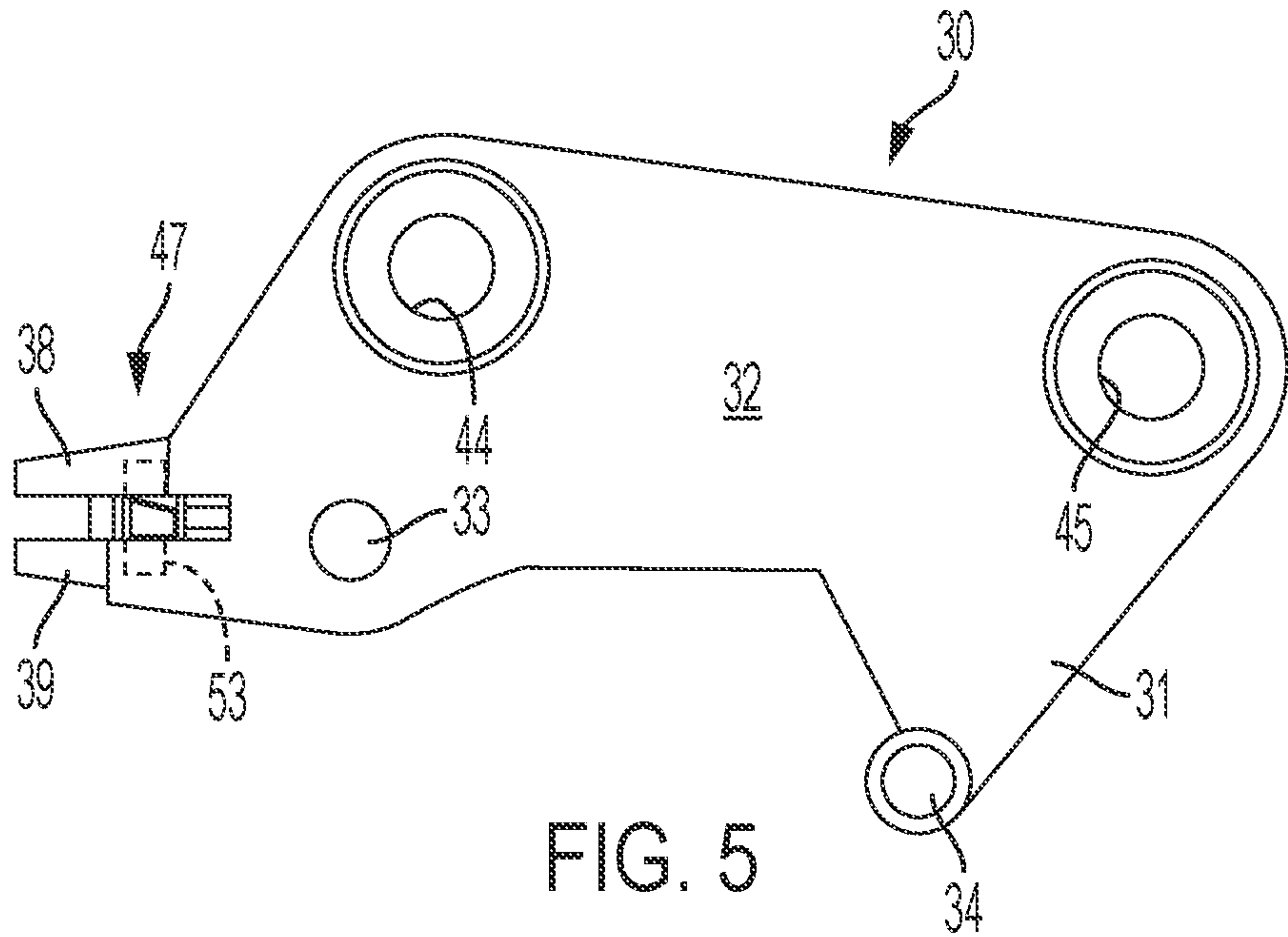

FIG. 5

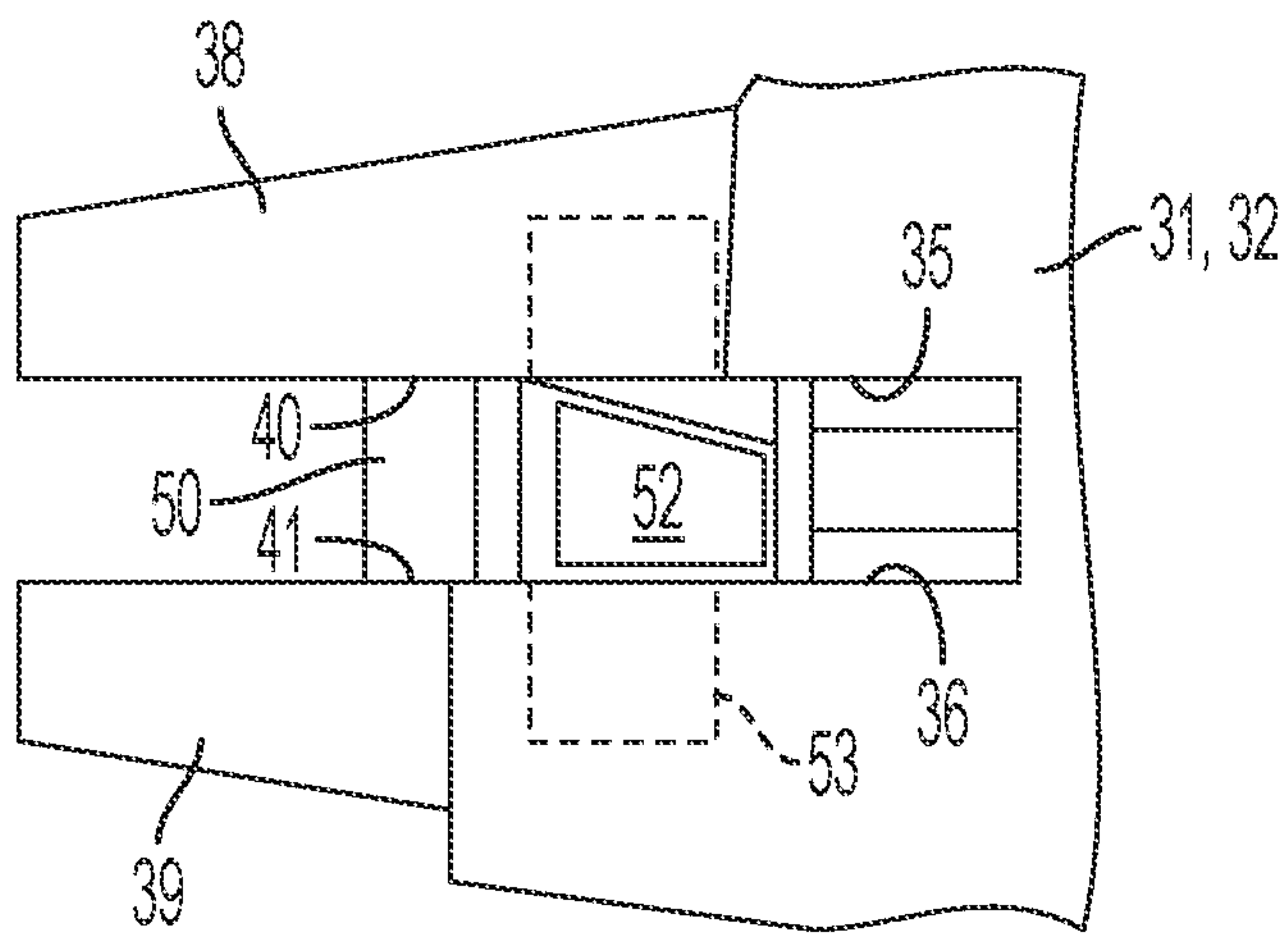

FIG. 6

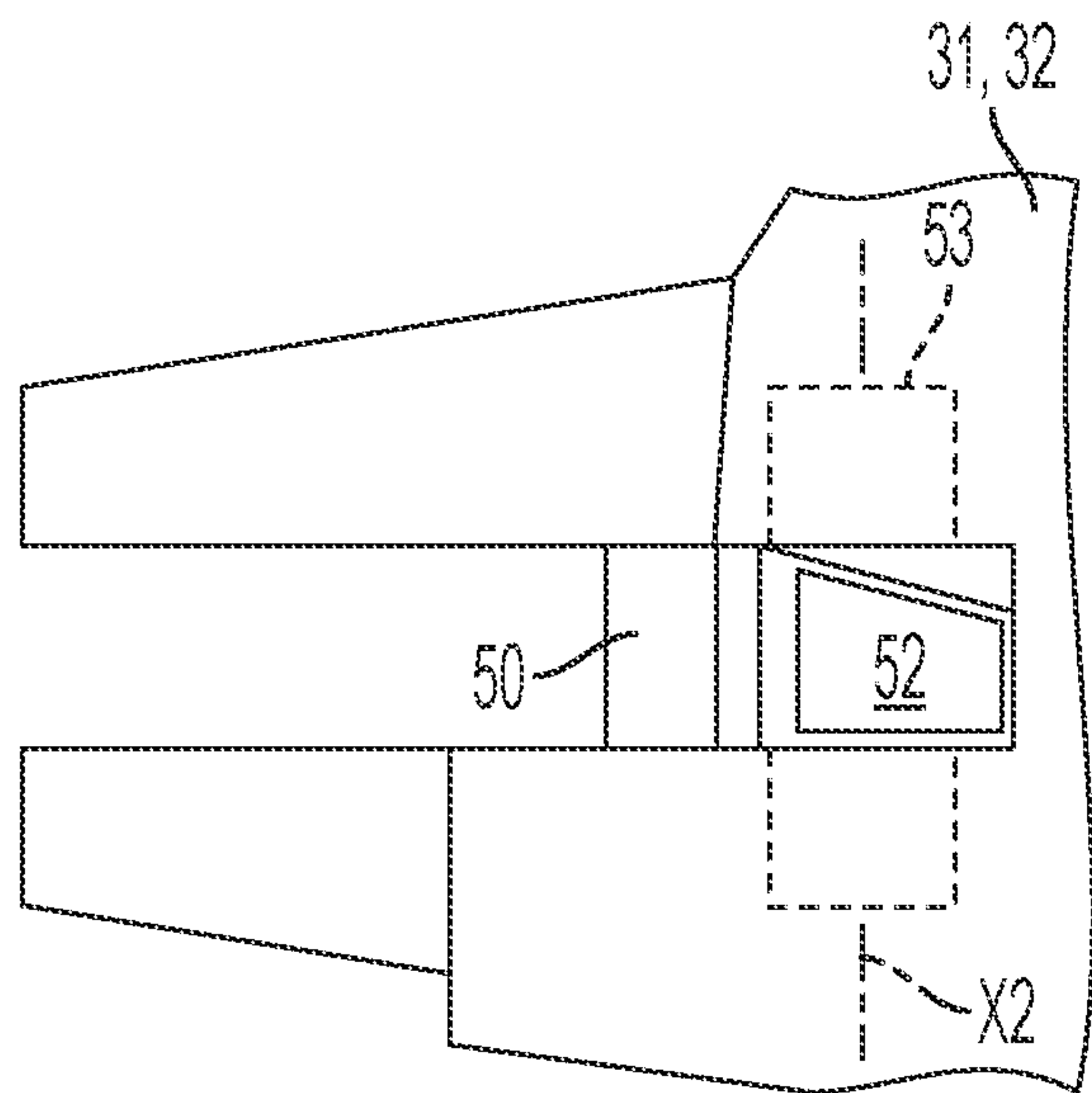

FIG. 7

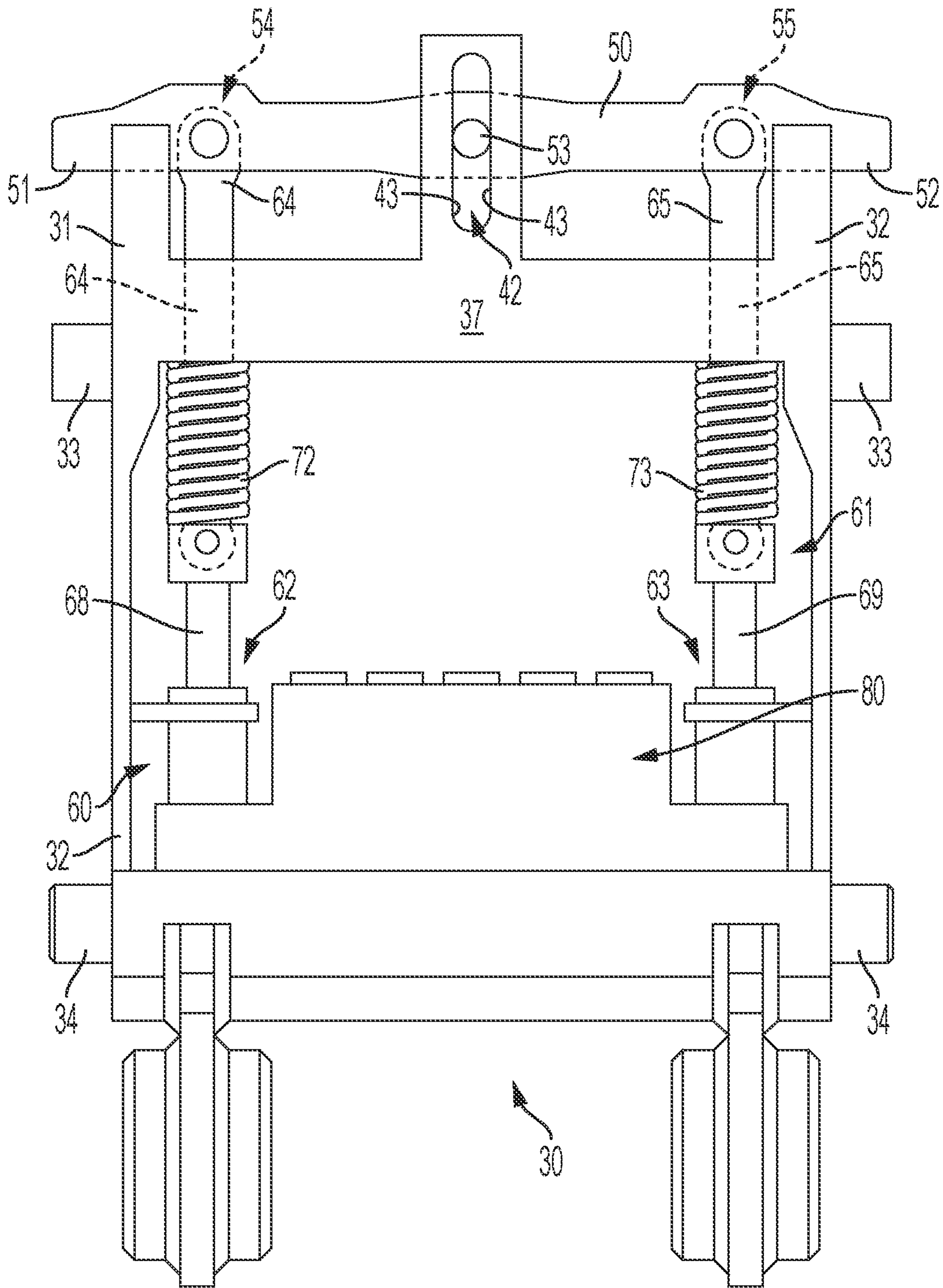

FIG. 8

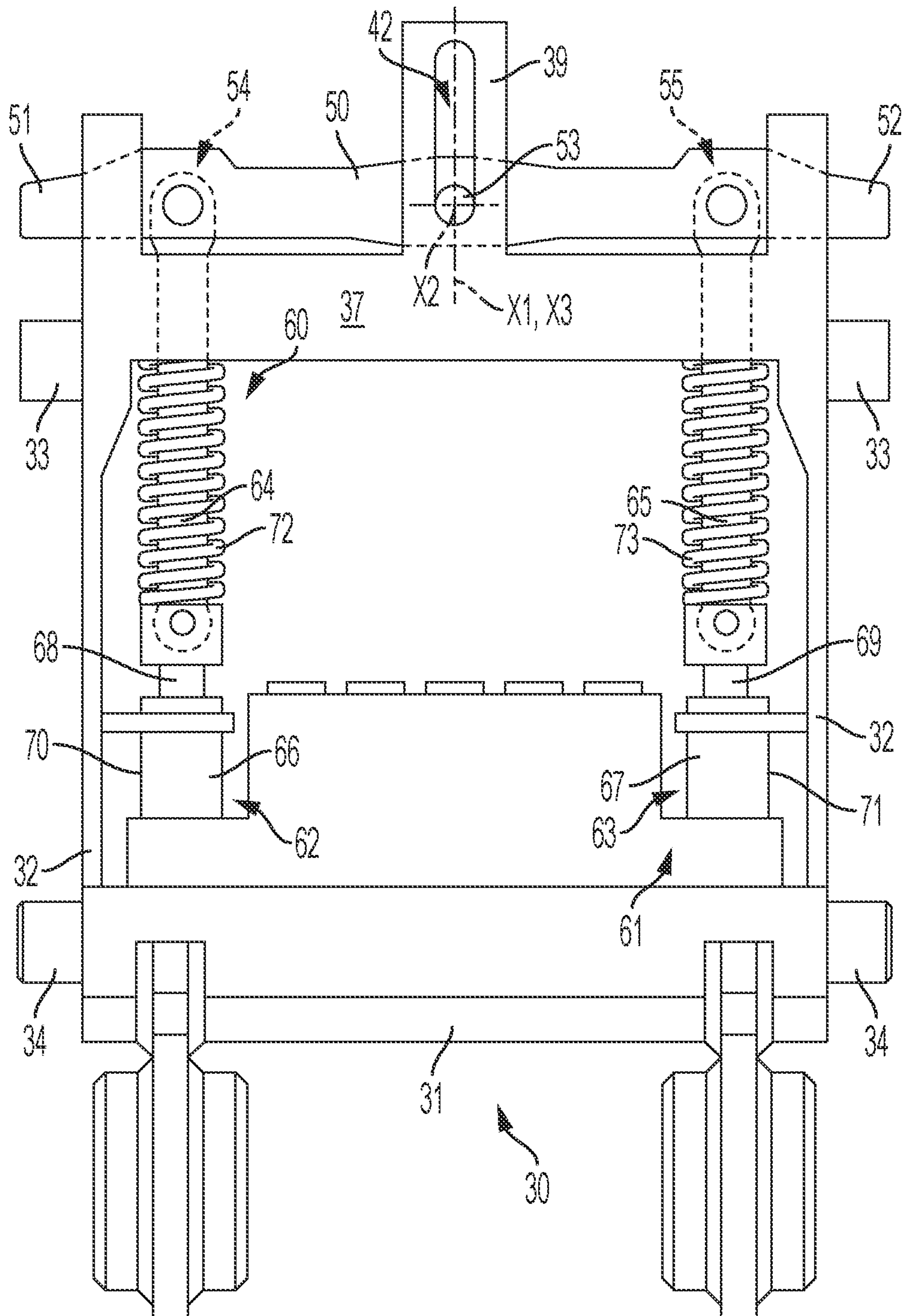

FIG. 9

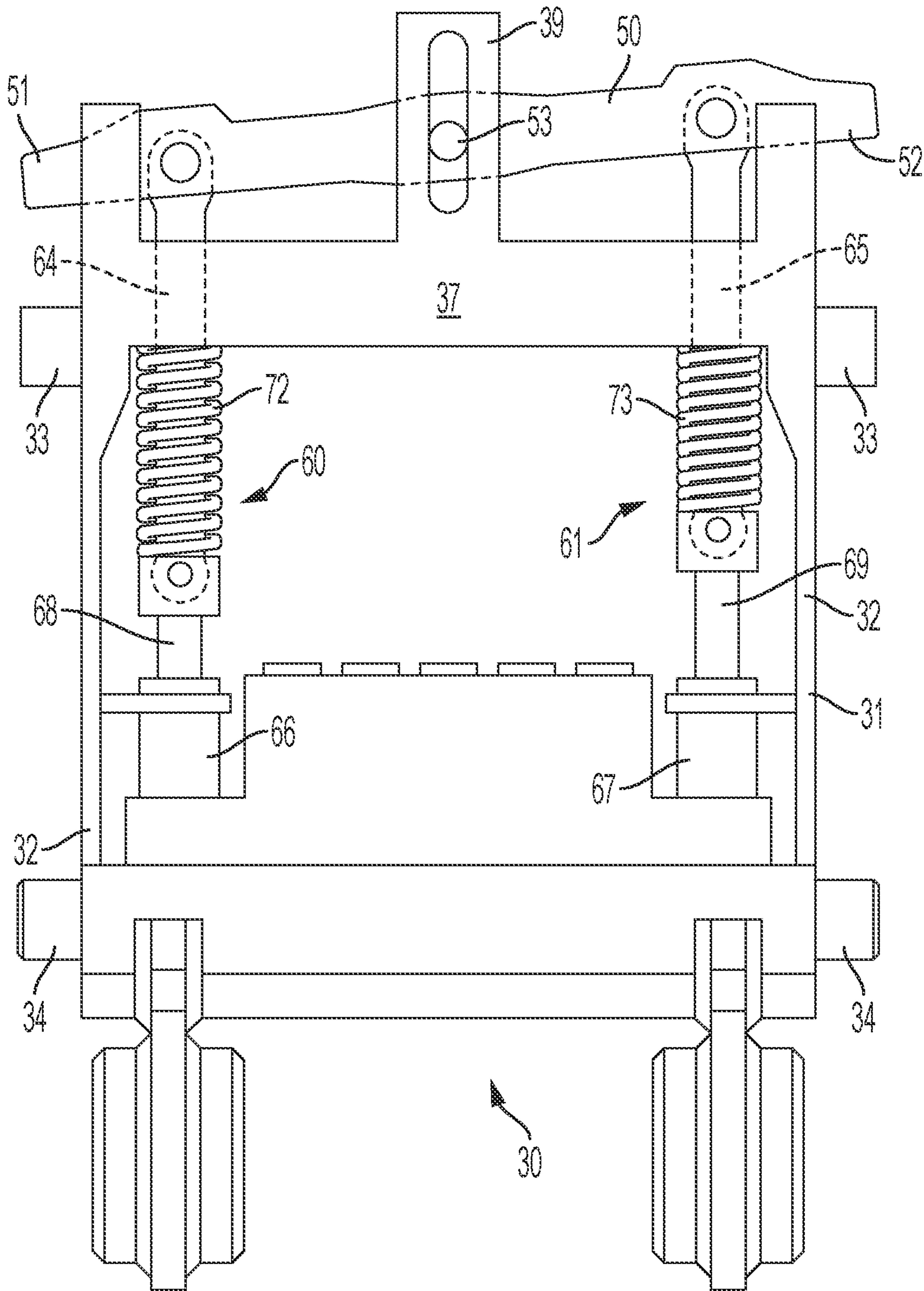

FIG. 10

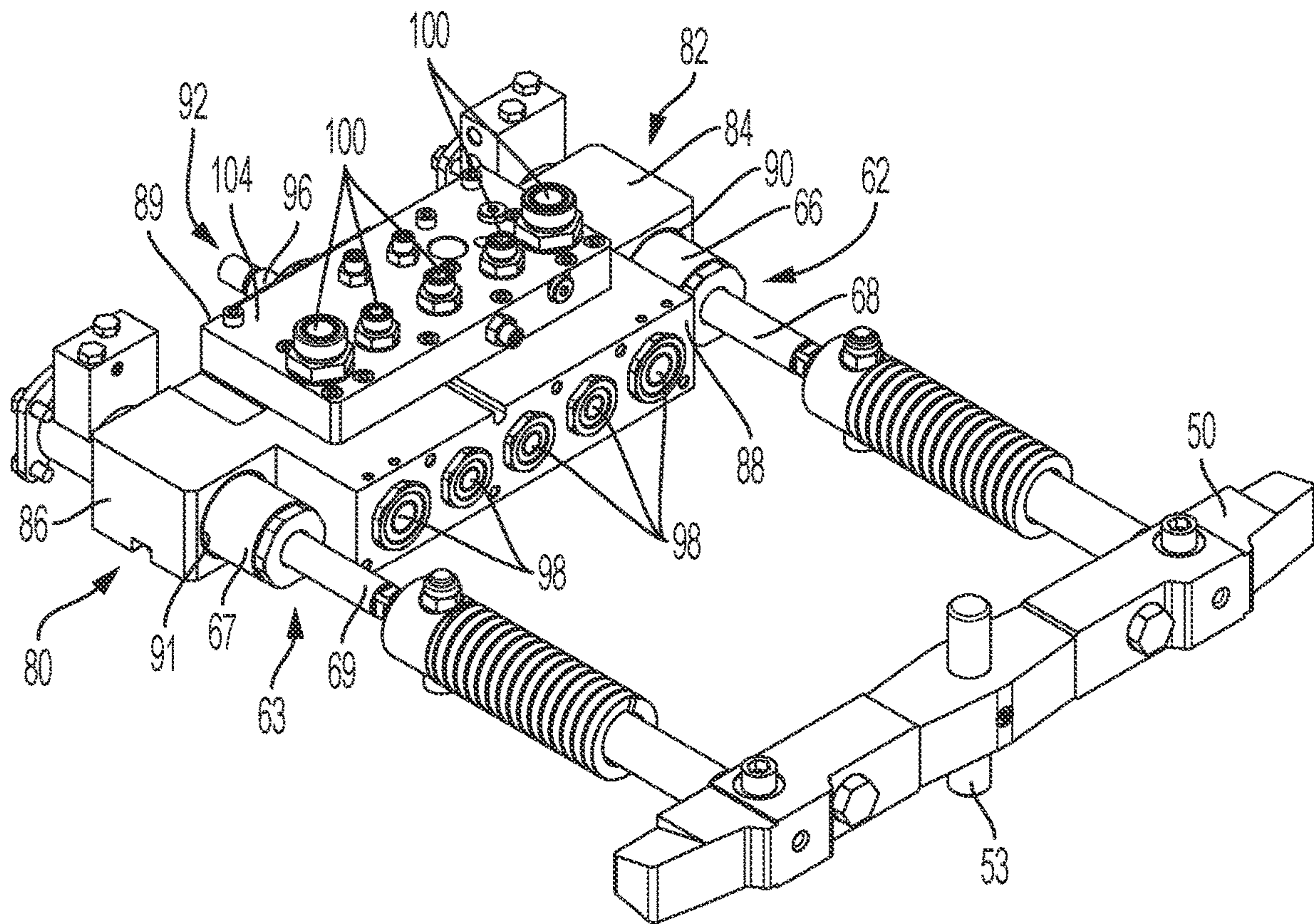

FIG. 11

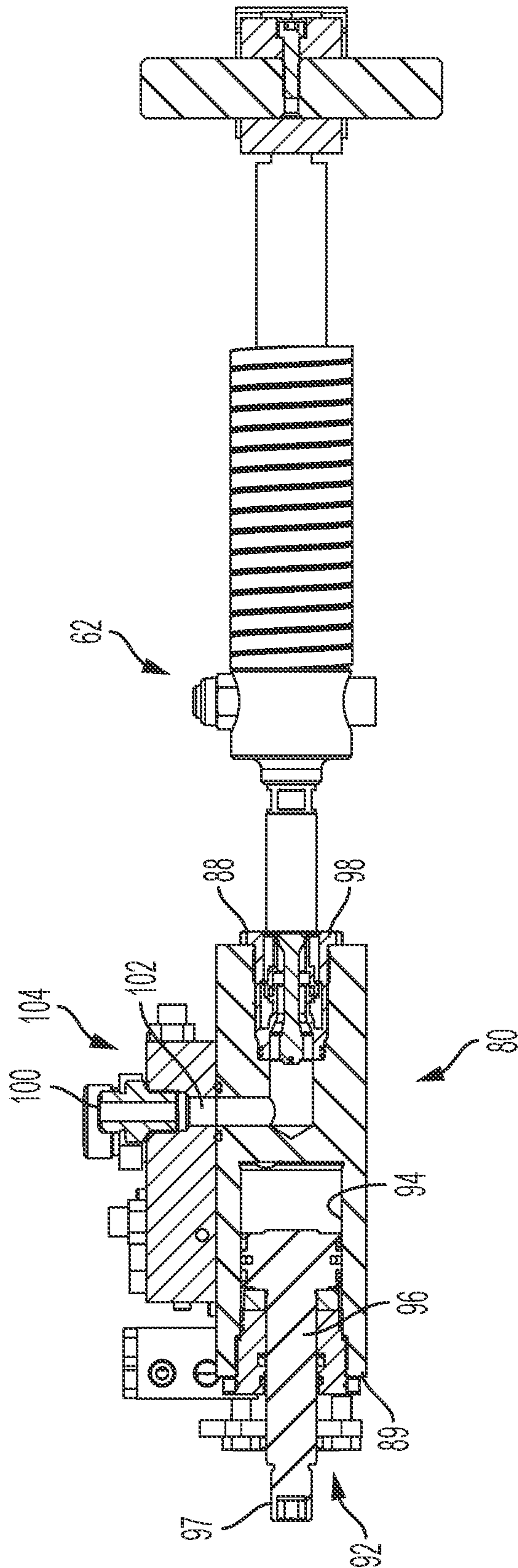

FIG. 12

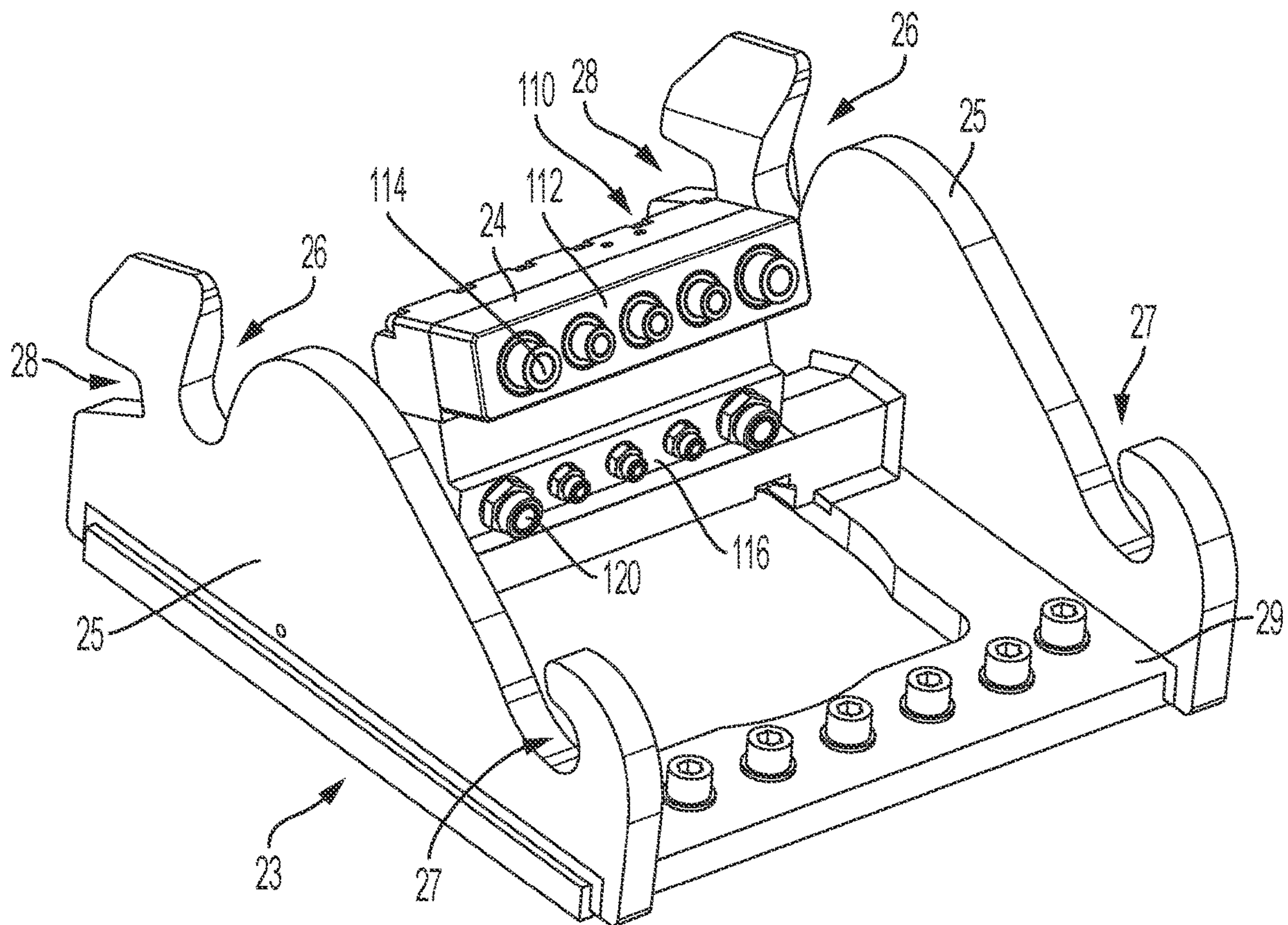

FIG. 13

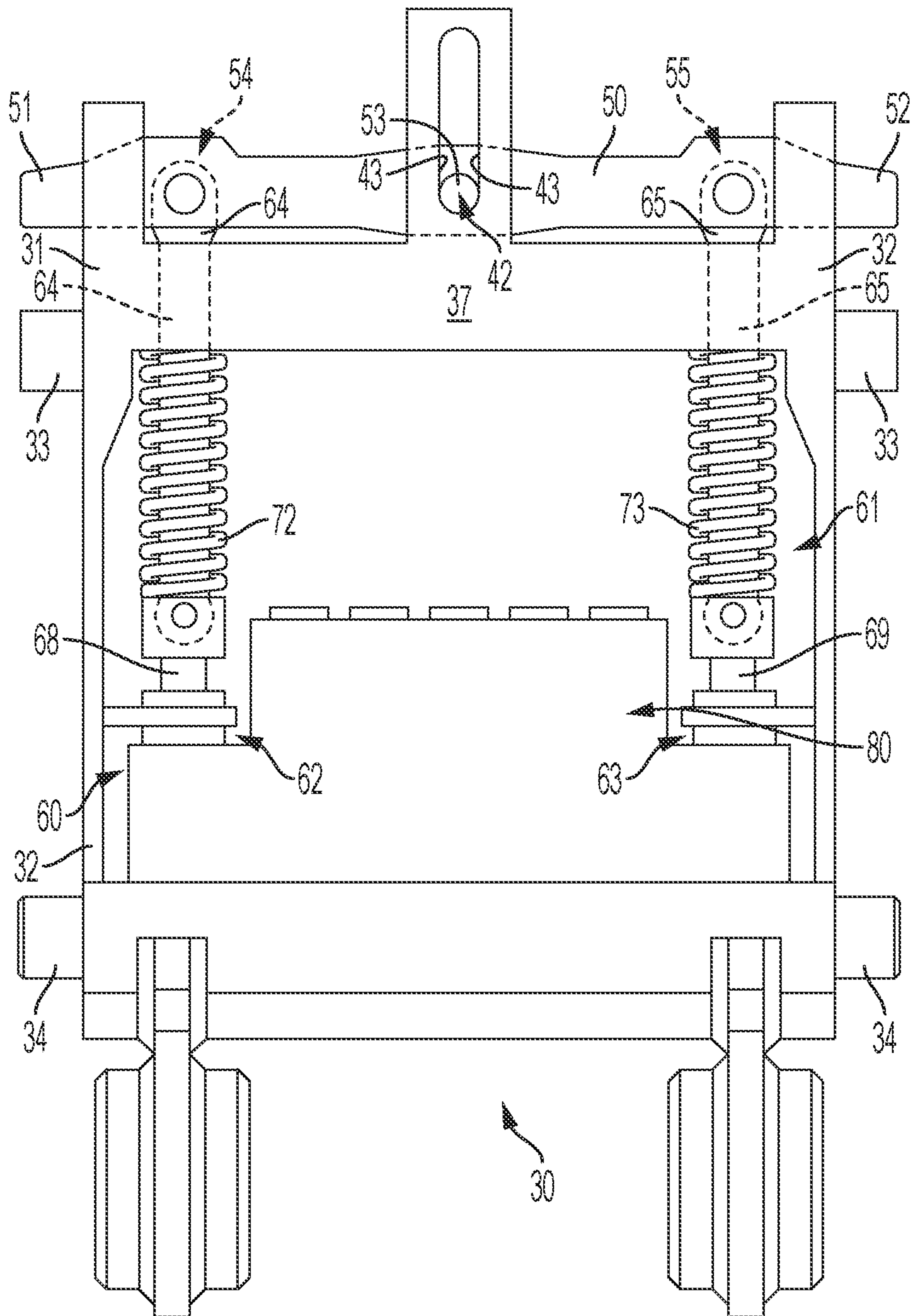

FIG. 14

1

QUICK COUPLER WITH HYDRAULIC COUPLING MANIFOLD

TECHNICAL FIELD

This disclosure relates to coupling assembly, commonly referred to as quick coupler, for attaching a tool to a machine, and in particular to a coupling assembly having a hydraulic manifold for hydraulically coupling the work tool to the machine.

BACKGROUND

Wheeled or tracked machines such as excavators and backhoe loaders are commonly configured to operate a variety of interchangeable tools such as buckets, grabs, breakers, compactors and the like. Each tool is releasably mounted on a rigid mount attached to the machine so as to transmit forces between the tool and the machine in use. The mount forms part of a coupling assembly, commonly referred to as a quick coupler because it makes it easy to connect and disconnect the tool. The quick coupler includes a rigid retaining body movable by one or more actuators, typically hydraulic actuators, between a release position and a retaining position in which the tool is engaged by retaining portions of the retaining body to retain it in fixed relation to the mount. Some work tools include hydraulic actuators used to actuate the work tool. Hydraulic lines from the machine are connected to the work tool so that the hydraulic system on the machine may power the actuators. Some quick coupling systems may include hydraulic connections for connecting the hydraulic system on the machine to the work tool.

For example, U.S. Pat. No. 7,735,249, entitled "Quick-change device," discloses a quick coupler fastened on the machine, an adapter which can be locked with the quick coupler and is connected to the tool, and a hydraulic coupling for producing a hydraulic connection between the hydraulic system on the machine and the hydraulics of the tool. The hydraulic coupling includes a first coupling part and a second coupling part mounted on the front of the quick coupler and adapter, respectively. The two coupling parts are held frictionally in the operating position, relative to one another, by the mechanical retaining means.

SUMMARY

In accordance with the present disclosure there is provided a coupling assembly for releasably mounting a tool on a work machine.

In accordance with one aspect of the present disclosure, a coupling assembly for releasably mounting, and hydraulically coupling, a tool to a work machine includes a mount attachable to the work machine and configured to receive the tool in a mounted position of the tool, a rigid retaining body movable in translation relative to the mount along a translation axis between a retaining position for retaining the tool to the mount and a release position for releasing the tool from the mount, a first and a second actuator operable to move the retaining body between the retaining and release positions, a hydraulic coupling manifold movable in translation relative to the mount along the translation axis for hydraulically coupling the tool to the machine, wherein the hydraulic coupling manifold uses the first and second actuators as guides for moving along the translation axis.

In accordance with another aspect of the present disclosure, a coupling arrangement for releasably mounting, and

2

hydraulically coupling, a tool to a work machine includes a coupling assembly and a hydraulic power transmission coupling attachable to the tool. The coupling assembly includes a mount attachable to the work machine and configured to receive the tool in a mounted position of the tool, a rigid retaining body movable in translation relative to the mount along a translation axis between a retaining position for retaining the tool to the mount and a release position for releasing the tool from the mount, a first and a second actuator operable to move the retaining body between the retaining and release positions, a hydraulic coupling manifold movable in translation relative to the mount along the translation axis for hydraulically coupling the tool to the machine, wherein the hydraulic coupling manifold uses the first and second actuators as guides for moving along the translation axis and is configured to couple to the hydraulic power transmission.

In accordance with another aspect of the present disclosure, a tool bracket, attachable to a work tool, for releasably mounting the work tool to a machine, may include two parallel side plates, each of the side plates defining a front recess for receiving a front lug of a tool coupler, a rear recess for receiving a rear lug of the tool coupler, and a wedge receptacle for receiving a wedge of the tool coupler. The tool bracket further may include a hydraulic power transmission coupling fixably attached to the tool bracket between the two parallel side plates, the hydraulic power transmission coupling including one or more rearward-facing, hydraulic quick connectors configured to hydraulically couple the work tool to the machine.

BRIEF DESCRIPTION OF THE DRAWINGS

Further features and advantages will be evident from the following illustrative embodiment which will now be described, purely by way of example and without limitation to the scope of the claims, and with reference to the accompanying drawings, in which:

FIG. 1 is side view of a work machine having a coupling assembly and a tool detached from the coupling assembly;

FIG. 2 is a side view of the tool;

FIG. 3 is a side view of the tool received in the mounted position on the coupling assembly with a retaining body of the coupling assembly in the release position;

FIG. 4 is a side view of the tool of received in the mounted position on the coupling assembly with a retaining body of the coupling assembly in the retaining position;

FIG. 5 is a side view of the coupling assembly with the retaining body in the release position;

FIG. 6 is an enlarged partial side view of the coupling assembly, showing the retaining body in the release position;

FIG. 7 is an enlarged partial side view of the coupling assembly, showing the retaining body in the retaining position;

FIG. 8 is a bottom view of the coupling assembly showing the retaining body in the release position; and

FIG. 9 is a bottom view of the coupling assembly showing the retaining body in the retaining position;

FIG. 10 is a bottom view of the coupling assembly showing the retaining body in a rotated position;

FIG. 11 is a partial perspective view of the coupling assembly;

FIG. 12 is a side section view of the coupling assembly of FIG. 11;

FIG. 13 is a perspective view of a bracket and hydraulic power transmission of the tool; and

3

FIG. 14 is a bottom view of the coupling assembly showing the hydraulic coupling manifold in an extended position.

DETAILED DESCRIPTION

In this specification, a work machine means any machine, such as a fixed or mobile machine, which is configured to manipulate and operate a tool mounted on the machine. The machine may perform some type of operation associated with an industry such as mining, construction, farming, transportation, or any other industry known in the art. For example, the work machine 1 may be an earth moving machine such as an excavator (shown in FIG. 1), a backhoe, a loader, material handler, or any other earth moving machine.

Referring to FIG. 1, an illustrated embodiment of a coupling assembly 30 includes a rigid mount 31 pivotably attached to a distal end of an arm or stick 2 of a work machine 1. In the illustrated embodiment, the work machine 1 is configured as a tracked excavator having a machine body or house 4 rotatably mounted on tracks 5 and containing a seat 6 for the operator. The stick 2 is pivotably mounted at the distal end of another arm or boom 3 which in turn is pivotably mounted on the body 4. One or more actuators 7 are arranged to move the stick 2, the boom 3, and the mount 31 by hydraulic pressure from a source such as an engine driven hydraulic pump 8 responsive to commands received from the operator via one or more user controls 9, such as for example, a joystick.

Referring to FIGS. 2-3, an illustrated embodiment of a tool 20 is configured as a grab with arms 21. In other embodiments, however, the tool 20 may be any hydraulically-actuable tool. The arms 21 are actuable by hydraulic actuators 22 on the tool 20 responsive to hydraulic pressure which is transmitted from the hydraulic pump 8 to the tool 20 via a hydraulic power transmission coupling 24, described in more detail below. The tool 20 may include a tool bracket 23 configured to be releasably mounted to the coupling assembly 30. The tool bracket 23 may be integrally formed with the tool 20 or attached to the tool 20 by any suitable means, such as for example, welding or fasteners. The tool bracket 23 may include the hydraulic power transmission coupling 24 and structure to releasably mount to the coupling assembly 20 to form a coupling arrangement. In the illustrated embodiment, the tool bracket 23 includes two parallel side plates 25 (one of which has been removed in FIG. 2 to show the hydraulic power transmission coupling 24, the other being a mirror image) and a base 29 extending between the side plates 25. In the illustrated embodiment, the base 29 is extends perpendicular to the side plates 25. In other embodiments, however, the base 29 may not extend perpendicular to the side plates 25. Each of the side plates 25 define a front recess 26, a rear recess 27, and a wedge receptacle 28.

Referring to FIGS. 5 and 9, the mount 31 may be configured as a rigid steel casting or fabrication having parallel side plates 32 connected by a central portion 37 and supporting outwardly and oppositely projecting front lugs 33 and rear lugs 34. At the forward end of the mount 31, each side plate 32 may define an upper guide surfaces 35 and an opposed, spaced-apart, lower guide surface 36 (FIG. 6).

The central portion 37 of the mount 31 includes a first portion 38 and an opposed second portion 39 that extend from a forward end 47 of the mount 31 along a longitudinal central axis X1 mid-way between the side plates 32 to define a second upper guide surface 40 and an opposed, spaced-

4

apart, second lower guide surfaces 41 (FIG. 6). The coupling assembly 30 may include a pair of slots 42, one in each of the first portion 38 and the opposed second portion 39, to extend along the longitudinal central axis X1 and open through the respective one of the second upper and lower guide surfaces 40, 41. The opposed walls of each slot 42 may be exactly superposed in plan view and may define another pair of opposed third guide surfaces 43 which extend in spaced relation in parallel with the central longitudinal axis X1 (FIG. 8).

Each side plate 32 may also define a front mounting hole 44 and a rear mounting hole 45 through which front and rear pins 10 are inserted to attach the mount 31 to the stick 2 of the work machine 1. The coupling assembly 30 includes a rigid retaining body 50 for attaching the coupling assembly 30 to the tool 20. The mount 31 may be configured as a housing in which the rigid retaining body 50 is arranged to be movable relative to the mount 31 between a retaining position as shown in FIGS. 4, 7 and 9 and a release position as shown in FIGS. 3, 5, 6 and 8.

The retaining body 50 may be configured in a variety of ways. In the illustrated embodiment, the retaining body 50 is configured as an elongate solid bar, with its opposite end regions defining a first retaining portion 51 and a second retaining portion 52. In use, the first retaining portion 51 and the second retaining portion 52 may directly engage the tool bracket 23 and may extend outwardly of the side plates 32 on each side of the mount 31 as shown in FIG. 8.

The first retaining portion 51 and a second retaining portion 52 may be slidably received between the upper guide surface 35 and the lower guide surfaces 36 (FIG. 6). When considered in end view, as best seen in FIGS. 6-7, each of the first retaining portion 51 and the second retaining portion 52 may be shaped to form a wedge which may taper towards the rear end of the mount 31.

Referring to FIGS. 1, 3 and 4, the tool 20 may be releasably mounted on the work machine 1 by manipulating the boom 3, the stick 2 and the mount 31 to position the mount 31 over the tool bracket 23 so that the rear lugs 34 are received in the rear recesses 27. Then, the mount 31 may be pivoted so that the front lugs 33 are received in the front recesses 26, whereby the tool 20 is received on the mount 31 in the mounted position as shown in FIG. 3. With the tool 20 in the mounted position, the retaining body 50 is then moved by a first actuator assembly 60 and a second actuator assembly 61, as further described below, from the release position as shown in FIG. 3 to the retaining position as shown in FIG. 4.

The first retaining portion 51 and the second retaining portion 52 are configured, in the retaining position of the retaining body 50, to retain the tool in the mounted position, and in the release position of the retaining body, to release the tool from the mounted position. The first retaining portion 51 and the second retaining portion 52 may engage fittingly, each in a respective one of the wedge receptacles 28 of the tool bracket 23 to prevent the tool bracket 23 from rotating relative to the mount 31. Thus, in combination with the front lugs 33, the rear lugs 34, and other contact surfaces, the first retaining portion 51 and the second retaining portion 52 retain the tool 20 in the mounted position, as shown in FIG. 4.

The retaining body 50 is pivotably connected to the mount 31 at a pivot axis X2 arranged between the first retaining portion 51 and the second retaining portion 52. The pivot axis X2 may be located mid-way between the first retaining portion 51 and the second retaining portion 52 when considered in the length direction of the retaining body 50.

5

The retaining body **50** is movable in translation relative to the mount **31** along a translation axis **X3** which is acollinear (which is to say, not collinear) with the pivot axis **X2** between the release position and the retaining position, as shown respectively in FIGS. **8** and **9**. The translation axis **X3** may be collinear with the longitudinal central axis **X1** of the mount **31**. The pivot axis **X2** may be normal to the translation axis **X3** and may intersect the translation axis **X3**, as shown.

The retaining body **50** is pivotable about the pivot axis **X2** relative to the mount **31** when the pivot axis **X2** is positioned along the translation axis **X3** anywhere in a range of movement in-between the retaining and release positions, as shown in FIG. **10**. In the retaining position the first retaining portion **51** and the second retaining portion **52** are clamped by the first actuator assembly **60** and the second actuator assembly **61** (to the mount **31** and/or to the tool bracket **23**) so that the retaining body **50** is fixed relative to the mount **31** to retain the tool **20** in the mounted position.

The pivot axis **X2** may be fixed relative to the retaining body **50** and movable in translation relative to the mount **31** along the translation axis **X3** by movement of the retaining body **50** between the retaining and release positions. As shown in the illustrated embodiment, this may be achieved by providing an axle **53**, which may be a solid (optionally, cylindrical) body fixed to the retaining body **50** to extend outwardly from one or, as illustrated, from both of its opposite (upper and lower) sides, so that the central axis of the axle **53** defines the pivot axis **X2**.

In this specification, an "axle" means a shaft or pin, for example, a trunnion or a pair of oppositely directed collinear trunnions, that defines a pivot axis about which the retaining body **50** can rotate at least through a limited angular range. The axle **53** is slidably guided for translation between third guide surfaces **43** defined by slots **42** formed in first portion **38** and the opposed second portion **39** of the mount **31**. The middle region of the retaining body from which the axle **53** extends may be slidably received between the second upper guide surface **40** and the second lower guide surface **41** of the mount **31**, which may be generally normal to the third guide surfaces **43** of the slots **42**.

Thus, the retaining body **50** may both pivot and translate in the same plane while the third guide surfaces **43** constrain its translation at the position of the pivot axis **X2** to one degree of freedom (along the translation axis **X3**) in the plane, and the first upper and lower guide surfaces **35**, **36** and the second upper and lower guide surfaces **40**, **41** prevent the retaining body **50** from moving out of the plane.

The first actuator assembly **60** and the second actuator assembly **61** include a first actuator **62** and a second actuator **63**, respectively. The first actuator **62** and the second actuator **63** are provided for moving the retaining body **50** between the retaining and release positions. The first and second actuator assemblies **60**, **61** and the first and second actuators **62**, **63** may be arranged respectively at first and second sides of the mount **31**, in parallel, as shown in FIGS. **8-10**.

The first actuator assembly **60** is pivotably connected to a first region **54** of the retaining body **50** between the first retaining portion **51** and the pivot axis **X2**, while the second actuator assembly **61** is pivotably connected to a second region **55** of the retaining body **50** between the second retaining portion **52** and the pivot axis **X2**.

As exemplified by the illustrated embodiment, the first and second actuator assemblies **60**, **61** may include, respectively, a first rigid connector **64** and a second rigid connector **65**. The first rigid connector **64** is pivotably connected to the

6

first actuator **62** and pivotably connected to the first region **54** of the retaining body **50**, while the second rigid connector **65** is pivotably connected to the second actuator **63** and pivotably connected to the second region **55** of the retaining body **50**.

The pivot connection at each end of each of the rigid connectors **64**, **65** allows a static part of each of the actuators **62**, **63** to be mounted in fixed relation to the mount **31** while decoupling each of the actuators **62**, **63** from a bending moment resulting from torque applied by external forces acting on the first and second retaining portions **51**, **52**. In alternative embodiments, however, the actuators **62**, **63** may be connected via a differently configured linkage to the retaining body **50**.

In the illustrated embodiment, the first actuator **62** and the second actuator **63** are configured as hydraulic cylinders. In other embodiments, however, the first and second actuators **62**, **63** may be any suitable actuator. The first actuator **62** include a first tube portion **66** and first piston-rod assembly **68** arranged within the first tube portion **66** to form a head-end pressure chamber and a rod-end pressure chamber. Likewise, the second actuator **63** includes a second tube portion **67** and a second piston-rod assembly **69** arranged within the second tube portion **67** to form a head-end pressure chamber and a rod-end pressure chamber. The pressure chambers may be selectively supplied with pressurized fluid and drained of the pressurized fluid to cause the first and second piston-rod assemblies **68**, **69** to displace within the first and second tube portions **66**, **67**, respectively, thereby changing the effective length of actuators **62**, **63**.

The first and second piston-rod assemblies **68**, **69** are pivotably connected, respectively to the first and second regions **54**, **55** of the retaining body **50** via respective, first and second linkages, which may comprise first and second, rigid connectors **64**, **65**, for example as shown, while the first and second tube portions **66**, **67** forming the static parts of the first and second actuators **62**, **63**, respectively, are mounted in fixed relation to the mount **31**.

As shown in FIG. **9**, the first tube portion **66** includes a first cylindrical exterior surface **70** and the second tube portion includes a second cylindrical exterior surface **71**. Each of the first cylindrical exterior surface **70** and the second cylindrical exterior surface **71** are free of, or mostly free of, exterior fittings and hydraulic lines.

The first actuator assembly **60** may include a first resilient bias element **72**, and the second actuator assembly **61** may include a second resilient bias element **73**. The first and second resilient bias elements **72**, **73** may be any suitable bias elements, such as for example, a coil spring. The first and second resilient bias elements **72**, **73** are arranged to urge the first and second retaining portions **51**, **52**, respectively, towards the engaged position of the retaining body **50**.

The forward end of each of the first and second bias element **72**, **73** may bear against the central portion **37** at the forward end of the mount **31** while the rigid connectors **64**, **65** pass through apertures in the central portion **37** of the mount **31** to connect pivotably with the retaining body **50**. Each of the apertures is dimensioned to accommodate the angular displacement of the respective rigid connector **64**, **65** as the retaining body **50** pivots under torque, as shown in FIG. **10**.

As shown in FIGS. **8-11**, the coupling assembly **30** includes a hydraulic coupling manifold **80**. The hydraulic coupling manifold **80** may be configured in a variety of ways. Any hydraulic coupling manifold **80** that can be arranged on the mount **31** between the first and second

7

actuator assemblies **60**, **61** and use the first and second actuator assemblies **60**, **61** as a guide for hydraulically coupling to the hydraulic power transmission coupling **24** on the tool **20** may be used. The hydraulic coupling manifold **80** can move between a coupled position, in which the tool **20** is hydraulically coupled to the work machine **1**, and an uncoupled position, in which the tool **20** is hydraulically decoupled from the work machine **1**.

In the illustrated embodiment, the hydraulic coupling manifold **80** has a generally rectangular manifold body **82** that extends between the first and second actuator assemblies **60**, **61**. In other embodiments, however, the manifold body **82** can be any suitable size and shape. In the illustrated embodiment, the manifold body **82** includes a first end portion **84**, a second end portion **86** opposite the first end portion **84**, a front face **88** extended between the first end portion **84** and second end portion **86** and facing the retaining body **50**, and a rear face **89**, opposite the front face **88** and extended between the first end portion **84** and second end portion **86**.

The hydraulic coupling manifold **80** is configured to be movable in translation relative to the mount in the direction of the translation axis X3. In the illustrated embodiment, the hydraulic coupling manifold **80** moves in the same plane as the retaining body **50**. In other embodiments, the hydraulic coupling manifold **80** may not move coplanar with the retaining body **50**. The hydraulic coupling manifold **80** uses the first and second actuator assemblies **60**, **61** as a guide for movement between the coupled position (FIG. 14) and an uncoupled position (FIG. 8). The coupled position refers to the position in which the hydraulic coupling manifold is hydraulically coupled to the hydraulic power transmission coupling **24**. The decoupled position refers to the position in which the hydraulic coupling manifold is not coupled to the hydraulic power transmission coupling **24**. In some embodiments, the decoupled position refers to a fully retracted position of the hydraulic coupling manifold. The hydraulic coupling manifold **80** can be configured to use the first and second actuator assemblies **60**, **61** as a guide in a variety of ways.

In the illustrated embodiment, the first end portion **84** includes a first passage **90** configured to receive the first actuator **62** and the second end portion **86** includes a second passage **91** configured to receive the second actuator **63**. In the illustrated embodiment, the first passage **90** circumferentially surrounds the first exterior surface **70** of the first actuator **62** and the second passage **91** circumferentially surrounds the second exterior surface **71** of the second actuator **63**. In other exemplary embodiments, the first and second passages **90**, **91** may only partially surround the first exterior surface **70** and the second exterior surface **71**, respectively.

The hydraulic coupling manifold **80** may include a friction-reducing interface between the first exterior surface **70** of the first actuator **62** and the first passage **90** and a friction-reducing interface between the second exterior surface **71** of the second actuator **63** and the second passage **91**. Any suitable friction-reducing interface may be used, such as a lubricated bushing, a roller bearing, or other friction-reducing interface. In one embodiment, the friction-reducing interface is a grease bushing (not shown) and the hydraulic coupling manifold **80** may include one or more grease zerks for supplying grease to the bushings.

As shown in FIG. 12, the coupling assembly **30** includes a third actuator **92** associated with the hydraulic coupling manifold **80**. The third actuator **92** is configured to move the hydraulic coupling manifold **80** between the coupled and

8

uncoupled positions. The third actuator **92** may be configured in a variety of ways. Any suitable actuator may be used. In the illustrated embodiment, the third actuator **92** is a hydraulic cylinder.

The third actuator **92** may be formed integrally with the manifold body **82**, as shown in FIG. 12, or may be separate from the manifold body **82**. In the illustrated embodiment, the manifold body **82** forms a cylindrical cavity **94** and a third piston-rod assembly **96** is arranged within the cylindrical cavity **94** to form a head-end pressure chamber and a rod-end pressure chamber. The third piston-rod assembly **96** includes a distal end **97** that extends outward of the rear face **89** of the manifold body **82** and is fixably attached to fixed surface (not shown), such as a portion of the rigid mount **31** or a surface attached to the rigid mount **31**. The distal end **97** may be fixably attached in any suitable manner, such as for example, a threaded connection.

Selectively supplying one of the pressure chambers with pressurized fluid and draining pressurized fluid from the other chamber causes the third piston-rod assembly **96** to displace within the cylindrical cavity **94** thereby changing the effective length of third actuator **92**. Since the distal end **97** is fixed relative to the rigid mount **31**, supplying the head-end pressure chamber with pressurized fluid while draining pressurized fluid from rod-end pressure chamber, moves the hydraulic coupling manifold **80** toward the retaining body **50** and the hydraulic power transmission coupling **24**. Likewise, supplying the rod-end pressure chamber with pressurized fluid while draining pressurized fluid from head-end pressure chamber, moves the hydraulic coupling manifold **80** away the retaining body **50** and the hydraulic power transmission coupling **24**.

The hydraulic coupling manifold **80** includes one or more hydraulic quick connectors **98**. The one or more hydraulic quick connectors **98** may be configured in a variety of ways. For example, any suitable type, number, size, orientation, and arrangement of the one or more hydraulic quick connector **98** may be used. In the illustrated embodiment, the hydraulic coupling manifold **80** includes five, female hydraulic quick connectors **98** arranged horizontally in-line across the front face **88** of the manifold body **82**. In other embodiments, the hydraulic coupling manifold **80** may include more or less than five hydraulic quick connectors **98**, the hydraulic quick connectors **98** may be male connectors, and/or the hydraulic quick connectors **98** may be arranged other than horizontally in-line.

The hydraulic coupling manifold **80** includes hydraulic fluid inlets **100** and flow passages **102** connecting the hydraulic fluid inlets **100** to the hydraulic quick connectors **98**. The hydraulic fluid inlets **100** are in fluid communication with the hydraulic pump **8** to supply hydraulic fluid through the hydraulic quick connectors **98**. In the illustrated embodiment, hydraulic fluid inlets **100** are located on a top side **104** of the manifold block and the flow passages **102** are formed, generally, as 90-degree elbows. In other embodiments, however, the hydraulic fluid inlets **100** may be positioned at any suitable location on the hydraulic coupling manifold **80** and the flow passages **102** may be configured in any suitable manner to fluidly connect the hydraulic fluid inlets **100** to the hydraulic quick connectors **98**.

Referring to FIGS. 2 and 12, the hydraulic power transmission coupling **24** on the tool **20** is configured and positioned to couple to the hydraulic coupling manifold **80**. The hydraulic power transmission coupling **24** may be configured in a variety of ways. Any configuration that can hydraulically couple to a corresponding hydraulic coupling manifold **80** associated with the coupling assembly **30** may

be used. In the illustrated embodiment, the hydraulic power transmission coupling **24** is fixably mounted onto the tool bracket **23** at an angle α that is aligned with the translation axis **X3** of the coupling assembly **30** when the coupling assembly **30** is attached to the tool **20**, as shown by line A in FIG. 2. In the illustrated embodiment, the angle α may be in the range of 10 degrees to 30 degrees relative to the base **29**, such as for example, 15 degrees to 25 degrees, or about 20 degrees.

The hydraulic power transmission coupling **24** includes a transmission body **110** including an upper rear face **112** and one or more hydraulic quick connectors **114** positioned on the upper rear face **112**. The one or more hydraulic quick connectors **114** are configured to couple to the one or more hydraulic quick connectors **98** on the hydraulic coupling manifold **80**. Therefore, the while one or more hydraulic quick connectors **114** may be configured in a variety of ways, such as for example, any suitable type, number, size, orientation, and arrangement of the one or more hydraulic quick connector **114**, the one or more hydraulic quick connectors **114** must be complementary to the one or more hydraulic quick connectors **98** on the hydraulic coupling manifold **80**. In the illustrated embodiment, the hydraulic power transmission coupling **24** includes five, male hydraulic quick connectors **114** arranged horizontally in-line across the upper rear face **112** of the transmission body **110** to connect to the corresponding five, female hydraulic quick connectors **98** on the hydraulic coupling manifold **80**.

The hydraulic power transmission coupling **24** includes a lower rear face **116** and a plurality of hydraulic fluid outlets **120** located on the lower rear face **116**. Flow passages (not shown) fluidly connect the hydraulic quick connectors **114** to the hydraulic fluid outlets **120** to route hydraulic fluid received by to the hydraulic quick connectors **114** to the hydraulic fluid outlets **120**. In the illustrated embodiment, the hydraulic power transmission coupling **24** includes five horizontally in-line hydraulic fluid outlets **120** on the lower rear face **116**, one for each corresponding male hydraulic quick connector **114**.

In alternative embodiments, the various actuators may be either electrically or hydraulically operated. The mount, retaining body, actuator assemblies and other components of the novel coupling assembly may be configured differently to those illustrated. The retaining body may be pivotably connected to the mount either directly or indirectly, for example, via a suitable linkage that guides it in translation.

All of the various hydraulic, electrical or other power supply and control functions may be connected to the hydraulic pump **8** or other hydraulic, electrical or mechanical power supply of the work machine **1** and operated by the operator of the work machine **1** responsive to input via the user controls **9**.

INDUSTRIAL APPLICABILITY

The novel coupling assembly may be used with any suitable work machine and any suitable hydraulically-powered tool. In the illustrated embodiment, by attaching the actuator assemblies to the first and second regions of the retaining body, the actuators can be arranged towards the sides of the mount to provide an open space between them to accommodate the hydraulic coupling manifold. Having the hydraulic coupling manifold positioned in the interior of the coupling assembly between the actuators and the side plates results in the hydraulic coupling manifold being less vulnerable to being damaged during operation than an externally mounted hydraulic coupling arrangement. The

coupling assembly uses the actuators as guides for movement, thus not requiring other guide structure to be included in the coupling assembly. The hydraulic coupling manifold utilizes one or more quick connects for easy and reliable automatic connections when the hydraulic coupling manifold is moved into engagement with the hydraulic power transmission coupling on the tool. The quick connects are arranged horizontally in-line and the hydraulic coupling manifold is actuated by an integrated hydraulic cylinder resulting in a thin profile for the hydraulic coupling manifold that fits conveniently between to actuators and side plates. By using the actuators as guides, the hydraulic coupling manifold moves in the same horizontal plane as the retaining member.

Unless otherwise indicated herein, all sub-embodiments and optional embodiments are respective sub-embodiments and optional embodiments to all embodiments described herein. While the present disclosure has been illustrated by the description of embodiments thereof, and while the embodiments have been described in considerable detail, it is not the intention of the applicant to restrict or in any way limit the scope of the appended claims to such detail. Additional advantages and modifications will readily appear to those skilled in the art. Therefore, the present disclosure, in its broader aspects, is not limited to the specific details, the representative compositions or formulations, and illustrative examples shown and described. Accordingly, departures may be made from such details without departing from the spirit or scope of Applicant's general disclosure herein.

LIST OF ELEMENTS

Element Number	Element Name
1	work machine
2	stick
3	boom
4	house
5	tracks
6	seat
7	actuators
8	hydraulic pump
9	user controls
10	front pins
20	tool
21	arms
22	hydraulic actuators
23	tool bracket
25	side plates
26	front recess
27	rear recess
28	wedge receptacle
29	base
30	coupling assembly
31	rigid mount
32	side plates
33	front lugs
34	rear lugs
35	upper guide surfaces
36	lower guide surface
37	central portion
38	first portion
39	second portion
40	second upper guide surface
41	second lower guide surface
42	slots
43	third guide surfaces
44	front mounting hole
45	rear mounting hole
47	forward end
50	retaining body
51	first retaining portion

11

-continued

LIST OF ELEMENTS	
Element Number	Element Name
52	second retaining portion
53	axle
54	first region
55	second region
60	first actuator assembly
61	second actuator assembly
62	first actuator
63	second actuator
64	first rigid connector
65	second rigid connector
66	first tube portion
67	second tube portion
68	first piston-rod assembly
69	second piston-rod assembly
70	first exterior surface
71	second exterior surface
72	first resilient bias element
73	second resilient bias element
80	hydraulic coupling manifold
82	manifold body
84	first end portion
86	second end portion
88	front face
89	rear face
90	first passage
91	second passage
92	third actuator
94	cylindrical cavity
96	third piston-rod assembly
98	hydraulic quick connectors
100	hydraulic fluid inlets
102	flow passages
110	transmission body
112	upper rear face
114	hydraulic quick connectors
116	lower rear face
120	hydraulic fluid outlets

What is claimed is:

1. A coupling assembly for releasably mounting, and hydraulically coupling, a tool to a work machine, comprising:

a mount attachable to the work machine and configured to receive the tool in a mounted position of the tool;

a rigid retaining body movable in translation relative to the mount along a translation axis between a retaining position for retaining the tool to the mount and a release position for releasing the tool from the mount;

a first and a second actuator operable to move the retaining body between the retaining and release positions; and

a hydraulic coupling manifold movable in translation relative to the mount along the translation axis for hydraulically coupling the tool to the machine,

wherein the first actuator includes a first cylindrical exterior surface, and the second actuator includes a second cylindrical exterior surface; and

wherein the hydraulic coupling manifold moves along the first and second cylindrical exterior surfaces when moving along the translation axis.

2. The coupling assembly of claim 1, further comprising a third actuator associated with the hydraulic coupling manifold to move the hydraulic coupling manifold between a coupled position for hydraulically coupling the tool to the machine and an uncoupled position for hydraulically uncoupling the tool from the machine.

12

3. The coupling assembly of claim 2, wherein the third actuator is mounted within the hydraulic coupling manifold and extends outward in a direction opposite the rigid retaining body.

4. The coupling assembly of claim 2, wherein the manifold assembly is movable between the coupled position and an uncoupled position when the retaining body is in the retaining position.

5. The coupling assembly of claim 1, wherein the hydraulic coupling manifold includes a plurality of quick connect hydraulic couplings for coupling to corresponding hydraulic couplings on the tool.

6. The coupling assembly of claim 1, wherein the hydraulic coupling manifold includes a first passage through which the first actuator extends and a second passage through which the second actuator extends.

7. The coupling assembly of claim 6, wherein the first actuator has a cylindrical exterior surface and the first passage circumferentially surrounds the exterior surface of the first actuator.

8. The coupling assembly of claim 6, wherein the coupling assembly includes a friction-reducing interface between the exterior surface of the first actuator and the first passage.

9. The coupling assembly of claim 8, wherein the friction-reducing interface is one or more grease bushings.

10. The coupling assembly of claim 1, wherein the first actuator extends parallel to the second actuator and the hydraulic coupling manifold extends between the first actuator and the second actuator.

11. The coupling assembly of claim 1, wherein the hydraulic coupling manifold is movable along the translation axis relative to the retaining body.

12. The coupling assembly of claim 1, wherein the retaining body is pivotably connected to the mount at a point on the retaining body between a first end and a second end of the retaining body.

13. A coupling arrangement for releasably mounting, and hydraulically coupling, a tool to a work machine, comprising:

a coupling assembly, comprising:

a mount attachable to the work machine and configured to receive the tool in a mounted position of the tool;

a rigid retaining body movable in translation relative to the mount along a translation axis between a retaining position for retaining the tool to the mount and a release position for releasing the tool from the mount;

first and second actuators operable to move the retaining body in a first direction from the retaining position to the and release position;

a hydraulic coupling manifold movable in translation relative to the mount along the translation axis for hydraulically coupling the tool to the machine, wherein the hydraulic coupling manifold uses the first and second actuators as guides for moving along the translation axis;

a third actuator mounted within the hydraulic coupling manifold and operable to move the hydraulic coupling manifold in a second direction, opposite the first direction, from a coupled position for hydraulically coupling the tool to the machine to an uncoupled position for hydraulically uncoupling the tool from the machine,

a hydraulic power transmission coupling attachable to the tool and configured to couple to the hydraulic coupling manifold.

13

14. The coupling arrangement of claim **13**, wherein the third actuator extends outward in a direction opposite the rigid retaining body.

15. The coupling arrangement of claim **13**, wherein the hydraulic power transmission coupling is mounted on a bracket configured to engage the rigid retaining body in the retaining position.

16. The coupling arrangement of claim **13**, wherein the hydraulic coupling manifold includes one or more quick connect hydraulic couplings and the hydraulic power transmission coupling includes a one or more second quick connect hydraulic couplings, and wherein the hydraulic coupling manifold is movable between a coupled position in which the one or more quick connect hydraulic couplings of hydraulic coupling manifold are fluidly coupled to the one or more second quick connect hydraulic couplings of the hydraulic power transmission coupling and an uncoupled position in which the one or more quick connect hydraulic couplings of hydraulic coupling manifold are not fluidly

14

coupled to the one or more second quick connect hydraulic couplings of the hydraulic power transmission coupling.

17. The coupling arrangement of claim **16**, wherein the one or more quick connect hydraulic couplings of the hydraulic coupling manifold include three or more, linearly arranged, quick connect hydraulic couplings.

18. The coupling arrangement of claim **13**, wherein the hydraulic coupling manifold includes a first passage through which the first actuator extends, wherein the first actuator has a cylindrical exterior surface and the first passage circumferentially surrounds the exterior surface of the first actuator.

19. The coupling arrangement of claim **18**, wherein the hydraulic coupling manifold is movable along the translation axis relative to the exterior surface of the first actuator.

20. The coupling arrangement of claim **13**, wherein the manifold assembly is movable between the coupled position and an uncoupled position when the retaining body is in the retaining position.

* * * * *