

US011428380B2

(12) **United States Patent**  
**Sassoon**

(10) **Patent No.:** **US 11,428,380 B2**  
(45) **Date of Patent:** **Aug. 30, 2022**

(54) **COMBINATION LED LAMPS**

(71) Applicant: **Charles I. Sassoon**, Hauppauge, NY (US)  
(72) Inventor: **Charles I. Sassoon**, Hauppauge, NY (US)  
(\* ) Notice: Subject to any disclaimer, the term of this patent is extended or adjusted under 35 U.S.C. 154(b) by 0 days.

(21) Appl. No.: **17/334,100**

(22) Filed: **May 28, 2021**

(65) **Prior Publication Data**

US 2021/0372587 A1 Dec. 2, 2021

**Related U.S. Application Data**

(60) Provisional application No. 63/031,421, filed on May 28, 2020.

(51) **Int. Cl.**

*F21S 43/14* (2018.01)  
*F21W 103/20* (2018.01)  
*F21W 103/45* (2018.01)  
*F21W 103/35* (2018.01)  
*F21Y 115/10* (2016.01)

(52) **U.S. Cl.**

CPC ..... *F21S 43/14* (2018.01); *F21W 2103/20* (2018.01); *F21W 2103/35* (2018.01); *F21W 2103/45* (2018.01); *F21Y 2115/10* (2016.08)

(58) **Field of Classification Search**

CPC ..... *F21S 43/14*; *F21W 2103/10-45*; *F21Y 2115/10*

See application file for complete search history.

(56) **References Cited**

U.S. PATENT DOCUMENTS

6,520,669 B1 \* 2/2003 Chen ..... F21S 41/143 362/545  
7,683,772 B2 3/2010 Smith  
8,052,313 B2 \* 11/2011 Sassoon ..... B60Q 1/0052 362/545  
9,539,932 B2 \* 1/2017 Fay ..... B60Q 1/34  
2005/0047167 A1 3/2005 Pederson et al.  
2008/0080199 A1 4/2008 Sassoon  
2010/0309677 A1 12/2010 Kazaoka  
2012/0188780 A1 7/2012 Wilk  
2013/0094209 A1 4/2013 Yu  
2013/0201714 A1 8/2013 Huang-Tsai  
2015/0204521 A1 7/2015 Zhang et al.

FOREIGN PATENT DOCUMENTS

EP 1762432 A2 \* 3/2007 ..... B60Q 1/2615

\* cited by examiner

*Primary Examiner* — Jason M Han

(74) *Attorney, Agent, or Firm* — Brown Rudnick LLP; Ian G. DiBernardo

(57) **ABSTRACT**

Various embodiments of a combination lamp are provided, which combine a plurality of different lamp functions in a unitary configuration, and can reduce the total amount of space taken up for at least substantially the same amount of illumination produced. The combination lamps can be configured for use on vehicles, light fixtures, free standing lamps, decorative articles, etc. In some embodiments, each lamp component may have a power connection element independent from the other lamp components.

**10 Claims, 29 Drawing Sheets**

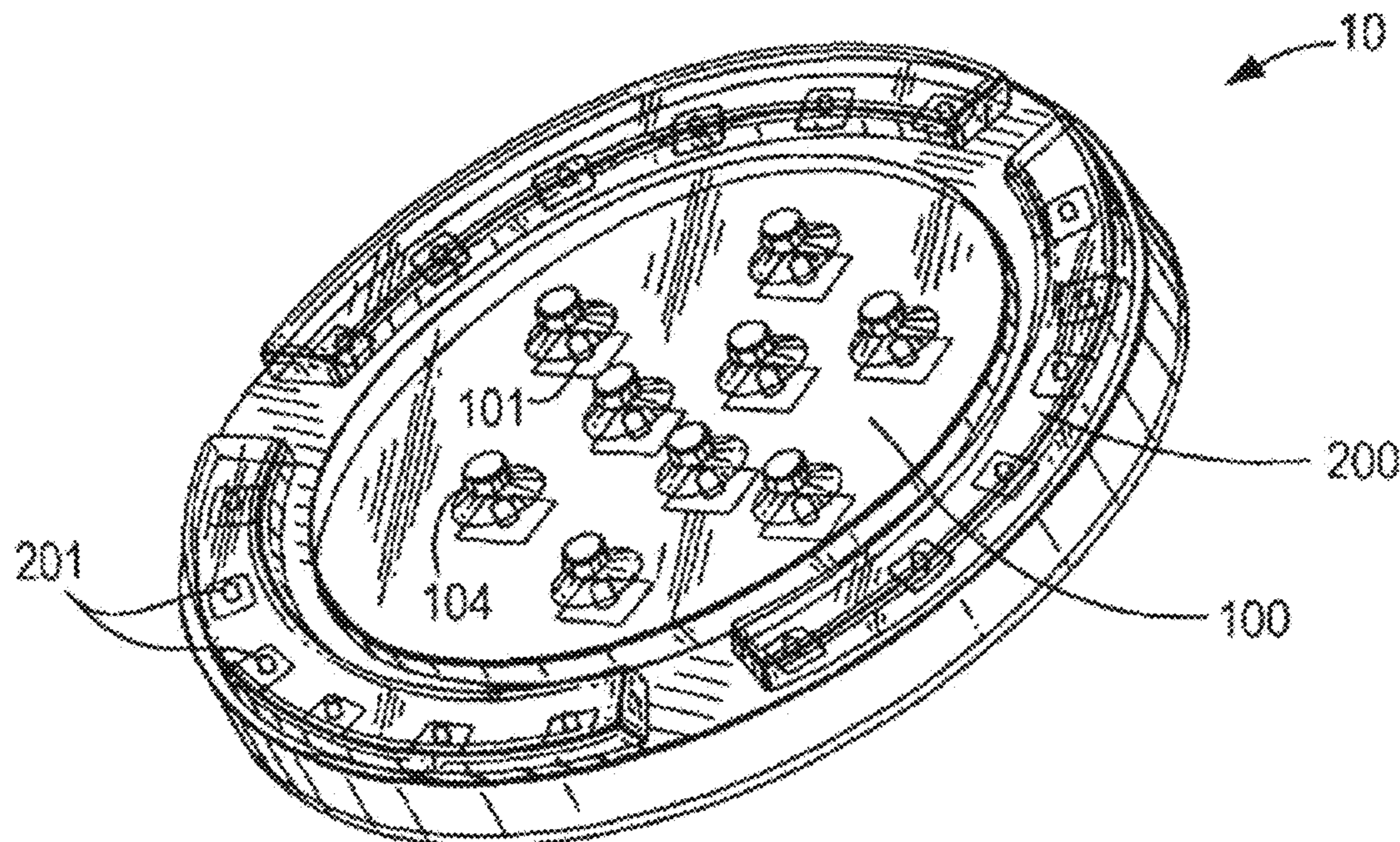

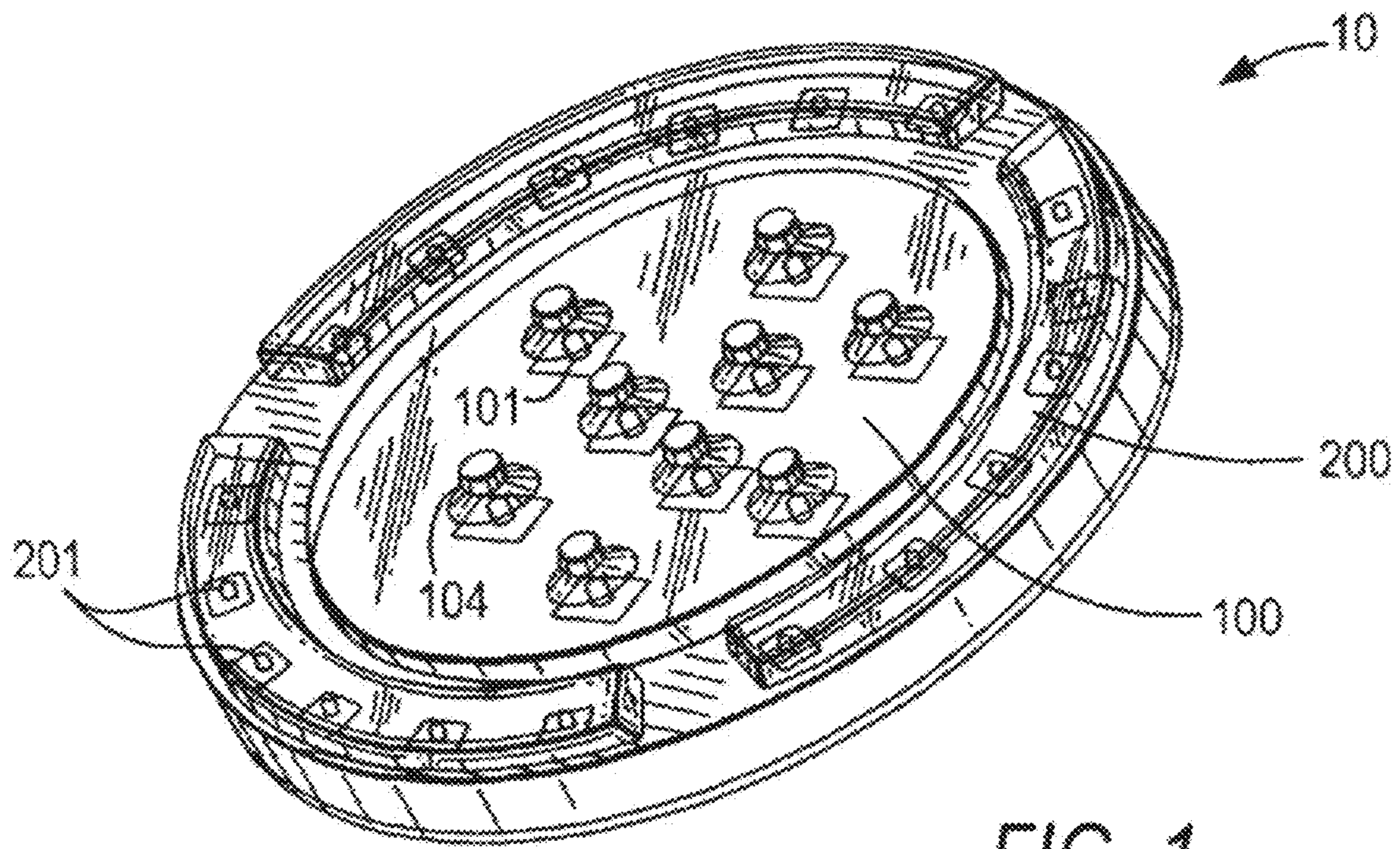

FIG. 1

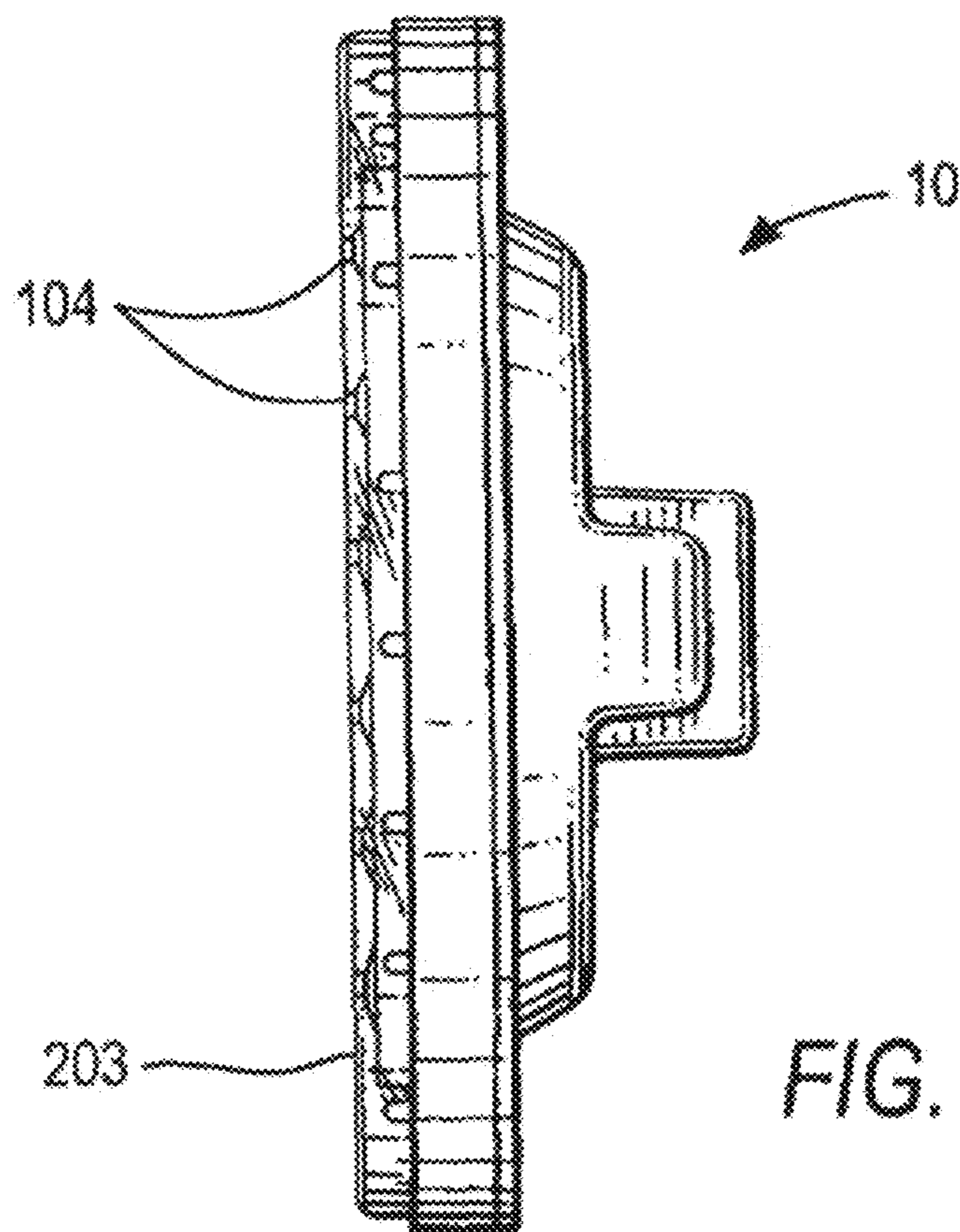

FIG. 3

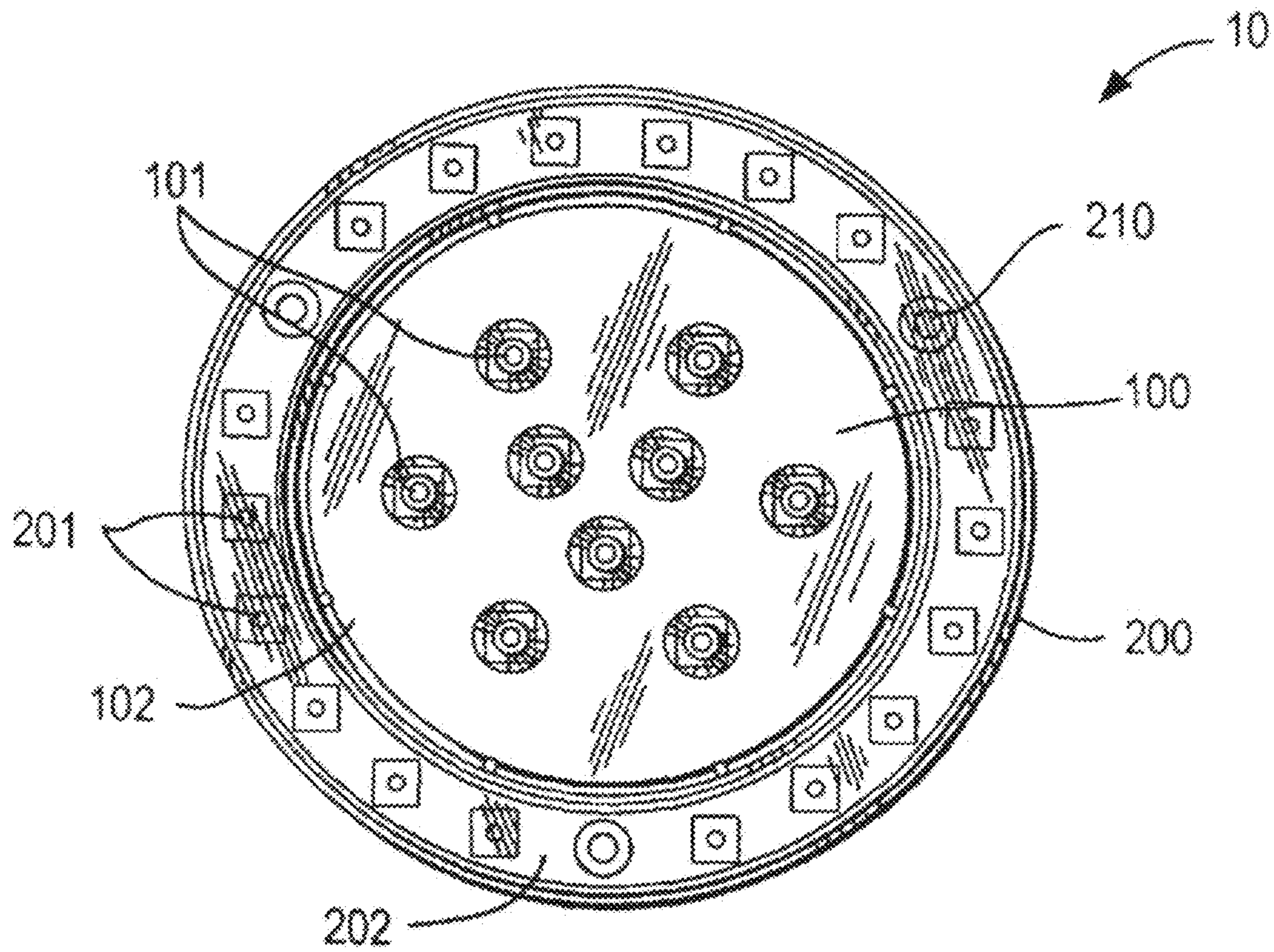

FIG. 2

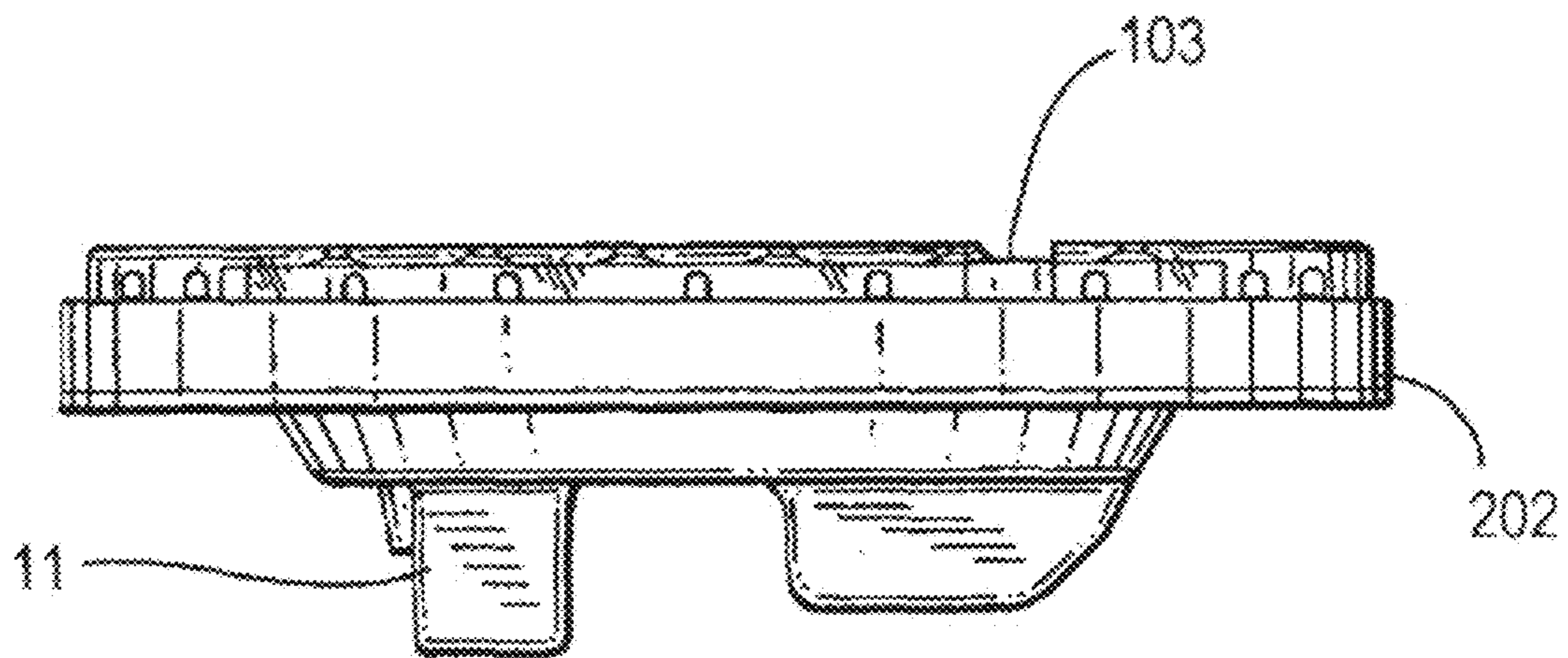

FIG. 4

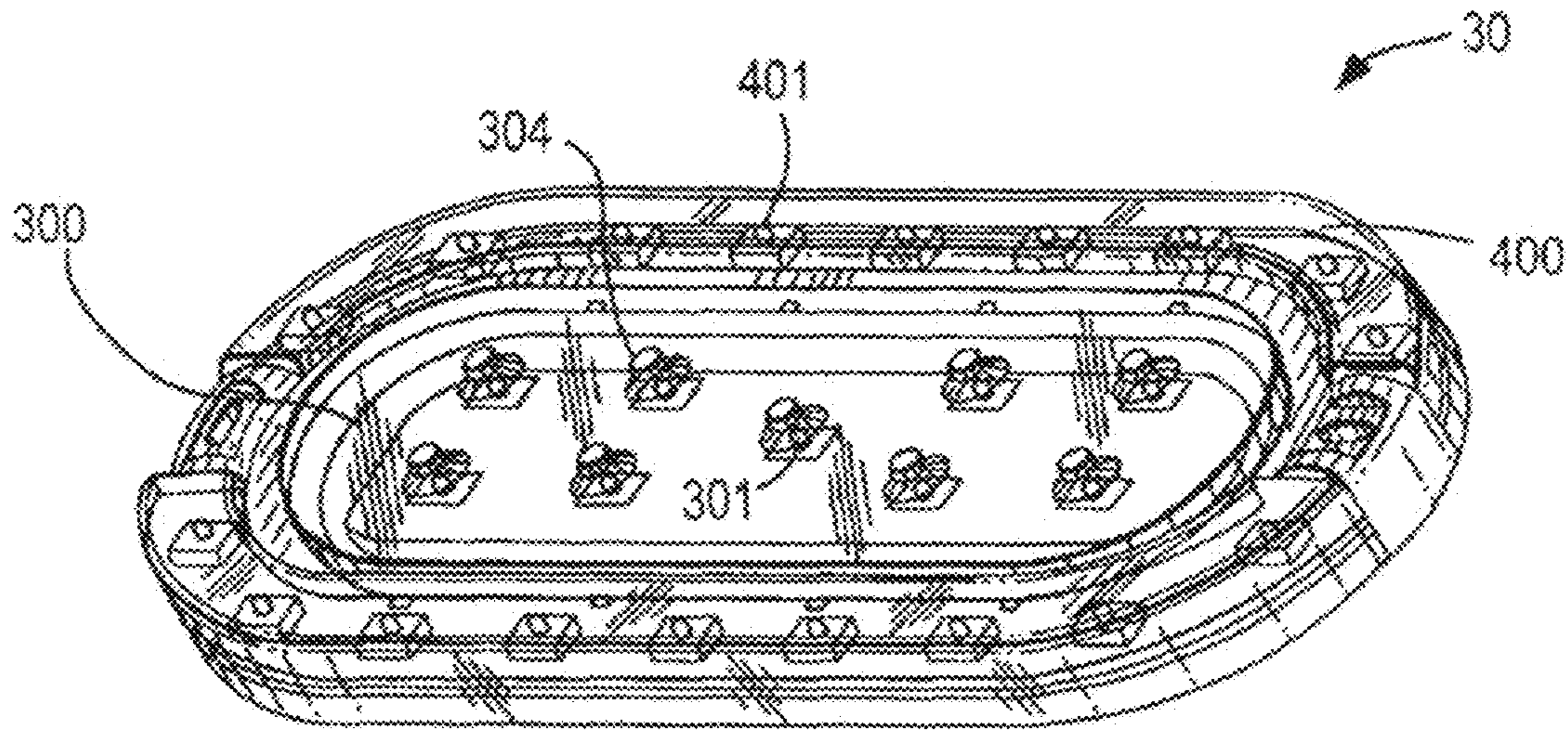

FIG. 5

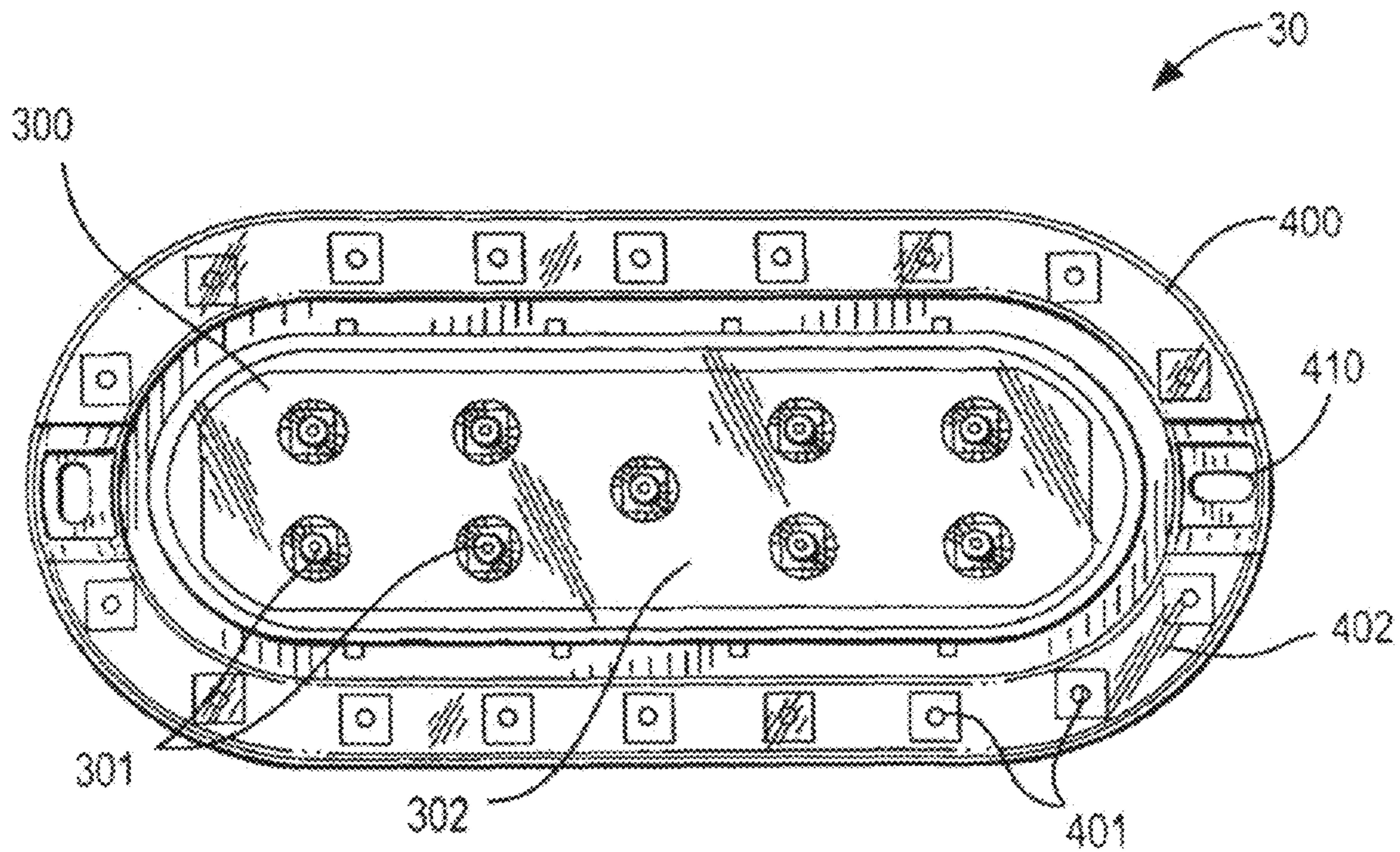

FIG. 6

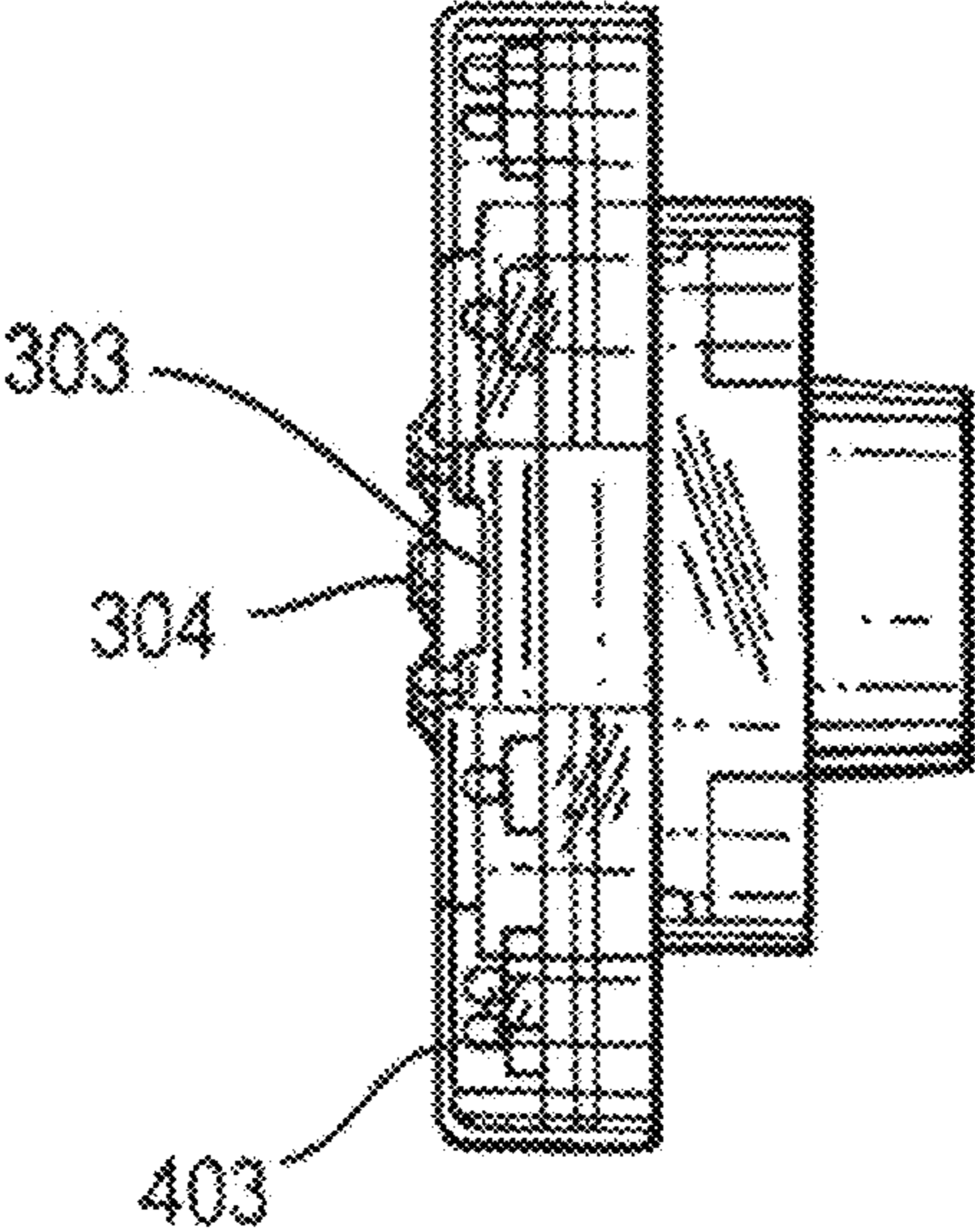

FIG. 7

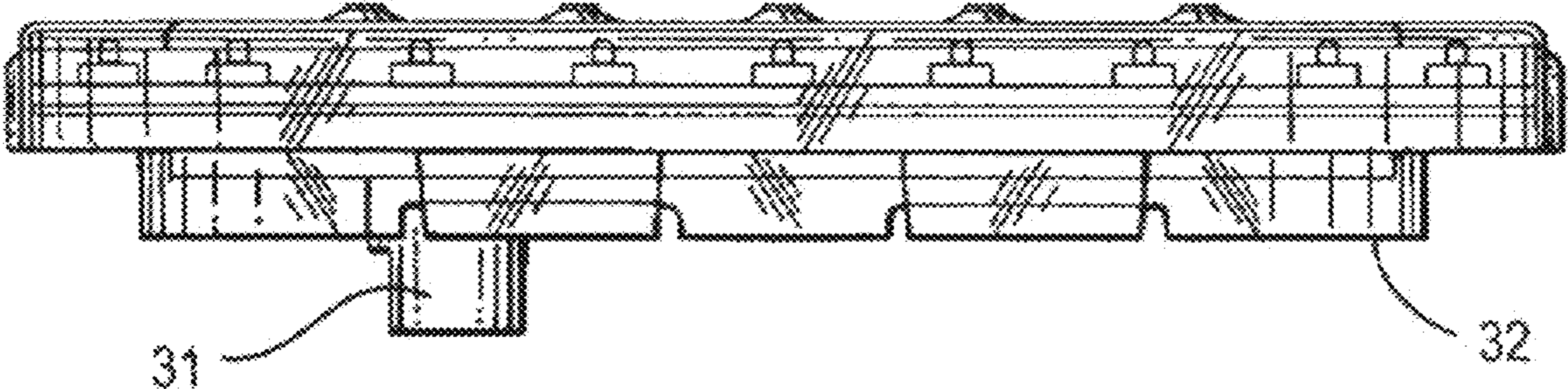

FIG. 8

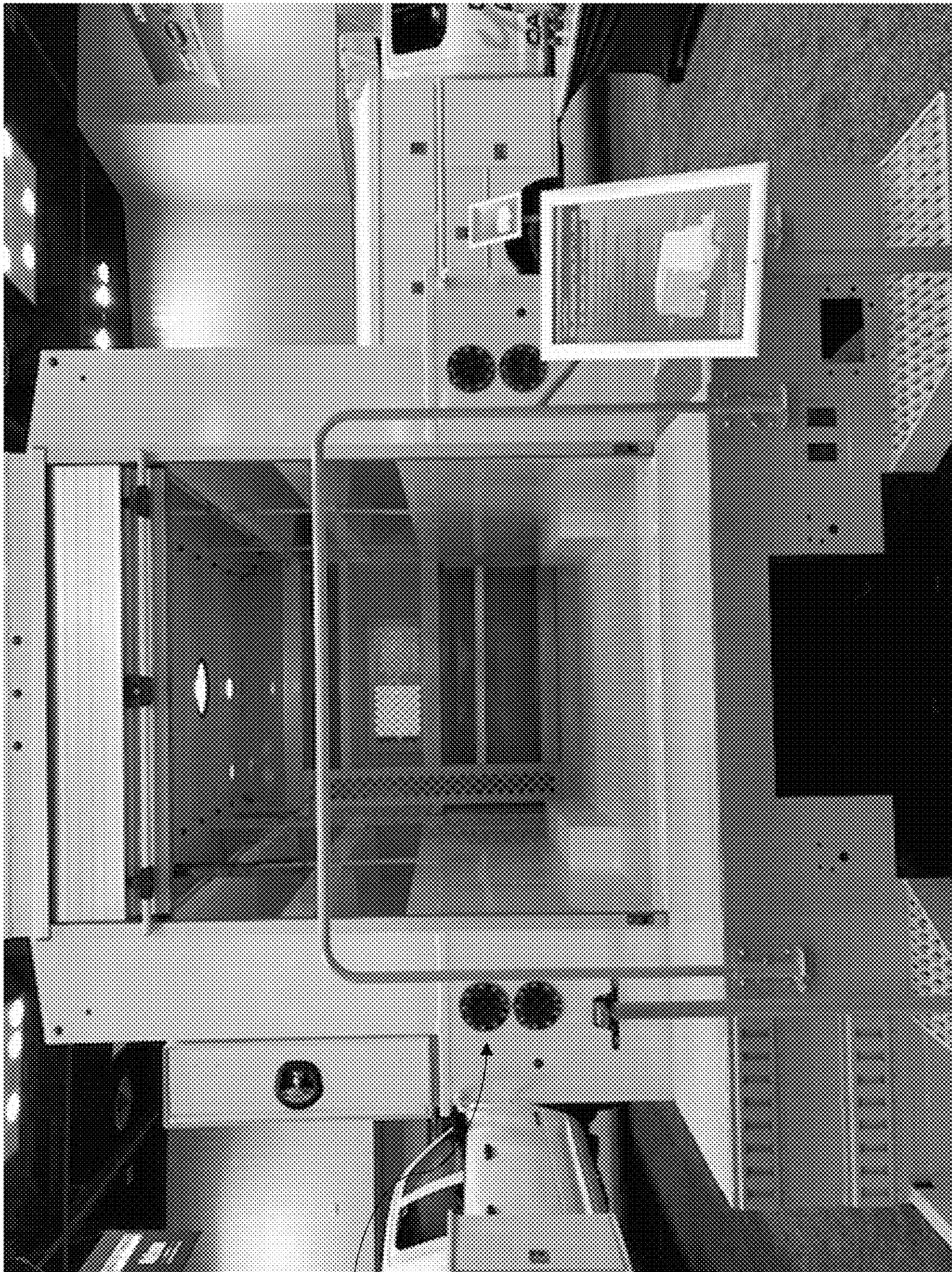

FIG. 9

10

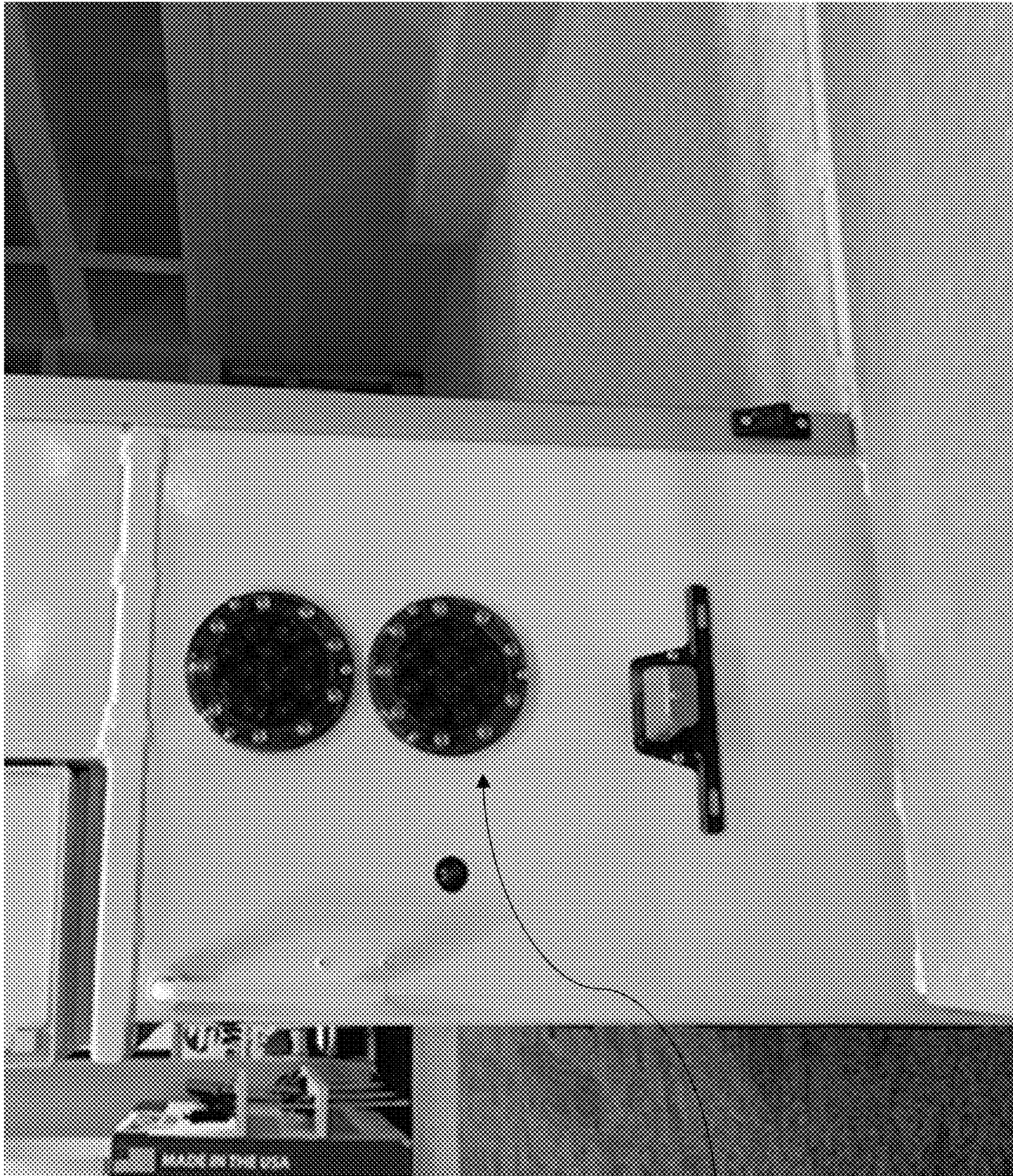

FIG. 10

10

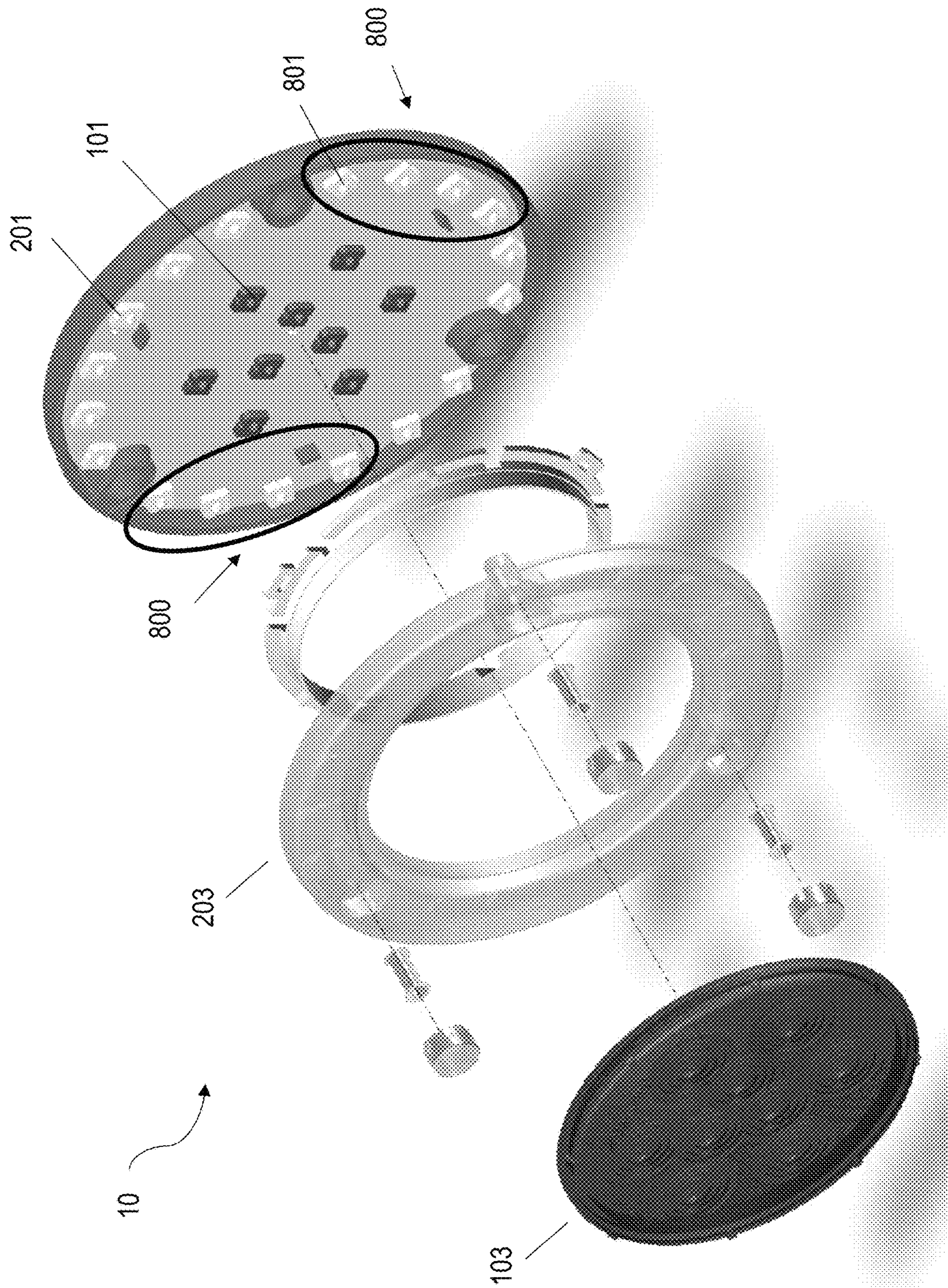

FIG. 11



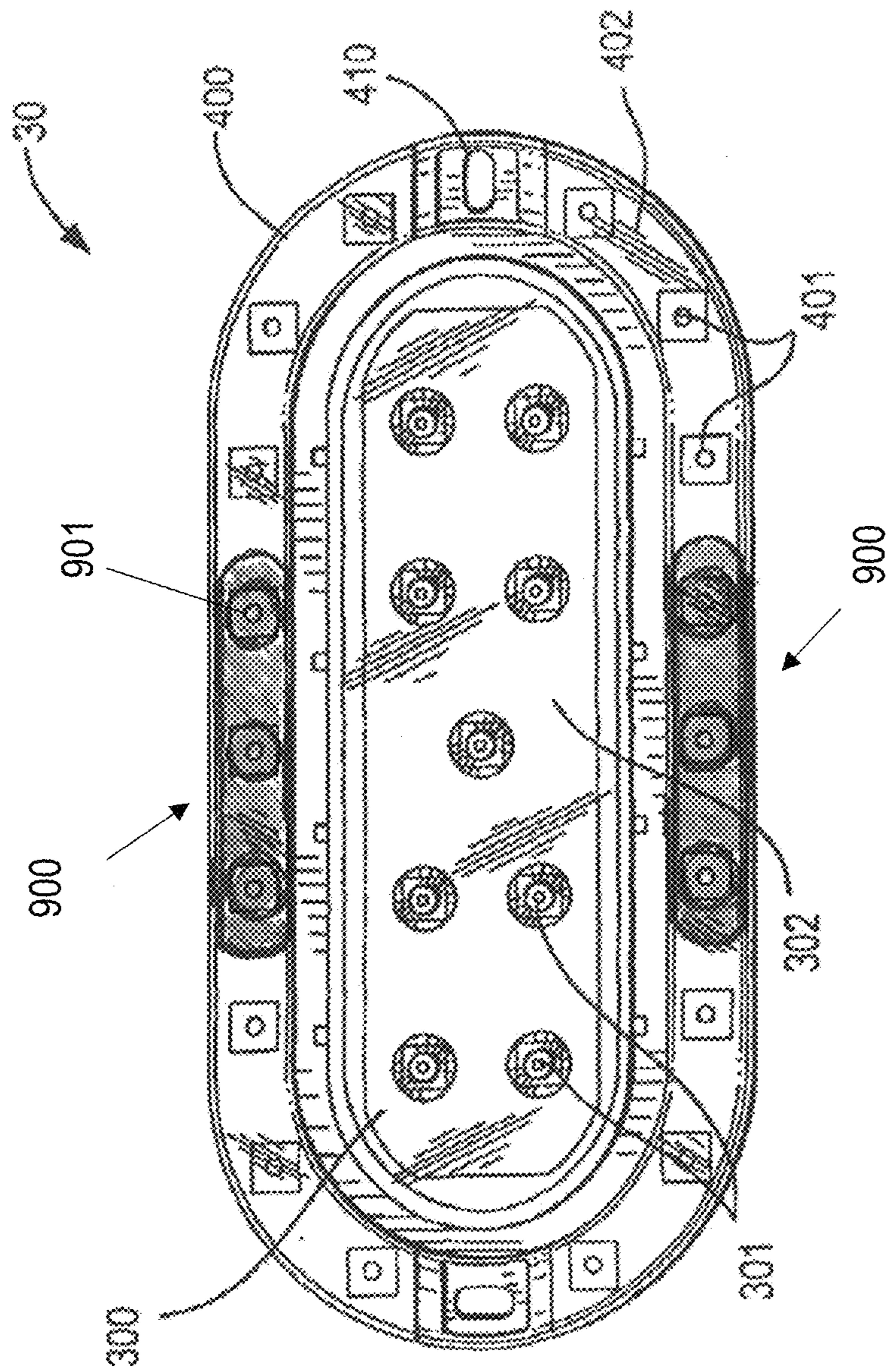

FIG. 12

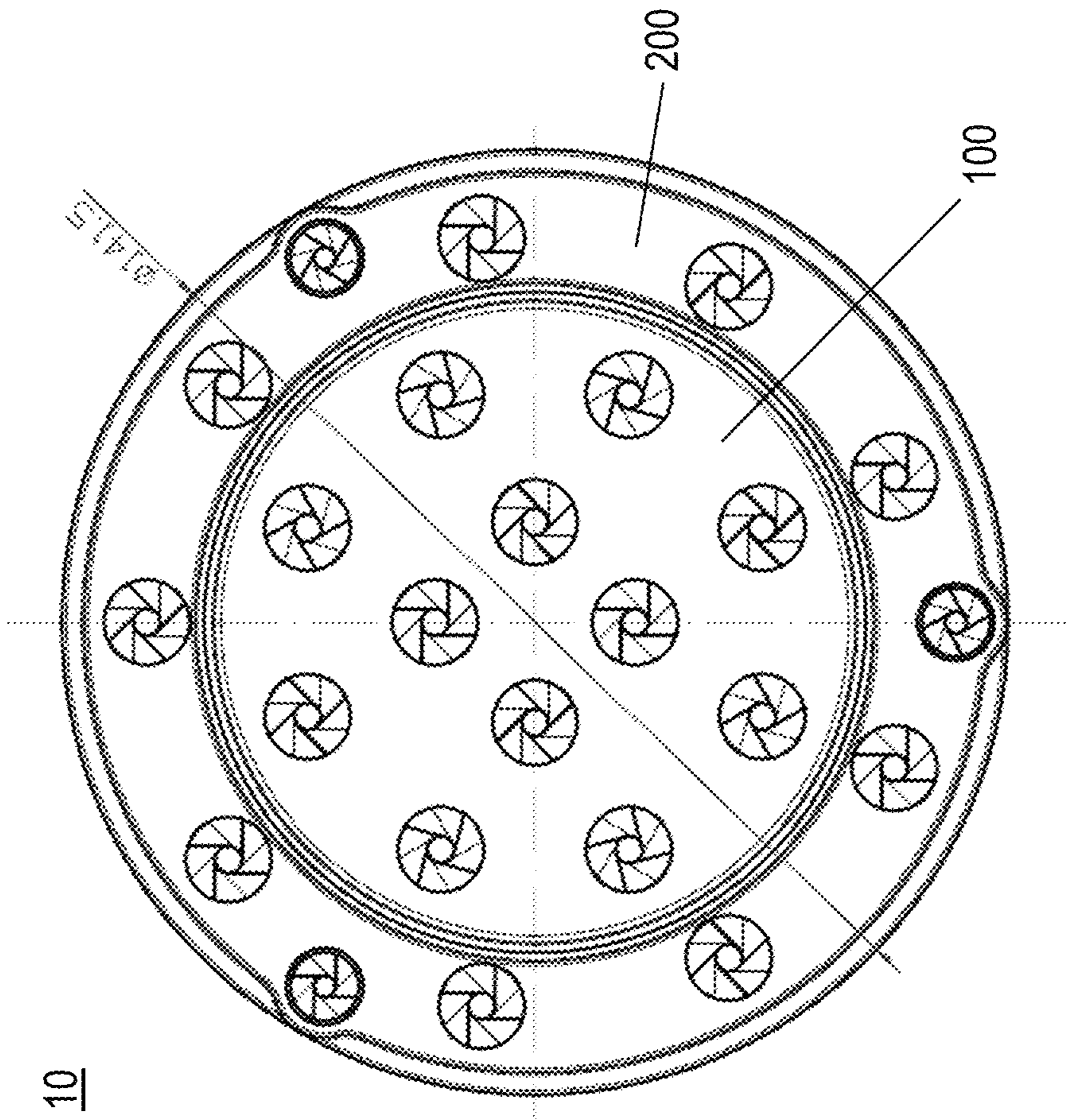

FIG. 13

10

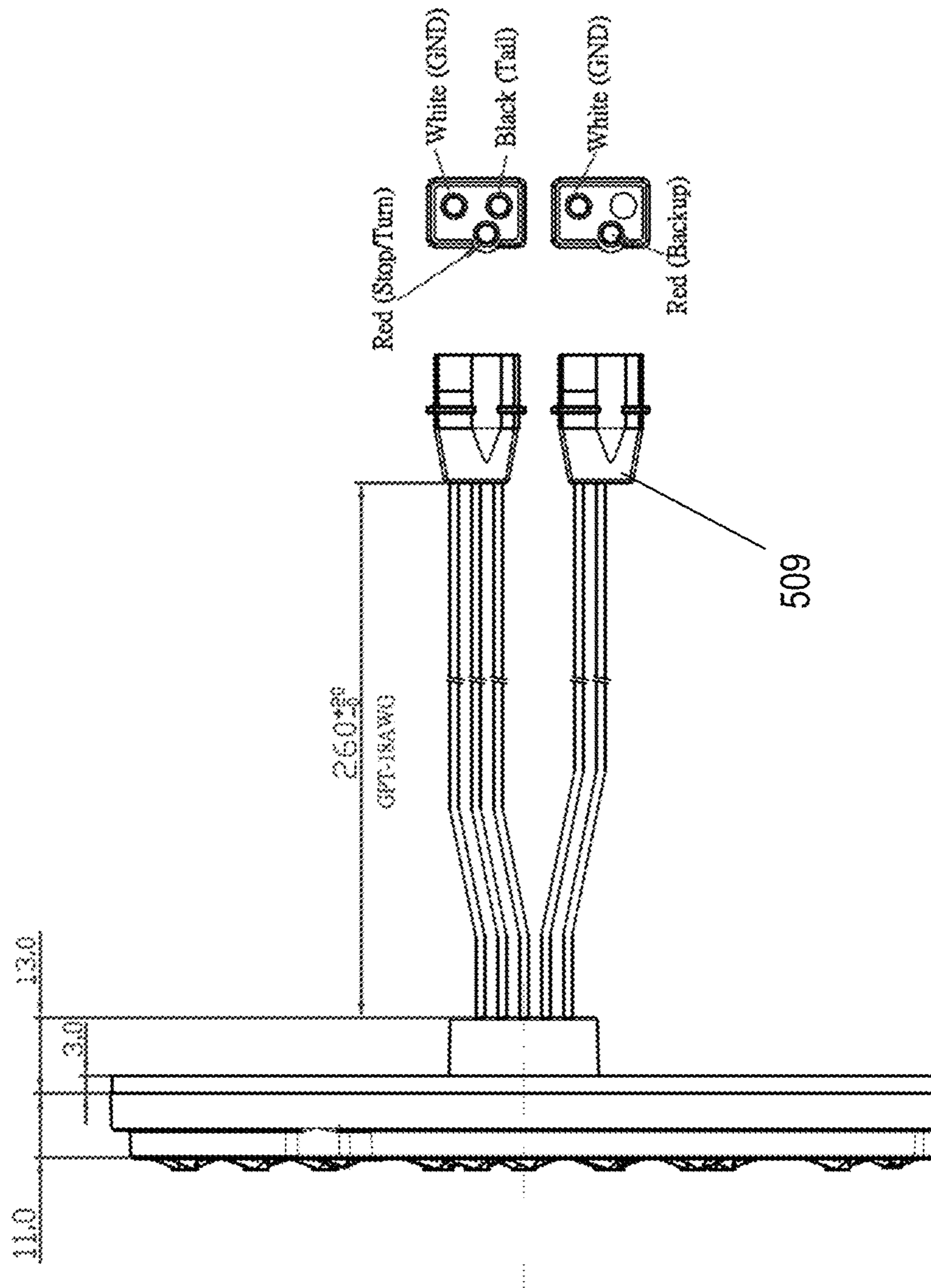

FIG. 14

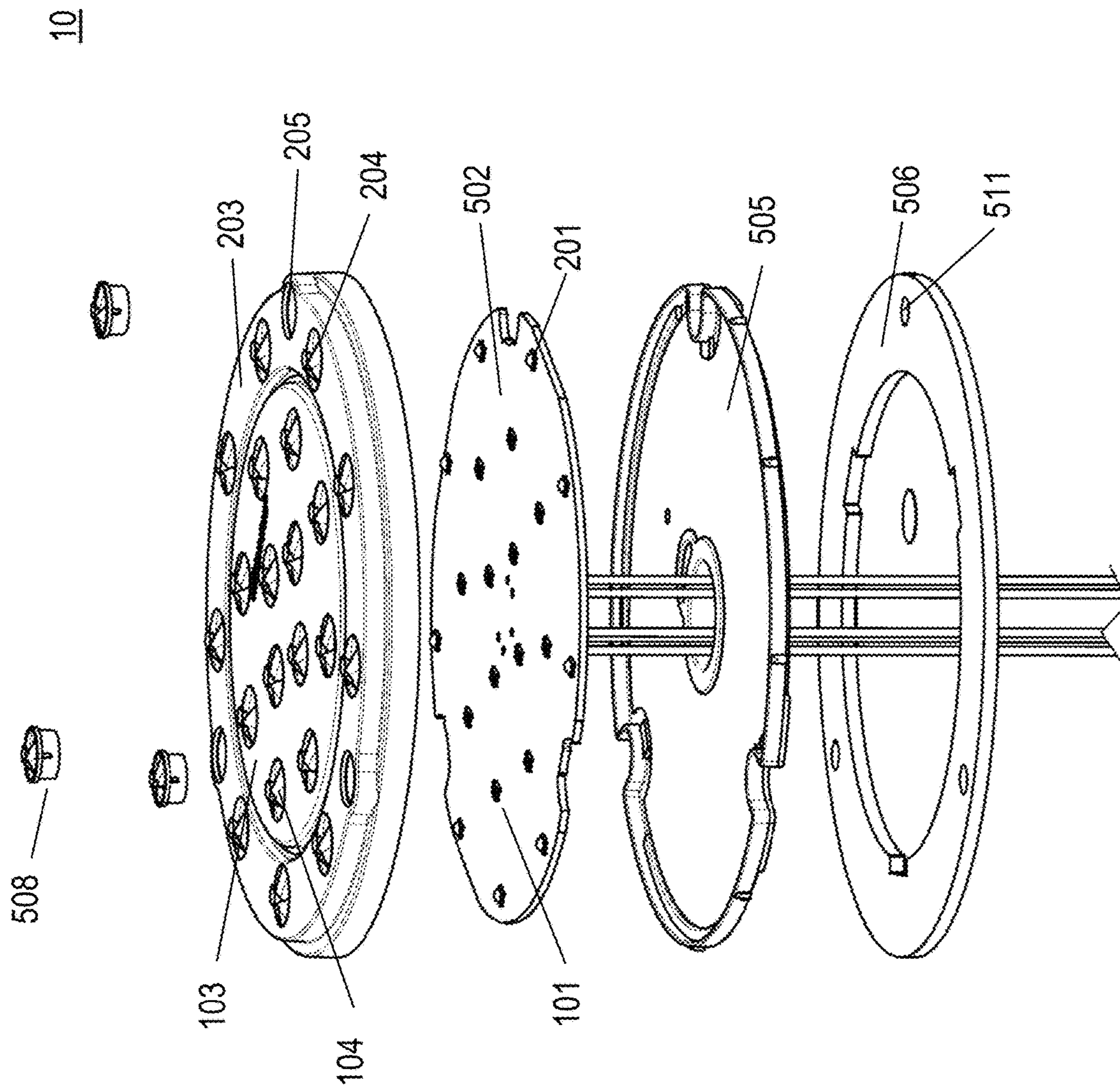

FIG. 15

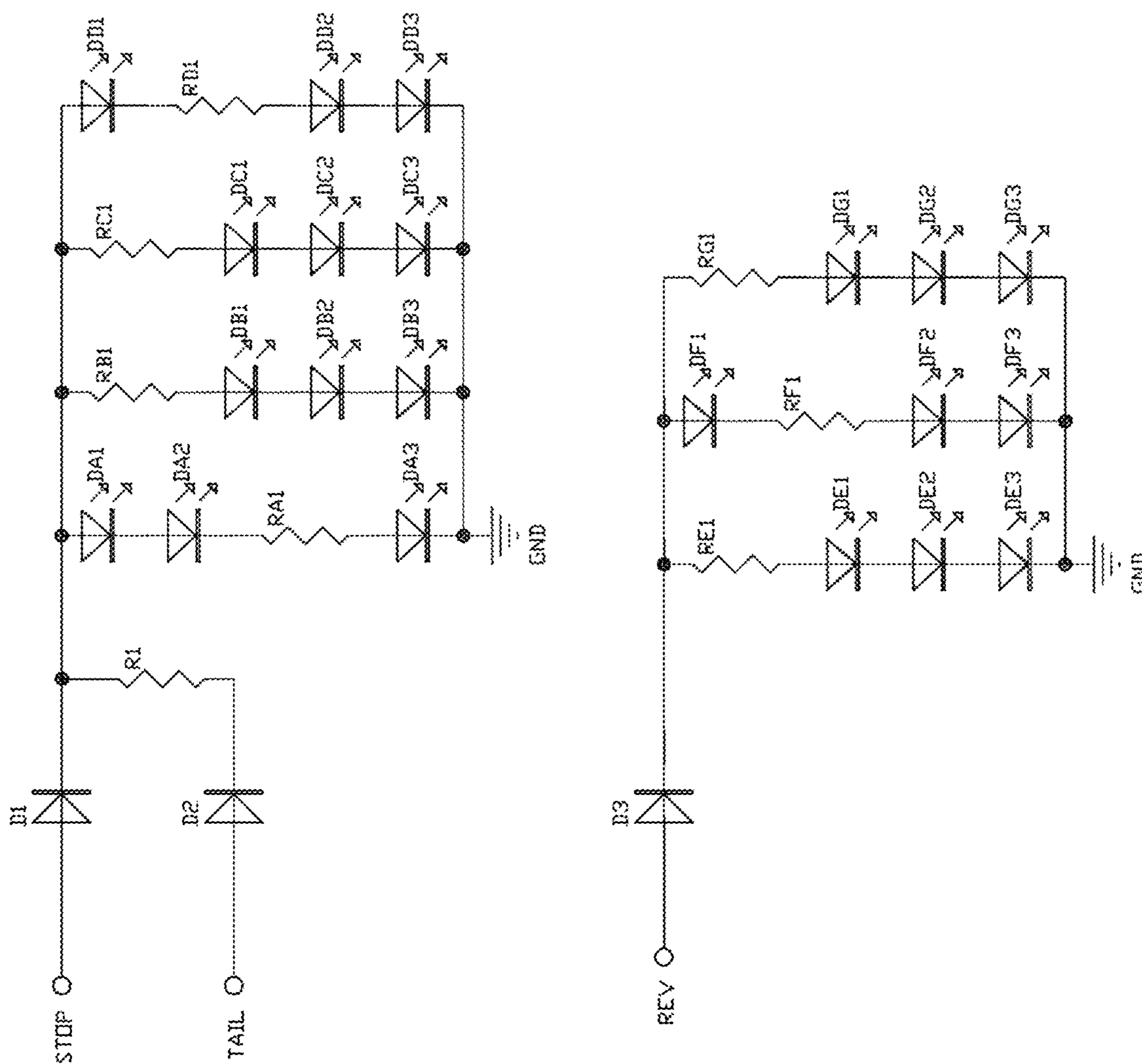

FIG. 16

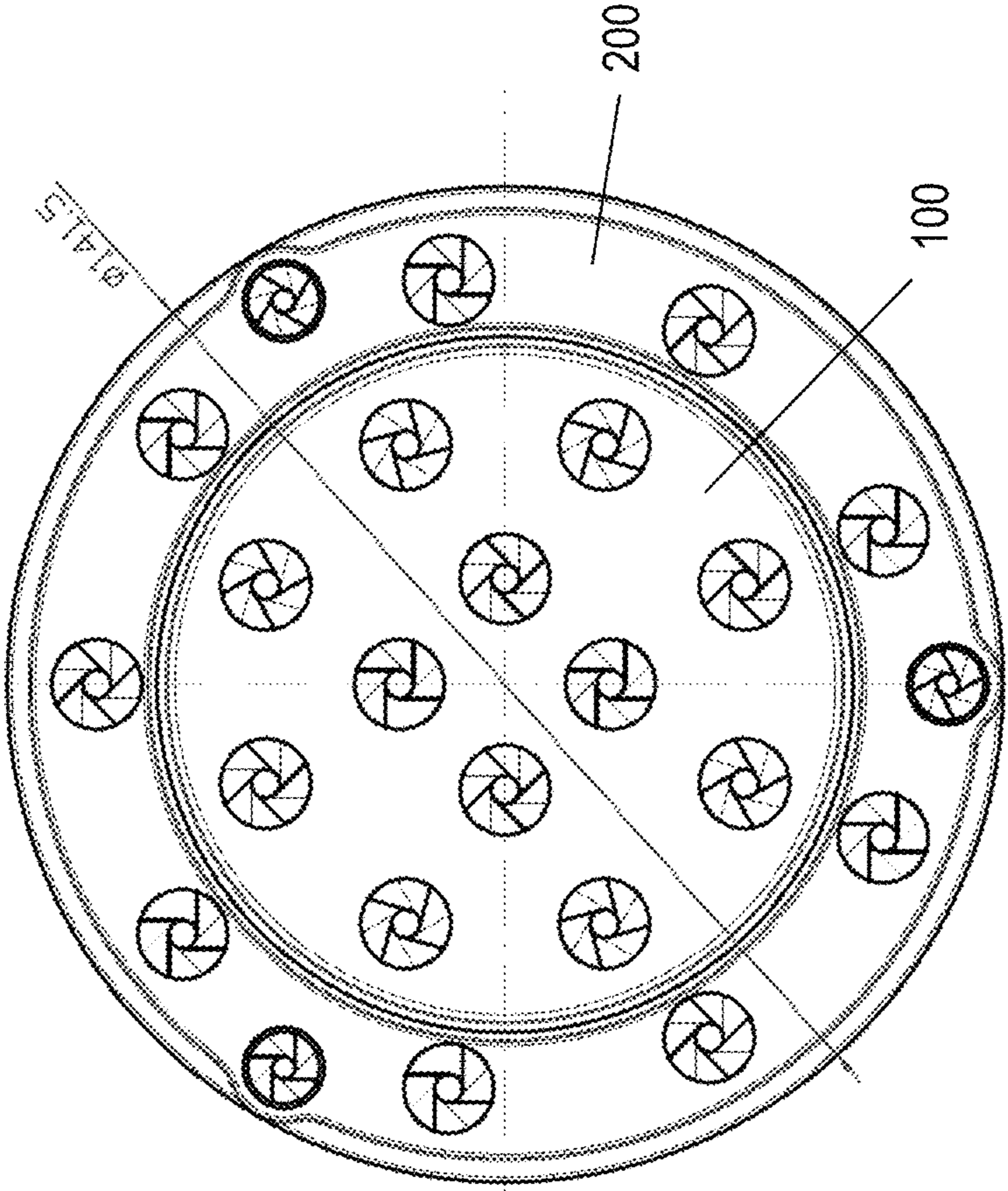

FIG. 17

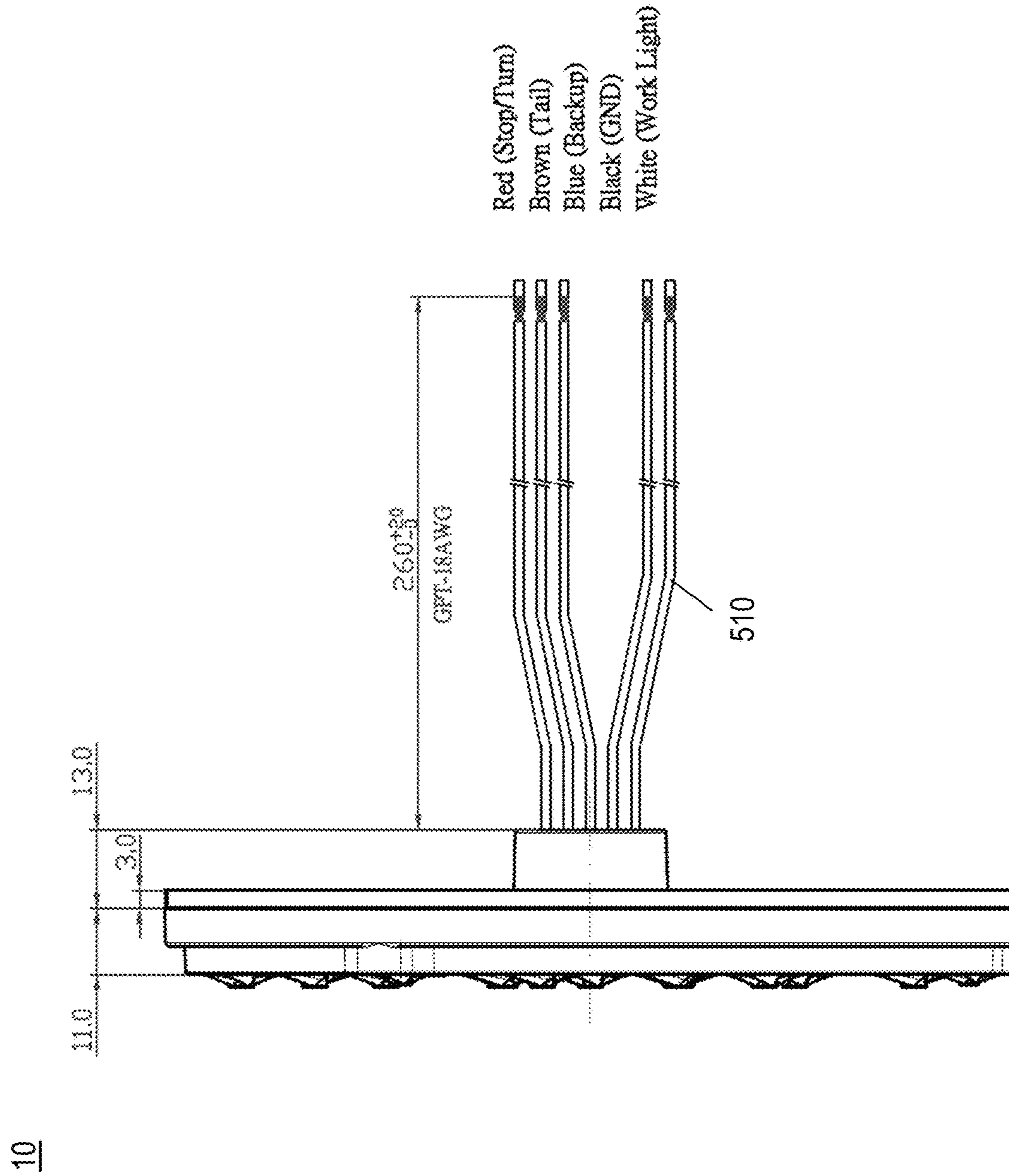

FIG. 18

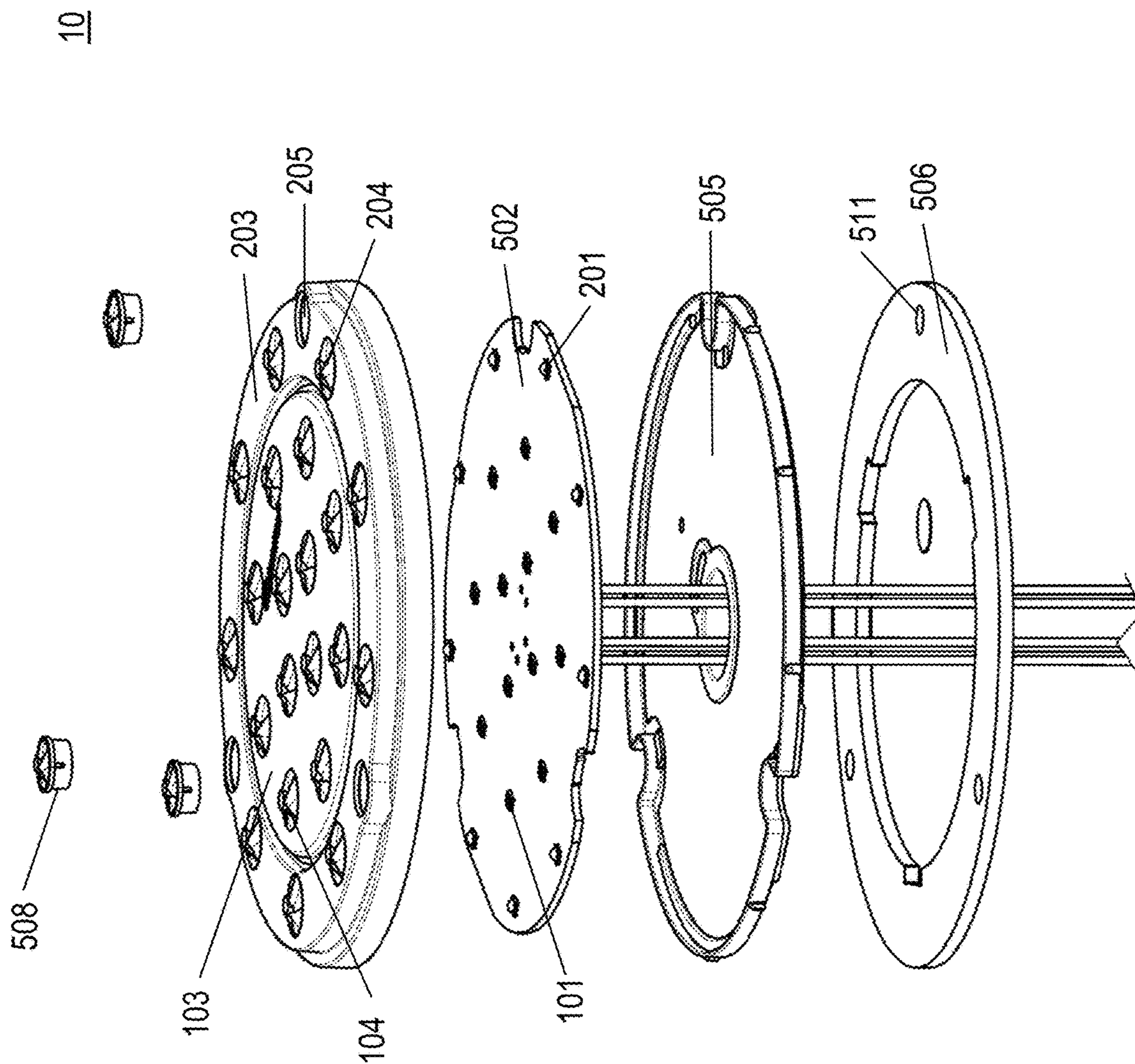

FIG. 19



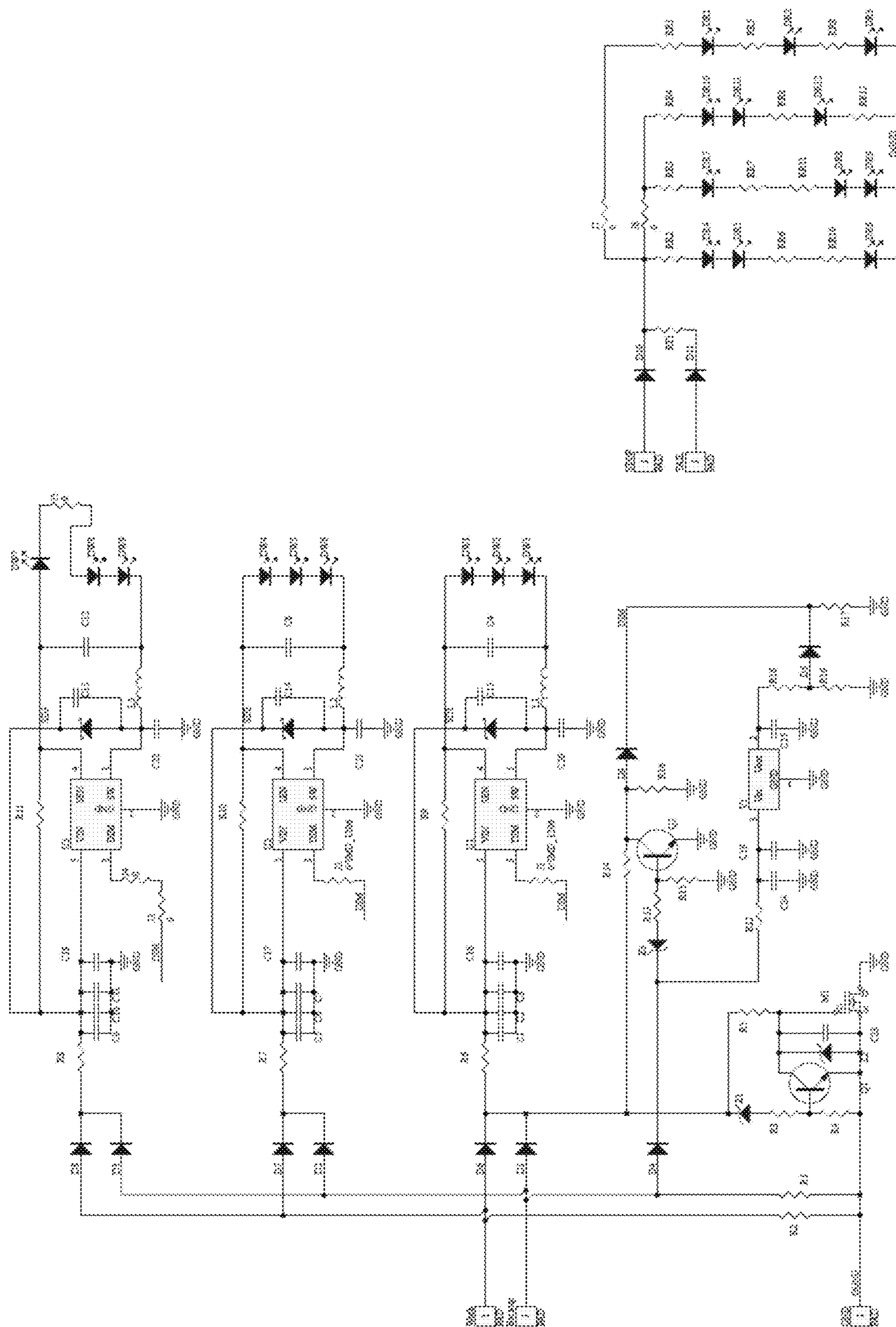

FIG. 20

10

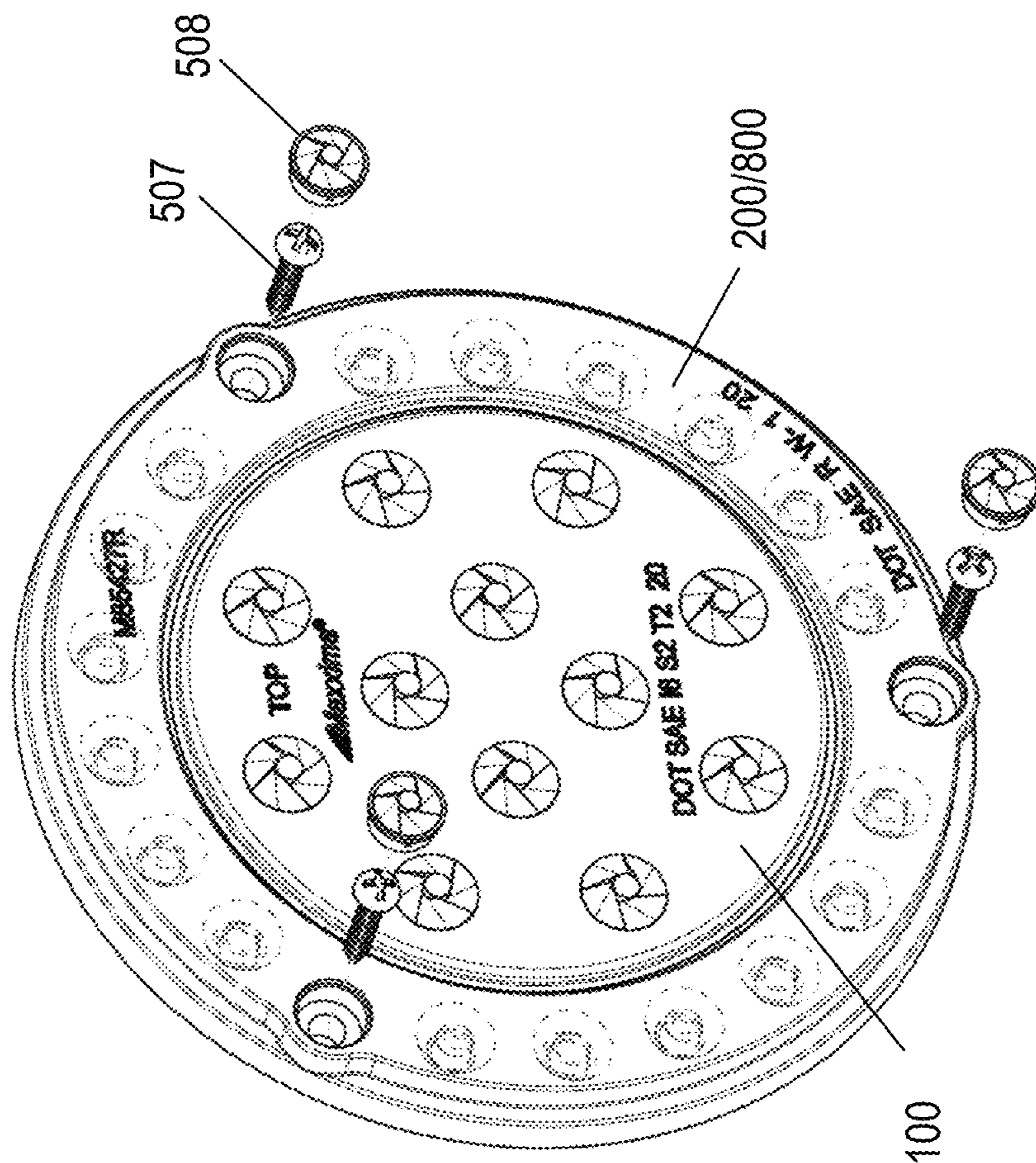
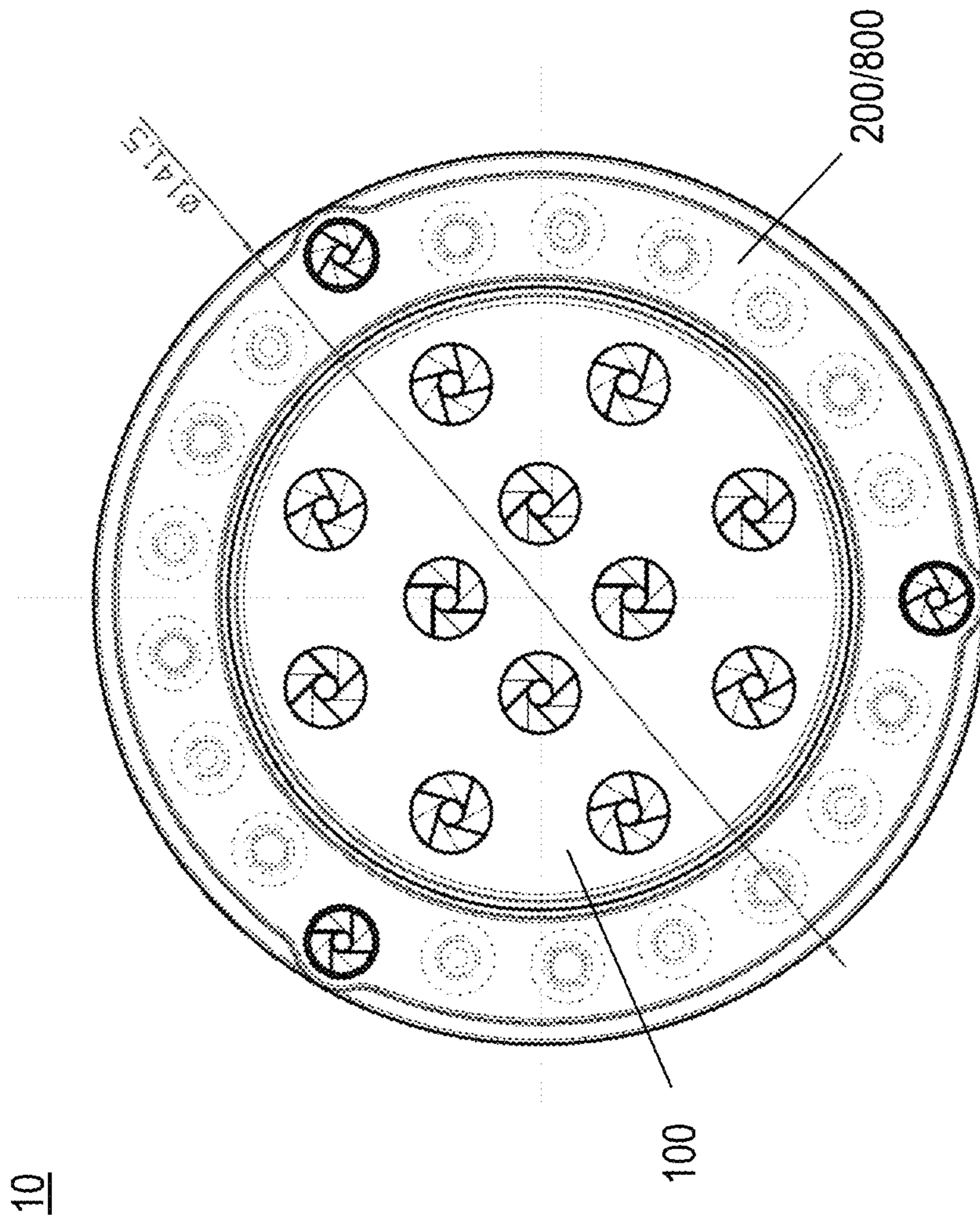

FIG. 21



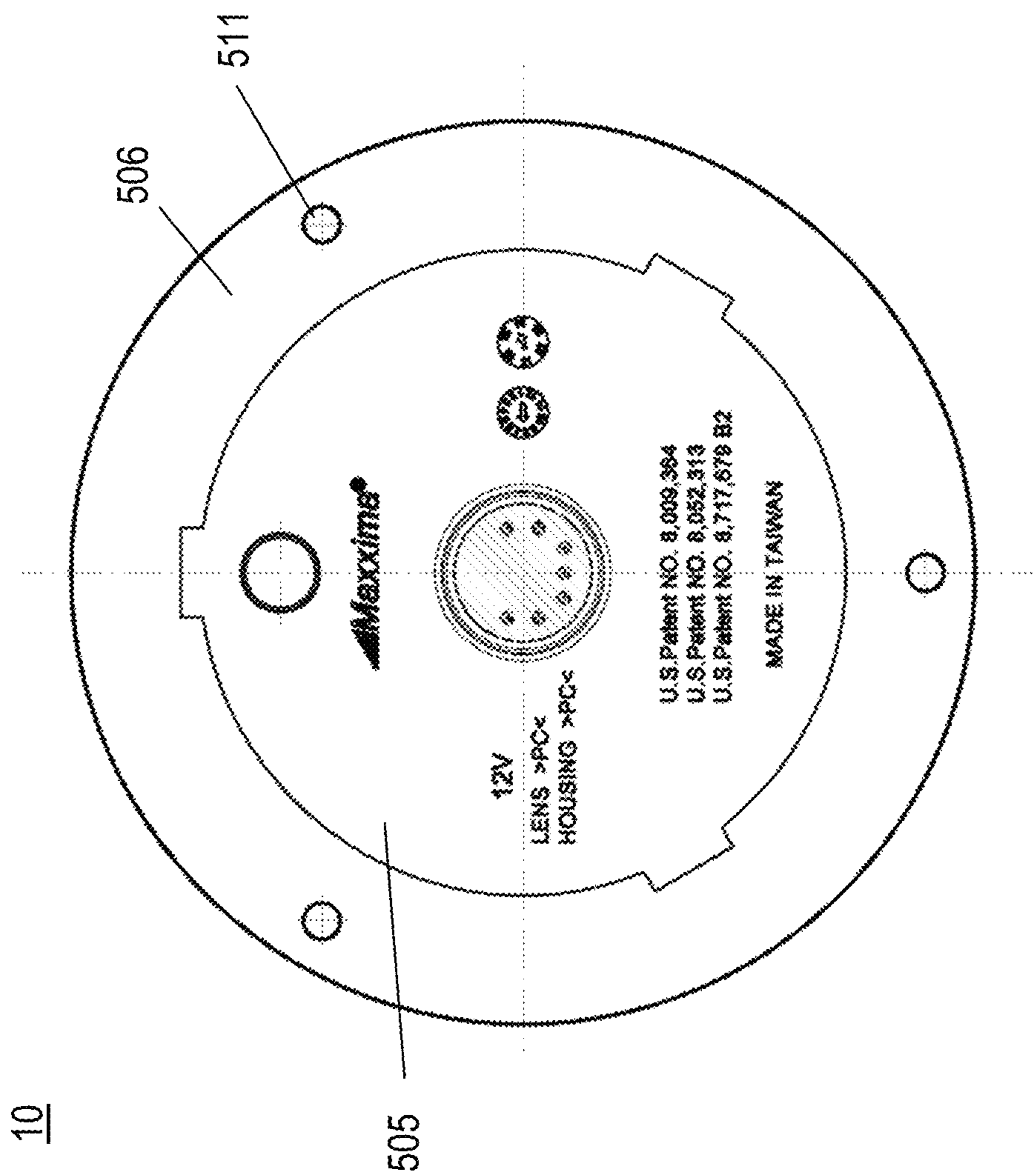

FIG. 23

10

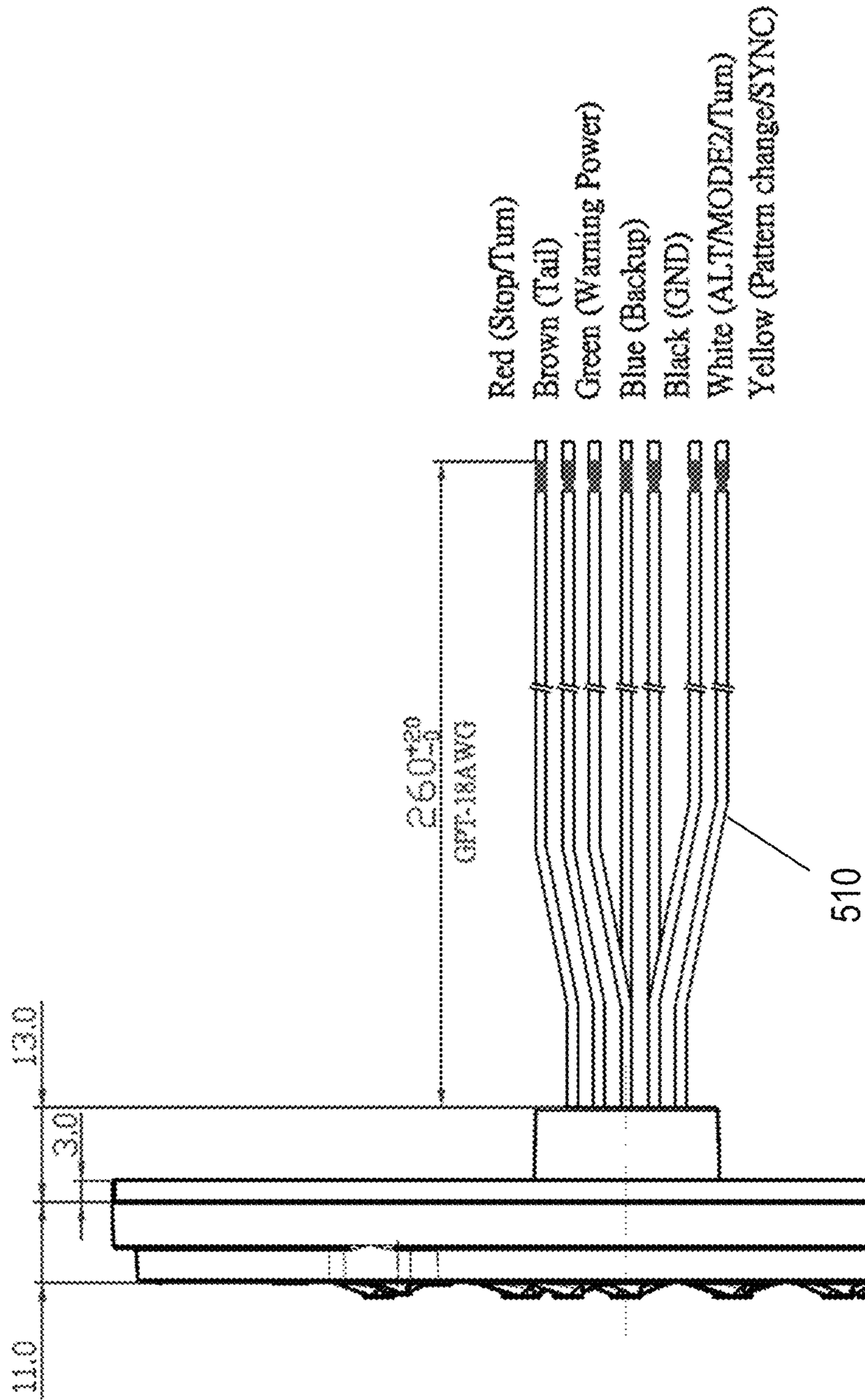

FIG. 24

10

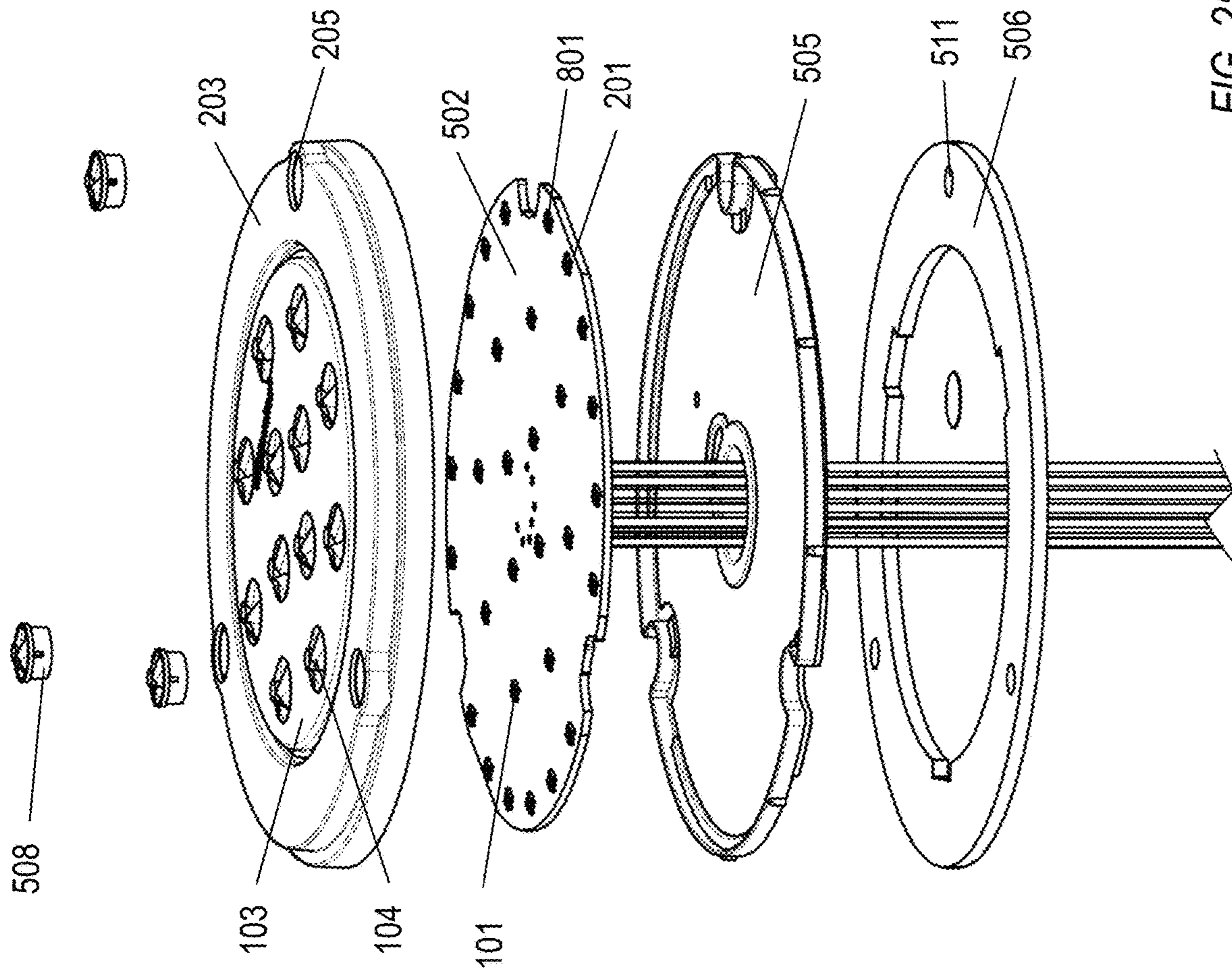

FIG. 25

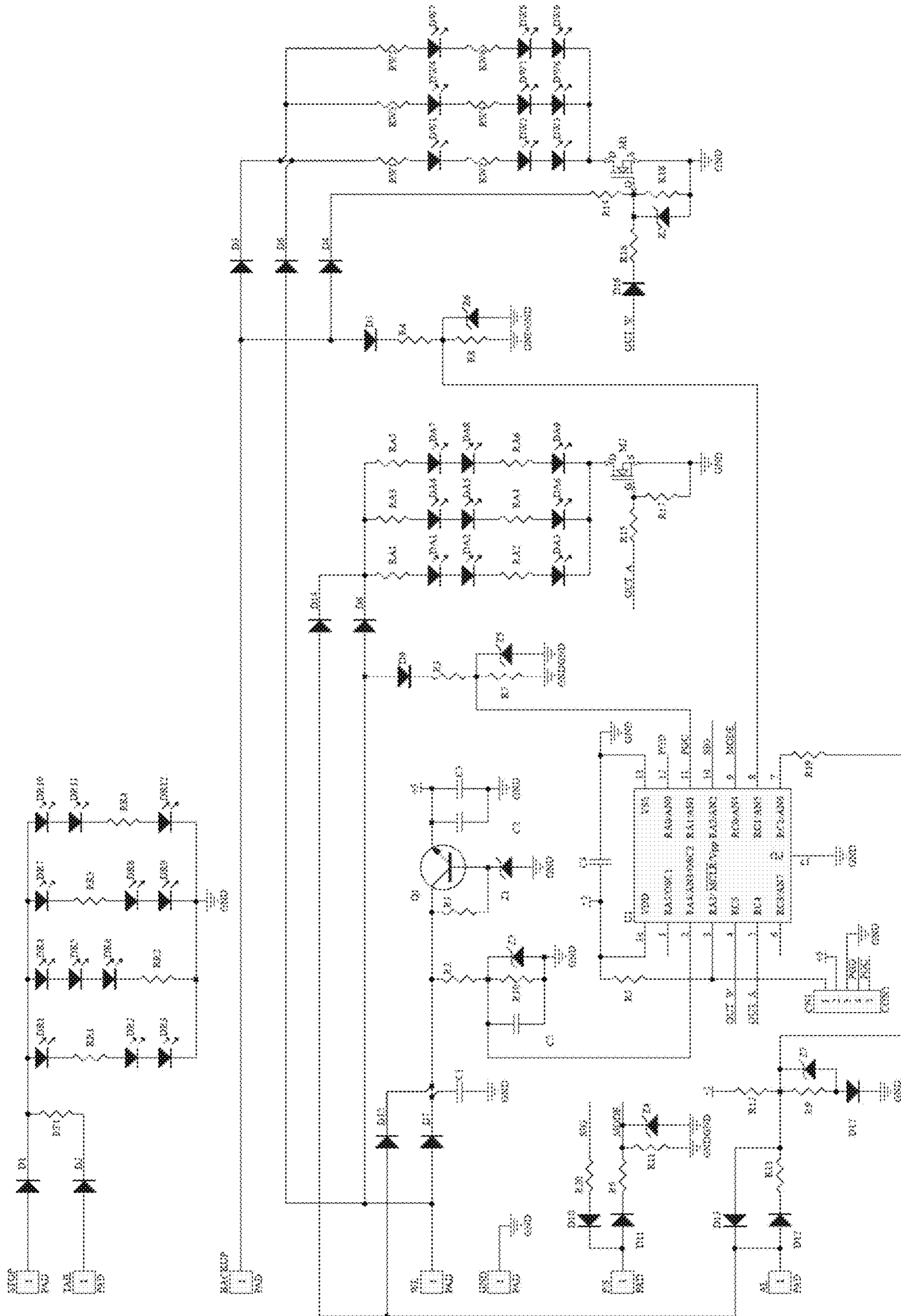
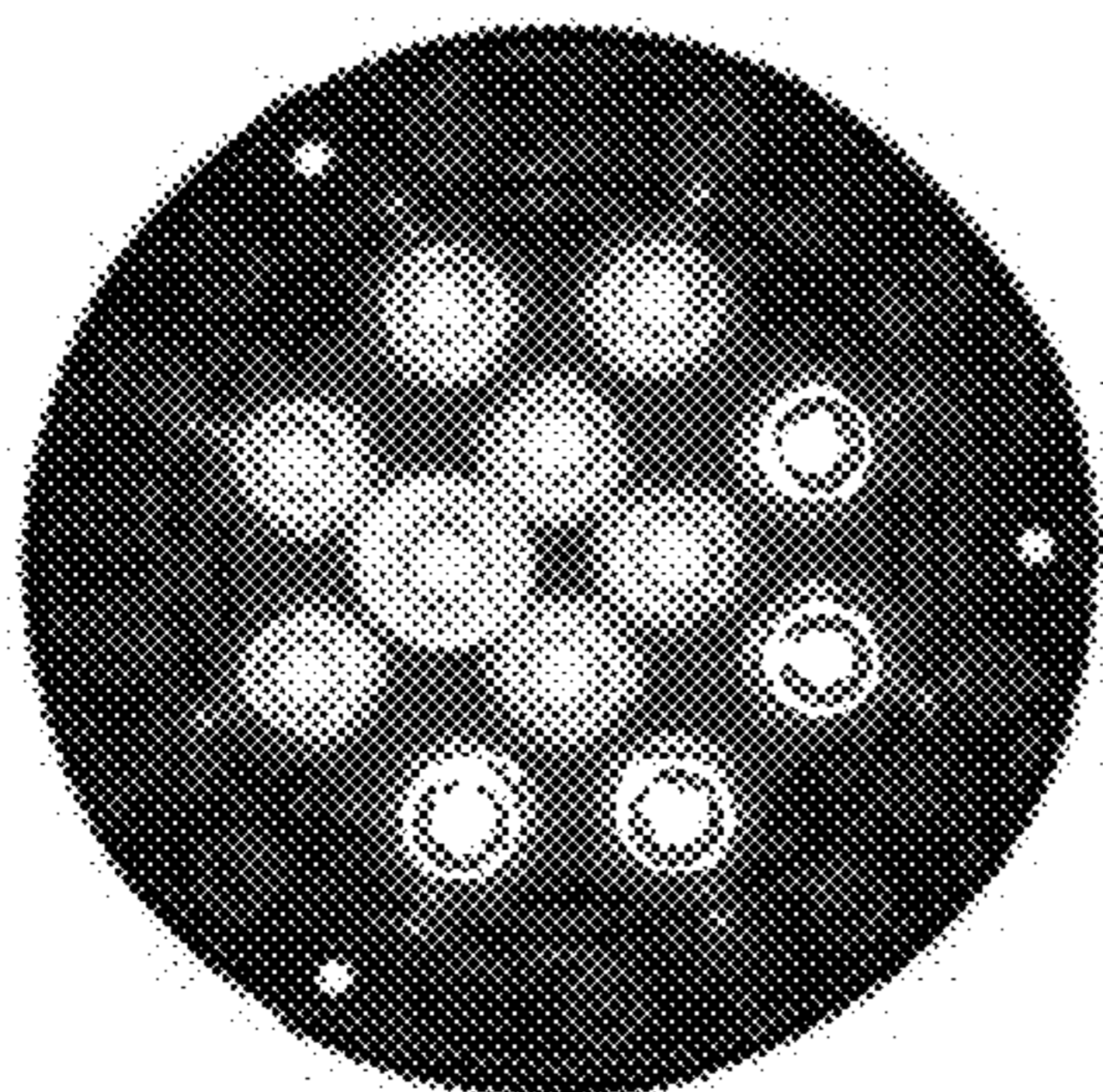

FIG. 26

FIG. 27



12 LED RED  
Tail Light

FIG. 28

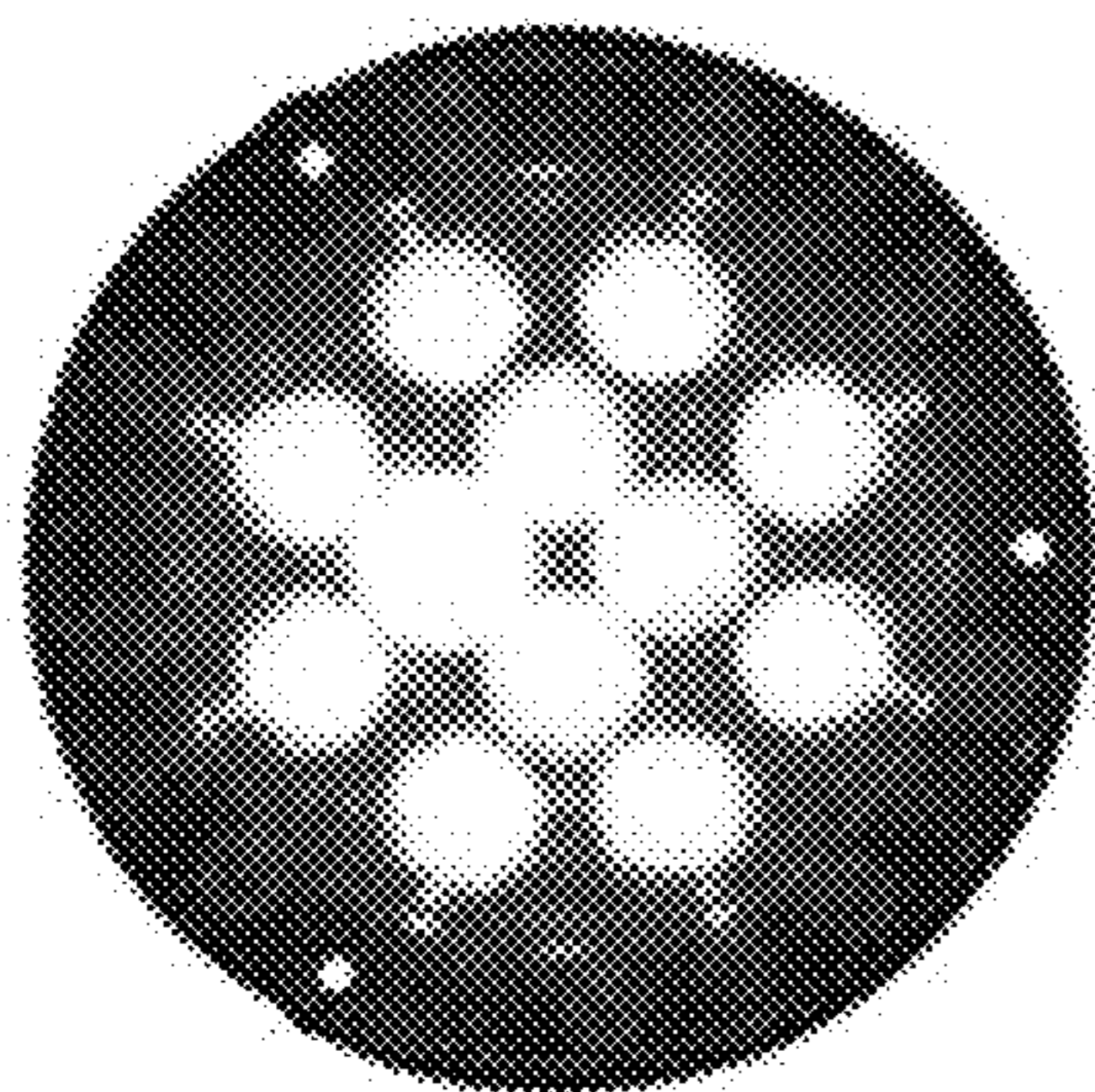

12 LED RED  
STOP Light

FIG. 29

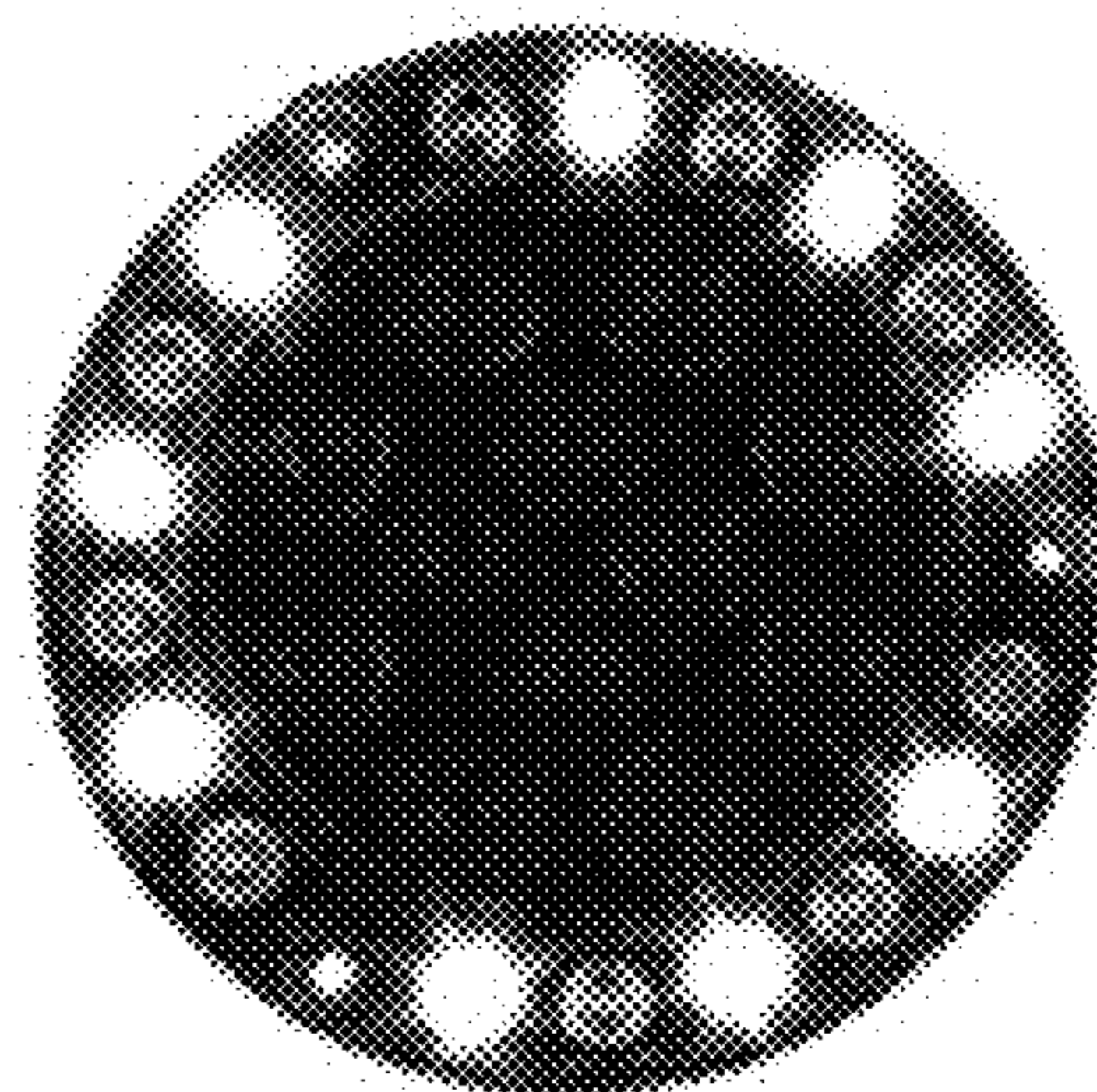

9 LED WHITE  
Back-Up Light

FIG. 30

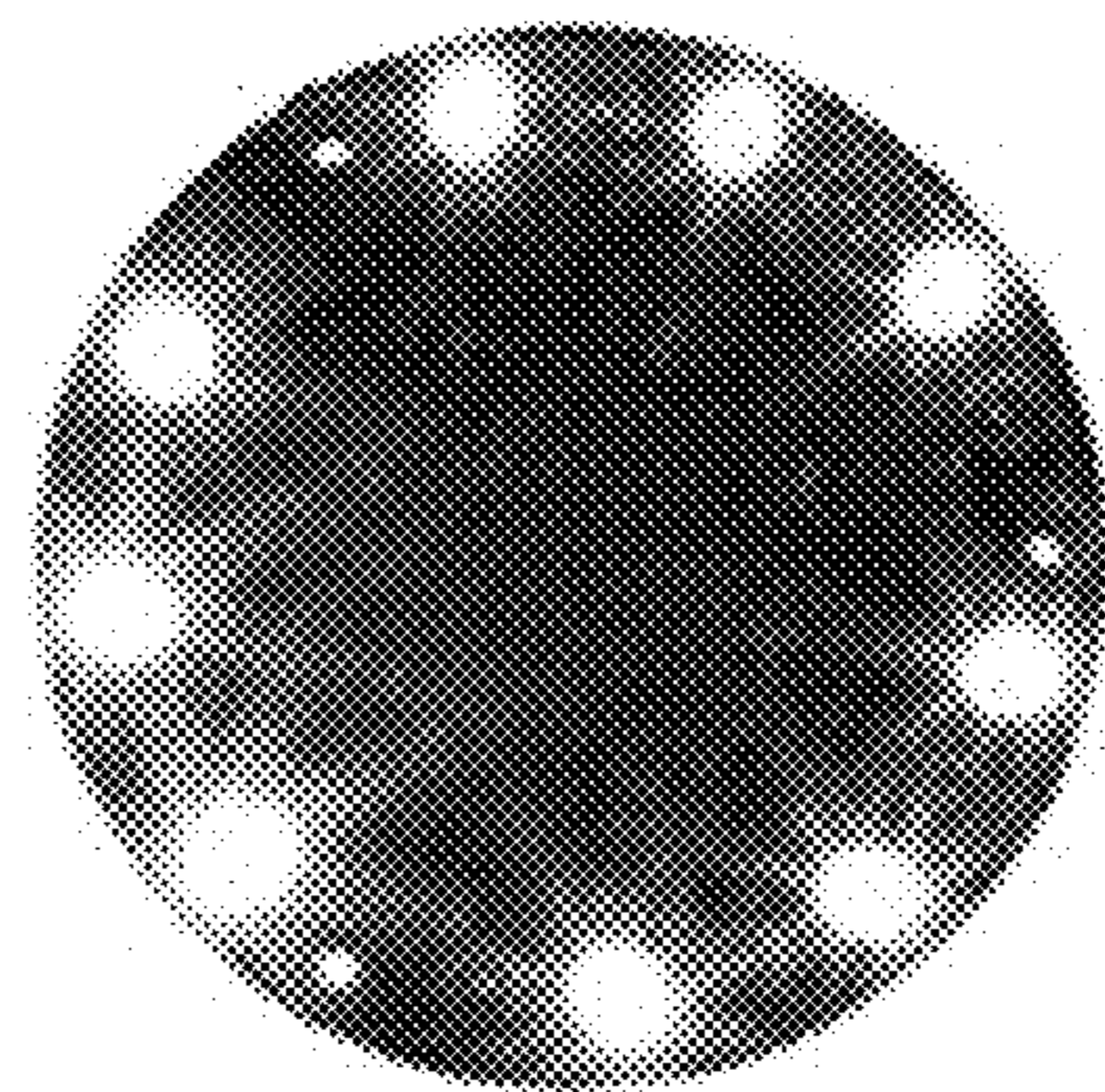

9 LED Amber  
Warning & Turn



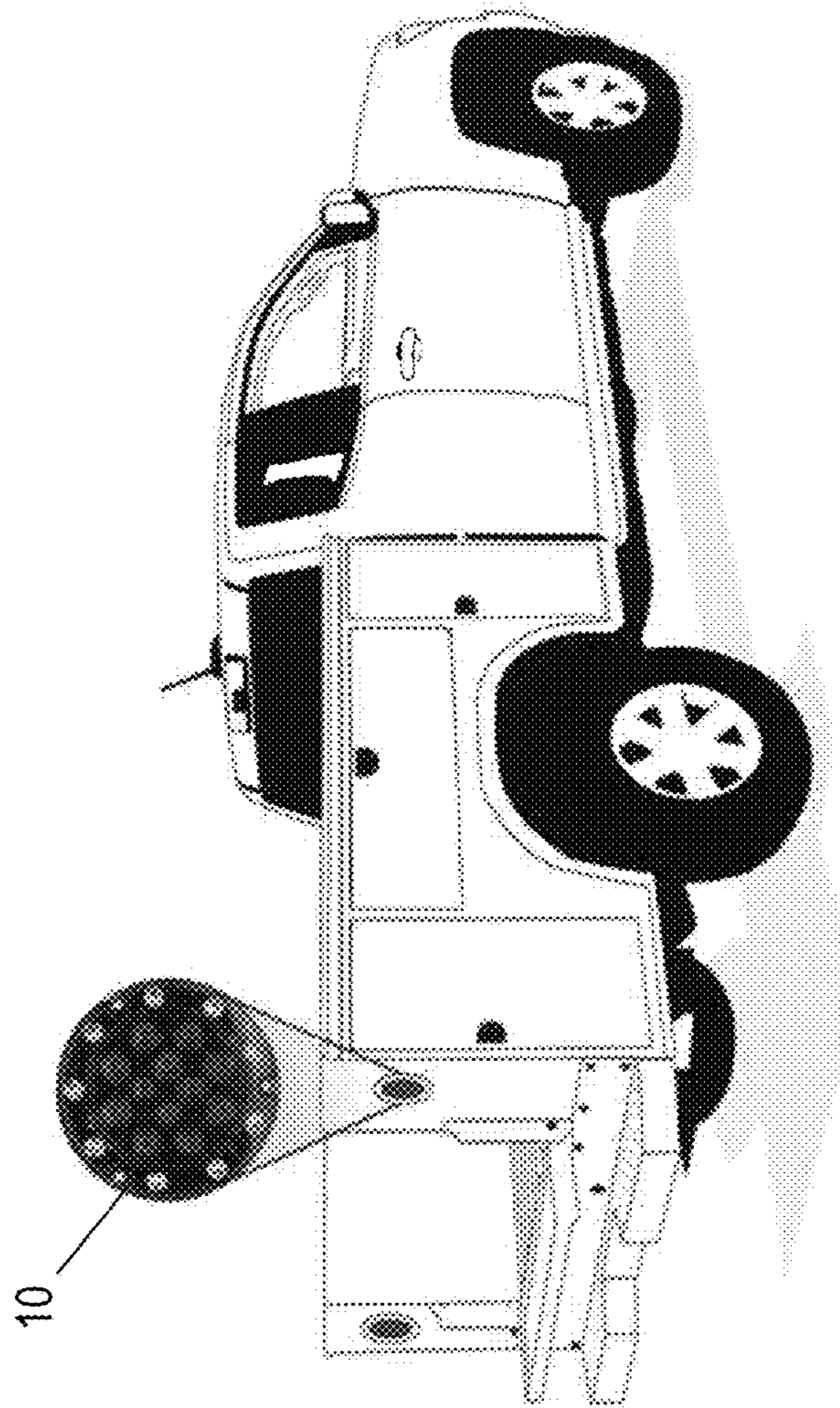

FIG. 31

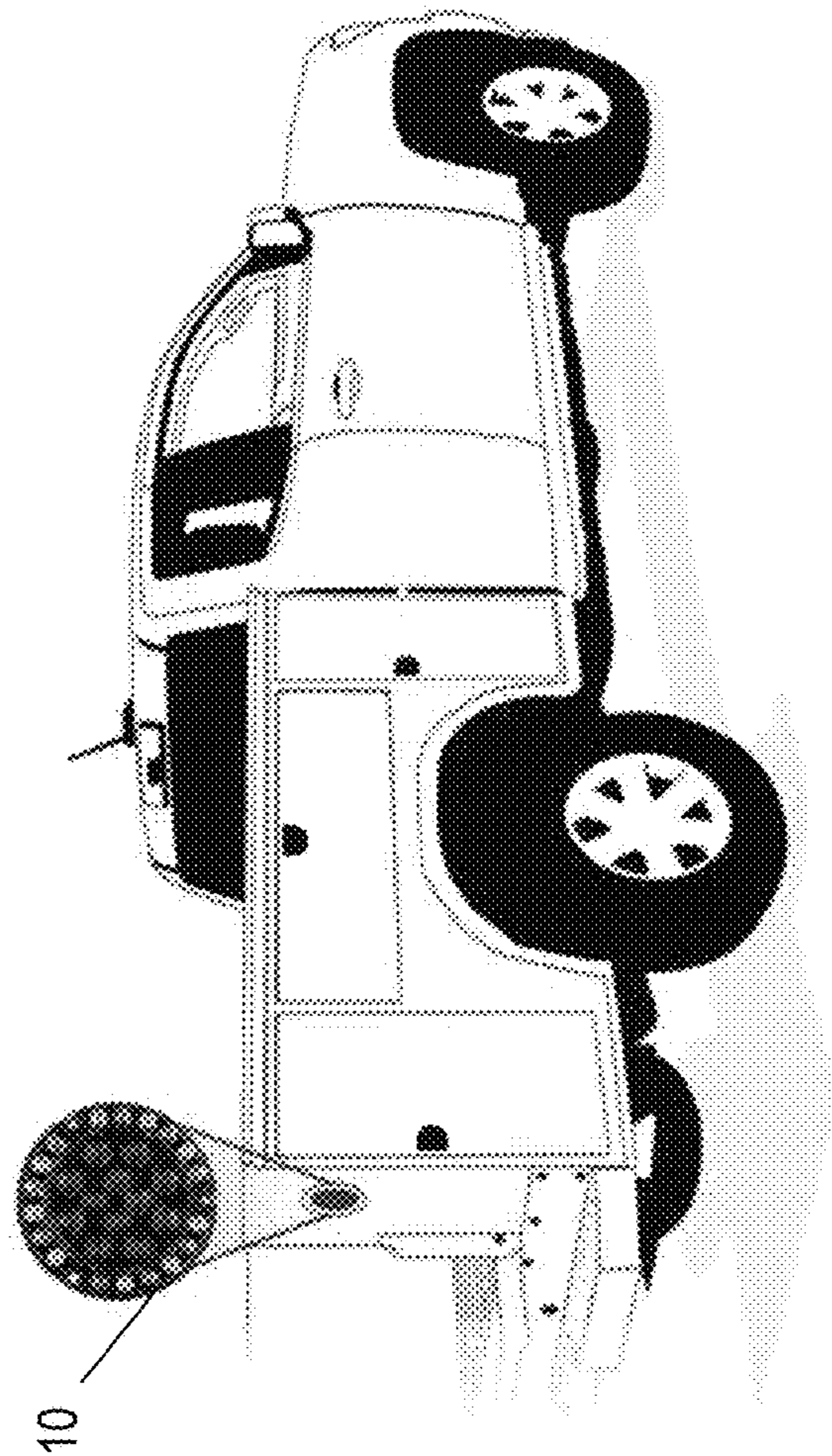

FIG. 32

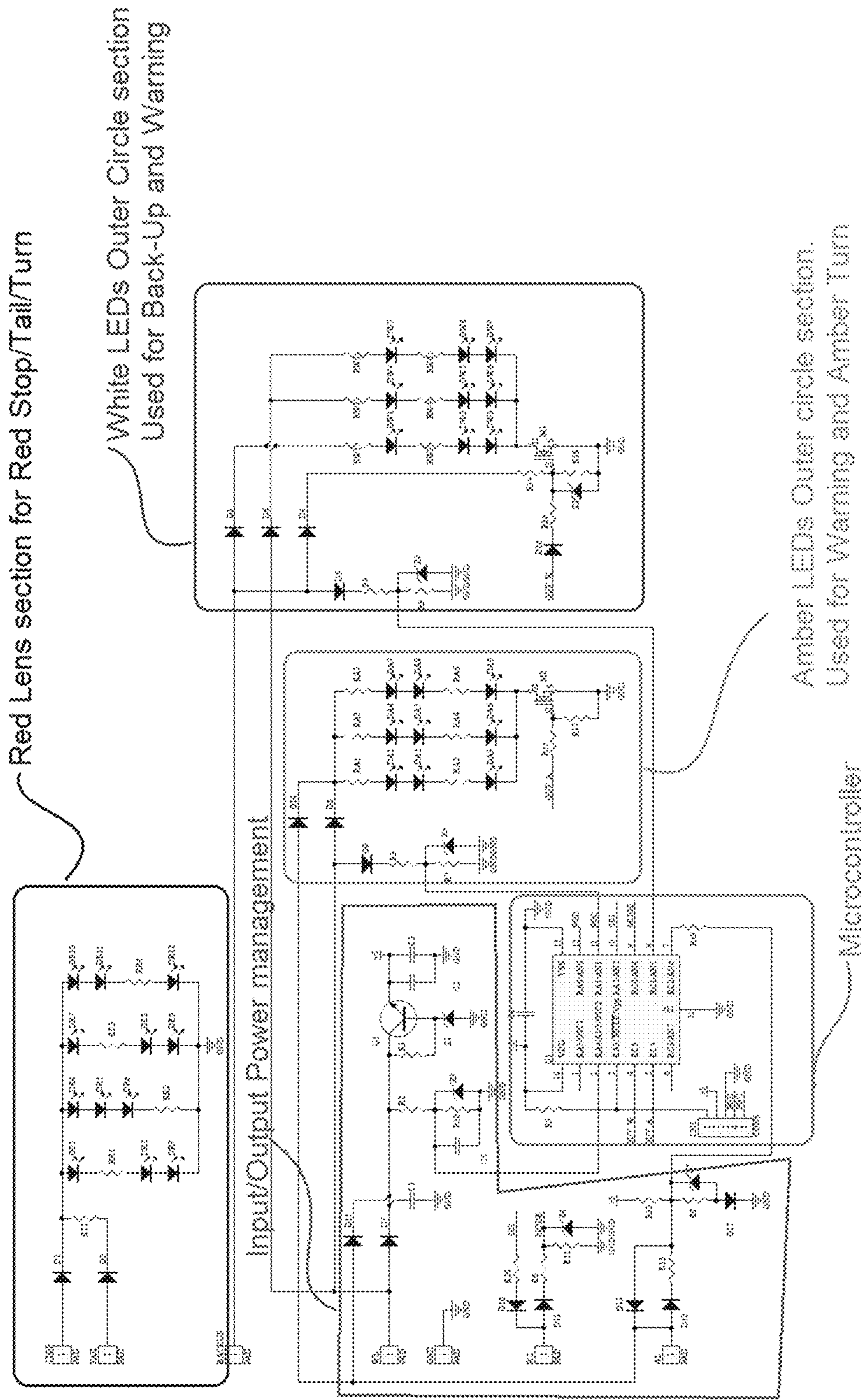

FIG. 33

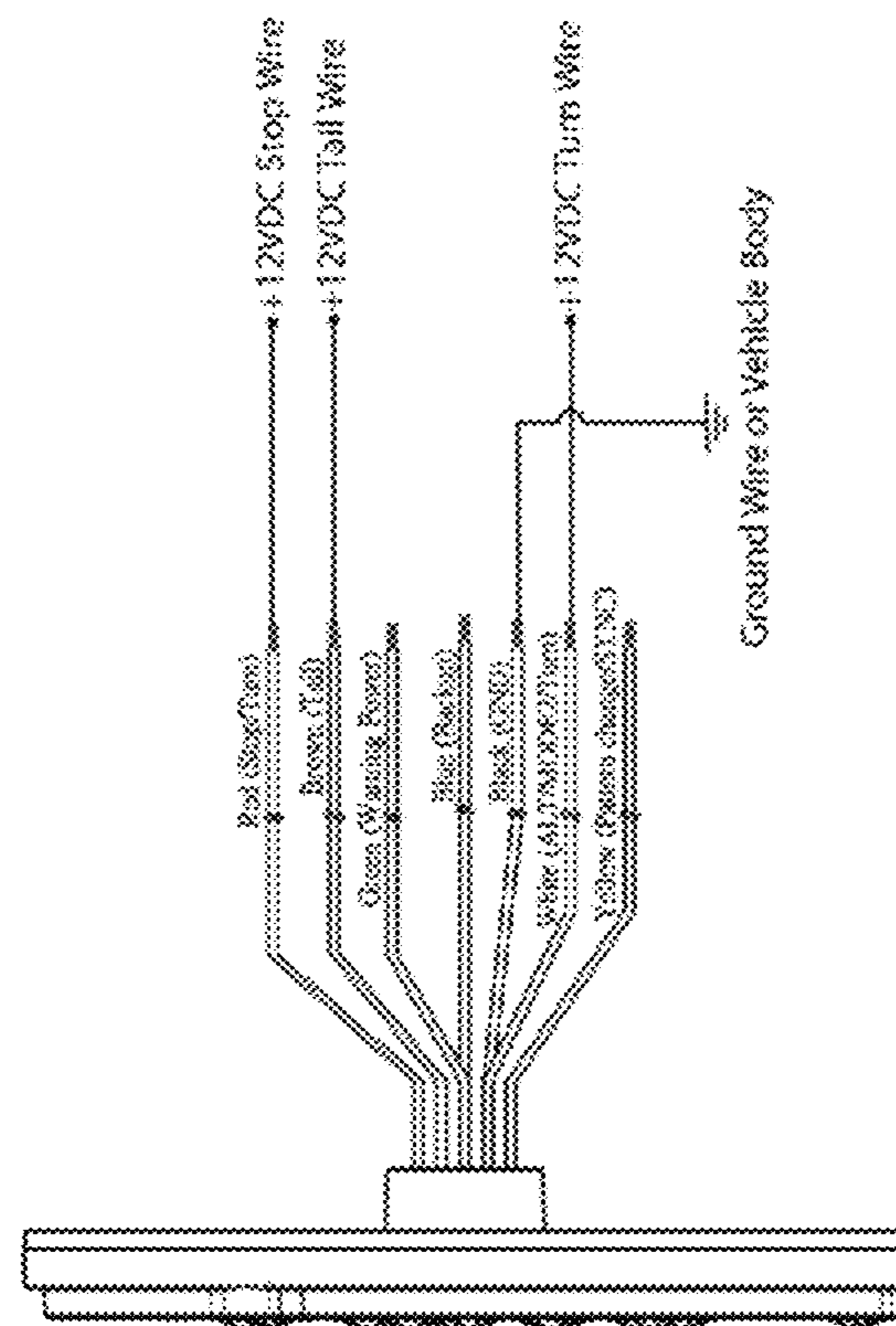

FIG. 34

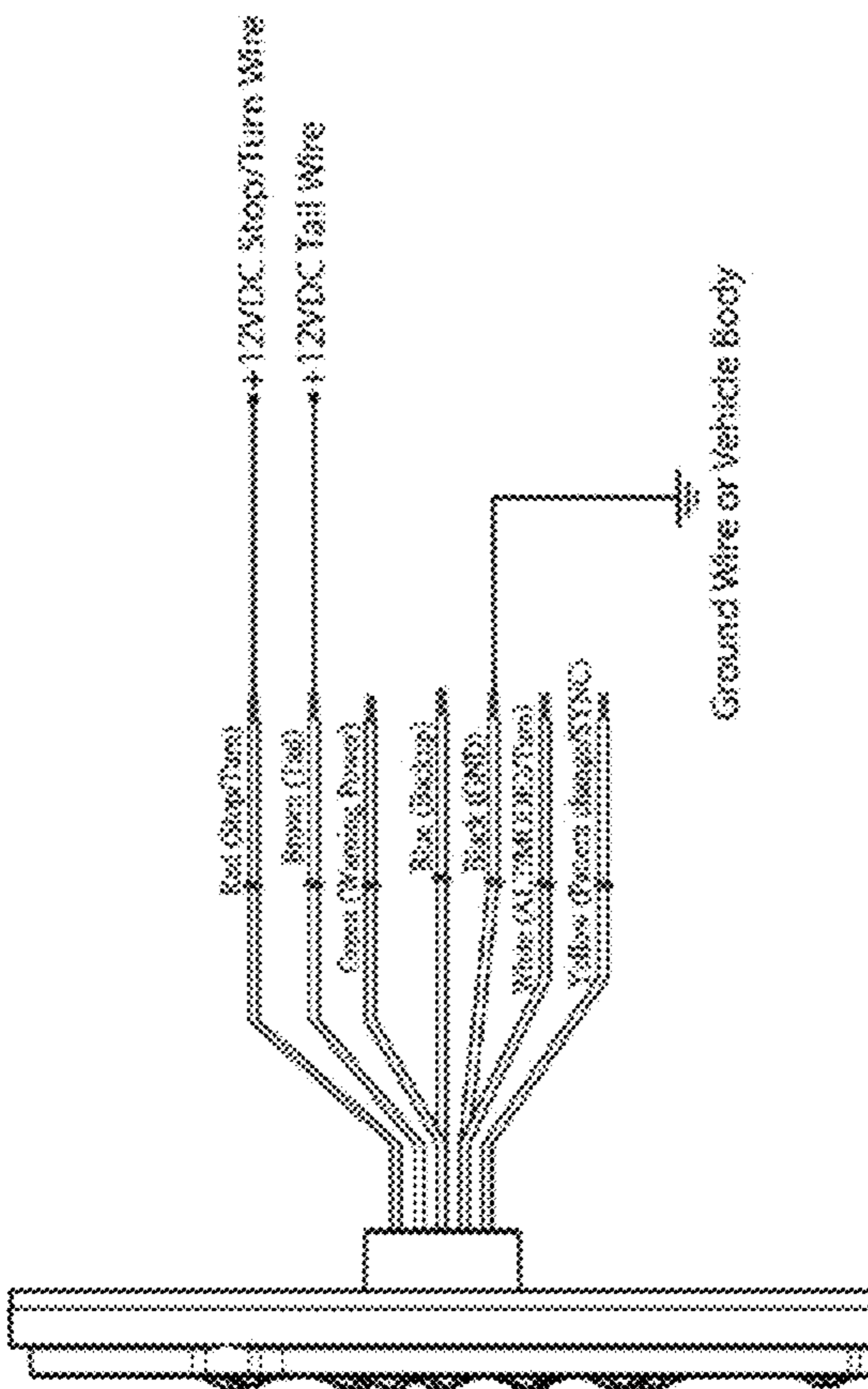

FIG. 35

Pattern #	Description	Function	Yellow	White
0	Random	Dual Color		
1	Steady*	Single Color		
2	Single-Quick	Dual Color		
3	Single	Dual Color		
4	Double	Dual Color		
5	Steady-Double	Dual Color		
6	Quad	Dual Color		
7	Ultra	Dual Color		
8	Mega*	Dual Color		
9	Single-Quad	Dual Color		
10	Single H/L	Dual Color		
11	Single 2 (A/B)	Dual Color	SAE Class 3	
12	Double 2 (A/B)	Dual Color	SAE Class 3	
13	Quad 2 (A/B)	Dual Color	SAE Class 3	
14	Quint	Dual Color		
15	Mega-Separated <sup>1</sup>	Dual Color		
16	Single Pulse <sup>1</sup>	Dual Color		
17	Single-Quick	Single Color		
18	Single	Single Color	SAE Class 1	SAE Class 3
19	Double	Single Color	SAE Class 1	SAE Class 3
20	Triple	Single Color	SAE Class 1	SAE Class 3
21	Quad	Single Color	SAE Class 1	SAE Class 3
22	Ultra	Single Color	SAE Class 2	
23	Quint	Single Color	SAE Class 1	SAE Class 3
24	Mega*	Single Color		
25	Single-Quad	Single Color		
26	Single H/L	Single Color		
27	Single Pulse*	Single Color		
28	Double Pulse*	Single Color		

FIG. 36

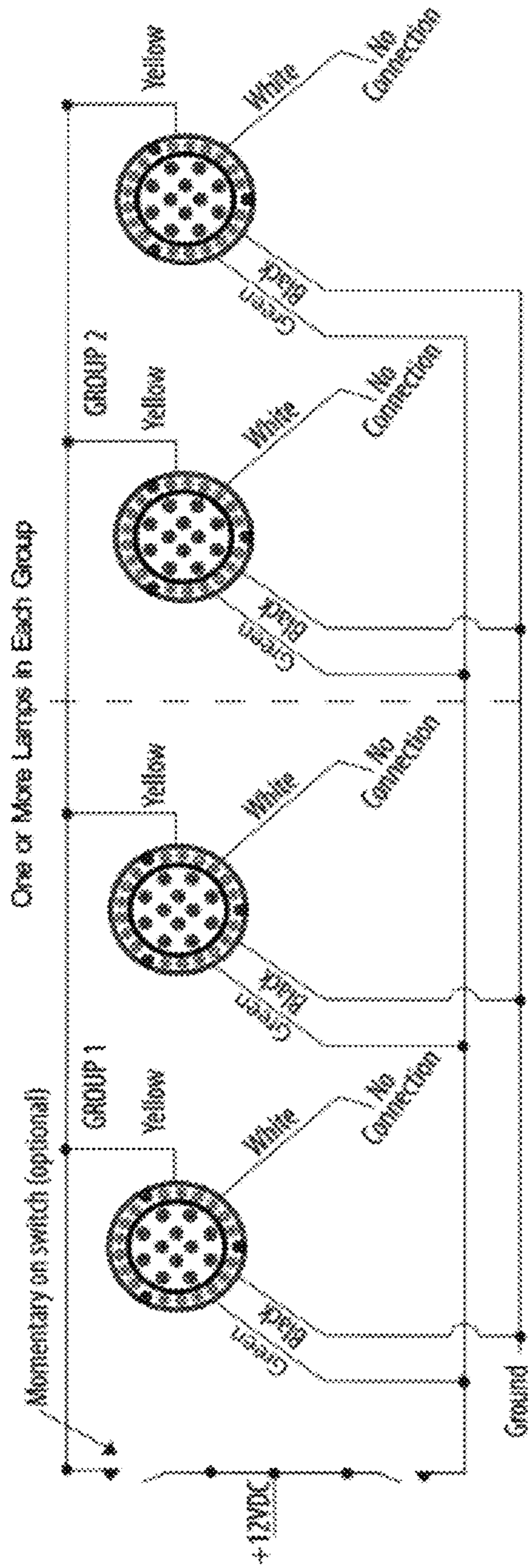

FIG. 37

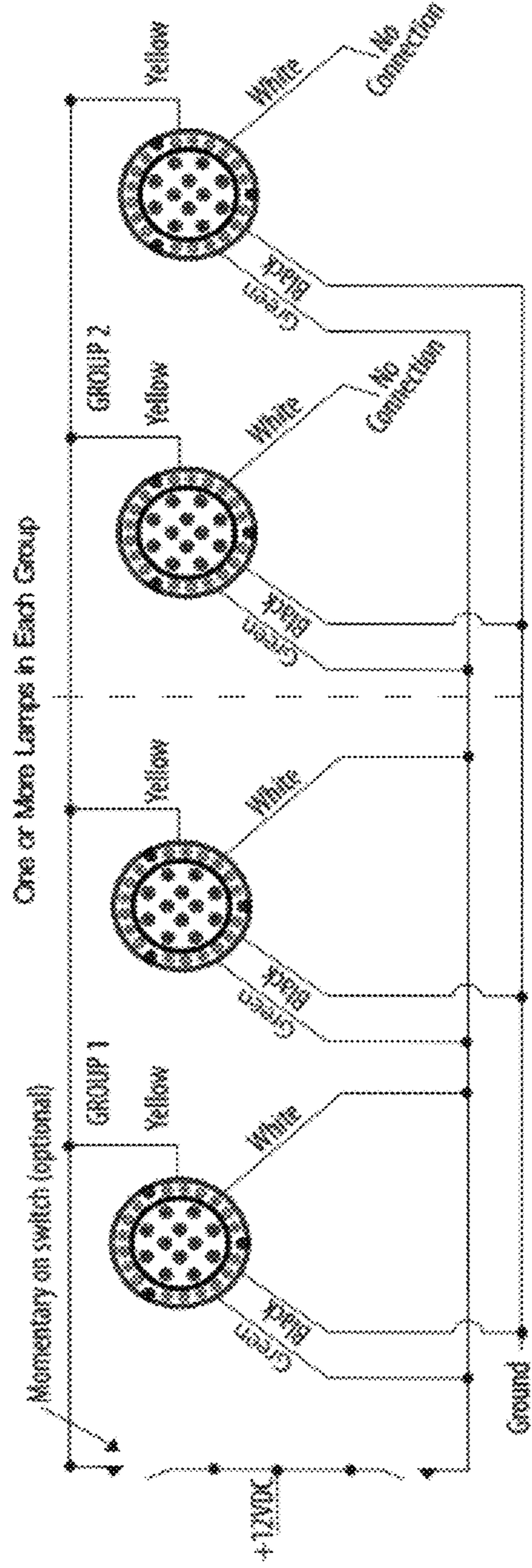

FIG. 38

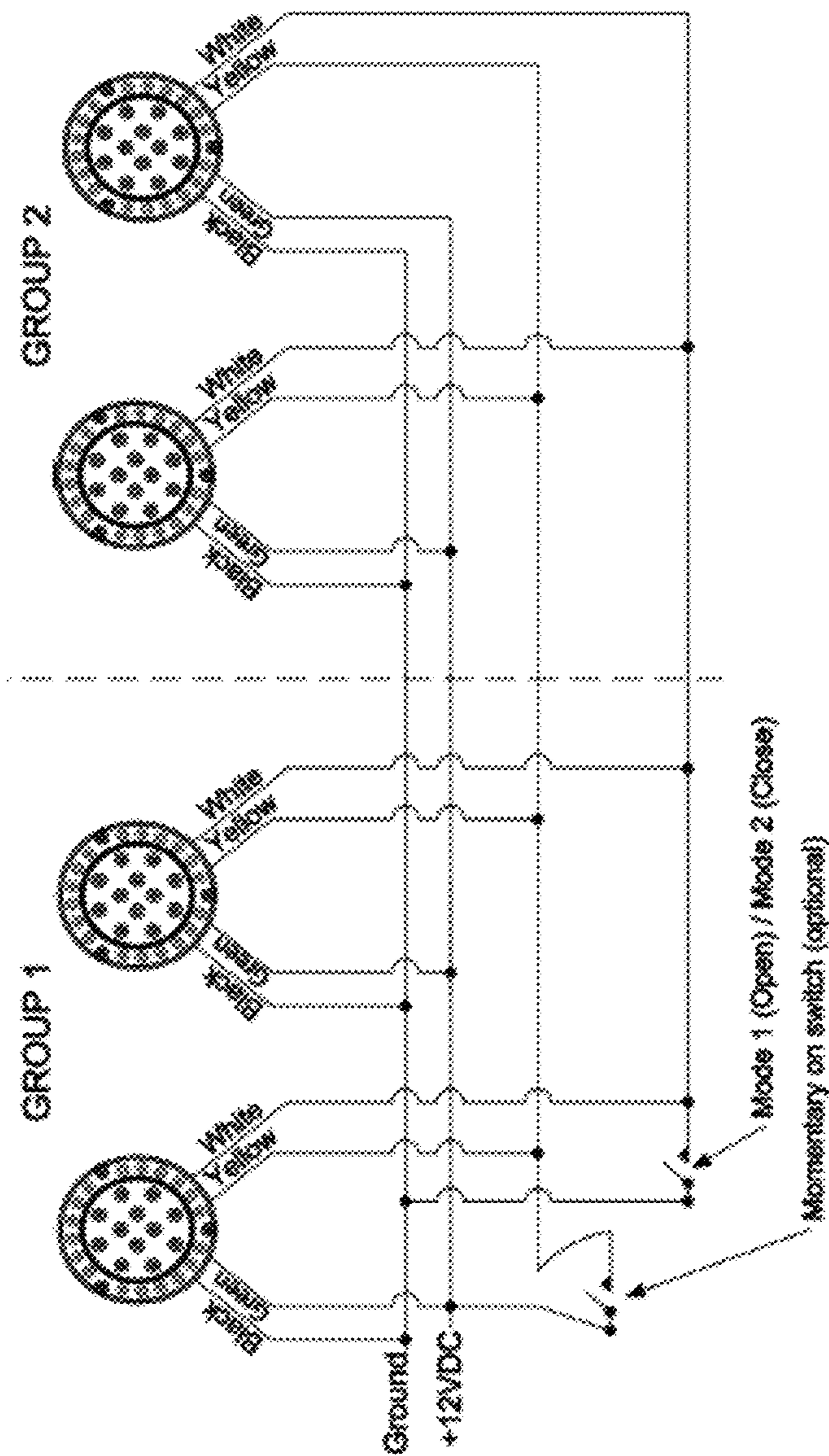

FIG. 39

## 1

## COMBINATION LED LAMPS

## RELATED APPLICATIONS

This application claims the benefit of U.S. Provisional Application No. 63/031,421, filed May 28, 2020, which is incorporated by reference herein in its entirety.

## BACKGROUND

Multiple lamps are often used to illuminate a common area, either in combination or in an alternating fashion. For example, a room can have light fixture such as fluorescent lighting which illuminates the entire room when on, and provides no light when it is off. In addition, the room can have atmosphere lighting which provides a dim illumination. Similarly, the rear of a vehicle can have back-up lamps, which light up when the vehicle is being moved in reverse (or shifted into reverse/back-up), as well as stop/tail/turn lamps, which light up when the driver brakes, signals to turn, or turns on the headlights. These lamps are typically adjacent to each other, and most vehicles have two of each lamp, one on either side of the rear of the vehicle, above the rear bumper. In certain vehicles, such as trucks, it is common to have more than two of the back-up lamp and/or the stop/tail/turn lamp to provide brighter illumination.

## SUMMARY

Various embodiments of a combination lamp are provided, which combine a plurality different lamp functions in a unitary configuration, and can simplify installation and reduce the total amount of space taken up for at least substantially the same amount of illumination produced. The combination lamps can be configured for use on vehicles, light fixtures, free standing lamps, decorative articles, etc. In some embodiments, each lamp component may have a power connection element independent from the other lamp components.

In some embodiments, a combination lamp is provided that includes a stop/turn/tail lamp surrounded by a flange for installation onto a vehicle, wherein the stop/tail/turn lamp and the flange each have a separate set of light sources, preferably comprising one or more light-emitting diodes (LEDs). At least a first portion of the LEDs of the flange are activated when the vehicle backs up, thus performing as a back-up lamp. In some embodiments, the stop/tail/turn lamp and the back-up lamp have separate power plugs connected to the vehicle in such a way that the stop/tail/turn lamp turns on when the driver signals, brakes, or when the headlights are on, and the back-up lamp turns on when the vehicle is backing-up, and not vice-versa.

In some embodiments, at least a second portion of the LEDs of the flange may have a dedicated warning lamp function. The warning lamp may be initiated and energized by a separate set of wires connected to a dedicated switch (on/off). When the warning lamp is in use and the user decides to put the vehicle in back-up, brake (stop), or turn mode, a built-in circuit can automatically cut off the warning function, so that the intense illumination of the warning lamp does not negate the visibility of the lamps used for the back-up, stop, and turn functions.

In some embodiments, in addition to or instead of the warning lamp, a work lamp function may be incorporated. For example, the LEDs of the flange used for the back-up function may be high output LEDs, and a higher output used

## 2

for the work lamp function can be initiated and energized by a set of wires connected to a dedicated switch (on/off).

In some embodiments, the invention provides a combination LED lamp assembly comprising a first lamp in an inner portion of the assembly, having one or more first LEDs and a first power interface; and a flange at least partially surrounding the first lamp, the flange including a second lamp having one or more second LEDs and a second power interface, and a third lamp having one or more third LEDs and a third power interface coupled to a switch, wherein the one or more third LEDs are amber LEDs configured to provide an amber warning lamp function when the switch coupled to the third power interface is turned on.

In some embodiments, the first lamp is a stop/turn/tail lamp and the second lamp is a back-up lamp.

In some embodiments, the second lamp is further configured to provide a white warning lamp function when the switch coupled to the third power interface is turned on.

In some embodiments, the third lamp is further configured to provide an amber turn light.

In some embodiments, the assembly is configured to be mounted on a vehicle.

In some embodiments, the flange includes a plurality of holes and the assembly is configured to be mounted on the vehicle via the holes.

In some embodiments, the first, second, and third lamps are connected to a common power source.

In some embodiments, the assembly further comprises a connector wire coupled to the switch, the connector wire configured to select a flash pattern from a plurality of flash patterns when the switch is turned on.

In some embodiments, the plurality of flash patterns comprise dual color flash patterns and single color flash patterns.

In some embodiments, when a single color flash pattern is selected, the connector wire is further configured to toggle to an alternate color.

In some embodiments, the invention provides a combination LED lamp assembly comprising a first lamp in an inner portion of the assembly, having one or more first LEDs and a first power interface; and a flange at least partially surrounding the first lamp, the flange including a second lamp having one or more second LEDs and a second power interface coupled to a switch, wherein the first lamp is a stop/turn/tail lamp and the second lamp is a back-up lamp and a work lamp, wherein the one or more second LEDs are high output LEDs configured to provide the work lamp function when the switch coupled to the second power interface is turned on.

In some embodiments, the second lamp is configured to provide a light output of about 310 lm when operated as a back-up lamp and about 1,000 lm when operated as a work lamp.

In some embodiments, the assembly is configured to be mounted on a vehicle.

In some embodiments, the flange includes a plurality of holes and the assembly is configured to be mounted on the vehicle via the holes.

In some embodiments, the first and second lamps are connected to a common power source.

Additional features and advantages of embodiments of the present invention are described further below. This summary section is meant merely to illustrate certain features of embodiments of the invention, and is not meant to limit the scope of the invention in any way. The failure to discuss a specific feature or embodiment of the invention, or the

inclusion of one or more features in this summary section, should not be construed to limit the invention as claimed.

#### BRIEF DESCRIPTION OF THE DRAWINGS

The foregoing summary, as well as the following detailed description of certain embodiments of the application, will be better understood when read in conjunction with the appended drawings. For the purposes of illustrating the systems and methods of the present application, there are shown in the drawings preferred embodiments. It should be understood, however, that the application is not limited to the precise arrangements and instrumentalities shown. In the drawings:

FIG. 1 is a front perspective view of an illustrative round combination lamp, according to various embodiments of the present invention;

FIG. 2 is a top plan view of the combination lamp of FIG. 1;

FIG. 3 is a side elevational view of the combination lamp of FIG. 1;

FIG. 4 is a side elevational view of the combination lamp of FIG. 1;

FIG. 5 is a front perspective view of an illustrative oval combination lamp, according to various embodiments of the present invention;

FIG. 6 is a top plan view of the combination lamp of FIG. 5;

FIG. 7 is a side elevational view of the combination lamp of FIG. 5;

FIG. 8 is a side elevational view of the combination lamp of FIG. 5;

FIG. 9 is a front view of four illustrative round combination lamps according to various embodiments of the present invention installed on the rear of a vehicle;

FIG. 10 is a close up view of the two combination lamps on the left side of FIG. 9;

FIG. 11 is an exploded view of an illustrative round combination lamp incorporating a warning lamp in the flange, according to various embodiments of the present invention;

FIG. 12 is a top plan view of an illustrative oval combination lamp incorporating a warning lamp in the flange, according to various embodiments of the present invention;

FIG. 13 is a top plan view of an illustrative round combination lamp, according to various embodiments of the present invention;

FIG. 14 is a side elevational view of the combination lamp of FIG. 13;

FIG. 15 is an exploded view of the combination lamp of FIG. 13;

FIG. 16 is an electrical diagram of the combination lamp of FIG. 13;

FIG. 17 is a top plan view of an illustrative round combination lamp incorporating a work lamp in the flange, according to various embodiments of the present invention;

FIG. 18 is a side elevational view of the combination lamp of FIG. 17;

FIG. 19 is an exploded view of the combination lamp of FIG. 17;

FIG. 20 is an electrical diagram of the combination lamp of FIG. 17;

FIG. 21 is a front perspective view of an illustrative round combination lamp incorporating a warning lamp in the flange, according to various embodiments of the present invention;

FIG. 22 is a top plan view of the combination lamp of FIG. 21;

FIG. 23 is a bottom plan view of the combination lamp of FIG. 21;

FIG. 24 is a side elevational view of the combination lamp of FIG. 21;

FIG. 25 is an exploded view of the combination lamp of FIG. 21;

FIG. 26 is an electrical diagram of the combination lamp of FIG. 21;

FIGS. 27-30 show the combination lamp of FIG. 21 in different operational modes;

FIG. 31 shows a schematic of the combination lamp of FIG. 17 installed on the rear of a vehicle;

FIG. 32 shows a schematic of the combination lamp of FIG. 21 installed on the rear of a vehicle;

FIG. 33 shows a schematic of the electrical diagram of FIG. 26, with functional sections labeled;

FIG. 34 shows the view of FIG. 24 with 3-Wire Stop/Turn/Tail wiring;

FIG. 35 shows the view of FIG. 24 with 4-Wire Stop/Turn/Tail wiring;

FIG. 36 shows examples of different flash patterns for the warning lamp component of the combination lamp of FIG. 21;

FIG. 37 shows illustrative warning wiring instructions for simultaneous flash;

FIG. 38 shows illustrative warning wiring instructions for alternate flash; and

FIG. 39 shows illustrative warning wiring instructions for an optional warning Mode 2.

#### DETAILED DESCRIPTION

Certain illustrative embodiments of the present invention will now be described with reference to the drawings. In general, such embodiments relate to a combination lamp comprising at least two different sets of light sources, wherein each set of light sources can be activated independently from the other sets of light sources.

Referring to FIGS. 1-8, certain embodiments of a combination lamp 10, 30 can comprise a first lamp 100, 300 and a second lamp 200, 400 in a fixed relationship with each other. See, e.g., U.S. Pat. No. 8,052,313, which is incorporated by reference herein in its entirety. Whereas combination lamp 10 shown in FIGS. 1-4 comprises a generally round shape and combination lamp 30 shown in FIGS. 5-8 comprises a generally oval shape, it is to be understood that a combination lamp constructed in accordance with the invention can take on any shape as a matter specific to an application or a matter of design choice.

As shown, first lamp 100, 300 can have a plurality of LEDs 101, 301 mounted on a first support 102, 302, preferably covered by a first lens 103, 303. Second lamp 200, 400 can comprise a plurality of LEDs 201, 401 mounted on a second support 202, 402, preferably covered by a second lens 203, 403. First lamp 100, 300 and second lamp 200, 400 can be constructed and arranged to be selectively removable from or permanently fixed to each other, as a matter specific to an application or a matter of design choice. Preferably, first support 102, 302 connects to second support 202, 402 to secure the first lamp 100, 300 and second lamp 200, 400 together. Additionally, second support 202, 402 preferably includes a mounting element 210, 410 for mounting second lamp 200, 400 and preferably combination lamp 10, 30 onto a surface, such as on a vehicle.



Referring to FIGS. 1-4, in accordance with certain uses of embodiments of the invention, such as outdoor use, especially on vehicles, it may be preferable for first support **102** to be permanently fixed to second support **202**, to provide security. In accordance with various embodiments of the invention, second lamp **200** can be directly mounted on a surface, such as a vehicle body, and first lamp **100** can be connected to second lamp **200**, which can maintain first lamp **100** in place. Certain illustrative embodiments include a second lamp **200** that comprises a flange for mounting on the rear of a vehicle. Second lamp **200** can thus be secured to the vehicle, and first lamp **100** can be connected to second lamp **200** by way of non-limiting example, by being inserted into a receiving aperture in second lamp **200**. In accordance with certain illustrative embodiments of the invention, first lamp **100** can be inserted into the receiving aperture of second lamp **200** until it snaps into place, after which first lamp **100** cannot be removed.

Alternatively, referring to FIG. 2 by way of non-limiting example, it may be desirable for first lamp **100** to be separable from second lamp **200**. Such removability can facilitate quick and easy replacement of lamps **100** or parts thereof. For example, one can remove first lamp **100** from second lamp **200**, replace the necessary LEDs, fix the circuitry, replace the lens, etc., whatever service is desired, then put first lamp **100** back in place. Alternatively, a replacement lamp can be put in place while first lamp **100** is serviced. Whereas first lamp **100** has been described as being inserted into and removed from second lamp **200**, it is to be understood that second lamp **200** can be inserted into or removed from first lamp **100**, without deviating from the scope of the invention.

The use of LEDs has been increasing recently, which may be partially because they can have an operating life of up to 100,000 hours before degradation commences. Therefore, an LED typically has greater operating life than a standard high-intensity incandescent bulb, which has a relatively short life span and is susceptible to damage. Furthermore, LEDs are commonly smaller in size than light bulbs, and provide more flexibility in positioning. Therefore, it can be preferable for combination lamp **10** to comprise LEDs in both lamps **100**, **200**. When used on a vehicle, the illumination provided by the LEDs preferably meets the appropriate DOT (Department of Transportation) standards. For example, if combination lamp **10** includes an amber LED lamp as first lamp **100** and is to be used on the front of a vehicle, the amber LED lamp preferably meets the full turn compliance standards. Preferably, second lamp **200** meets the DRL (Daytime Running Light) standards, which would permit it to be used as a DRL lamp, which the DOT has encouraged as enhancing safety by elevating the visibility and noticeability of moving vehicles. Second lamp **200** need not meet the DRL standards, however, if it is being used for other purposes, such as for a decorative use.

Depending on the desired use of combination lamp **10**, the number and positioning of LEDs per lamp **100**, **200** can be varied. For example, whereas FIGS. 2 and 6 show certain embodiments of combination lamp **10**, **30** wherein first lamp **100**, **300** has nine LEDs and second lamp **200**, **400** has eighteen LEDs, it is to be understood that the number of LEDs in each lamp can vary as a matter specific to an application or a matter of design choice.

In accordance with the embodiments shown in FIGS. 3 and 7, first lamp **100**, **300** comprises a plurality of projections **104**, **304** on first lens **103**, **303** located above LEDs **101**, **301**. These projections **104**, **304** are preferably constructed and arranged to disperse light emitted from the LED

below it, for example, by changing the direction of the emitted light. See, e.g., U.S. Pat. Nos. 8,009,364 and 8,717,679, which are incorporated by reference herein in their entirety. Whereas FIGS. 3 and 7 show second lamp **200**, **400** without projections, it is to be understood that second lamp **200**, **400** can also include projections, which can be similar or different from projections **104**, **304** of first lamp **100**, **300**. Combination lamp **10**, **30** can have any combination of lamps having projections, and first lamp **100**, **300** and second lamp **200**, **400** can have any number of projections without deviating from the scope of the invention.

In accordance with various embodiments of the invention, as illustrated in FIG. 8, each lamp **300**, **400** may have its own power connection **31**, **32**, such as a plug, outlet, or any mechanism for connecting to a power source. Power connections **31**, **32** can either connect to the same or separate power sources. Accordingly, each lamp **300**, **400** can be turned on or off or otherwise controlled independently of the another. For example, if combination lamp **30** as shown in FIGS. 5-8 is used on a vehicle, wherein first lamp **300** is a stop/tail/turn lamp and second lamp **400** is a back-up lamp, first lamp **300** will light up when the driver of the vehicle signals or stops, while second lamp **400** can remain off. On the other hand, when the driver backs up, first lamp **300** can remain off while second lamp **400** is lit. Alternatively, first lamp **300** can be a back-up lamp and second lamp **400** could be a stop/tail/turn lamp without deviating from the scope of the invention.

When used in a vehicle, it can be preferable for each first lamp **300** and second lamp **400** to be connected to the power source via separate cables. For example, the vehicles can have two cords for each lamp aperture or mount on which a combination lamp can be mounted. However, it is possible for one cord to be provided for each aperture/mount, wherein the power from each cord is split with a splitter or similar component, ends of the splitter being connected to one of the first connection of first lamp **300** or the second connection of second lamp **400**. This is particularly suitable for vehicles that were built to house only one lamp in each aperture/mount.

One potential benefit in using a combination lamp in accordance with embodiments of the invention with vehicles (e.g., work trucks produced for use in industries such as, but not limited to, cable, plumbing, electrical, etc.) is that more light can be provided. For example, because the combination lamp **10**, **30** occupies only one aperture/mount that one conventional stop/tail/turn or back-up lamp would occupy on the rear of the vehicle, one aperture/mount becomes free. One possible use of the freed aperture/mount is to mount an additional combination lamp, thus providing a total of four stop/tail/turn lamps and four back-up lamps (see, e.g., FIGS. 9 and 10) while occupying the same space as two of each of the conventional lamps. Therefore, the illumination provided for each action of braking, signaling to turn, backing-up, etc. can be doubled. Alternatively, a conventional stop/tail/turn lamp or back-up lamp (or other type lamp, such as a warning lamp or work lamp) may be mounted in combination with combination lamp **10**, **30** thus providing extra illumination for specific actions.

Furthermore, combination lamp **10**, **30** is preferably not significantly larger than a conventional stop/tail/turn or back-up lamp. For example, a conventional lamp for a vehicle, particularly trucks, is commonly mounted on a separate, dedicated mounting flange which is then mounted on the vehicle. Alternatively, a separate, dedicated mounting flange can be mounted first onto a vehicle, and a lamp can be subsequently mounted thereon. Another embodiment

provides a lamp that is integrally formed with a dedicated mounting flange which is mounted on the vehicle. Thus, in accordance with the conventional lamps, both a lamp and a dedicated mounting flange structure are required. According to various embodiments of the present invention, the flange used for mounting can comprise one of the lamp components of a combination lamp. For example, referring to FIG. 2, second lamp 200 can comprise a flange which is mounted on the vehicle. Therefore, no substantive structure is being added in such an embodiment (the second lamp 200 occupying approximately the same space as the dedicated mounting flange used with a conventional lamp), and the space can be maximized.

In accordance with embodiments of the invention as shown in FIGS. 1-8, a combination lamp 10, 30 preferably includes at least two sets of light sources, one of which surrounds the other. As shown, second lamp 200, 400 surrounds the perimeter of first lamp 100, 300. Such an arrangement can be particularly beneficial for use as a vehicle stop/tail/turn-back-up combination lamp (see also FIGS. 13-16 described further below) or a DRL-amber combination lamp, thus maintaining the shape of the illumination consistent with standard stop/tail/turn, back-up, or amber lamps, and more particularly, when applicable, maintaining the flange-lamp arrangement consistent with conventional flanges and lamps.

First lamp 100, 300 and second lamp 200, 400 of a combination lamp 10, 30 in accordance with embodiments of the invention that are not mounted on a vehicle can also be connected to a common power source via a splitter or separate cords. Alternatively, first lamp 100, 300 and second lamp 200, 400 can be connected to different power sources entirely. Furthermore, second lamp 200, 400 need not surround first lamp 100, 300, but may be positioned side-by-side, intertwined, create a design with, etc., without deviating from the scope of the invention, as a matter specific to an application or a matter of design choice.

Another potential use of embodiments of the invention includes hallways, staircases, and the like, where it can be preferable to provide more than one type of illumination. For example, a dim light can remain on constantly, whereas a bright light can be turned on and off. In accordance with certain illustrative embodiments, second lamp 200, 400 can provide a low, dim light, such as a night light, and have a light sensor and only turns on when there is insufficient light present in the area. The first lamp 100, 300, in contrast, can provide brighter illumination, but is configured to be turned on and off by a user. By providing a combination lamp, the same area can be used for two different types and sources of light.

Combination LED lamps according to embodiments of the present invention can comprise various shapes and sizes, and further can be utilized at a variety of locations for a variety of functions without deviating from the scope of the invention, as a matter specific to an application or a matter of design choice. Additionally, other alterations can be made, such as, but not limited to, varying the number of LEDs, altering the transparency of the lenses, the shape and size of the supports, number, shape and/or size of the projections, etc. as a matter specific to an application or a matter of design choice, without deviating from the scope of the invention.

In various embodiments of the present invention, a combination lamp 10, 30 may be provided that has an appearance substantially as shown in FIGS. 1-8, but wherein the LEDs 201, 401 in the flange are higher output LEDs (e.g., higher power, higher luminosity compared to standard

LEDs), and a more intense illumination thereof can provide a separate, third lamp function. When LEDs 201, 401 are embodied as higher output LEDs, for example, they can provide a work lamp function as well as a back-up lamp function. The higher output LEDs can be initiated and energized by a set of wires connected to a dedicated switch (on/off). When the switch is in an "off" position, LEDs 201, 401 may function as a back-up lamp providing typical back-up illumination as described above. When the switch is in an "on" position, the higher output may be engaged, and LEDs 201, 401 may function as work lamp providing brighter illumination in the back of the vehicle. In some embodiments, higher output LEDs 201, 401 may be mounted on an aluminum PCB, for example, to accommodate the increased amount of heat produced.

In various other embodiments of the present invention, a combination lamp 10, 30 may be provided that utilizes different colors for different functions in the flange. With reference to FIGS. 11 and 12, for example, in various embodiments, a combination lamp 10, 30 may be provided which incorporates an emergency warning lamp 800, 900 into the flange. FIG. 11 shows an exploded view of an illustrative round combination lamp 10 with multiple functions, and FIG. 12 shows a top plan view of an illustrative oval combination lamp 30 with multiple functions. The combination lamp of FIG. 11 is similar to the combination lamp shown in FIGS. 1-4, and the combination lamp of FIG. 12 is similar to the combination lamp shown in FIGS. 5-8; however, a combination lamp 10, 30 as shown in FIGS. 11, 12 combines at least three different lamp components in a unitary configuration, and is configured such that a first portion of the LEDs of the flange comprise LEDs 201, 401 with one function (e.g., back-up lighting) while a second portion of the LEDs of the flange comprise LEDs 801, 901 with a separate function (and/or color) (e.g., a dedicated warning lamp function). LEDs 801, 901 may be a different color (e.g., amber) from LEDs 201, 401 (e.g., white), distinguishable through a clear lens 203, 403. The LEDs 101, 301 in the center area provide a third function (e.g., stop/tail/turn). LEDs 101, 301 may be white, covered by a colored (e.g., red) lens, or may be colored (e.g., red) LEDs covered by either a clear or colored (e.g., red) lens. The embodiments of combination lamp 10, 30 shown FIGS. 11 and 12 are illustrated with eight LEDs 801 and six LEDs 901, respectively, but different numbers and/or positions of LEDs 801, 901 on the flange can be used for the second function of the flange as a matter specific to an application or a matter of design choice. See also FIGS. 21-30 described further below.

The warning lamp 800, 900 may be initiated and energized by a separate (dedicated) set of wires connected to a dedicated switch (on/off). When the warning lamp 800, 900 is in use and the user decides to put the vehicle in back-up, brake (stop), or turn mode, a built-in circuit can automatically cut off the warning function, so that the intense illumination of the warning flashes does not negate the visibility of the lamp 200, 400 used for the back-up function and/or the lamp 100, 300 used for the stop/tail/turn function. In some embodiments, the amber (or other color) warning light is configured to flash unless the user chooses to install a switch to employ a steady illumination. In various embodiments, a separate set of wires can initiate the warning function. In some embodiments, where two or more combination lamps incorporating warning lamps are provided, an auxiliary wire can alternate between the different warning lamps. For example, when the auxiliary wire is connected,

a user can sync the flashing of two or more warning lamps so that they flash simultaneously, alternately, have different patterns of flashing, etc.

In various embodiments, a combination lamp **10**, **30** may be provided which has an appearance substantially as in FIGS. **11**, **12**, but also incorporates a work lamp into the flange, thus providing four functions (e.g., stop/turn/tail, back-up, warning lamp, and work lamp). For example, the LEDs **201**, **401** of the flange used for the back-up function may be high output LEDs, which can be initiated and energized by a set of wires connected to a dedicated switch (on/off). In these embodiments, when the switch is off, LEDs **201**, **401** can provide a standard back-up function as described above; and when the switch is turned on, LEDs **201**, **401** can provide more intense lighting (e.g., for working on the side of the road). Warning LEDs **801**, **901** have separate dedicated wiring connected to a dedicated switch as described above.

FIGS. **13-16** show top plan, side elevational, and exploded views and an electrical diagram of an illustrative combination lamp according to various embodiments of the invention. Dimensions marked are in mm. This combination lamp **10** embodiment (Maxxima M85417R) is a 5.5" round hybrid combination stop turn tail and back-up light, comprising a 4" round red stop turn tail (S/T/T) lamp **100** and 5.5" back-up (BU) flange **200** having 12 red LEDs **101** and nine white LEDs **201**, respectively, mounted on support **502** (PCB) with back cover/housing **505** and neoprene gasket **506** with holes **511** attached. Lens **103** covering LEDs **101** may be colored (e.g., red) and may include projections **104** as described above. Lens **203** covering LEDs **201** may be clear and may include projections **204** as described above and holes **205** for mounting. Lens **103** and lens **203** may be secured to or integrally formed with one another. The combination lamp of FIGS. **13-16** may include mounting screws **507** (see FIG. **21**) and screw caps (mounting screw covers) **508**, and has a thin profile, sealed moisture proof electronics, and polycarbonate lens and housing components. Plastic screw caps/covers/inserts **508** can be pressed onto the screw holes **511** after the combination lamp **10** is installed on the vehicle, and can make the combination lamp **10** tamper resistant. In some embodiments, screw caps **508** are configured such that they cannot be removed once they are installed. In some embodiments, the combination lamp of FIGS. **13-16** may be provided as a kit, including two female PL3 connectors **509**. In illustrative embodiments, the specifications for the combination lamp of FIGS. **13-16** are as follows: LEDs—21 (12 Red, 9 White); Voltage—12.8 VDC; Amp Draw—BU 0.2 A, Tail 20 mA, Stop 0.2 A; Dimensions—5.5" Diameter×0.5" Depth; Mounting—3-Hole Flange Mount (3)  $\frac{3}{16}$ " holes, Hole cutouts:  $1\frac{3}{16}$ " for cable exit; Connector—(2) PL3 Female, 10" Wire; DOT/SAE—J593, J2040, J2261.

FIGS. **17-20** show top plan, side elevational, and exploded views and an electrical diagram of another illustrative combination lamp according to various embodiments of the invention. Dimensions marked are in mm. This combination lamp **10** embodiment (Maxxima M85437R-WL) is a 5.5" round hybrid combination stop turn tail and back-up and work light, comprising a 4" round red stop turn tail (S/T/T) lamp **100** and 5.5" back-up (BU) flange **200** having 12 red LEDs **101** and nine white LEDs **201**, respectively, mounted on support **502** (PCB) with back cover/housing **505** and neoprene gasket **506** with holes **511** attached, where LEDs **201** are embodied as higher output LEDs as described above. Lens **103** covering LEDs **101** may be colored (e.g., red) and may include projections **104** as

described above. Lens **203** covering the higher output LEDs **201** may be clear and may include projections **204** as described above and holes **205** for mounting. Lens **103** and lens **203** may be secured to or integrally formed with one another. The combination lamp of FIGS. **17-20** may include mounting screws **507** (see FIG. **21**) and screw caps (mounting screw covers) **508**, and has a thin profile, sealed moisture proof electronics, and polycarbonate lens and housing components. Plastic screw caps/covers/inserts **508** can be pressed onto the screw holes **511** after the combination lamp **10** is installed on the vehicle, and can make the combination lamp **10** tamper resistant. In some embodiments, screw caps **508** are configured such that they cannot be removed once they are installed. Connector leads **510** (e.g., five blunt cut wires) may be color coded, for example, as follows: red (stop/turn), brown (tail), blue (back-up), black (ground), white (work light). In illustrative embodiments, the specifications for the combination lamp of FIGS. **17-20** are as follows: LEDs—21 (12 Red, 9 White); Voltage—12.8 VDC; Amp Draw—BU 0.2 A, Tail 20 mA, Stop 0.2 A, WL 1.0 A; Dimensions—5.5" Diameter×0.5" Depth; Mounting—3-Hole Flange Mount (3)  $\frac{3}{16}$ " holes, Hole cutouts:  $1\frac{3}{16}$ " for cable exit; Connector—5 Leads Blunt Cut 10"; DOT/SAE—J593, J2040, J2261. The combination lamp of FIGS. **17-20** incorporates a dual function flange back-up light and work light configured to provide, for example, 310 lumen back-up light/1,000 lumen work light (WL).

FIGS. **21-26** show front perspective, top plan, bottom plan, side elevational, and exploded views and an electrical diagram of another illustrative combination lamp according to various embodiments of the invention. Dimensions marked are in mm. This combination lamp **10** embodiment (Maxxima M85427R-YCL) is a 5.5" round hybrid combination stop turn tail and back-up and flashing warning light (single color nine LED or dual color 18 LED), comprising a 4" round red stop turn tail (S/T/T) lamp **100** having 12 red LEDs **101**, and a 5.5" back-up (BU) flange **200/800** having nine white LEDs **201** (back-up and warning) and nine amber LEDs **801** (warning and turn), mounted on support **502** (PCB) with back cover/housing **505** and neoprene gasket **506** with holes **511** attached. As shown, the nine white LEDs **201** and nine amber LEDs **801** alternate one-by-one around the flange; however, in other embodiments, LEDs **201**, **801** may be provided in different numbers and/or arrangements/groupings around the flange (see, e.g., FIGS. **11**, **12**). Lens **103** covering LEDs **101** may be colored (e.g., red) and may include projections **104** as described above. Lens **203** covering LEDs **201**, **801** may be clear and may have a substantially smooth exterior as shown (though alternative embodiments may include projections **204** as described above) and holes **205** for mounting. Lens **103** and lens **203** may be secured to or integrally formed with one another. The combination lamp of FIGS. **21-26** may include mounting screws **507** and screw caps (mounting screw covers) **508**; has a thin profile, sealed moisture proof electronics, and polycarbonate lens and housing components; and is DOT FMVSS108/CMVSS1088 compliant. Plastic screw caps/covers/inserts **508** can be pressed onto the screw holes **511** after the combination lamp **10** is installed on the vehicle, and can make the combination lamp **10** tamper resistant. In some embodiments, screw caps **508** are configured such that they cannot be removed once they are installed. Connector leads **510** (e.g., seven blunt cut wires) may be color coded, for example, as follows: red (stop/turn), brown (tail), green (warning power), blue (back-up), black (ground), white (ALT/MODE2/turn), yellow (pattern change/SYNC). In illustrative embodiments, the specifications for the combi-

## 11

nation lamp of FIGS. 21-26 are as follows: LEDs—30 (12 Red, 9 White, 9 Amber); Voltage—12.8 VDC; Amp Draw—0.6 A Max Amp (Stop+Warn), BU 0.2 A, Tail 20 mA, Stop 0.2 A, Amber Turn 100 mA, Warn 0.4 A; Dimensions—5.5" Diameter×0.5" Depth; Mounting—3-Hole Flange Mount (3) 5  
 3/16" holes, Hole cutouts: 1 3/16" for cable exit; Connector—7 Leads Blunt Cut 10"; DOT/SAE—J593, J2040, J2261, J595. The combination lamp of FIGS. 21-26 provides an all-in-one S/T/T and Back-Up and Dual Color Amber White Flashing Warning (SAE J595 Class 1 Warning Device), 10  
 which can flash amber only, white only, or amber/white dual color. An amber turn may be provided for trucks with a dedicated turn wire (4-wire S/T/T circuit; see FIG. 35). FIGS. 27 and 28 show the combination lamp of FIGS. 21-26 with 12 red LEDs 101 providing tail light and stop light, 15  
 respectively. FIG. 29 shows the combination lamp of FIGS. 21-26 with nine white LEDs 201 providing back-up light. FIG. 30 shows the combination lamp of FIGS. 21-26 with nine amber LEDs 801 providing flashing amber warning light. In various embodiments, LEDs 101 may also provide 20  
 an optional red turn; LEDs 201 may also provide an optional flashing white warning; LEDs 801 may also provide an optional amber turn. FIG. 33 shows a schematic of the electrical diagram of FIG. 26, indicating sections for input/output power management, microcontroller, red lens section for red stop/tail/turn, white LEDs in outer circle section used for back-up and warning, and amber LEDs in outer circle section used for warning and amber turn.

In various embodiments, the wiring designations for the illustrative round hybrid combination S/T/T-BU-Warning lamp 10 of FIGS. 21-16 may be, for example, as follows: black—ground (-); brown—tail (+VDC); blue—back-up (+VDC); red—stop and turn (+VDC); white—optional amber turn (+VDC), optional warning ‘Mode 2’ (-GND); green—flashing warning (+VDC); yellow—programming (+VDC), described in further detail below. In various 35  
 embodiments, the wiring instructions may be as follows. First, determine if the vehicle has a dedicated turn signal wire or uses a common wire for both stop light and turn signal. FIG. 34 shows 3-Wire Stop/Turn/Tail wiring (red turn signal). If the vehicle uses a common wire for both stop light and turn signal, use the Red Turn Signal by connecting the Red Wire. FIG. 35 shows 4-Wire Stop/Turn/Tail wiring (amber turn signal). If the vehicle has dedicated Left and Right Turn Signal wires, independent of the Stop Light, use 40  
 the optional Amber Turn Signal by connecting the White Wire. Then follow steps 1-7. Step 1—Connect Black wire to vehicle Ground (- Negative). Step 2—Connect Brown wire to vehicle Tail Light (+12V). Step 3—Connect Red wire to vehicle Stop Light (+12V). Step 4 (Optional)—Connect White wire to vehicle Left or Right Turn Signal (+12V). Step 5—Connect Blue wire to vehicle Back-up Light (+12V). Step 6—Connect Green wire “Flashing Warning Circuit” via a user-supplied switch (+12V). Step 7—Program Warning to the desired pattern with Yellow wire. While 55  
 the Green wire is connected to +12V, Hold Yellow wire to +12V for 1 to 2 seconds to scroll to the next flash pattern (See Table 1). If on a Single-Color pattern, Hold Yellow wire for 3 to 5 sec to toggle to the alternate color (i.e. from Amber to White). To reset to Pattern #1, Hold Yellow wire to +12V 60  
 for 7+ seconds. FIG. 36 shows 28 illustrative flash patterns; however, in other embodiments, different numbers and/or types of flash patterns may be provided. In FIG. 36, an asterisk=no alternate function available, and superscript ‘1’=alternate between colors. Step 8—“Simultaneous Flash” or “Alternate Flash” may be selected. FIG. 37 shows warning wiring instructions for simultaneous flash. FIG. 38

## 12

shows warning wiring instructions for alternate flash (Group 1 will flash the set pattern alternatively with Group 2). To flash all lamps synchronously, join all yellow wires together. This allows the lights to communicate with each other. To use alternate or “wig-wag” flash, identify lamps in “Group 1” and “Group 2”; Connect White wires in “Group 1” to +12V. (In some embodiments, the Optional Amber Turn Signal may be disabled when the Flashing Warning light is on and/or activating the Back-up may disable the Warning light. In other embodiments, the combination lamp may be configured to enter a different Backup/Warning mode.) Step 9 (Optional)—To use the optional “Mode 2” Flashing Warning pattern, a DPDT (double-pole, double-throw) switch is needed. See the diagram in FIG. 39. To access Secondary Mode, or second flash pattern, Connect Green to +12V and White to (-) Ground. While in Mode 2, use Yellow wire (+12V) to program the desired flash pattern (step 7). Mode 1: Leave the switch open and select first pattern. Mode 2: Close the switch and select second flash pattern. Users can toggle between the two selected flash patterns by changing the switch position. A DPDT switch is needed to use an alternate mode of operation in Primary Mode (Mode 1). Connect Group 2 separately to the other pole switch (common side). The switch other two side should be +12V (alt) and Ground (Mode 2). For single color patterns, connect Yellow wires to +12 VDC (Green wire) for 3 to 5 seconds to change the color.

While there have been shown and described fundamental novel features of the invention as applied to the preferred and illustrative embodiments thereof, it will be understood that omissions and substitutions and changes in the form and details of the disclosed invention may be made by those skilled in the art without departing from the spirit of the invention. Moreover, as is readily apparent, numerous modifications and changes may readily occur to those skilled in the art. For example, various features and structures of the different embodiments discussed herein may be combined and interchanged. Hence, it is not desired to limit the invention to the exact construction and operation shown and described and, accordingly, all suitable modification equivalents may be resorted to falling within the scope of the invention as claimed. It is the intention, therefore, to be limited only as indicated by the scope of the claims appended hereto.

The invention claimed is:

1. A combination LED lamp assembly comprising:
  - a first lamp in an inner portion of the assembly, having one or more first LEDs and a first power interface; and
  - a flange at least partially surrounding the first lamp, the flange including a second lamp having one or more second LEDs and a second power interface and a third lamp having one or more third LEDs and a third power interface coupled to a switch,
 wherein the first lamp is a stop/turn/tail lamp and the second lamp is a back-up lamp, and
  - wherein the one or more third LEDs are amber LEDs and the flange including the second lamp and the third lamp is configured to provide a dual color amber white flashing warning lamp function when the switch coupled to the third power interface is turned on,
  - wherein the assembly includes a connector wire configured to select a flash pattern from a plurality of flash patterns when the switch is turned on, wherein the plurality of flash patterns comprise dual color flash patterns and single color flash patterns, and wherein when a single color flash pattern is selected, the connector wire is further configured to toggle to an alter-

**13**

- nate color, thereby enabling the flange to flash amber only, white only, or amber and white.
2. The assembly of claim 1, wherein the third lamp is further configured to provide an amber turn light.
3. The assembly of claim 1, wherein the assembly is 5 configured to be mounted on a vehicle.
4. The assembly of claim 3, wherein the flange includes a plurality of holes and the assembly is configured to be mounted on the vehicle via the holes.
5. The assembly of claim 1, wherein the first, second, and 10 third lamps are connected to a common power source.
6. A combination LED lamp assembly comprising:  
 a first lamp in an inner portion of the assembly, having one or more first LEDs and a first power interface; and  
 a flange at least partially surrounding the first lamp, the 15 flange including a second lamp having one or more second LEDs and a second power interface coupled to a switch,  
 wherein the first lamp is a stop/turn/tail lamp and the second lamp is a back-up lamp and a work lamp,

**14**

- wherein the one or more second LEDs are high output LEDs configured to provide the back-up lamp function at a first luminosity when the switch coupled to the second power interface is turned off, and to provide the work lamp function at a second, higher luminosity when the switch coupled to the second power interface is turned on.
7. The assembly of claim 6, wherein the one or more second LEDs are configured to provide a light output of about 310 lm when operated as a back-up lamp and about 1,000 lm when operated as a work lamp.
8. The assembly of claim 6, wherein the assembly is configured to be mounted on a vehicle.
9. The assembly of claim 8, wherein the flange includes a plurality of holes and the assembly is configured to be mounted on the vehicle via the holes.
10. The assembly of claim 6, wherein the first and second lamps are connected to a common power source.

\* \* \* \* \*