



US011374442B2

(12) **United States Patent**  
**Hunstable**

(10) **Patent No.:** **US 11,374,442 B2**  
(45) **Date of Patent:** **\*Jun. 28, 2022**

(54) **MULTI-TUNNEL ELECTRIC MOTOR/GENERATOR**

(71) Applicant: **Linear Labs, LLC**, Granbury, TX (US)  
(72) Inventor: **Fred E. Hunstable**, Granbury, TX (US)  
(73) Assignee: **Linear Labs, LLC**, Granbury, TX (US)

(\* ) Notice: Subject to any disclaimer, the term of this patent is extended or adjusted under 35 U.S.C. 154(b) by 35 days.

This patent is subject to a terminal disclaimer.

(21) Appl. No.: **16/566,132**

(22) Filed: **Sep. 10, 2019**

(65) **Prior Publication Data**

US 2020/0083759 A1 Mar. 12, 2020

**Related U.S. Application Data**

(63) Continuation of application No. 16/374,132, filed on Apr. 3, 2019, now Pat. No. 10,439,452, which is a (Continued)

(51) **Int. Cl.**

**H02K 1/02** (2006.01)  
**H02K 1/17** (2006.01)

(Continued)

(52) **U.S. Cl.**

CPC ..... **H02K 1/02** (2013.01); **H02K 1/27** (2013.01); **H02K 3/12** (2013.01); **H02K 3/18** (2013.01);

(Continued)

(58) **Field of Classification Search**

CPC ..... H02K 16/00; H02K 47/04; H02K 16/02; H02K 47/20; H02K 16/025; H02K 47/14

(Continued)

(56) **References Cited**

U.S. PATENT DOCUMENTS

2,703,370 A 3/1955 Steensen  
3,300,663 A 1/1967 Rosaen  
(Continued)

FOREIGN PATENT DOCUMENTS

AU 2013235132 B2 7/2017  
CN 2226352 Y 5/1996  
(Continued)

OTHER PUBLICATIONS

Aydin, Metin, et al., "Design and 3D Electromagnetic Field Analysis of Non-slotted and Slotted TORUS Type Axial Flux Surface Mounted Permanent Magnet Disc Machines," IEEE International Electric Machines and Drives Conference, Jun. 17-20, 2001, pp. 645-651.

(Continued)

*Primary Examiner* — Burton S Mullins

(57) **ABSTRACT**

Disclosed are various embodiments for a new and improved electrical motor/generator, specifically a motor/generator comprising: a plurality of coils radially positioned about a coil assembly, a plurality of magnetic tunnels forming a relative rotational path for the coil assembly, wherein the all of plurality of magnets forming each magnetic tunnel have like poles facing inward toward the interior of the magnetic tunnel or facing outward away from the interior of the magnetic tunnel such that each magnetic field of any magnetic tunnel is of an opposite polarity to the magnetic field of an adjacent magnetic tunnel.

**18 Claims, 24 Drawing Sheets**

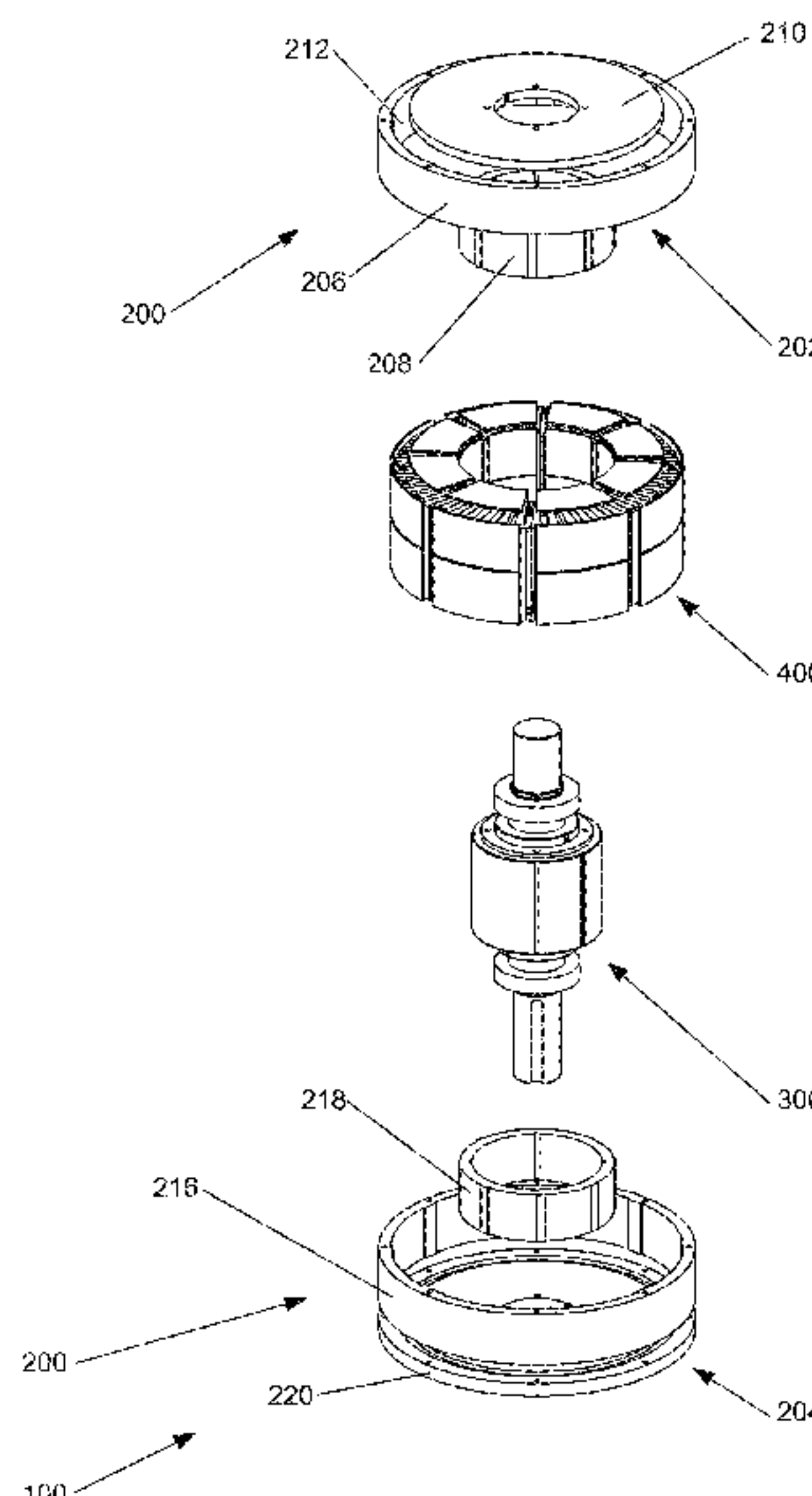

**Related U.S. Application Data**

continuation of application No. 15/657,173, filed on Jul. 23, 2017, now Pat. No. 10,256,680, which is a continuation of application No. 15/492,529, filed on Apr. 20, 2017, now Pat. No. 97,299,016, which is a continuation-in-part of application No. PCT/US2016/026776, filed on Apr. 8, 2016, and a continuation-in-part of application No. 14/866,788, filed on Sep. 25, 2015, now Pat. No. 10,263,480, said application No. 14/866,788 is a continuation-in-part of application No. 13/848,048, filed on Mar. 20, 2013, now Pat. No. 9,419,483.

- (60) Provisional application No. 62/173,349, filed on Jun. 9, 2015, provisional application No. 62/167,412, filed on May 28, 2015, provisional application No. 62/144,654, filed on Apr. 8, 2015, provisional application No. 62/056,389, filed on Sep. 26, 2014, provisional application No. 62/055,615, filed on Sep. 25, 2014, provisional application No. 62/055,612, filed on Sep. 25, 2014, provisional application No. 61/613,022, filed on Mar. 20, 2012.

(51) **Int. Cl.**

- H02K 1/27* (2022.01)
- H02K 1/278* (2022.01)
- H02K 1/06* (2006.01)
- H02K 21/12* (2006.01)
- H02K 21/14* (2006.01)
- H02K 21/26* (2006.01)
- H02K 3/12* (2006.01)
- H02K 21/24* (2006.01)
- H02K 3/18* (2006.01)
- H02K 21/22* (2006.01)
- H02K 1/2786* (2022.01)
- H02K 1/2793* (2022.01)

(52) **U.S. Cl.**

- CPC ..... *H02K 21/12* (2013.01); *H02K 21/24* (2013.01); *H02K 1/278* (2013.01); *H02K 1/2786* (2013.01); *H02K 1/2793* (2013.01); *H02K 21/14* (2013.01); *H02K 21/22* (2013.01)

(58) **Field of Classification Search**

- USPC ..... 310/112–114, 179, 180, 266, 310/156.01–156.83

See application file for complete search history.

(56) **References Cited**

U.S. PATENT DOCUMENTS

- 3,469,133 A 9/1969 Stcherbatcheff
- 3,895,245 A 7/1975 Bode
- 3,979,619 A 9/1976 Whiteley
- 4,237,396 A 12/1980 Blenkinsop
- 4,371,801 A 2/1983 Richter
- 4,388,547 A 6/1983 Gruber
- 4,441,043 A 4/1984 DeCesare
- 4,488,075 A 12/1984 DeCesare
- 4,538,086 A 8/1985 Marsh
- 4,547,713 A 10/1985 Langley et al.
- 4,629,921 A 12/1986 Gavaletz
- 4,814,651 A 3/1989 Elris
- 5,004,944 A 4/1991 Fisher
- 5,099,158 A 3/1992 Stuart et al.
- 5,245,238 A 9/1993 Lynch et al.
- 5,594,289 A 1/1997 Minato
- 5,691,589 A 11/1997 Keim et al.
- 5,821,710 A 10/1998 Masuzawa
- 5,825,113 A 10/1998 Lipo

- 5,886,450 A 2/1999 Kuehnle
- 5,962,947 A 10/1999 Suzuki et al.
- 5,977,684 A 11/1999 Lin
- 6,054,834 A 4/2000 Ha
- 6,093,986 A 7/2000 Windhorn
- 6,104,108 A 8/2000 Hazelton
- 6,211,597 B1 4/2001 Nakano
- 6,388,352 B1 5/2002 Huang
- 6,462,430 B1 10/2002 Houng et al.
- 6,531,799 B1 3/2003 Miller
- 6,664,689 B2 12/2003 Rose
- 6,664,704 B2 12/2003 Calley
- 6,774,591 B2 8/2004 Arimitsu et al.
- 6,803,691 B2 10/2004 Rose
- 6,806,607 B2 10/2004 Lau
- 6,891,299 B2 5/2005 Coupart
- 6,924,574 B2 8/2005 Qu et al.
- 6,924,579 B2 8/2005 Calley
- 6,930,421 B2 8/2005 Rose
- 6,930,422 B2 8/2005 Rose
- 6,967,424 B2 11/2005 Popov
- 6,979,925 B2 12/2005 Schwamm
- 7,049,722 B2 5/2006 Rose
- 7,233,088 B2 6/2007 Wise
- 7,279,818 B1 10/2007 Wise
- 7,315,103 B2 1/2008 Qu
- 7,348,703 B2 3/2008 Bojiuc
- 7,378,749 B2 5/2008 Moore
- 7,554,241 B2 6/2009 Rao
- 7,732,973 B2 6/2010 Bojiuc
- 7,755,244 B2 7/2010 Ley et al.
- 7,765,905 B2 8/2010 Frumper
- 7,791,242 B2 9/2010 Bojiuc
- 7,834,503 B2 11/2010 Bojiue
- 7,898,134 B1 3/2011 Shaw
- 8,008,821 B2 8/2011 Calley
- 8,063,528 B2 11/2011 Toot
- 8,074,922 B2 12/2011 Bojiuc
- 8,159,104 B1 4/2012 Bojiuc
- 8,232,695 B2 7/2012 Bojiuc
- 8,288,916 B2 10/2012 Quere
- 8,362,731 B2 1/2013 Smith
- 8,400,037 B2 3/2013 Wojtowicz
- 8,415,848 B2 4/2013 Calley
- 8,598,754 B2 12/2013 Lacour
- 8,816,554 B2 8/2014 Li et al.
- 8,847,464 B2 9/2014 Qu et al.
- 8,912,699 B2 12/2014 Kuntz
- 9,219,962 B2 12/2015 Hunstable
- 9,287,745 B2 3/2016 Akatsu et al.
- 9,419,483 B2 8/2016 Hunstable
- RE46,449 E 6/2017 Bojiuc
- 9,729,016 B1 8/2017 Hunstable
- 9,825,496 B2 11/2017 Hunstable
- 9,876,407 B2 1/2018 Walsh
- 10,125,814 B2 11/2018 Walsh
- 10,256,680 B2 4/2019 Hunstable
- 10,263,480 B2 4/2019 Hunstable
- 10,284,029 B2 5/2019 Hunstable
- 10,326,343 B2 6/2019 Walsh
- 10,340,768 B2 7/2019 Walsh
- 10,439,452 B2\* 10/2019 Hunstable ..... H02K 21/24
- 10,447,103 B2 10/2019 Hunstable
- 10,476,362 B2 11/2019 Hunstable
- 2003/0025417 A1 2/2003 Rose
- 2004/0027022 A1 2/2004 Weir
- 2004/0061397 A1 4/2004 Rose
- 2004/0194286 A1 10/2004 Rose
- 2004/0195932 A1 10/2004 Rose
- 2004/0195933 A1 10/2004 Rose
- 2004/0232800 A1 11/2004 Seguchi et al.
- 2005/0194855 A1 9/2005 Hasebe
- 2006/0038454 A1 2/2006 Bojiuc
- 2006/0055272 A1 3/2006 Lee et al.
- 2006/0273686 A1 12/2006 Edelson et al.
- 2007/0228860 A1 10/2007 Rao
- 2008/0278019 A1 11/2008 Lu et al.
- 2009/0102305 A1 4/2009 Lu
- 2009/0224627 A1 9/2009 Hino et al.



(56)

References Cited

U.S. PATENT DOCUMENTS

2009/0224628 A1 9/2009 Hiwaki et al.  
 2009/0261675 A1 10/2009 Hsiao et al.  
 2010/0164422 A1 7/2010 Shu et al.  
 2010/0289365 A1 11/2010 Bando et al.  
 2011/0187222 A1 8/2011 Li et al.  
 2011/0309708 A1 12/2011 Van Neste  
 2012/0153763 A1 6/2012 Kenji  
 2012/0286616 A1 11/2012 Li  
 2013/0249343 A1 9/2013 Hunstable  
 2013/0334902 A1 12/2013 Oiwa et al.  
 2013/0334937 A1 12/2013 Yamada et al.  
 2014/0062236 A1 3/2014 Taniguchi et al.  
 2014/0070651 A1 3/2014 Gerfast  
 2014/0191612 A1 7/2014 Mariotto  
 2015/0137647 A1 5/2015 Hunstable  
 2015/0171694 A1 6/2015 Walsh  
 2016/0020652 A1 1/2016 Hunstable  
 2016/0094096 A1 3/2016 Hunstable  
 2017/0163115 A1 6/2017 Gotz  
 2017/0222494 A1 8/2017 Hunstable  
 2018/0219464 A1 8/2018 Newmark et al.  
 2018/0278134 A1 9/2018 Hunstable  
 2018/0331593 A1 11/2018 Hunstable  
 2019/0103793 A1 4/2019 Walsh  
 2019/0199185 A1 6/2019 Hunstable  
 2019/0260243 A1 8/2019 Hunstable  
 2019/0312497 A1 10/2019 Walsh  
 2019/0356251 A1 11/2019 Hunstable  
 2020/0007016 A1 1/2020 Hunstable  
 2020/0083759 A1 3/2020 Hunstable  
 2020/0112212 A1 4/2020 Hunstable  
 2021/0066984 A1 3/2021 Hunstable  
 2021/0067016 A1 3/2021 Hunstable

FOREIGN PATENT DOCUMENTS

CN 2452204 Y 10/2001  
 CN 101005229 A 7/2007  
 CN 101212150 B 5/2011  
 CN 102687378 A 9/2012  
 CN 102761179 A 10/2012  
 CN 102761211 A 10/2012  
 CN 102792569 A 11/2012  
 CN 103683768 A 3/2014  
 CN 104272559 A 1/2015  
 CN 104285366 B 10/2017  
 CN 107710569 A 2/2018  
 CN 109891726 A 6/2019  
 CN 107925328 B 6/2020  
 EP 1191673 A2 3/2002  
 EP 1990894 A2 11/2008  
 JP S51133709 11/1976  
 JP S5492305 12/1977  
 JP S58116050 A 7/1983  
 JP S61173658 A 8/1986  
 JP S61144782 9/1986  
 JP 2002-254268 A 9/2002  
 JP 2002369473 A 12/2002  
 JP 2006217771 A 8/2006  
 JP 2008-043127 A 2/2008  
 JP 2008141853 A 6/2008  
 JP 2010166741 A 7/2010  
 JP 2015-177646 A 10/2015  
 JP 6223418 B2 10/2017  
 JP 2019-527022 A 9/2019  
 KR 1020070092089 A 7/2008  
 KR 1020090033866 A 2/2010  
 KR 101276633 B1 6/2013  
 KR 10-2048601 B1 11/2019  
 KR 10-2150817 8/2020  
 WO 2008006906 A1 1/2008  
 WO 2008096913 A1 8/2008  
 WO 2011032675 A2 3/2011  
 WO 2014188737 A1 11/2014  
 WO 2016014717 A1 1/2016

WO 2016164818 A1 10/2016  
 WO 2017003955 A1 1/2017  
 WO 2017070403 A1 4/2017  
 WO 2018045360 A1 3/2018  
 WO 2020150536 A1 7/2020

OTHER PUBLICATIONS

Aydin, Metin, et al., "Performance Evaluation of an Axial Flux Consequent Pole PM Motor using Finite Element Analysis," IEEE International Electric Machines and Drives Conference, vol. 3, Jun. 1-4, 2003, pp. 1682-1687.  
 Huang, Surong, et al., "TORUS Concept Machines: Pre-Prototyping Design Assessment for Two Major Topologies," IEEE Industry Applications Conference, vol. 3, Sep. 30-Oct. 4, 2001, pp. 1619-1625.  
 International Search Report and Written Opinion of the ISA, dated Aug. 8, 2014, re PCT/US2013/033198.  
 International Search Report and Written Opinion of the ISA, dated Aug. 18, 2016, re PCT/US2016/026776.  
 International Search Report and Written Opinion, dated Nov. 3, 2016, by the ISA/RU, re PCT/US2016/039673.  
 International Search Report and Written Opinion, dated Jan. 9, 2017, by the ISA/US, re PCT/US2016/057999.  
 International Search Report and Written Opinion, dated Mar. 15, 2018, by the ISA/RU, re PCT/US2017/049981.  
 Office Action, dated Jul. 21, 2017, by the USPTO, re U.S. Appl. No. 15/413,228.  
 Final Office Action, dated Mar. 9, 2018, by the USPTO, re U.S. Appl. No. 15/413,228.  
 Office Action, dated Sep. 19, 2018, by the USPTO, re U.S. Appl. No. 15/413,228.  
 Notice of Allowance, dated Apr. 10, 2019, by the USPTO, re U.S. Appl. No. 15/413,228.  
 Office Action, dated Jun. 27, 2019, by the USPTO, re U.S. Appl. No. 15/813,360.  
 EP Exam Report, dated Apr. 18, 2018, by the EPO, re EP App No. 13714168.5.  
 EP Exam Report, dated Oct. 10, 2018, by the EPO, re EP App No. 13714168.5.  
 EP Search Report, dated Oct. 26, 2018, re EP Patent App No. 16777421.5.  
 EP Official Action, dated Nov. 13, 2018, by the EPO, re EP App No. 16777421.5.  
 EP Extended Search Report, dated Feb. 22, 2019, by the EPO, re EP App No. 16818559.3.  
 EP Office Action, dated Mar. 12, 2019, by the EPO, re EP App No. 16818559.3.  
 Extended EP Search Report, dated Apr. 18, 2019, by the EPO, re EP App No. 16858253.4.  
 EP Official Action, dated May 8, 2019, by the EPO, re EP Patent App No. 16858253.4.  
 CA Office Action, dated Jan. 24, 2019, by the CIPO, re CA App No. 2,881,979.  
 Chinese Office Action, dated Apr. 10, 2019, by the CIPO, re CN App No. 201680033171.1.  
 Indian Exam Report, dated Nov. 19, 2018, by IP India, re IN App No. 8335/DELNP/2014.  
 CN Office Action, dated Jun. 5, 2019, by the CIPO, re CN Patent App No. 201680050018.X.  
 CN Office Action, dated Jul. 9, 2019, by the CIPO, re Patent App No. 201680061215.1.  
 KR Office Action, dated Jun. 7, 2019, by KIPO, re KR Patent App No. 10-2014-7029089.  
 EP Exam Report, dated Aug. 9, 2019, by the EPO, re EP Patent App No. 13714168.5.  
 CN Office Action, dated Sep. 12, 2019, by the CIPO, re Patent App No. 201680033171.1.  
 BR Office Action, dated Dec. 3, 2019, by the Brazil Patent Office, re BR Patent App No. BR112014023183-4.  
 EP Official Action, dated Dec. 10, 2019, by the EPO, re EP Patent App No. 16858253.4.

(56)

**References Cited**

## OTHER PUBLICATIONS

Notice of Allowance, dated Jan. 8, 2020, by the USPTO, re U.S. Appl. No. 15/813,360.

CA Office Action, dated Jan. 8, 2020, by the CIPO re CA App No. 2,881,979.

EP Official Action, dated Jan. 29, 2020, by the EPO, re EP Patent App No. 16777421.5.

KR Office Action, dated Feb. 3, 2020, by the KIPO, re KR App No. 10-2019-7033838.

AU Office Action, dated Feb. 26, 2020, by IP Australia, re AU App No. 201634225.

EP Extended Search Report, dated Mar. 17, 2020, by the EPO, re EP App No. 17847669.3.

Office Action, dated Apr. 16, 2020, by the USPTO, re U.S. Appl. No. 16/506,137.

Office Action, dated Apr. 15, 2020, by the USPTO, re U.S. Appl. No. 16/601,529.

International Search Report, dated Apr. 16, 2020, by the ISA/RU, re PCT/US2020/013966.

Written Opinion, dated Apr. 16, 2020, by the ISA/RU, re PCT/US2020/013966.

EP Exam Report, dated Apr. 17, 2020, by the EPO, re EP App No. 16818559.3.

CN 2nd Office Action, dated May 29, 2020, re CN App No. 201680061215.1.

Notice of Allowance, dated May 20, 2020, by the USPTO, re U.S. Appl. No. 15/813,360.

EP Exam Report, dated June 9, 2020, by the EPO, re EP App No. 13714168.5.

In Exam Report, dated Jul. 6, 2020, by the India Patent Office, re IN App No. 201817013288.

Notice of Allowance, dated Jul. 23, 2020, by the USPTO, re U.S. Appl. No. 16/601,529.

Office Action, dated Aug. 4, 2020, by the USPTO, re U.S. Appl. No. 16/404,631.

EP Official Action, dated Apr. 4, 2020, by the EPO, re EP App No. 17847669.3.

CN Office Action, dated Sep. 2, 2020, re CN App No. 201780054222.3.

Office Action-Restriction, dated Sep. 4, 2020, by the USPTO, re U.S. Appl. No. 16/293,515.

BR Exam Report, dated Aug. 25, 2020, by the BPO, re BR App No. BR112018007810-7.

EP Communication pursuant to Article 94(3) EPC, dated Oct. 14, 2020, re EP App No. 16858253.4.

EP Exam Report, dated Oct. 15, 2020, by the EPO, re EP App No. 16818559.3.

Notice of Allowance, dated Oct. 5, 2020, by the USPTO, re U.S. Appl. No. 16/385,344.

Final Office Action, dated Oct. 30, 2020, by the USPTO, re U.S. Appl. No. 16/506,137.

Office Action, dated Oct. 30, 2020, by the USPTO, re U.S. Appl. No. 15/977,120.

Notice of Allowance, dated Nov. 12, 2020, by the USPTO, re U.S. Appl. No. 16/601,529.

JP Office Action, dated Oct. 15, 2020, by JPO, re JP App No. 2018-540691.

Notice of Allowance, dated Nov. 25, 2020, by the USPTO, re U.S. Appl. No. 16/404,631.

Notice of Allowance, dated Dec. 10, 2020, by the USPTO, re U.S. Appl. No. 16/293,515.

Office Action, dated Feb. 22, 2021, by the USPTO, re U.S. Appl. No. 16/506,137.

Notice of Allowance, dated Feb. 2, 2021, by the USPTO, re U.S. Appl. No. 16/385,344.

Notice of Allowance, dated Mar. 3, 2021, by the USPTO, re U.S. Appl. No. 16/601,529.

Notice of Allowance, dated Mar. 24, 2021, by the USPTO, re U.S. Appl. No. 16/404,631.

\* cited by examiner



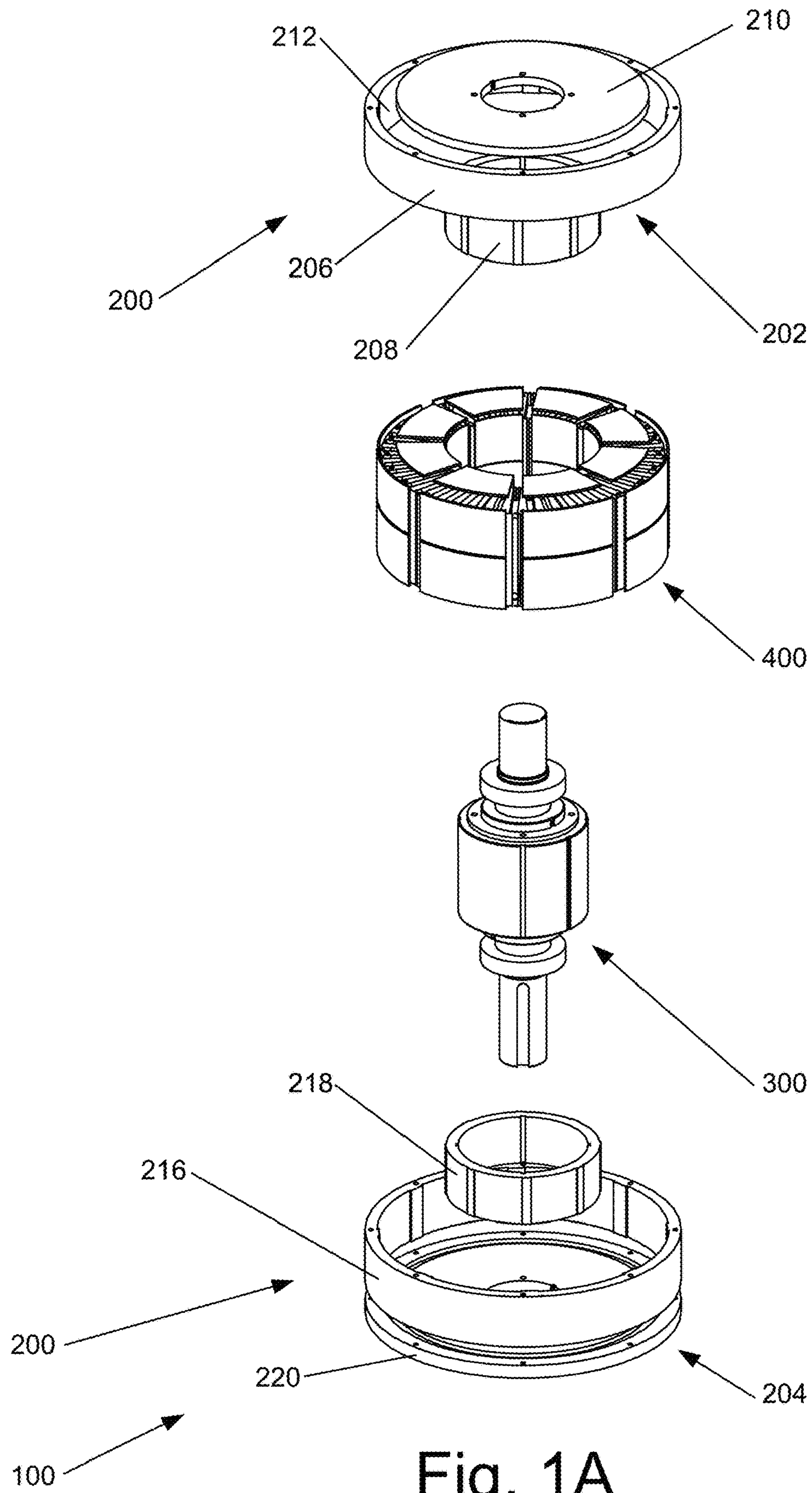

Fig. 1A

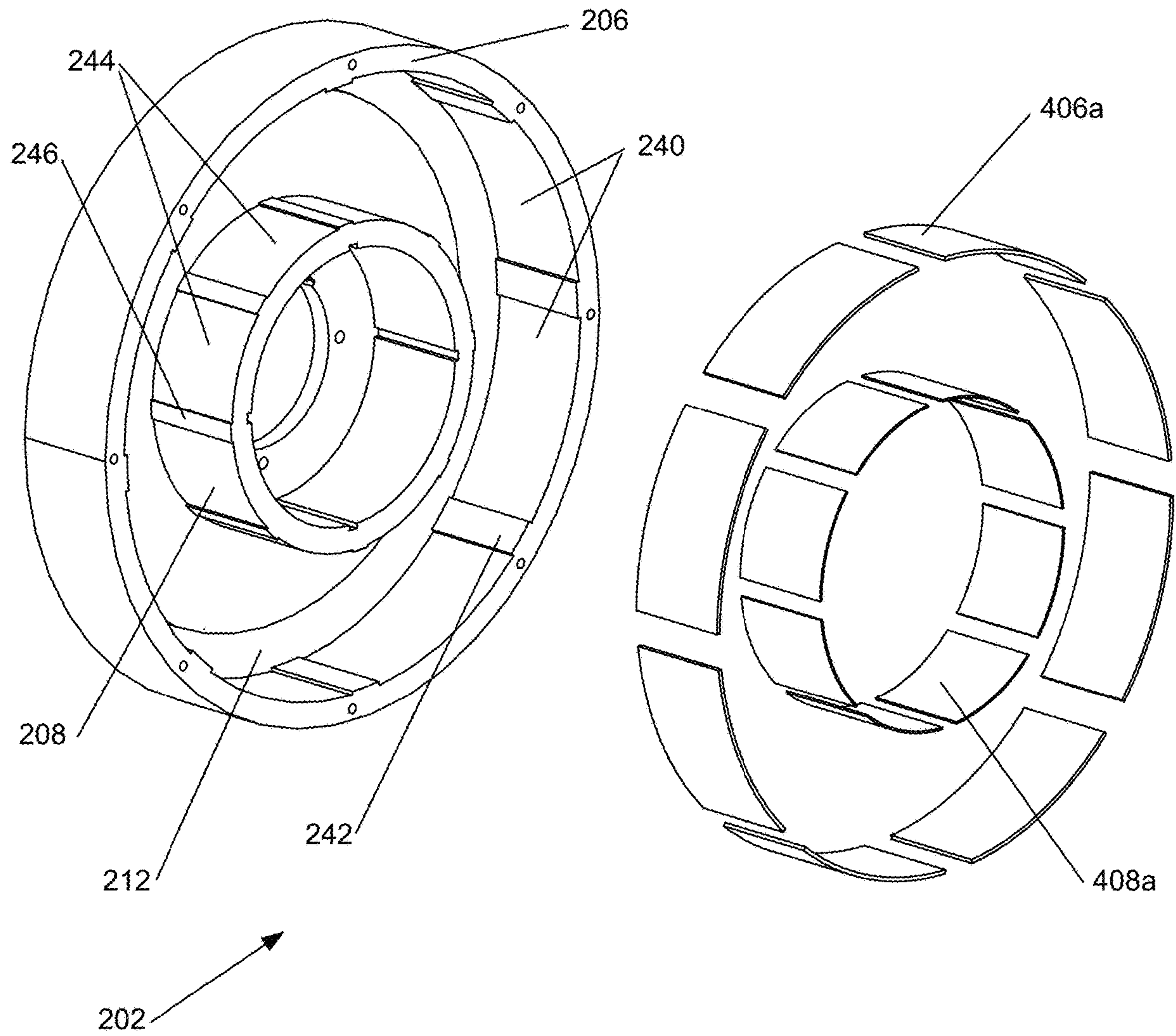

Fig. 1B

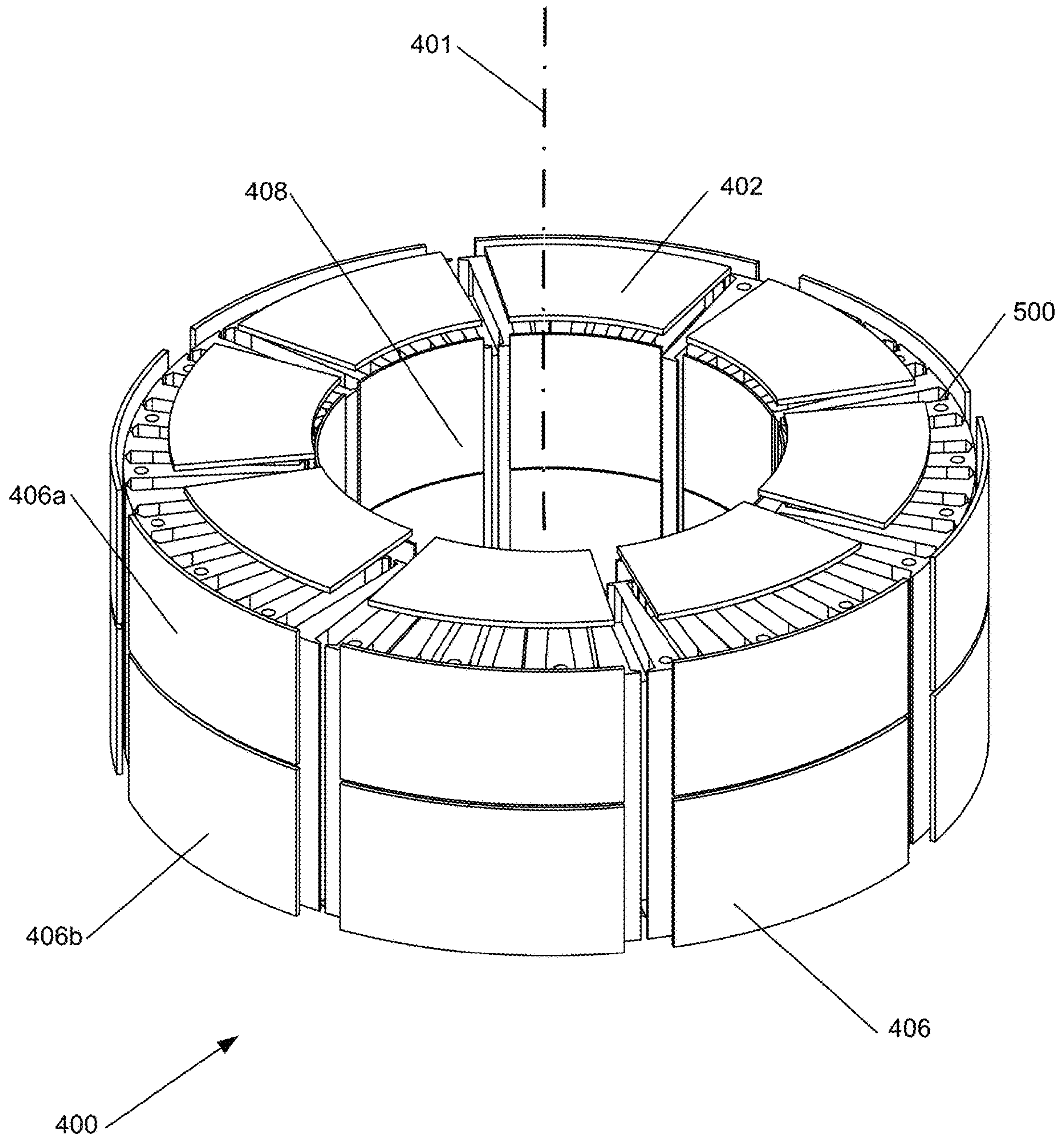

Fig. 2



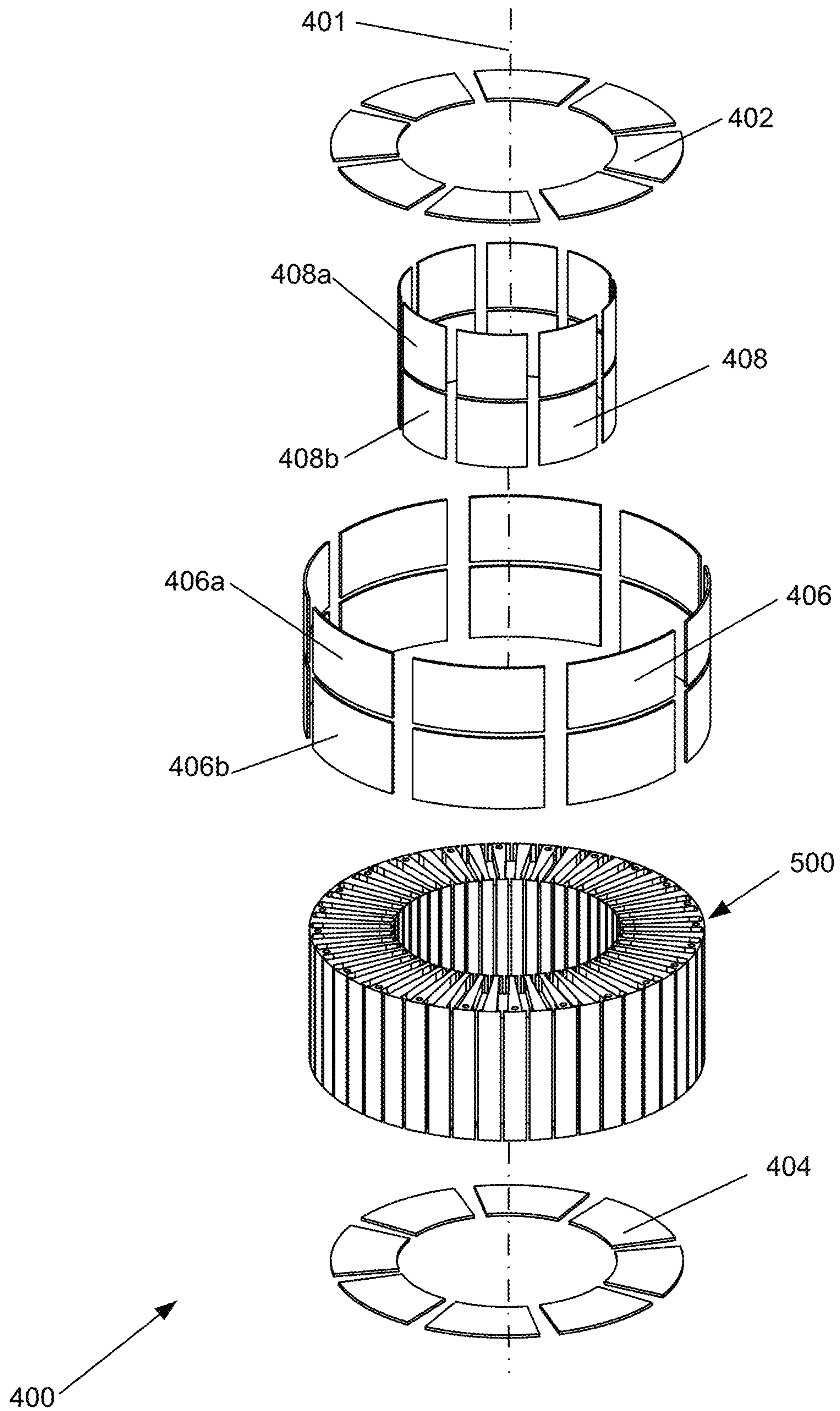

Fig. 3



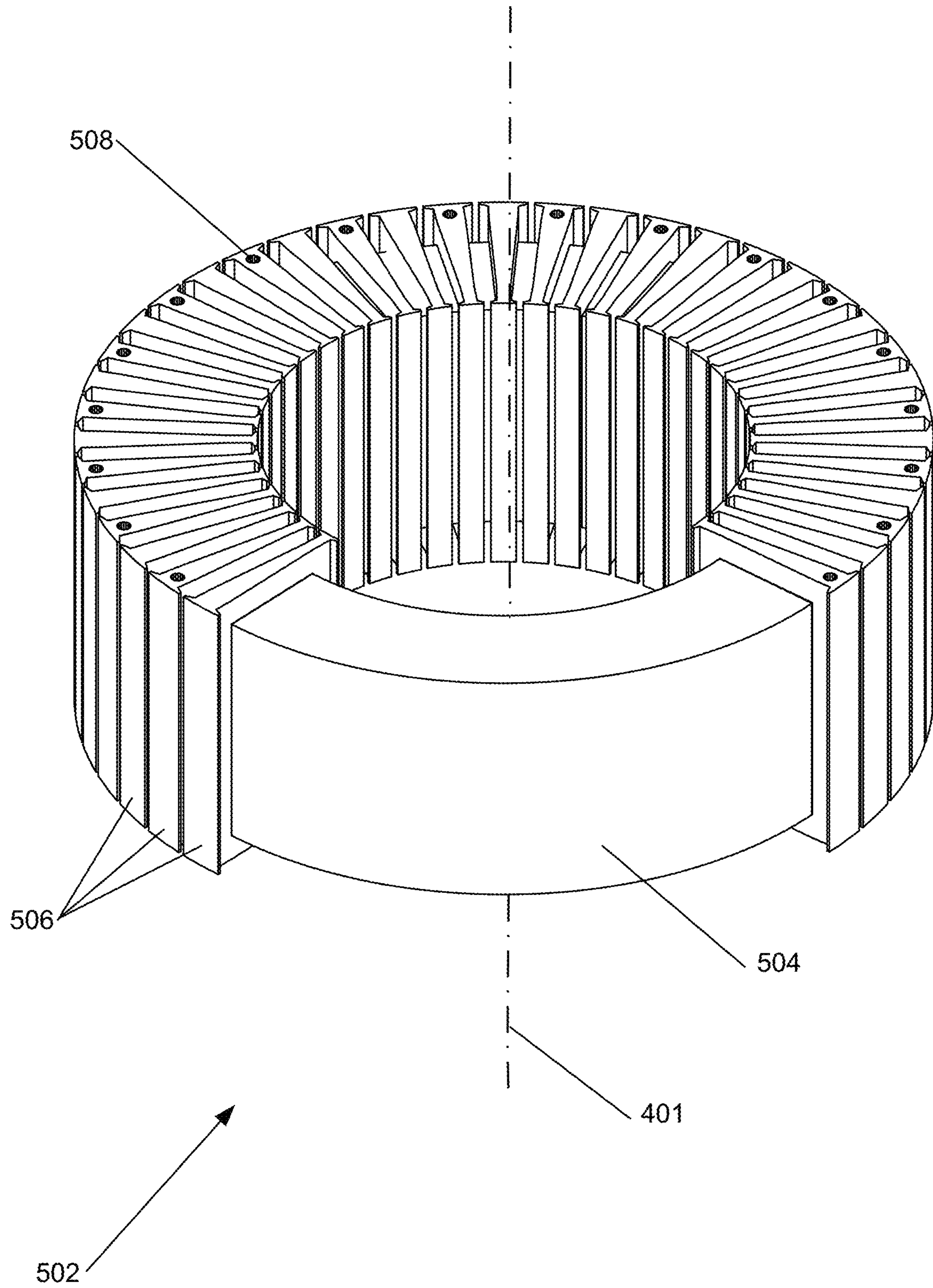

Fig. 4A

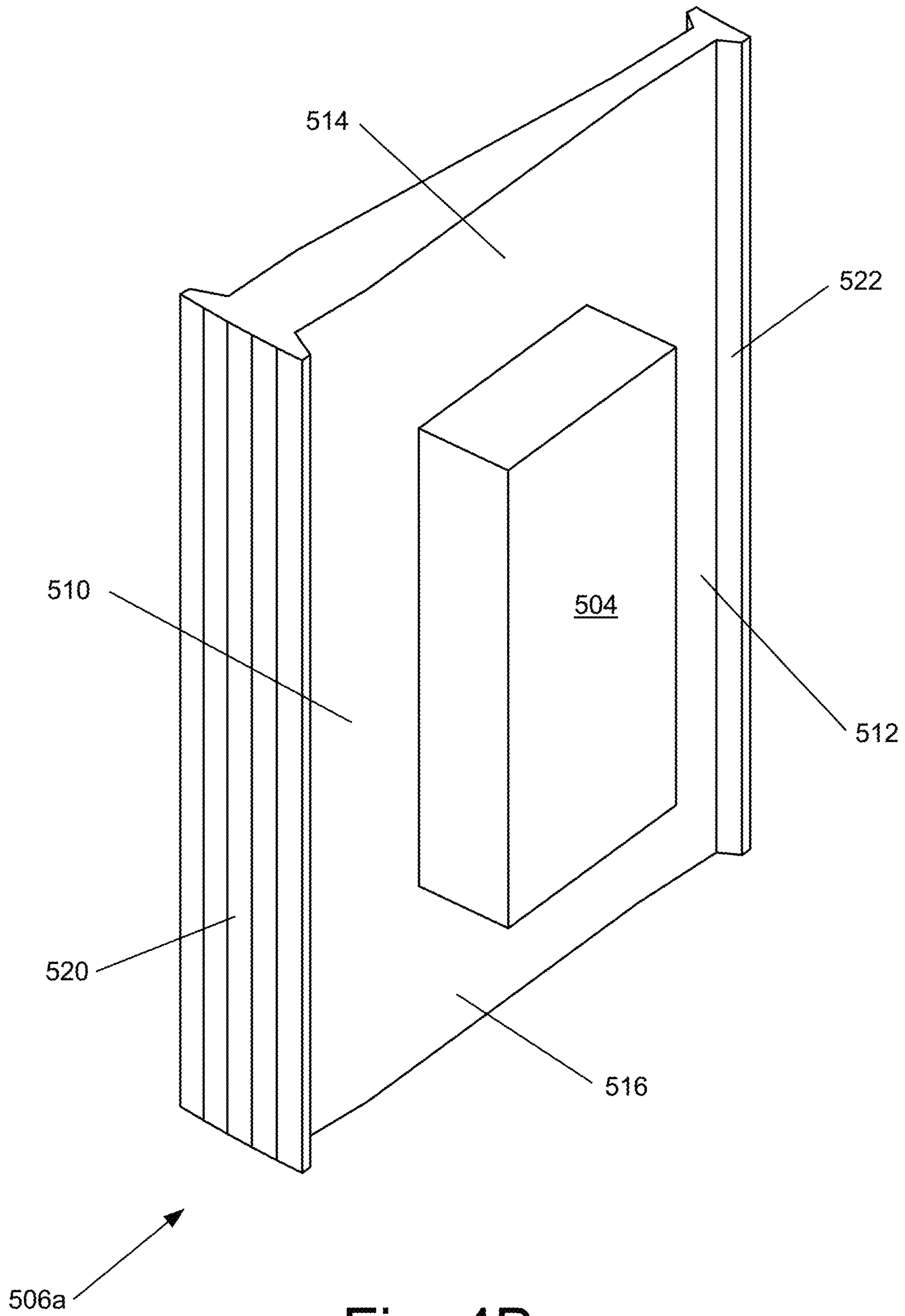

Fig. 4B



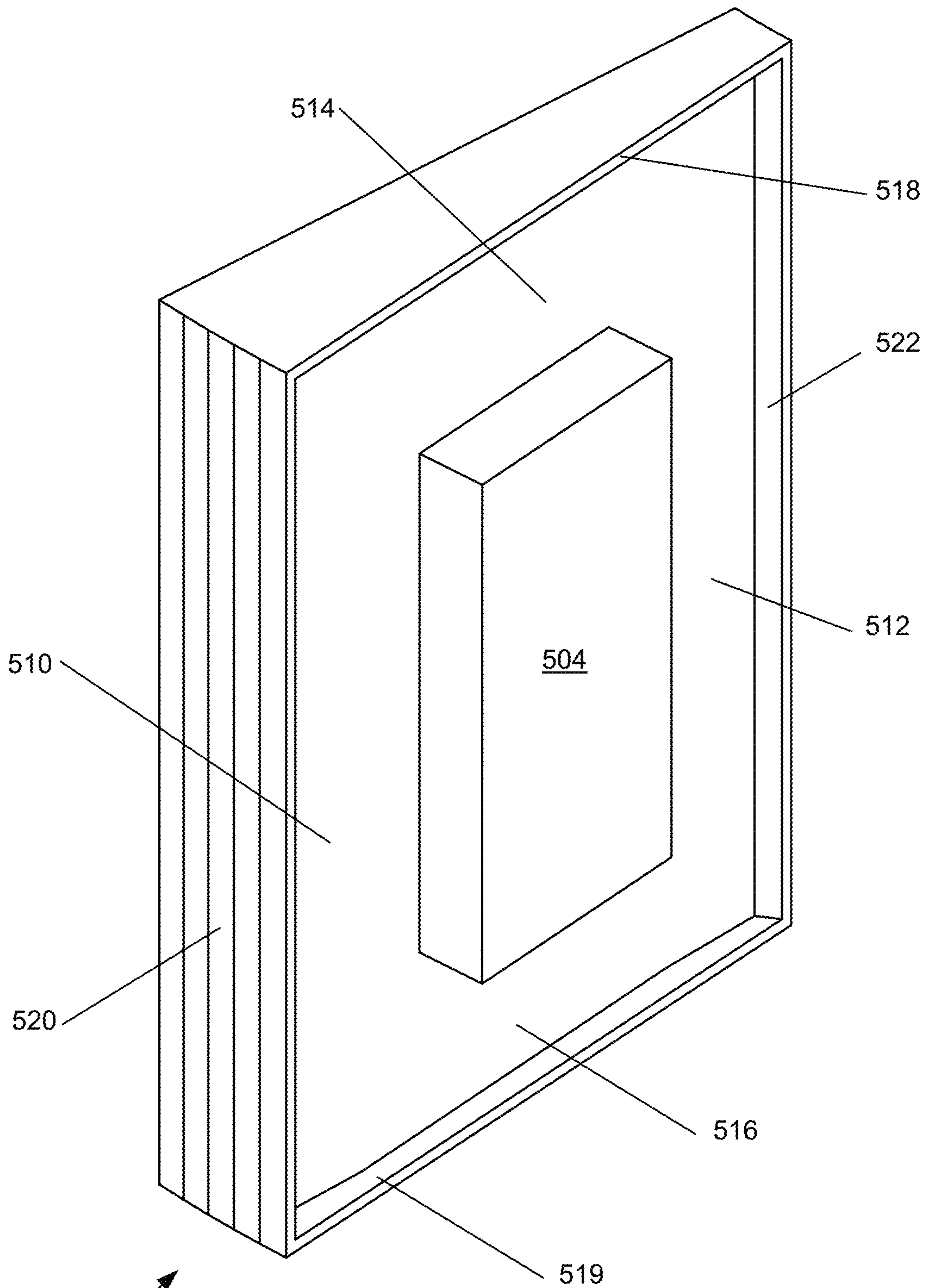

Fig. 4C

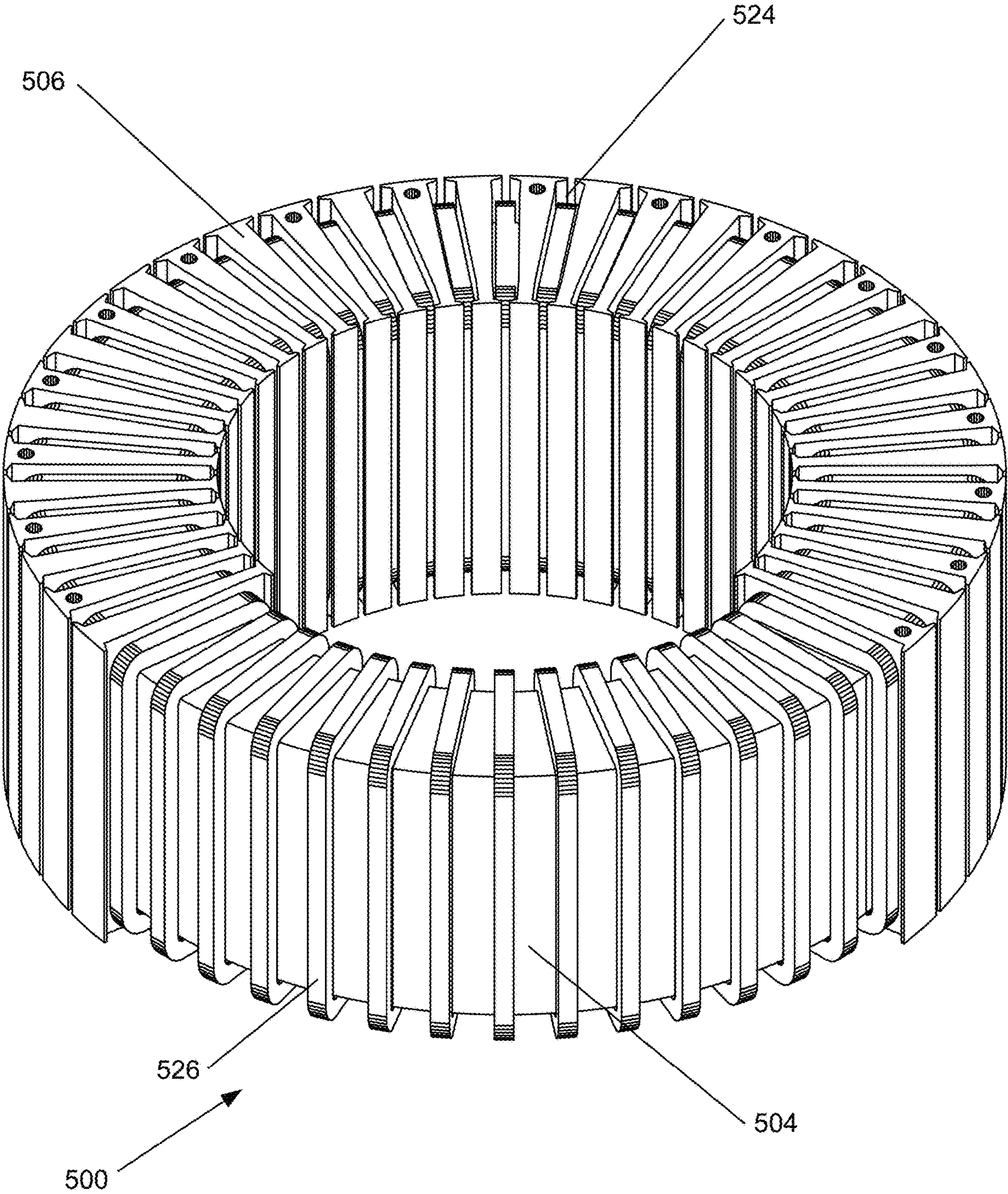

Fig. 4D



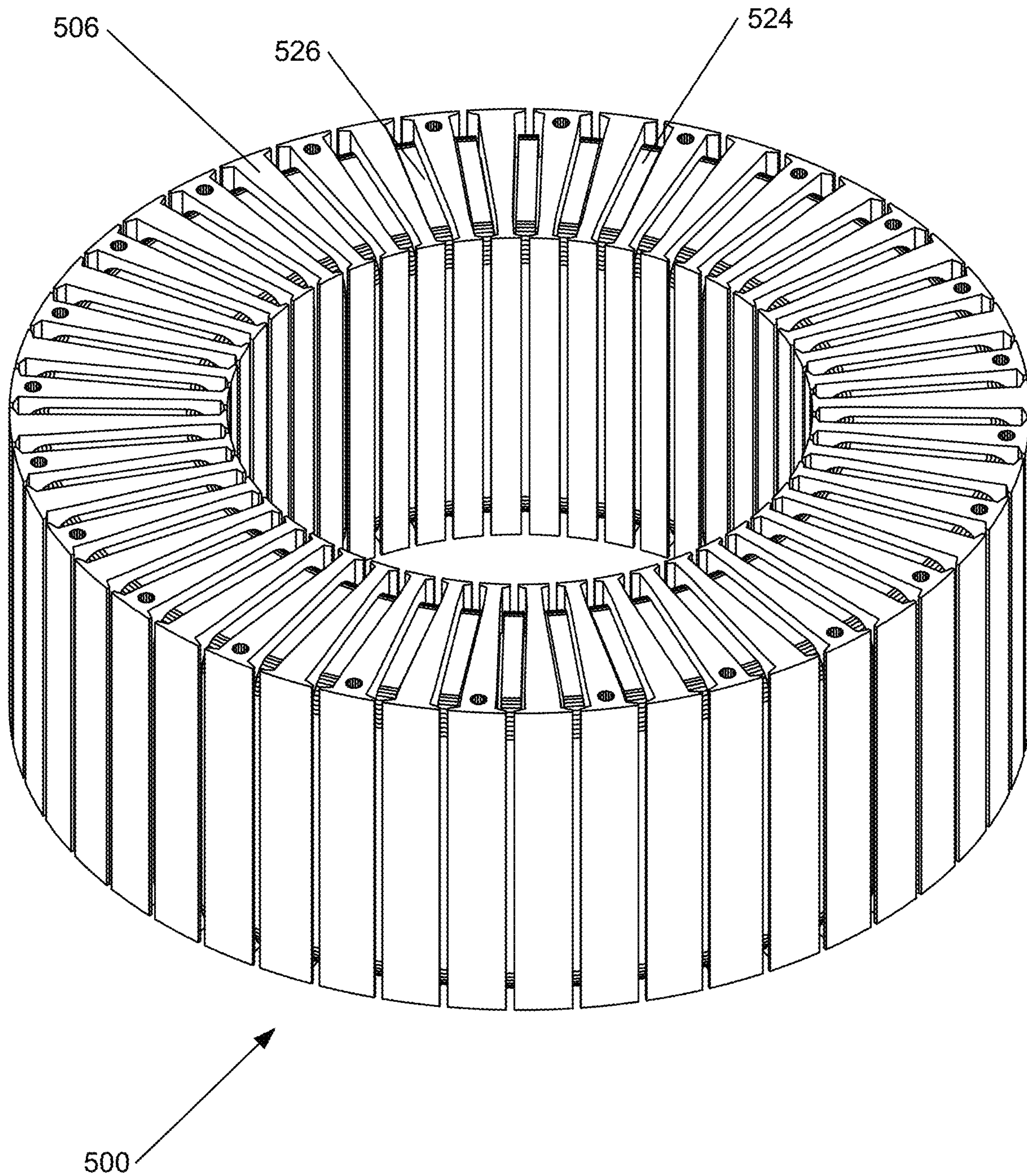

Fig. 4E

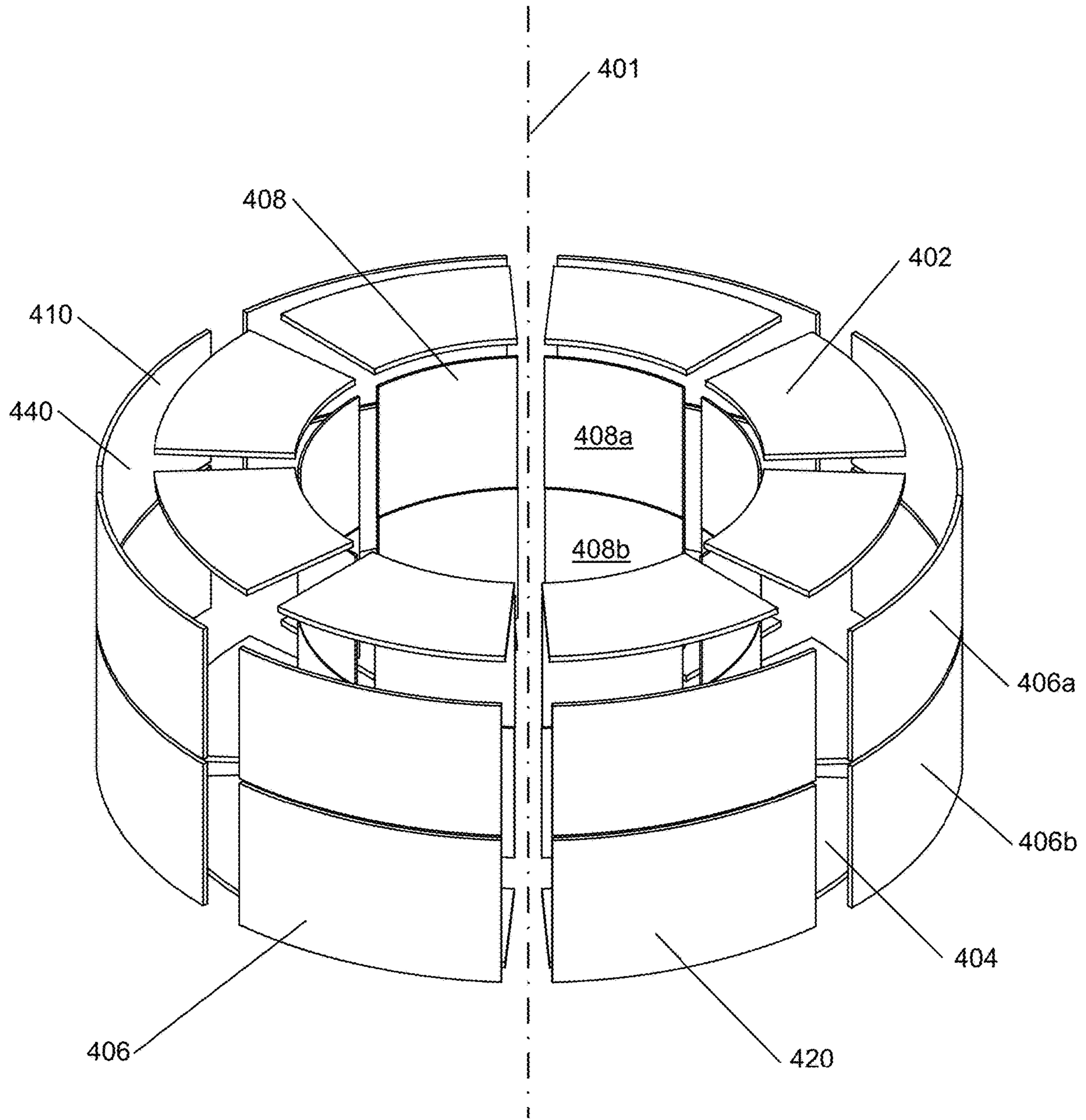

Fig. 5



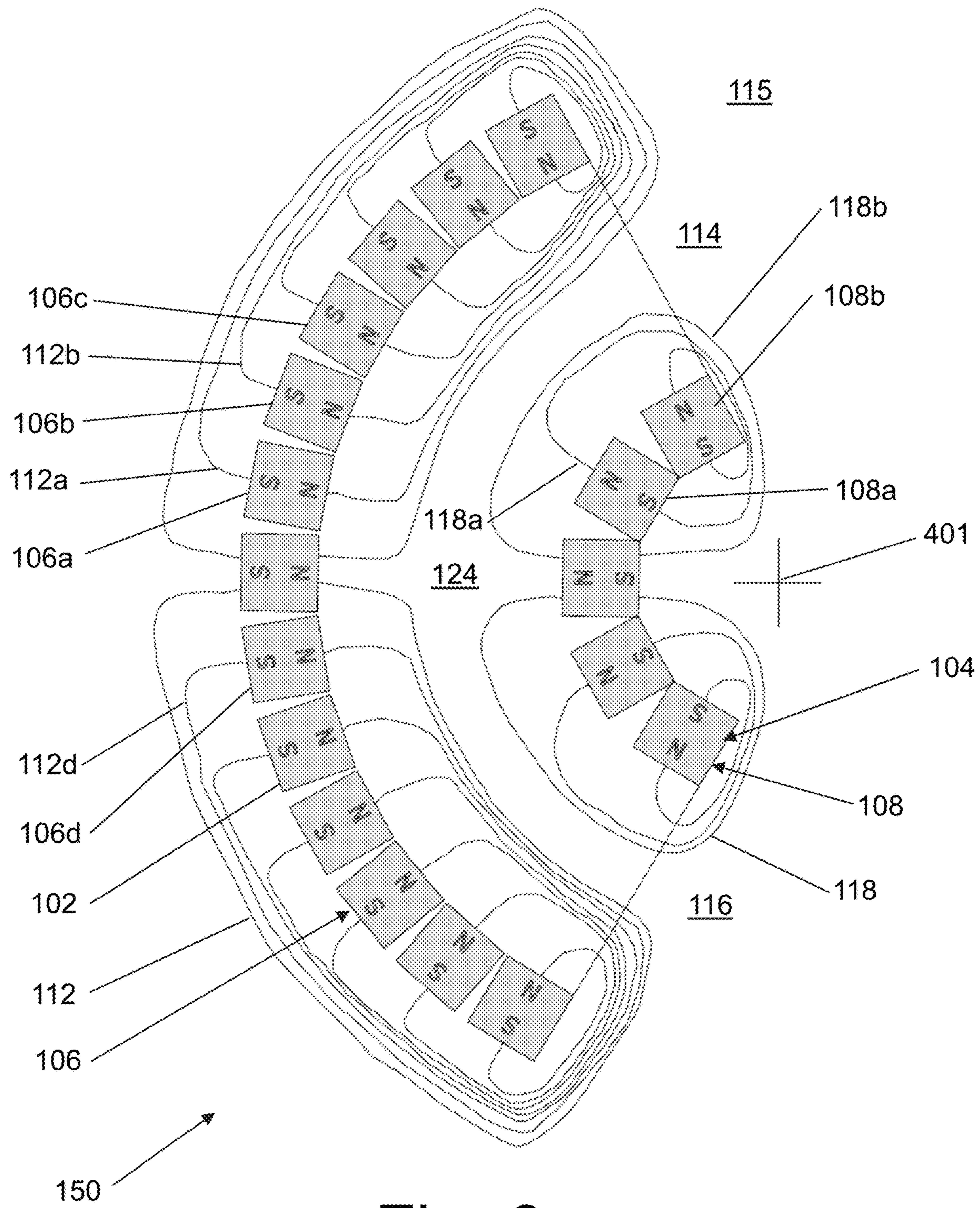

Fig. 6

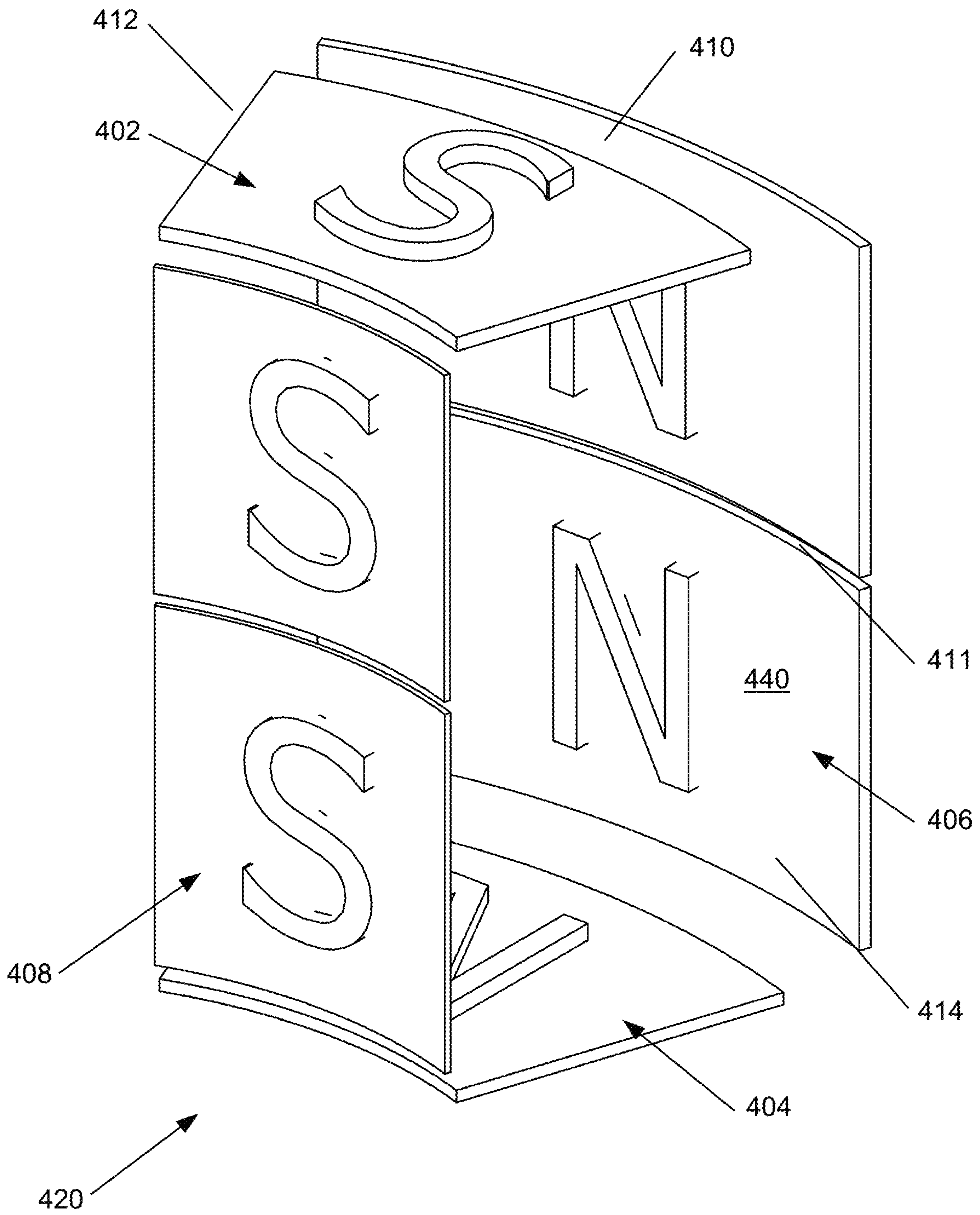

Fig. 7A



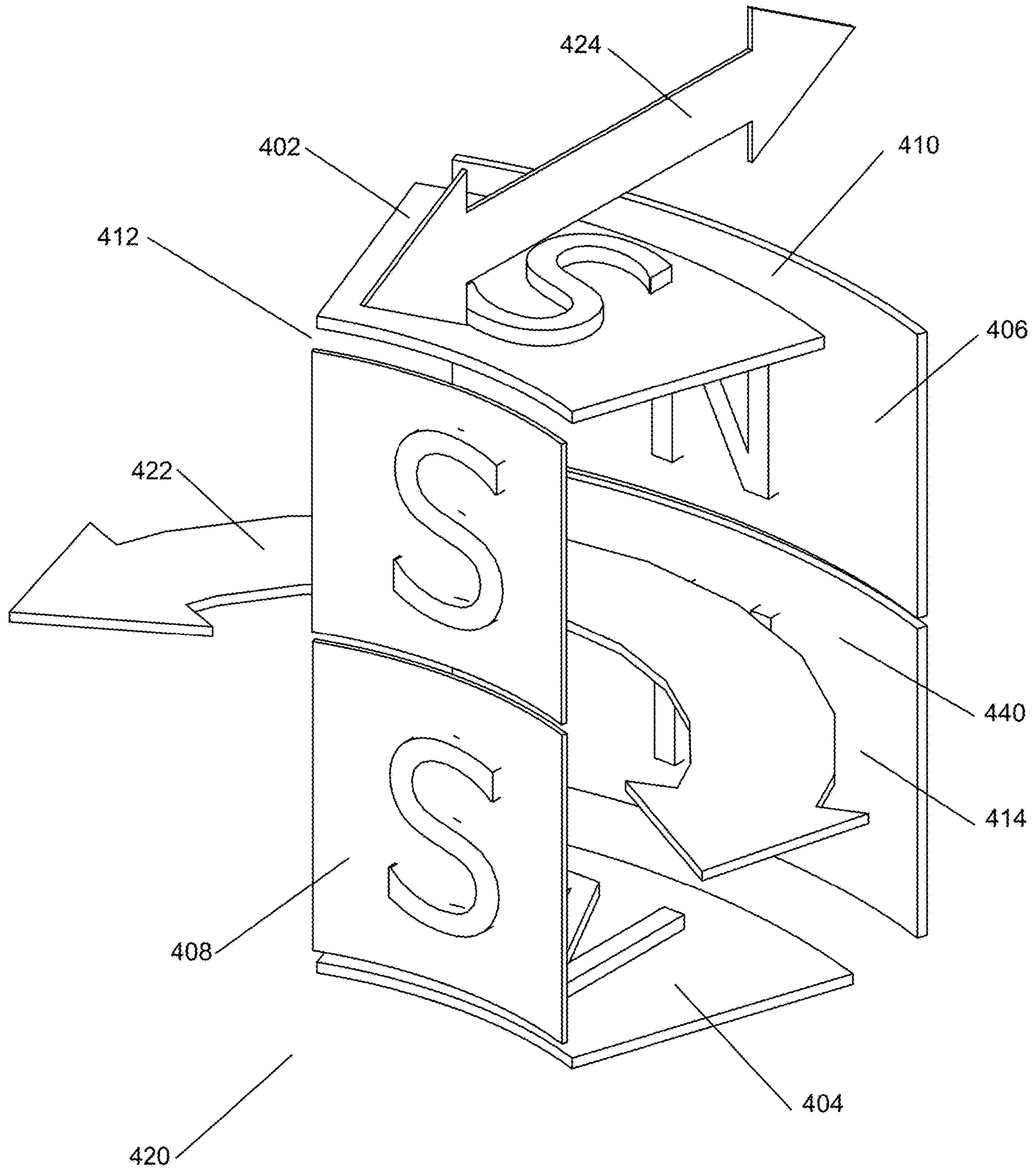

Fig. 7B

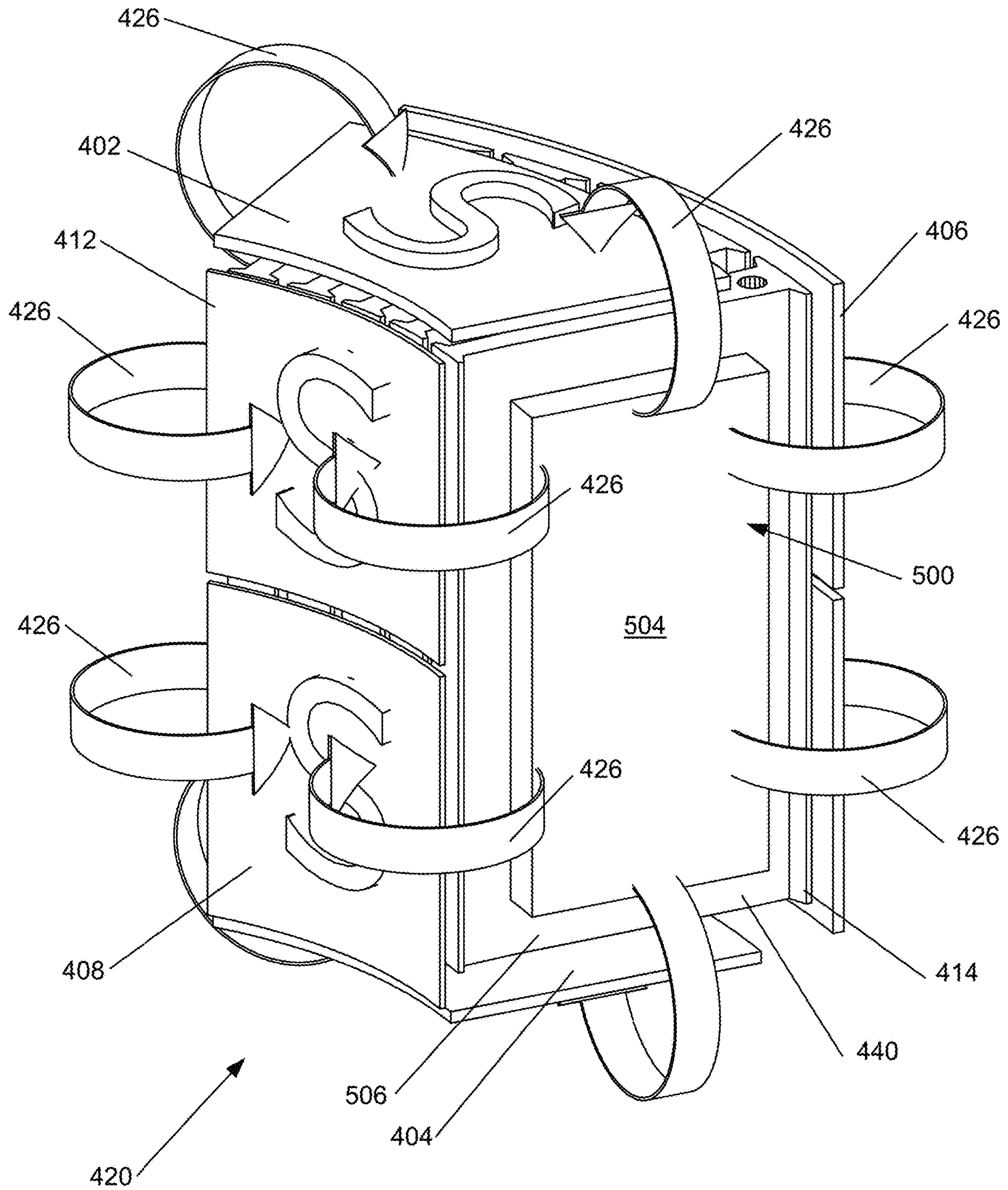

Fig. 7C

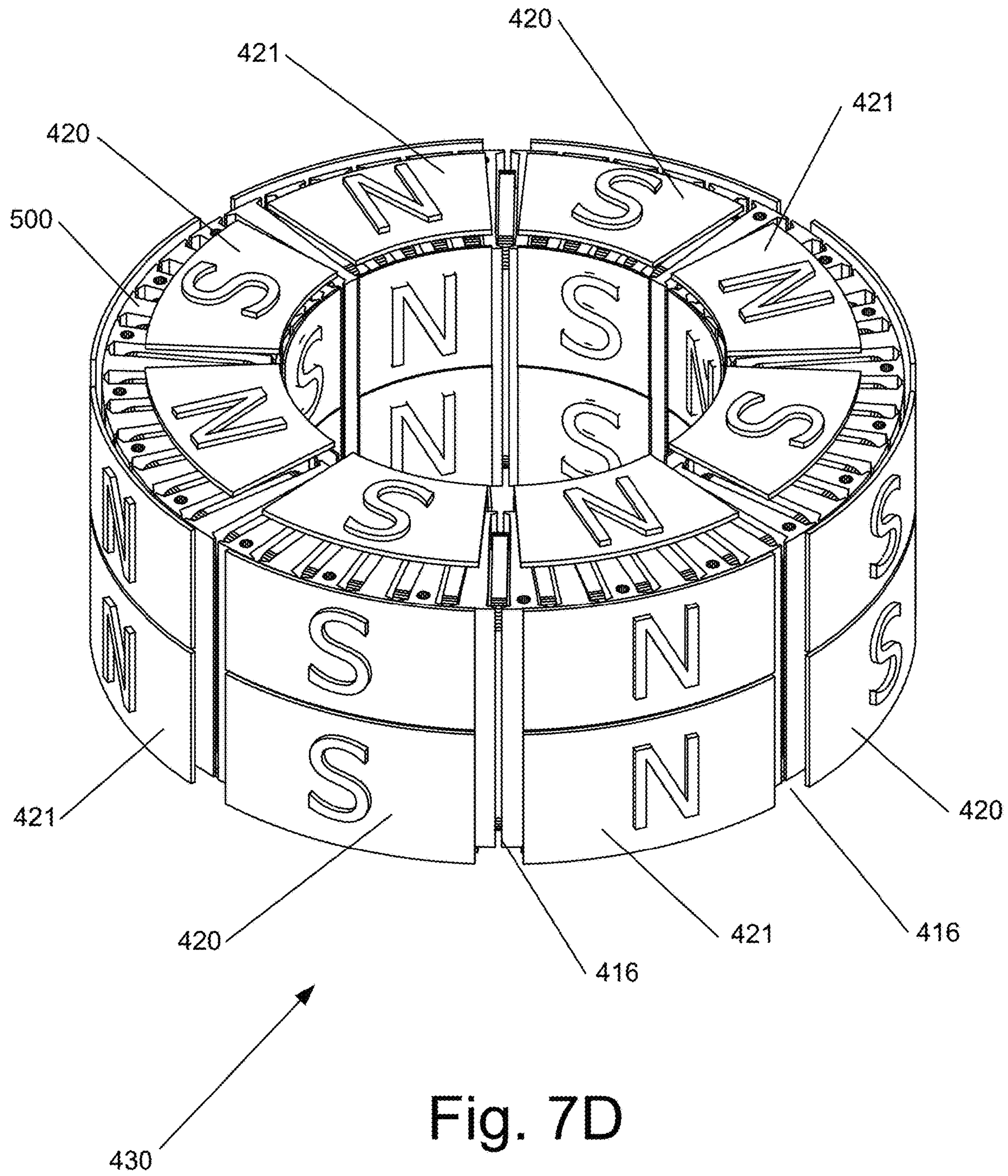

Fig. 7D



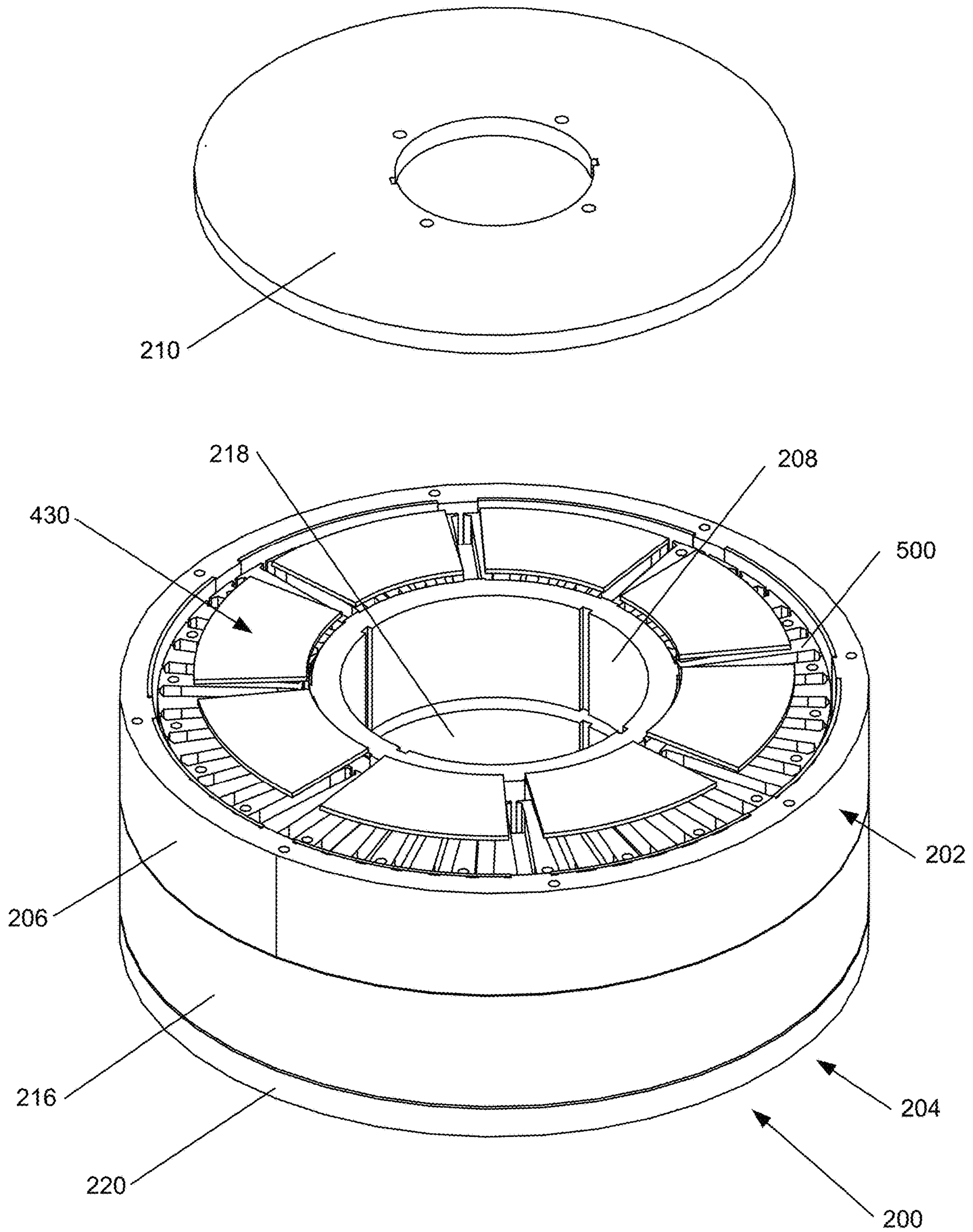

Fig. 8

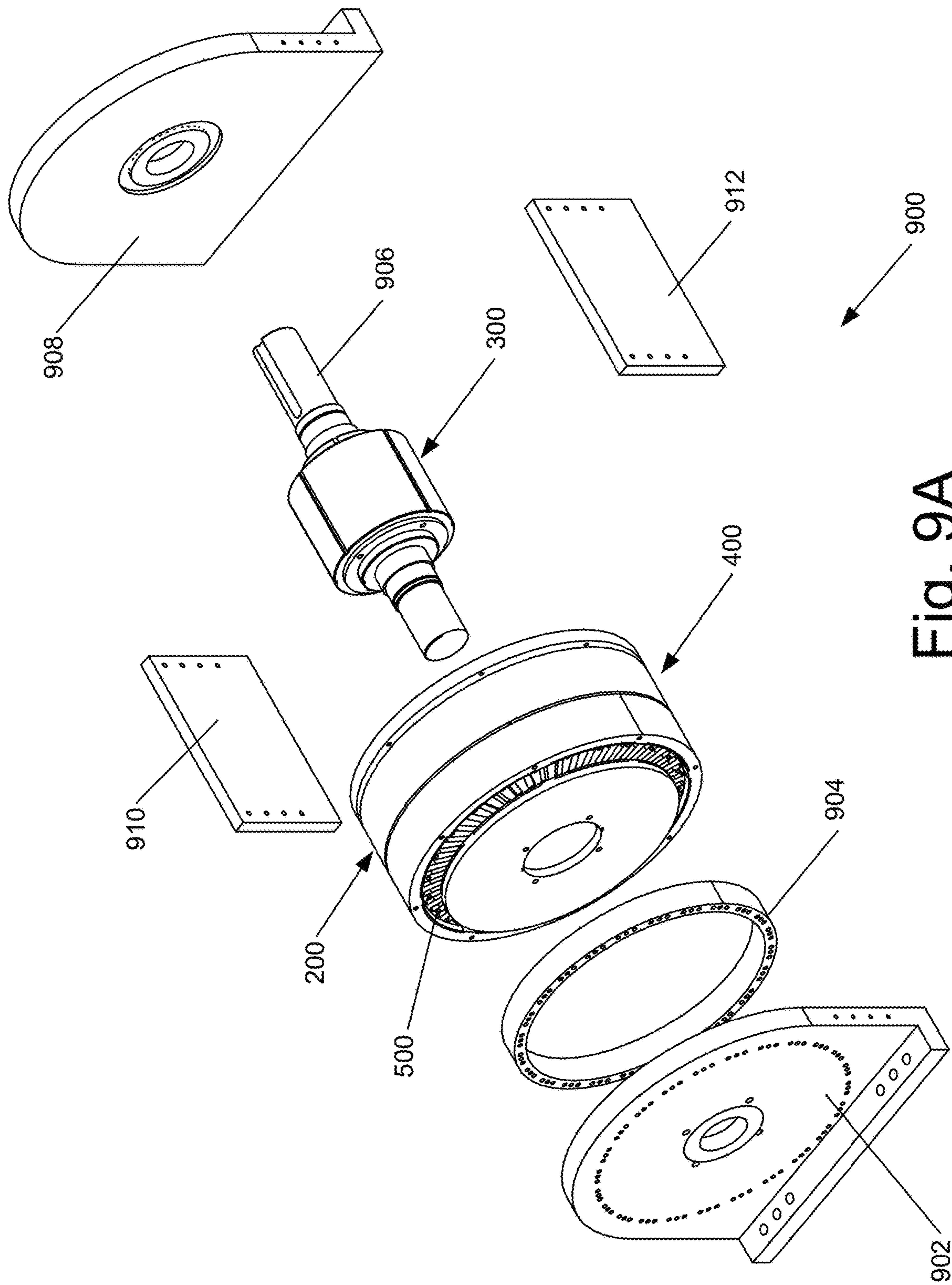

Fig. 9A

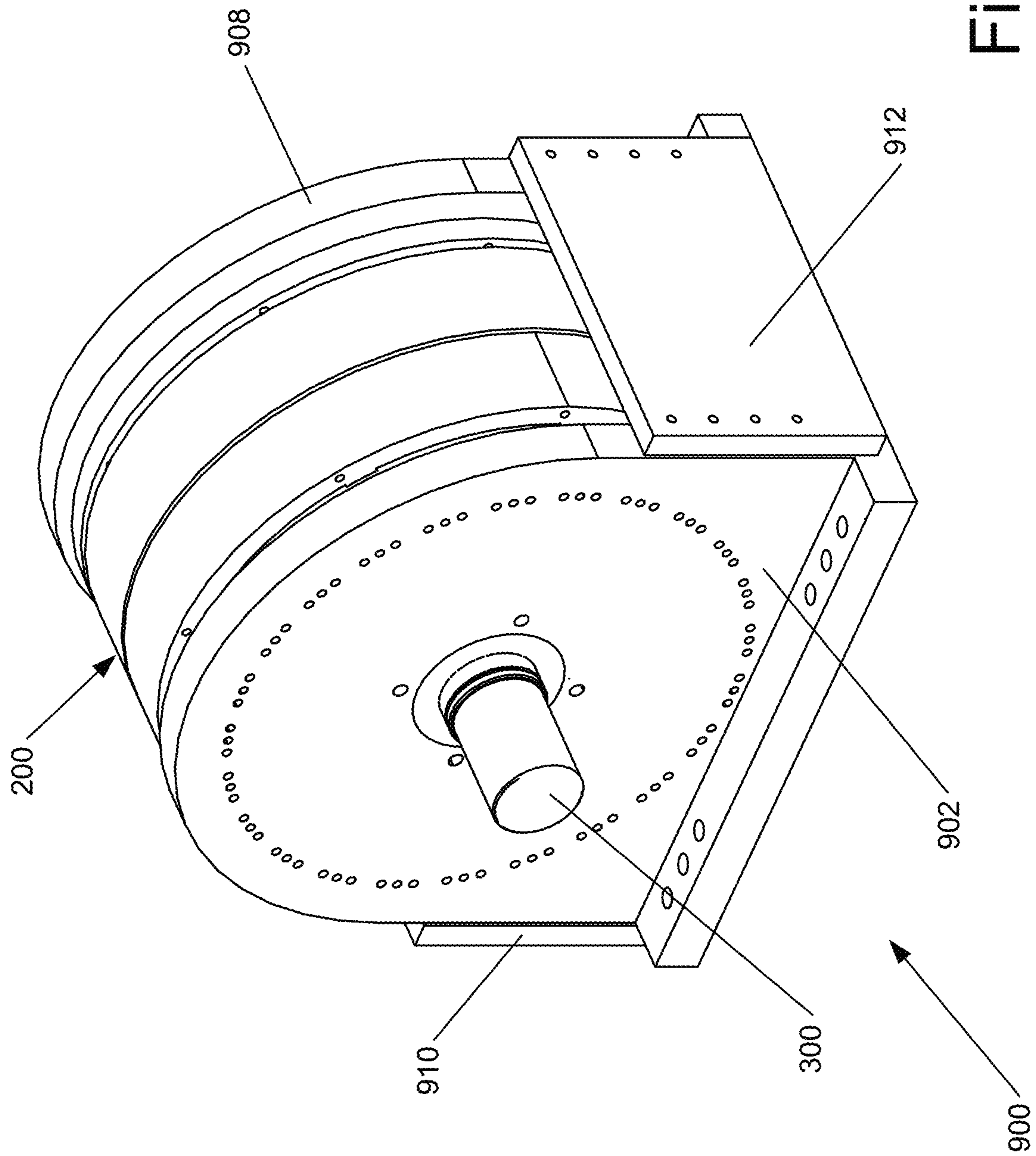

Fig. 9B



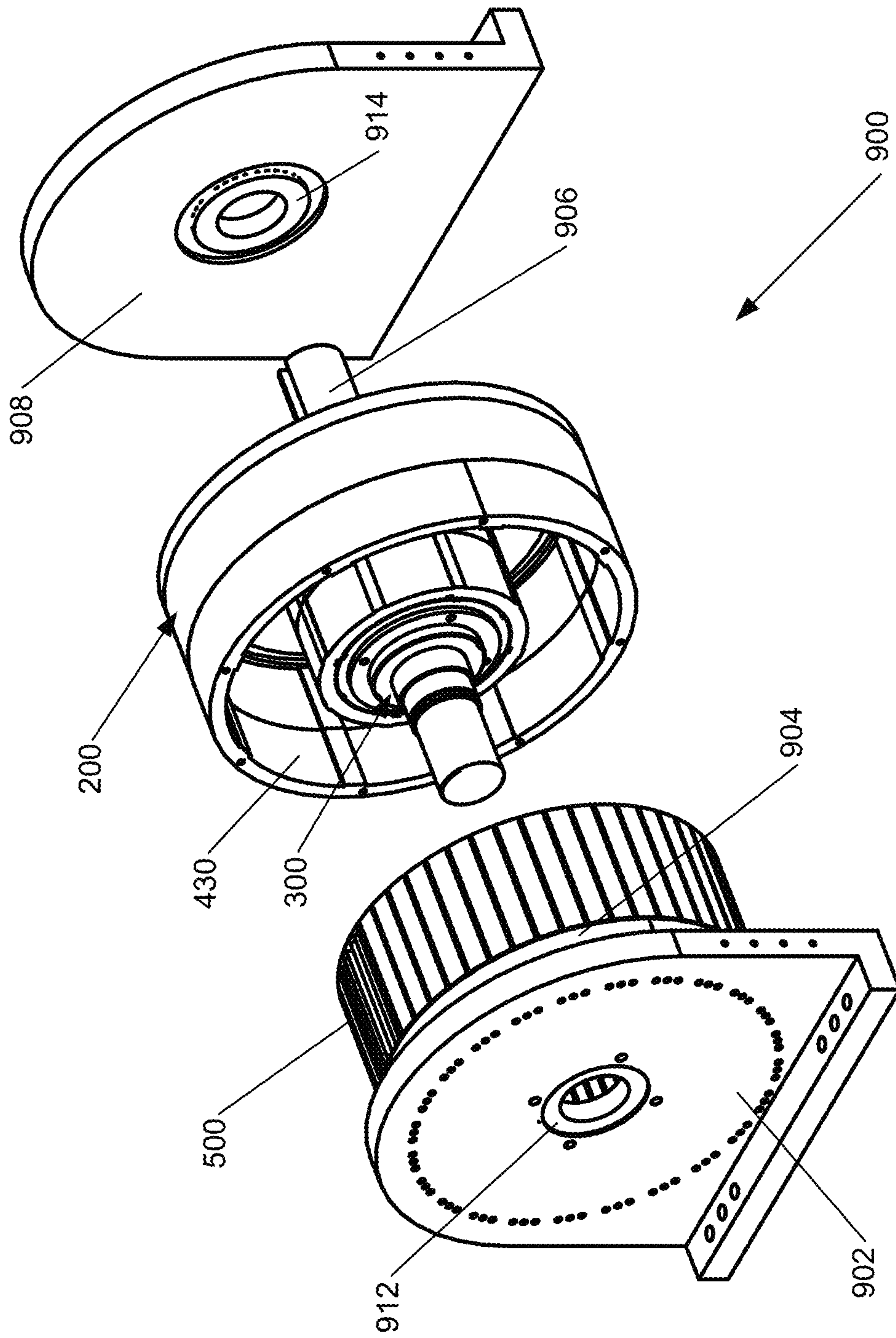

Fig. 10

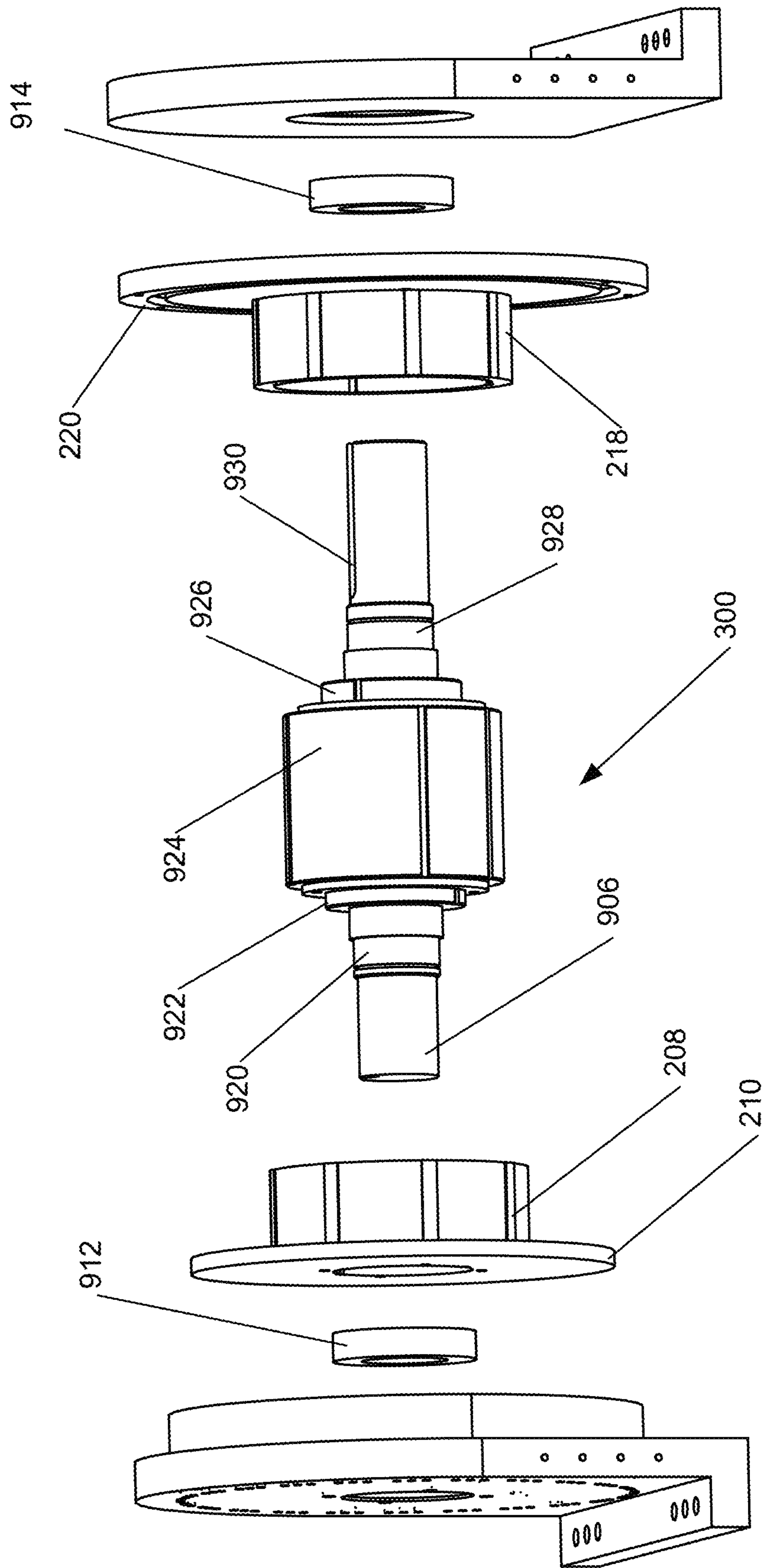

Fig. 11

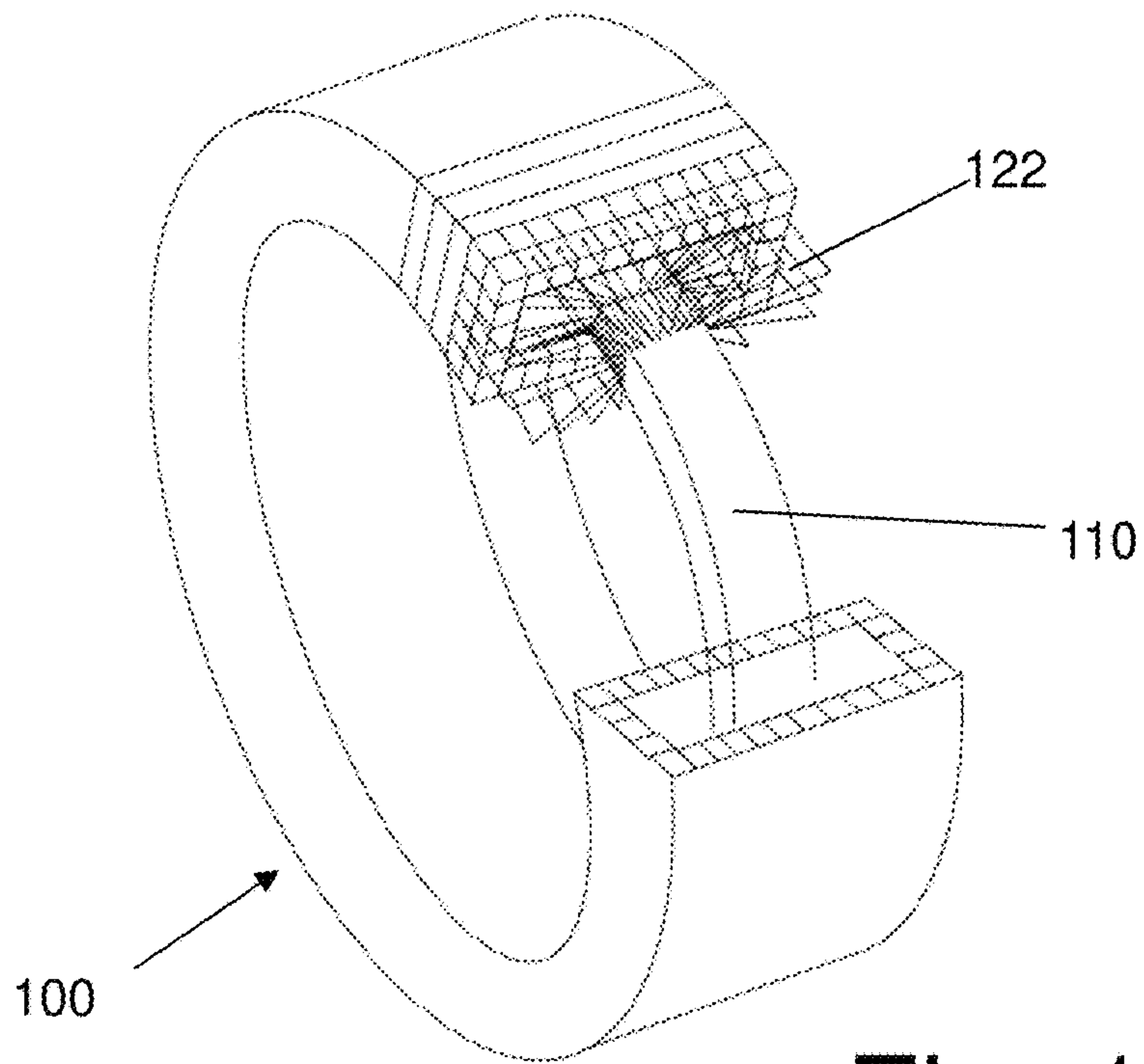

Fig. 12A

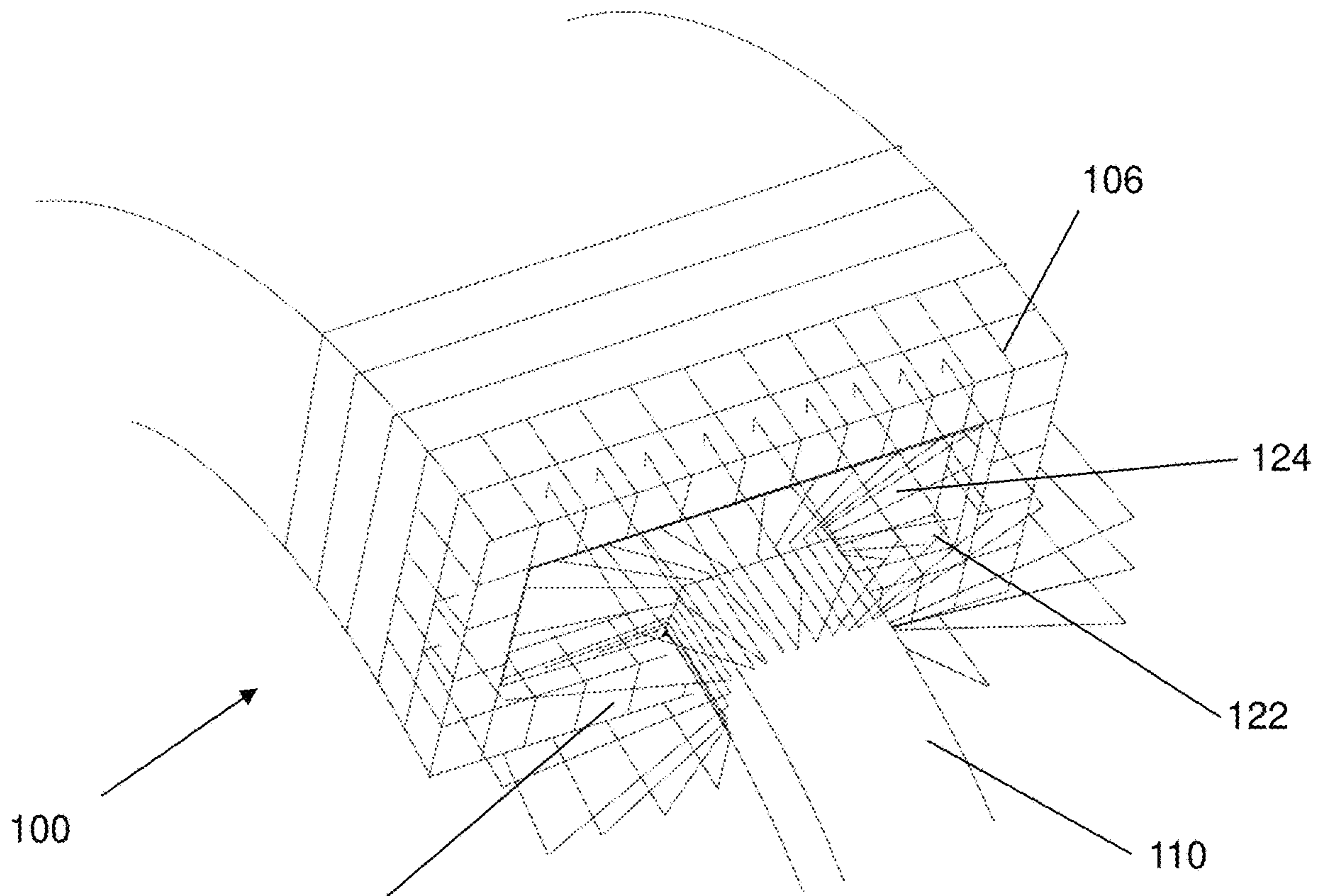

Fig. 12B



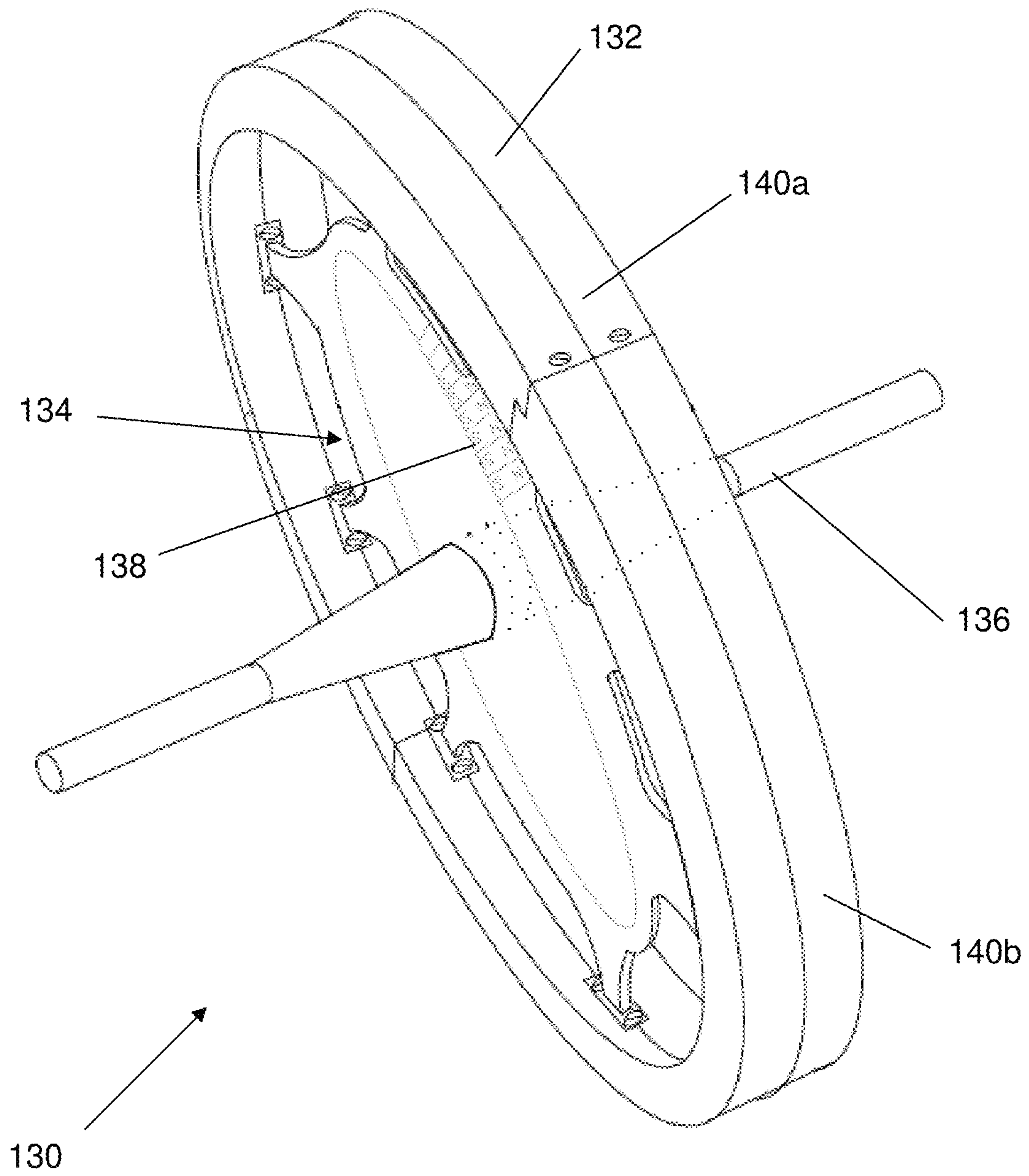

Fig. 13

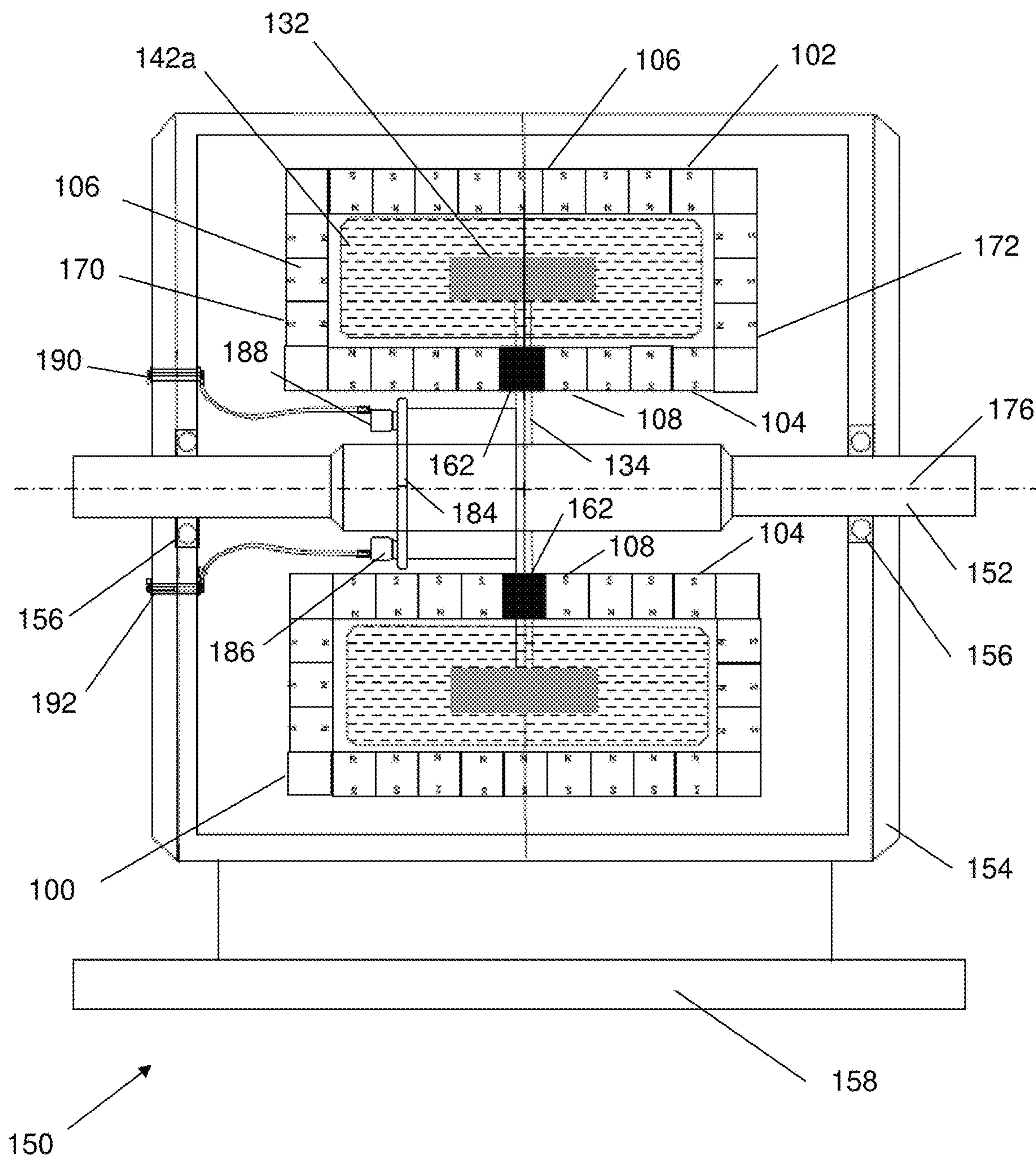

Fig. 14



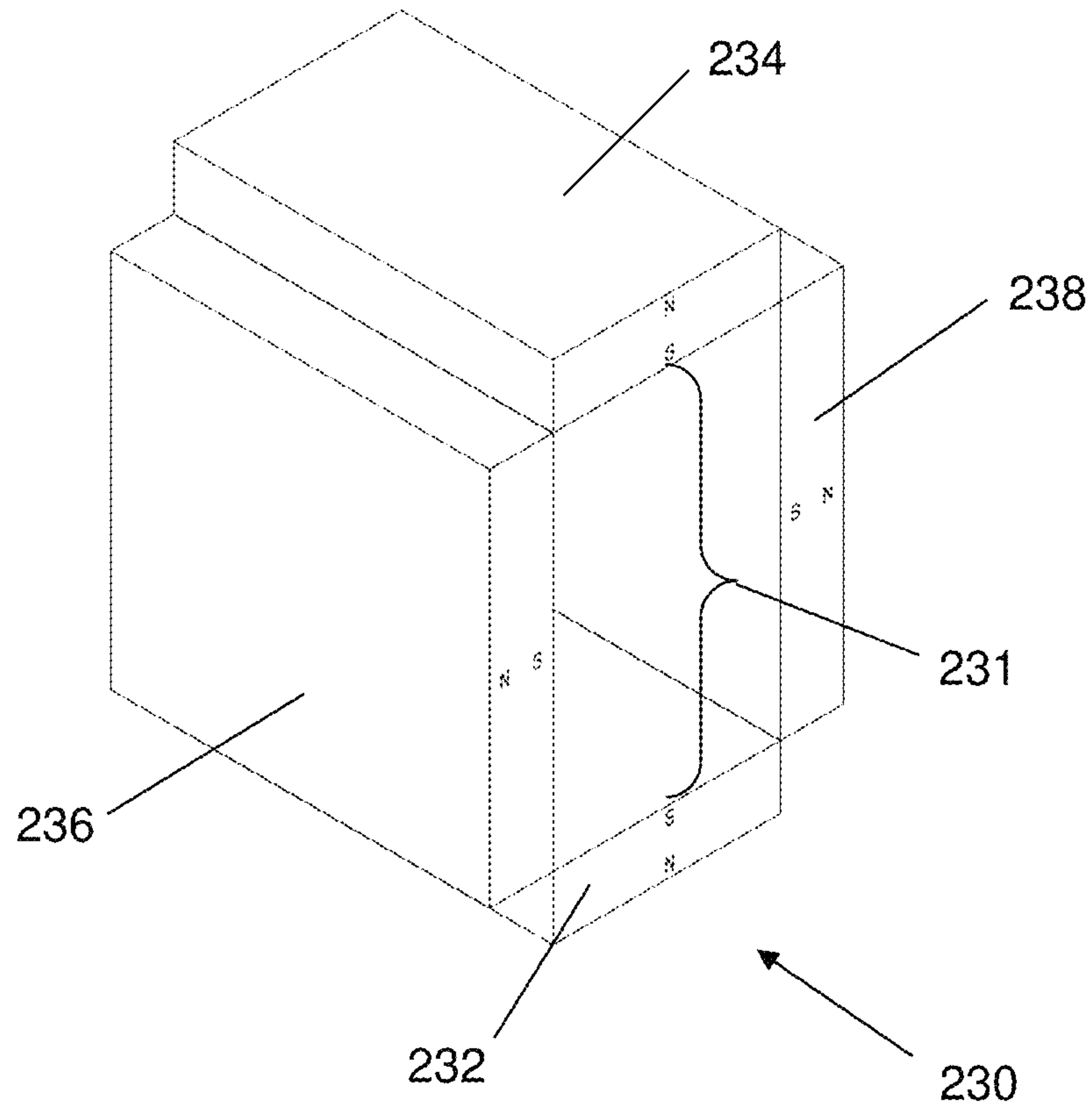

Fig. 15

**MULTI-TUNNEL ELECTRIC  
MOTOR/GENERATOR**

## RELATED APPLICATIONS

This application is a Continuation of U.S. patent application Ser. No. 16/374,132, filed Apr. 3, 2019, entitled "An Improved Multi-Tunnel Electric Motor/Generator," which is a Continuation of U.S. patent application Ser. No. 15/657,173, entitled "An Improved Multi-Tunnel Electric Motor/Generator," filed Jul. 23, 2017, which is a Continuation of U.S. patent application Ser. No. 15/492,529, entitled "An Improved Multi-Tunnel Electric Motor/Generator," filed Apr. 20, 2017, which is a Continuation-in-Part of PCT International application serial number PCT/US2016/026776, entitled "An Improved Multi-Tunnel Electric Motor/Generator," filed on Apr. 8, 2016, which claims the benefit of U.S. provisional patent application Ser. No. 62/173,349 entitled "Multi-Tunnel Electric Motor/Generator," filed on Jun. 9, 2015; U.S. provisional patent application Ser. No. 62/167,412 entitled "Multi-Tunnel Electric Motor/Generator," filed on May 28, 2015; and U.S. provisional patent application Ser. No. 62/144,654 entitled "Multi-Tunnel Electric Motor/Generator," filed on Apr. 8, 2015, and said U.S. patent application Ser. No. 15/492,529, is also a Continuation-in-Part of U.S. patent application Ser. No. 14/866,788, entitled "Brushless Electric Motor/Generator," filed on Sep. 25, 2015, which claims the benefit of U.S. provisional patent application Ser. No. 62/056,389, entitled "DC Electric Motor/Generator with Enhanced Permanent Magnet Flux Densities," filed on Sep. 26, 2014; U.S. provisional patent application Ser. No. 62/055,615, entitled "DC Electric Motor/Generator with Enhanced Permanent Magnet Flux Densities," filed on Sep. 25, 2014; and U.S. provisional patent application Ser. No. 62/055,612, entitled "DC Electric Motor/Generator with Enhanced Permanent Magnet Flux Densities," filed on Sep. 25, 2014; and which is a Continuation-in-Part of U.S. patent application Ser. No. 13/848,048, entitled "DC Electric Motor/Generator with Enhanced Permanent Magnet Flux Densities," filed on Mar. 20, 2013, which claims the benefit of U.S. provisional patent application Ser. No. 61/613,022, entitled "Electric Motor/Generator," filed Mar. 20, 2012, of which all of the disclosures are hereby incorporated by reference for all purposes.

This application is also commonly owned with the following U.S. patent applications: U.S. patent application Ser. No. 15/413,228, entitled "Brushless Electric Motor/Generator," filed on Jan. 23, 2017; U.S. patent application Ser. No. 14/866,787, entitled "Brushed Electric Motor/Generator," filed on Sep. 25, 2015; U.S. patent application Ser. No. 14/608,232, entitled "Brushless Electric Motor/Generator," filed on Jan. 29, 2015; U.S. patent application Ser. No. 14/490,656, entitled "DC Electric Motor/Generator with Enhanced Permanent Magnetic Flux Densities," filed on Sep. 18, 2014, the disclosures of which are hereby incorporated by reference for all purposes.

## TECHNICAL FIELD

The invention relates in general to a new and improved electric motor/generator, and in particular to an improved system and method for producing rotary motion from an electro-magnetic motor or generating electrical power from a rotary motion input.

## BACKGROUND INFORMATION

Electric motors use electrical energy to produce mechanical energy, very typically through the interaction of mag-

netic fields and current-carrying conductors. The conversion of electrical energy into mechanical energy by electromagnetic means was first demonstrated by the British scientist Michael Faraday in 1821 and later quantified by the work of Hendrik Lorentz.

In a traditional electric motor, a central core of tightly wrapped current carrying material creates magnetic poles (known as the rotor) spins or rotates at high speed between the fixed poles of a magnet (known as the stator) when an electric current is applied. The central core is typically coupled to a shaft which will also rotate with the rotor. The shaft may then be used to drive gears and wheels in a rotary machine and/or convert rotational motion into motion in a straight line.

Generators are usually based on the principle of electromagnetic induction, which was discovered by Michael Faraday in 1831. Faraday discovered that when an electrical conducting material (such as copper) is moved through a magnetic field (or vice versa), an electric current will begin to flow through that material. This electromagnetic effect induces voltage or electric current into the moving conductors.

Current power generation devices such as rotary alternator/generators and linear alternators rely on Faraday's discovery to produce power. In fact, rotary generators are essentially very large quantities of wire spinning around the inside of very large magnets. In this situation, the coils of wire are called the armature because they are moving with respect to the stationary magnets (which are called the stators). Typically, the moving component is called the armature and the stationary components are called the stator or stators.

In most conventional motors, both linear and rotating, enough power of the proper polarity must be pulsed at the right time to supply an opposing (or attracting) force at each pole segment to produce a particular torque. In conventional motors at any given instant only a portion of the coil pole pieces is actively supplying torque.

With conventional motors, a pulsed electrical current of sufficient magnitude must be applied to produce a given torque/horsepower. Horsepower output and efficiency then is a function of design, electrical input power plus losses.

With conventional generators, an electrical current is produced when the rotor is rotated. The power generated is a function of flux strength, conductor size, number of pole pieces and speed in RPM. However output is a sinusoidal output which inherently has losses similar to that of conventional electric motors.

Specifically, the pulsed time varying magnetic fields produces undesired effects and losses, i.e. iron hysteresis losses, counter-EMF, inductive kickback, eddy currents, inrush currents, torque ripple, heat losses, cogging, brush losses, high wear in brushed designs, commutation losses and magnetic buffeting of permanent magnets. In many instances, complex controllers are used in place of mechanical commutation to address some of these effects.

Additionally, in motors or generators, some form of energy drives the rotation and/or movement of the rotor. As energy becomes more scarce and expensive, what is needed are more efficient motors and generators to reduce energy consumption, and hence costs.

## SUMMARY

In response to these and other problems, there is presented various embodiments disclosed in this application, including methods and systems of increasing flux density by perma-



nent magnet manipulation using multiple magnetic tunnels. Disclosed are various embodiments for a motor/generator comprising: a plurality of coils radially positioned about a coil assembly, a plurality of magnetic tunnels forming a relative rotational path for the coil assembly, wherein the all of plurality of magnets forming each magnetic tunnel have like poles facing inward toward the interior of the magnetic tunnel or facing outward away from the interior of the magnetic tunnel such that each magnetic field of any magnetic tunnel is of an opposite polarity to the magnetic field of an adjacent magnetic tunnel.

These and other features, and advantages, will be more clearly understood from the following detailed description taken in conjunction with the accompanying drawings. It is important to note the drawings are not intended to represent the only aspects of the invention.

#### BRIEF DESCRIPTION OF THE DRAWINGS

FIG. 1A is an exploded view of one embodiment of a motor/generator component according to certain aspects of the present disclosure.

FIG. 1B is a detailed exploded view of certain elements of the motor/generator component of FIG. 1A.

FIG. 2 is a detailed isometric view of a magnetic cylinder/stator element or magnetic cylinder/rotor element of the motor/generator component illustrated in FIG. 1A.

FIG. 3 is an exploded view of the magnetic cylinder/stator element or the magnetic cylinder/rotor element of FIG. 2.

FIG. 4A is an isometric view of a partial coil assembly element.

FIG. 4B is a detailed perspective view of a single tooth element of the partial coil assembly element illustrated in FIG. 4A.

FIG. 4C is a detailed perspective view of an alternative embodiment of a single tooth element of the partial coil assembly element illustrated in FIG. 4A.

FIG. 4D is an isometric view of the partial coil assembly element of FIG. 4A coupled to a plurality of coil windings.

FIG. 4E is an isometric view of a coil assembly.

FIG. 5 illustrates one embodiment of a toroidal magnetic cylinder.

FIG. 6 illustrates a conceptual two-dimensional radial segment of a toroidal magnetic cylinder.

FIG. 7A is a detailed isometric view of one embodiment of a radial portion or radial segment of the toroidal magnetic cylinder illustrated in FIG. 5.

FIG. 7B is a detailed isometric view of one embodiment of the radial portion or radial segment illustrated in FIG. 7A with the addition of direction arrows.

FIG. 7C is a detailed isometric view of one embodiment of the radial portion or radial segment illustrated in FIG. 7A with the addition of a portion of a coil assembly illustrated in FIG. 4E.

FIG. 7D illustrates one embodiment of the coil assembly of FIG. 4E positioned within the toroidal magnetic cylinder of FIG. 5.

FIG. 8 illustrates the magnetic cylinder of FIG. 7D coupled to a back iron circuit with a portion of the side back iron circuit positioned in an exploded view for clarity.

FIG. 9A is an exploded view of the magnetic cylinder and back iron circuit of FIG. 8 coupled to additional structures to form a motor/generator.

FIG. 9B is an isometric view of the magnetic cylinder and back iron circuit of FIG. 8 coupled to additional structures to form a motor/generator.

FIG. 10 is an alternative exploded view of the motor/generator of FIGS. 9A and 9B illustrating the stationary and rotating elements.

FIG. 11 is a perspective view of a rotor hub and certain elements of the motor/generator.

FIG. 12A is an isometric and partial section view of a toroidal magnetic cylinder.

FIG. 12B is a detailed partial section view of the toroidal magnetic cylinder of FIG. 12A illustrating the planar magnetic fields or flux walls generated within the cylinder interior.

FIG. 13 is a conceptualized isometric view of a rotor hub assembly.

FIG. 14 is a conceptualized longitudinal view of an electric motor/generator assembly.

FIG. 15 is a detailed isometric view of a portion of an alternative embodiment of a magnetic ring.

#### DETAILED DESCRIPTION

Specific examples of components, signals, messages, protocols, and arrangements are described below to simplify the present disclosure. These are, of course, merely examples and are not intended to limit the invention from that described in the claims. Well-known elements are presented without detailed description in order not to obscure the present invention in unnecessary detail. For the most part, details unnecessary to obtain a complete understanding of the present invention have been omitted inasmuch as such details are within the skills of persons of ordinary skill in the relevant art. Details regarding conventional control circuitry, power supplies, or circuitry used to power certain components or elements described herein are omitted, as such details are within the skills of persons of ordinary skill in the relevant art.

When directions, such as upper, lower, top, bottom, clockwise, or counter-clockwise are discussed in this disclosure, such directions are meant to only supply reference directions for the illustrated figures and for orientation of components in the figures. The directions should not be read to imply actual directions used in any resulting invention or actual use. Under no circumstances, should such directions be read to limit or impart any meaning into the claims.

##### Motor/Generator Element and Back Iron Circuit

FIG. 1A is an exploded isometric view of a motor/generator element 100 illustrating a first portion 202 of a back iron circuit 200, a second portion 204 of the back iron circuit 200, a rotor hub 300, and a magnetic disc assembly 400.

The back iron circuit 200 is theoretically optional. It serves to strengthen magnetic elements (described below) and constrain the magnetic circuit to limit reluctance by removing or reducing the return air path. The first portion 202 of the back iron circuit 200 comprises a first outer cylindrical wall 206 made of a suitable back iron material as described below. When the motor/generator element 100 is assembled, a first inner cylindrical wall 208 is concentrically positioned within the first outer cylindrical wall 206. A first flat side wall 210 which is also made of back iron material is positioned longitudinally next to the first outer cylindrical wall 206 and the first inner cylindrical wall 208.

A second portion of the back iron circuit includes a second inner cylinder wall 218 concentrically positioned within a second outer cylindrical wall 216 (when the motor/generator element 100 is assembled). A second flat side wall 220 of back iron material is positioned longitudinally next to the second outer cylindrical wall 216 and the second inner



## 5

cylindrical wall **218**. In certain embodiments, the second inner cylinder wall **218** and second outer cylinder wall **216** have a plurality of longitudinal grooves sized to accept and support a plurality of magnets as described below with respect to FIG. **1B**.

For purposes of this application the term “back iron” may refer to iron, an iron alloy, any ferrous compound or alloy, such as stainless steel, any nickel or cobalt alloy, laminated steel, laminated silicon steel, or any laminated metal comprising laminated sheets of such material, or a sintered specialty magnetic powder. In some embodiments, the ring core **504** may be hollow or have passages defined therein to allow for liquid or air cooling.

In certain embodiments, there is a radial gap **212** between the first outer wall **206** and the first side wall **210**. The radial gap **212** allows for the passage of a support structure, control wires and electrical conductors (not shown) into the magnetic disc assembly **400** as well as for heat dissipation and/or a thermal control medium. In other embodiments, the gap **212** may be defined within the first outer wall **206** or between the first outer wall **206** and the second outer wall **216**. In yet other embodiments, the gap **212** may be located in other locations to optimize performance.

FIG. **1B** is a detailed isometric view of the first portion **202** of the back iron circuit illustrating the first inner cylindrical wall **208**, positioned within the first outer cylinder wall **206**. A plurality of inner longitudinal grooves **240** are defined and radially spaced around an inner surface **242** of the first outer cylinder wall **206**. Similarly, a plurality of outer longitudinal grooves **244** are defined and radially spaced around an outer surface **246** of the first inner cylinder wall **208**.

As will be described in detail below, a plurality of outer magnets forming a portion of an outer magnetic wall **406a** (from the magnetic disc **400** discussed below) are sized to fit within the plurality of inner longitudinal grooves **240**. Similarly, a plurality of inner magnets forming a portion of an inner magnetic wall **408a** are sized to fit within the plurality of outer longitudinal grooves **244** defined within the outer surface **246** of the first inner cylinder wall **208**. Similar or identical grooves or surfaces are found in the second portion **204** of the back iron circuit **200**, and thus, will not be separately described in this disclosure.

When the motor/generator element **100** is assembled, the first portion **202** of the back iron circuit **200** and the second portion **204** of the back iron circuit physically support and surround the magnetic disc **400**. The first inner wall **208** and second inner wall **218** also radially surrounds and is radially coupled to the rotor hub **300**. In certain embodiments, the rotor hub **300** positions and structurally supports certain components of the back iron circuit **200** (which in turn, supports the magnetic components of the magnetic disc **400**).

#### Magnetic Disc Assembly

FIG. **2** is a detailed isometric view of the assembled magnetic disc **400** of FIG. **1**. FIG. **3** is an exploded view of the magnetic disc **400**. In the embodiment illustrated in FIGS. **2** and **3**, with respect to a longitudinal axis **401**, there is a top or first axial or side wall of magnets **402**. Similarly there is a bottom or second axial or side wall of magnets **404**. An outer cylindrical wall of magnets **406** is longitudinally positioned between the first axial or side wall **402** and the second axial or side wall of magnets **404**. In certain embodiments, the outer cylindrical wall of magnets **406** comprises two pluralities of magnets **406a** and **406b** which are sized to couple with the back iron walls **206** and **216**, as described above with respect to FIG. **1B**.

## 6

An inner cylindrical wall of magnets **408** is also longitudinally positioned between the first axial or side wall **402** and the second axial or side wall of magnets **404** and concentrically positioned within the outer cylindrical wall of magnets **406**. In certain embodiments, the inner cylindrical wall of magnets **408** comprises two pluralities of magnets **408a** and **408b** which are sized to couple with the back iron walls **208** and **218**, as described above in reference to FIG. **1B**.

In certain embodiments, the magnets forming the axial side walls **402-404** and cylindrical walls **408-406** discussed herein may be made of out any suitable magnetic material, such as: neodymium, Alnico alloys, ceramic permanent magnets, or electromagnets. The exact number of magnets or electromagnets will be dependent on the required magnetic field strength or mechanical configuration. The illustrated embodiment is only one way of arranging the magnets, based on certain commercially available magnets. Other arrangements are possible, especially if magnets are manufactured for this specific purpose.

#### Coil Assembly

When the motor/generator **100** is assembled, a coil assembly **500** is concentrically positioned between the outer cylinder wall **406** and the inner cylinder wall **408**. The coil assembly **500** is also longitudinally positioned between the first axial side wall **402** and the second axial side wall **404**. In certain embodiments, the coil assembly **500** may be a stator. In yet other embodiments, the coil assembly **500** may be a rotor.

Turning now to FIG. **4A**, there is an isometric view of a coil assembly support **502**, which in one embodiment, may be a portion of a stator used in conjunction with a rotor formed by the magnetic axial walls **402-404** and magnetic longitudinal walls **406-408** and the back iron circuit portions **202** and **204** discussed above in reference to FIGS. **1A** through **3**. In certain embodiments, the coil assembly support **502** comprises a cylindrical or ring core **504** coupled to a plurality of teeth **506** radially spaced about the ring core. FIG. **4A** shows a portion of teeth **506** removed so that the ring core **504** is visible.

In certain embodiments, the ring core **504** and coil assembly support **502** may be made out of iron or back iron materials so that it will act as a magnetic flux force concentrator. Some back iron materials are listed above. However, other core materials maybe used when design considerations such as mechanical strength, reduction of eddy currents, cooling channels, etc. are considered.

In yet other embodiments, the coil assembly support **502** may be made from a composite material which would allow it to be sculptured to allow for cooling and wiring from inside. The composite material may be formed of a “soft magnetic” material (one which will produce a magnetic field when current is applied to adjoining coils). Soft magnetic materials are those materials which are easily magnetized or demagnetized. Examples of soft magnetic materials are iron and low-carbon steels, iron-silicon alloys, iron-aluminum-silicon alloys, nickel-iron alloys, iron-cobalt alloys, ferrites, and amorphous alloys.

In certain embodiments, a wiring connection (not shown) can also be formed in the shape of a “plug” for coupling to the stator teeth. Thus, certain teeth of the plurality of teeth **506** may have holes **508** for such plugs (or wires) defined on one side for attachment to a structural support in embodiments where the coil assembly **500** acts as a stator as described below in reference to FIGS. **9A-11**.

One embodiment of an individual tooth **506a** and a small portion of the ring core **504** are illustrated in FIG. **4B**. The



tooth **506a** may be made from a material similar to the material forming the core **504**, for example, iron, a composite magnetic material, or laminated steel. In the illustrated embodiment, each tooth **506a** extends from the ring core **504** in radial and vertical (or longitudinal) directions. Thus, each tooth **506a** comprises an outer radial portion **510** extending radially away from the longitudinal axis **401** (see FIG. 4A), an inner radial portion **512** extending radially toward the longitudinal axis **401**, a top vertical or longitudinal portion **514** extending in one vertical or longitudinal direction, and a bottom vertical or longitudinal portion **516** extending in the opposing longitudinal direction. The ring core **504** supports the individual tooth **506a** as well as other teeth as described above in reference to FIG. 4A.

In certain embodiments, an exterior fin **520** couples to an exterior portion of the outer radial portion **510** and extends outward from the outer radial portion **510** in both circumferential or tangential directions with respect to the longitudinal axis **401**. Similarly, an interior fin **522** couples to an interior portion of the inner radial portion **512** and extends outward from the inner radial portion **512** in both tangential directions.

An alternative embodiment of an individual tooth **506a'** and a small portion of the ring core **504** are illustrated in FIG. 4C. The tooth **506a'** is similar to the tooth **506a** described above in reference to FIG. 4B except that the tooth **506a'** also has radial or horizontal fins extending from the top vertical portion **514** and the lower vertical portion **516**. Specifically, a top radial fin **518** extends in both horizontal circumferential (or tangential) directions from the top horizontal portion **514** and connects the exterior fin **520** to the interior fin **522**. Similarly, a bottom radial fin **519** extends in both horizontal circumferential or tangential directions from the bottom vertical portion **516** and connects the exterior fin **520** to the interior fin **522** as illustrated in FIG. 4C.

Adjacent teeth **506** (or adjacent teeth **506a'**) supported by the core ring **504** form radial slots **524** within the coil assembly support structure **502**, as illustrated in FIG. 4A. A plurality of coils or coil windings **526** may be positioned radially about the ring core **504** and within the slots **524** as illustrated in FIG. 4D. FIG. 4D illustrates the plurality of coil windings **526** distributed about the ring core **504** with a number of teeth **506** removed for clarity. In contrast, FIG. 4E illustrates a complete coil assembly **500** showing all of the teeth **506** and coil windings **526** positioned within the slots **524**.

#### Coils or Coil Windings

Each individual coil **526** in the coil assembly **500** may be made from a conductive material, such as copper (or a similar alloy) wire and may be constructed using conventional winding techniques known in the art. In certain embodiments, concentrated windings may be used. In certain embodiments, the individual coils **526** may be essentially cylindrical or rectangular in shape being wound around the ring core **504** having a center opening sized to allow the individual coil **526** to surround and be secured to the ring core **504**. Thus, in such embodiments, the winding does not overlap.

By positioning the individual coils **526** within the slots **524** defined by the teeth **506**, the coils are surrounded by the more substantial heat sink capabilities of the teeth which, in certain embodiments, can incorporate cooling passages directly into the material forming the teeth. This allows much higher current densities than conventional motor geometries. Additionally, positioning the plurality of coils **526** within the slots **524** and between teeth **506** reduces the

air gap between the coils. By reducing the air gap, the coil assembly **500** can contribute to the overall torque produced by the motor or generator.

In certain embodiments, the horizontal fins **518** and **519**, the circumferential fins **520** and **522** of the teeth **506a** or **506a'** of the coil assembly reduce the air gaps between the magnetic material and the coil structure to allow flux forces to flow in the proper direction when the coils are energized and the coil assembly **500** begins to move relative to the magnetic tunnel. Thus, all portions of the coil support assembly **502** contribute to the overall torque developed by the system. In yet other embodiments, the teeth **506** may not have any fins. Although the fins create a more efficient design, the fins complicate the fabrication of the coil windings, thereby increasing the motor costs. Unconventional winding techniques may be used when using fins—such as fabricating the coil assembly support **502** in conjunction with the coil windings. In some embodiments, a winding may be started at the center of the conductor length with two bobbins rotating in opposite directions around the core with the wound segments in separate parallel planes. This method has the advantage of both conductor ends exiting at the same location and eliminating compression of one conductor length exiting from the center of the winding.

The number of individual coils **526** can be any number that will physically fit within the desired volume and of a conductor length and size that produces the desired electrical or mechanical output as known in the art. In yet other embodiments, the coils **526** may be essentially one continuous coil, similar to a Gramme Ring as is known in the art.

The windings of each coil **526** are generally configured such that they remain transverse or perpendicular to the direction of the relative movement of the magnets (e.g. the rotor) comprising the coil assembly **500** and parallel with the longitudinal axis **401**. In other words, the coil windings are positioned such that their sides are parallel with the longitudinal axis **401** and their ends are radially perpendicular to the longitudinal axis. As will be explained below, the coil windings are also transverse with respect to the magnetic flux produced by the individual magnets of the rotor at their interior face as described below in reference to FIG. 7A to 7C. Consequently, the entire coil winding or windings may be used to generate movement (in motor mode) or voltage (in generator mode).

In sum, the windings are placed in an axial/radial direction in multiple slots **524** (e.g. 48 slots) which can form a single phase or multi-phase winding. The radial/axial placement of the windings may create a maximum force in the direction of motion for all four sides of the windings.

#### The Magnetic Cylinder

FIG. 5 is an isometric view of the magnetic disc assembly **400** with the coil assembly **500** removed for clarity. The magnets of the magnetic disc assembly **400** form a toroidal magnetic cylinder **430** defining a toroidal magnetic tunnel **440** positioned about the longitudinal axis **401**. As described previously, the toroidal magnetic cylinder **430** includes: the top axial or side wall of magnets **402**, the bottom or second axial or side wall of magnets **404**, the outer cylindrical wall **406** of magnets positioned longitudinally between the first side wall **402** of magnets and the second side wall **404** of magnets; and the inner cylindrical wall **408** of magnets positioned concentrically within the outer cylindrical wall **406** of magnets. In certain embodiments, the outer cylindrical wall **406** may be formed by two pluralities of magnets **406a** and **406b**, where each plurality of magnets are sized to couple with the back iron circuit walls **206** and **216**, respectively. Similarly, the inner cylindrical wall **408** may be



formed by two pluralities of magnets **408a** and **408b**, where each plurality of magnets are sized to couple with the back iron circuit walls **208** and **218**, respectively.

As discussed above with respect to the back iron circuit **200**, depending on the embodiment, there may be a radial circumferential slot **410** defined by the outer longitudinal ring of magnets **406** and one of the side walls **402** or **404** to accommodate a support structure for the stator and/or control wires, conductors, ventilation and/or a cooling medium. In other embodiments, there may be a circumferential slot separating the outer cylinder wall **406** of magnets into a first longitudinal ring **406a** and a second longitudinal ring **406b** of magnets. In yet other embodiments, there may be a circumferential slot separating the inner cylinder wall **408** of magnets into a first longitudinal ring **408a** and a second longitudinal ring **408b** of magnets. In yet further embodiments, a circular slot may be defined anywhere within the side walls **402** or **404**.

In the embodiment illustrated in FIG. 5, the magnetic side walls **402**, **404** and the magnetic cylindrical walls **406** and **408** may be made from commercially available magnetic segments. In other embodiments, plate magnets may be customized for a particular application. The number of segments forming the rings or walls will depend on the particular design and performance characteristics for a particular application.

Note that in the illustrative embodiment of FIG. 5, there are eight radial “slices” or magnetic segments **420** forming a complete toroidal magnetic cylinder **430**. However, the exact number of segments depends on the size, performance characteristics, and other design factors.

FIG. 6 is a cross-sectional conceptual view of one embodiment of a radial “slice” **150** of a magnetic cylinder which is conceptually similar to the radial segment **420** of the toroidal magnetic cylinder **430** of FIG. 5 above. In certain embodiments, the partial magnetic cylinder **150** comprises an outer curved wall **102** and an inner curved wall **104**. The outer curved wall **102** and inner curved wall **104** may be made with a plurality of magnets. In a lateral section view, such as illustrated in FIG. 6, it can be seen that the outer curved wall **102** is comprised of a plurality of magnets **106**, comprising individual magnets, such as magnets **106a**, **106b**, **106c**, etc. Similarly, the inner curved wall **104** may be comprised with a plurality of magnets **108**, comprising individual magnets **108a**, **108b**, etc. It should be noted that only one polarity of the magnets are utilized within (or facing into) the magnetic cylinder portion **150**. For instance in the illustrative embodiment of FIG. 6, the north poles of the magnets **106** are each pointing radially towards the center or longitudinal axis **401** (which is coming out of the page in FIG. 6). On the other hand, the north poles of the magnets **108** each point radially away from the longitudinal axis **401** and towards an interior cavity or tunnel **124** of the partial magnetic cylinder **150**.

In certain embodiments, there may be a central core, such as an iron core (not shown in FIG. 6), where a portion of the core is positioned within the interior tunnel **124** between the outer wall **102** and the inner wall **104**. In certain embodiments, the core may be used as a magnetic flux line concentrator.

When the plurality of magnets **106** and **108** are arranged into the outer wall **102** and inner wall **104** to form a partial cylinder **150**, the density of the magnetic flux forces will form particular patterns as represented in a conceptual manner by the flux lines **112** illustrated in FIG. 6. The actual shape, direction, and orientation of the flux lines **112** depend

on factors such as the use of an interior retaining ring, a center core, a back iron circuit, material composition and/or configuration.

To generally illustrate this magnetic arrangement, the flux line **112a** (or flux lines) from the magnet **106a** of the exterior wall **102** tends to flow from the north pole (interior face) of the magnet in a perpendicular manner from the face of the magnet into and through the interior tunnel **124** of the partial cylinder **150**, exiting through the open end **114** into the open area **115**, then flow around the exterior of the partial cylinder **150**, and back to an exterior face of the magnet **106a** containing its south pole.

Similarly, the flux line **112b** from the magnet **106b** of the exterior wall **102** tends to flow from the north pole of the magnet in a perpendicular manner from the face of the magnet into and through the interior tunnel **124** of the partial cylinder **150**, exiting through the open end **114** into the open space **115**, then flow around the exterior of the cylinder **150**, and back to the face of the magnet **106b** containing its south pole. Although only a few flux lines **112** are illustrated for purposes of clarity, each successive magnet in the “top portion” of the plurality of magnets will produce similar flux lines. Thus, the magnetic flux forces for each successive magnet in the plurality of magnets **106** tend to follow these illustrative flux lines or patterns for each successive magnetic disc in the plurality of magnets **106** until the magnets at the open ends **114** or **116** of the partial magnetic cylinder **150** are reached.

As illustrated, the magnet **106a** is positioned circumferentially adjacent to the magnet **106b**. In turn, another magnet **106c** is positioned circumferentially adjacent to the magnet **106b**. Additional magnets in the group **106** may be positioned circumferentially adjacent to others until the open end **114** is reached. The flux lines **112** generated from the adjacent magnetic poles in the magnetic group **106** are concentrated at the open ends of the tunnel segment where they turn back towards an exterior face of the respective magnet.

Magnets in the “bottom portion” of the plurality of magnets **106**, such as magnet **106d** tend to generate flux lines **112d** from the magnet **106d** on the exterior wall **102** which tends to flow from the north pole (interior face) of the magnet in a perpendicular manner from the face into and through the interior tunnel **124** of the partial cylinder **150**, exiting through an open end **116** into the open space, then flow around the exterior of the partial cylinder **150**, and back to an exterior face of the magnet **106d** containing its south pole. Although only a few flux lines on the opposing side of the partial cylinder **150** are illustrated for purposes of clarity, each successive or magnet in the plurality of magnets will produce similar flux lines which will also be concentrated at the opening **116** as described above. In embodiments with an iron core, the flux lines will generally flow in a similar manner, but will tend to flow through the core and be concentrated within the core. Thus, in certain embodiments, the core may act as a flux concentrator.

The interior magnetic wall **104** also produces flux forces, which also may be illustrated by flux lines, such as exemplary flux lines **118**. For instance, the flux line **118a** from the magnet **108a** on the interior wall **104** tends to flow from interior face (e.g., the north pole) in a perpendicular manner from the face of the magnet, into and through the interior tunnel **124** of the partial cylinder **150**, out the open end **114** (or open end **116**) and into the open space **115**, then around the interior wall **104** to the face of the magnet **108a** containing its south pole.



The magnetic flux forces for each successive magnet in the plurality of magnets **108** tend to follow these illustrative flux lines or patterns **118** for each successive magnet in the plurality of magnets **108** until the open ends **114** or **116** of the partial magnetic cylinder **150** are reached. Thus, the flux forces produced by the magnets of the interior wall **104** of the partial cylinder **150** have an unobstructed path to exit through one of the open ends of the partial cylinder and return to its opposing pole on the exterior or interior of the cylinder.

As discussed above, the magnetic flux lines **112** and **118** will tend to develop a concentrating effect and the configuration of the exterior magnetic cylinder manipulates the flux lines **112** and **118** of the magnets in the partial magnetic cylinder **150** such that most or all of the flux lines **112** and **118** flow out of the open ends **114** and **116** of the partial cylinder. In conventional configurations, the opposing poles of the magnets are usually aligned longitudinally. Thus, the magnetic flux lines will “hug” or closely follow the surface of the magnets. So, when using conventional power generating/utilization equipment, the clearances must usually be extremely tight in order to be able to act on these lines of force. By aligning like magnetic poles (e.g. (all south or all north) radially with respect to the longitudinal axis **401**, the magnetic flux lines **112** and **118** tend to radiate perpendicularly from the surface of the magnets. This configuration allows for greater tolerances between coils and the partial magnetic cylinder **150**.

The partial magnetic cylinder **150** is a simplified two dimensional section illustration of a three dimensional magnetic arrangement concept. The three dimensional arrangement also has magnetic top and bottom magnetic walls with their north magnetic poles facing the interior of the tunnel **124** (not shown). Additionally, similar results can be obtained by replacing the plurality of magnets **106** with a single curved plate magnet magnetized in a similar manner (e.g., a north pole is formed on the interior face and a south pole is formed on an exterior face). Similarly, the plurality of magnets **108** may be replaced with a single curved plate magnet having its north pole on the surface facing the interior tunnel **124** and the south pole on the surface facing towards the longitudinal axis **401**.

For instance, FIG. 7A is a detailed perspective view of the radial segment **420** of the toroidal magnetic cylinder **430** (see FIG. 5) defining a portion of the magnetic tunnel **440** as discussed above in reference to FIG. 5. The radial segment **420** is conceptually similar to the partial magnetic cylinder **150** because the radial segment **420** has an outer curved magnetic wall **406** and an inner curved magnetic wall **408**. In addition to the curved or cylindrical magnetic walls **406** and **408**, there are also magnetic axial or lateral walls **402** and **404** which in this illustrated embodiment may be made of wedge shaped plate magnets.

The magnetic poles of the magnets forming the outer cylindrical wall **406** and the inner cylindrical wall **408** have their magnetic poles orientated radially pointing towards the longitudinal axis **401** (see FIG. 5). In contrast, the magnetic poles of the magnets forming the top or first axial wall **402** and the bottom or second axial wall **404** have their magnetic poles orientated or aligned parallel with the longitudinal axis **401**. The individual magnets in the magnetic walls **402**, **404**, **406**, and **408** all have their similar or “like” (e.g. north) magnetic poles orientated either towards or away from the interior of the tunnel **440** of the toroidal magnetic cylinder **430** to form a “closed” magnetic tunnel **440**. The closed magnetic tunnel **440** runs circumferentially from the open

end or exit **412** to the open end or exit **414** (similar to the tunnel **124** and open ends **114** and **116** discussed above with reference to FIG. 6).

For purposes of this disclosure and to illustrate the orientation of magnetic poles at the surfaces of the magnets forming the radial segment **420**, the top axial wall **402** is labeled with an “S” on its exterior top face to indicate that in this particular configuration, the south pole of the magnet (or magnets) forming the top axial wall **402** faces away from the tunnel **440**. Thus, the north pole of the magnet **402** faces towards the tunnel segment **440**. Similarly, the lower axial or side wall **404** is labeled with a “N” on its interior side face to indicate that the north pole of the magnet forming the side wall **404** is facing towards the tunnel segment **440** (however, in this view the “N” is partially obscured). The two magnets forming the outer longitudinal wall **406** are labeled with an “N” on their interior surfaces to indicate that their north magnetic poles face the interior of the magnetic tunnel **440**. In contrast, the two magnets forming the inner longitudinal wall **408** are labeled with an “S” on their exterior surfaces to indicate that their south poles are facing away from the tunnel **440**. Thus, their north poles face towards the tunnel **440**.

In this illustrative embodiment of the radial segment **420**, all the magnets of the walls **402**, **404**, **406** and **408** have their north poles facing towards the interior or tunnel **440**. So, the radial segment **420** has an NNNN magnetic pole configuration. Thus, the magnetic forces which tend to repel each other—forcing the magnetic flux circumferentially along the tunnel **440** in a circumferential direction and out the tunnel exits **412** and **414** similar to that described above in reference to FIG. 6. FIG. 7B is an illustration of the radial segment **420**, but with the addition of directional arrows. Arrow **422** illustrates a circumferential direction and the arrow **424** illustrates a radial direction.

The term “closed magnetic tunnel” as used in this disclosure refers to using an arrangement of the magnets forming a tunnel that “forces” or “bends” the majority of the magnetic flux “out of plane” or circumferentially through the tunnel or interior cavity then out through one of the openings **412** or **414** as illustrated by the circumferential arrow **422** of FIG. 7B. In contrast, if the magnetic tunnel were not magnetically “closed,” the flux forces would generally flow in a radial manner in the direction of the radial or lateral arrow **424** (or in a plane represented by the arrow **424**). Conventional motors usually allow flux forces to flow in a radial direction as illustrated by the arrow **424**.

Turning now to FIG. 7C, there is illustrated an isometric view of radial segment **420** with a portion of the coil assembly **500** positioned within the interior of the segment or tunnel **440** (FIG. 5B). The rest of the coil assembly **500** has been removed for clarity. In an un-energized state, the magnetic flux tends to flow from the north poles of the magnetic walls **402**, **404**, **406** and **408** into the coil assembly **500** and to the coil core **504**. Because of opposing magnetic forces, the magnetic flux continues to flow circumferentially through the coil core **504** until the flux reaches an opening (for instance, open end **414**) of the tunnel **440**. The flux then bends back around an open end (e.g. open end **414**) of the radial segment **420** to an exterior face of the respective magnetic wall containing a south pole. Arrows **426** of FIG. 7C are meant to illustrate the three dimensional flux path as the flux reaches an open end **412** or **414** of the radial segment and bends back around to an exterior face (or in this case, the south pole) of the appropriate magnetic wall. Thus, the radial segment **420** generates a flux field which is conceptually similar to the flux fields **112** and **118** discussed above in



reference to FIG. 6 (In situations where a radial segment **420** is adjacent to another radial segment of an opposite magnetic polarity configuration, the flux lines could extend into the adjacent partial toroidal magnetic cylinder).

In certain embodiments, the core **504**/coil assembly **500** may generate its own magnetic field fluxes as current is introduced into the supporting coils **526** (FIG. 4D). The majority of magnetic field fluxes are also constrained and channeled to interact with the magnetic flux generated from the magnetic tunnel (e.g., from permanent magnets) in a similar manner to that described above. Thus, all portions of the coil **504**/coil assembly **500** may interact with the flux lines of the magnetic tunnel **440** to allow full utilization of the flux lines and all forces working together in the direction of motion.

As opposed to “pancake style” or axial flux electric motor, the longitudinal length or “width” of the outer walls **406** and **408** are greater than the radial or lateral depth (or length) of the side walls **402** and **404** as illustrated in FIGS. 7A-7C. This geometric proportion results in greater torque generation along the interface of the outer wall **406** and coil assembly **502**. In certain alternate embodiments, the thickness of the magnets comprising the outer wall **406** may also be increased to increase the generation of torque. In any event, the contribution to torque from the outer wall **406** and the inner wall **408** may be greater than the contribution from the side walls **402** and **404** due to the geometry of the cross-section of the radial segment **420** and the varying radius of the components.

Although the core, coil assembly, and magnetic radial segments are illustrated in cross-section as rectangular, any cross-sectional shape may be used depending on the design and performance requirements for a particular motor or generator. In a preferred embodiment, there is more magnetic material positioned in or along an outer wall (such as the magnetic wall **406**) along the longitudinal direction than magnetic material positioned in or along a radial wall (such as the axial or side walls **402** or **408**). For instance, if the magnets forming the magnetic walls are all the same thickness, the length of the outer wall in the longitudinal direction is greater than the length of the axial or side walls in the radial direction. In alternative embodiments, the length of the magnets forming the outer magnetic wall may be the same or shorter than the length of the magnets forming the axial or side walls.

The unique configurations illustrated in FIGS. 7A-7C also leads to several unique properties. For instance, an individual coil **526** and core portion **504** will tend to move out of the tunnel **440** on its own accord (e.g. with no power applied). The natural tendency of this configuration is for the coil **526** to follow the flux lines to the nearest exit **412** or **414**. Conversely if a current is applied the coil **526**, the coil **526** will move through the entirety of the magnetic tunnel depending on polarity of the power applied. The encapsulation of the coil **526** in the magnetic flux of the magnetic tunnel **440** also allows all magnetic fields to be used to generate motor or electric power. Cogging effects can be reduced as the coil will tend to travel out of the tunnel when no current applied. This also means that the coil **526** does not have to be pulsed with an opposing magnetic field at any point while in the magnetic tunnel **440**. Additionally, the coil **526** will travel through the entire magnetic tunnel **440** length with a single DC pulse of the correct polarity. Non-sinusoidal torque or voltage is generated throughout the duration of time that the coil **526** is under the influence of the magnetic tunnel **440** and alternating polarities are not required for this effect to occur.

As illustrated in FIG. 7D, the illustrative embodiment of the toroidal magnetic cylinder **430** comprises eight radial segments where four radial segments **421** are interspersed between the four radial segments **420**. The four radial segments **421** are identical to the radial segments **420** except that the magnetic pole orientation of the magnets has been reversed. So, in the radial segment **420**, all of the interior facing magnetic poles are north forming a NNNN magnetic tunnel configuration as illustrated in FIG. 7A. In contrast, in the radial segment **421**, all of the interior facing magnetic poles are south forming a SSSS magnetic tunnel configuration. Thus, the tunnels radial segments **420** generate flux fields which are of an opposite polarity to the flux fields generated by the radial segments **421**. In traditional motor terminology, each radial segment is a motor magnet pole. Thus, each radial segment is a three dimensional magnetic pole which can create a three dimensional symmetric magnetic field. Alternating the segments then produces a sinusoidal field.

With regard to the toroidal magnetic cylinder **430**, each magnetic or radial segment (e.g. radial segments **420** or **421**) has their respective magnetic configuration (NNNN or SSSS) of like magnetic polarities reversed for each adjacent radial segment. Although, an eight segment toroidal magnetic cylinder **430** is illustrated in FIG. 7D, in other embodiments, two, four, six, ten, etc. segments may be used. The number of segments selected for any given application may be based on engineering design parameters and the particular performance characteristics for an individual application. The scope of this invention specifically includes and contemplates multiple segments having an opposite polarity to the adjacent partial toroidal magnetic cylinders. For simplicity and illustrative purposes, an eight segment toroidal magnetic cylinder is described herein. However, this design choice is in no way meant to limit the choice or number of segments for any multi-segment toroidal magnetic cylinder.

In certain embodiments, the radial segments **420** and **421** may be sized to allow radial gaps **416** to form when the partial toroidal magnetic cylinders are assembled into the complete cylinder **430** as illustrated in FIG. 7D.

As described above, in certain embodiments, the individual magnets forming the toroidal magnetic cylinder **430** couple to various components of the back iron circuit **200**. The back iron circuit **200** may be used to channel part of the magnetic flux path.

#### The Integrity of the Magnetic Tunnel

As described above in reference to FIGS. 6, 7A-7C, by surrounding a coil on all sides with “like” polarity magnets (e.g. all north poles or all south poles), the flux lines from those magnets are forced to travel through the center of the “magnetic tunnel” **404** formed by the surrounding magnets—along the radial or circumferential direction **422** (FIG. 7B) and eventually exit at the mouth or open ends **412** and **414** of the tunnel **440** (see FIG. 7C). The natural tendency of the flux lines is to flow along the shortest path—which is usually in the radial, lateral or “sideways” direction **434** (see FIG. 7B). Although some flux leakage may be acceptable, if the flux leakage is large, the integrity of the magnetic tunnel **440** will be compromised and the flux lines will no longer travel in the circumferential direction. If the flux lines do not travel in the circumferential direction, many of the advantages of certain embodiments will be lost.

As illustrated in FIG. 7A for instance, there are a number of slots or “gaps” between the magnet walls, such as the circumferential slot **410** or slot **411**. These gaps may be carefully controlled or too much flux will leak through the gaps and essentially destroy the magnetic flux integrity of



the magnetic tunnel **440**. In an ideal world, there would be no slots or gaps in the tunnel and thus, it would be impossible for the flux lines to escape laterally. However, if there were no slots, it would be difficult to support the coil assembly and to providing electrical and cooling conduits to the coil assembly.

One method of controlling gap flux leakage is to limit the lateral width of the gaps. For instance, the total length of the sides of the “magnetic tunnel” may be substantially larger than the circular support mechanism slot and the slot reluctance may be high enough to force a circumferential magnetic flux field to form in the magnetic tunnel **440**. As an example, limiting the lateral width of the circumferential slots to roughly a ratio of 1 unit of slot width to every 12 units of circumference/perimeter length may provide enough transverse flux lines to steer the majority of the flux lines along the circumferential direction **422** as discussed above.

Another solution is placing another group or group of magnets in close proximity with the slots such they generate an addition flux field lines across the gap or slot. For instance, two groups of magnets positioned on either side of coil assembly may produce enough “cross flux” to keep the flux in the magnetic tunnel from escaping. A magnet on one side of the slot may have its north pole facing the slot. An opposing magnet on the other side of the slot may have is south pole facing the slot. Thus, cross flux lines from the north pole to the south pole would be generated across the slot.

In one embodiment, permanent magnets orientated to provide a cross flux may be embedded in a coil assembly supporting structure or embedded in the back iron material. In other embodiments, powdered magnetic material may be used. In yet other embodiments, strongly diamagnetic materials (Pyrolytic carbon and superconductor magnets have been shown to be capable of rejecting force lines, and thus could be used.

#### Defining the Flux Path with the Back Iron Circuit

FIG. **8** is an isometric view illustrating the coil assembly **500** positioned within the toroidal magnetic cylinder **430** which is coupled to and surrounded by the back iron circuit **200**. The first flat side wall **210** has been repositioned in an exploded view for clarity. As described above, in the illustrative embodiment, the back iron circuit **200** may include a first side or axial wall **210** and the second side or axial wall **220**. In this embodiment, the first outer cylindrical wall **206** and the second outer cylindrical wall **216** forms and couples to and surrounds the outer magnetic walls **406a** and **406b** of the toroidal magnetic cylinder **430**, respectively (see FIG. **5**). The first inner cylindrical wall **208** and the second inner cylindrical wall **218** is coupled to and surrounded by the inner wall magnets **408a-408b** of the toroidal magnetic cylinder **430** (see FIG. **5**). Thus, the entire back iron circuit **200** includes the inner cylindrical walls **208** and **218**, the outer cylindrical walls **206** and **216**, and the side or axial walls **210** and **220** as illustrated in FIG. **8**. In certain embodiments, the back iron circuit **200** combined with the toroidal magnetic cylinder **430** may form a rotor (or a stator depending on the motor configuration). In certain embodiments, the back iron circuit **200** may be used to channel part of the magnetic flux path. The back iron material channels the magnetic flux produced by the toroidal magnetic cylinder **430** through the back iron material (as opposed to air) to reduce the reluctance of the magnetic circuit. In certain embodiments, therefore, the amount or thickness of the magnets forming the toroidal magnetic cylinder (if perma-

nent magnets are used) may be reduced when using the appropriately designed back iron circuit.

#### Applying Mechanical Torque or Current

In “motor” mode, current is induced in the coils **526**, which will cause electromotive forces to move the coil assembly **500** relative to the toroidal magnetic cylinder **430** or vice versa. In “generator” mode, on the other hand, the movement of the coil assembly **500** relative to the toroidal magnetic cylinder **430** will cause current to be generated in the individual coils **526** to produce a DC current as the individual coils move through each tunnel or radial segment **420** or **421**.

In order to maintain the generated torque and/or power the individual coils **526** in the coil assembly **500** may be selectively energized or activated by way of a switching or controller (not shown). The individual coils **526** in the coil assembly **500** may be electrically, physically, and communicatively coupled to switching or controller which selectively and operatively provides electrical current to the individual coils in a conventional manner.

For instance, the controller may cause current to flow within an individual coil **526** when the individual coil is within a magnetic tunnel segment **420** with a NNNN magnetic pole configuration as illustrated in FIG. **7D**. On the other hand, when the same individual coil rotates into an adjacent magnetic tunnel segment **421** with a SSSS magnetic pole configuration, the controller causes the current within the individual coil **526** to flow in a direction opposite to that when the coil was in the NNNN magnetic pole segment **420** so that the generated magnetic force is in the same direction as coil rotates from one adjacent magnetic segment to the other.

As discussed above, the individual coils **526** may use toroidal winding without end windings and in some embodiments, the individual coils may be connected to each other in series. In other embodiments, a multi-phasic winding arrangement such as six phase, three phase, etc. winding connection may be used where the proper coils **526** are connected together to form a branch of each phase. For instance, two adjacent coils may be phase A coils, the next two adjacent coils may be phase B coils, and the next two adjacent coils may be phase C coils. This three phase configuration would then repeat for all individual coils **526** within the coil assembly **500**. In one embodiment, there are eight (8) pairs of adjacent phase A coils for a total of 16 phase A coils. Similarly, there are eight (8) pairs of adjacent phase B coils for a total of 16 phase B coils, and there are eight (8) pairs of adjacent phase C coils for a total of 16 phase C coils. Thus, in such an embodiment, there are 48 individual coils.

When the coils are energized, the multi-phasic winding can produce a rotating magnetomotive force in the air gap around the coil assembly **500**. The rotating magnetomotive force interacts with the magnetic field generated by the toroidal magnetic tunnel **430**, which in turn produces torque on all sides of the coil assembly **500** and relative movement between the coil assembly and the toroidal magnetic tunnel.

In such embodiments, the individual coils **526** may be connected to a brushless motor controller (not shown) to be activated by a controller or in a similar manner known in the art. For each phase, the motor controller can apply forward current, reverse current, or no current. In operation, the motor controller applies current to the phases in a sequence that continuously imparts torque to turn the magnetic toroidal tunnel in a desired direction (relative to the coil assembly) in motor mode. In certain embodiments, the motor controller can decode the rotor position from signals from



position sensors or can infer the rotor position based on back-emf produced by each phase. In certain embodiments, two controllers may be used. In other embodiments, a single controller may be used. The controller(s) controls the application of current of the proper polarity for the proper amount of time at the right time and controls the voltage/current for speed control. Regardless, the controllers allow for a switching action and a varying voltage action.

In other embodiments, a brushed motor/generator may be used. In such embodiments, one or more commutators (not shown) may be used and positioned, for instance, within the rotor hub 300 (see FIG. 1). In certain embodiments, the number of brushes used may equal the number of toroidal magnetic segments used in the design of the particular motor/generator. For instance, if eight toroidal magnetic segments are used, then eight brushes may be used. The individual coils 526 in the coil assembly 500 may be connected in series having toroidal wound windings. In a brushed design in motor mode, a simplified reverse switching circuit is all that is necessary to switch the current direction as the coils enter and exit the respective toroidal magnetic segment.

#### A Motor/Generator Embodiment

FIG. 9A is an exploded view of one configuration of a system 900 using the back iron circuit 200 and the toroidal magnetic cylinder 430 as a rotor and the coil assembly 500 as a stator. FIG. 9B is an isometric view of the assembled system 900 of FIG. 9B. In FIGS. 9A and 9B, the back iron circuit 200 surrounds the toroidal magnetic cylinder 430 and the coil assembly 500 to form the magnetic disc assembly 400 (the toroidal magnetic cylinder 430 is not visible in FIGS. 9A and 9B). In certain embodiments, the system 900 includes a stator side end plate 902 and an extension or support ring 904 which fixedly couples the coil assembly 500 to the stator side end plate 902 (see FIG. 10).

An end of a rotor shaft 906 extends through the stator side end plate 902. The rotor hub 300 couples to a rotor shaft 906 and supports the back iron circuit 200, which in turn supports the toroidal magnetic cylinder 430 (not visible in FIGS. 9A and 9B). The opposing end of the rotor shaft 906 is supported by the rotor side end plate 908. When assembled, in one embodiment, a pair of side plates 910 and 912 couple the stator side end plate 902 to the rotor side end plate 908 as illustrated in FIG. 9B. As is known in the art, the rotor shaft 906 is a mechanical load transferring device that either inputs a mechanical rotation force into the system when in generator mode or produces a mechanical rotational force when the system is in motor mode.

FIG. 10 is another exploded illustration of the system 900 where the stator or coil assembly 500 is coupled to and supported by the stator end plate 902 via the extension ring 904. Thus, the end plates 902 and 908, the extension ring 904, and the coil assembly 500 (the stator) are stationary in this configuration. In contrast, the rotor hub 300 is fixedly coupled to the back iron circuit 200 which supports and positions the toroidal magnetic cylinder 430. The rotor shaft 906 is structurally supported by the stator end plate 902 and the rotor end plate 908. Bearing units 912 and 914 are positioned between the rotor shaft ends and the end plates to allow the rotor shaft to rotate with respect to the end plates. Thus, as illustrated in FIG. 10, the coil assembly 500 (or stator) and toroidal magnetic disc 430 and the back iron circuit 200 (or rotor) each have their own individual end plates 902 and 908, respectively—which will secure the entire arrangement of the machine and will ensure the integrity of the rotating components.

In certain embodiments, wires and cooling medium may enter the coil assembly 500 from the dedicated end plate 902 via the extension ring 904. In contrast, the rotating components (the toroidal magnetic disc 430 and the back iron circuit 200) may be coupled together and will be coupled in tandem with the rotor hub 300, which in turn is fixedly coupled to the shaft 906.

FIG. 11 is a partial exploded view illustrating certain details regarding the rotor hub 300. Besides the rotor shaft 906, the rotor hub 300 includes a plurality of support shoulders positioned longitudinally along the length of the shaft. A first bearing support shoulder 920 engages and supports the bearing unit 912. A first centering shoulder 922 couples to and supports the first side wall 210 of the back iron circuit 200 (not completely shown). A center shoulder 924 engages with and supports the inner cylindrical walls 208 and 218 of the back iron circuit 200 (see also FIG. 8). A second centering shoulder 926 supports the side wall 220 of the back iron circuit 200. A second bearing support shoulder 928 is designed to engage with and support the second bearing unit 914. In certain embodiments, a keyway 930 may be defined in either end (or both ends) of the rotor shaft 906.

In the embodiment illustrated in FIGS. 9A-11, the coil assembly 500 is the stator. In other configurations, the coil assembly 500 may be a rotor. Furthermore, the embodiments as illustrated is only one way of configuring and supporting the coil assembly 500. In other embodiments the coil assembly 500 may be supported by support ring extending through a center slot between the outer cylindrical walls 206 and 216 from the coil assembly to an exterior casing or housing. In yet other embodiments when the coil assembly 500 is functioning as a rotor, the coil assembly may be supported by a support ring extending through a center slot between the inner cylindrical walls 208 and 218 from the coil assembly to the a shaft. The exact configuration depends on design choices as to whether the coil assembly is to be the stator or the rotor.

#### Advantages of Certain Embodiments

In sum, certain disclosed embodiments have several advantages when compared to traditional motors and generators. Surrounding the coils with magnets as described above creates more flux density and the forces are now all in the direction of motion which may create more torque, minimize vibration, and minimize noise—as compared to conventional motors where forces may try to pull the coil downwards or push it upwards (depending on the polarity), not in the direction of motion. As discussed above, most of the magnetic fields generated are in the direction of motion so there is little, if any, wasted field structure. Continuous torque and continuous power, therefore, are greatly increased. Furthermore, continuous torque density, continuous power density by volume, and continuous power density by weight are also increased when compared to conventional electric motors.

In certain embodiments, the equivalent full torque is available at start with no locked rotor current losses. The permanent magnet configuration has reduced inrush current at start.

In certain embodiments, the coil assembly may be compact and yet the coils are easily cooled because they are surrounded by an effective heat sink. Because there is no reason to overlap the coil windings, there is little, if any unwanted field induction—which also contributes to a more efficient design. One of the advantages of this configuration over conventional motors is that the end turns (in this case the radial section of the coils) are part of the “active section”



of the invention. In conventional motors, the axial length of the copper conductor is the section that produces power. The end turns are a penalty, adding weight and losses, but not producing power because the end region fields are not effectively linking the end windings. However, in the above disclosed embodiments, the entire coil winding is effectively used to produce torque due to the side wall or axial magnets which are axially magnetized—efficiently utilizing the copper windings.

In the “DC” configuration, the motor may run independent of power line frequency or manufactured frequencies reducing the need for expensive pulse width modulated drive controllers or similar controllers.

The foregoing description of the embodiments of the invention has been presented for the purposes of illustration and description. It is not intended to be exhaustive or to limit the invention to the precise form disclosed. Many combinations, modifications and variations are possible in light of the above teaching. For instance, in certain embodiments, each of the above described components and features may be individually or sequentially combined with other wall portion, components or features and still be within the scope of the present invention, for instance:

In one embodiment, there may be a method of producing mechanical rotation, the method including: forming an area of magnetic concentration within a first interior cavity defined in section by an outer magnetic cylinder wall portion having a first longitudinal length, an inner magnetic cylinder wall portion, a first magnetic side wall portion having a first radial length, and a second magnetic side wall portion having a second radial length, each wall portion having their like magnetic poles facing the first interior cavity and the outer magnetic cylinder wall portion including more magnetic material than the first magnetic side wall portion or the second magnetic side wall portion, forming a second area of magnetic concentration within a second interior cavity defined in section by an second outer magnetic cylinder wall portion having a first longitudinal length, a second inner magnetic cylinder wall portion, a third magnetic side wall portion having a first radial length, and a fourth magnetic side wall portion having a second radial length, each wall portion having their like magnetic poles facing away from the second interior cavity and the second outer magnetic cylinder wall portion including more magnetic material than the third magnetic side wall portion or the fourth magnetic side wall portion, positioning a coil within the first interior cavity, applying a current in a first direction to the coil to cause the coil to move to the second interior cavity, applying a current in a second direction to the coil when the coil is within the second interior cavity to move the coil out of the second interior cavity, and coupling a longitudinal shaft to the coil such that as the coil rotates from the first interior cavity to the second interior cavity, the longitudinal shaft rotates.

In another embodiment, there may be a method of producing mechanical rotation, the method including: forming an area of magnetic concentration within a first interior cavity defined in section by an outer magnetic cylinder wall portion having a first longitudinal length, an inner magnetic cylinder wall portion, a first magnetic side wall portion having a first radial length, and a second magnetic side wall portion having a second radial length, each wall portion having their like magnetic poles facing the first interior cavity and the outer magnetic cylinder wall portion including more magnetic material than the first magnetic side wall portion or the second magnetic side wall portion, forming a second area of magnetic concentration within a second

interior cavity defined in section by an second outer magnetic cylinder wall portion having a first longitudinal length, a second inner magnetic cylinder wall portion, a third magnetic side wall portion having a first radial length, and a fourth magnetic side wall portion having a second radial length, each wall portion having their like magnetic poles facing away from the second interior cavity and the second outer magnetic cylinder wall portion including more magnetic material than the third magnetic side wall portion or the fourth magnetic side wall portion, positioning the first interior cavity about a first coil, applying a current in a first direction to the first coil to cause the first interior cavity to move relative to the first coil, positioning the second interior cavity about the first coil, applying a current in a second direction to the first coil when the first coil is within the second interior cavity to cause the second interior cavity to move relative to the first coil, and coupling a longitudinal shaft to the walls forming the first and second interior cavities such that as the first and second cavities rotate, the longitudinal shaft rotates.

Turning now to FIG. 13, there is presented an isometric view of a one embodiment of an assembly 130 comprising an iron core 132, a rotor hub 134 and shaft 136. The iron core 132 is similar to the core 110 discussed above. The iron core 132 and the rotor hub 134 are fastened to a shaft 136 using conventional fastening methods known in the art. In certain embodiments the rotor hub 134 may be composed of non-ferrous materials for example, to eliminate the production of eddy currents. When assembled with the magnetic cylinder 100, a transverse slot (not shown) in the inner wall 104 of the magnetic cylinder (not shown in FIG. 13) allows the core 132 and a portion of the rotor hub 134 to extend through the inner wall 104 of the magnetic cylinder 100 and into the interior cavity 124 (See FIG. 12B).

In certain embodiments, there may be an outer casing or housing 154 which provides structural support for the magnetic cylinder 100 and the longitudinal shaft 152. In certain embodiments, the housing 154 may be formed from any material, alloy, or compound having the required structural strength. In certain embodiments, non-ferrous materials may be used. In some embodiments, external bearings 156 (FIG. 14) may be used to reduce the friction between the longitudinal shaft 152 and the housing 154 or a similar supporting structure. In certain embodiments, the housing 154 may be coupled to a base 158 to provide for structural support for the housing 154.

As described with respect to FIGS. 12A and 12B, the toroidal magnetic cylinder 100 may comprise a plurality of exterior magnets 106 forming the exterior wall 102, a plurality of interior magnets 108 forming the interior wall 104. Additionally, there may first side wall 170 and an opposing side wall 172 which include a plurality of side exterior magnets 168 (see FIG. 14).

FIG. 15 is an isometric illustration of a portion 230 of a magnetic ring, where each portion 230 comprises a magnet 232, a magnet 234, a magnet 236, a magnet 238, and a magnet 240 (not visible in FIG. 15). Positioning the magnet 232 opposing the magnet 234 so that their like poles face each other and positioning the magnet 236 opposing the magnet 238 so that their like poles face each other. In other words, all of the south poles of the magnets 236 through 238 face inward. Furthermore, a magnet 240 is positioned on the back face of the “tube” formed by the magnets 232 to 238 to create an open box shape or cube as illustrated in FIG. 15. For purposes of this disclosure, such a configuration may be known as a “5x” conceptual magnet cylinder assembly. Such a configuration may increase the flux density approximately



## 21

five times at the selected pole exit area **231**. Collapsing or compressing the box area (e.g., moving the magnets **236** towards magnet **238**) further concentrates the flux density but at the expense of a smaller exit area **231**.

Additionally, undescribed embodiments which have interchanged components are still within the scope of the present invention. It is intended that the scope of the invention be limited not by this detailed description, but rather by the claims or future claims supported by the disclosure.

The abstract of the disclosure is provided for the sole reason of complying with the rules requiring an abstract, which will allow a searcher to quickly ascertain the subject matter of the technical disclosure of any patent issued from this disclosure. It is submitted with the understanding that it will not be used to interpret or limit the scope or meaning of the claims.

Any advantages and benefits described may not apply to all embodiments of the invention. When the word “means” is recited in a claim element, Applicant intends for the claim element to fall under 35 USC 112(f). Often a label of one or more words precedes the word “means”. The word or words preceding the word “means” is a label intended to ease referencing of claims elements and is not intended to convey a structural limitation. Such means-plus-function claims are intended to cover not only the structures described herein for performing the function and their structural equivalents, but also equivalent structures. For example, although a nail and a screw have different structures, they are equivalent structures since they both perform the function of fastening. Claims that do not use the word “means” are not intended to fall under 35 USC 112(f).

The invention claimed is:

**1.** An electric machine comprising:

a shaft positioned around a central longitudinal axis,  
a rotor comprising:

a partial toroidal magnetic cylinder defining a semi-circular tunnel and positioned around the central longitudinal axis, the partial toroidal magnetic cylinder comprising;

a plurality of exterior magnets forming an exterior magnetic cylindrical wall,

a plurality of interior magnets forming an interior magnetic cylinder wall, wherein the plurality of interior magnets defines a transverse slot in the interior magnetic cylinder wall,

a first plurality of side magnets forming a first magnetic side wall, the first magnetic side wall positioned adjacent to the exterior magnetic cylinder wall and the interior magnetic cylinder wall, and

a second plurality of side magnets forming an opposing second magnetic side wall, the second magnetic side wall positioned adjacent to the exterior magnetic cylinder wall and the interior magnetic cylinder wall a predetermined distance from the first magnetic side wall along the central longitudinal axis,

a stator positioned within the partial toroidal magnetic cylinder, the stator comprising:

a circular core positioned concentrically about the central longitudinal axis, and

at least one coil positioned about the circular core; and

a rotor hub configured to support the stator, the rotor hub having an inner edge coupled to the shaft and an outer edge coupled to the stator, wherein the transverse slot allows a portion of the rotor hub to pass through the interior magnetic cylindrical wall and support the sta-

## 22

tor, and wherein the plurality of interior magnets forming the interior magnetic cylinder wall are radially offset from the shaft by a portion of the rotor hub.

**2.** The electric machine of claim **1**, wherein an inner face of each of the plurality of magnets forming the partial toroidal magnetic cylinder have rectangular profiles with a planar surface.

**3.** The electric machine of claim **2**, wherein the inner faces of the partial toroidal magnetic cylinder have abutting planar surfaces.

**4.** The electric machine of claim **1**, wherein a radial distance between the plurality of interior magnets forming the interior magnetic cylinder wall and the shaft defines an interior cavity adjacent to the shaft.

**5.** The electric machine of claim **1**, wherein the longitudinal length of an inner face of the outer magnetic cylinder wall is greater than the radial length of an inner face of the first magnetic side wall.

**6.** The electric machine of claim **1**, wherein each of the plurality of magnets forming the partial toroidal magnetic cylinder have their like poles facing towards an interior cavity of the semi-circular tunnel.

**7.** The electric machine of claim **1**, wherein the at least one coil comprises a plurality of wire windings.

**8.** The electric machine of claim **1**, wherein the partial toroidal magnetic cylinder is adapted to rotate about the shaft of the electric machine and the at least one coil is positioned about the central longitudinal axis within a rotational path of the partial toroidal magnetic cylinder.

**9.** The electric machine of claim **1**, wherein the interior magnetic cylinder wall comprises a first interior magnetic inner segment and a second interior magnetic inner segment, and wherein the transverse slot is defined between the first interior magnetic inner segment and the second interior magnetic segment.

**10.** An electric machine comprising:

a shaft positioned around a central longitudinal axis,  
a rotor comprising:

a partial toroidal magnetic cylinder defining a semi-circular tunnel and positioned around the central longitudinal axis, the partial toroidal magnetic cylinder comprising;

an inner rotor comprising a plurality of flux shaping salient magnetic poles configured to concentrate flux linkage in the partial toroidal magnetic cylinder, the inner rotor having a first inner rotor portion and a second inner rotor portion, wherein the first inner rotor portion and the second inner rotor portion defines a transverse slot in the inner rotor;

a first axial rotor comprising a plurality of flux shaping salient magnetic poles configured to concentrate flux linkage in the partial toroidal magnetic cylinder, the first axial rotor coupled at an inner edge to a first end of the inner rotor;

a second axial rotor comprising a plurality of flux shaping salient magnetic poles configured to concentrate flux linkage in the partial toroidal magnetic cylinder, the second axial rotor couple at an inner edge to a second end of the inner rotor;

an outer rotor comprising a plurality of flux shaping salient magnetic poles configured to concentrate flux linkage in the partial toroidal magnetic cylinder, the outer rotor coupled at a first end to an outer edge of the first rotor core and coupled at a second end to an outer edge of the second axial rotor, such that, the rotors form a four-side magnetic torque tunnel,



23

a stator assembly positioned within the partial toroidal magnetic cylinder, the stator assembly comprising:  
 a circular core positioned concentrically about the central longitudinal axis, and

a plurality of coils wound around the circular core; and  
 a rotor hub configured to support the stator assembly, the rotor hub having an inner edge coupled to the shaft and an outer edge coupled to the stator, wherein the transverse slot allows a portion of the rotor hub to pass between the first inner rotor portion and the second rotor portion and support the stator, and wherein a radial distance between the inner rotor and the shaft defines an interior cavity adjacent to the shaft.

11. The electric machine of claim 10, wherein the plurality of flux shaping salient magnetic poles comprising the inner rotor are radially offset from the shaft by a portion of the rotor hub.

12. The electric machine of claim 10, wherein an inner face of each of the plurality of flux shaping salient magnetic poles forming the partial toroidal magnetic cylinder have rectangular profiles.

13. The electric machine of claim 10, wherein an inner face of each of plurality of flux shaping salient magnetic poles forming the partial toroidal magnetic cylinder have a planar surface.

24

14. The electric machine of claim 13, wherein the inner faces of the partial toroidal magnetic cylinder have abutting planar surfaces.

15. The electric machine of claim 10, wherein the plurality of flux shaping salient magnet poles forming the partial toroidal magnetic cylinder are offset from the shaft by the portion of the rotor hub configured to function as a lever.

16. The electric machine of claim 10 wherein the longitudinal length of an inner face of the plurality of flux shaping salient magnetic poles of the outer rotor is greater than the radial length of an inner face of the plurality of flux shaping salient magnetic poles of the first axial rotor.

17. The electric machine of claim 10, wherein each of the plurality of flux shaping salient magnetic poles configured to concentrate flux linkage in the partial toroidal magnetic cylinder have their like poles facing towards an interior cavity of the semi-circular tunnel.

18. The electric machine of claim 10, wherein the partial toroidal magnetic cylinder is adapted to rotate about the shaft of the electric machine and the plurality of coils wound around the circular core are positioned about the central longitudinal axis within a rotational path of the partial toroidal magnetic cylinder.

\* \* \* \* \*