



US011283471B2

(12) **United States Patent**
Park et al.

(10) **Patent No.:** **US 11,283,471 B2**
(45) **Date of Patent:** ***Mar. 22, 2022**

(54) **BIT INTERLEAVER FOR LOW-DENSITY PARITY CHECK CODEWORD HAVING LENGTH OF 64800 AND CODE RATE OF 2/15 AND 1024-SYMBOL MAPPING, AND BIT INTERLEAVING METHOD USING SAME**

(71) Applicant: **ELECTRONICS AND TELECOMMUNICATIONS RESEARCH INSTITUTE**, Daejeon (KR)

(72) Inventors: **Sung-Ik Park**, Daejeon (KR); **Sun-Hyoung Kwon**, Daejeon (KR); **Jae-Young Lee**, Daejeon (KR); **Heung-Mook Kim**, Daejeon (KR); **Nam-Ho Hur**, Sejong (KR)

(73) Assignee: **ELECTRONICS AND TELECOMMUNICATIONS RESEARCH INSTITUTE**, Daejeon (KR)

(*) Notice: Subject to any disclaimer, the term of this patent is extended or adjusted under 35 U.S.C. 154(b) by 0 days.

This patent is subject to a terminal disclaimer.

(21) Appl. No.: **16/864,957**

(22) Filed: **May 1, 2020**

(65) **Prior Publication Data**

US 2020/0259509 A1 Aug. 13, 2020

Related U.S. Application Data

(63) Continuation of application No. 16/369,742, filed on Mar. 29, 2019, now Pat. No. 10,680,654, which is a (Continued)

(30) **Foreign Application Priority Data**

Feb. 16, 2015 (KR) 10-2015-0023411

(51) **Int. Cl.**
H03M 13/00 (2006.01)
H03M 13/27 (2006.01)

(Continued)

(52) **U.S. Cl.**
CPC *H03M 13/2792* (2013.01); *G06F 11/1004* (2013.01); *H03M 13/1102* (2013.01); (Continued)

(58) **Field of Classification Search**
CPC *H03M 13/2792*; *H03M 13/1165*; *H03M 13/2778*; *H03M 13/27*; *H03M 13/255*; (Continued)

(56) **References Cited**

U.S. PATENT DOCUMENTS

8,179,955 B2 5/2012 Taylor et al.
10,411,739 B2 9/2019 Jeong et al.
(Continued)

FOREIGN PATENT DOCUMENTS

KR 20150005426 A 1/2015

OTHER PUBLICATIONS

Digital Video Broadcasting (DVB); Frame structure channel coding and modulation for a second generation digital terrestrial television broadcasting system (DVB-T2), Final Draft ETSI EN 302 755 V1.2.1 (Oct. 2010), European Standard (telecommunications series).

Primary Examiner — Albert Decady

Assistant Examiner — Osman M Alshack

(57) **ABSTRACT**

A bit-interleaved coded modulation (BICM) reception device and a BICM reception method are disclosed herein. The BICM reception device includes a demodulator, a bit deinterleaver, and a decoder. The demodulator performs demodulation corresponding to 1024-symbol mapping. The bit deinterleaver performs group-unit deinterleaving on interleaved values. The interleaved values are generated after the demodulation. The decoder restores information

(Continued)

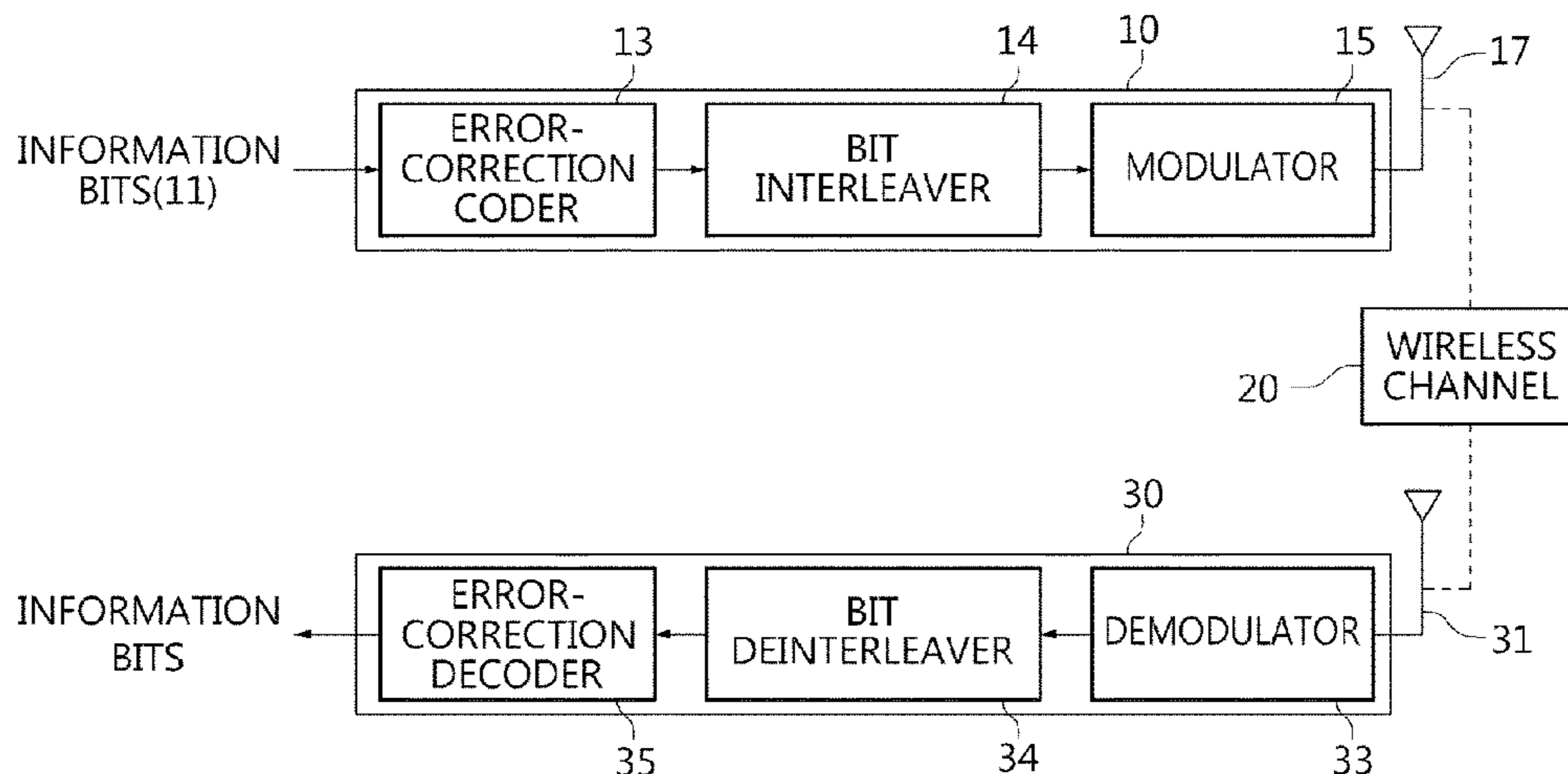

bits by LDPC-decoding deinterleaved values generated based on the group-unit deinterleaving. The deinterleaved values corresponds to a LDPC codeword having a length of 64800 and a code rate of 2/15.

5 Claims, 6 Drawing Sheets

Related U.S. Application Data

continuation of application No. 14/664,707, filed on Mar. 20, 2015, now Pat. No. 10,298,268.

- (51) **Int. Cl.**
H03M 13/11 (2006.01)
H03M 13/25 (2006.01)
G06F 11/10 (2006.01)
G11B 20/18 (2006.01)
- (52) **U.S. Cl.**
 CPC *H03M 13/1165* (2013.01); *H03M 13/255* (2013.01); *H03M 13/27* (2013.01); *H03M 13/2778* (2013.01); *G06F 11/1076* (2013.01); *G11B 20/1806* (2013.01); *G11B 20/1809* (2013.01); *G11B 2020/185* (2013.01)
- (58) **Field of Classification Search**
 CPC H03M 13/1102; H03M 13/2703; G06F 11/1004; G06F 11/1076; G11B 2020/185; G11B 20/1809; G11B 20/1806
 USPC 714/752, 776, 800–805
 See application file for complete search history.

(56) **References Cited**

U.S. PATENT DOCUMENTS

- 2002/0057750 A1 5/2002 Nakao et al.
- 2004/0086059 A1 5/2004 Eroz et al.

- 2008/0104474 A1 5/2008 Gao et al.
- 2008/0163025 A1 7/2008 Djordjevic et al.
- 2010/0162077 A1 6/2010 Kim et al.
- 2010/0306627 A1 12/2010 Sakai et al.
- 2011/0075710 A1 3/2011 Park et al.
- 2011/0107183 A1 5/2011 Zhang et al.
- 2011/0167317 A1* 7/2011 Kim H03M 13/6325
714/758
- 2011/0202814 A1 8/2011 Zhang et al.
- 2011/0202820 A1 8/2011 Eroz et al.
- 2011/0239075 A1 9/2011 Xu et al.
- 2012/0134446 A1* 5/2012 Zhou H04L 27/3405
375/320
- 2013/0142219 A1 6/2013 Park et al.
- 2014/0101520 A1 4/2014 Eroz et al.
- 2014/0126672 A1 5/2014 Petrov
- 2015/0095744 A1* 4/2015 Jeong H03M 13/1165
714/776
- 2015/0100845 A1* 4/2015 Myung H03M 13/2703
714/752
- 2015/0121176 A1* 4/2015 Myung H03M 13/6555
714/776
- 2015/0128005 A1* 5/2015 Jeong H04L 1/0041
714/752
- 2015/0222471 A1* 8/2015 Myung H04L 27/3411
375/296
- 2015/0236721 A1 8/2015 Kim et al.
- 2015/0236816 A1 8/2015 Myung et al.
- 2015/0270853 A1 9/2015 Jeong et al.
- 2015/0358648 A1* 12/2015 Limberg H03M 13/253
725/109
- 2016/0043740 A1* 2/2016 Ikegaya H03M 13/1165
714/776
- 2016/0204804 A1* 7/2016 Ikegaya H03M 13/271
714/752
- 2016/0218824 A1 7/2016 Kim et al.

* cited by examiner

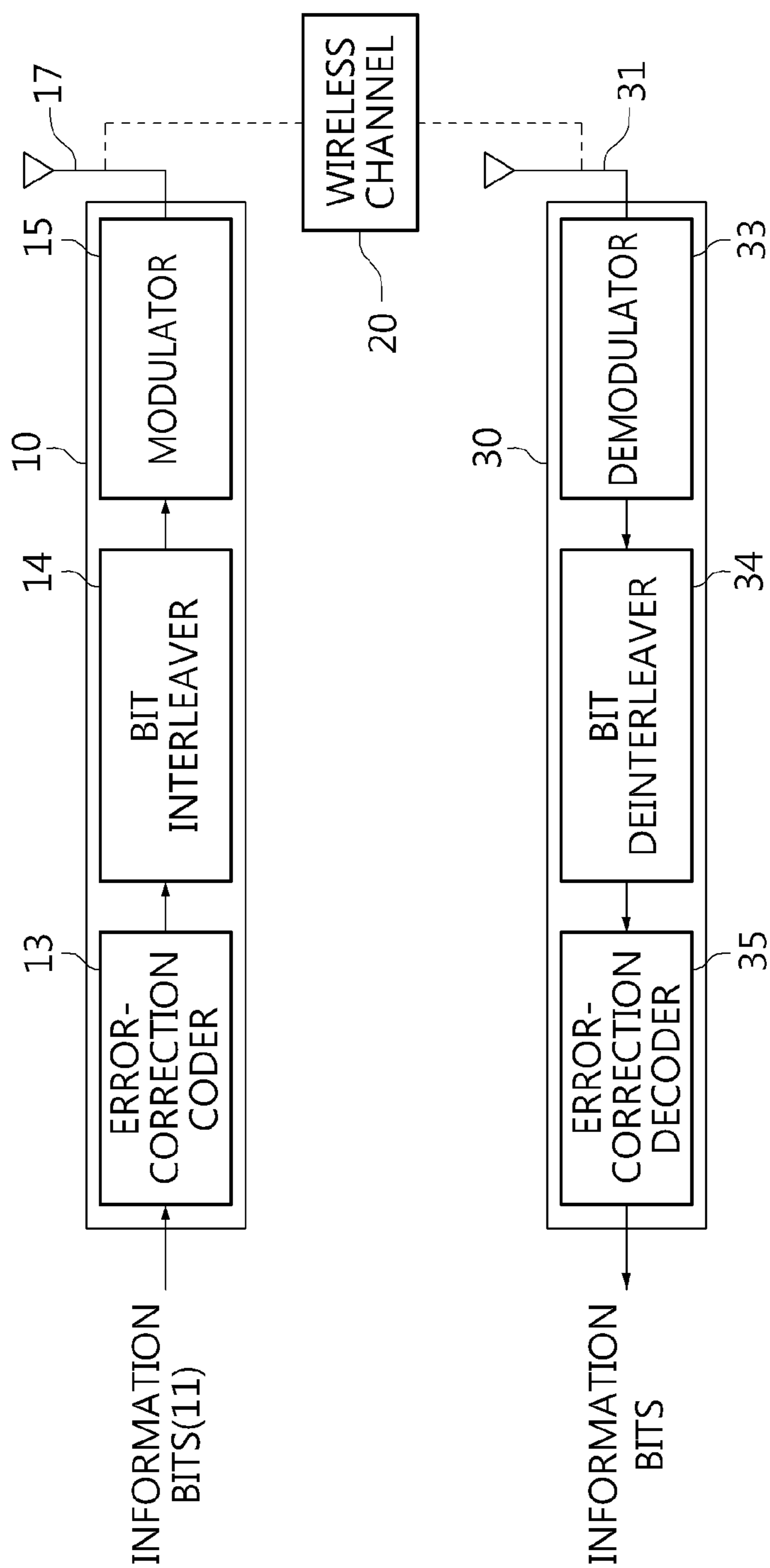

FIG. 1

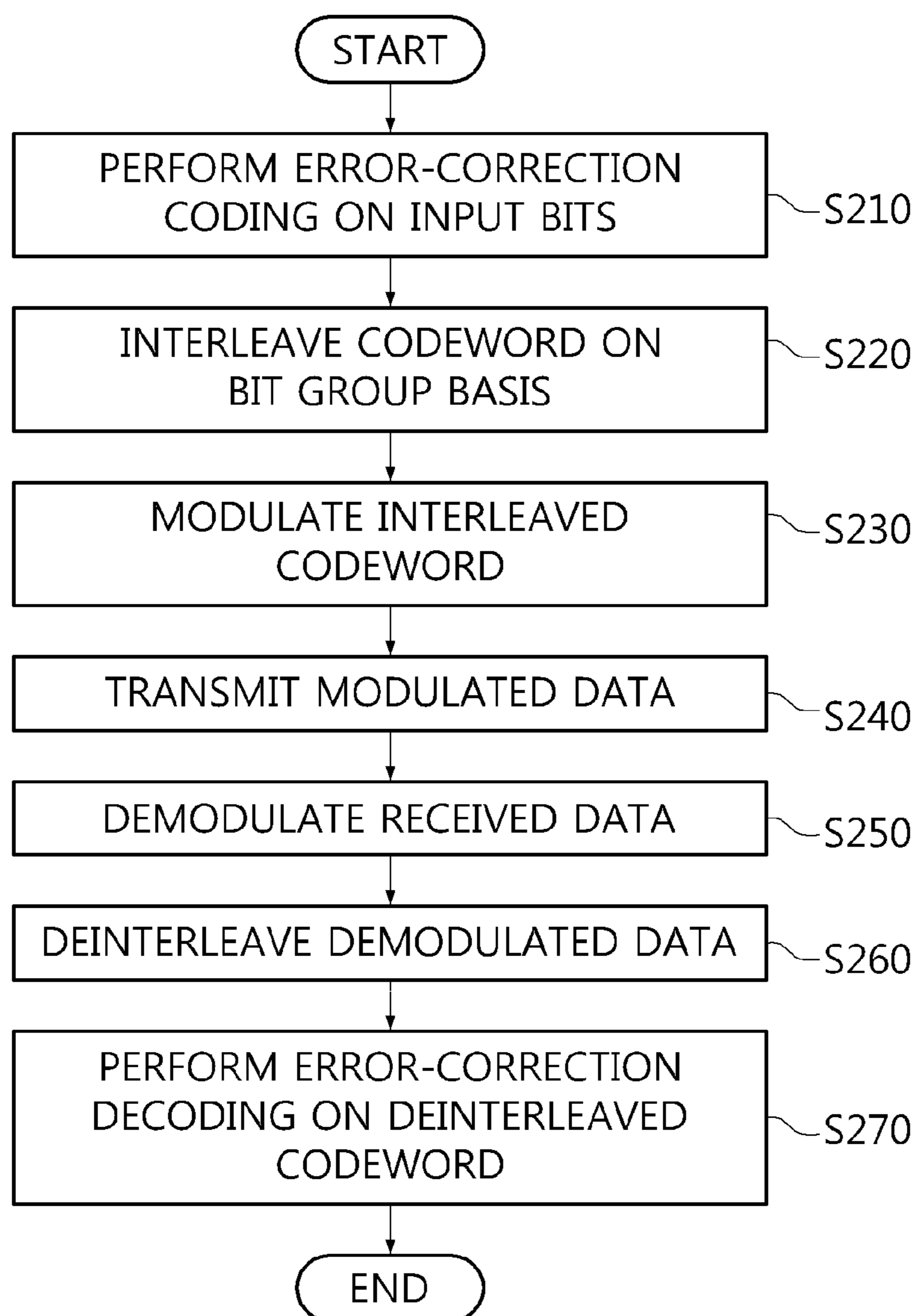

FIG. 2

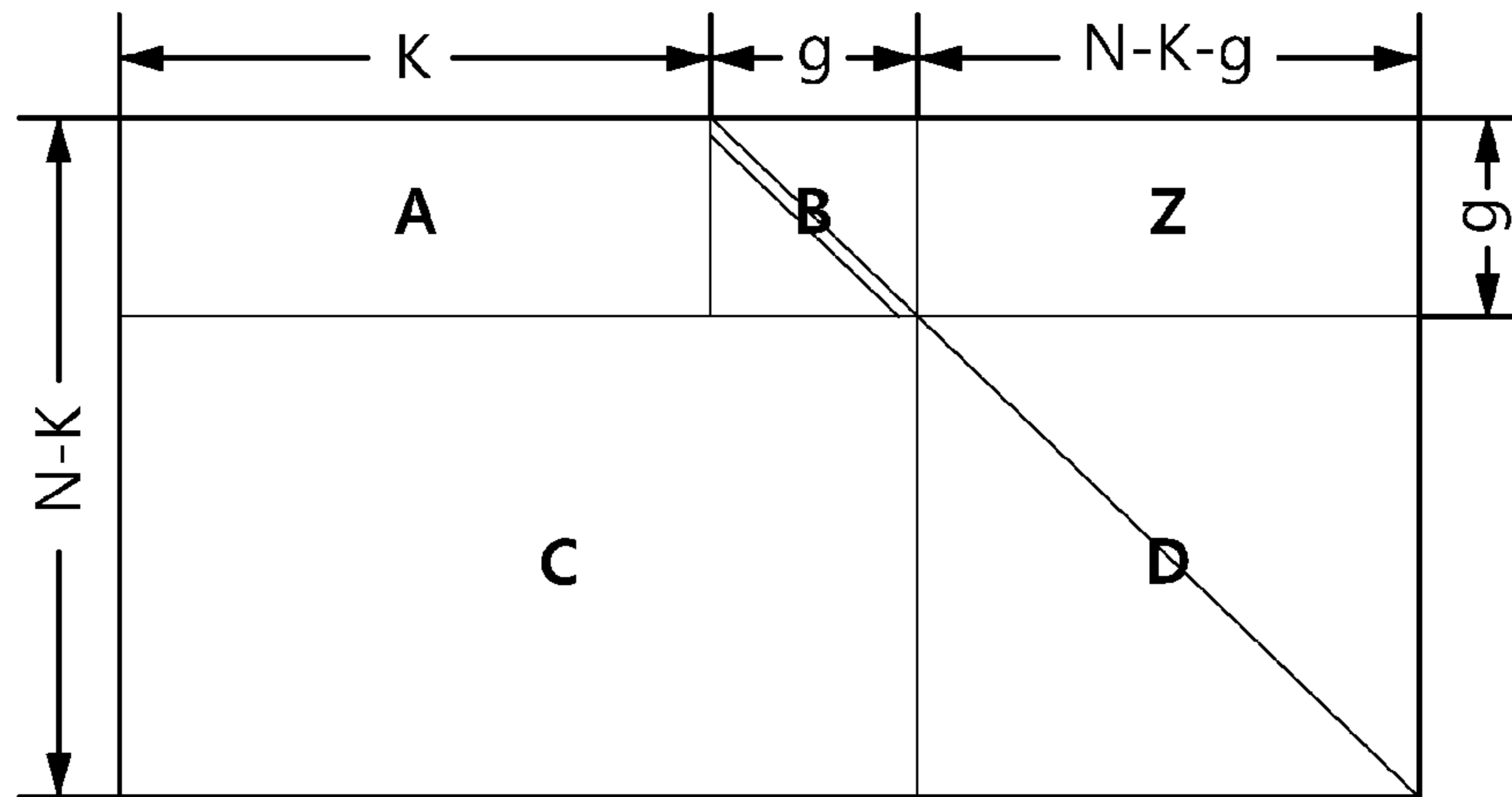

FIG. 3

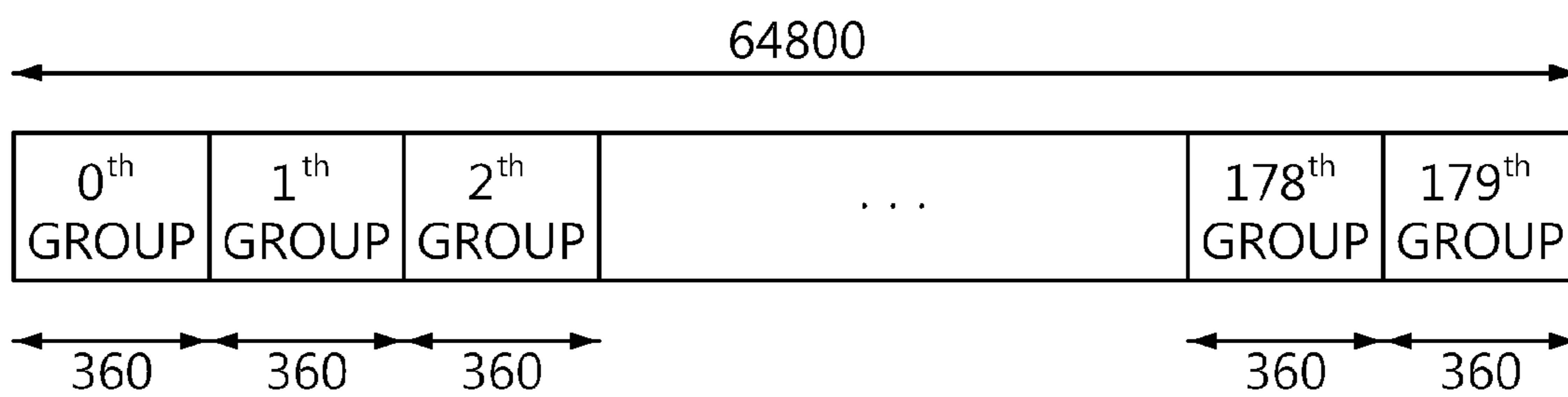

FIG. 4

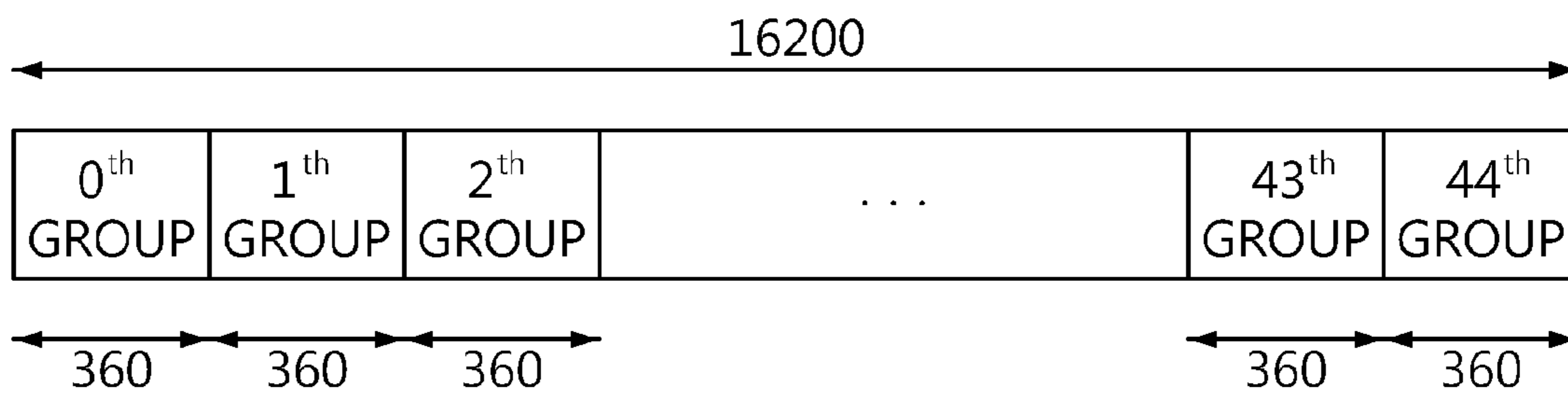

FIG. 5

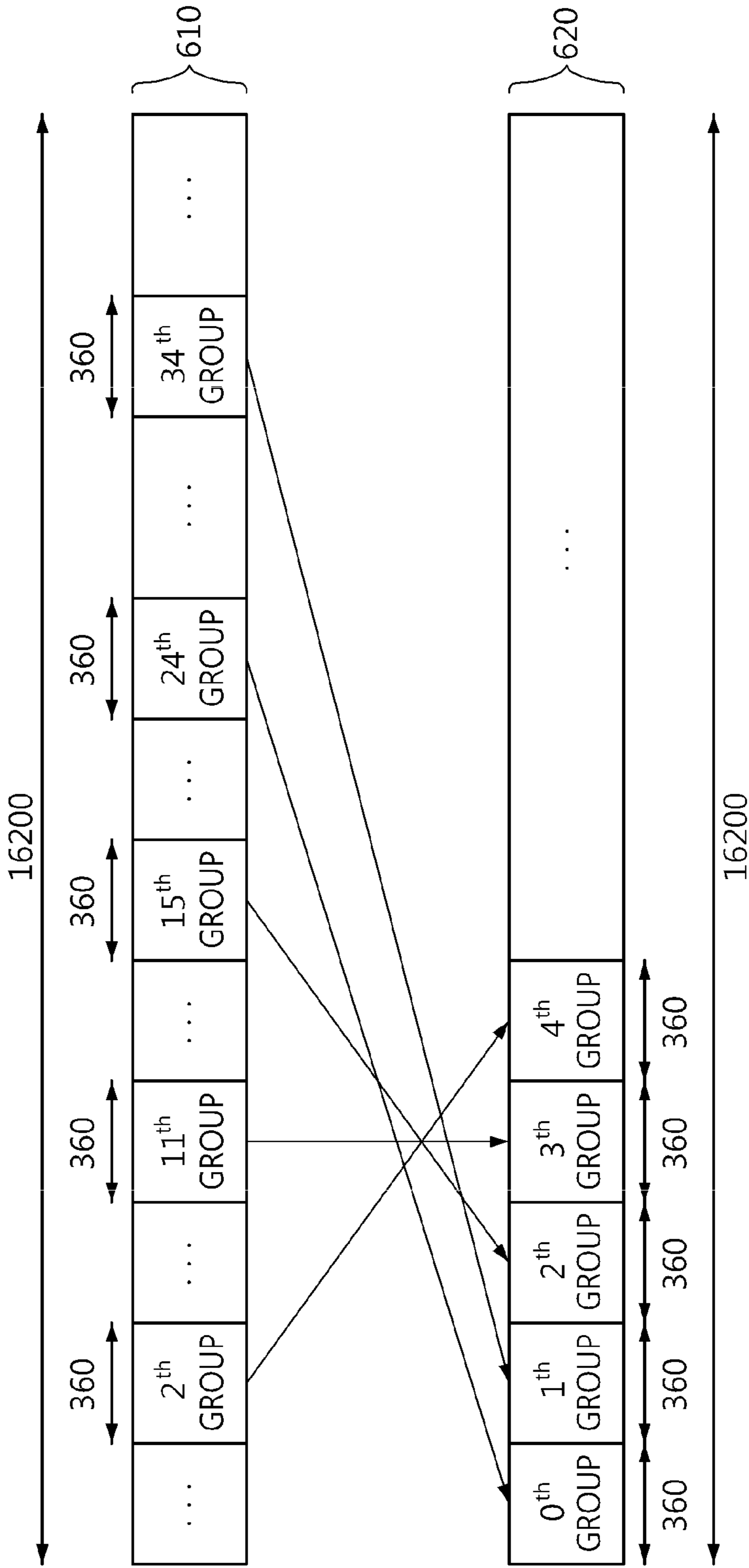

FIG. 6

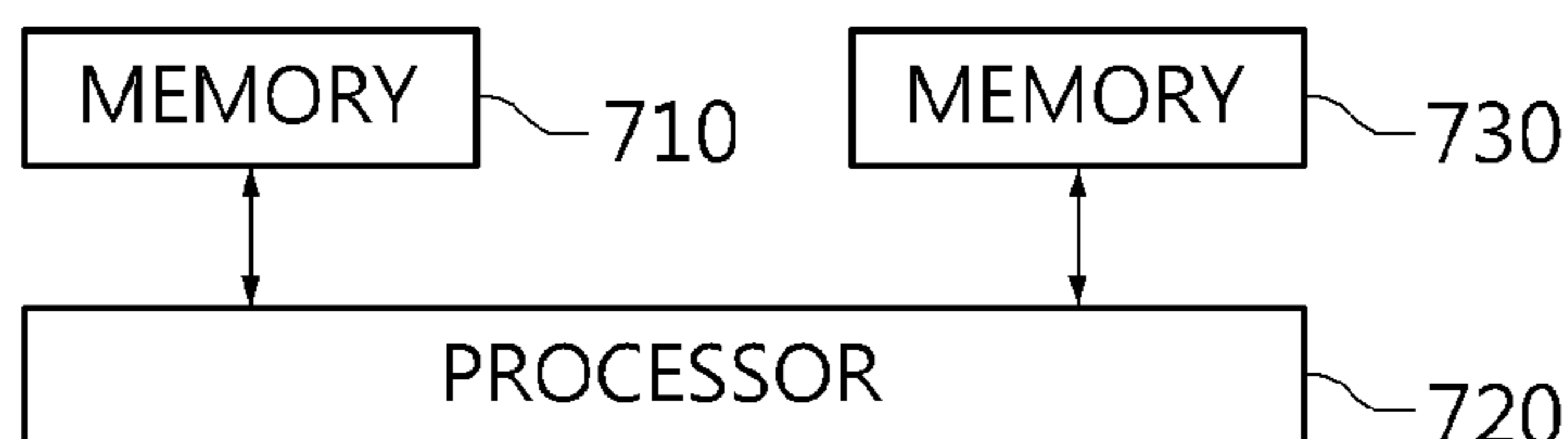

FIG. 7

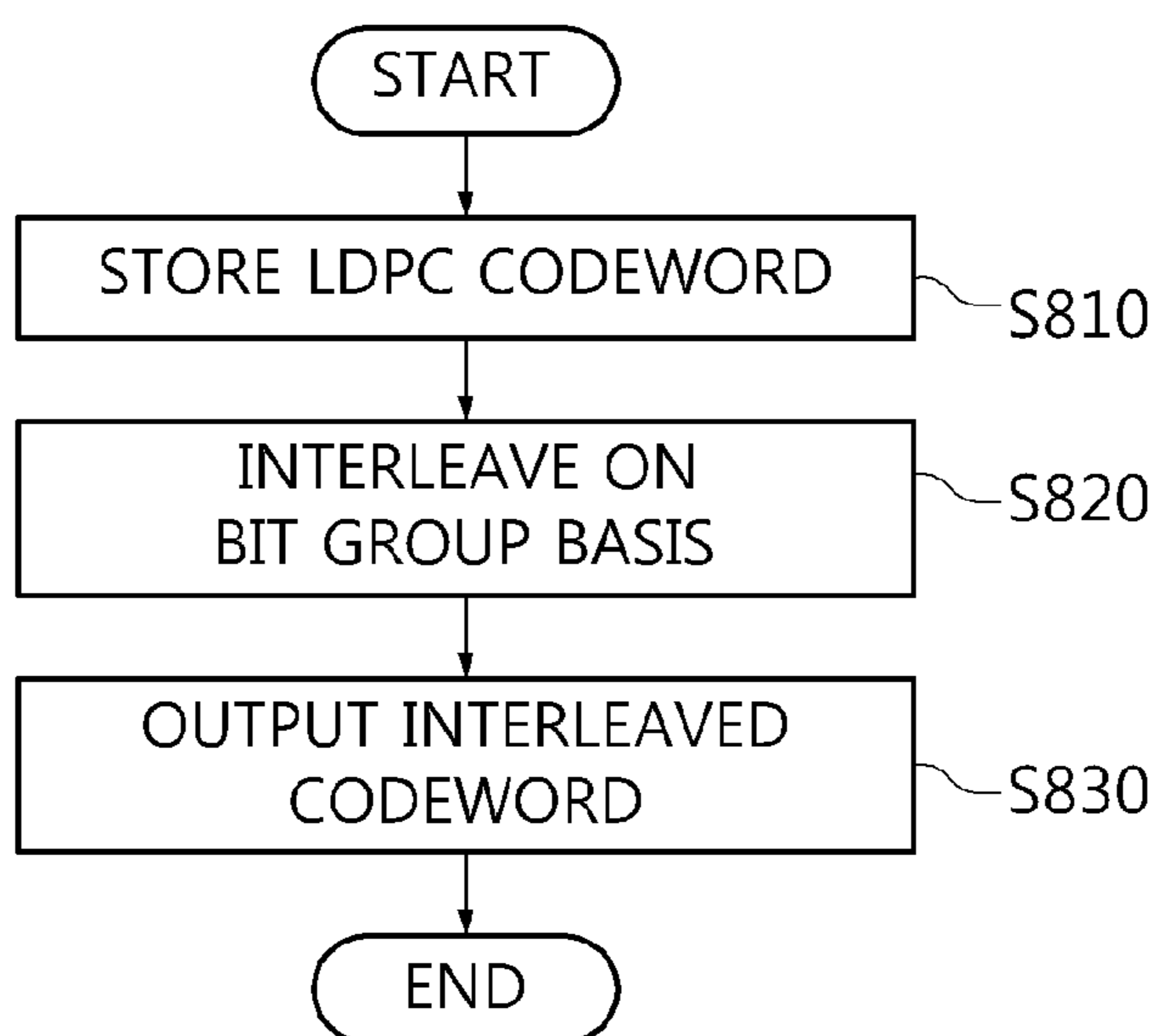

FIG. 8

1

**BIT INTERLEAVER FOR LOW-DENSITY
PARITY CHECK CODEWORD HAVING
LENGTH OF 64800 AND CODE RATE OF 2/15
AND 1024-SYMBOL MAPPING, AND BIT
INTERLEAVING METHOD USING SAME**

CROSS-REFERENCE TO RELATED
APPLICATIONS

This application is a continuation of U.S. application Ser. No. 16/369,742, filed Mar. 29, 2019, which is a continuation of U.S. Pat. No. 10,298,268, issued May 21, 2019, which claims the benefit of Korean Patent Application No. 10-2015-0023411, filed Feb. 16, 2015, which is hereby incorporated by reference herein in its entirety.

BACKGROUND

1. Technical Field

The present disclosure relates generally to an interleaver and, more particularly, to a bit interleaver that is capable of distributing burst errors occurring in a digital broadcast channel.

2. Description of the Related Art

Bit-Interleaved Coded Modulation (BICM) is bandwidth-efficient transmission technology, and is implemented in such a manner that an error-correction coder, a bit-by-bit interleaver and a high-order modulator are combined with one another.

BICM can provide excellent performance using a simple structure because it uses a low-density parity check (LDPC) coder or a Turbo coder as the error-correction coder. Furthermore, BICM can provide high-level flexibility because it can select modulation order and the length and code rate of an error correction code in various forms. Due to these advantages, BICM has been used in broadcasting standards, such as DVB-T2 and DVB-NGH, and has a strong possibility of being used in other next-generation broadcasting systems.

However, in spite of those advantages, BICM suffers from the rapid degradation of performance unless burst errors occurring in a channel are appropriately distributed via the bit-by-bit interleaver. Accordingly, the bit-by-bit interleaver used in BICM should be designed to be optimized for the modulation order or the length and code rate of the error correction code.

SUMMARY

At least one embodiment of the present invention is directed to the provision of an intra-BICM bit interleaver that can effectively distribute burst errors occurring in a broadcasting system channel.

At least one embodiment of the present invention is directed to the provision of a bit interleaver that is optimized for an LDPC coder having a length of 64800 and a code rate of 2/15 and a modulator performing 1024-symbol mapping and, thus, can be applied to next-generation broadcasting systems, such as ATSC 3.0.

In accordance with an aspect of the present invention, there is provided a bit interleaver, including a first memory configured to store a low-density parity check (LDPC) codeword having a length of 64800 and a code rate of 2/15; a processor configured to generate an interleaved codeword

2

by interleaving the LDPC codeword on a bit group basis, the size of the bit group corresponding to a parallel factor of the LDPC codeword; and a second memory configured to provide the interleaved codeword to a modulator for 1024-symbol mapping.

The 1024-symbol mapping may be NUC (Non-Uniform Constellation) symbol mapping corresponding to 1024 constellations (symbols).

The parallel factor may be 360, and each of the bit groups may include 360 bits.

The LDPC codeword may be represented by $(u_0, u_1, \dots, u_{N_{ldpc}-1})$ ($u_0, u_1, \dots, u_{N_{ldpc}-1}$), and may be divided into 180 bit groups each including 360 bits, as in the following equation:

$$X_j = \{u_k | 360 \times j \leq k < 360 \times (j+1), 0 \leq k < N_{ldpc}\} \text{ for } 0 \leq j < N_{group}$$

where X_j is an j -th bit group, N_{ldpc} is 64800, and N_{group} is 180.

The interleaving may be performed using the following equation using permutation order:

$$Y_j = X_{\pi(j)}, 0 \leq j \leq N_{group}$$

where X_j is the j -th bit group, Y_j is an interleaved j -th bit group, and $\pi(j)$ is a permutation order for bit group-based interleaving (bit group-unit interleaving).

The permutation order may correspond to an interleaving sequence represented by the following equation:

```
interleaving sequence={157 25 107 160 37 138 111
35 29 44 15 162 66 20 49 126 89 147 159 174
142 26 146 10 164 152 57 110 83 167 169 16
6 172 62 173 7 145 4 67 115 50 39 72 79 74
40 132 42 30 163 161 55 143 63 117 86 121 2
28 69 150 24 177 43 158 27 21 128 46 118
114 127 135 92 76 19 94 179 3 52 101 137 84
73 108 91 120 47 1 102 58 68 82 59 119 64 31
61 105 103 151 124 70 8 155 90 166 41 45
178 113 140 75 148 109 100 125 11 116 34 36
176 170 156 136 171 122 78 87 106 123 149
17 99 175 18 9 165 153 12 81 77 60 93 104 13
5 88 96 141 133 154 144 48 97 23 14 98 53
134 112 65 0 130 32 168 33 131 22 38 56 80
95 71 85 139 129 51 54}
```

In accordance with another aspect of the present invention, there is provided a bit interleaving method, including storing an LDPC codeword having a length of 64800 and a code rate of 2/15; generating an interleaved codeword by interleaving the LDPC codeword on a bit group basis corresponding to the parallel factor of the LDPC codeword; and outputting the interleaved codeword to a modulator for 1024-symbol mapping.

In accordance with still another aspect of the present invention, there is provided a BICM device, including an error-correction coder configured to output an LDPC codeword having a length of 64800 and a code rate of 2/15; a bit interleaver configured to interleave the LDPC codeword on a bit group basis corresponding to the parallel factor of the LDPC codeword and output the interleaved codeword; and a modulator configured to perform 1024-symbol mapping on the interleaved codeword.

BRIEF DESCRIPTION OF THE DRAWINGS

The above and other objects, features and advantages of the present invention will be more clearly understood from the following detailed description taken in conjunction with the accompanying drawings, in which:

FIG. 1 is a block diagram illustrating a broadcast signal transmission and reception system according to an embodiment of the present invention;

FIG. 2 is an operation flowchart illustrating a broadcast signal transmission and reception method according to an embodiment of the present invention;

FIG. 3 is a diagram illustrating the structure of a parity check matrix (PCM) corresponding to an LDPC code to

FIG. 4 is a diagram illustrating the bit groups of an LDPC codeword having a length of 64800;

FIG. 5 is a diagram illustrating the bit groups of an LDPC codeword having a length of 16200;

FIG. 6 is a diagram illustrating interleaving that is performed on a bit group basis in accordance with an interleaving sequence;

FIG. 7 is a block diagram illustrating a bit interleaver according to an embodiment of the present invention; and

FIG. 8 is an operation flowchart illustrating a bit interleaving method according to an embodiment of the present invention.

DETAILED DESCRIPTION

Embodiments of the present invention will be described in detail below with reference to the accompanying drawings. Repeated descriptions and descriptions of well-known functions and configurations that have been deemed to make the gist of the present invention unnecessarily obscure will be omitted below. The embodiments of the present invention are intended to fully describe the present invention to persons having ordinary knowledge in the art to which the present invention pertains. Accordingly, the shapes, sizes, etc. of components in the drawings may be exaggerated to make the description obvious.

Embodiments of the present invention will be described in detail below with reference to the accompanying drawings.

FIG. 1 is a block diagram illustrating a broadcast signal transmission and reception system according to an embodiment of the present invention.

Referring to FIG. 1, it can be seen that a BICM device 10 and a BICM reception device 30 communicate with each other over a wireless channel 20.

The BICM device 10 generates an n-bit codeword by encoding k information bits 11 using an error-correction coder 13. In this case, the error-correction coder 13 may be an LDPC coder or a Turbo coder.

The codeword is interleaved by a bit interleaver 14, and thus the interleaved codeword is generated.

In this case, the interleaving may be performed on a bit group basis (by a unit of a bit group). In this case, the error-correction coder 13 may be an LDPC coder having a length of 64800 and a code rate of 2/15. A codeword having a length of 64800 may be divided into a total of 180 bit groups. Each of the bit groups may include 360 bits, i.e., the parallel factor of an LDPC codeword.

In this case, the interleaving may be performed on a bit group basis (by a unit of a bit group) in accordance with an interleaving sequence, which will be described later.

In this case, the bit interleaver 14 prevents the performance of error correction code from being degraded by effectively distributing burst errors occurring in a channel. In this case, the bit interleaver 14 may be separately designed in accordance with the length and code rate of the error correction code and the modulation order.

The interleaved codeword is modulated by a modulator 15, and is then transmitted via an antenna 17.

In this case, the modulator 15 may be based on a concept including symbol mapper (symbol mapping device). In this case, the modulator 15 may be a symbol mapping device

performing 1024-symbol mapping which maps codes onto 1024 constellations (symbols).

In this case, the modulator 15 may be a uniform modulator, such as a quadrature amplitude modulation (QAM) modulator, or a non-uniform modulator.

The modulator 15 may be a symbol mapping device performing NUC (Non-Uniform Constellation) symbol mapping which uses 1024 constellations (symbols).

The signal transmitted via the wireless channel 20 is received via the antenna 31 of the BICM reception device 30, and, in the BICM reception device 30, is subjected to a process reverse to the process in the BICM device 10. That is, the received data is demodulated by a demodulator 33, is deinterleaved by a bit deinterleaver 34, and is then decoded by an error correction decoder 35, thereby finally restoring the information bits.

It will be apparent to those skilled in the art that the above-described transmission and reception processes have been described within a minimum range required for a description of the features of the present invention and various processes required for data transmission may be added.

FIG. 2 is an operation flowchart illustrating a broadcast signal transmission and reception method according to an embodiment of the present invention.

Referring to FIG. 2, in the broadcast signal transmission and reception method according to this embodiment of the present invention, input bits (information bits) are subjected to error-correction coding at step S210.

That is, at step S210, an n-bit codeword is generated by encoding k information bits using the error-correction coder.

In this case, step S210 may be performed as in an LDPC encoding method, which will be described later.

Furthermore, in the broadcast signal transmission and reception method, an interleaved codeword is generated by interleaving the n-bit codeword on a bit group basis at step S220.

In this case, the n-bit codeword may be an LDPC codeword having a length of 64800 and a code rate of 2/15. The codeword having a length of 64800 may be divided into a total of 180 bit groups. Each of the bit groups may include 360 bits corresponding to the parallel factors of an LDPC codeword.

In this case, the interleaving may be performed on a bit group basis (by a unit of a bit group) in accordance with an interleaving sequence, which will be described later.

Furthermore, in the broadcast signal transmission and reception method, the encoded data is modulated at step S230.

That is, at step S230, the interleaved codeword is modulated using the modulator.

In this case, the modulator may be based on a concept including symbol mapper (symbol mapping device). In this case, the modulator may be a symbol mapping device performing 1024-symbol mapping which maps codes onto 1024 constellations (symbols).

In this case, the modulator may be a uniform modulator, such as a QAM modulator, or a non-uniform modulator.

The modulator may be a symbol mapping device performing NUC (Non-Uniform Constellation) symbol mapping which uses 1024 constellations (symbols).

Furthermore, in the broadcast signal transmission and reception method, the modulated data is transmitted at step S240.

That is, at step S240, the modulated codeword is transmitted over the wireless channel via the antenna.

5

Furthermore, in the broadcast signal transmission and reception method, the received data is demodulated at step S250.

That is, at step S250, the signal transmitted over the wireless channel is received via the antenna of the receiver, and the received data is demodulated using the demodulator.

Furthermore, in the broadcast signal transmission and reception method, the demodulated data is deinterleaved at step S260. In this case, the deinterleaving of step S260 may be reverse to the operation of step S220.

Furthermore, in the broadcast signal transmission and reception method, the deinterleaved codeword is subjected to error correction decoding at step S270.

That is, at step S270, the information bits are finally restored by performing error correction decoding using the error correction decoder of the receiver.

In this case, step S270 corresponds to a process reverse to that of an LDPC encoding method, which will be described later.

An LDPC code is known as a code very close to the Shannon limit for an additive white Gaussian noise (AWGN) channel, and has the advantages of asymptotically excellent performance and parallelizable decoding compared to a turbo code.

Generally, an LDPC code is defined by a low-density parity check matrix (PCM) that is randomly generated. However, a randomly generated LDPC code requires a large amount of memory to store a PCM, and requires a lot of time to access memory. In order to overcome these problems, a quasi-cyclic LDPC (QC-LDPC) code has been proposed. A QC-LDPC code that is composed of a zero matrix or a circulant permutation matrix (CPM) is defined by a PCM that is expressed by the following Equation 1:

$$H = \begin{bmatrix} J^{a_{11}} & J^{a_{12}} & \dots & J^{a_{1n}} \\ J^{a_{21}} & J^{a_{22}} & \dots & J^{a_{2n}} \\ \vdots & \vdots & \ddots & \vdots \\ J^{a_{m1}} & J^{a_{m2}} & \dots & J^{a_{mn}} \end{bmatrix}, \text{ for } a_{ij} \in \{0, 1, \dots, L-1, \infty\} \quad (1)$$

In this equation, J is a CPM having a size of L×L, and is given as the following Equation 2. In the following description, L may be 360.

$$J_{L \times L} = \begin{bmatrix} 0 & 1 & 0 & \dots & 0 \\ 0 & 0 & 1 & \dots & 0 \\ \vdots & \vdots & \vdots & \ddots & \vdots \\ 0 & 0 & 0 & \dots & 1 \\ 1 & 0 & 0 & \dots & 0 \end{bmatrix} \quad (2)$$

Furthermore, J^i is obtained by shifting an L×L identity matrix $I(J^0)$ to the right i ($0 \leq i < L$) times, and J^∞ is an L×L zero matrix. Accordingly, in the case of a QC-LDPC code, it is sufficient if only index exponent i is stored in order to store J^i , and thus the amount of memory required to store a PCM is considerably reduced.

FIG. 3 is a diagram illustrating the structure of a PCM corresponding to an LDPC code to according to an embodiment of the present invention.

Referring to FIG. 3, the sizes of matrices A and C are g×K and (N-K-g)×(K+g), respectively, and are composed of an L×L zero matrix and a CPM, respectively. Furthermore, matrix Z is a zero matrix having a size of g×(N-K-g),

6

matrix D is an identity matrix having a size of (N-K-g)×(N-K-g), and matrix B is a dual diagonal matrix having a size of g×g. In this case, the matrix B may be a matrix in which all elements except elements along a diagonal line and neighboring elements below the diagonal line are 0, and may be defined as the following Equation 3:

$$B_{g \times g} = \begin{bmatrix} I_{L \times L} & 0 & 0 & \dots & 0 & 0 & 0 \\ I_{L \times L} & I_{L \times L} & 0 & \dots & 0 & 0 & 0 \\ 0 & I_{L \times L} & I_{L \times L} & \vdots & 0 & 0 & 0 \\ \vdots & \vdots & \vdots & \ddots & \vdots & \vdots & \vdots \\ 0 & 0 & 0 & \dots & I_{L \times L} & I_{L \times L} & 0 \\ 0 & 0 & 0 & \dots & 0 & I_{L \times L} & I_{L \times L} \end{bmatrix} \quad (3)$$

where $I_{L \times L}$ is an identity matrix having a size of L×L.

That is, the matrix B may be a bit-wise dual diagonal matrix, or may be a block-wise dual diagonal matrix having identity matrices as its blocks, as indicated by Equation 3. The bit-wise dual diagonal matrix is disclosed in detail in Korean Patent Application Publication No. 2007-0058438, etc.

In particular, it will be apparent to those skilled in the art that when the matrix B is a bit-wise dual diagonal matrix, it is possible to perform conversion into a Quasi-cyclic form by applying row or column permutation to a PCM including the matrix B and having a structure illustrated in FIG. 3.

In this case, N is the length of a codeword, and K is the length of information.

The present invention proposes a newly designed QC-LDPC code in which the code rate thereof is 2/15 and the length of a codeword is 64800, as illustrated in the following Table 1. That is, the present invention proposes an LDPC code that is designed to receive information having a length of 8640 and generate an LDPC codeword having a length of 64800.

Table 1 illustrates the sizes of the matrices A, B, C, D and Z of the QC-LDPC code according to the present invention:

TABLE 1

Code rate	Length	Sizes				
		A	B	C	D	Z
2/15	64800	1800 × 8640	1800 × 1800	54360 × 10440	54360 × 54360	1800 × 54360

The newly designed LDPC code may be represented in the form of a sequence (progression), an equivalent relationship is established between the sequence and matrix (parity bit check matrix), and the sequence may be represented, as follows:

Sequence Table

1st row:	615 898 1029 6129 8908 10620 13378 14359 21964 23319 26427 26690 28128 33435 36080 40697 43525 44498 50994
2nd row:	165 1081 1637 2913 8944 9639 11391 17341 22000 23580 32309 38495 41239 44079 47395 47460 48282 51744 52782
3rd row:	426 1340 1493 2261 10903 13336 14755 15244 20543 29822 35283 38846 45368 46642 46934 48242 49000 49204 53370
4th row:	407 1059 1366 2004 5985 9217 9321 13576 19659 20808 30009 31094 32445 39094 39357 40651 44358 48755 49732
5th row:	692 950 1444 2967 3929 6951 10157 10326 11547 13562 19634 34484 38236 42918 44685 46172 49694 50535 55109
6th row:	1087 1458 1574 2335 3248 6965 17856 23454 25182

-continued

Sequence Table

37359 37718 37768 38061 38728 39437 40710 46298 50707 51572
7th row: 1098 1540 1711 7723 9549 9986 16369 19567 21185
21319 25750 32222 32463 40342 41391 43869 48372 52149 54722
8th row: 514 1283 1635 6602 11333 11443 17690 21036 22936
24525 25425 27103 28733 29551 39204 42525 49200 54899 54961
9th row: 357 609 1096 2954 4240 5397 8425 13974 15252 20167
20362 21623 27190 42744 47819 49096 51995 55504 55719
10th row: 25 448 1501 11572 13478 24338 29198 29840 31428
33088 34724 37698 37988 38297 40482 46953 47880 53751 54943
11st row: 328 1096 1262 10802 12797 16053 18038 20433 20444
25422 32992 34344 38326 41435 46802 48766 49807 52966 55751
12nd row: 34 790 987 5082 5788 10778 12824 18217 23278 24737
28312 34464 36765 37999 39603 40797 43237 53089 55319
13rd row: 226 1149 1470 3483 8949 9312 9773 13271 17804
20025 20323 30623 38575 39887 40305 46986 47223 49998 52111
14th row: 1088 1091 1757 2682 5526 5716 9665 10733 12997
14440 24665 27990 30203 33173 37423 38934 40494 45418 48393
15th row: 809 1278 1580 3486 4529 6117 6212 6823 7861
9244 11559 20736 30333 32450 35528 42968 44485 47149 54913
16th row: 369 525 1622 2261 6454 10483 11259 16461 17031
20221 22710 25137 26622 27904 30884 31858 44121 50690 56000
17th row: 423 1291 1352 7883 26107 26157 26876 27071 31515
35340 35953 36608 37795 37842 38527 41720 46206 47998 53019
18th row: 540 662 1433 2828 14410 22880 24263 24802 28242
28396 35928 37214 39748 43915 44905 46590 48684 48890 55926
19th row: 214 1291 1622 7311 8985 20952 22752 23261 24896
25057 28826 37074 37707 38742 46026 51116 51521 52956 54213
20th row: 109 1305 1676 2594 7447 8943 14806 16462 19730 23430
24542 34300 36432 37133 41199 43942 45860 47598 48401 49407
21st row: 242 388 1360 6721 14220 21029 22536 25126 32251 33182
39192 42436 44144 45252 46238 47369 47607 47695 50635 51469
22nd row: 199 958 1111 13661 18809 19234 21459 25221 25837 28256
36919 39031 39107 39262 43572 45018 45959 48006 52387 55811
23rd row: 668 1087 1451 2945 3319 12519 21248 21344 22627 22701
28152 29670 31430 32655 38533 42233 43200 44013 44459 51398
24th row: 244 1133 1665 8222 8740 11285 12774 15922 20147 20978
28927 35086 40197 40583 41066 41223 42104 44650 45391 48437
25th row: 5623 8050 9679 12978 15846 16049 21807 23364
27226 27758 28661 38147 46337 48141 51364 51927 55124
26th row: 10369 13704 14491 18632 19430 21218 33392 36182
36722 37342 37415 46322 47449 51136 53392 54356 55108
27th row: 7460 9411 11132 11739 13722 15501 25588 26463
26738 31980 31981 35002 39659 39783 41581 51358 55114
28th row: 8915 15253 15264 16513 16896 18367 19110 23492
32074 33302 42443 43797 44715 47538 48515 53464 53548
29th row: 5884 8910 10123 11311 13654 14207 16122 18113
23100 23784 24825 39629 46372 52454 52799 55039 55973

An LDPC code that is represented in the form of a sequence is being widely used in the DVB standard.

According to an embodiment of the present invention, an LDPC code presented in the form of a sequence is encoded, as follows. It is assumed that there is an information block $S=(s_0, s_1, \dots, s_{K-1})$ having an information size K . The LDPC encoder generates a codeword $\Lambda=(\lambda_0, \lambda_1, \lambda_2, \dots, \lambda_{N-1})$ having a size of $N=K+M_1+M_2$ using the information block S having a size K . In this case, $M_1=g$, and $M_2=N-K-g$. Furthermore, M_1 is the size of parity bits corresponding to the dual diagonal matrix B , and M_2 is the size of parity bits corresponding to the identity matrix D . The encoding process is performed, as follows:

Initialization:

$$\lambda_i = s_i \text{ for } i=0,1, \dots, K-1$$

$$p_j = 0 \text{ for } j=0,1, \dots, M_1+M_2-1 \quad (4)$$

First information bit λ_0 is accumulated at parity bit addresses specified in the 1st row of the sequence of the Sequence Table. For example, in an LDPC code having a

length of 64800 and a code rate of 2/15, an accumulation process is as follows:

$$p_{615} = p_{615} \oplus \lambda_0, p_{898} = p_{898} \oplus \lambda_0, p_{1029} = p_{1029} \oplus \lambda_0$$

$$p_{6129} = p_{6129} \oplus \lambda_0, p_{8908} = p_{8908} \oplus \lambda_0$$

$$p_{10620} = p_{10620} \oplus \lambda_0, p_{13378} = p_{13378} \oplus \lambda_0$$

$$p_{14359} = p_{14359} \oplus \lambda_0, p_{21964} = p_{21964} \oplus \lambda_0$$

$$p_{23319} = p_{23319} \oplus \lambda_0$$

$$p_{26427} = p_{26427} \oplus \lambda_0, p_{26690} = p_{26690} \oplus \lambda_0$$

$$p_{28128} = p_{28128} \oplus \lambda_0, p_{33435} = p_{33435} \oplus \lambda_0$$

$$p_{36080} = p_{36080} \oplus \lambda_0$$

$$p_{40697} = p_{40697} \oplus \lambda_0, p_{43525} = p_{43525} \oplus \lambda_0$$

$$p_{44498} = p_{44498} \oplus \lambda_0, p_{50994} = p_{50994} \oplus \lambda_0$$

where the addition \oplus occurs in GF(2).

The subsequent $L-1$ information bits, that is, λ_m , $m=1, 2, \dots, L-1$, are accumulated at parity bit addresses that are calculated by the following Equation 5:

$$(x+m \times Q_1) \bmod M_1 \text{ if } x < M_1$$

$$M_1 + \{(x-M_1+m \times Q_2) \bmod M_2\} \text{ if } x \geq M_1 \quad (5)$$

where x denotes the addresses of parity bits corresponding to the first information bit λ_0 , that is, the addresses of the parity bits specified in the first row of the sequence of the Sequence Table, $Q_1=M_1/L$, $Q_2=M_2/L$, and $L=360$. Furthermore, Q_1 and Q_2 are defined in the following Table 2. For example, for an LDPC code having a length of 64800 and a code rate of 2/15, $M_1=1800$, $Q_1=5$, $M_2=54360$, $Q_2=151$ and $L=360$, and the following operations are performed on the second bit λ_1 using Equation 5:

$$p_{620} = p_{620} \oplus \lambda_1, p_{903} = p_{903} \oplus \lambda_1, p_{1034} = p_{1034} \oplus \lambda_1$$

$$p_{6280} = p_{6280} \oplus \lambda_1, p_{9059} = p_{9059} \oplus \lambda_1$$

$$p_{10771} = p_{10771} \oplus \lambda_1, p_{13529} = p_{13529} \oplus \lambda_1$$

$$p_{14510} = p_{14510} \oplus \lambda_1, p_{22115} = p_{22115} \oplus \lambda_1$$

$$p_{23470} = p_{23470} \oplus \lambda_1$$

$$p_{26578} = p_{26578} \oplus \lambda_1, p_{26841} = p_{26841} \oplus \lambda_1$$

$$p_{28279} = p_{28279} \oplus \lambda_1, p_{33586} = p_{33586} \oplus \lambda_1$$

$$p_{36321} = p_{36321} \oplus \lambda_1$$

$$p_{40848} = p_{40848} \oplus \lambda_1, p_{43676} = p_{43676} \oplus \lambda_1$$

$$p_{44649} = p_{44649} \oplus \lambda_1, p_{51145} = p_{51145} \oplus \lambda_1$$

Table 2 illustrates the sizes of M_1 , Q_1 , M_2 and Q_2 of the designed QC-LDPC code:

TABLE 2

Code rate	Length	Sizes			
		M_1	M_2	Q_1	Q_2
2/15	64800	1800	54360	5	151

The addresses of parity bit accumulators for new 360 information bits from λ_L to λ_{2L-1} are calculated and accumulated from Equation 5 using the second row of the sequence.

In a similar manner, for all groups composed of new L information bits, the addresses of parity bit accumulators are calculated and accumulated from Equation 5 using new rows of the sequence.

After all the information bits from λ_0 to λ_{K-1} have been exhausted, the operations of the following Equation 6 are sequentially performed from $i=1$:

$$p_i = p_i \oplus p_{i-1} \text{ for } i=0,1, \dots, M_1-1 \quad (6)$$

Thereafter, when a parity interleaving operation, such as that of the following Equation 7, is performed, parity bits corresponding to the dual diagonal matrix B are generated:

$$\lambda_{K+L-t+s} = p_{Q_1, s+t} \text{ for } 0 \leq s < L, 0 \leq t < Q_1 \quad (7)$$

When the parity bits corresponding to the dual diagonal matrix B have been generated using K information bits $\lambda_0, \lambda_1, \dots, \lambda_{K-1}$, parity bits corresponding to the identity matrix D are generated using the M_1 generated parity bits $\lambda_K, \lambda_{K+1}, \dots, \lambda_{K+M_1-1}$.

For all groups composed of L information bits from λ_K to λ_{K+M_1-1} , the addresses of parity bit accumulators are calculated using the new rows (starting with a row immediately subsequent to the last row used when the parity bits corresponding to the dual diagonal matrix B have been generated) of the sequence and Equation 5, and related operations are performed.

When a parity interleaving operation, such as that of the following Equation 8, is performed after all the information bits from λ_K to λ_{K+M_1-1} have been exhausted, parity bits corresponding to the identity matrix D are generated:

$$\lambda_{K+M_1+L-t+s} = p_{M_1+Q_2, s+t} \text{ for } 0 \leq s < L, 0 \leq t < Q_2 \quad (8)$$

FIG. 4 is a diagram illustrating the bit groups of an LDPC codeword having a length of 64800.

Referring to FIG. 4, it can be seen that an LDPC codeword having a length of 64800 is divided into 180 bit groups (a 0th group to a 179th group).

In this case, 360 may be the parallel factor (PF) of the LDPC codeword. That is, since the PF is 360, the LDPC codeword having a length of 64800 is divided into 180 bit groups, as illustrated in FIG. 4, and each of the bit groups includes 360 bits.

FIG. 5 is a diagram illustrating the bit groups of an LDPC codeword having a length of 16200.

Referring to FIG. 5, it can be seen that an LDPC codeword having a length of 16200 is divided into 45 bit groups (a 0th group to a 44th group).

In this case, 360 may be the parallel factor (PF) of the LDPC codeword. That is, since the PF is 360, the LDPC codeword having a length of 16200 is divided into 45 bit groups, as illustrated in FIG. 5, and each of the bit groups includes 360 bits.

FIG. 6 is a diagram illustrating interleaving that is performed on a bit group basis in accordance with an interleaving sequence.

Referring to FIG. 6, it can be seen that interleaving is performed by changing the order of bit groups by a designed interleaving sequence.

For example, it is assumed that an interleaving sequence for an LDPC codeword having a length of 16200 is as follows:

$$\text{interleaving sequence} = \{24 \ 34 \ 15 \ 11 \ 2 \ 28 \ 17 \ 25 \ 5 \ 38 \\ 19 \ 13 \ 6 \ 39 \ 1 \ 14 \ 33 \ 37 \ 29 \ 12 \ 42 \ 31 \ 30 \ 32 \ 36 \\ 40 \ 26 \ 35 \ 44 \ 4 \ 16 \ 8 \ 20 \ 43 \ 21 \ 70 \ 18 \ 23 \ 3 \ 10 \ 41 \\ 9 \ 27 \ 22\}$$

Then, the order of the bit groups of the LDPC codeword illustrated in FIG. 4 is changed into that illustrated in FIG. 6 by the interleaving sequence.

That is, it can be seen that each of the LDPC codeword **610** and the interleaved codeword **620** includes 45 bit groups, and it can be also seen that, by the interleaving sequence, the 24th bit group of the LDPC codeword **610** is changed into the 0th bit group of the interleaved LDPC codeword **620**, the 34th bit group of the LDPC codeword **610** is changed into the 1st bit group of the interleaved LDPC codeword **620**, the 15th bit group of the LDPC

codeword **610** is changed into the 2nd bit group of the interleaved LDPC codeword **620**, and the 1st bit group of the LDPC codeword **610** is changed into the 3rd bit group of the interleaved LDPC codeword **620**, and the 2nd bit group of the LDPC codeword **610** is changed into the 4th bit group of the interleaved LDPC codeword **620**.

An LDPC codeword ($u_0, u_1, \dots, u_{N_{ldpc}-1}$) having a length of N_{ldpc} is divided into $N_{group} = N_{ldpc} / 360$ bit groups, as in Equation 9 below:

$$X_j = \{u_k | 360 \times j \leq k < 360 \times (j+1), 0 \leq k < N_{ldpc}\} \text{ for } 0 \leq j < N_{group} \quad (9)$$

where X_j is a j-th bit group, and each X_j is composed of 360 bits.

The LDPC codeword divided into the bit groups is interleaved, as in Equation 10 below:

$$Y_j = X_{\pi(j)}, 0 \leq j \leq N_{group} \quad (10)$$

where Y_j is an interleaved j-th bit group, and $\pi(j)$ is a permutation order for bit group-based interleaving (bit group-unit interleaving). The permutation order corresponds to the interleaving sequence of Equation 11 below:

$$\text{interleaving sequence} = \{157 \ 25 \ 107 \ 160 \ 37 \ 138 \ 111 \\ 35 \ 29 \ 44 \ 15 \ 162 \ 66 \ 20 \ 49 \ 126 \ 89 \ 147 \ 159 \ 174 \\ 142 \ 26 \ 146 \ 10 \ 164 \ 152 \ 57 \ 110 \ 83 \ 167 \ 169 \ 16 \\ 6 \ 172 \ 62 \ 173 \ 7 \ 145 \ 4 \ 67 \ 115 \ 50 \ 39 \ 72 \ 79 \ 74 \\ 40 \ 132 \ 42 \ 30 \ 163 \ 161 \ 55 \ 143 \ 63 \ 117 \ 86 \ 121 \ 2 \\ 28 \ 69 \ 150 \ 24 \ 177 \ 43 \ 158 \ 27 \ 21 \ 128 \ 46 \ 118 \\ 114 \ 127 \ 135 \ 92 \ 76 \ 19 \ 94 \ 179 \ 3 \ 52 \ 101 \ 137 \ 84 \\ 73 \ 108 \ 91 \ 120 \ 47 \ 1 \ 102 \ 58 \ 68 \ 82 \ 59 \ 119 \ 64 \ 31 \\ 61 \ 105 \ 103 \ 151 \ 124 \ 70 \ 8 \ 155 \ 90 \ 166 \ 41 \ 45 \\ 178 \ 113 \ 140 \ 75 \ 148 \ 109 \ 100 \ 125 \ 11 \ 116 \ 34 \ 36 \\ 176 \ 170 \ 156 \ 136 \ 171 \ 122 \ 78 \ 87 \ 106 \ 123 \ 149 \\ 17 \ 99 \ 175 \ 18 \ 9 \ 165 \ 153 \ 12 \ 81 \ 77 \ 60 \ 93 \ 104 \ 13 \\ 5 \ 88 \ 96 \ 141 \ 133 \ 154 \ 144 \ 48 \ 97 \ 23 \ 14 \ 98 \ 53 \\ 134 \ 112 \ 65 \ 0 \ 130 \ 32 \ 168 \ 33 \ 131 \ 22 \ 38 \ 56 \ 80 \\ 95 \ 71 \ 85 \ 139 \ 129 \ 51 \ 54\} \quad (11)$$

That is, when each of the codeword and the interleaved codeword includes 180 bit groups ranging from a 0th bit group to a 179th bit group, the interleaving sequence of Equation 11 means that the 157th bit group of the codeword becomes the 0th bit group of the interleaved codeword, the 25th bit group of the codeword becomes the 1st bit group of the interleaved codeword, the 107th bit group of the codeword becomes the 2nd bit group of the interleaved codeword, the 160th bit group of the codeword becomes the 3rd bit group of the interleaved codeword, . . . , the 51st bit group of the codeword becomes the 178th bit group of the interleaved codeword, and the 54th bit group of the codeword becomes the 179th bit group of the interleaved codeword.

In particular, the interleaving sequence of Equation 11 has been optimized for a case where 1024-symbol mapping (NUC symbol mapping) is employed and an LDPC coder having a length of 64800 and a code rate of 2/15 is used.

FIG. 7 is a block diagram illustrating a bit interleaver according to an embodiment of the present invention.

Referring to FIG. 7, the bit interleaver according to the present embodiment includes memories **710** and **730** and a processor **720**.

The memory **710** stores an LDPC codeword having a length of 64800 and a code rate of 2/15.

The processor **720** generates an interleaved codeword by interleaving the LDPC codeword on a bit group basis corresponding to the parallel factor of the LDPC codeword.

In this case, the parallel factor may be 360. In this case, each of the bit groups may include 360 bits.

In this case, the LDPC codeword may be divided into 180 bit groups, as in Equation 9.

11

In this case, the interleaving may be performed using Equation 10 using permutation order.

In this case, the permutation order may correspond to the interleaving sequence represented by Equation 11.

The memory 730 provides the interleaved codeword to a modulator for 1024-symbol mapping.

In this case, the modulator may be a symbol mapping device performing NUC (Non-Uniform Constellation) symbol mapping.

The memories 710 and 730 may correspond to various types of hardware for storing a set of bits, and may correspond to a data structure, such as an array, a list, a stack, a queue or the like.

In this case, the memories 710 and 730 may not be physically separate devices, but may correspond to different addresses of a physically single device. That is, the memories 710 and 730 are not physically distinguished from each other, but are merely logically distinguished from each other.

The error-correction coder 13 illustrated in FIG. 1 may be implemented in the same structure as in FIG. 7.

That is, the error-correction coder may include memories and a processor. In this case, the first memory is a memory that stores an LDPC codeword having a length of 64800 and a code rate of 2/15, and a second memory is a memory that is initialized to 0.

The memories may correspond to λ_i ($i=0, 1, \dots, N-1$) and P_j ($j=0, 1, \dots, M_1+M_2-1$), respectively.

The processor may generate an LDPC codeword corresponding to information bits by performing accumulation with respect to the memory using a sequence corresponding to a parity check matrix (PCM).

In this case, the accumulation may be performed at parity bit addresses that are updated using the sequence of the above Sequence Table.

In this case, the LDPC codeword may include a systematic part $\lambda_0, \lambda_1, \dots, \lambda_K$, corresponding to the information bits and having a length of 8640 ($=K$), a first parity part $\lambda_K, \lambda_{K+1}, \dots, \lambda_{K+M_1-1}$ corresponding to a dual diagonal matrix included in the PCM and having a length of 1800 ($=M_1=g$), and a second parity part $\lambda_{K+M_1}, \lambda_{K+M_1+1}, \dots, \lambda_{K+M_1+M_2-1}$ corresponding to an identity matrix included in the PCM and having a length of 54360 ($=M_2$).

In this case, the sequence may have a number of rows equal to the sum ($8640/360+1800/360=29$) of a value obtained by dividing the length of the systematic part, i.e., 8640, by a CPM size L corresponding to the PCM, i.e., 360, and a value obtained by dividing the length M_1 of the first parity part, i.e., 1800, by 360.

As described above, the sequence may be represented by the above Sequence Table.

In this case, the second memory may have a size corresponding to the sum M_1+M_2 of the length M_1 of the first parity part and the length M_2 of the second parity part.

In this case, the parity bit addresses may be updated based on the results of comparing each x of the previous parity bit addresses, specified in respective rows of the sequence, with the length M_1 of the first parity part.

That is, the parity bit addresses may be updated using Equation 5. In this case, x may be the previous parity bit addresses, m may be an information bit index that is an integer larger than 0 and smaller than L, L may be the CPM size of the PCM, Q_1 may be M_1/L , M_1 may be the size of the first parity part, Q_2 may be M_2/L , and M_2 may be the size of the second parity part.

In this case, it may be possible to perform the accumulation while repeatedly changing the rows of the sequence by the CPM size L ($=360$) of the PCM, as described above.

12

In this case, the first parity part $\lambda_K, \lambda_{K+1}, \dots, \lambda_{K+M_1-1}$ may be generated by performing parity interleaving using the first memory and the second memory, as described in conjunction with Equation 7.

In this case, the second parity part $\lambda_K, \lambda_{K+1}, \dots, \lambda_{K+M_1+M_2-1}$ may be generated by performing parity interleaving using the first memory and the second memory after generating the first parity part $\lambda_K, \lambda_{K+1}, \dots, \lambda_{K+M_1-1}$ and then performing the accumulation using the first parity part $\lambda_K, \lambda_{K+1}, \dots, \lambda_{K+M_1-1}$ and the sequence, as described in conjunction with Equation 8.

FIG. 8 is an operation flowchart illustrating a bit interleaving method according to an embodiment of the present invention.

Referring to FIG. 8, in the bit interleaving method according to the present embodiment, an LDPC codeword having a length of 64800 and a code rate of 2/15 is stored at step S810.

In this case, the LDPC codeword may be represented by $(u_0, u_1, \dots, u_{N_{ldpc}-1})$ (where N_{ldpc} is 64800), and may be divided into 180 bit groups each composed of 360 bits, as in Equation 9.

Furthermore, in the bit interleaving method according to the present embodiment, an interleaved codeword is generated by interleaving the LDPC codeword on a bit group basis at step S820.

In this case, the size of the bit group may correspond to the parallel factor of the LDPC codeword.

In this case, the interleaving may be performed using Equation 10 using permutation order.

In this case, the permutation order may correspond to the interleaving sequence represented by Equation 11.

In this case, the parallel factor may be 360, and each of the bit groups may include 360 bits.

In this case, the LDPC codeword may be divided into 180 bit groups, as in Equation 9.

Moreover, in the bit interleaving method according to the present embodiment, the interleaved codeword is output to a modulator for 1024-symbol mapping at step 830.

In accordance with at least one embodiment of the present invention, there is provided an intra-BICM bit interleaver that can effectively distribute burst errors occurring in a broadcasting system channel.

In accordance with at least one embodiment of the present invention, there is provided a bit interleaver that is optimized for an LDPC coder having a length of 64800 and a code rate of 2/15 and a modulator performing 1024-symbol mapping and, thus, can be applied to next-generation broadcasting systems, such as ATSC 3.0.

Although the specific embodiments of the present invention have been disclosed for illustrative purposes, those skilled in the art will appreciate that various modifications, additions and substitutions are possible without departing from the scope and spirit of the invention as disclosed in the accompanying claims.

What is claimed is:

1. A bit-interleaved coded modulation (BICM) reception device, comprising:

a demodulator configured to perform demodulation corresponding to 1024-symbol mapping after receiving a broadcasting signal;

a bit deinterleaver configured to perform group-unit deinterleaving on interleaved values, the interleaved values generated after the demodulation; and

a decoder configured to restore information bits by Low-Density Parity Check (LDPC)-decoding deinterleaved values generated based on the group-unit deinterleav-

13

ing, the deinterleaved values corresponding to a LDPC codeword having a length of 64800 and a code rate of 2/15,

wherein the group-unit deinterleaving is performed on a group basis, the size of the group corresponding to a parallel factor of the LDPC codeword,

wherein the group-unit deinterleaving corresponds to a reverse process of interleaving performed by the following equation using a permutation order, the reverse process being for recovering an original order before the interleaving,

$$Y_j = X_{\lambda(j)} \quad 0 \leq j \leq N_{group}$$

where $X_{\lambda(j)}$ is a $\lambda(j)$ th bit group Y_j is interleaved J -th bit group N_{group} is the number of bit groups obtained by dividing the LDPC codeword into the bit groups, and $\lambda(j)$ is the permutation order for bit group-based interleaving,

wherein the permutation order corresponds to an interleaving sequence represented by the following interleaving sequence = {157 25 107 160 37 138 111 35 29 44 15 162 66 20 49 126 89 147 159 174 142 26 146 10 164 152 57 110 83 167 169 16 6 172 62 173 7 145 4 67 115 50 39 72 79 74 40 132 42 30 163 161 55 143 63 117 86 121 2 28 69 150 24 177 43 158 27 21 128 46 118 114 127 135 92 76 19 94 179 3 52 101 137 84 73 108 91 120 47 1 102 58 68 82 59 119 64 31 61 105 103 151 124 70 8 155 90 166 41 45 178 113 140 75 148 109 100 125 11 116 34 36 176 170 156 136 171 122 78 87 106 123 149 17 99 175 18 9 165 153 12 81 77 60 93 104 13 5 88 96 141 133 154 144 48 97 23 14 98 53 134 112 65 0 130 32 168 33 131 22 38 56 80 95 71 85 139 129 51 54}, and

wherein the interleaving is performed corresponding to the interleaving sequence so as to distribute burst errors occurring in the broadcasting signal when the broadcasting signal is transmitted over a physical channel.

2. The BICM reception device of claim 1, wherein the 1024-symbol mapping is a Non-Uniform Constellation (NUC) symbol mapping which corresponds to 1024 constellations.

3. The BICM reception device of claim 2, wherein the parallel factor is 360, and the group includes 360 values.

4. The BICM reception device of claim 3, wherein the LDPC codeword is represented by $(u_0, u_1, \dots, u_{N_{ldpc}-1})$ ($u_0, u_1, \dots, u_{N_{ldpc}-1}$), and the group corresponds to a bit group of the LDPC codeword in the following equation:

$$X_j = \{u_k | 360 \times j \leq k < 360 \times (j+1), 0 \leq k < N_{ldpc}\} \text{ for } 0 \leq j < N_{group}$$

14

where X_j is a j -th bit group, N_{ldpc} is 64800, and N_{group} is 180.

5. A bit-interleaved coded modulation (BICM) reception method, the method comprising:

performing demodulation corresponding to 1024-symbol mapping after receiving a broadcasting signal;

performing group-unit deinterleaving on interleaved values, the interleaved values generated after the demodulation; and

restoring information bits by Low-Density Parity Check (LDPC)-decoding deinterleaved values generated based on the group-unit deinterleaving, the deinterleaved values corresponding to a LDPC codeword having a length of 64800 and a code rate of 2/15,

wherein the group-unit deinterleaving is performed on a group basis, the size of the group corresponding to a parallel factor of the LDPC codeword,

wherein the group-unit deinterleaving corresponds to a reverse process of interleaving performed by the following equation using a permutation order, the reverse process being for recovering an original order before the interleaving,

$$Y_j = X_{\lambda(j)} \quad 0 \leq j \leq N_{group}$$

where $X_{\lambda(j)}$ is a $\lambda(j)$ th bit group, Y_j is an interleaved j -th bit group, N_{group} is the number of bit groups obtained by dividing the LDPC codeword into the bit groups, and $\lambda(j)$ is the permutation order for bit group-based interleaving,

wherein the permutation order corresponds to an interleaving sequence represented by the following

interleaving sequence = {157 25 107 160 37 138 111 35 29 44 15 162 66 20 49 126 89 147 159 174 142 26 146 10 164 152 57 110 83 167 169 16 6 172 62 173 7 145 4 67 115 50 39 72 79 74 40 132 42 30 163 161 55 143 63 117 86 121 2 28 69 150 24 177 43 158 27 21 128 46 118 114 127 135 92 76 19 94 179 3 52 101 137 84 73 108 91 120 47 1 102 58 68 82 59 119 64 31 61 105 103 151 124 70 8 155 90 166 41 45 178 113 140 75 148 109 100 125 11 116 34 36 176 170 156 136 171 122 78 87 106 123 149 17 99 175 18 9 165 153 12 81 77 60 93 104 13 5 88 96 141 133 154 144 48 97 23 14 98 53 134 112 65 0 130 32 168 33 131 22 38 56 80 95 71 85 139 129 51 54}, and

wherein the interleaving is performed corresponding to the interleaving sequence so as to distribute burst errors occurring in the broadcasting signal when the broadcasting signal is transmitted over a physical channel.

* * * * *