



US011257498B2

(12) **United States Patent**  
**Gruenstein et al.**

(10) **Patent No.:** **US 11,257,498 B2**  
(45) **Date of Patent:** **\*Feb. 22, 2022**

(54) **RECORDED MEDIA HOTWORD TRIGGER SUPPRESSION**

(71) Applicant: **Google LLC**, Mountain View, CA (US)

(72) Inventors: **Alexander H. Gruenstein**, Mountain View, CA (US); **Johan Schalkwyk**, Scarsdale, NY (US); **Matthew Sharifi**, Kilchberg (CH)

(73) Assignee: **Google LLC**, Mountain View, CA (US)

(\*) Notice: Subject to any disclaimer, the term of this patent is extended or adjusted under 35 U.S.C. 154(b) by 0 days.

This patent is subject to a terminal disclaimer.

(21) Appl. No.: **17/100,109**

(22) Filed: **Nov. 20, 2020**

(65) **Prior Publication Data**

US 2021/0074292 A1 Mar. 11, 2021

**Related U.S. Application Data**

(63) Continuation of application No. 15/799,501, filed on Oct. 31, 2017, now Pat. No. 10,867,600.

(Continued)

(51) **Int. Cl.**

**G10L 15/22** (2006.01)

**G06F 3/16** (2006.01)

(Continued)

(52) **U.S. Cl.**

CPC ..... **G10L 15/22** (2013.01); **G06F 3/167** (2013.01); **G10L 15/08** (2013.01); **G10L 15/30** (2013.01);

(Continued)

(58) **Field of Classification Search**

CPC .... **G10L 15/22**; **G10L 2015/088**; **G06F 3/167**  
See application file for complete search history.

(56) **References Cited**

U.S. PATENT DOCUMENTS

4,363,102 A 12/1982 Holmgren et al.

5,659,665 A 8/1997 Whelpley, Jr.

(Continued)

FOREIGN PATENT DOCUMENTS

JP S59180599 A 10/1984

JP H1152976 A 2/1999

(Continued)

OTHER PUBLICATIONS

'www.dailymail.co.uk' [online] "Not so Smart Now! Watch as Google's Home AI speaker answers back to the firm's own TV ads" Nov. 4, 2016, [Retrieved on Nov. 26, 2019], Retrieved from Internet: URL<https://www.dailymail.co.uk/sciencetech/article-3906652/Not-smart-Watch-Google- <http://www.dailymail.co.uk/sciencetech/article-3906652/Not-smart-Watch-Google-> s-Home-AI-speaker-answers-firm-s-TV-ads.html> 5 pages.

(Continued)

*Primary Examiner* — Bryan S Blankenagel

(74) *Attorney, Agent, or Firm* — Honigman LLP; Brett A. Krueger; Grant Griffith

(57) **ABSTRACT**

Methods, systems, and apparatus, including computer programs encoded on a computer storage medium, for hotword trigger suppression are disclosed. In one aspect, a method includes the actions of receiving, by a microphone of a computing device, audio corresponding to playback of an item of media content, the audio including an utterance of a predefined hotword that is associated with performing an operation on the computing device. The actions further include processing the audio. The actions further include in response to processing the audio, suppressing performance of the operation on the computing device.

**20 Claims, 4 Drawing Sheets**

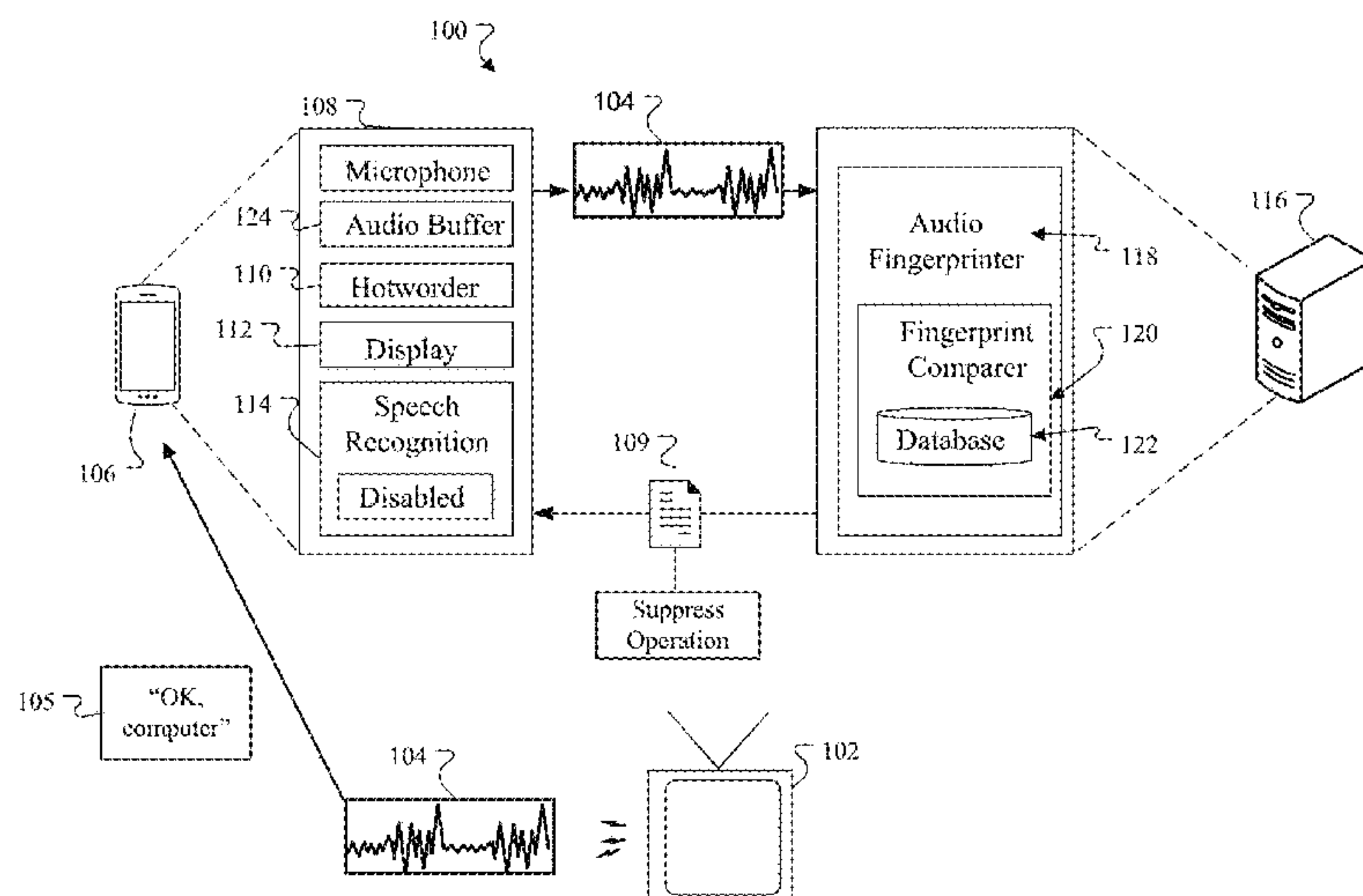

**Related U.S. Application Data**

- (60) Provisional application No. 62/497,044, filed on Nov. 7, 2016.
- (51) **Int. Cl.**  
*G10L 15/08* (2006.01)  
*G10L 15/30* (2013.01)  
*G10L 25/51* (2013.01)  
*G10L 17/00* (2013.01)
- (52) **U.S. Cl.**  
 CPC ..... *G10L 25/51* (2013.01); *G10L 17/00* (2013.01); *G10L 2015/088* (2013.01); *G10L 2015/223* (2013.01)

(56) **References Cited**

U.S. PATENT DOCUMENTS

5,897,616	A	4/1999	Kanevsky et al.
5,983,186	A	11/1999	Miyazawa et al.
6,141,644	A	10/2000	Kuhn et al.
6,567,775	B1	5/2003	Maali et al.
6,671,672	B1	12/2003	Heck
6,744,860	B1	6/2004	Schrage
6,826,159	B1	11/2004	Shaffer et al.
6,931,375	B1	8/2005	Bossemeyer, Jr. et al.
6,973,426	B1	12/2005	Schier et al.
7,016,833	B2	3/2006	Gable et al.
7,222,072	B2	5/2007	Chang
7,571,014	B1	8/2009	Lambourne et al.
7,720,012	B1	5/2010	Borah et al.
7,904,297	B2	3/2011	Mirkovic et al.
8,099,288	B2	1/2012	Zhang et al.
8,194,624	B2	6/2012	Park et al.
8,200,488	B2	6/2012	Kemp et al.
8,209,174	B2	6/2012	Al-Telmissani
8,214,447	B2	7/2012	Deslippe et al.
8,340,975	B1	12/2012	Rosenberger
8,588,949	B2	11/2013	Lamboume et al.
8,670,985	B2	3/2014	Lindahl et al.
8,700,392	B1	4/2014	Hart et al.
8,713,119	B2	4/2014	Lindahl
8,717,949	B2	5/2014	Crinon et al.
8,719,009	B2	5/2014	Baldwin et al.
8,719,018	B2	5/2014	Dinerstein
8,768,687	B1	7/2014	Quasthoff et al.
8,775,191	B1	7/2014	Sharifi et al.
8,805,890	B2	8/2014	Zhang et al.
8,838,457	B2	9/2014	Cerra et al.
8,938,394	B1	1/2015	Faaborg et al.
8,996,372	B1	3/2015	Secker-Walker et al.
9,142,218	B2	9/2015	Schroeter
9,548,053	B1	1/2017	Basye et al.
9,691,378	B1 *	6/2017	Meyers ..... G10L 15/20
9,728,188	B1 *	8/2017	Rosen ..... G10L 25/51
9,786,294	B1	10/2017	Bezos et al.
10,026,399	B2	7/2018	Gopalan et al.
10,074,364	B1 *	9/2018	Wightman ..... G10L 17/04
10,079,015	B1	9/2018	Lockhart et al.
10,453,460	B1	10/2019	Wightman et al.
2002/0049596	A1	4/2002	Burchard et al.
2002/0072905	A1	6/2002	White et al.
2002/0123890	A1	9/2002	Kopp et al.
2002/0193991	A1	12/2002	Bennett et al.
2003/0200090	A1	10/2003	Kawazoe
2003/0220797	A1	11/2003	Ito
2003/0231746	A1	12/2003	Hunter et al.
2004/0101112	A1	5/2004	Kuo
2005/0165607	A1	7/2005	Di Fabbrizio et al.
2006/0074656	A1	4/2006	Mathias et al.
2006/0085188	A1	4/2006	Goodwin et al.
2006/0184370	A1	8/2006	Kwak et al.
2007/0100620	A1	5/2007	Tavares
2007/0198262	A1	8/2007	Mindlin et al.
2008/0085686	A1	4/2008	Kalik

2008/0252595	A1	10/2008	Boillot
2009/0258333	A1	10/2009	Yu
2009/0292541	A1	11/2009	Daya et al.
2010/0070276	A1	3/2010	Wasserblat et al.
2010/0110834	A1	5/2010	Kim et al.
2011/0026722	A1	2/2011	Jing et al.
2011/0054892	A1	3/2011	Jung et al.
2011/0060587	A1	3/2011	Phillips et al.
2011/0066429	A1	3/2011	Shperling et al.
2011/0184730	A1	7/2011	LeBeau et al.
2011/0304648	A1	12/2011	Kim et al.
2012/0084087	A1	4/2012	Yang et al.
2012/0136923	A1	5/2012	Grube
2012/0232896	A1	9/2012	Taleb et al.
2012/0265528	A1	10/2012	Gruber et al.
2013/0060571	A1	3/2013	Soemo et al.
2013/0124207	A1	5/2013	Sarin et al.
2013/0132086	A1	5/2013	Xu et al.
2013/0183944	A1	7/2013	Mozer et al.
2013/0289996	A1	10/2013	Fry
2013/0325479	A1	12/2013	Krueger et al.
2014/0006825	A1	1/2014	Shenhav
2014/0012573	A1	1/2014	Hung et al.
2014/0012578	A1	1/2014	Morioka
2014/0088961	A1	3/2014	Woodward et al.
2014/0163978	A1	6/2014	Basye et al.
2014/0222430	A1	8/2014	Rao
2014/0249817	A1	9/2014	Hart et al.
2014/0257821	A1	9/2014	Adams et al.
2014/0274211	A1	9/2014	Sejnoha et al.
2014/0278383	A1	9/2014	Fan
2014/0278435	A1	9/2014	Ganong, III et al.
2015/0081295	A1	3/2015	Yun et al.
2015/0154953	A1	6/2015	Bapat et al.
2015/0228274	A1	8/2015	Leppanen et al.
2015/0245154	A1	8/2015	Dadu et al.
2015/0262577	A1	9/2015	Nomura
2015/0379989	A1	12/2015	Balasubramanian et al.
2016/0104483	A1	4/2016	Foerster et al.
2016/0155443	A1	6/2016	Khan et al.
2016/0189715	A1	6/2016	Nishikawa
2016/0260431	A1	9/2016	Newendorp et al.
2016/0275070	A1	9/2016	Corston et al.
2017/0019580	A1	1/2017	Boghosian et al.
2017/0048580	A1	2/2017	Wickramasuriya et al.
2018/0199123	A1	7/2018	Rao et al.

FOREIGN PATENT DOCUMENTS

JP	H11231896	A	8/1999
JP	2000310999	A	11/2000
JP	2005055667	A	3/2005
JP	2006227634	A	8/2006
JP	2011227237	A	11/2011
JP	2014092777	A	5/2014
KR	20140031391	A	3/2014
WO	1998040875	A1	9/1998
WO	2014008194	A1	1/2014
WO	2014107413	A1	7/2014
WO	2014124332	A2	8/2014
WO	2015025330	A1	2/2015
WO	2016057268	A1	4/2016

OTHER PUBLICATIONS

International Preliminary Report on Patentability issued in International Application No. PCT/US2017/058981, dated Sep. 25, 2018, 16 pages.

International Search Report and Written Opinion in International Application No. PCT/US2017/058981, dated Feb. 23, 2018, 15 pages.

Prigg, "Not so smart now! Watch as Google's Home AI speaker answers back to the firm's own TV ads," Daily Mail, dated Nov. 4, 2016, 24 pages.

Auckenthaler et al. "Score Normalization for Text-independent Speaker Verification System," Digital Signal Processing, vol. 10, 2000, 13 pages.



(56)

**References Cited**

OTHER PUBLICATIONS

Extended European Search Report in European Application No. 16207288.8-1914, dated Apr. 4, 2017, 8 pages.

Extended European Search Report issued in Application No. 16195834.3-1910, dated Nov. 23, 2016, 9 pages.

Extended European Search Report issued in European Application No. 16193577.0, dated Nov. 23, 2016, 8 pages.

International Preliminary Report on Patentability in International Application No. PCT/US2015/052860, dated Apr. 11, 2017, 9 pages.

International Preliminary Report on Patentability in International Application No. PCT/US2015/052870, dated Apr. 11, 2017, 8 pages.

International Search Report and Written Opinion in International Application No. PCT/US2015/052860, dated Dec. 8, 2015, 12 pages.

International Search Report and Written Opinion in International Application No. PCT/US2015/052870, dated Dec. 4, 2015, 11 pages.

Jae-Seung, Choi, "Text-dependent Speaker Recognition using Characteristic Vectors in Speech Signal and Normalized Recognition Method," Journal of Korean Institute of Information Technology, 10(5), May 2012, 7 pages (English Abstract).

\* cited by examiner

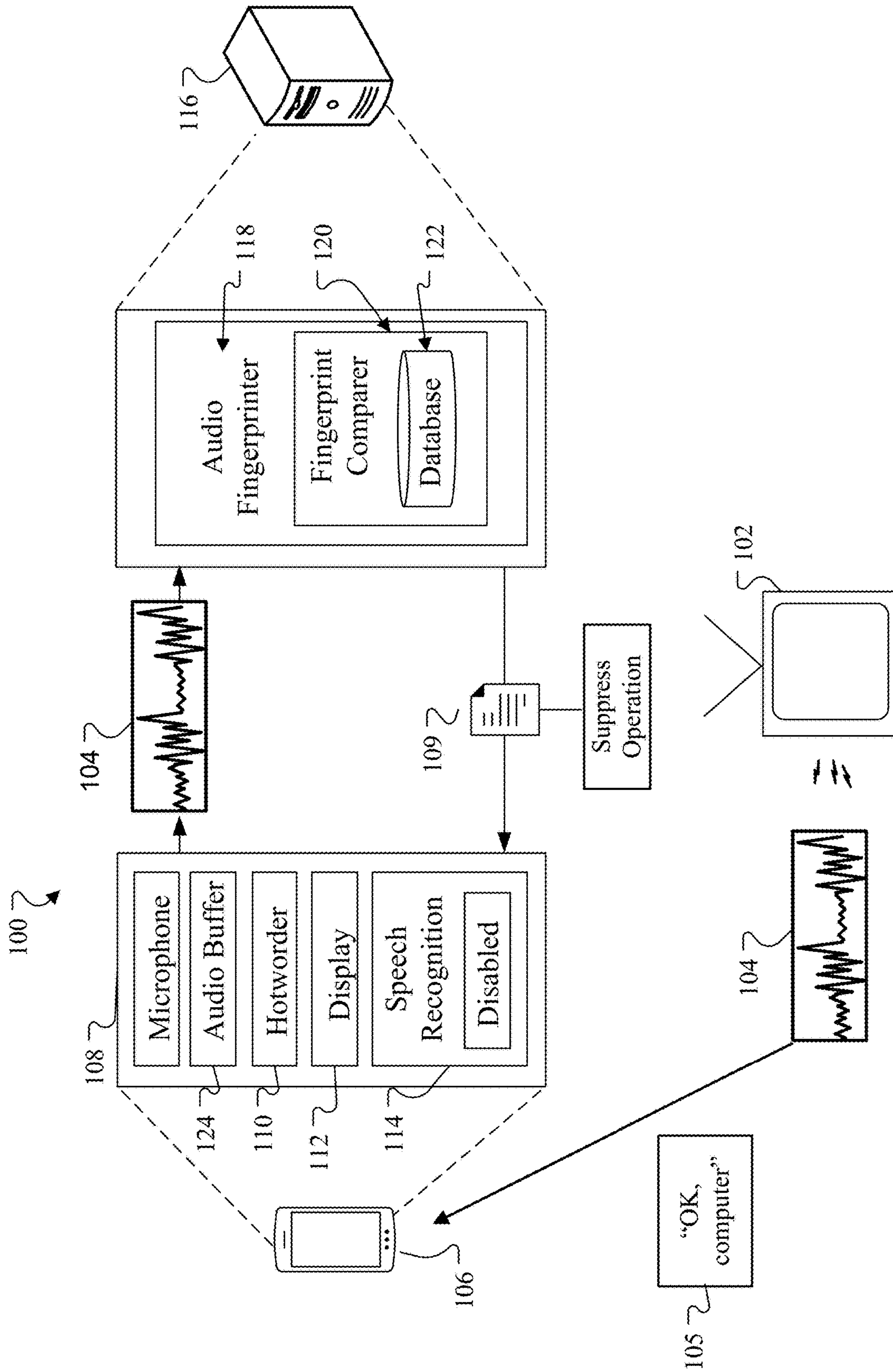

FIG. 1

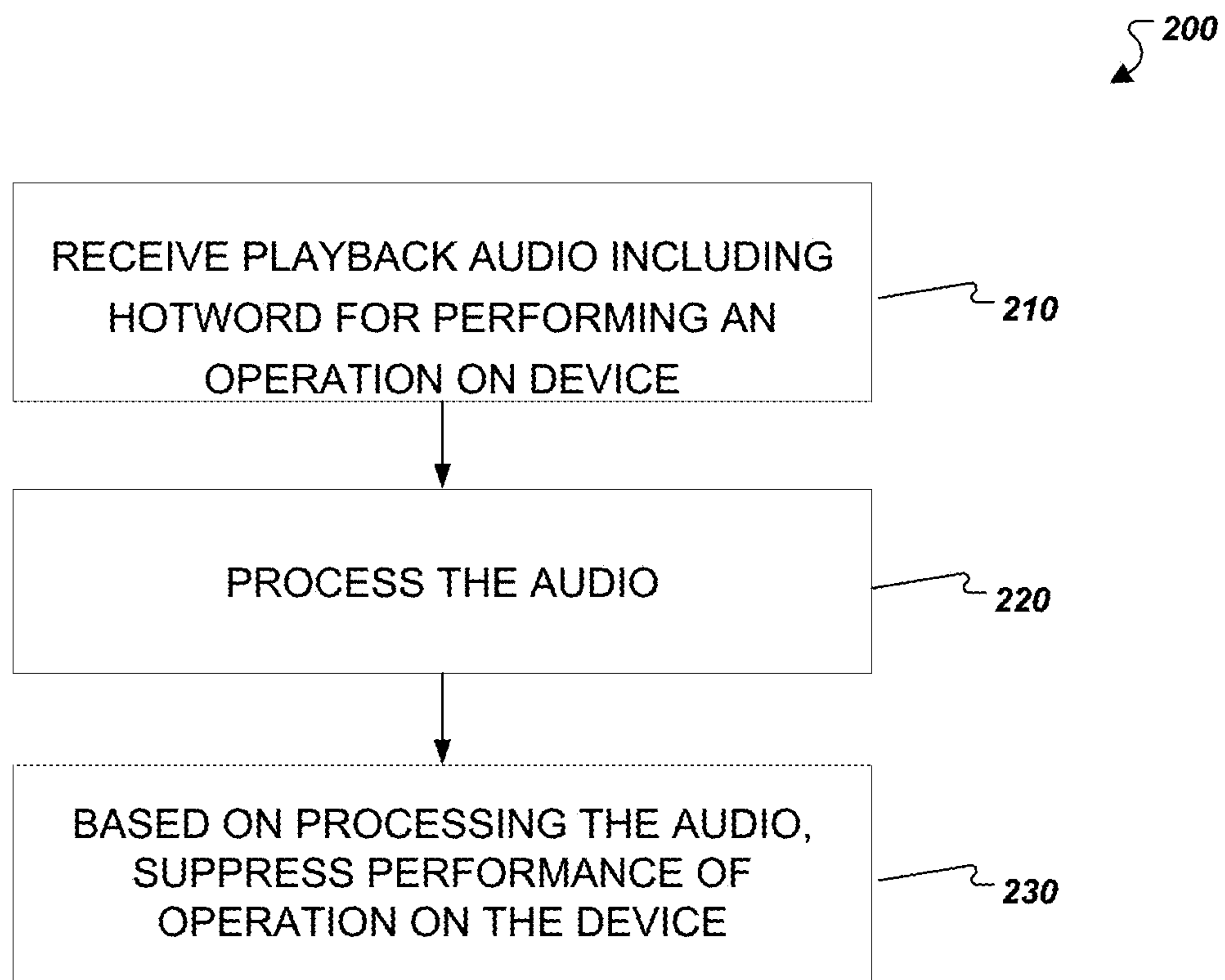

FIG. 2

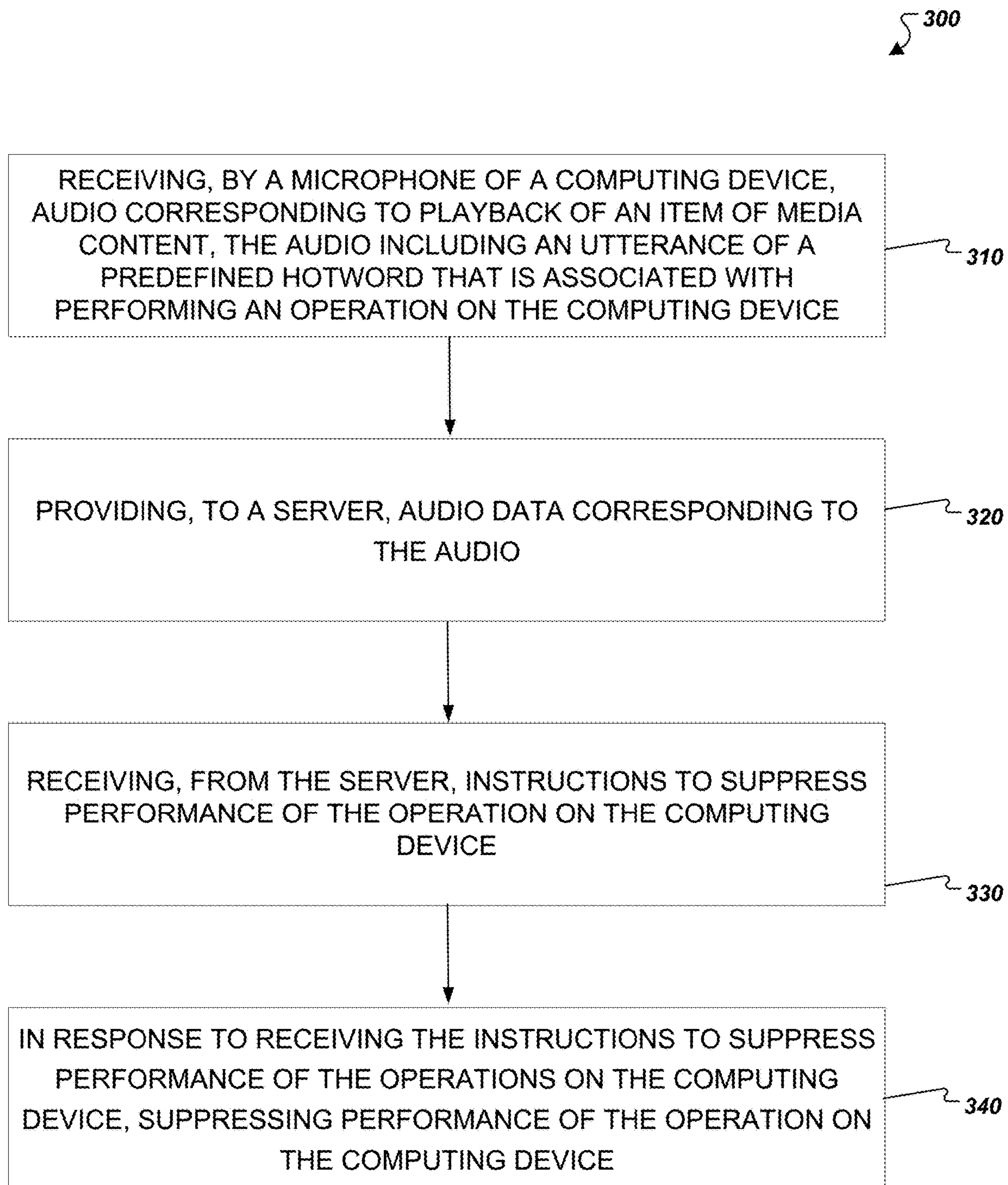

FIG. 3



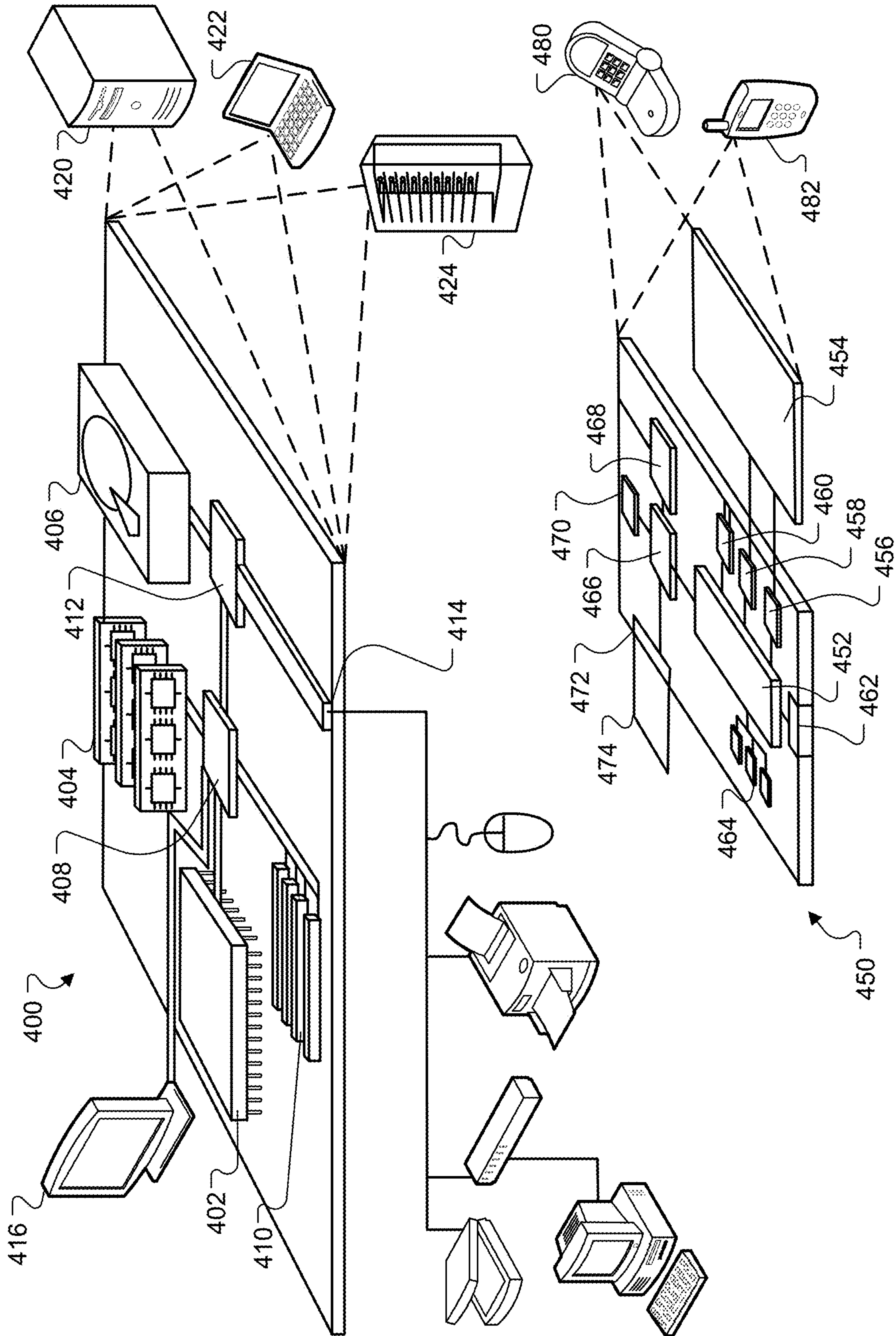

FIG. 4



## RECORDED MEDIA HOTWORD TRIGGER SUPPRESSION

### CROSS-REFERENCE TO RELATED APPLICATIONS

This application is a continuation of, and claims priority under 35 U.S.C. § 120 from, U.S. patent application Ser. No. 15/799,501, filed on Oct. 31, 2017, which claims priority under 35 U.S.C. § 119(e) to U.S. Provisional Application No. 62/497,044, filed on Nov. 7, 2016. The disclosures of these prior applications are considered part of the disclosure of this application and are hereby incorporated by reference in their entireties.

### TECHNICAL FIELD

This specification generally relates to systems and techniques for recognizing the words that a person is speaking, otherwise referred to as speech recognition.

### BACKGROUND

The reality of a speech-enabled home or other environment—that is, one in which a user need only speak a query or command out loud and a computer-based system will field and answer the query and/or cause the command to be performed—is upon us. A speech-enabled environment (e.g., home, workplace, school, etc.) can be implemented using a network of connected microphone devices distributed throughout the various rooms or areas of the environment. Through such a network of microphones, a user has the power to orally query the system from essentially anywhere in the environment without the need to have a computer or other device in front of him/her or even nearby. In order to avoid picking up utterances made in the surrounding environment that are not directed to the system, hotwords are used. A hotword (also referred to as an “attention word” or “voice action initiation command”) is a predetermined word or term that is spoken to invoke the attention of the system. When the system detects that the user has spoken a hotword, the system enters a ready state for receiving further user commands.

### SUMMARY

In a speech-enabled system, the users’ manner of interacting with the system is designed to be primarily, if not exclusively, by means of voice input. The system, which is potentially activated when it picks up a hotword included in received audio, must have some way of discerning when the hotword is not directed by a user towards the system. For example, a commercial being broadcast on a television might contain the hotword and might subsequently trigger devices in the vicinity that are running hotword detection. The devices might then be activated and await an ensuing command or query to respond to, and/or perform an operation on the device based on the command or query following the hotword. One way to prevent this from happening is to use audio fingerprinting technology to recognize that the audio including the hotword is a part of recorded media, and to suppress the performance of the operation on the computing device.

According to one innovative aspect of the subject matter described in this specification, a computing device receives audio that includes an utterance of a predefined hotword that is associated with performing an operation on the computing

device. The computing device determines whether the audio corresponds to the playback of an item of media content. The computing device then suppresses the performance of the operation on the computing device.

5 In general, another innovative aspect of the subject matter described in this specification may be embodied in methods that include the actions of receiving audio corresponding to playback of an item of media content, the audio including an utterance of a predefined hotword that is associated with performing an operation on the computing device; process-  
10 ing the audio; in response to processing the audio, suppressing performance of the operation on the computing device.

In another aspect of the subject matter described in this specification may be embodied in methods that include the  
15 actions of receiving audio corresponding to playback of an item of media content, the audio including an utterance of a predefined hotword that is associated with performing an operation on the computing device, providing audio data corresponding to the audio; receiving instructions to sup-  
20 press performance of the operation on the computing device; and in response to receiving the instructions to suppress performance of the operations on the computing device, suppressing performance of the operation on the computing device.

25 These and other embodiments can each optionally include one or more of the following features. In certain aspects, the action of processing the audio comprises processing the audio without performing speech recognition on the audio. The actions further include providing, to one or more  
30 computing devices, an indication that performance of the operation on the computing device has been suppressed. The actions further include generating an audio fingerprint of a portion of the audio; comparing the audio fingerprint to one or more audio fingerprints; and based on comparing the  
35 audio fingerprint to the one or more audio fingerprints, determining that the audio fingerprint corresponds to at least one of the one or more audio fingerprints. The action of comparing the audio fingerprint to one or more audio fingerprints comprises providing the audio fingerprint to a  
40 computing device that stores the one or more audio fingerprints; providing, to the computing device that stores the one or more audio fingerprints, a request to compare the audio fingerprint to the one or more audio fingerprints; and receiving, from the computing device that stores the one or more  
45 audio fingerprints, comparison data based on comparing the audio fingerprint to the one or more audio fingerprints.

In some implementations, the computing device remains in a low power/sleep/inactive state while receiving the audio, processing the audio, and suppressing performance of  
50 the operation. In some implementations, while receiving the audio, providing, to a display of the computing device, data indicating that the computing device is receiving the audio. In some implementations, while receiving the audio, providing, to a display of the computing device, data indicating  
55 that the computing device is processing the audio.

In some implementations, in response to processing the audio, deactivating a display of the computing device. In other implementations, in response to processing the audio, returning the computing device to a low power/sleep/inac-  
60 tive state. In some implementations, in response to processing the audio, providing, to a display of the computing device, data indicating that the computing device suppressed performance of the operation on the computing device.

In certain aspects, the method includes providing, for  
65 output, a selectable option that, upon selection by a user, provides an instruction to the computing device to perform the operation on the computing device. In some implemen-



tations, the actions further include detecting a selection of the selectable option; and adjusting a process for processing subsequently received audio that includes an utterance of the predefined hotword.

In some implementations, processing the audio comprises processing a portion of the audio before the predefined hotword. In some implementations, processing the audio comprises processing a portion of the audio following the predefined hotword. In certain aspects, further actions include determining that the audio includes an utterance of the predefined hotword, wherein the audio is processed based on determining that the audio includes an utterance of the predefined hotword. The action of determining that the audio includes an utterance of the predefined hotword comprises determining that the audio includes an utterance of the predefined hotword comprises without performing speech recognition on the audio.

Other embodiments of this aspect include corresponding systems, apparatus, and computer programs recorded on computer storage devices, each configured to perform the operations of the methods.

Particular embodiments of the subject matter described in this specification can be implemented so as to realize one or more of the following advantages. Devices can ignore commands not directed by users at the system by detecting hotwords included in pre-recorded audio and suppressing corresponding operations on the device.

The details of one or more embodiments of the subject matter described in this specification are set forth in the accompanying drawings and the description below. Other features, aspects, and advantages of the subject matter will become apparent from the description, the drawings, and the claims.

#### BRIEF DESCRIPTION OF THE DRAWINGS

FIG. 1 is a diagram of an example system for hotword trigger suppression.

FIG. 2 is a diagram of an example process for suppressing hotword triggers from recorded media.

FIG. 3 is a diagram of an example process for suppressing hotword triggers from recorded media.

FIG. 4 shows an example of a computing device and a mobile computing device.

Like reference numbers and designations in the various drawings indicate like elements.

#### DETAILED DESCRIPTION

In speech-enabled environments, devices are continuously listening for hotwords. Each time the words “OK computer” are spoken, it is picked up by a microphone, conveyed to the system, which performs speech processing operations to determine whether the hotword was spoken and, if so, awaits an ensuing command or query. It may be desirable to suppress the response to hotwords from sources that are not likely to be the ones intended to address the device. For example, when a commercial containing the words “OK computer” is played back on a television in the vicinity of the device, it is likely that it will trigger the device to enter a ready state for receiving further commands. If a query or command follows the hotword, the device might perform an operation based on the query, even though the query is not actually addressed to the device. This is an unintended and disruptive problem. The present specification addresses the problem of hotwords within recorded

media, and suppressing reaction to the hotword within such recorded media on devices in the vicinity.

FIG. 1 is a diagram of an example system 100 for hotword suppression. The example system 100 determines if an audio input, such as audio data 104, includes a hotword 104 as a part of a pre-recorded media item, and suppresses the operation on an ensuing command in response. In general, system 100 illustrates an audio device 102 outputting audio data 104 that is detected by the microphone 108 of computing device 106. The computing device 106 stores the audio data 104 in an audio buffer 124. The computing device processes the audio data 104 using a hotworder 110 to determine if the audio data 104 includes a hotword 105. Once the hotword 105 is detected, the audio data 104 is sent to a server 116. The server 116 has an audio fingerprinter 118 that feeds the encoded audio containing the hotword 105 to a fingerprint comparer 120. The fingerprint comparer 120 contains a database 122 of audio fingerprints. If the fingerprint comparer 120 determines that the audio 104 corresponds to the playback of an item of media content, an instruction 109 may be sent to the computing device 106 to suppress the performance of the operation on the computing device.

The computing device 106 can be, for example, a desktop computer, laptop computer, a tablet computer, a wearable computer, a cellular phone, a smart phone, a music player, an e-book reader, a navigation system, a smart speaker and home assistant, or any other appropriate computing device. The audio device 102 can be any source of audio such as, for example, a television, a radio, a music player, a desktop computer, laptop computer, a tablet computer, a wearable computer, a cellular phone, or a smart phone.

When the audio device 102 outputs the audio data 104 that includes the hotword 105 “OK computer,” the computing device 106 in the vicinity of the audio device 102 detects and processes the audio data 104. The computing device detects the audio data 104 through an audio input device such as a microphone 108. The microphone 108 provides audio data 104 to a respective audio subsystem. The respective audio subsystem may buffer, filter, and digitize the audio data 104. In some implementations, the computing device 106 may also perform endpointing and speaker identification on the audio data 104. The audio subsystem may include an audio buffer 124 to store filtered and digitized audio data. The audio subsystem provides the processed audio data to a hotworder 110. The hotworder 110 compares the processed audio data to known hotword data and computes a confidence score that indicates the likelihood that the audio data 104 includes a hotword.

The hotworder 110 may extract audio features from the processed audio data such as filter bank energies or mel-frequency cepstral coefficients. The hotworder 110 may use classifying windows to process these audio features such as by using a support vector machine or a neural network. Based on the processing of the audio features, if the hotworder 110 computes a confidence score that exceeds a threshold confidence score, the audio data 104 is sent to the audio fingerprinter 118. In some implementations, the computing device 106 sends the processed audio data to the server 116 and the server 116 computes a hotword confidence score. In this instance, the server 116 includes a hotworder similar to hotworder 110. The audio data 104 sent to the audio fingerprinter 118 may include the hotword 105 and audio preceding or/and following the hotword 105. In some implementations, the audio data 104 sent to the audio fingerprinter 118 may include any portion of the audio data 104. The portion of the audio data 104 may or may not



include the hotword **105**. The portion of the audio data **104** may be an initial or ending portion of the audio data **104**. The portion of the audio data **104** may precede or follow the hotword **105** either immediately or with some audio between the portion and the hotword **105**.

After receiving the audio data **104**, the audio fingerprinter **118** extracts relevant acoustic characteristics from the audio data **104** to obtain an audio signature, a content-based compact digital signature that summarizes the audio data **104**. The audio fingerprint extracted from the audio data **104** is sent to a fingerprint comparer **120**. This audio fingerprint is compared to the one or more audio fingerprints in the fingerprint database **122** using efficient matching algorithms. The fingerprint comparer **120** may compute a match score that indicates the likelihood that the audio data **104** matches an audio fingerprint in the fingerprint database. The fingerprint database **122** may be a database of known audio recordings (e.g., music, TV programs, movies, etc.) that may contain or are associated with hotwords. For example, the audio recordings may include audio that occurs before an actor speaks a hotword in a commercial. As another example, the audio recordings may include audio that occurs after an actress speaks a hotword in a movie.

The fingerprint database **122** may contain audio fingerprints of audio files that may be stored in a table embedded in a binary format. Updates to the fingerprint database **122** may be made by updates to the computing device **106**. The fingerprint database **122** may be updated by adding commercials and other media that contain the hotword, such as hotword **105**. The user may be able to update the fingerprint database **122** with audio that has hotword triggers in it. The fingerprint database **122** might also be updated by finding and identifying spikes in trigger activity among devices and identifying the triggering media and adding the media to the fingerprint database **122**. Audio recordings that contain the hotword **105** may also be identified by using available audio transcripts of the audio recordings.

Upon determining that the audio fingerprint including the predefined hotword that is associated with performing an operation on the computing device **106** corresponds to at least one of the one or more audio fingerprints contained in the fingerprint database **122**, the server **116** sends an instruction **109** to the computing device **106** to suppress the processing of the operation associated with the hotword **105** by the computing device **106**. The fingerprint comparer **120** performs this determination by comparing the match score to a threshold match score. If the match score satisfies the threshold match score, the server **116** sends an instruction **109** to the computing device **106** to suppress the processing of the operation associated with the hotword **105** by the computing device **106**. If the match score does not satisfy the threshold match score, then the server **116** provides an instruction **109** to the computing device **106** to process the operation.

Upon sending an instruction **109** to the computing device **106** to suppress the processing of the operation associated with the hotword **105** by the computing device **106**, the system **100** may store data corresponding to the process of suppression. Storing the data about suppressed queries may be useful for further quality improvements and tracking the performance of existing systems.

The audio data **104** that is sent to the hotworder **110** and to the audio fingerprinter **118** may include the hotword **105**. In some implementations, the computing device **106** streams audio data **104** to the audio fingerprinter **118** for a predetermined amount of time after the hotword **105** was uttered. In certain implementations, endpointing may be performed

on the audio data **104** following the utterance of the hotword **105**. An endpoint may be detected by detecting the locations of a discontinuity in the audio data **104** following the hotword **105**. Once an endpoint is detected, the audio fingerprinter **118** may begin processing the received audio and the computing device **106** may cease streaming the audio data **104**.

The functions performed by the audio fingerprinter **118** or hotworder **110** or both can be performed by a server **116** or by the computing device **106**, by other individual computer systems or can be distributed across multiple computer systems.

The audio fingerprinter **118** may be a part of a separate server **116**. The computing device **106** may detect a hotword **105** in the audio data **104** and this hotword **105** may trigger the activation of the computing device **106**. Upon detecting the hotword **105**, the computing device **106** may send the audio data **104** with the hotword **105** and any additional audio data following or preceding or both following and preceding the hotword **105** to a server **116**. Once the server **116** receives the required amount of audio data **104**, the server **116** may perform the audio fingerprinting processes to determine if the audio data **104** is a part of pre-recorded media. In one aspect, the server **116** might wait until a predetermined amount of audio has been received. In another aspect, the server **116** might wait until the endpoint of the audio data **104** before processing the audio data **104**. The computing device **106** might provide an indication of the detection of a hotword **105**, and send the audio data **104** to the server **116**. The indication may be a light flashing or a sound such as a beep. The indication may remain until the computing device **106** processes the following audio or until the computing device **106** receives an instruction **109** to suppress the processing of the operation associated with the hotword **105** by the computing device **106**. In one example, a home assistant may light up or beep when the hotword **105** "OK computer" is detected. The lights might spin or flicker, to indicate that the device is waiting for the audio fingerprinter **118** to respond for a while; and then the lights might deactivate if the hotword **105** is suppressed.

The fingerprint database **122**, which may be a part of the server **116** or stored locally on the computing device **106**, may be updated with audio fingerprints very quickly and efficiently. Upon sending an instruction **109** to the computing device **106** to suppress the processing of the operation associated with the hotword **105** by the computing device **106**, the system **100** may store data on the server **116** corresponding to the process of suppression. Logging the data about suppressed queries may be useful for further quality improvements and tracking the performance of existing systems. Suppression accuracy may be evaluated from the data logs. The audio fingerprinting technology on the server **116** may be updated and improved rapidly. In some implementations, the data logs may be available to the user. For example, a user may be able to find an entry for each suppressed query on a personal web history page.

In some implementations, the fingerprint database **122** might contain data corresponding to the time of broadcast of media items. For example, the fingerprint database **122** might have commercial airing schedules. The database **122** might have information about when commercials with the particular hotword might be broadcast. This might help the system to use the information to more easily and quickly identify the hotword and perform the hotword trigger suppression.

In some implementations, the audio fingerprinter **118** may be a part of computing device **106**. The audio data **104**



including the hotword **105** is sent to the audio fingerprinter **118** in order to determine if the audio data **104** is part of a pre-recorded media item. The computing device **106** might store a predetermined amount of audio data **104** in the audio buffer **124**. Once the hotword **105** is detected, the audio fingerprinter **118** might process the audio data **104** including the hotword **105** and the data in the audio buffer **124**. For example, the computing device **106** might store 10 seconds of audio in the audio buffer **124** at all times. If a television commercial is playing on a television, when the hotword triggers, the computing device **124** might fingerprint the 10 seconds of audio data **104** from the audio buffer **124**. If the television commercials contain several seconds of audio data **104** before the first hotword **105**, then the computing device **106** already has audio to match against the commercial and may not need any more audio data following the hotword **105**. This may speed up the suppression process.

In some implementations, the audio fingerprinter **118** may compare the portion of the audio data **104** preceding the hotword **105** with the audio fingerprints in the fingerprint database **122**. In some implementations, the audio fingerprinter **118** may compare the hotword **105** with the audio fingerprints in the fingerprint database **122**. In some implementations, the audio fingerprinter **118** may compare the portion of the audio following the hotword **105** with the audio fingerprints in the fingerprint database **122**. For example, a television commercial may begin with a hotword **105**, in such a situation, the system may fingerprint the hotword **105**, along with any ensuing audio.

In some implementations, the computing device **106** may appear to be unaffected by the receipt of the audio data **104** from the audio device **102**. For example, the user **126** may be watching a commercial on the audio device **102** and may be reading text on the computing device **106** in the user's hand. When a hotword **105** is detected in the audio data **104** from the commercial the computing device **106** may receive the audio data **104**, process the audio data **104**, and suppress the performance of the operation. The entire time, the activation state of the computing device **106** may remain unaffected, allowing the user to continue reading the text. If the computing device was in a low power state, a sleep state or an inactive state, it may remain unaffected during the audio detection, the audio processing and the performance suppression of the operation.

In some implementations, the computing device **106** may provide an indication of the detection of a hotword **105**, but once the instruction is received by the computing device **106** to suppress the processing of the operation associated with the hotword **105** by the computing device **106**, the indication may be disabled. In one example, a home assistant may light up or beep when the hotword "OK computer" is detected. The lights might spin or flicker, to indicate that the computing device **106** is waiting for the audio fingerprinter **118** to respond for a while; and then the lights might deactivate go away when the hotword **105** is suppressed.

In some implementations, the computing device **106** may begin to perform speech recognition on speech following the hotword **105** until the computing device **106** receives a signal to suppress the speech recognition process. The hotworder **110** computes a hotword confidence score and if the hotword confidence score satisfies a threshold, then the computing device **106** performs speech recognition on speech following the hotword **105**. The computing device **106** may perform the speech recognition without displaying any indication of the speech recognition to the user. This may be desirable because doing so gives the user the impression that the computing device **106** is not active while

also allowing the computing device to display results based on the speech recognition to the user quicker than if the computing device **106** had waited until the computing device **106** confirmed that the audio did not correspond to playback of an item of media content. As an example, the computing device **106** computes a hotword confidence score that exceeds the confidence threshold and begins to perform speech recognition on speech following the hotword **105**. The computing device **106** sends the audio data **104** to the audio fingerprinter, which processes the audio data **104** and determines that the audio data **104** does not match any audio fingerprint in the fingerprint database **122**. The computing device **106** continues to perform speech recognition on speech following the hotword **105** and presents the results to the user. As another example, if the audio fingerprinter **118** determines that the audio data **104** matches an audio fingerprint in the fingerprint database **122** and thus corresponds to playback of an item of media content, a signal is sent to the assistant server to suppress the speech recognition operations. No data is displayed to the user, and the user is likely under the impression that the computing device **106** has remained in a "sleep" state.

In some implementations, to avoid any latency, the server **116** can send a suppress signal to the assistant server before the entire audio data is processed. For example, if the fingerprint match score exceeds a threshold match score even before the entire audio data **104** is fingerprinted, the audio fingerprinter **118** could notify the assistant server to suppress the operation on the computing device **106**.

In some implementations, an indication is provided by the computing device **106** to one or more other computing devices that performance of the operation on the computing device **106** has been suppressed. This may be a beep or a light flashing on the other computing device. In some implementations, the other computing device may display a message on the display letting the user know that an action was suppressed.

After receiving the instruction to suppress the performance of the operation on the computing device **106**, the device may notify nearby devices to not respond to the hotword. In some implementations, the computing device **106** identifies other nearby computing devices that are configured to respond to the hotword **105** by searching the local network or by using short range radio for other devices that are configured to respond to the hotword **105**. For example, computing device **106** may search the local area network for other devices that are configured to respond to the hotword **105** and identify two other computing devices.

In some implementations, the computing device **106** identifies other nearby computing devices that are configured to respond to the hotword **105** by identifying the user who is logged into each device. For example, user **126** is logged into three computing devices. Each computing device shares information that is related to the user who is logged into the computing device, such as a user identifier.

FIG. 2 is a diagram of an example process **200** for hotword detection. The process **200** may be performed by a computing device such as the computing device **106** from FIG. 1. The process **200** processes audio corresponding to playback of an item of media content, the audio including an utterance of a predefined hotword that is associated with performing an operation on the computing device and in response to processing the audio, suppresses the performance of the operation on the computing device.

The computing device **106** receives playback audio **104** including a hotword **105** for performing an operation on a device (**210**). The playback audio **104** is received from the



speaker of an audio device and a microphone of the computing device receives the audio data. As an example, a television **102** may be broadcasting a commercial with the words “OK computer” and the microphone **108** of the computing device **106** receives the audio data **104** that includes the hotword “OK computer” **105**. The audio data **104** is then processed (**220**). This may involve buffering, filtering, and digitizing the audio data **104**. A hotworder **110** compares the processed audio data to known hotword data, and determines if the audio data **104** contains a hotword **105**. The audio data **104** containing the hotword **105** audio or without the hotword **105** audio is then sent to an audio fingerprinter **118**. Based on processing the audio data **104**, performance of the operation on the computing device **106** may be suppressed (**230**).

In some implementations, the audio fingerprinting and comparing may occur on one server and the instructions may be provided to the device by another server. In some implementations, the audio fingerprinting and comparing may be performed on the computing device **106**.

In some cases, a user may want the computing device **106** to perform an operation in response to a hotword **105** even when the hotword **105** is identified as being a part of a pre-recorded media item. In such a situation, the computing device **106** might provide, for output, a selectable option which, upon selection by a user, provides an instruction to the computing device **106** to perform the operation on the computing device. This could be a message on the display of the computing device **106** asking if the operation needs to be performed. The user **126** may be able to select an option on the display or send an option through any other input device. For example, a commercial playing on a television **102** may contain the utterance “OK computer what’s the weather?” The computing device **106** may then determine that the hotword is part of a pre-recorded media item and suppresses the following command. The computing device **106** may provide an indication to the user that the command was suppressed. If the user wants the command to be processed anyway, the user can select an option on the computing device **106** instructing the device to continue to process the command. In response to detecting a selection of the selectable option, the computing device **106** may, in some instances, adjust a process for processing subsequently received audio that includes an utterance of the predefined hotword.

As another example, the computing device **106** might misidentify an utterance by a user as belonging to a pre-recorded media item. In such a situation, the system may provide the user a selectable option to cancel the suppression of the performance of the operation. In this instance, the computing device **106** may also adjust the processing for processing subsequently received audio that includes an utterance of the predefined hotword.

FIG. **3** is a diagram of an example process **300** for hotword detection. The process **300** may be performed by a computing device such as the computing device **106** from FIG. **1**. The process **300** receives, by a microphone of a computing device, audio corresponding to playback of an item of media content, the audio including an utterance of a predefined hotword that is associated with performing an operation on the computing device; provides, to a server, audio data corresponding to the audio; receives, from the server, instructions to suppress performance of the operation on the computing device; in response to receiving the instructions to suppress performance of the operations on the computing device, suppressing performance of the operation on the computing device.

The computing device **106** receives, by a microphone **108** of computing device **106**, audio **104** corresponding to playback of an item of media content, the audio **104** including an utterance of a predefined hotword **105** that is associated with performing an operation on the computing device (**310**). Similar to step **210**, the audio **104** is received from a speaker of an audio device, such as television **102**. The television **102** may broadcast an item of media content, such as a song, that includes an utterance of a predefined hotword that is associated with performing an operation on the computing device **106**. For example, the song may include the words “OK computer” **105** that is typically associated with performing an operation on the computing device **106**.

The computing device **106** provides the audio data **104** to a server **116** (**320**). The server **116** has an audio fingerprinter **118** that extracts relevant acoustic characteristics from the audio data **104** to obtain an audio signature, a content-based compact digital signature that summarizes the audio data **104**. The audio fingerprint extracted from the audio data **104** is sent to a fingerprint comparer **120**. This audio fingerprint is compared to the one or more audio fingerprints in the fingerprint database **122** using efficient matching algorithms. The fingerprint comparer **120** may compute a match score that indicates the likelihood that the audio data **104** matches an audio fingerprint in the fingerprint database. The fingerprint database **122** may be a database of known audio recordings (e.g., music, TV programs, movies, etc.) that may contain or are associated with hotwords. The fingerprint comparer **120** performs this determination by comparing the match score to a threshold match score. If the match score satisfies the threshold match score, the server **116** sends an instruction **109** to the computing device **106** to suppress the processing of the operation associated with the hotword **105** by the computing device **106**. If the match score does not satisfy the threshold match score, then the server **116** provides an instruction **109** to the computing device **106** to process the operation.

In some implementations, if the server **116** provides the instruction **109** to the computing device **106** to process the operation, the computing device **106** might provide, for output, a selectable option which, upon selection by a user, provides an instruction to the computing device **106** to perform the operation on the computing device. For instance, a commercial playing on television **102** may contain the utterance “OK computer, what time is it?” If the user wants the command to be processed anyway, the user can select an option on the computing device **106** instructing to continue to process the command. In response to detecting a selection of the selectable option, the computing device **106** may, in some instances, adjust a process for processing subsequently received audio that includes an utterance of the predefined hotword.

In some implementations, the computing device **106** may automatically process the received audio that includes an utterance of the predefined hotword, in response to receiving the instruction **109** from the server **116** instructing the computing device **106** to process the received audio. In this instance, the computing device **106** will not provide an output to the user, but will automatically process the received audio. For example, the computing device **106** may process the audio that includes the utterance “OK computer, what time is it?” In response to processing the utterance, the computing device **106** may provide a response to the utterance. In this example, the response may include an audible or visual answer displayed by the computing device that recites “The time is 2:31 PM.”



## 11

The computing device **106** receives, from the server **116**, an instruction **109** that instructs the computing device **106** to suppress performance of the operation associated with the computing device **106** (**330**). The instruction **109** may include one or more processing operations for computing device **106** to execute in order to suppress performance of the operation.

In response to receiving the instruction **109** to suppress performance of the operations on the computing device **106**, the computing device **106** suppresses performance of the operation on the computing device **106**. (**340**).

FIG. **4** shows an example of a computing device **400** and a mobile computing device **450** that can be used to implement the techniques described here. The computing device **400** is intended to represent various forms of digital computers, such as laptops, desktops, workstations, personal digital assistants, servers, blade servers, mainframes, and other appropriate computers. The mobile computing device **450** is intended to represent various forms of mobile devices, such as personal digital assistants, cellular telephones, smart-phones, and other similar computing devices. The components shown here, their connections and relationships, and their functions, are meant to be examples only, and are not meant to be limiting.

The computing device **400** includes a processor **402**, a memory **404**, a storage device **406**, a high-speed interface **408** connecting to the memory **404** and multiple high-speed expansion ports **410**, and a low-speed interface **412** connecting to a low-speed expansion port **414** and the storage device **406**. Each of the processor **402**, the memory **404**, the storage device **406**, the high-speed interface **408**, the high-speed expansion ports **410**, and the low-speed interface **412**, are interconnected using various busses, and may be mounted on a common motherboard or in other manners as appropriate. The processor **402** can process instructions for execution within the computing device **400**, including instructions stored in the memory **404** or on the storage device **406** to display graphical information for a GUI on an external input/output device, such as a display **416** coupled to the high-speed interface **408**. In other implementations, multiple processors and/or multiple buses may be used, as appropriate, along with multiple memories and types of memory. Also, multiple computing devices may be connected, with each device providing portions of the necessary operations (e.g., as a server bank, a group of blade servers, or a multi-processor system).

The memory **404** stores information within the computing device **400**. In some implementations, the memory **404** is a volatile memory unit or units. In some implementations, the memory **404** is a non-volatile memory unit or units. The memory **404** may also be another form of computer-readable medium, such as a magnetic or optical disk.

The storage device **406** is capable of providing mass storage for the computing device **400**. In some implementations, the storage device **406** may be or contain a computer-readable medium, such as a floppy disk device, a hard disk device, an optical disk device, or a tape device, a flash memory or other similar solid state memory device, or an array of devices, including devices in a storage area network or other configurations. Instructions can be stored in an information carrier. The instructions, when executed by one or more processing devices (for example, processor **402**), perform one or more methods, such as those described above. The instructions can also be stored by one or more storage devices such as computer- or machine-readable mediums (for example, the memory **404**, the storage device **406**, or memory on the processor **402**).

## 12

The high-speed interface **408** manages bandwidth-intensive operations for the computing device **400**, while the low-speed interface **412** manages lower bandwidth-intensive operations. Such allocation of functions is an example only. In some implementations, the high-speed interface **408** is coupled to the memory **404**, the display **416** (e.g., through a graphics processor or accelerator), and to the high-speed expansion ports **410**, which may accept various expansion cards (not shown). In the implementation, the low-speed interface **412** is coupled to the storage device **406** and the low-speed expansion port **414**. The low-speed expansion port **414**, which may include various communication ports (e.g., USB, Bluetooth, Ethernet, wireless Ethernet) may be coupled to one or more input/output devices, such as a keyboard, a pointing device, a scanner, or a networking device such as a switch or router, e.g., through a network adapter.

The computing device **400** may be implemented in a number of different forms, as shown in the figure. For example, it may be implemented as a standard server **420**, or multiple times in a group of such servers. In addition, it may be implemented in a personal computer such as a laptop computer **422**. It may also be implemented as part of a rack server system **424**. Alternatively, components from the computing device **400** may be combined with other components in a mobile device (not shown), such as a mobile computing device **450**. Each of such devices may contain one or more of the computing device **400** and the mobile computing device **450**, and an entire system may be made up of multiple computing devices communicating with each other.

The mobile computing device **450** includes a processor **452**, a memory **464**, an input/output device such as a display **454**, a communication interface **466**, and a transceiver **468**, among other components. The mobile computing device **450** may also be provided with a storage device, such as a micro-drive or other device, to provide additional storage. Each of the processor **452**, the memory **464**, the display **454**, the communication interface **466**, and the transceiver **468**, are interconnected using various buses, and several of the components may be mounted on a common motherboard or in other manners as appropriate.

The processor **452** can execute instructions within the mobile computing device **450**, including instructions stored in the memory **464**. The processor **452** may be implemented as a chipset of chips that include separate and multiple analog and digital processors. The processor **452** may provide, for example, for coordination of the other components of the mobile computing device **450**, such as control of user interfaces, applications run by the mobile computing device **450**, and wireless communication by the mobile computing device **450**.

The processor **452** may communicate with a user through a control interface **458** and a display interface **456** coupled to the display **454**. The display **454** may be, for example, a TFT (Thin-Film-Transistor Liquid Crystal Display) display or an OLED (Organic Light Emitting Diode) display, or other appropriate display technology. The display interface **456** may comprise appropriate circuitry for driving the display **454** to present graphical and other information to a user. The control interface **458** may receive commands from a user and convert them for submission to the processor **452**. In addition, an external interface **462** may provide communication with the processor **452**, so as to enable near area communication of the mobile computing device **450** with other devices. The external interface **462** may provide, for example, for wired communication in some implementa-



tions, or for wireless communication in other implementations, and multiple interfaces may also be used.

The memory **464** stores information within the mobile computing device **450**. The memory **464** can be implemented as one or more of a computer-readable medium or media, a volatile memory unit or units, or a non-volatile memory unit or units. An expansion memory **474** may also be provided and connected to the mobile computing device **450** through an expansion interface **472**, which may include, for example, a SIMM (Single In Line Memory Module) card interface. The expansion memory **474** may provide extra storage space for the mobile computing device **450**, or may also store applications or other information for the mobile computing device **450**. Specifically, the expansion memory **474** may include instructions to carry out or supplement the processes described above, and may include secure information also. Thus, for example, the expansion memory **474** may be provide as a security module for the mobile computing device **450**, and may be programmed with instructions that permit secure use of the mobile computing device **450**. In addition, secure applications may be provided via the SIMM cards, along with additional information, such as placing identifying information on the SIMM card in a non-hackable manner.

The memory may include, for example, flash memory and/or NVRAM memory (non-volatile random access memory), as discussed below. In some implementations, instructions are stored in an information carrier such that the instructions, when executed by one or more processing devices (for example, processor **452**), perform one or more methods, such as those described above. The instructions can also be stored by one or more storage devices, such as one or more computer- or machine-readable mediums (for example, the memory **464**, the expansion memory **474**, or memory on the processor **452**). In some implementations, the instructions can be received in a propagated signal, for example, over the transceiver **468** or the external interface **462**.

The mobile computing device **450** may communicate wirelessly through the communication interface **466**, which may include digital signal processing circuitry where necessary. The communication interface **466** may provide for communications under various modes or protocols, such as GSM voice calls (Global System for Mobile communications), SMS (Short Message Service), EMS (Enhanced Messaging Service), or MMS messaging (Multimedia Messaging Service), CDMA (code division multiple access), TDMA (time division multiple access), PDC (Personal Digital Cellular), WCDMA (Wideband Code Division Multiple Access), CDMA2000, or GPRS (General Packet Radio Service), among others. Such communication may occur, for example, through the transceiver **368** using a radio-frequency. In addition, short-range communication may occur, such as using a Bluetooth, WiFi, or other such transceiver (not shown). In addition, a GPS (Global Positioning System) receiver module **470** may provide additional navigation- and location-related wireless data to the mobile computing device **450**, which may be used as appropriate by applications running on the mobile computing device **450**.

The mobile computing device **450** may also communicate audibly using an audio codec **460**, which may receive spoken information from a user and convert it to usable digital information. The audio codec **460** may likewise generate audible sound for a user, such as through a speaker, e.g., in a handset of the mobile computing device **450**. Such sound may include sound from voice telephone calls, may include recorded sound (e.g., voice messages, music files,

etc.) and may also include sound generated by applications operating on the mobile computing device **450**.

The mobile computing device **450** may be implemented in a number of different forms, as shown in the figure. For example, it may be implemented as a cellular telephone **480**. It may also be implemented as part of a smart-phone **482**, personal digital assistant, or other similar mobile device.

Various implementations of the systems and techniques described here can be realized in digital electronic circuitry, integrated circuitry, specially designed ASICs (application specific integrated circuits), computer hardware, firmware, software, and/or combinations thereof. These various implementations can include implementation in one or more computer programs that are executable and/or interpretable on a programmable system including at least one programmable processor, which may be special or general purpose, coupled to receive data and instructions from, and to transmit data and instructions to, a storage system, at least one input device, and at least one output device.

These computer programs (also known as programs, software, software applications or code) include machine instructions for a programmable processor, and can be implemented in a high-level procedural and/or object-oriented programming language, and/or in assembly/machine language. As used herein, the terms machine-readable medium and computer-readable medium refer to any computer program product, apparatus and/or device (e.g., magnetic discs, optical disks, memory, Programmable Logic Devices (PLDs)) used to provide machine instructions and/or data to a programmable processor, including a machine-readable medium that receives machine instructions as a machine-readable signal. The term machine-readable signal refers to any signal used to provide machine instructions and/or data to a programmable processor.

To provide for interaction with a user, the systems and techniques described here can be implemented on a computer having a display device (e.g., a CRT (cathode ray tube) or LCD (liquid crystal display) monitor) for displaying information to the user and a keyboard and a pointing device (e.g., a mouse or a trackball) by which the user can provide input to the computer. Other kinds of devices can be used to provide for interaction with a user as well; for example, feedback provided to the user can be any form of sensory feedback (e.g., visual feedback, auditory feedback, or tactile feedback); and input from the user can be received in any form, including acoustic, speech, or tactile input.

The systems and techniques described here can be implemented in a computing system that includes a back end component (e.g., as a data server), or that includes a middleware component (e.g., an application server), or that includes a front end component (e.g., a client computer having a graphical user interface or a Web browser through which a user can interact with an implementation of the systems and techniques described here), or any combination of such back end, middleware, or front end components. The components of the system can be interconnected by any form or medium of digital data communication (e.g., a communication network). Examples of communication networks include a local area network (LAN), a wide area network (WAN), and the Internet.

The computing system can include clients and servers. A client and server are generally remote from each other and typically interact through a communication network. The relationship of client and server arises by virtue of computer programs running on the respective computers and having a client-server relationship to each other.



Although a few implementations have been described in detail above, other modifications are possible. For example, while a client application is described as accessing the delegate(s), in other implementations the delegate(s) may be employed by other applications implemented by one or more processors, such as an application executing on one or more servers. In addition, the logic flows depicted in the figures do not require the particular order shown, or sequential order, to achieve desirable results. In addition, other actions may be provided, or actions may be eliminated, from the described flows, and other components may be added to, or removed from, the described systems. Accordingly, other implementations are within the scope of the following claims.

What is claimed is:

1. A method comprising:
  - receiving, at a computing device, audio data corresponding to playback of an item of media content, the audio data captured by a microphone of the computing device;
  - detecting, by the computing device, an utterance of a predefined hotword in the audio data;
  - in response to detecting the utterance of the predefined hotword:
    - initiating, by the computing device, performance of speech recognition on speech following the utterance of the predefined hotword in the audio data;
    - generating, by the data processing hardware, an audio fingerprint of the audio data; and
    - determining, by the data processing hardware, that the audio fingerprint corresponds to a stored audio fingerprint, the stored audio fingerprint associated with a known audio recording that contains or is associated with the predefined hotword; and
  - in response to determining that the audio fingerprint corresponds to the stored audio fingerprint:
    - ceasing, by the computing device, the performance of speech recognition on the speech following the utterance of the predefined hotword in the audio data; and
    - sending, by the computing device, to each of one or more nearby computing devices configured to respond to the predefined hotword, a notification instructing each of the one or more nearby computing devices to not respond to the utterance of the predefined hotword in the audio data.
2. The method of claim 1, further comprising:
  - in response to detecting the utterance of the predefined hotword, activating, by the computing device, a display of the computing device to display data indicating that performance of speech recognition on the speech is in progress; and
  - in response to determining that the audio fingerprint corresponds to the stored audio fingerprint, deactivating, by the computing device, the display of the computing device.
3. The method of claim 1, further comprising:
  - in response to detecting the utterance of the predefined hotword, activating, by the computing device, a light on the computing device to flash while speech recognition is performed on the speech; and
  - in response to determining that the audio fingerprint corresponds to the stored audio fingerprint, deactivating, by the computing device, the light on the computing device.
4. The method of claim 1, further comprising, in response to detecting the utterance of the predefined hotword, providing, by the computing device, an audible alert from the

computing device to indicate that performance of speech recognition on the speech is in progress.

5. The method of claim 1, wherein the computing device is in a low power/sleep/inactive state while:

- receiving the audio data;
- detecting the utterance of the predefined hotword;
- initiating the performance of speech recognition;
- generating the audio fingerprint;
- determining that the audio fingerprint corresponds to the stored audio fingerprint;
- ceasing the performance of speech recognition; and
- sending the notification.

6. The method of claim 1, wherein detecting the utterance of the predefined hotword in the audio data comprises detecting the utterance of the predefined hotword without performing speech recognition on the audio data.

7. The method of claim 1, wherein determining that the audio fingerprint corresponds to the stored fingerprint comprises:

- providing the audio fingerprint to another computing device that stores the stored audio fingerprint;
- providing, to the other computing device that stores the stored audio fingerprint, a request to compare the audio fingerprint to the stored audio fingerprint; and
- receiving, from the other computing device, comparison data indicating that the audio fingerprint corresponds to the stored fingerprint.

8. The method of claim 1, wherein initiating performance of speech recognition on the speech following the utterance of the predefined hotword in the audio data comprises initiating performance of speech recognition on the speech without displaying any indication of the speech recognition.

9. The method of claim 1, further comprising, in response to determining that the audio fingerprint corresponds to the stored audio fingerprint:

- searching, by the computing device, a local network for other computing devices configured to respond to the predefined hotword; and
- identifying, by the computing device, each of one or more nearby computing devices configured to respond to the predefined hotword based on searching the local network.

10. The method of claim 1, further comprising, in response to determining that the audio fingerprint corresponds to the stored audio fingerprint, providing, by the computing device, a selectable option to enable a user of the computing device to cancel the ceasing of the performance of the speech recognition on the speech.

11. A computing device comprising:

- data processing hardware; and
- memory hardware in communication with the data processing hardware and storing instructions that when executed by the data processing hardware cause the data processing hardware to perform operations comprising:
  - receiving audio data corresponding to playback of an item of media content, the audio data captured by a microphone of the computing device;
  - detecting an utterance of a predefined hotword in the audio data;
  - in response to detecting the utterance of the predefined hotword:
    - initiating performance of speech recognition on speech following the utterance of the predefined hotword in the audio data;
    - generating an audio fingerprint of the audio data; and



17

determining that the audio fingerprint corresponds to a stored audio fingerprint, the stored audio fingerprint associated with a known audio recording that contains or is associated with the predefined hotword; and

in response to determining that the audio fingerprint corresponds to the stored audio fingerprint:

ceasing the performance of speech recognition on the speech following the utterance of the predefined hotword in the audio data; and

sending, to each of one or more nearby computing devices configured to respond to the predefined hotword, a notification instructing each of the one or more nearby computing devices to not respond to the utterance of the predefined hotword in the audio data.

12. The computing device of claim 11, wherein the operations further comprise:

in response to detecting the utterance of the predefined hotword, activating a display of the computing device to display data indicating that performance of speech recognition on the speech is in progress; and

in response to determining that the audio fingerprint corresponds to the stored audio fingerprint, deactivating the display of the computing device.

13. The computing device of claim 11, wherein the operations further comprise:

in response to detecting the utterance of the predefined hotword, activating a light on the computing device to flash while speech recognition is performed on the speech; and

in response to determining that the audio fingerprint corresponds to the stored audio fingerprint, deactivating the light on the computing device.

14. The computing device of claim 11, wherein the operations further comprise, in response to detecting the utterance of the predefined hotword, providing an audible alert from the computing device to indicate that performance of speech recognition on the speech is in progress.

15. The computing device of claim 11, wherein the computing device is in a low power/sleep/inactive state while:

receiving the audio data;

detecting the utterance of the predefined hotword;

18

initiating the performance of speech recognition;

generating the audio fingerprint;

determining that the audio fingerprint corresponds to the stored audio fingerprint;

ceasing the performance of speech recognition; and  
sending the notification.

16. The computing device of claim 11, wherein detecting the utterance of the predefined hotword in the audio data comprises detecting the utterance of the predefined hotword without performing speech recognition on the audio data.

17. The computing device of claim 11, wherein determining that the audio fingerprint corresponds to the stored fingerprint comprises:

providing the audio fingerprint to another computing device that stores the stored audio fingerprint;

providing, to the other computing device that stores the stored audio fingerprint, a request to compare the audio fingerprint to the stored audio fingerprint; and

receiving, from the other computing device, comparison data indicating that the audio fingerprint corresponds to the stored fingerprint.

18. The computing device of claim 11, wherein initiating performance of speech recognition on the speech following the utterance of the predefined hotword in the audio data comprises initiating performance of speech recognition on the speech without displaying any indication of the speech recognition.

19. The computing device of claim 11, wherein the operations further comprise, in response to determining that the audio fingerprint corresponds to the stored audio fingerprint:

searching a local network for other computing devices configured to respond to the predefined hotword; and

identifying each of one or more nearby computing devices configured to respond to the predefined hotword based on searching the local network.

20. The computing device of claim 11, wherein the operations further comprise, in response to determining that the audio fingerprint corresponds to the stored audio fingerprint, providing, a selectable option to enable a user of the computing device to cancel the ceasing of the performance of the speech recognition on the speech.

\* \* \* \* \*