



US011223437B1

(12) **United States Patent**  
**Evans et al.**

(10) **Patent No.:** **US 11,223,437 B1**  
(45) **Date of Patent:** **Jan. 11, 2022**

(54) **DIFFERENTIAL CLOCK RECOVERY USING A GLOBAL REFERENCE TIME**

(71) Applicant: **Ciena Corporation**, Hanover, MD (US)

(72) Inventors: **David James Evans**, Ottawa (CA);  
**John Andrew Earl**, Ottawa (CA);  
**Daniel Claude Perras**, Ottawa (CA)

(73) Assignee: **Ciena Corporation**, Hanover, MD (US)

(\*) Notice: Subject to any disclaimer, the term of this patent is extended or adjusted under 35 U.S.C. 154(b) by 0 days.

(21) Appl. No.: **17/001,204**

(22) Filed: **Aug. 24, 2020**

(51) **Int. Cl.**  
**H04J 3/06** (2006.01)

(52) **U.S. Cl.**  
CPC ..... **H04J 3/0641** (2013.01); **H04J 3/0661** (2013.01); **H04J 3/0673** (2013.01); **H04J 3/0697** (2013.01)

(58) **Field of Classification Search**  
None  
See application file for complete search history.

(56) **References Cited**

U.S. PATENT DOCUMENTS

7,333,508	B2	2/2008	Rabie et al.	
7,406,088	B2	7/2008	Magd et al.	
7,417,995	B2	8/2008	Rabie et al.	
7,505,466	B2	3/2009	Rabie et al.	
7,565,436	B2	7/2009	Rabie et al.	
7,613,212	B1 *	11/2009	Raz	H04J 3/0641 370/510
8,018,841	B2	9/2011	Holness et al.	
8,149,692	B2	4/2012	Holness et al.	

8,305,938	B2	11/2012	Holness et al.	
8,687,633	B2	4/2014	Rabie et al.	
9,401,817	B2	7/2016	Holness et al.	
10,256,909	B2	4/2019	Gareau et al.	
10,313,103	B1	6/2019	Perras et al.	
10,396,972	B1	8/2019	Gareau et al.	
10,594,423	B1 *	3/2020	Anand	H04L 69/22
2005/0013394	A1 *	1/2005	Rausch	H04J 3/0652 375/356
2005/0141509	A1	6/2005	Rabie et al.	
2007/0217343	A1 *	9/2007	Znamova	H04L 41/00 370/252
2010/0098433	A1 *	4/2010	Boyd	H04J 3/0658 398/155
2011/0035511	A1 *	2/2011	Biederman	H04J 3/0667 709/248
2012/0027146	A1 *	2/2012	Hodge	H04J 3/0664 375/356

(Continued)

FOREIGN PATENT DOCUMENTS

EP	1712035	A1	10/2006
EP	2460320	A4	6/2013

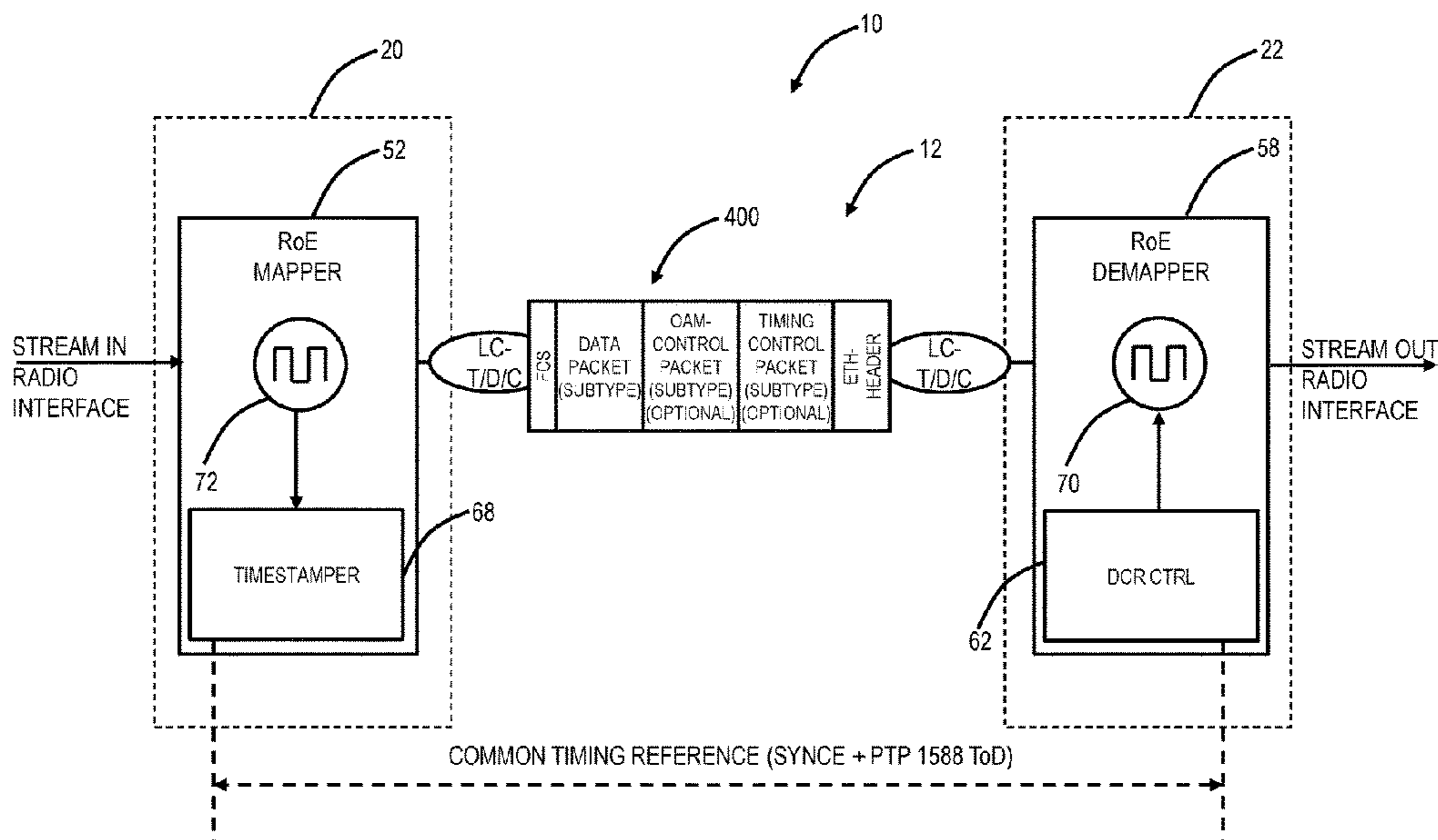
(Continued)

*Primary Examiner* — Kodzovi Acolatse  
(74) *Attorney, Agent, or Firm* — Clements Bernard Baratta; Lawrence A. Baratta, Jr.; Christopher L. Bernard

(57) **ABSTRACT**

A method, at an egress node, includes synchronizing with a global reference time; receiving a signal including a presentation time for when a specific part of the signal is to be transmitted, wherein the presentation time was determined by the ingress node with reference to the global reference time; determining an actual transmission time when the specific part of the signal is transmitted; and causing adjustment of a clock based on a time error derived from a difference between the presentation time and the actual transmission time.

**13 Claims, 11 Drawing Sheets**



(56)

**References Cited**

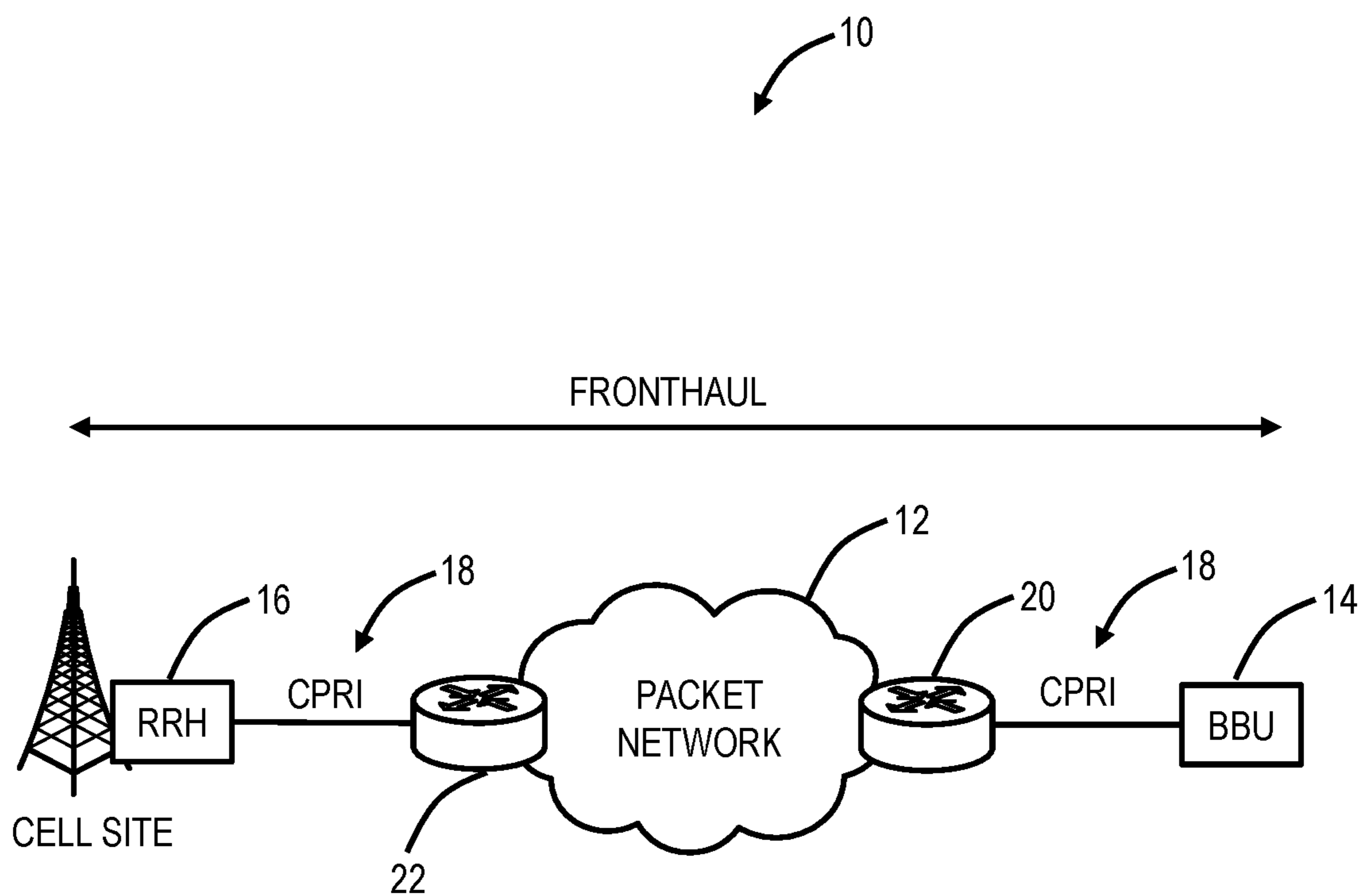
U.S. PATENT DOCUMENTS

2013/0301634 A1\* 11/2013 Ehlers ..... H04L 12/4625  
370/350  
2015/0312766 A1\* 10/2015 Teeni ..... H04W 24/02  
455/411  
2016/0080110 A1\* 3/2016 Gareau ..... H04L 1/0045  
398/66  
2016/0374041 A1\* 12/2016 Zhang ..... H04W 56/0015  
2017/0214516 A1 7/2017 Rivaud et al.  
2019/0097744 A1 3/2019 Abdullah et al.  
2019/0141056 A1 5/2019 Estabrooks et al.  
2020/0028585 A1 1/2020 Abdullah et al.  
2020/0344333 A1\* 10/2020 Hawari ..... H04L 49/9078  
2021/0051494 A1\* 2/2021 Anand ..... H04L 41/069  
2021/0234625 A1\* 7/2021 Mok ..... H04J 3/0658  
2021/0242898 A1\* 8/2021 Shpak ..... H04L 61/6022  
2021/0304167 A1\* 9/2021 Kahn ..... G06Q 20/1235  
2021/0336864 A1\* 10/2021 Ruffini ..... H04L 43/0852

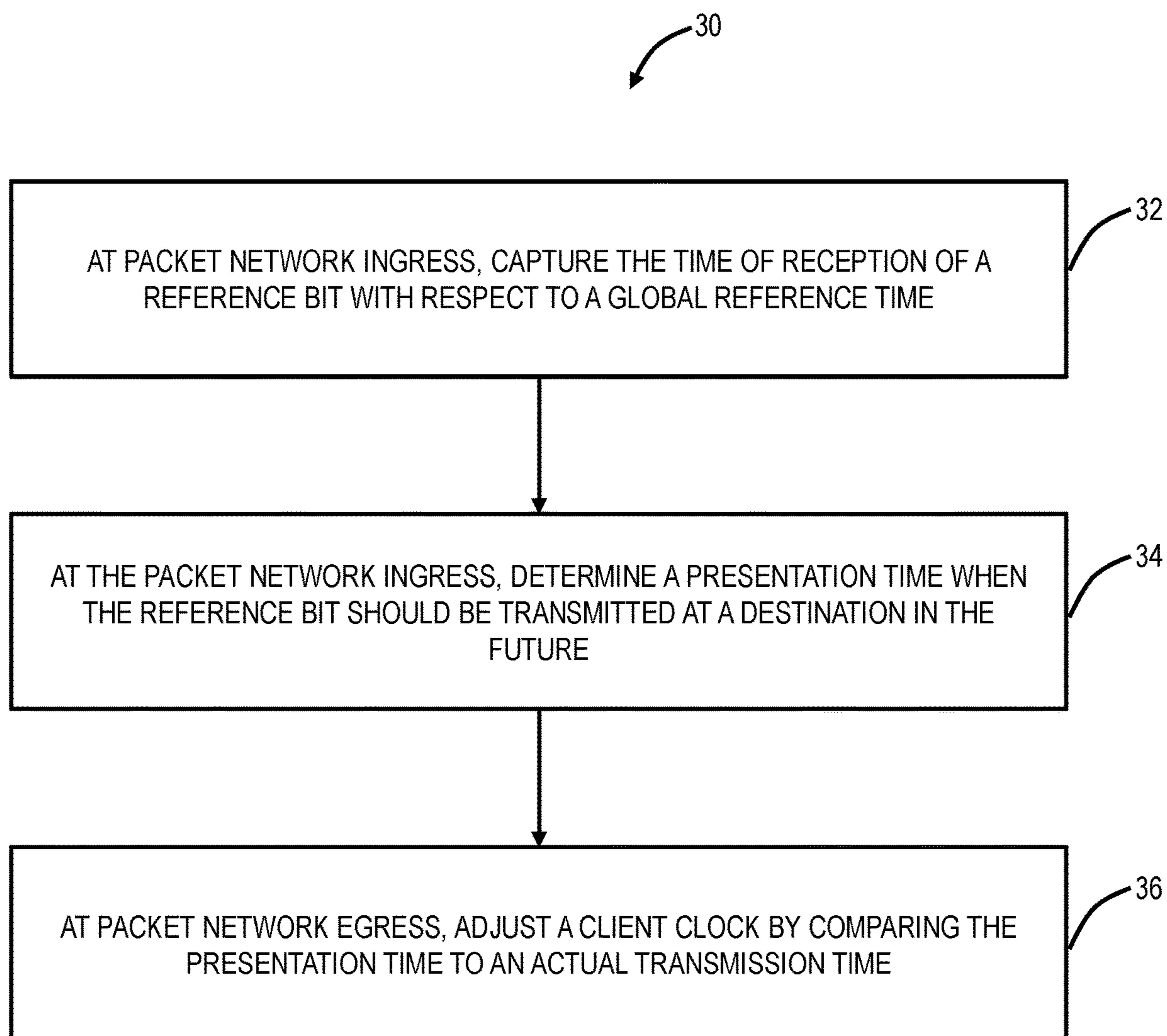
FOREIGN PATENT DOCUMENTS

EP 2996270 A1 3/2016  
EP 2417735 B1 6/2017  
EP 2430798 B1 8/2018  
WO 2020112260 A1 6/2020

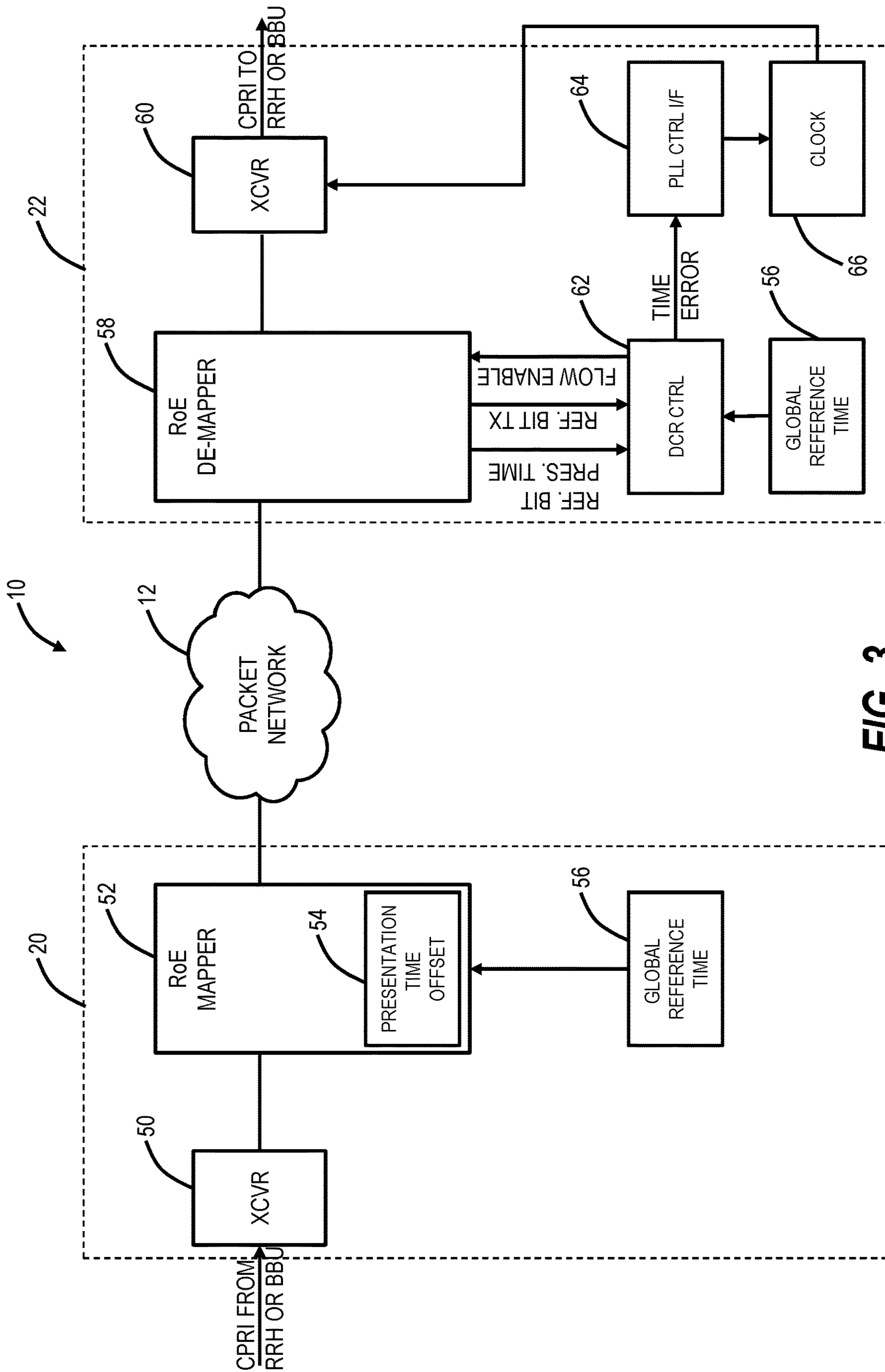
\* cited by examiner



**FIG. 1**

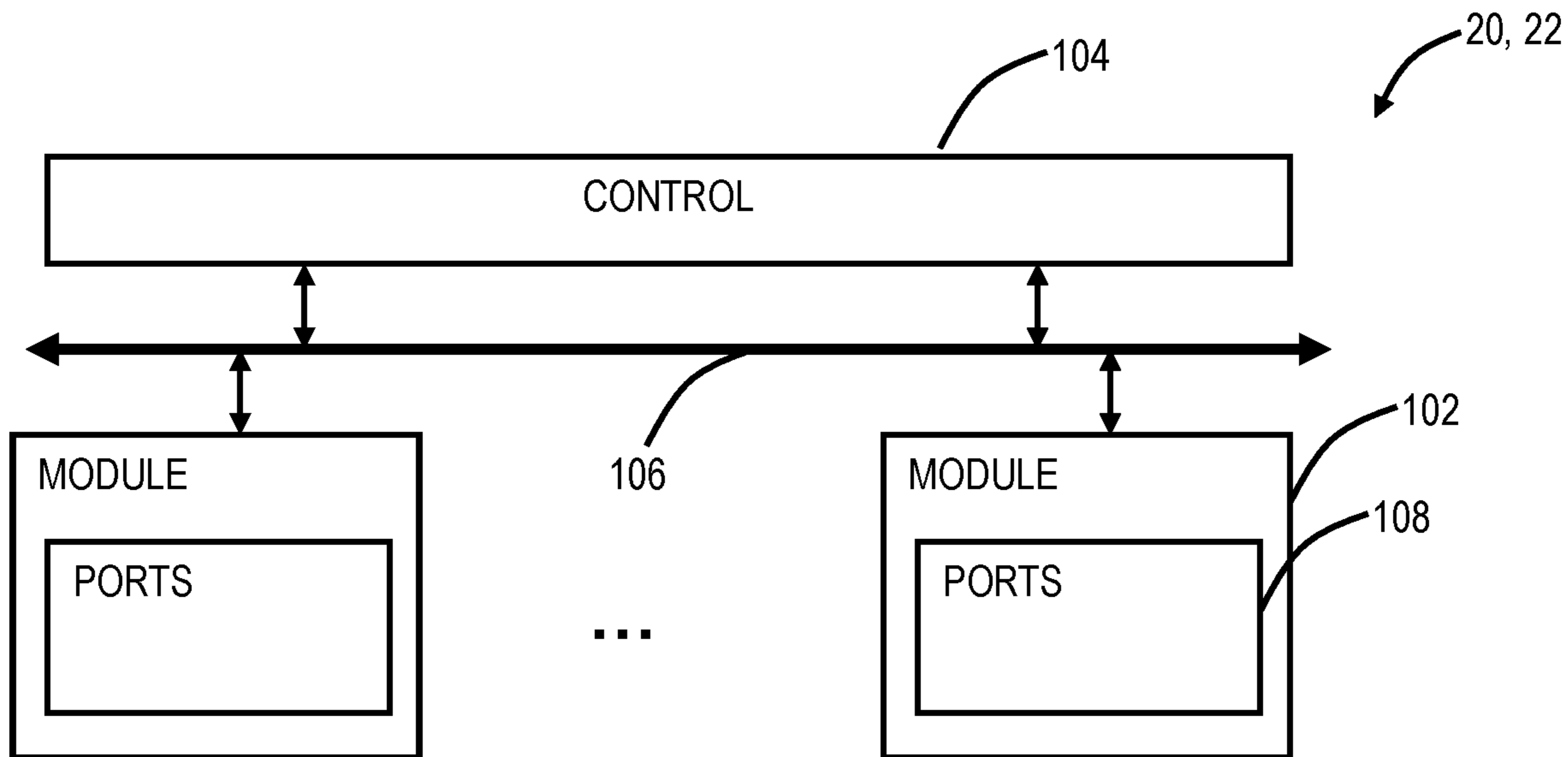


**FIG. 2**

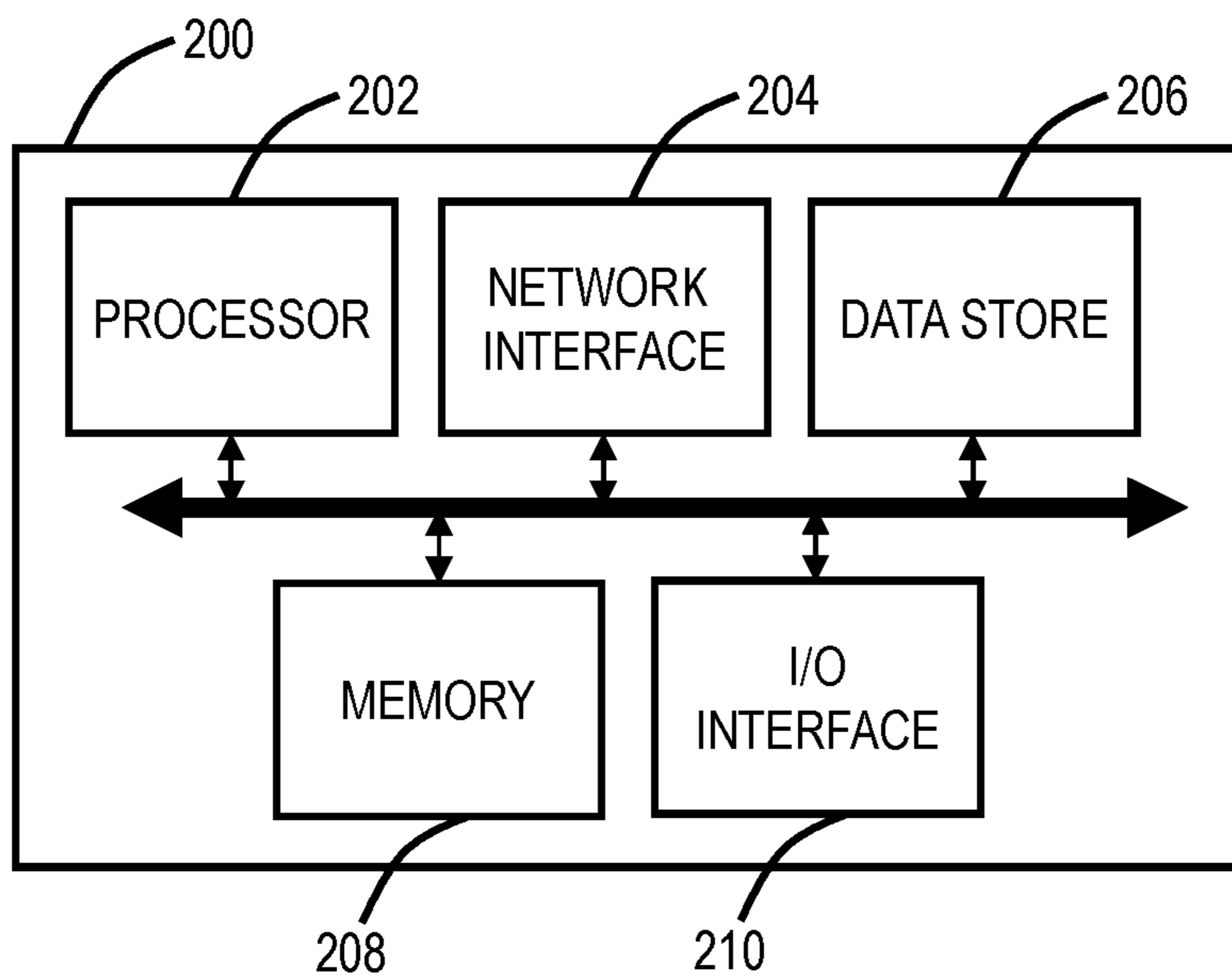


**FIG. 3**

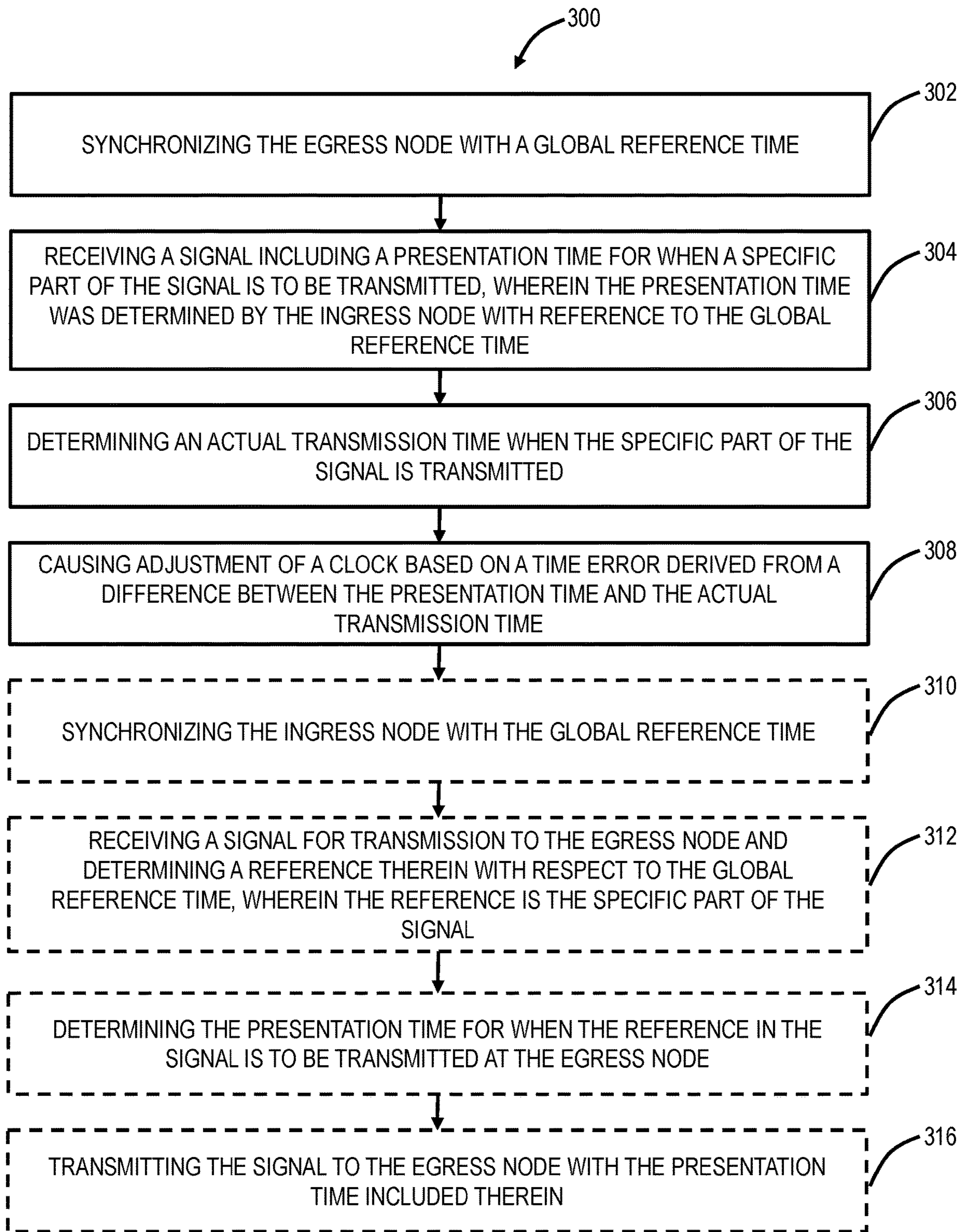




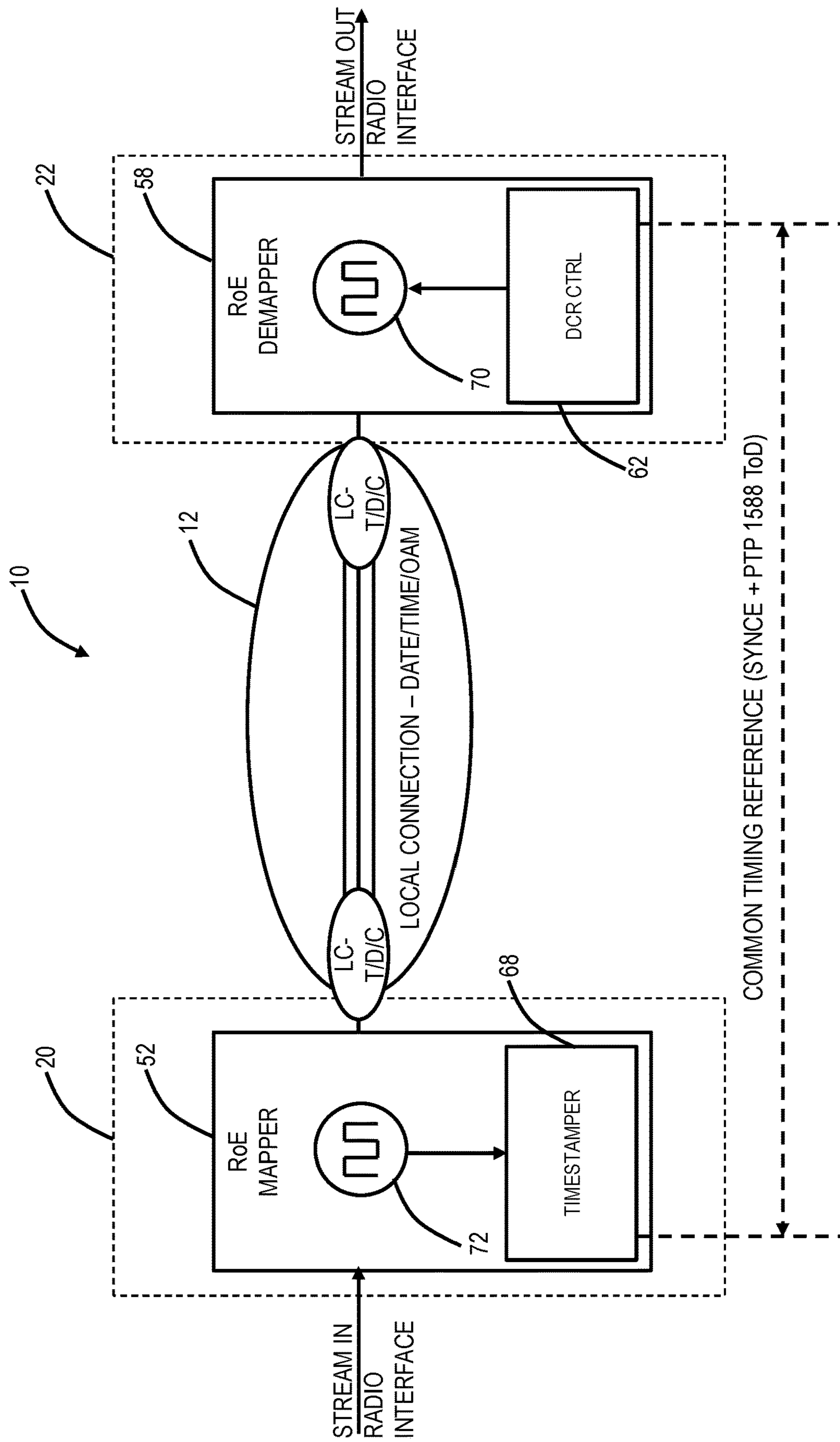
**FIG. 4**



**FIG. 5**

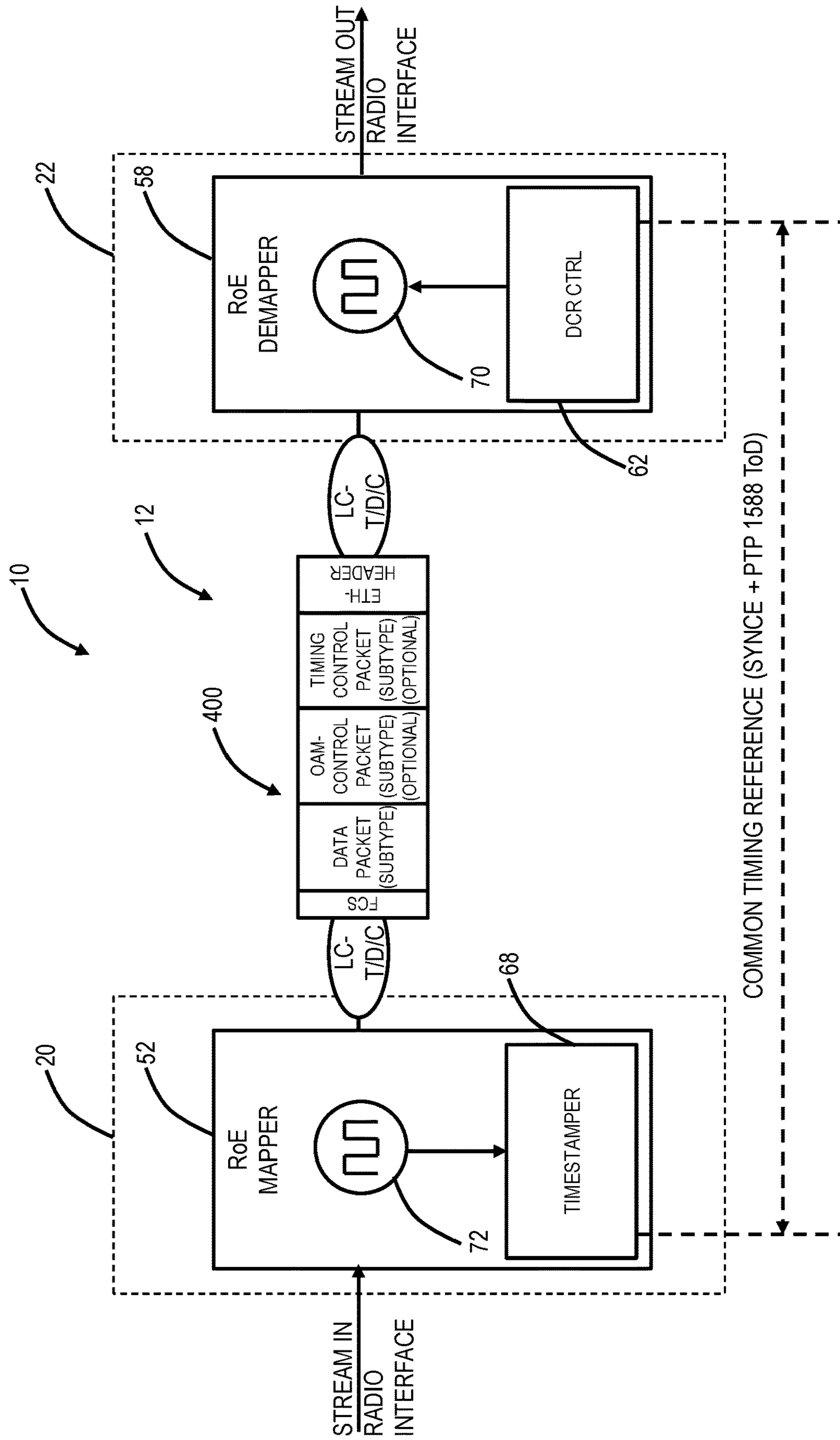


**FIG. 6**

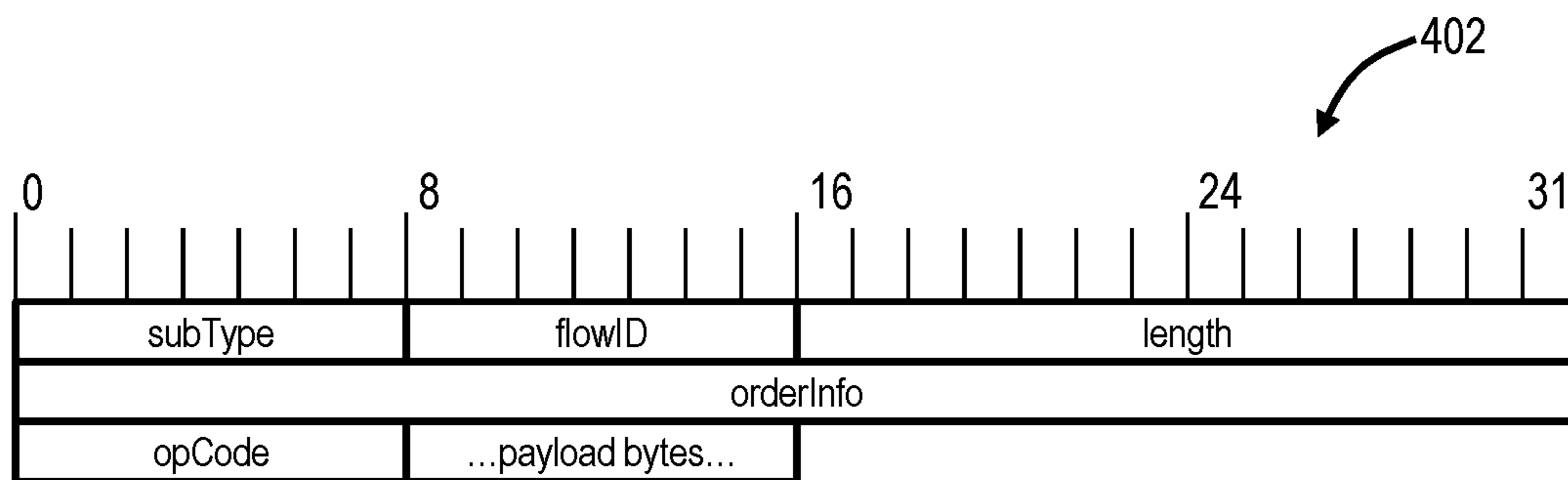


**FIG. 7**

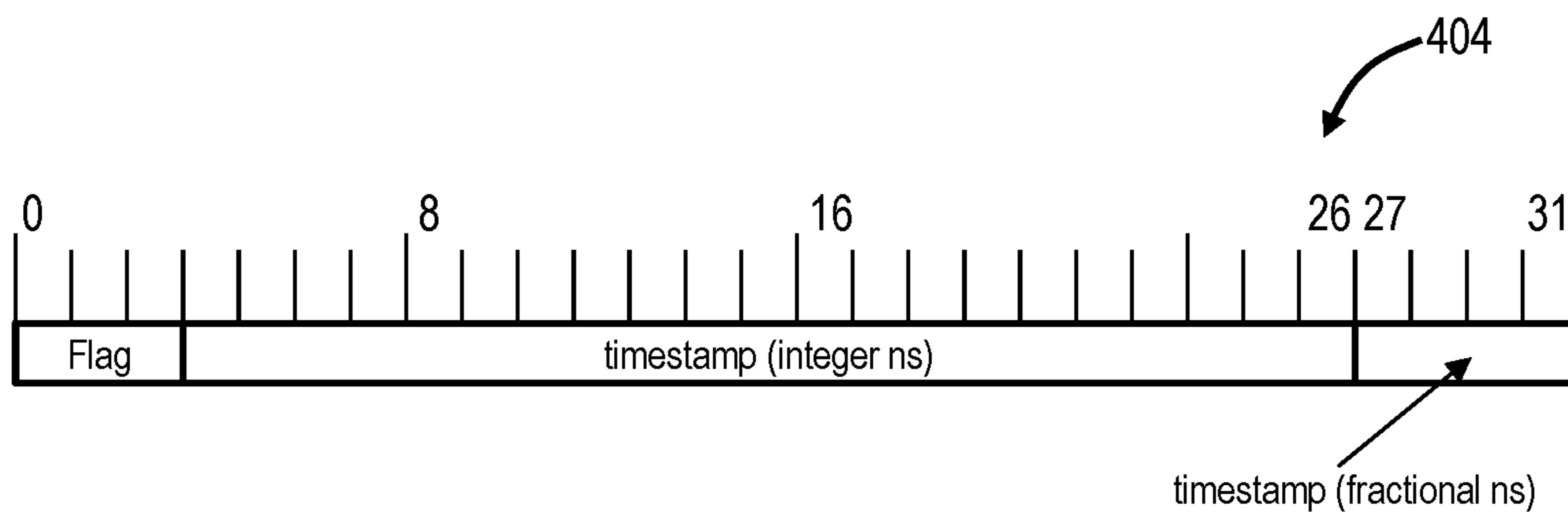




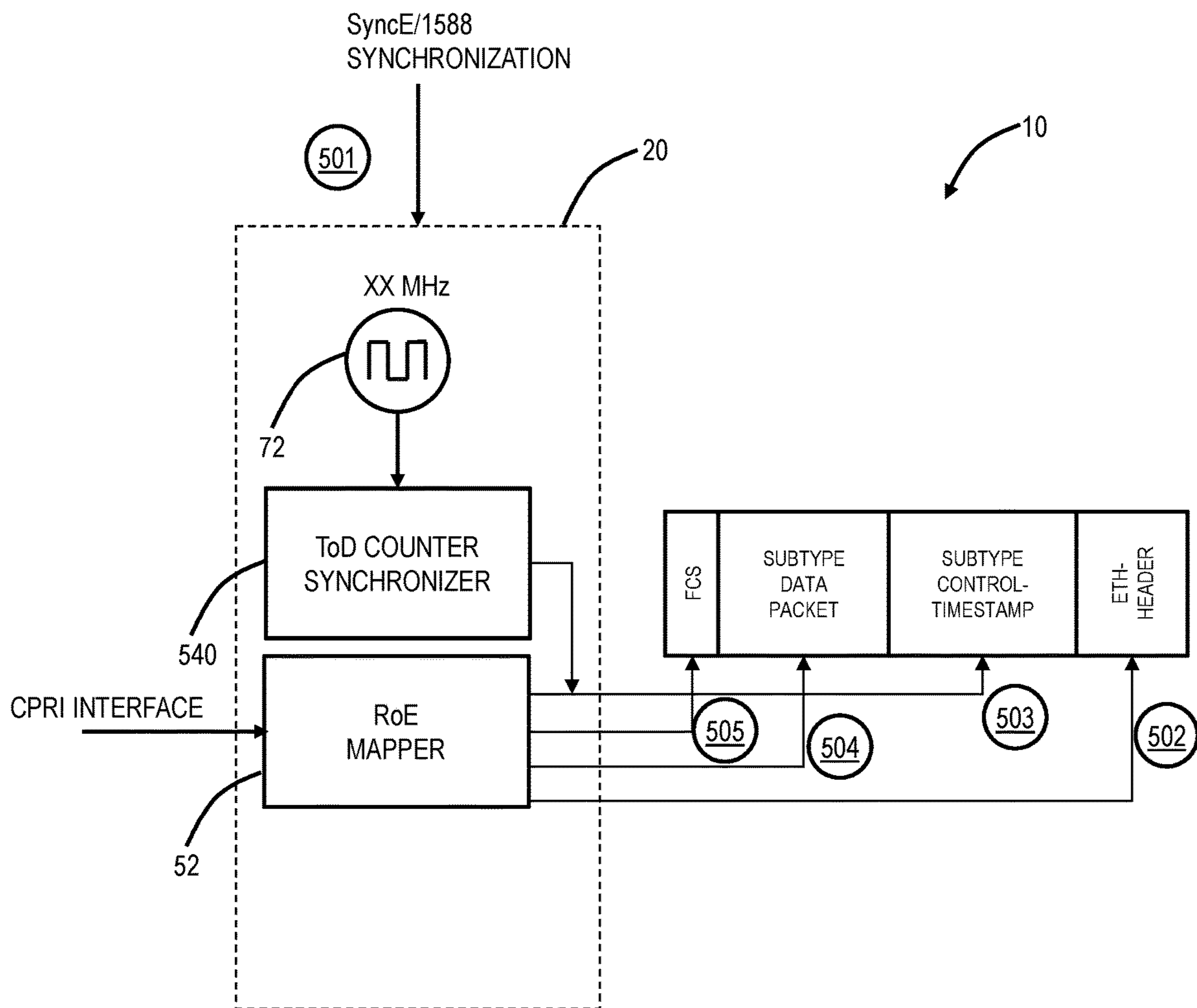
**FIG. 8**



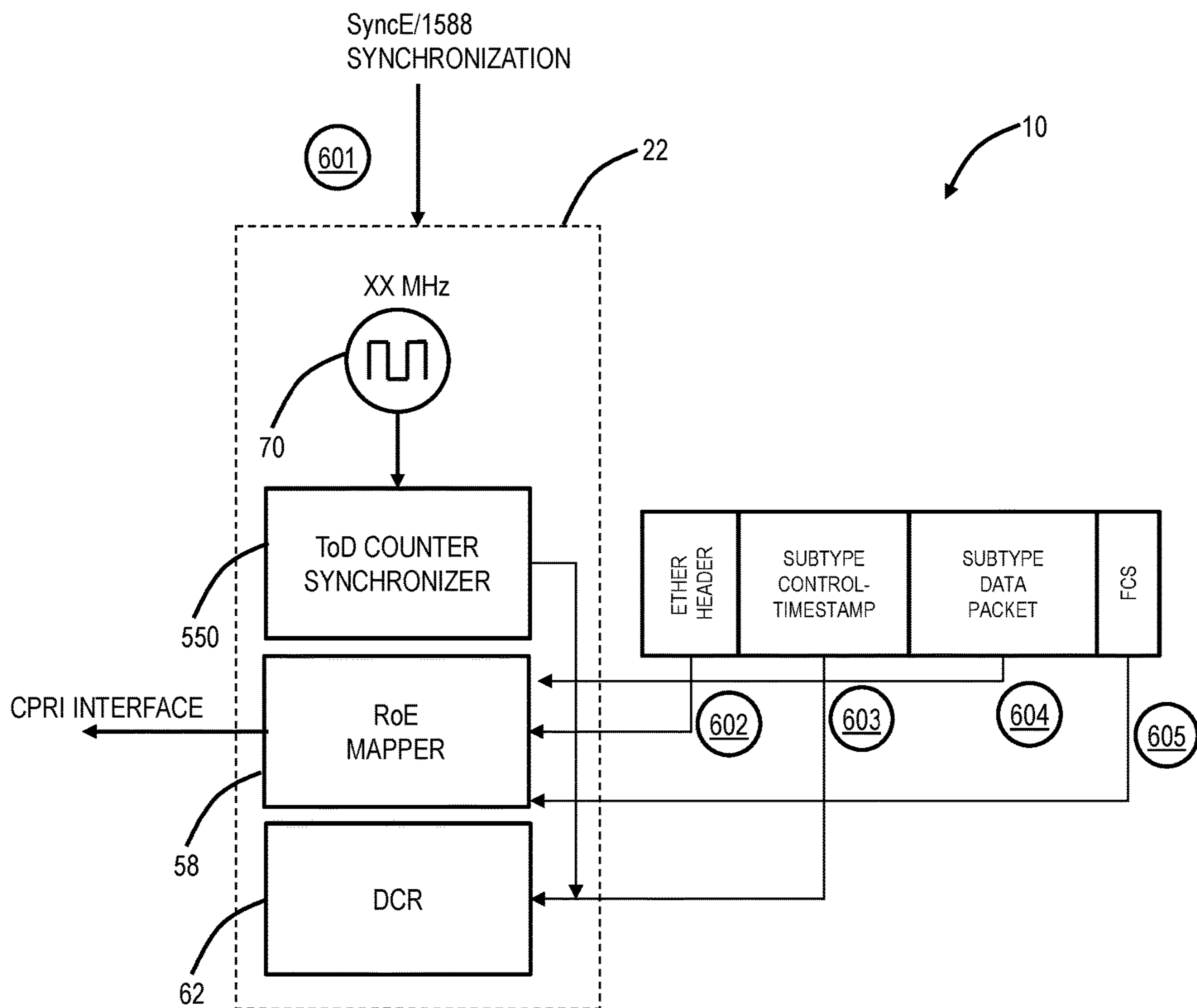
RoE control packet common frame format



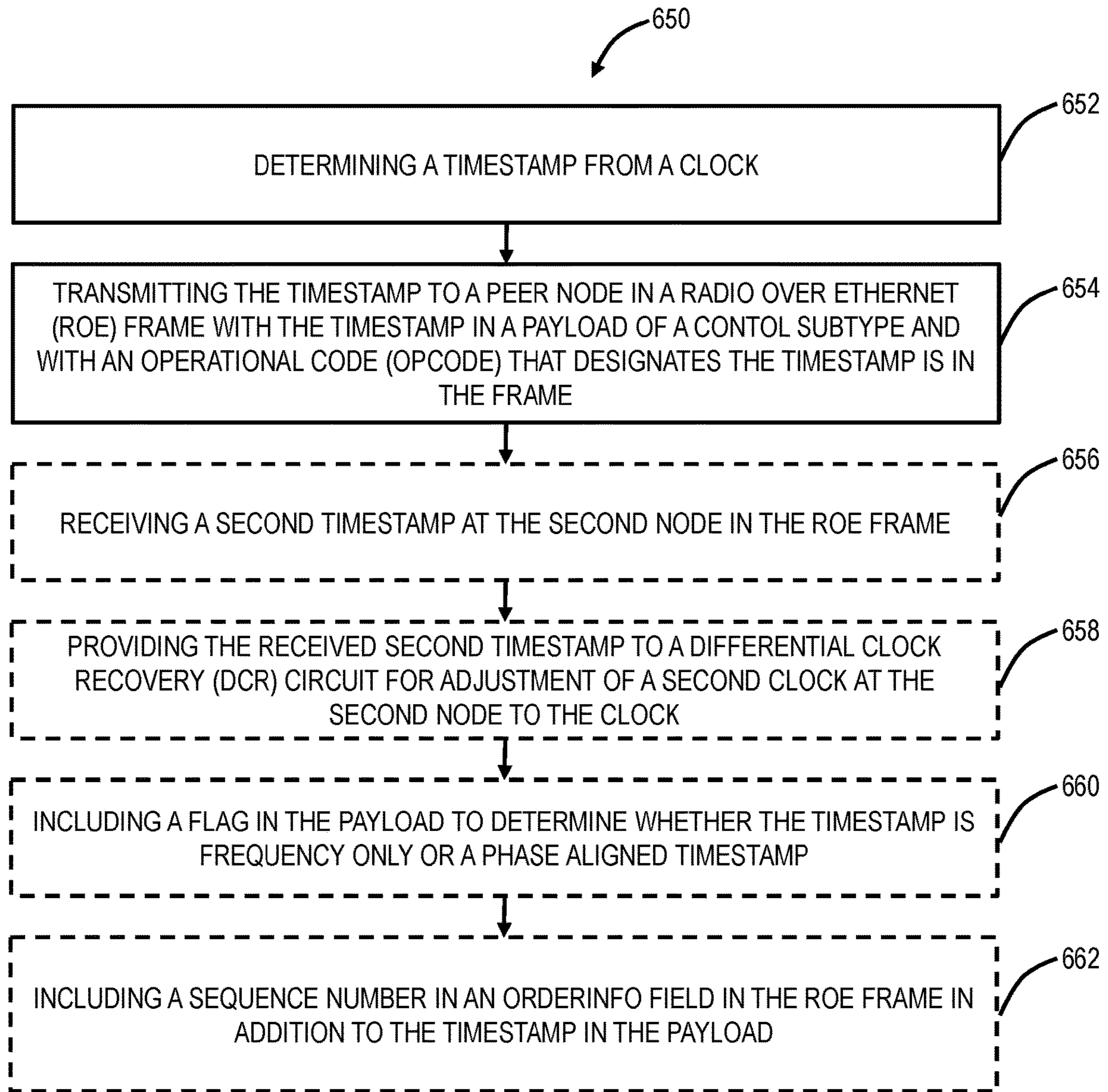
**FIG. 9**



**FIG. 10**



**FIG. 11**



**FIG. 12**



## DIFFERENTIAL CLOCK RECOVERY USING A GLOBAL REFERENCE TIME

### FIELD OF THE DISCLOSURE

The present disclosure generally relates to networking. More particularly, the present disclosure relates to systems and methods for Differential Clock Recovery (DCR) using a global reference time in a wireless fronthaul system that includes packet links and for systems and methods for carrying a timestamp in Radio over Ethernet (RoE).

### BACKGROUND OF THE DISCLOSURE

Conventional DCR implementations use a physical clock that is syntonized on each node (typically via Synchronous Ethernet (SyncE)) as a common reference. That is, to syntonize two nodes is to adjust the two nodes to operate on the same frequency. The frequency of a client clock is measured relative to this common reference at a receiving node and these measurements are used to synthesize the client clock at a transmitting node. SyncE is described, for example, in ITU-T Rec. G.8261/Y.1361 (August 2019), ITU-T Rec. G.8262/Y.1362 (November 2018), and ITU-T Rec. G.8264/Y.1364 (August 2017), the contents of each is incorporated by reference in their entirety.

The physical layer clock (i.e., SyncE using Ethernet interfaces) to syntonize two connected nodes. That is, node B recovers the physical layer Ethernet clock it receives from node A and uses it to syntonize its local clock. The node B can recover the frequency of the clock. However, because the propagation delay between nodes is unknown the phase of the node A clock cannot be recovered. Thus, clocks on node A and node B can be syntonized, but the clocks can have an unknown phase offset. Since this clock is not phase aligned on each node, this provides a mechanism to recover the frequency of a client signal at the destination, but not the phase.

Further, wireless fronthaul applications are moving towards use of packet connectivity between a radio (e.g., a Remote Radio Head (RRH)) and a Baseband Unit (BBU), namely Common Public Radio Interface (CPRI) over packet. From application level, it requires the phase to be synchronized as well and precise delay control can be measured and mitigated.

Also, the IEEE 1914.3 (2018) Standard for Radio over Ethernet Encapsulations and Mappings, the contents of which are incorporated by reference in their entirety, specifies an 'orderInfo' field which is used to indicate the proper sequence of packets. Radio over Ethernet (RoE) is defined as a native encapsulation header format for transmitting time-sensitive radio data and control data streams. RoE supports timestamping or sequence numbering to enable time synchronization of RoE packets and time alignment of streams. The 'orderInfo' field in the RoE header optionally supports a timestamp format, but generally uses a sequence number format.

Disadvantageously, operating withing compliance of IEEE 1914.3-2008 has significant limitations for carrying timestamp information. That is, the designated field is typically used for a sequence format. There is a need to support carrying a timestamp in other manners using RoE.

### BRIEF SUMMARY OF THE DISCLOSURE

In an embodiment, the present disclosure relates to systems and methods for Differential Clock Recovery (DCR)

using a global reference time in a wireless fronthaul system that includes CPRI over packet links. Specifically, the present disclosure utilizes a Global Reference Time to perform a Differential Clock Recovery (DCR) to allow a constant time delay of a client signal through a packet network and to preserve the phase of a client signal through the packet network. This also allows bidirectional paths through the packet network to have symmetric delays. That is, the present disclosure enables both frequency and phase synchronization across bidirectional paths. An example use case can include wireless fronthaul between RRH and BBU where the CPRI (or equivalent) links are carried in part over a packet network.

In another embodiment, the present disclosure relates to systems and methods for carrying a timestamp in Radio over Ethernet (RoE). The timestamp can be carried separate from the 'orderInfo' field which can be used for carrying a sequence number. In an embodiment, the present disclosure utilizes a subtype of a control packet and a specific operational code (opcode) such as Vendor Specific Data (VSD) to carry the timestamp as an example. It can also define a new opcode from control packet subtype by requesting ROE standard to re-purpose one of reserved opcode for this purpose. Also, the present disclosure includes a definition of the payload for the timestamp, and a flag to note if the timestamp is for frequency only or also a phase-aligned Time of Day (ToD) timestamp. Advantageously, this approach provides an efficient approach to carry timestamps on all RoE data types while maintaining compliance with the RoE standard, IEEE 1914.3-2008.

In an embodiment, an egress node includes circuitry configured to synchronize with a global reference time, receive a signal including a presentation time for when a specific part of the signal is to be transmitted, wherein the presentation time was determined by an ingress node with reference to the global reference time, determine an actual transmission time when the specific part of the signal is transmitted, and cause adjustment of a clock based on a time error derived from a difference between the presentation time and the actual transmission time. The egress node can be connected to the ingress node over a packet network, wherein the signal can include a wireless signal, and wherein the presentation time can be when the egress node should transmit the specific part. The adjustment can be configured to preserve a clock phase of the signal at the egress node. The adjustment can be configured to either speed up or slow down the clock to minimize the time error. The presentation time can be determined, at the ingress node, by adding a constant time delay to a reception time of the specific part. The signal can be a Radio over Ethernet (RoE) packet stream encapsulating a Common Public Radio Interface (CPRI) signal. The presentation time can be in an orderInfo field in a RoE header.

In another embodiment, an ingress node includes circuitry configured to synchronize with a global reference time, receive a signal for transmission to the egress node and detect a reference therein with respect to the global reference time, determine a presentation time for when the reference in the signal is to be transmitted from the egress node, and transmit the signal to the egress node with the presentation time included therein for the egress node to adjust its clock based on a time error derived from a difference between the presentation time and an actual transmission time. The ingress node can be connected to the egress node over a packet network, wherein the signal can include a wireless signal, and wherein the presentation time can be when the egress node should transmit the reference. The reference can



include any of a specific location in the client signal, payload, a Start of Frame, an Alignment Marker, and a specific location in a header. The presentation time can be determined by adding a constant time delay to a reception time of the specific part. The transmitted signal can be a Radio over Ethernet (RoE) packet stream encapsulating a Common Public Radio Interface (CPRI) signal. The presentation time can be in an orderInfo field in a RoE header.

In a further embodiment, a method includes, at an egress node, synchronizing with a global reference time; receiving a signal including a presentation time for when a specific part of the signal is to be transmitted, wherein the presentation time was determined by an ingress node with reference to the global reference time; determining an actual transmission time when the specific part of the signal is transmitted; and causing adjustment of a clock based on a time error derived from a difference between the presentation time and the actual transmission time. The method can further include, at the ingress node, synchronizing with the global reference time; receiving a client signal for transmission to the egress node and determining a reference therein with respect to the global reference time, wherein the reference is the specific part of the signal; determining the presentation time for when the reference in the client signal is to be transmitted at the egress node, and transmitting the client signal to the egress node with the presentation time included therein. The egress node can be connected to the ingress node over a packet network, wherein the signal can include a wireless signal, and wherein the presentation time can be when the egress node should transmit the specific part. The adjustment can be configured to preserve a clock phase of the client signal at the egress node. The adjustment can be configured to either speed up or slow down the clock to minimize the time error. The presentation time can be determined by adding a constant time delay to a reception time of the specific part. The signal can be a Radio over Ethernet (RoE) packet stream encapsulating a Common Public Radio Interface (CPRI) signal.

In yet another embodiment, a node includes a clock; and mapper circuitry configured to generate a timestamp from the clock, and transmit the timestamp to a peer node in a Radio over Ethernet (RoE) frame with the timestamp in a control subtype of the RoE frame and with an operational code (opcode) that designates the timestamp is in the frame. The node can further include a demapper circuit configured to receive a second timestamp from the peer node in a second RoE frame with the second timestamp in a control subtype of the second RoE frame and with an operational code (opcode) that designates the second timestamp is in the frame, and provide the received second timestamp to a Differential Clock Recovery (DCR) circuit for adjustment of the clock. The opcode can designate Vendor Specific Data (VSD) from the control subtype. The opcode can be one of a code from a reserved or undefined opcodes from the control subtype. The mapper circuitry can be further configured to include a flag in the control subtype to determine whether the timestamp is frequency only or a phase aligned timestamp. The control subtype can include an integer and a fractional value for the timestamp. The mapper circuitry can be further configured to include a sequence number in an orderInfo field of the control subtype in the RoE frame in addition to the timestamp in the control subtype.

In yet another embodiment, a node includes a clock; and a demapper circuit configured to receive a timestamp from a peer node in a Radio over Ethernet (RoE) frame with the timestamp in a control subtype of the RoE frame and with an operational code (opcode) that designates the timestamp

is in the frame, and provide the timestamp to a Differential Clock Recovery (DCR) circuit for adjustment of the clock. The node can further include mapper circuitry configured to generate a second timestamp from the clock, and transmit the second timestamp embedded in the control subtype of a second RoE frame to the peer node. The opcode can designate Vendor Specific Data (VSD) from the control subtype. The opcode can be one of a code from a reserved or undefined opcodes from the control subtype. The demapper circuitry can be further configured to receive a flag in the control subtype to determine whether the timestamp is frequency only or a phase aligned timestamp. The control subtype can include an integer and a fractional value for the timestamp. The demapper circuitry can be further configured to receive a sequence number in an orderInfo field in the RoE frame in addition to the timestamp in the control subtype.

In yet another further embodiment, a method includes generating a timestamp from a clock; and transmitting the timestamp to a peer node in a Radio over Ethernet (RoE) frame with the timestamp in a control subtype of the RoE frame and with an operational code (opcode) that designates the timestamp is in the RoE frame. The method can further include receiving a second timestamp from the peer node in a second RoE frame with the second timestamp in the control subtype of the second RoE frame and with an operational code (opcode) that designates the received second timestamp is in the received second RoE frame, and provide the received second timestamp to a Differential Clock Recovery (DCR) circuit for adjustment of the clock. The opcode can designate Vendor Specific Data (VSD) from the control subtype. The opcode can be one of a code from a reserved or undefined opcodes from the control subtype. The method can further include including a flag in the control subtype to determine whether the timestamp is frequency only or a phase aligned timestamp. The method can further include including a sequence number in an orderInfo field of the control subtype in the RoE frame in addition to the timestamp in the control subtype.

#### BRIEF DESCRIPTION OF THE DRAWINGS

The present disclosure is illustrated and described herein with reference to the various drawings, in which like reference numbers are used to denote like system components/method steps, as appropriate, and in which:

FIG. 1 is a network diagram of a network illustrating wireless fronthaul over a packet network;

FIG. 2 is a flowchart of a process for differential clock recovery;

FIG. 3 is a network diagram of a portion of the network of FIG. 1 illustrating components at the nodes that are connected by the packet network for implementing the process of FIG. 2;

FIG. 4 is a block diagram of an example implementation of a node;

FIG. 5 is a block diagram of an example controller, which can form a control module for the node of FIG. 4;

FIG. 6 is a flowchart of a process for Differential Clock Recovery (DCR) using a global reference time;

FIG. 7 is a network diagram of a portion of the network of FIG. 1 illustrating components at the nodes that are connected by the packet network for describing the RoE architecture;

FIG. 8 is a network diagram the network as illustrated in FIG. 7 with an example control packet over the packet network for conveying a timestamp;



## 5

FIG. 9 is a block diagram illustrating an RoE control packet common frame format and a payload;

FIG. 10 is a diagram of a node illustrating timestamp operation at the node with a mapper 52;

FIG. 11 is a diagram of a node illustrating timestamp operation at the node with a demapper; and

FIG. 12 is a flowchart of a process for conveying a timestamp in a RoE Ethernet frame.

DETAILED DESCRIPTION OF THE  
DISCLOSURE

Again, in an embodiment, the present disclosure relates to systems and methods for Differential Clock Recovery (DCR) using a global reference time in a wireless fronthaul system that includes packet links. Specifically, the present disclosure utilizes a Global Reference Time to perform a Differential Clock Recovery (DCR) to allow a constant time delay of a client signal through a packet network and to preserve the phase of a client signal through the packet network. This may also be used for regenerating a Time Division Multiplexing (TDM) signal after timing is lost through a packet network. This also allows bidirectional paths through the packet network to have symmetric delays. That is, the present disclosure enables both frequency and phase synchronization across bidirectional paths. An example use case can include wireless fronthaul between RRH and BBU where the CPRI (or equivalent) links are carried in part over a packet network.

Again, in another embodiment, the present disclosure relates to systems and methods for carrying a timestamp in Radio over Ethernet (RoE). The timestamp can be carried separate from the 'orderInfo' field which can be used for carrying a sequence number. In an embodiment, the present disclosure utilizes a subtype of a control packet and a specific operational code (opcode) such as Vendor Specific Data (VSD) to carry the timestamp as an example. It can also define a new opcode from control packet subtype by requesting ROE standard to re-purpose one of reserved opcode for this purpose. Also, the present disclosure includes a definition of the payload for the timestamp, and a flag to note if the timestamp is for frequency only or also a phase-aligned Time of Day (ToD) timestamp. Advantageously, this approach provides an efficient approach to carry timestamps on all RoE data types while maintaining compliance with the RoE standard, IEEE 1914.3-2008.

Wireless Fronthaul

As mobile networks evolve from a 4G centralized architecture to a 5G disaggregated and distributed network architecture, the 3GPP Radio Access Network (RAN) will need to converge. The 4G RAN makes use of predominantly a CPRI transport technology that is vendor proprietary, and, as such, comes at a high cost. To address the cost of higher capacity and higher density radio deployments in a 5G RAN, mobile economics necessitates a more cost efficient fronthaul solution. This RAN convergence will have the 4G RAN evolve from a CPRI fronthaul between the Radio Equipment (RE) and Radio Equipment Controller (REC) to an Ethernet packet transport, that can address the higher capacity and higher density at the economic curve of Ethernet technology.

There are different techniques to interconnect 4G RAN CPRI REs to RECs, all with various advantages and challenges. One approach is to use Ethernet transport technology, that is being pursued by the mobile industry and their

## 6

standards bodies to establish a foundation that is economically viable. One such standard is IEEE 1914.3, RoE, that defines standards to emulate the CPRI links over Ethernet. This requires accurate synchronization of both endpoints of the RoE emulation on the RE and REC, i.e., between a BBU 14 and an RRH 16.

RoE defines the encapsulation and mapper, and decapsulation and demapper for a CPRI RE for transport over an Ethernet packet transport network. In one direction, RE data (including I/Q data, control and management, and synchronization information) is transported using a CPRI frame structure mapped and encapsulated into an Ethernet frame. In the opposite direction, the Ethernet frame is demapped and the original CPRI frame is recovered from the RoE emulation. Due to the low latency and strict time synchronization requirement specified by CPRI, the demapper has to recover the clock and match the clock from the Ethernet-to-CPRI direction. Failure to recover an accurate frequency and/or phase clock may result in packet loss and Packet Delay Variation (PDV) (overrun and underrun conditions). Differential Clock Recovery (DCR) is one technique to recover the clock. In order to use DCR, the timestamp is applied on the encapsulation (CPRI-to-Ethernet) direction and is relayed over the transport network. This timestamp is then used by DCR algorithm on the Ethernet-to-CPRI direction to recover the requisite CPRI transmit clocks.

FIG. 1 is a network diagram of a network 10 illustrating wireless fronthaul over a packet network 12. The wireless fronthaul is presented as an example use case for the DCR presented herein. Wireless fronthaul includes the connectivity in a Radio Access Network (RAN) between a BBU 14 and an RRH 16. Fronthaul started when Long Term Evolution (LTE) networks moved the radios closer to the antennas and included a fiber link operating CPRI 18. The BBU 14 and the RRH 16 can be kilometers to tens of kilometers apart. The fiber link operating CPRI 18 can utilize CPRI rates of 2.458 Gbps, 3.072 Gbps, 4.915 Gbps, 6.144 Gbps, 9.830 Gbps, and beyond. The initial wireless fronthaul applications relied on direct optical CPRI connections between the BBU 14 and the RRH 16. However, operators are extending their deployments including the packet network 12 with routers/switches 20, 22 interfacing CPRI. Those skilled in the art will understand the routers/switches 20, 22 can be generally referred to as nodes 20, 22, network elements 20, 22, etc. The node 20 can connect to the BBU 14 via the CPRI 18 link and the node 22 can connect to the RRH 16 via the CPRI 18 link as well, with the nodes 20, 22 connected to one another via the packet network 12. Also, while FIG. 1 illustrates the packet network 12 between the BBU 14 and the RRH 16, other types of networks are also possible such as Optical Transport Network (OTN), Synchronous Optical Network (SONET), and the like, as well as multi-layer networks (e.g., packet over OTN), though the clock synchronization will be different from one to another type of networks. For example, in SONET, the clock is synchronized at each hop therefore no DCR is needed. For example, with emulation of SONET, then the DCR can be adopted.

The RRH 16 may include the RE having RF circuitry, such as converters, filters, oscillators, amplifiers, modulators, etc. These components allow the RRH to convert optical signals to electrical signals, and vice versa. This may be particularly useful in CPRI. Other features of the RRH 103 may include receiving/transmitting a desired band of signals from/to antennas, amplifying signals to desired power levels, filtering signals, converting signals, or other related actions. The BBU 14 may be a unit that processes baseband



at call sites for telecommunications systems. Baseband may refer a signal that has a very narrow and near-zero frequency range, e.g., low-pass or non-modulated signal. The BBU **14** may include, among other things, the REC which is responsible for communication through the physical interface.

CPRI defines three logical links for: (1) I/Q data; (2) timing data; and, (3) control and management data. RoE defines techniques for emulating each of these logical links, and further defines additional emulation techniques for the I/Q data. The emulation technique being used is explicitly indicated in the RoE common header of each RoE packet. In an embodiment, the emulation technique that the present disclosure applies to is Structure Agnostic Tunneling Mode (SA-TM). This emulation approach, unlike the other approaches, does not make use of a timestamp to synchronize the playout of the CPRI data, but rather requires that the RoE devices at each end of the emulated circuit be frequency and phase synchronized before the RoE transport can commence. Instead, 1914.3-2008 specifies the use of a sequence number. However, when no local synchronization is possible at the RE, most likely or even at the REC, less likely, a packet clock recovery technique using the RoE emulated service is needed. It is important to note that the CPRI clock frequency and phase alignment may or may not align with that of the transport network. As such, it is not sufficient to distribute a transport network's clocks for use by CPRI. The present disclosure includes techniques to enable the use of the RoE standard to extend the specification to enable CPRI clock distribution and recovery for the purpose of enabling CPRI synchronization across the packet network **12**.

Also, as noted in the background described herein, it is not possible using SyncE to ensure the same phase at the nodes **20**, **22**. As such, the present disclosure includes an approach for differentially encoding a client service clock relative to a Global Reference Time. That is, a client signal which is clocked at a frequency unrelated to the Global Reference Time is packetized and asynchronously transported through the packet network **12**. The client signal is regenerated with constant time delay to preserve phase at the destination.

The foregoing descriptions describe one direction in terms of differentially encoding a client service clock relative to a Global Reference Time. Of course, those skilled in the art will recognize a practical embodiment of any client connection in a network is bidirectional, and the approach described herein can be performed in both directions along with coordination between each direction for a symmetric time delay.

#### Process for Clock Recovery

FIG. **2** is a flowchart of a process **30** for differential clock recovery. The process **30** is described with reference from transmission from the node **20** to the node **22**, i.e., from right-to-left in the network **10** in FIG. **1**. In this context, the node **20** is referred to as network ingress and the node **22** is referred to as network egress. These nodes are referred to as packet network ingress and packet network egress. However, this can be generalized to network ingress and network egress nodes where the intermediate network is another type of network, e.g., OTN, etc. Also, the process **30** could equally be performed in the opposite direction, with the node **20** as the network egress and the node **22** as the network ingress. This process **30** of differential clock recovery requires that the nodes **20**, **22** have a synchronized reference time. Accordingly, the process **30** further includes synchronizing a global reference time between the nodes **20**, **22**,

such as via Precision Time Protocol (PTP) (IEEE 1588), a Global Navigation Satellite System (GNSS), etc.

The process **30** includes, at the packet network ingress, capturing a time of reception of a reference bit (or bits) with respect to the global reference time (step **32**). This step is about setting a start time based on a reference in an incoming signal to the packet network **12**. The signal reference bits may be at a particular location within a packet payload. Alternatively, the signal reference bits may be a Start of Frame (SOF), Start of Packet (SOP), an Alignment Marker, or any other feature of the client signal that can be recognized by the receiving node. That is, anything agreed to in advance by both the ingress and egress nodes (e.g., the nodes **20**, **22**) for determining a specific bit time instance.

The process **30** further includes, at the packet network ingress, determining a presentation time when the reference bit (or bits) should be transmitted at the destination in the future (step **34**). The presentation time is a future time that is used to specify when the bits, e.g., BBU symbols are to be transmitted onto the CPRI link to a radio, i.e., the RRH. The presentation time can be referenced to the reference bit (or bits) or to another unique marker. Further, the presentation time can be included in a packet header.

In an embodiment, the process **30** can use the 'orderInfo' field in the RoE header. The timestamp format may represent a presentation time used to specify the time at which the BBU symbols are to be transmitted onto a CPRI link to a radio. The timestamp format of the orderInfo field has 24 bits of 1 ns resolution and 5 bits for 0.03125 ns resolution. Similarly, it can be used to ensure that the link delay from the radio to the BBU is equal to the reverse direction. For example, the BBU sending CPRI assumes symmetric delay on its link to the RRH and uses a measured round-trip-delay divided by two to assess the delay to the RRH. Of course, the underlying assumption of CPRI is a direct fiber connection from BBU to RRH. In an embodiment, the presentation time, determined at step **34**, is included in the RoE header, such as in the orderInfo field. In another embodiment, the process **30** can use the various techniques described herein for carrying a timestamp in RoE,

The presentation time is determined by the packet network ingress by adding a constant time delay to the reception time of the reference bit (or bits). The expectation is that there is an automatic or manual service activation test run on the path (or paths if there is an alternate protection path provisioned) to characterize the packet latency and packet latency variation through the packet network. The objective is to know the worst case and best-case network packet delay via a statistical sampling of actual delays. The goal then is to set a minimum delay offset (where presentation time=reference bit receive time+the constant delay offset) which will be sufficient to avoid buffer underruns or overruns.

The process **30** further includes, at a packet network egress, after receiving the reference bit (or bits) and the presentation time, adjusting a client clock, at the packet network egress, by comparing the presentation time to an actual transmission time. That is, the client clock can be regenerated and adjusted by comparing the presentation time determined by the packet network ingress to the actual transmission time of the client signal reference bits. The difference of the desired transmission time determined by the packet network ingress and the actual transmission time at the packet network egress can be fed into a control circuit, as a time error, which speeds up or slows down the client



clock so that the error is minimized. In this manner, the time delay through the packet network **12** can be consistent/deterministic.

By sending the presentation time along with a corresponding reference bit, the time error can be determined by noting the difference between the current Global Reference Time when the reference bit is transmitted at the destination, and the desired presentation time. Phase and frequency adjustments are made to the transmit clock to minimize this time error. Minimizing this time error ensures that a constant time delay is met, and that the frequency and phase of the transmit clock at the destination will match that of the recovered clock at the source. Since the Global Reference Time is phase aligned on each node, it is now possible to preserve the phase of the client signal through the packet network **12**.

The process **30** leverages the concept of presentation time to also transparently transport the clock associated with the RoE encapsulated CPRI signal. This technique could also be applied to circuit emulation of any type of Time Division Multiplexing (TDM) signal, such as SONET or OTN.

#### Example Hardware Configuration

FIG. **3** is a network diagram of a portion of the network **10** illustrating components at the nodes **20**, **22** that are connected by the packet network **12** for implementing the process **30**. FIG. **3** illustrates the signal flow either from the BBU **14** to the RRH **16** or from the RRH **16** to the BBH **14**. FIG. **3** illustrates the components at the nodes **20**, **22**, and excludes the CPRI **18** links, the BBU **14**, and the RRH **16**, see FIG. **1**. For illustration purposes, FIG. **3** is described from the BBU **14** to the RRH **16**.

At the node **20**, the BBU **14** is connected to a transceiver **50** that terminates the CPRI **18** link. The transceiver **50** can be an optical device, such as a pluggable optical module. The transceiver **50** connects to a RoE mapper **52**. The RoE mapper **52** is configured to packetize client signals from the CPRI **18** link. The RoE mapper **52** can be the packet network ingress in the process **30** for the purposes of implementing the steps **32**, **34**. The RoE mapper **52** is configured to provide the presentation time using a global reference time **56** and a presentation time offset **54** based on detection of the reference bit (or bits). The RoE mapper **52** is configured to send RoE packets over the packet network **12** including an RoE header with the presentation time.

At the node **22**, the packet network **12** connects to a RoE demapper **58**. The RoE demapper **58** is configured to provide the opposite functionality as the RoE mapper **52**, namely to receive RoE packets and provide the corresponding client signals to a transceiver **60** that connects to the RRH **16** over the CPRI **18** link.

The RoE demapper **58** includes DCR control functionality **62** which can be implemented in hardware, software, firmware, and/or a combination thereof. The DCR control functionality **62** is configured to implement the step **36** with the global reference time **56** to determine a time error that is provided to a Phase Lock Loop (PLL) control interface **64** that can adjust (speed up/slow down) a clock **66**. The connections between the RoE demapper **58** and the DCR control functionality **62** include a reference bit presentation time, a reference bit transmitted (Tx), and a flow enable. The flow enable is asserted when the global reference time matches the reference bit presentation time of the packet at the head of a demapper queue. The reference bit Tx is asserted when a reference bit is transmitted to the transceiver

**60**. The reference bit presentation time is the value of the presentation time from the packet at the head of the demapper queue.

The various components in the nodes **20**, **22** can be realized in hardware modules, such as described in FIG. **4** with reference to an example implementation of the node **20**, **22**.

#### Example Node

FIG. **4** is a block diagram of an example implementation of a node **20**, **22**. Those of ordinary skill in the art will recognize FIG. **4** is a functional diagram in an oversimplified manner, and a practical embodiment may include additional components and suitably configured processing logic to support known or conventional operating features that are not described in detail herein.

In an embodiment, the node **20**, **22** is a packet switch, but those of ordinary skill in the art will recognize the systems and methods described herein can operate with other types of network elements and other implementations that support packet or TDM networking. In this embodiment, the node **20**, **22** includes a plurality of modules **102**, **104** interconnected via an interface **106**. The modules **102**, **104** are also known as blades, line cards, line modules, circuit packs, pluggable modules, etc., and generally refer to components mounted on a chassis, shelf, rack-mounted unit, pizza box, etc. of a data switching device, i.e., the node **20**, **22**. Each of the modules **102**, **104** can include numerous electronic devices and/or optical devices, including pluggable optical modules, mounted on a circuit board along with various interconnects, including interfaces to the chassis, shelf, etc.

Two example modules are illustrated with line modules **102** and a control module **104**. The line modules **102** include ports **108**, such as a plurality of Ethernet ports, CPRI ports, etc. For example, the line module **102** can include a plurality of physical ports disposed on an exterior of the module **102** for receiving ingress/egress connections. Additionally, the line modules **102** can include switching components to form a switching fabric via the interface **106** between all of the ports **108**, allowing data traffic to be switched/forwarded between the ports **108** on the various line modules **102**. The switching fabric is a combination of hardware, software, firmware, etc. that moves data coming into the node **20** out by the correct port **108** to the next node **22**. "Switching fabric" includes switching units in a node; integrated circuits contained in the switching units; and programming that allows switching paths to be controlled. Note, the switching fabric can be distributed on the modules **102**, **104**, in a separate module (not shown), integrated on the line module **102**, or a combination thereof.

The control module **104** can include a microprocessor, memory, software, and a network interface. Specifically, the microprocessor, the memory, and the software can collectively control, configure, provision, monitor, etc. the node **20**, **22**. The network interface may be utilized to communicate with an element manager, a network management system, etc. Additionally, the control module **104** can include a database that tracks and maintains provisioning, configuration, operational data, and the like.

Again, those of ordinary skill in the art will recognize the node **20**, **22** can include other components which are omitted for illustration purposes, and that the systems and methods described herein are contemplated for use with a plurality of different network elements with the node **20**, **22** presented as an example type of network element. For example, in another embodiment, the node **20**, **22** may include corre-



## 11

sponding functionality in a distributed fashion. In a further embodiment, the chassis and modules may be a single integrated unit, namely a rack-mounted shelf where the functionality of the modules **102**, **104** is built-in, i.e., a “pizza-box” configuration. That is, FIG. **4** is meant to provide a functional view, and those of ordinary skill in the art will recognize actual hardware implementations may vary.

## Example Controller

FIG. **5** is a block diagram of an example controller **200**, which can form a control module **104** for the node. The controller **200** can be part of the node **200**, or a stand-alone device communicatively coupled to the node **200**. Also, the controller **200** can be referred to in implementations as a control module, a shelf controller, a shelf processor, a system controller, etc. The controller **200** can include a processor **202** which is a hardware device for executing software instructions. The processor **202** can be any custom made or commercially available processor, a central processing unit (CPU), an auxiliary processor among several processors associated with the controller **200**, a semiconductor-based microprocessor (in the form of a microchip or chipset), or generally any device for executing software instructions. When the controller **200** is in operation, the processor **202** is configured to execute software stored within the memory, to communicate data to and from the memory, and to generally control operations of the controller **200** pursuant to the software instructions. The controller **200** can also include a network interface **204**, a data store **206**, memory **208**, an I/O interface **210**, and the like, all of which are communicatively coupled to one another and to the processor **202**.

The network interface **204** can be used to enable the controller **200** to communicate on a data communication network, such as to communicate to a management system, to the nodes **12**, **100**, and the like. The network interface **204** can include, for example, an Ethernet module. The network interface **204** can include address, control, and/or data connections to enable appropriate communications on the network. The data store **206** can be used to store data, such as control plane information, provisioning data, Operations, Administration, Maintenance, and Provisioning (OAM&P) data, etc. The data store **206** can include any of volatile memory elements (e.g., random access memory (RAM, such as DRAM, SRAM, SDRAM, and the like)), nonvolatile memory elements (e.g., ROM, hard drive, flash drive, CDROM, and the like), and combinations thereof. Moreover, the data store **206** can incorporate electronic, magnetic, optical, and/or other types of storage media. The memory **208** can include any of volatile memory elements (e.g., random access memory (RAM, such as DRAM, SRAM, SDRAM, etc.)), nonvolatile memory elements (e.g., ROM, hard drive, flash drive, CDROM, etc.), and combinations thereof. Moreover, the memory **208** may incorporate electronic, magnetic, optical, and/or other types of storage media. Note that the memory **208** can have a distributed architecture, where various components are situated remotely from one another, but may be accessed by the processor **202**. The I/O interface **210** includes components for the controller **200** to communicate with other devices.

## Process

FIG. **6** is a flowchart of a process **300** for Differential Clock Recovery (DCR) using a global reference time. The

## 12

process **300** includes, at an egress node, synchronizing with a global reference time (step **302**); receiving a signal including a presentation time for when a specific part of the signal is to be transmitted, wherein the presentation time was determined by the ingress node with reference to the global reference time (step **304**); determining an actual transmission time when the specific part of the signal is transmitted (step **306**); and causing adjustment of a clock based on a time error derived from a difference between the presentation time and the actual transmission time (step **308**).

The process **300** can further include, at the ingress node, synchronizing the global reference time (step **310**); receiving a signal for transmission to the egress node and determining a reference therein with respect to the global reference time, wherein the reference is the specific part of the signal (step **312**); determining the presentation time for when the reference in the signal is to be transmitted at the egress node (step **314**); and transmitting the signal to the egress node with the presentation time included therein (step **316**). Note, the steps **302-316** may be performed in different order than sequential as listed. That is, the ingress node steps **310-316** can be performed before the egress node steps **302-308**.

The egress node can be connected to the ingress node over a packet network, the signal can be a wireless signal, and the presentation time can be when a radio should transmit the specific part. The adjustment can be configured to preserve a clock phase of the global reference time at the egress node. The adjustment can be configured to either speed up or slow down the clock to minimize the time error. The presentation time can be determined by adding a constant time delay to a reception time of the specific part. The signal can be a Radio over Ethernet (RoE) packet stream encapsulating a Common Public Radio Interface (CPRI) signal. The presentation time can be included in an orderInfo field in a RoE header.

In another embodiment, an egress node includes circuitry configured to synchronize with a global reference time, receive a signal including a presentation time for when a specific part of the signal is to be transmitted, wherein the presentation time was determined by the ingress node with reference to the global reference time, determine an actual transmission time when the specific part of the signal is transmitted, and cause adjustment of a clock based on a time error derived from a difference between the presentation time and the actual transmission time.

In a further embodiment, an ingress node includes circuitry configured to synchronize with a global reference time, receive a signal for transmission to the egress node and detect a reference therein with respect to the global reference time, determine a presentation time for when the reference in the signal is to be transmitted at the egress node, and transmit the signal to the egress node with the presentation time included therein for the egress node to adjust its clock based on a time error derived from a difference between the presentation time and an actual transmission time.

## RoE Architecture

FIG. **7** is a network diagram of a portion of the network **10** illustrating components at the nodes **20**, **22** that are connected by the packet network **12** for describing the RoE architecture. Again, for illustration purposes, the node **20** includes the mapper **52** and the node **22** includes the demapper **58**, interconnected via the packet network **12**. The mapper **52** can include timestamp functionality **68** and the demapper **58** can include the DCR control functionality **62**,



## 13

and each of the functionality **62**, **68** can be circuitry configured to implement various functions. The objective of the DCR control functionality **62** and the timestamp functionality **68** and is to provide a common time reference (e.g., SyncE and PTP 1588 ToD).

The DCR algorithm is used to recover a clock **70** at the demapper **58** so that a stream output over a radio interface can match the input of a clock **72** at the mapper **52**, so that there is no underrun or overrun causing packet loss or packet variation, out of range of the application requirements. For the DCR algorithm, there is a need to convey a timestamp, from the timestamp functionality **68** on the mapper **52**, to the demapper **58**, such that the clocks **70**, **72** have a common reference. As described herein, RoE IEEE 1914.3 includes the orderInfo field for a possible timestamp, but this typically is used for a sequence number and is thus unavailable to provide a timestamp.

## RoE Timestamp

The present disclosure extends the RoE standard for carrying timestamps, by either using the existing “VSD—vendor specific data” opCode of the Control Packet sub-Type, or a new opCode specifically for a timestamp with approval of ROE standard or repurpose of one of the reserved opcode This approach could be applied to not only the current SA-TM emulation technique, but to any future emulation technique or other existing emulation techniques, so that any RoE data type can be covered by providing a generic opcode of timestamp while operating within compliance of IEEE 1914.3.

FIG. **8** is a network diagram the network **10** as illustrated in FIG. **7** with an example packet **400** over the packet network **12** for conveying a timestamp. RoE defines a subtype of a timing control packet, an Operations, Administration, and Maintenance (OAM) control packet, and a data packet with subtypes, and all of which include a common header. A structure-agnostic data packet does not use the OAM and timing control data, and only has one flow. In a line mode, the data packet uses a timestamp in the orderInfo field in the packet header, and in a tunnel mode, the data packet uses a sequence number in the orderInfo field. Thus, not all data packets have the timestamp.

The present disclosure includes use of a control packet to convey the timestamp. The control packet can have a control subtype opcode as defined in IEEE 1914.3-2007. In an embodiment, the opcode can be a Vendor Specific Data (VSD) opcode, e.g., 00000010b. In another embodiment, the opcode can be one selected from a reserved or unused range of opcodes, e.g., 00000100b. Of note, the mapper **52** and the demapper **58**, along with the DCR control functionality **62** and the timestamp functionality **68**, are configured to understand and process the selected opcode for the exchange of timestamp data. The control packet includes a data structure therein to convey the timestamp for DCR.

The data structure can include a data subtype and packet format makes use of the RoE common frame format with the payload carrying the timestamp information. FIG. **9** is a block diagram illustrating an RoE control packet common frame format **402** and a payload **404**. The RoE control packet common frame format **402** is from the RoE Specification, specifically FIG. **20** therein. The payload **404** includes a flag field, a timestamp ns (nanosecond) field, and a timestamp fractional ns field.

The control packet common frame format **402** includes a subtype field, a flowID field, a length field, an orderInfo

## 14

field, an opcode field, and the payload **404**. Specifically, the payload **404** is in the payload bytes of the control packet common frame format **402**.

In an embodiment, the overall data structure of the control packet common frame format **402** can include

Field	Example value	Notes
SubType	0x0 (0000,0000b)	defined by 1914.3 as control packet (i.e for OAM, timing)
Opcode	0x2 (0000,0010b)	defined by 1914.3 as VSD (vendor specific data)
FlowId	0xff (1111,1111b)	required to be all ones by 1914.3
Length	Various	4 bytes - the length of the payload 404
orderInfo	Sequence number	
Flag	1 or 0	1: timestamp by frequency; 0: timestamp by PTP synchronized ToD

## The payload can include

Bits	Value
0:2	flag, 1: timestamp by frequency; 0: timestamp by PTP synchronized ToD
2:26	timestamp of ns
27:31	Fractional ns

## Timestamp Operation of the Mapper

FIG. **10** is a diagram of the node **20** illustrating timestamp operation at the node **20** with the mapper **52**. In this example, a subtype of a control VSD timestamp is built into the Ethernet frame in the RoE mapper **52**. The clock **72** can be synchronized by SyncE and/or PTP 1588, and a ToD counter synchronizer **540** can connect to the clock (step **501**). The RoE mapper **52** is configured to build an Ethernet header (step **502**). The RoE mapper **52** is configured to retrieve a timestamp value from the timestamp functionality **68** and build the subtype of a control timestamp (step **503**). The RoE mapper **52** receives an incoming radio stream (e.g., from the CPRI interface) and incorporates the data in a data packet (step **504**). Finally, the RoE mapper **52** builds a Frame Check Sequence (FCS) and the frame is sent (step **505**).

## Timestamp Operation of the Demapper

FIG. **11** is a diagram of the node **22** illustrating timestamp operation at the node **22** with the demapper **58**. In this example, a subtype of a control VSD timestamp is extracted from the Ethernet frame in RoE demapper **58**, via the DCR control functionality **62**. The clock **70** can be synchronized by SyncE and/or PTP 1588, and a ToD counter synchronizer **550** can connect to the clock (step **601**). The RoE demapper **58** extracts the Ethernet header (step **602**). The RoE demapper **58** decapsulates the subtype of the control timestamp (step **603**). The demapper **58** decapsulates the data packet subtype (step **604**). Finally, if the FCS indicates a valid timestamp, the timestamp is pushed to the DCR functionality **62**.

## Timestamp Process

FIG. **12** is a flowchart of a process **650** for conveying a timestamp in a RoE Ethernet frame. The process **650** includes determining a timestamp from a clock (step **652**);



and transmitting the timestamp to a second node in a Radio over Ethernet (RoE) frame with the timestamp in a payload and with an operational code (opcode) that designates the timestamp is in the frame (step 654). The process 650 can further include receiving a second timestamp at the second node in the RoE frame (step 656), and providing the received second timestamp to a Differential Clock Recovery (DCR) circuit for adjustment of a second clock at the second node to the clock (step 658).

The opcode can designate Vendor Specific Data (VSD). The opcode can be one of a code from a reserved or undefined opcodes. The process 650 can further include including a flag in the payload to determine whether the timestamp is frequency only or a phase aligned timestamp (step 660). The process 650 can further include including a sequence number in an orderInfo field in the RoE frame in addition to the timestamp in the payload (step 662).

It will be appreciated that some embodiments described herein may include or utilize one or more generic or specialized processors (“one or more processors”) such as microprocessors; Central Processing Units (CPUs); Digital Signal Processors (DSPs); customized processors such as Network Processors (NPs) or Network Processing Units (NPU), Graphics Processing Units (GPUs), or the like; Field-Programmable Gate Arrays (FPGAs); and the like along with unique stored program instructions (including both software and firmware) for control thereof to implement, in conjunction with certain non-processor circuits, some, most, or all of the functions of the methods and/or systems described herein. Alternatively, some or all functions may be implemented by a state machine that has no stored program instructions, or in one or more Application-Specific Integrated Circuits (ASICs), in which each function or some combinations of certain of the functions are implemented as custom logic or circuitry. Of course, a combination of the aforementioned approaches may be used. For some of the embodiments described herein, a corresponding device in hardware and optionally with software, firmware, and a combination thereof can be referred to as “circuitry configured to,” “logic configured to,” etc. perform a set of operations, steps, methods, processes, algorithms, functions, techniques, etc. on digital and/or analog signals as described herein for the various embodiments.

Moreover, some embodiments may include a non-transitory computer-readable medium having instructions stored thereon for programming a computer, server, appliance, device, processor, circuit, etc. to perform functions as described and claimed herein. Examples of such non-transitory computer-readable medium include, but are not limited to, a hard disk, an optical storage device, a magnetic storage device, a Read-Only Memory (ROM), a Programmable ROM (PROM), an Erasable PROM (EPROM), an Electrically EPROM (EEPROM), Flash memory, and the like. When stored in the non-transitory computer-readable medium, software can include instructions executable by a processor or device (e.g., any type of programmable circuitry or logic) that, in response to such execution, cause a processor or the device to perform a set of operations, steps, methods, processes, algorithms, functions, techniques, etc. as described herein for the various embodiments.

Although the present disclosure has been illustrated and described herein with reference to preferred embodiments and specific examples thereof, it will be readily apparent to those of ordinary skill in the art that other embodiments and examples may perform similar functions and/or achieve like results. All such equivalent embodiments and examples are

within the spirit and scope of the present disclosure, are contemplated thereby, and are intended to be covered by the following claims.

What is claimed is:

1. An egress node comprising:  
circuitry configured to

synchronize with a global reference time,  
receive a signal including a presentation time for when a specific part of the signal is to be transmitted, wherein the presentation time is in an orderInfo field in a Radio over Ethernet (RoE) header, and was determined by an ingress node with reference to the global reference time by adding a constant time delay to a reception time of the specific part,  
determine an actual transmission time when the specific part of the signal is transmitted, and  
cause adjustment of a clock based on a time error derived from a difference between the presentation time and the actual transmission time, wherein the adjustment is configured to preserve a clock phase of the signal at the egress node.

2. The egress node of claim 1, wherein the egress node is connected to the ingress node over a packet network, wherein the signal comprises a wireless signal, and wherein the presentation time is when the egress node should transmit the specific part.

3. The egress node of claim 1, wherein the adjustment is configured to either speed up or slow down the clock to minimize the time error.

4. The egress node of claim 1, wherein the signal is a Radio over Ethernet (RoE) packet stream encapsulating a Common Public Radio Interface (CPRI) signal.

5. An ingress node comprising:  
circuitry configured to

synchronize with a global reference time,  
receive a signal for transmission to the egress node and detect a reference therein with respect to the global reference time,  
determine a presentation time for when the reference in the signal is to be transmitted from the egress node by adding a constant time delay to a reception time of the specific part is in an orderInfo field in a Radio over Ethernet (RoE) header, and  
transmit the signal to the egress node with the presentation time included therein for the egress node to adjust its clock based on a time error derived from a difference between the presentation time and an actual transmission time, wherein the adjustment is configured to preserve a clock phase of the signal at the egress node.

6. The ingress node of claim 5, wherein the ingress node is connected to the egress node over a packet network, wherein the signal comprises a wireless signal, and wherein the presentation time is when the egress node should transmit the reference.

7. The ingress node of claim 5, wherein the reference includes any of a specific location in the client signal, payload, a Start of Frame, an Alignment Marker, and a specific location in a header.

8. The ingress node of claim 5, wherein the transmitted signal is a Radio over Ethernet (RoE) packet stream encapsulating a Common Public Radio Interface (CPRI) signal.

9. A method comprising, at an egress node:  
synchronizing with a global reference time;

receiving a signal including a presentation time for when a specific part of the signal is to be transmitted, wherein the presentation time is in an orderInfo field in a Radio

**17**

over Ethernet (RoE) header, and was determined by an ingress node with reference to the global reference time by adding a constant time delay to a reception time of the specific part;

determining an actual transmission time when the specific 5  
part of the signal is transmitted; and  
causing adjustment of a clock based on a time error derived from a difference between the presentation time and the actual transmission time, wherein the adjustment is configured to preserve a clock phase of the 10  
signal at the egress node.

**10.** The method of claim **9**, further comprising at the ingress node  
synchronizing with the global reference time;  
receiving a client signal for transmission to the egress 15  
node and determining a reference therein with respect to the global reference time, wherein the reference is the specific part of the signal;

**18**

determining the presentation time for when the reference in the client signal is to be transmitted at the egress node, and  
transmitting the client signal to the egress node with the presentation time included therein.

**11.** The method of claim **9**, wherein the egress node is connected to the ingress node over a packet network, wherein the signal comprises a wireless signal, and wherein the presentation time is when the egress node should transmit the specific part.

**12.** The method of claim **9**, wherein the adjustment is configured to either speed up or slow down the clock to minimize the time error.

**13.** The method of claim **9**, wherein the signal is a Radio over Ethernet (RoE) packet stream encapsulating a Common Public Radio Interface (CPRI) signal.

\* \* \* \* \*