



US011162814B2

(12) **United States Patent**
Ito et al.

(10) **Patent No.:** **US 11,162,814 B2**
(45) **Date of Patent:** **Nov. 2, 2021**

(54) **POSITION DETECTING DEVICE, AND METHOD OF MANUFACTURING POSITION DETECTING DEVICE**

(71) Applicant: **DENSO CORPORATION**, Kariya (JP)

(72) Inventors: **Takeshi Ito**, Kariya (JP); **Takamitsu Kubota**, Kariya (JP); **Yoshiyuki Kono**, Kariya (JP)

(73) Assignee: **DENSO CORPORATION**, Kariya (JP)

(*) Notice: Subject to any disclaimer, the term of this patent is extended or adjusted under 35 U.S.C. 154(b) by 124 days.

(21) Appl. No.: **16/264,851**

(22) Filed: **Feb. 1, 2019**

(65) **Prior Publication Data**

US 2019/0162556 A1 May 30, 2019

Related U.S. Application Data

(63) Continuation of application No. PCT/JP2017/029300, filed on Aug. 14, 2017.

(30) **Foreign Application Priority Data**

Aug. 23, 2016 (JP) JP2016-162956
May 30, 2017 (JP) JP2017-106790

(51) **Int. Cl.**

G01D 5/14 (2006.01)
G01D 5/16 (2006.01)
G01D 3/08 (2006.01)

(52) **U.S. Cl.**

CPC **G01D 5/142** (2013.01); **G01D 3/08** (2013.01); **G01D 5/145** (2013.01); **G01D 5/16** (2013.01)

(58) **Field of Classification Search**

CPC G01D 5/12; G01D 5/16; G01D 5/142; G01D 5/145; G01D 11/30; G01D 11/245; G01D 3/08; G01B 7/30

See application file for complete search history.

(56) **References Cited**

U.S. PATENT DOCUMENTS

10,199,567	B2 *	2/2019	Itou	H01L 43/065
2008/0197481	A1 *	8/2008	Tokuhara	H01L 23/24 257/698
2011/0221432	A1 *	9/2011	Oota	G01R 33/0011 324/251
2013/0249544	A1 *	9/2013	Vig	G01R 33/0047 324/252
2014/0111193	A1 *	4/2014	Mizunuma	G01D 5/12 324/207.25
2015/0345994	A1	12/2015	Mase		
2018/0102473	A1 *	4/2018	Itou	H01L 43/04
2019/0162518	A1 *	5/2019	Uchida	G01D 5/12
2019/0170498	A1 *	6/2019	Ito	G01D 11/245
2019/0170499	A1 *	6/2019	Ito	G01D 5/145

* cited by examiner

Primary Examiner — Jermele M Hollington

(74) *Attorney, Agent, or Firm* — Nixon & Vanderhye, PC

(57) **ABSTRACT**

A position detecting device includes an IC package, a first terminal line, a ground terminal line, a power supply terminal line, a second terminal line, a bypass terminal line, motor terminal lines, and a connector portion. A bypass terminal line is positioned on an opposite side of the ground terminal line across the first terminal line or the second terminal line and is connected to a bypass portion of the ground terminal line which connects to the ground connection portion. In the connector portion, the motor terminal line, the bypass terminal line, the second terminal line, the power supply terminal line, and the first terminal line are placed in this order.

14 Claims, 13 Drawing Sheets

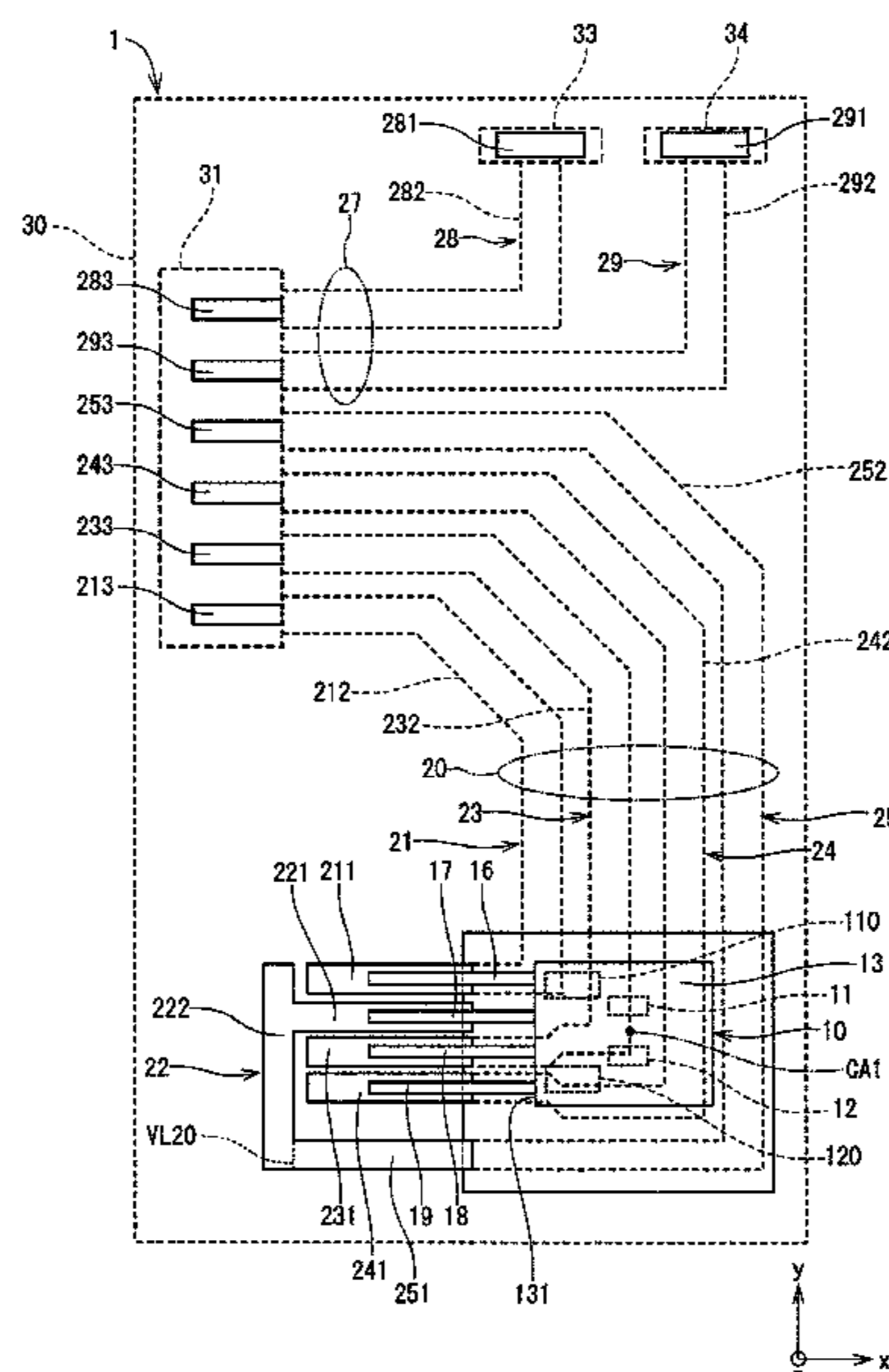
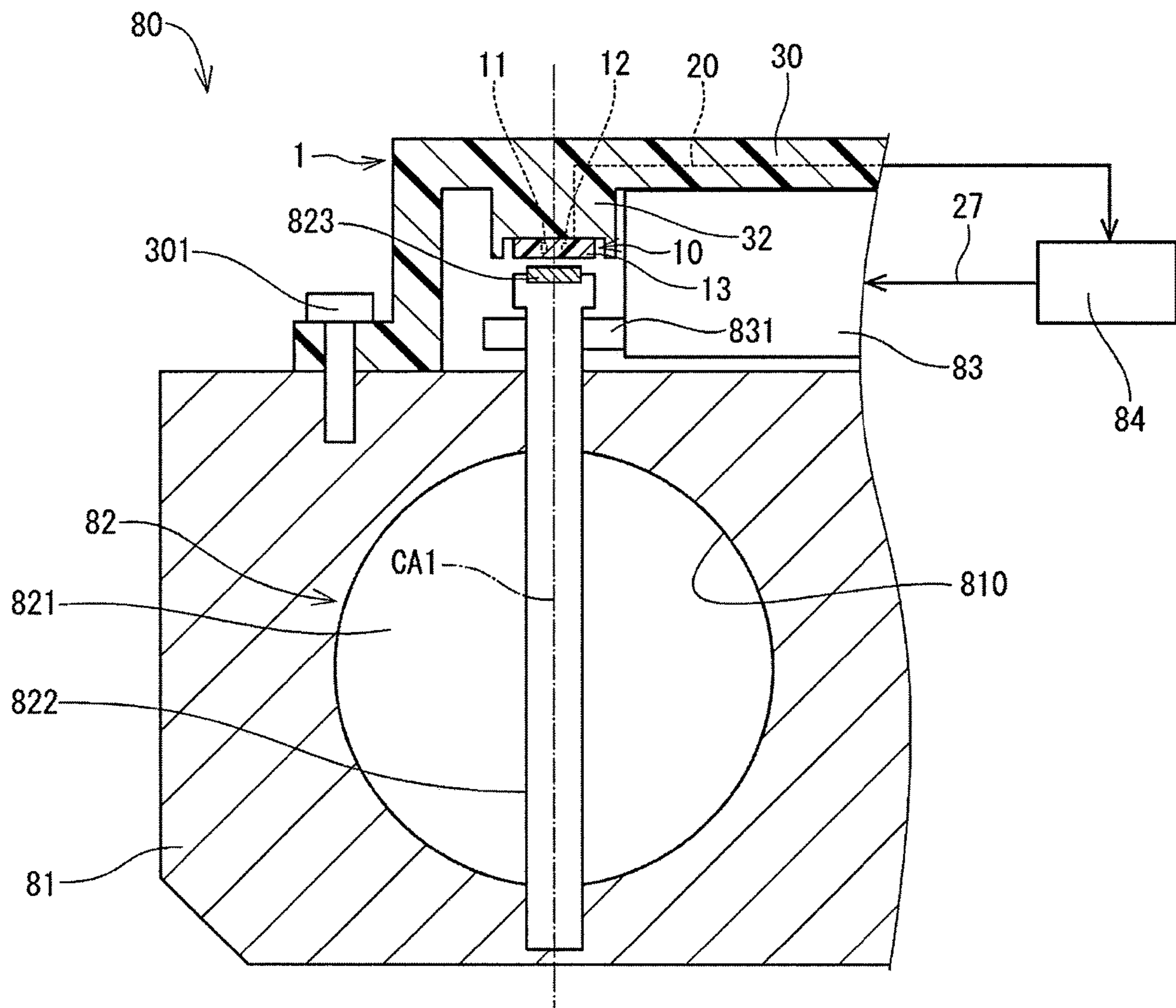

FIG. 1



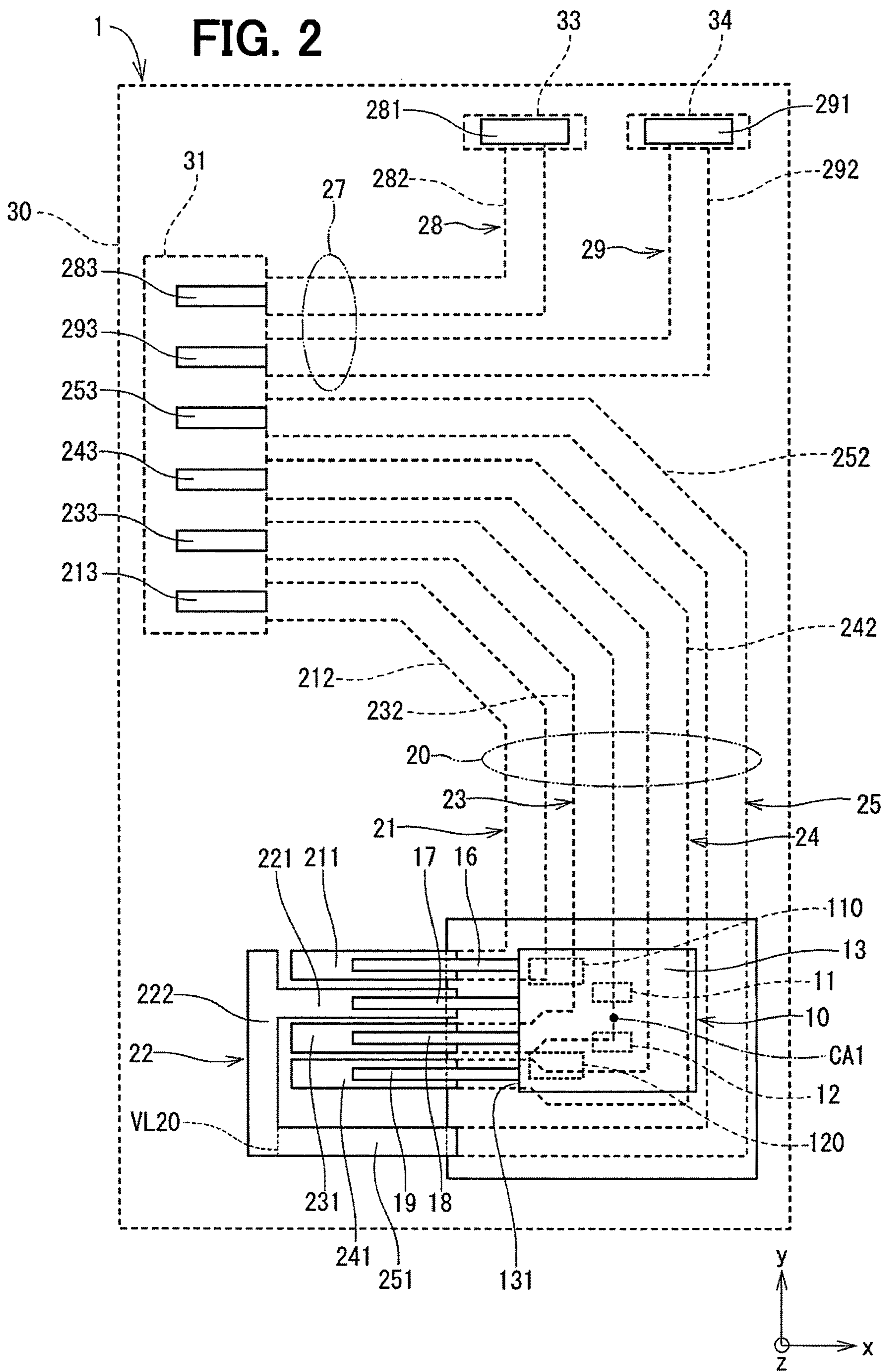

FIG. 3A

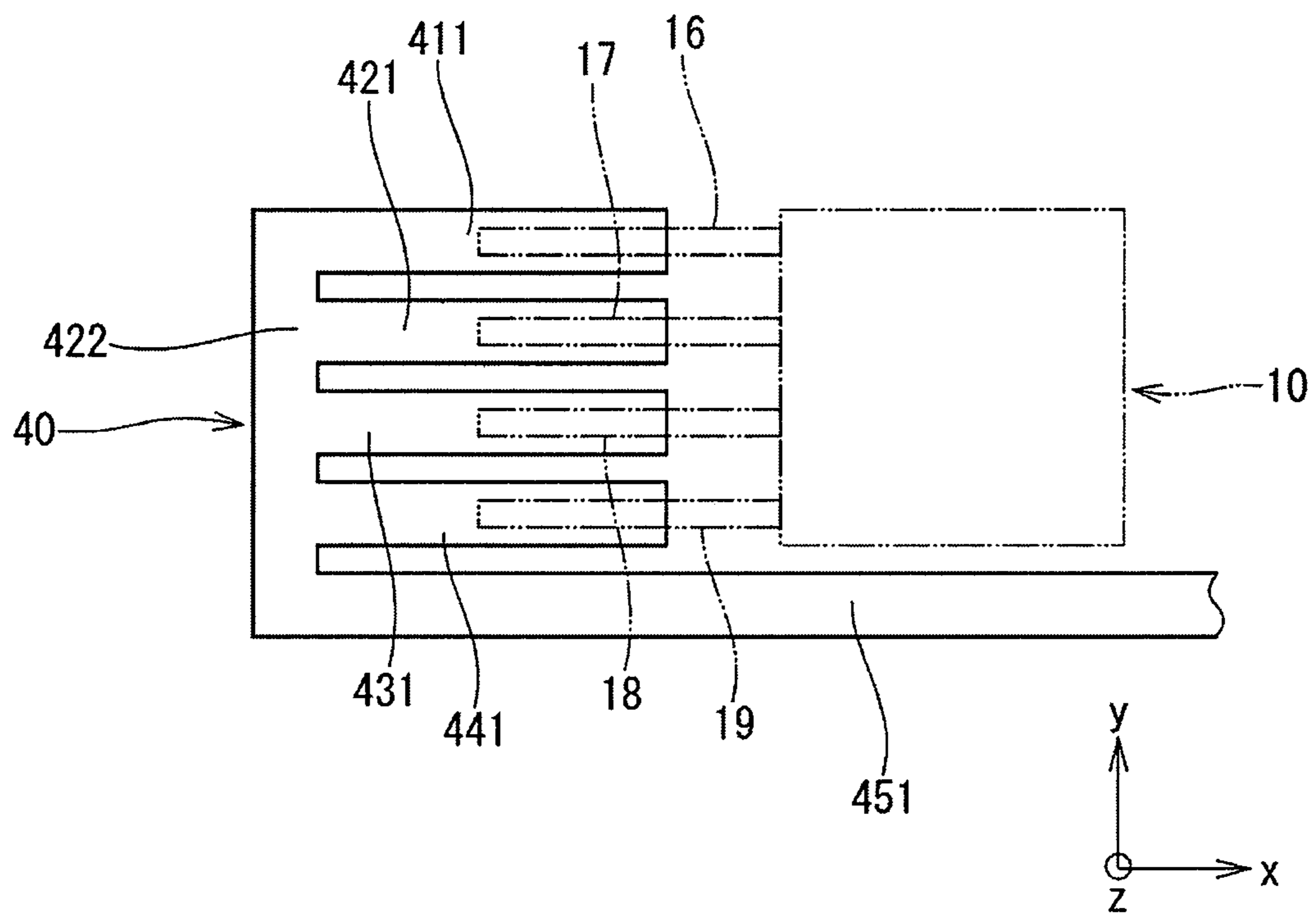

FIG. 3B

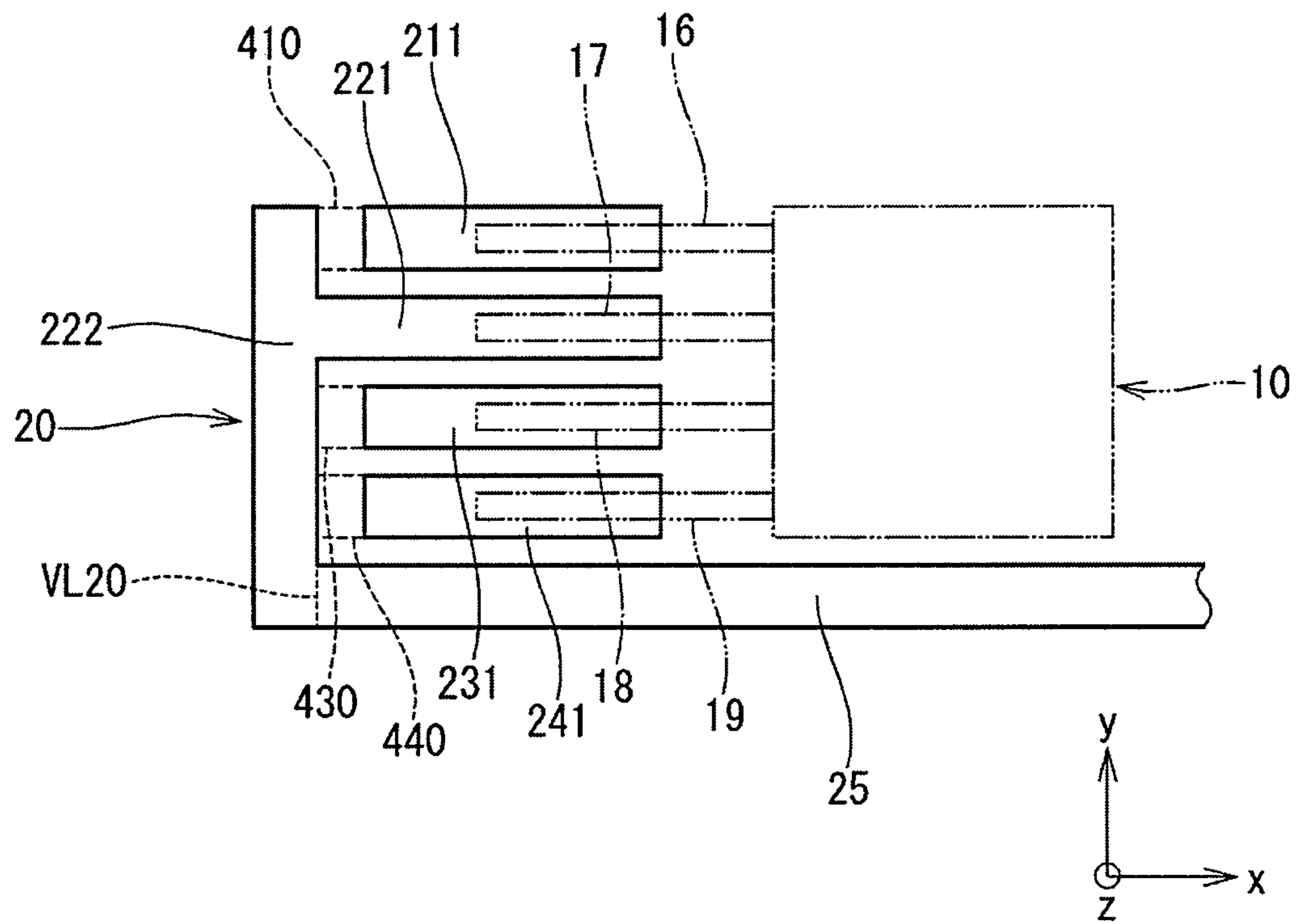

FIG. 4A

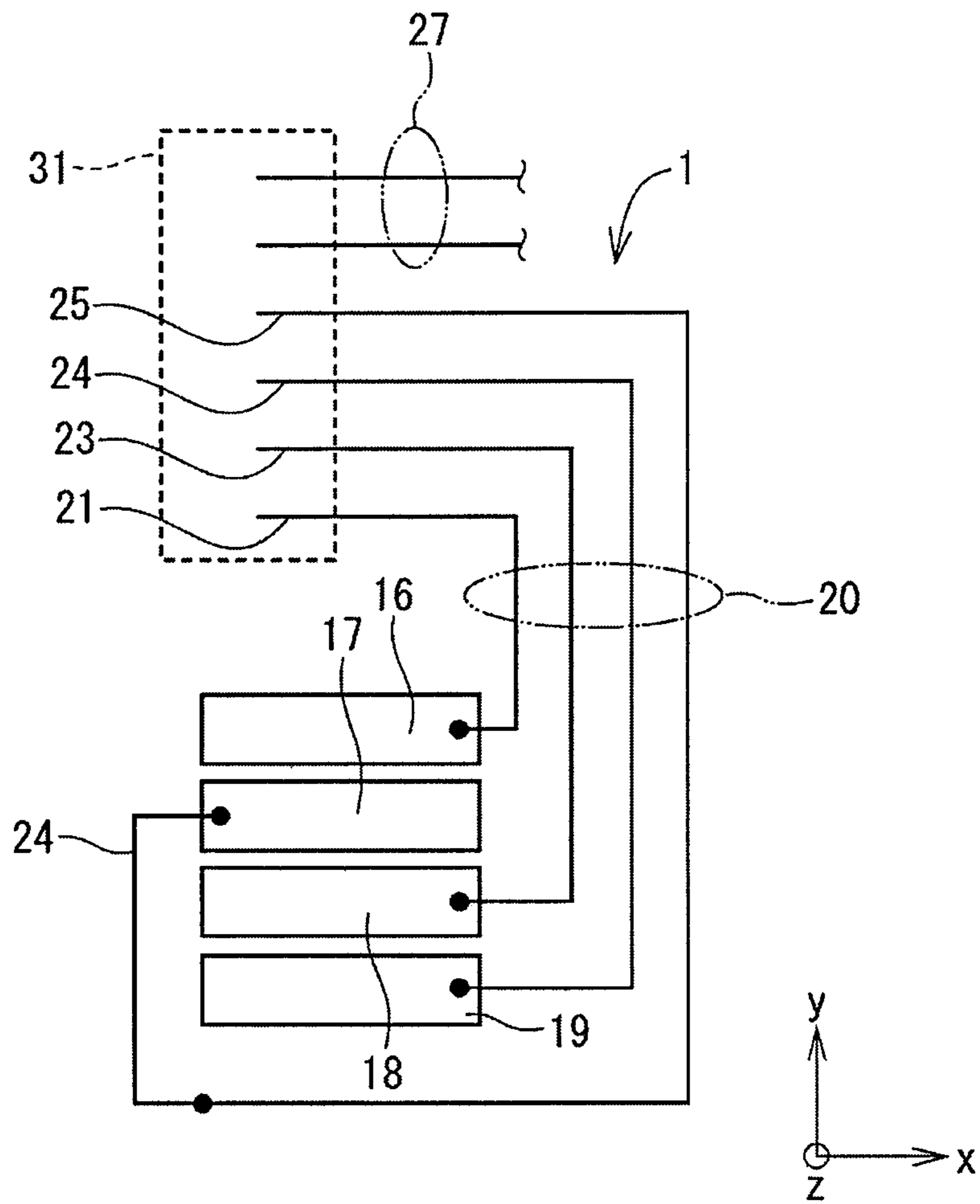

FIG. 4B

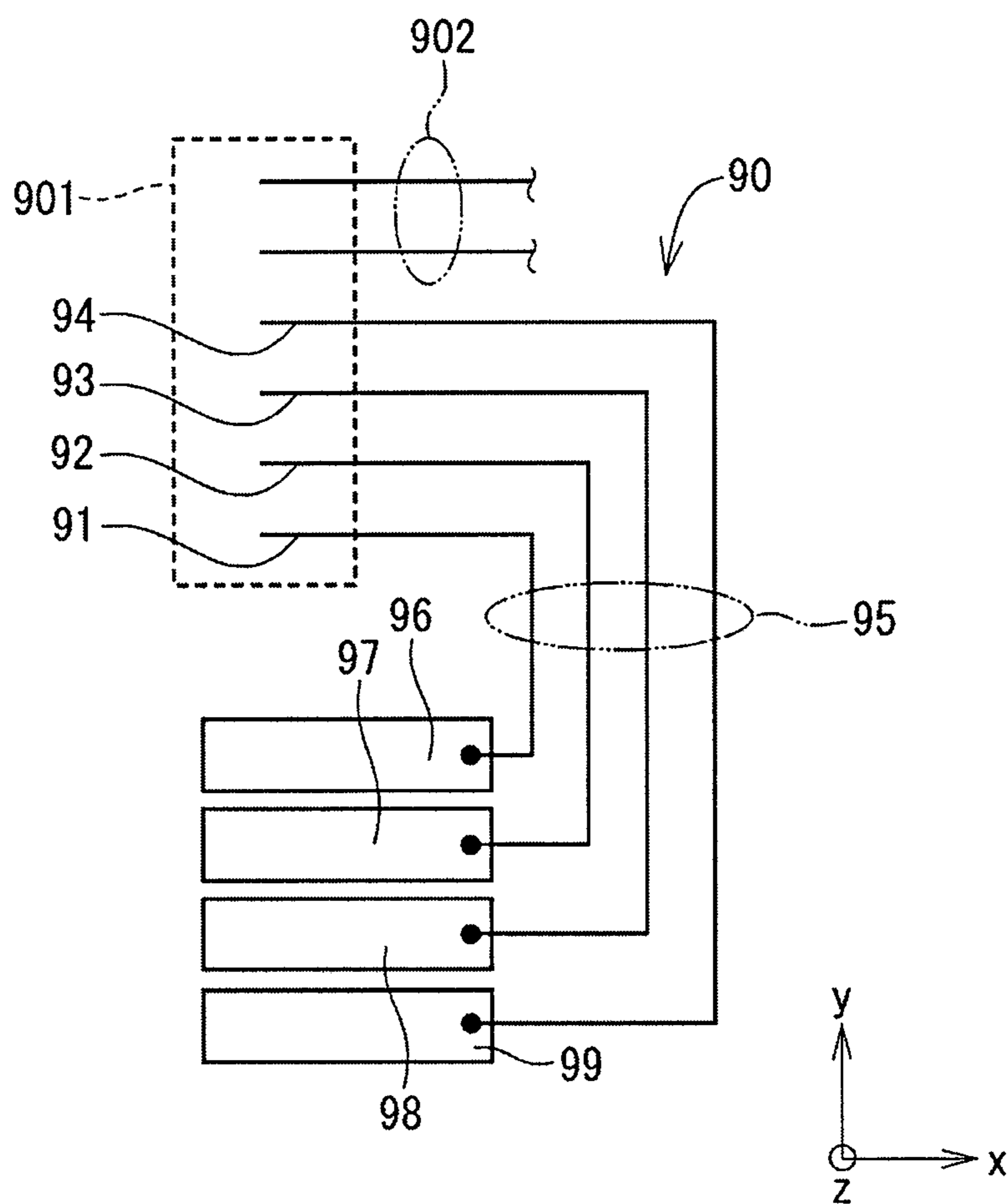
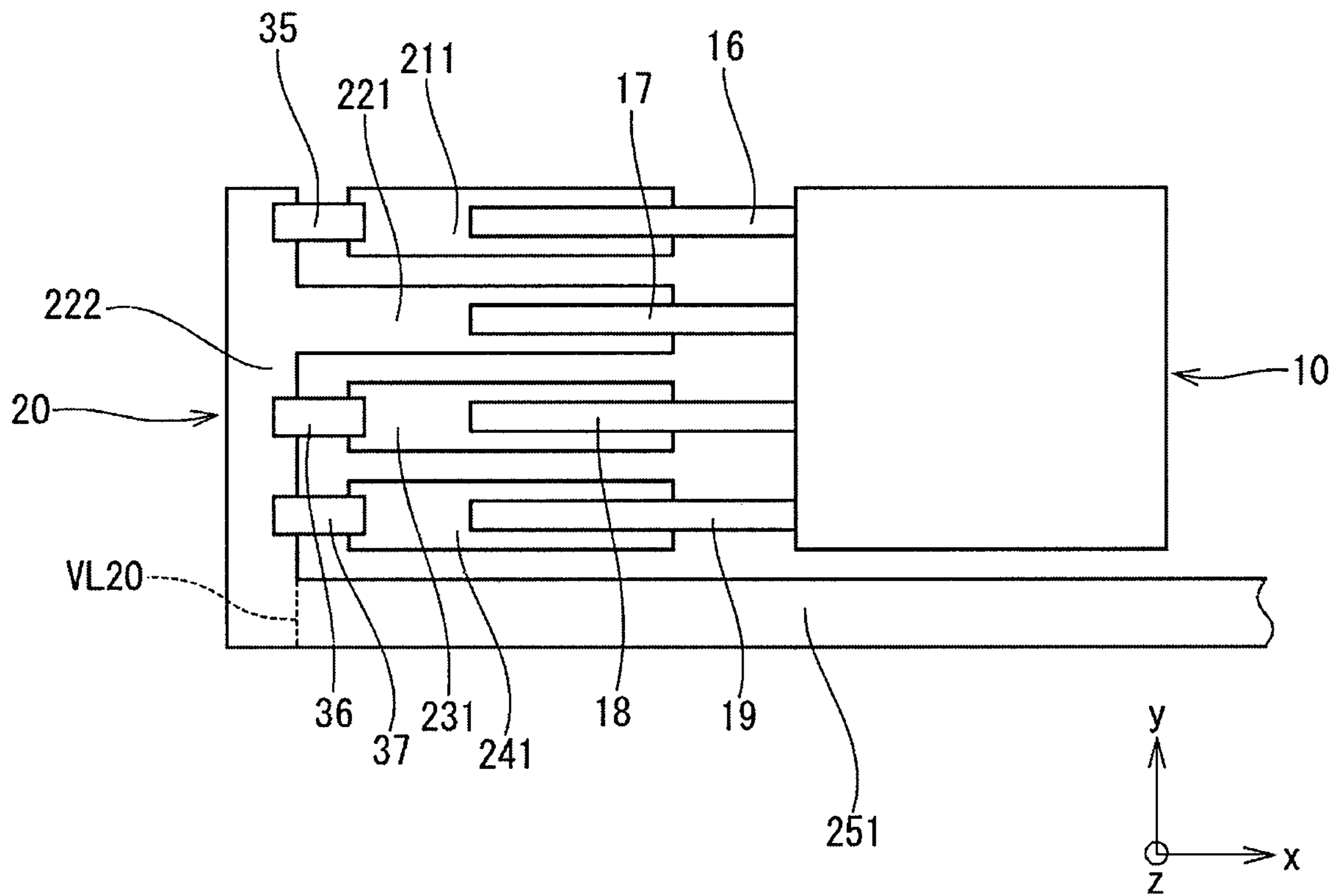

FIG. 5



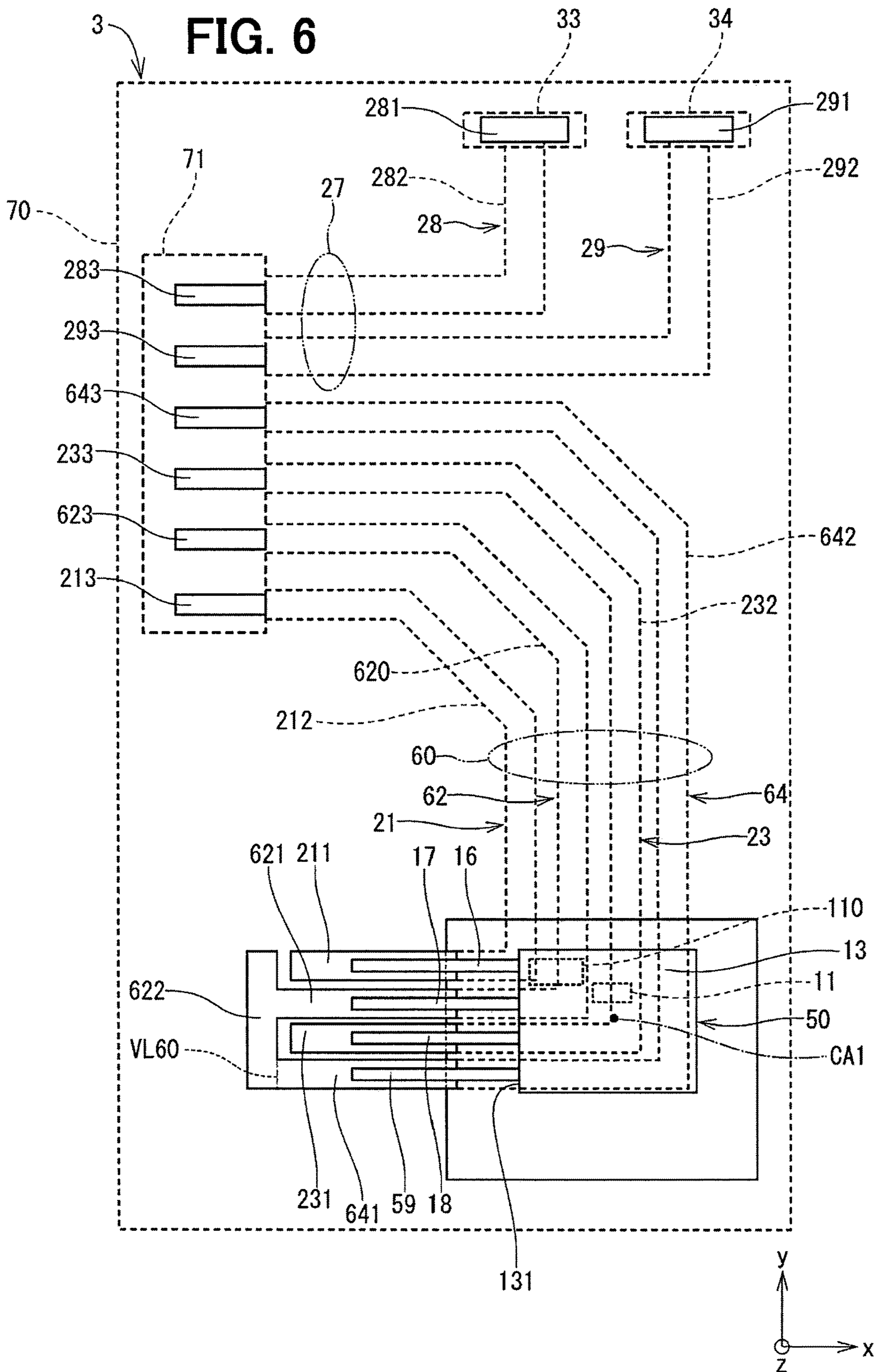

FIG. 7A

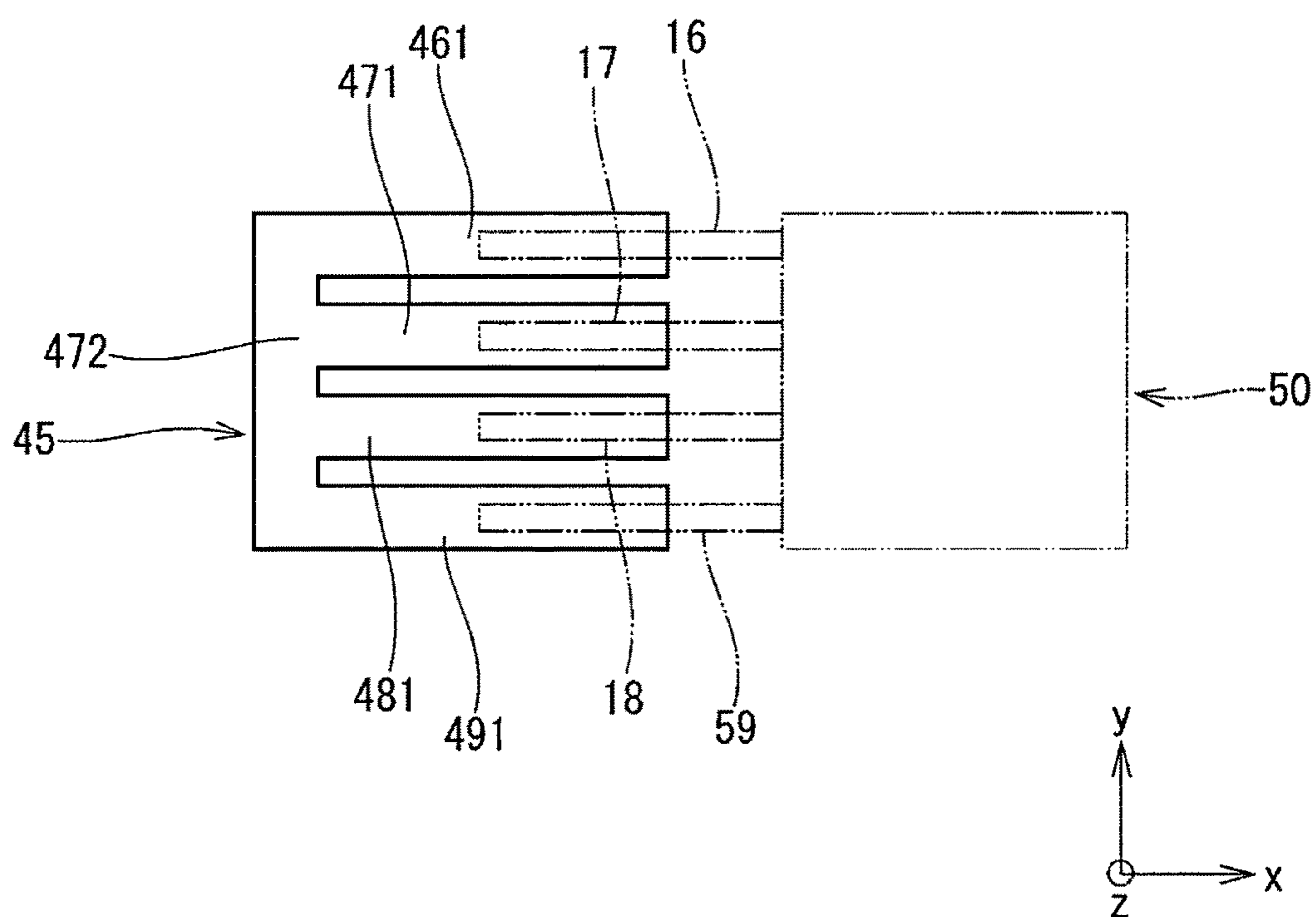

FIG. 7B

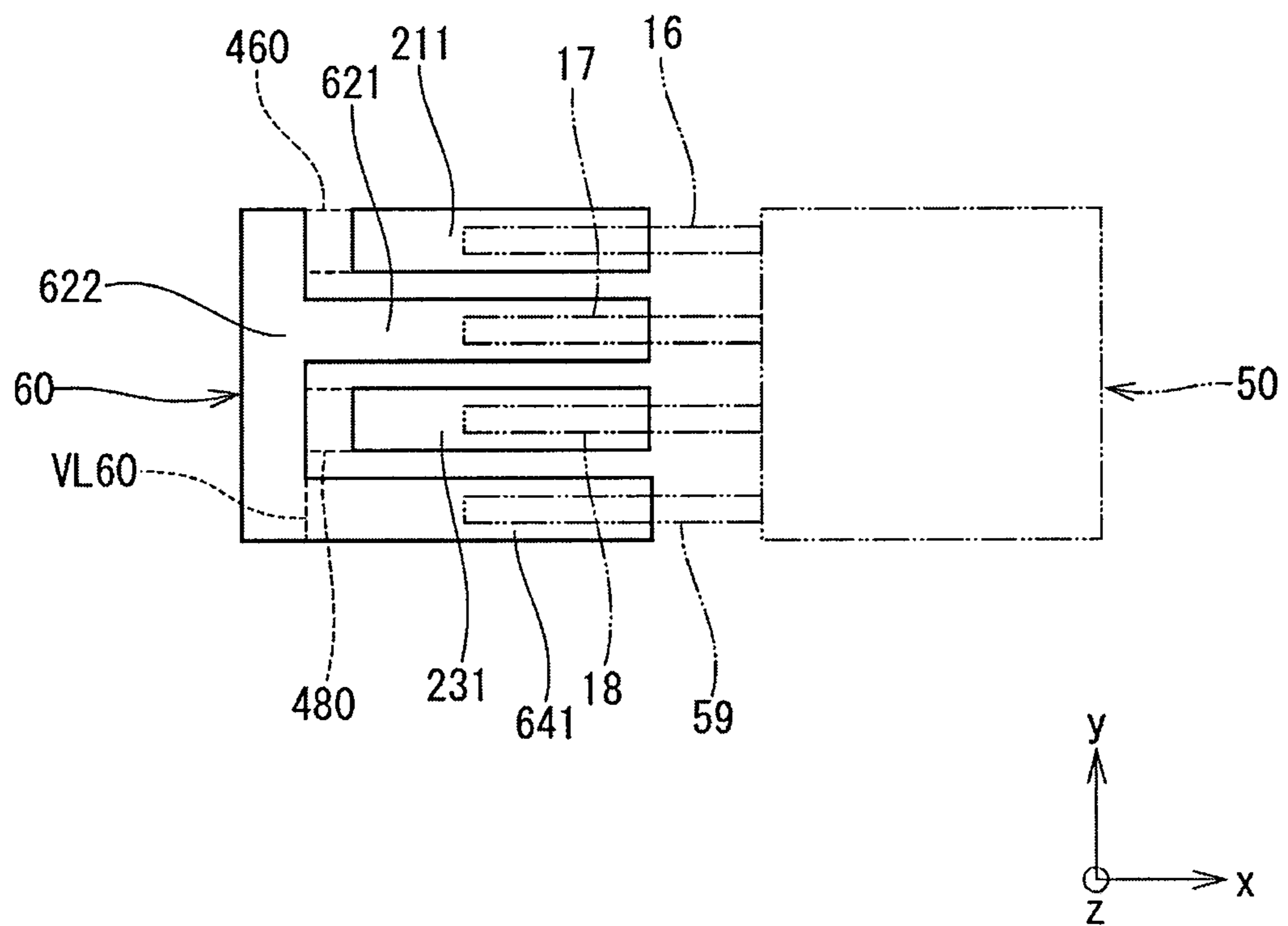

FIG. 8

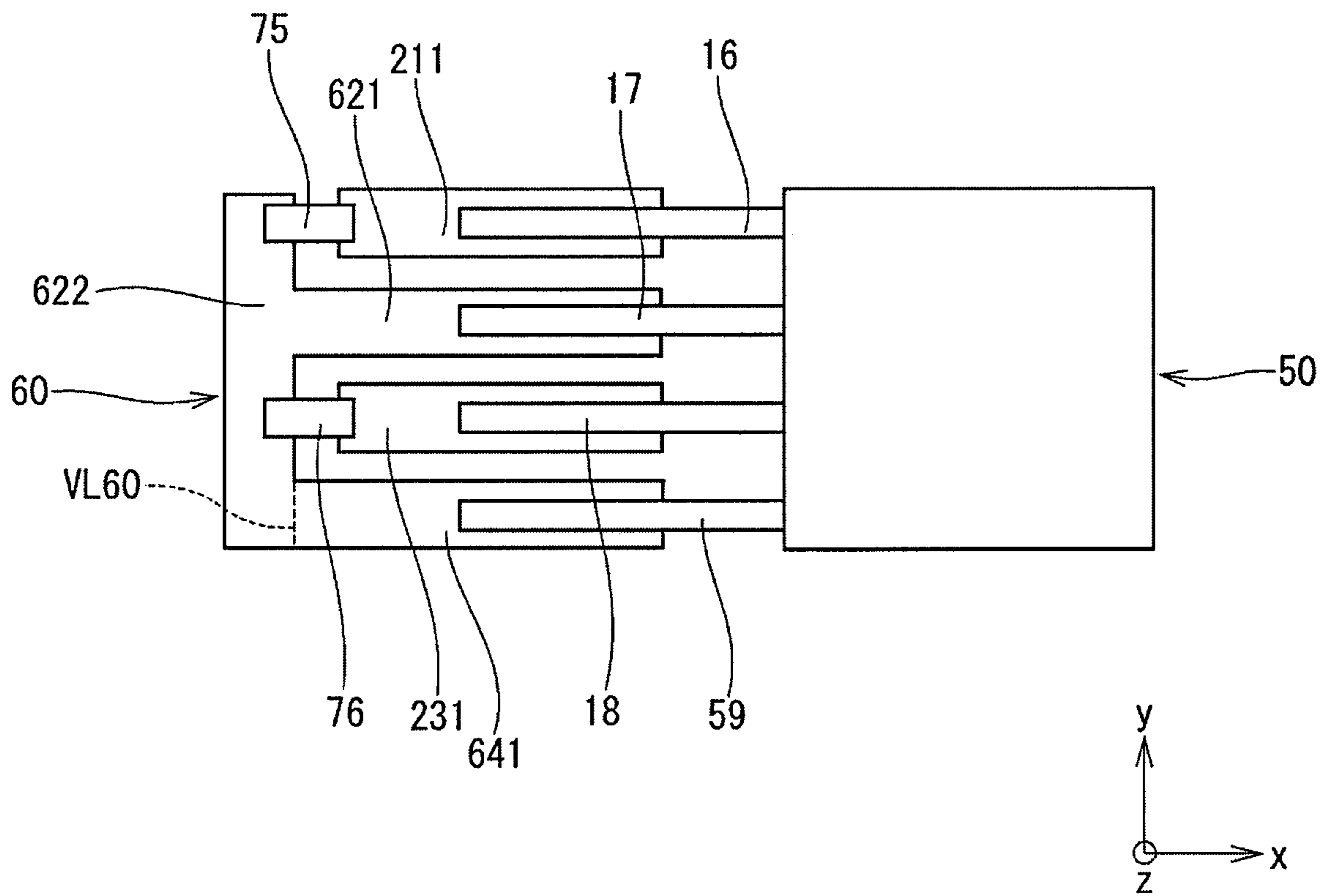

FIG. 9

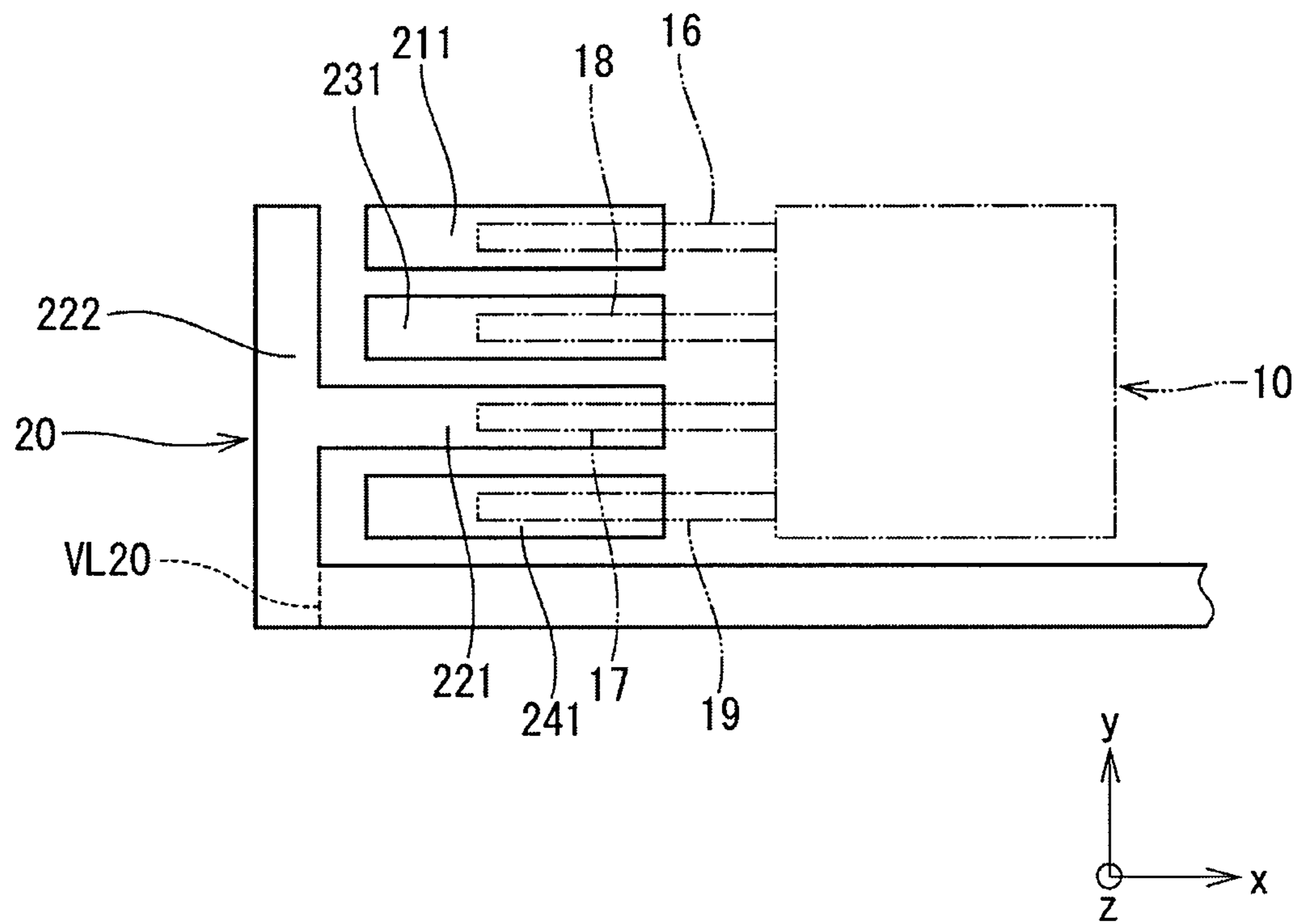
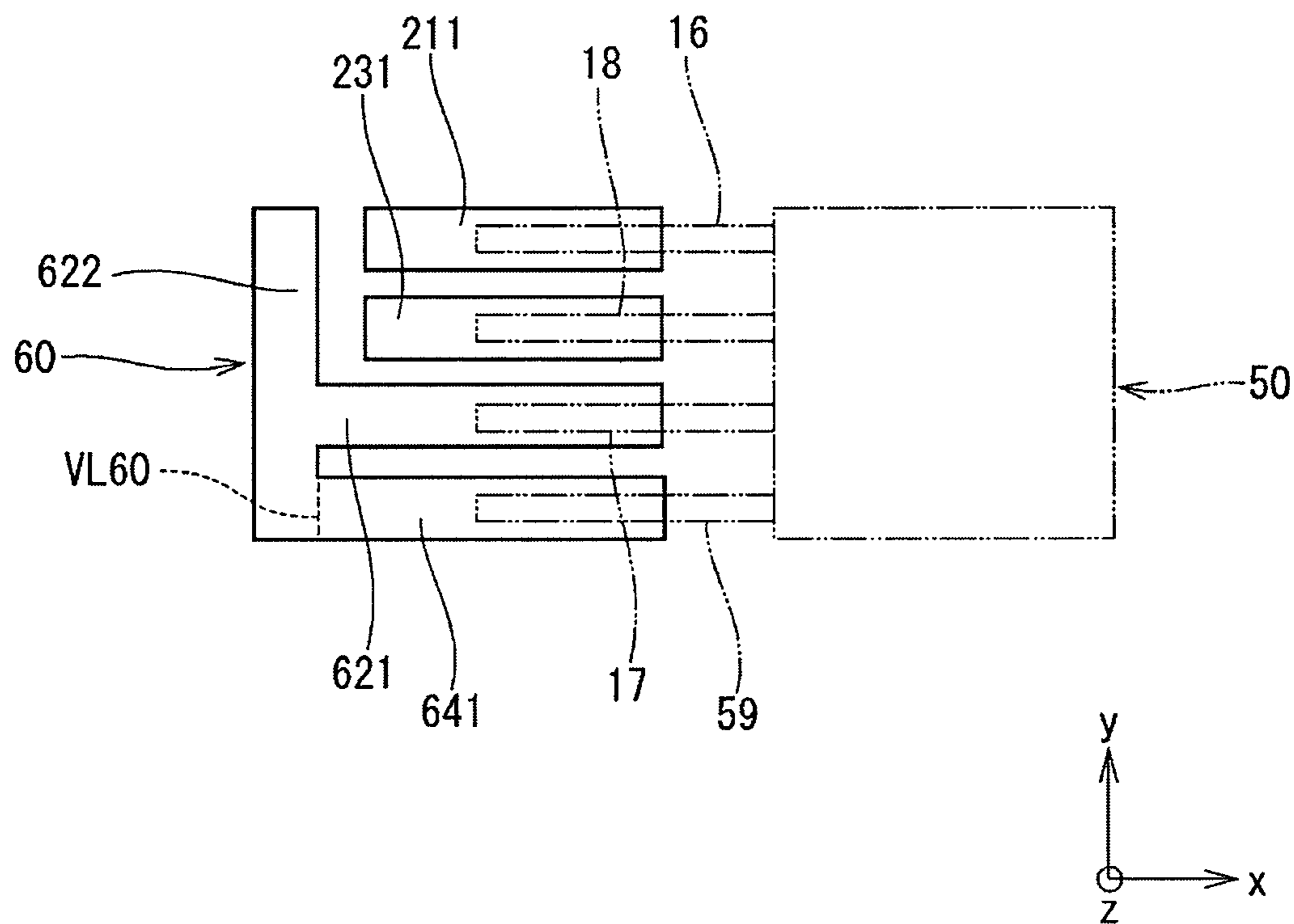

FIG. 10



1**POSITION DETECTING DEVICE, AND
METHOD OF MANUFACTURING POSITION
DETECTING DEVICE****CROSS REFERENCE TO RELATED
APPLICATION**

The present application is a continuation application of International Patent Application No. PCT/JP2017/029300 filed on Aug. 14, 2017, which designated the U.S. and claims the benefit of priority from Japanese Patent Applications No. 2016-162956 filed on Aug. 23, 2016 and No. 2017-106790 filed on May 30, 2017. The entire disclosures of all of the above applications are incorporated herein by reference.

TECHNICAL FIELD

The present disclosure relates to a position detecting device and a method of manufacturing the position detecting device.

BACKGROUND

Conventionally, a position detecting device is used for detecting the position of an object such as a rotational axis of a movable body.

SUMMARY

According to an aspect of the present disclosure, a position detecting device includes a detector to detect an intensity relevant to a magnetic field. The detector is connected with lead lines. The lead lines are further connected to a connector via terminal lines.

BRIEF DESCRIPTION OF THE DRAWINGS

The above and other objects, features and advantages of the present disclosure will become more apparent from the following detailed description made with reference to the accompanying drawings. In the drawings:

The above and other objects, features and advantages of the present disclosure will become more apparent from the following detailed description made with reference to the accompanying drawings. In the drawings:

FIG. 1 is a schematic view illustrating an electronic control throttle device to which a position detecting device according to a first embodiment of the present disclosure is applied;

FIG. 2 is a schematic view illustrating the position detecting device according to the first embodiment of the present disclosure;

FIG. 3A is a schematic view for describing a method of manufacturing the position detecting device according to the first embodiment of the present disclosure;

FIG. 3B is a schematic view different from FIG. 3A for describing a method of manufacturing the position detecting device according to the first embodiment of the present disclosure;

FIG. 4A is a schematic view for describing effects of the position detecting device according to the first embodiment of the present disclosure;

FIG. 4B is a schematic view for describing a position detecting device according to a comparative example;

FIG. 5 is a schematic view illustrating a position detecting device according to a second embodiment of the present disclosure;

2

FIG. 6 is a schematic view illustrating an electronic control throttle device to which a position detecting device according to a third embodiment of the present disclosure is applied;

FIG. 7A is a schematic view illustrating the position detecting device according to the third embodiment of the present disclosure;

FIG. 7B is a schematic view illustrating the position detecting device according to the third embodiment of the present disclosure;

FIG. 8 is a schematic view illustrating a position detecting device according to a fourth embodiment of the present disclosure;

FIG. 9 is a schematic view illustrating a position detecting device according to another embodiment of the present disclosure; and

FIG. 10 is a schematic view illustrating a position detecting device according to another embodiment of the present disclosure.

DETAILED DESCRIPTION

To begin with, an exemplified configuration of a position detecting device will be described as follows.

The position detecting device is configured to detect the position of a detection target. The position detecting device includes an IC package. In a conceivable configuration, the position detecting device may include two magnetic detection elements to detect variation in a magnetic field caused by movement of the detection target. The IC package is electrically connected with a sensor terminal. A motor terminal is further provided to supply electric power to a motor. A connector portion is further provided to enable external terminals to electrically connect with the sensor terminal and the motor terminal.

In the position detecting device as exemplified, the sensor terminal may have two signal terminal lines configured to electrically connect to the two magnetic detection elements respectively, a power supply terminal line common for the two magnetic detection elements, and a ground terminal line common for the two magnetic detection elements. Further, in a conceivable configuration of the position detecting device, one of the two signal terminal lines, the ground terminal line, the power supply terminal line or the other of the two signal terminal lines may be arranged in this order. In the conceivable configuration, the motor terminal is provided adjacently to one of the two signal terminal lines in the connector portion. Consequently, a short circuit would occur between the motor terminal and the signal terminal line. In addition, a current flowing through the motor terminal could cause a magnetic field around the motor terminal. Consequently, signals passing through the signal terminal lines may contain noise. Those issues would exert effect on the detection accuracy of the position of the detection target by using the position detecting device.

In consideration of those issues, a position detecting device may be configured to avoid occurrence of a short circuit between terminals.

In an example, a position detecting device comprises an IC package, a first terminal line, a ground terminal line, a power supply terminal line, a second terminal line, a bypass terminal line, motor terminal lines, and a connector portion. The IC package includes a first magnetic detection element, a second magnetic detection element, a sealing portion, a first lead line, a ground lead line, a power supply lead line, and a second lead line. In the sealing portion, the first magnetic detection element and the second magnetic detec-

3

tion element are sealed. The first lead line, the ground lead line, the power supply lead line, and the second lead line project in a first direction from the sealing portion. The ground lead line and the power supply lead line are provided between the first lead line and the second lead line. The first terminal line extends in a direction opposite to the first direction from a first connection portion electrically connectable to the first lead line. The ground terminal line includes a ground connection portion, which is electrically connectable to the ground lead line, and a bypass portion, which extends in a direction different from the first direction. The bypass portion is connected to an end of the ground connection portion in the first direction. The power supply terminal line extends in the direction opposite to the first direction from a power supply connection portion electrically connectable to the power supply lead line. The second terminal line extends in the direction opposite to the first direction from a second connection portion electrically connectable to the second lead line. The bypass terminal line is positioned on an opposite side of the ground terminal line across the first terminal line or the second terminal line and connected to the bypass portion. The motor terminal lines has one end portions electrically connected to a motor to supply electric power therethrough to the motor to rotate the detection target. In the connector portion, other end portions of the motor terminal line, an end portion of the bypass terminal line opposite to a side connected to the bypass portion, an end portion of the second terminal line opposite to the second connection portion, an end portion of the power supply terminal line opposite to the power supply connection portion, and an end portion of the first terminal line opposite to the first connection portion are placed in this order.

This example enables to arrange the four terminal lines in the connector portion in the order of the bypass terminal line connected to the ground terminal line, the second terminal line, the power supply terminal line, and the first terminal line. Accordingly, the bypass terminal line is enabled to be arranged adjacently to the motor terminal line when the four terminal lines and the motor terminal line are arranged in the connector portion. Thus, this example could restrict a short circuit between terminals in the connector portion. In addition, in this example, the first terminal line and the second terminal line can be provided in positions relatively distant from the motor terminal line. This example could enable to reduce a noise presumably contained in signals flowing through the first terminal line and the second terminal line into a relatively small level even when a magnetic field is formed by the a current flowing through the motor terminal line. Accordingly, this example could enhance the detection accuracy of the position of the detection target.

In another example, a method of manufacturing the position detecting device includes a terminal original form forming process (such as molding) and a cutting process. The terminal original form forming process includes integrally forming, as an original form of a sensor terminal, a portion that is to become the first connection portion of the first terminal line, a portion that is to become the ground connection portion of the ground terminal line, a portion that is to become the power supply connection portion of the power supply terminal line, a portion that is to become the second connection portion of the second terminal line, a portion that is to become the bypass terminal line, and a die bar, such that the die bar is connected to, on a side of the portion that is to become the ground connection portion in the first direction, the portion that is to become the first connection portion, the portion that is to become the ground

4

connection portion, the portion that is to become the power supply connection portion, the portion that is to become the second connection portion, and the portion that is to become the bypass terminal line. The cutting process after the terminal original form forming process includes cutting off, the portion that is to become the first connection portion from the die bar, the portion that is to become the power supply connection portion from the die bar, and the portion that is to become the second connection portion from the die bar.

According to the method of this example, when the original form of the sensor terminal is machined into the sensor terminal, the ground connection portion is kept connected to the die bar and the bypass terminal line is kept connected to the die bar, while the portion that is to become the first connection portion is cut off from the die bar, the portion that is to become the power supply connection portion is cut off from the die bar, and the portion that is to become the second connection portion is cut off from the die bar. This example could facilitate to form the connector portion in which the bypass terminal line electrically connected to the ground lead line is arranged adjacently to the motor terminal line.

In another example, a position detecting device includes an IC package, a signal terminal line, a ground terminal line, a power supply terminal line, a dummy terminal line, motor terminal lines, and a connector portion. The IC package includes a magnetic detection element, a sealing portion, a signal lead line, a ground lead line, a power supply lead line, and a dummy lead line. The dummy lead line projects in the first direction from the sealing portion. The dummy lead line is not electrically connected to the magnetic detection element. The ground lead line and the power supply lead line are provided between the signal lead line and the dummy lead line. The ground terminal line includes a ground connection portion electrically connectable to the ground lead line and a bypass portion extending in a direction different from the first direction and connected to an end of the ground connection portion in the first direction. The dummy terminal line is provided on an opposite side of the signal terminal line across the ground terminal line and extending in the direction opposite to the first direction from a dummy connection portion connectable to the bypass portion and the dummy lead line. In the connector portion, other end portions of the motor terminal lines, an end portion of the dummy terminal line opposite to a side connected to the bypass portion, one of an end portion of the power supply terminal line opposite to a side connected to the power supply connection portion and an end portion of the ground terminal line opposite to a side connected to the bypass portion, the other of the end portion of the power supply terminal line opposite to the side connected to the power supply connection portion and the end portion of the ground terminal line opposite to the side connected to the bypass portion, and an end portion of the signal terminal line opposite to a side connected to the signal connection portion are placed in this order.

According to this example, the bypass portion of the ground terminal line is connected to the dummy terminal line provided on the opposite side of the signal terminal line across the ground terminal line. This example enables to arrange the ground terminal line electrically connected to the ground lead line adjacently to the motor terminal line in the connector portion. Thus, this example could enable to restrict occurrence of a short circuit between terminals in the connector portion. In addition, in this example, the signal terminal line is provided in a position relatively distant from

the motor terminal line. Therefore, this example could enable to reduce a noise contained in a signal flowing through the signal terminal line to a relatively small level. Accordingly, this example could enhance the detection accuracy of the position of the detection target.

In another example, a method of manufacturing the position detecting device includes a terminal original form forming process (such as molding) and a cutting process. The terminal original form forming process includes integrally molding, as an original form of a sensor terminal, a portion that is to become the signal connection portion of the signal terminal line, a portion that is to become the ground connection portion of the ground terminal line, a portion that is to become the power supply connection portion of the power supply terminal line, a portion that is to become the dummy connection portion of the dummy terminal line, and a die bar, such that the die bar is connected to, on one side of the portion that is to become the ground connection portion in the first direction, the portion that is to become the signal connection portion, the portion that is to become the ground connection portion, the portion that is to become the power supply connection portion, and the portion that is to become the dummy connection portion. The cutting process after the terminal original form forming process includes cutting off the portion that is to become the signal connection portion from the die bar and the portion that is to become the power supply connection portion from the die bar.

According to the method of this example, when the original form of the sensor terminal is machined into the sensor terminal, the ground connection portion is kept connected to the die bar and the dummy terminal line is kept connected to the die bar while the portion that is to become the signal connection portion is cut off from the die bar and the portion that is to become the power supply connection portion is cut off from the die bar. This example could facilitate to form the connector portion in which the dummy terminal line electrically connected to the ground lead line is enabled to be arranged adjacently to the motor terminal line.

Embodiments of the present disclosure will be described below with reference to the drawings. Substantially the same components of embodiments are given the same reference numerals and descriptions thereof are omitted.

First Embodiment

A position detecting device according to a first embodiment will be described with reference to FIGS. 1, 2, 3, 4A, and 4B. A rotation angle detecting device 1, which is “the position detecting device” according to the first embodiment, is used in an electronic control throttle device 80 that controls the amount of intake air supplied to an engine installed in a vehicle (not illustrated).

First, the structure of the electronic control throttle device 80 will be described. As illustrated in FIG. 1, the electronic control throttle device 80 includes a valve housing 81, a throttle valve 82, a motor 83, the rotation angle detecting device 1, an electronic control unit (referred to below as the ECU) 84, and the like.

The valve housing 81 includes an intake air passage 810 through which air is introduced to the engine. The throttle valve 82 is provided in the intake air passage 810.

The throttle valve 82 includes the valve member 821 and a valve shaft 822 as “detection targets”.

The valve member 821 is a substantially disk-shaped member having an outer diameter slightly smaller than the

inner diameter of the intake air passage 810. The valve member 821 is fixed to the valve shaft 822.

Both sides of the valve shaft 822 are rotatably supported by the valve housing 81. This causes the valve member 821 to rotate about a rotation shaft CA1 of the valve shaft 822 as a rotation shaft. A magnet 823 is provided in an end portion of the valve shaft 822 close to the rotation angle detecting device 1. When the valve shaft 822 rotates, a magnetic field in the vicinity of an IC package 10 included in the rotation angle detecting device 1 changes.

The motor 83 is accommodated in the rotation angle detecting device 1. The motor 83 is coupled to the valve shaft 822 via a coupling member 831. The motor 83 generates a rotational torque to rotate the valve shaft 822. The motor 83 is electrically connected to the ECU 84.

The ECU 84 is a small computer including a CPU as computation unit, a ROM and a RAM as storage unit, input-output unit, and the like. The ECU 84 determines the opening of the throttle valve 82 according to the travel state of the vehicle in which the electronic control throttle device 80 is installed and the operational state of the driver of the vehicle. The ECU 84 outputs electric power to the motor 83 according to the opening of the throttle valve 82. This controls the opening of the throttle valve 82 and adjusts the amount of intake air supplied to the engine.

The rotation angle detecting device 1 includes the IC package 10, a sensor terminal 20, a motor terminal 27, and a sensor housing 30, which is “the housing”. The rotation angle detecting device 1 is provided in the part of the valve housing 81 close to the end portion of the valve shaft 822 in which the magnet 823 is provided. FIG. 2 represents the sensor housing 30 using a dotted line and schematically illustrates the shapes and the disposition of the IC package 10, the sensor terminal 20, and the motor terminal 27.

The IC package 10 is an IC package referred to as two-system output type or two-output type and includes a first magnetic detection element 11, a first signal processing circuit 110, a second magnetic detection element 12, a second signal processing circuit 120, a sealing portion 13, a first lead line 16, a ground lead line 17, a power supply lead line 18, and a second lead line 19. The IC package 10 is provided in the vicinity of the magnet 823 on the rotation shaft CA1, as illustrated in FIG. 1.

The first magnetic detection element 11 is configured to output a first signal that depends on a first component of the magnetic field formed by the magnet 823 or the strength of the first component. The first magnetic detection element 11 is electrically connected to the power supply lead line 18, the ground lead line 17, and the first signal processing circuit 110.

The first signal processing circuit 110 is electrically connected to the first lead line 16. The first signal processing circuit 110 processes the first signal output by the first magnetic detection element 11.

The second magnetic detection element 12 is configured to output a second signal that depends on a second component different from the first component of the magnetic field formed by the magnet 823 or the strength of the second component. The second magnetic detection element 12 is electrically connected to the power supply lead line 18, the ground lead line 17, and the second signal processing circuit 120.

The second signal processing circuit 120 is electrically connected to the second lead line 19. The second signal processing circuit 120 processes the second signal output by the second magnetic detection element 12.

The sealing portion **13** is used to seal the first magnetic detection element **11**, the first signal processing circuit **110**, the second magnetic detection element **12**, and the second signal processing circuit **120** and formed in a substantially rectangular parallelepiped.

The first lead line **16** is formed so as to project in a direction substantially orthogonal to the rotation shaft **CA1** from a surface **131** of the sealing portion **13**. The first signal output by the first signal processing circuit **110** is configured to be output to the outside through the first lead line **16**.

A coordinate plane is set in FIG. 2 to conveniently describe the shapes and disposition of the IC package **10**, the sensor terminal **20**, and the motor terminal **27**. The axis parallel with the direction in which the first lead line **16** projects is defined to be the x-axis and the direction in which the first lead line **16** projects is defined to be the negative direction of the x-axis. That is, the first lead line **16** projects in the negative direction of the x-axis, which is “the first direction”, from the surface **131**. In addition, the axis orthogonal to the x-axis and the rotation shaft **CA1** is defined to be the y-axis. In addition, the axis orthogonal to the x-axis and the y-axis is defined to be the z-axis.

The ground lead line **17** is formed so as to project in the negative direction of the x-axis from the surface **131** of the sealing portion **13**. A current that has flowed through the first magnetic detection element **11** and the second magnetic detection element **12** flows to the ground through the ground lead line **17**.

The power supply lead line **18** is formed so as to project in the negative direction of the x-axis from the surface **131** of the sealing portion **13**. The current toward the first magnetic detection element **11** and the second magnetic detection element **12** from a power supply (not illustrated) flows through the power supply lead line **18**.

The second lead line **19** is formed so as to project in the negative direction of the x-axis from the surface **131** of the sealing portion **13**. The second signal output by the second signal processing circuit **120** is configured to be output to the outside through the second lead line **19**.

In the IC package **10** according to the first embodiment, the first lead line **16**, the ground lead line **17**, the power supply lead line **18**, and the second lead line **19** are arranged in this order from the positive side to the negative side of the y-axis so as to project in the negative direction of the x-axis.

The sensor terminal **20** includes a first terminal line **21**, a ground terminal line **22**, a power supply terminal line **23**, a second terminal line **24**, and a bypass terminal line **25**. The sensor terminal **20**, which is a member having a relatively large conductivity, is formed so as to extend from the vicinity of the first lead line **16** or the like to a connector portion **31** of the sensor housing **30** through the opposite side of the magnet **823** of the IC package **10**. The sensor terminal **20** is formed integrally with the sensor housing **30** by insert molding of the sensor housing **30** (see FIG. 1).

The first terminal line **21** includes a first welding terminal **211**, which is “the first connection portion”, a first insert portion **212**, and a first connector terminal **213**, which is “the end portion of the first terminal line opposite to the first connection portion”.

The first welding terminal **211** is provided in a position in which welding to the first lead line **16** is enabled. The first welding terminal **211** is formed so as to extend in the positive direction of the x-axis, which is “the direction opposite to the first direction”, from the tail end of the first terminal line **21**. The side of the first welding terminal **211** opposite to the tail end of the first terminal line **21** is connected to the first insert portion **212**.

The first insert portion **212** is inserted into the sensor housing **30**. The first insert portion **212** is formed so as to extend in the positive direction of the y-axis through the opposite side of the magnet **823** of the IC package **10** and then extend in the negative direction of the x-axis. The side of the first insert portion **212** opposite to the side connected to the first welding terminal **211** is connected to the first connector terminal **213**.

The first connector terminal **213** is positioned in the connector portion **31**. The first connector terminal **213** is formed so as to be electrically connectable to the ECU **84** via an external connector. The first terminal line **21** outputs the first signal that has been output by the first signal processing circuit **110** to the ECU **84**.

The ground terminal line **22** includes a ground welding terminal **221**, which is “the ground connection portion”, and a bypass portion **222**.

The ground welding terminal **221** is provided in a position in which welding to the ground lead line **17** is enabled. The ground welding terminal **221** is formed so as to extend in the negative direction of the x-axis from the tail end of the ground terminal line **22**. That is, the ground welding terminal **221** is formed so as to extend in a direction opposite to the first welding terminal **211**. The side of the ground welding terminal **221** opposite to the tail end of the ground terminal line **22** is connected to the bypass portion **222**.

The bypass portion **222** is formed so as to extend in the y-direction, which is “the direction different from the first direction”. The bypass portion **222** is positioned in the negative direction of the x-axis with respect to the first welding terminal **211**, the ground welding terminal **221**, a power supply welding terminal **231** of the power supply terminal line **23**, and a second welding terminal **241** of the second terminal line **24**. The bypass portion **222** is connected to the ground welding terminal **221** on the positive side of the x-axis. The end portion of the bypass portion **222** positioned in the negative direction of the y-axis is connected to the bypass terminal line **25**.

The power supply terminal line **23** includes the power supply welding terminal **231**, which is “the power supply connection portion”, a power supply insert portion **232**, and a power supply connector terminal **233**, which is “the end portion of the power supply terminal line opposite to the power supply connection portion”.

The power supply welding terminal **231** is provided in a position in which welding to the power supply lead line **18** is enabled. The power supply welding terminal **231** is formed so as to extend in the positive direction of the x-axis from the tail end of the power supply terminal line **23**. The side of the power supply welding terminal **231** opposite to the tail end of the power supply terminal line **23** is connected to the power supply insert portion **232**.

The power supply insert portion **232** is inserted into the sensor housing **30**. The power supply insert portion **232** is formed so as to extend in the positive direction of the y-axis through the opposite side of the magnet **823** of the IC package **10** and then extend in the negative direction of the x-axis. The side of the power supply insert portion **232** opposite to the side connected to the power supply welding terminal **231** is connected to the power supply connector terminal **233**.

The power supply connector terminal **233** is positioned in the connector portion **31**. The power supply connector terminal **233** is formed so as to be electrically connectable to a power supply (not illustrated) via an external connector (not illustrated). The current toward the first magnetic detec-

tion element **11** and the second magnetic detection element **12** from the power supply flows through the power supply terminal line **23**.

The second terminal line **24** includes the second welding terminal **241**, which is “the second connection portion”, a second insert portion **242**, and a second connector terminal **243**, which is “the end portion of the second terminal line opposite to the second connection portion”.

The second welding terminal **241** is provided in a position in which welding to the second lead line **19** is enabled. The second welding terminal **241** is formed so as to extend in the positive direction of the x-axis from the tail end of the second terminal line **24**. The side of the second welding terminal **241** opposite to the tail end of the second terminal line **24** is connected to the second insert portion **242**.

The second insert portion **242** is inserted into the sensor housing **30**. The second insert portion **242** is formed so as to extend in the positive direction of the y-axis through the opposite side of the magnet **823** of the IC package **10** and then extend in the negative direction of the x-axis. The side of the second insert portion **242** opposite to the side connected to the second welding terminal **241** is connected to the second connector terminal **243**.

The second connector terminal **243** is positioned in the connector portion **31**. The second connector terminal **243** is formed so as to be electrically connectable to the ECU **84** via an external connector. The second terminal line **24** outputs the second signal output by the second signal processing circuit **120** to the ECU **84**.

The bypass terminal line **25** includes a bypass connection portion **251**, a bypass insert portion **252**, and a bypass terminal **253**, which is “the end portion of the bypass terminal line opposite to the side connected to the bypass portion”.

As illustrated in FIG. 2, the bypass connection portion **251** is positioned in the negative direction of the y-axis with respect to the second welding terminal **241** of the second terminal line **24**. That is, the bypass connection portion **251** is positioned on the opposite side of the ground terminal line **22** with respect to the second terminal line **24**. The side of the bypass connection portion **251** opposite to the side connected to the bypass portion **222** is connected to the bypass insert portion **252**. In FIG. 2, the virtual boundary line between the bypass portion **222** and the bypass connection portion **251** is represented by a dotted line VL20.

The bypass insert portion **252** is inserted into the sensor housing **30**. The bypass insert portion **252** is formed so as to extend in the positive direction of the y-axis through the opposite side of the magnet **823** of the IC package **10** and then extend in the negative direction of the x-axis. The side of the bypass insert portion **252** opposite to the side connected to the bypass connection portion **251** is connected to the bypass terminal **253**.

The bypass terminal **253** is positioned in the connector portion **31**. The bypass terminal **253** is formed so as to be electrically connectable to the ground via an external connector. This connects the ground lead line **17** to the ground via the ground welding terminal **221**, the bypass portion **222** of the ground terminal line **22**, the bypass connection portion **251**, the bypass insert portion **252**, and the bypass terminal **253** of the bypass terminal line **25**.

The motor terminal **27** includes two motor terminal lines **28** and **29**. The two motor terminal lines **28** and **29** have motor connection terminals **281** and **291**, which are “one end portions of the motor terminal lines”, motor insert portions

282 and **292**, and motor connector terminals **283** and **293**, which are “the other end portions of the motor terminal lines”, respectively.

The motor connection terminals **281** and **291** are provided in sockets **33** and **34** of the sensor housing **30**. The sockets **33** and **34** are formed so as to engage with the motor **83**. This enables the motor connection terminals **281** and **291** to be connected to external terminals (not illustrated) of the motor **83**. The motor connection terminals **281** and **291** are connected to the motor insert portions **282** and **292**.

The motor insert portions **282** and **292** are inserted into the sensor housing **30**. The end portions of the motor insert portions **282** and **292** opposite to the sides connected to the motor connection terminals **281** and **291** are connected to the motor connector terminals **283** and **293**.

The motor connector terminals **283** and **293** are positioned in the connector portion **31**. The motor terminal **27** can supply electric power supplied by the power supply to the motor **83** via the connector portion **31**.

The sensor housing **30** is a hollow member formed in a substantially rectangular parallelepiped and has the length in the x-direction shorter than the length in the y-direction, as illustrated in FIG. 2. The part of the sensor housing **30** close to the valve housing **81** has an opening as illustrated in FIG. 1 so as to accommodate the motor **83** therein. The sensor housing **30** is fixed to the valve housing **81** through a bolt **301** so as to disable relative movement. The sensor housing **30** has a stage **32** on which the IC package **10** can be mounted (see FIG. 1). This enables the IC package **10** to be provided in the vicinity of the magnet **823**. A part of the sensor terminal **20** is inserted into the stage **32**.

Next, the method of manufacturing the rotation angle detecting device **1** will be described with reference to FIG. 3A and FIG. 3B.

First, the original form of the sensor terminal **20** and the original form of the motor terminal **27** are formed by, for example, press work of a metal plate, which is “the terminal original form forming process”. At this time, the original form of the sensor terminal **20** has a die bar to which the original form of the first terminal line **21**, the original form of the ground terminal line **22**, the original form of the power supply terminal line **23**, the original form of the second terminal line **24**, and the original form of the bypass terminal line **25** are connected. In addition, the original form of the motor terminal **27** has a die bar to which the original forms of the two motor terminal lines **28** and **29** are connected.

FIG. 3A is a partial enlarged view illustrating an original form **40** of the sensor terminal **20**. In FIG. 3A, the IC package **10** to be connected to the sensor terminal **20** is represented by a dot-dot-dash line.

In the original form **40** of the sensor terminal **20**, a portion **411** that is to become the first welding terminal **211**, a portion **421** that is to become the ground welding terminal **221**, a portion **431** that is to become the power supply welding terminal **231**, a portion **441** that is to become the second welding terminal **241**, and a portion **451** that is to become the bypass terminal line **25** are connected via a die bar **422** that is to become the bypass portion **222**.

Next, the sensor housing **30** into which the sensor terminal **20** and the motor terminal **27** have been inserted is molded as “a cutting process”. FIG. 3B is a partial enlarged view illustrating the original form **40** of the sensor terminal **20** used to mold the sensor housing **30**. In FIG. 3B, the IC package **10** to be connected to the sensor terminal **20** is represented by a dot-dot-dash line.

When the sensor housing **30** is molded, in the original form **40** of the sensor terminal **20**, the portion **421** is kept

11

connected to the die bar 422 while the portion 411 is cut off from the die bar 422, the portion 431 is cut off from the die bar 422, and the portion 441 is cut off from the die bar 422. In FIG. 3B, the portions that have been cut off at this time are represented by dotted lines 410, 430, and 440. The sensor terminal 20 formed by cutting off the portions 411, 431, and 441 from the die bar 422 and the motor terminal lines 28 and 29 from which the die bar has been cut off are set in a metal mold and then resin is injected into the metal mold to mold the sensor housing 30.

Finally, the IC package 10 that has been manufactured separately is mounted on the stage 32 of the sensor housing 30 and the first welding terminal 211 whose original form is the portion 411 is electrically connected to the first lead line 16, the ground welding terminal 221 whose original form is the portion 421 is electrically connected to the ground lead line 17, the power supply welding terminal 231 whose original form is the portion 431 is electrically connected to the power supply lead line 18, and the second welding terminal 241 whose original form is the portion 441 is electrically connected to the second lead line 19 by welding or the like.

This brings the rotation angle detecting device 1 to completion.

Next, the effects of the rotation angle detecting device 1 will be described with reference to FIG. 4A and FIG. 4B.

(A) FIG. 4A illustrates the positional relationship between the first lead line 16, the ground lead line 17, the power supply lead line 18, and the second lead line 19 and the first terminal line 21, the ground terminal line 22, the power supply terminal line 23, and the second terminal line 24 in the rotation angle detecting device 1 according to the first embodiment. In addition, FIG. 4B illustrates the positional relationship between a first lead line 96, a ground lead line 97, a power supply lead line 98, and a second lead line 99 and a first terminal line 91, a ground terminal line 92, a power supply terminal line 93, and a second terminal line 94 in a rotation angle detecting device 90 according to the comparative example. In the rotation angle detecting device 90 according to the comparative example, unlike the rotation angle detecting device 1, the portion of the ground terminal line 92 welded to the ground lead line 97 is formed so as to extend in the positive direction of the x-axis.

In the rotation angle detecting device 90 according to the comparative example, in a case where a sensor terminal 95 extends from the vicinity of the power supply lead line 98 or the like to a connector portion 901, the first terminal line 91, the ground terminal line 92, the power supply terminal line 93, and the second terminal line 94 are arranged in this order in the connector portion 901 as illustrated in FIG. 4B. Accordingly, since the second terminal line 94 is positioned adjacently to a motor terminal 902 of the rotation angle detecting device 90, a short circuit would occur between the motor terminal 902 and the second terminal line 94 in the rotation angle detecting device 90 according to the comparative example.

On the other hand, in the rotation angle detecting device 1 according to the first embodiment, the ground terminal line 22 connected to the ground lead line 17 is connected to the bypass terminal line 25 positioned on the opposite side of the ground terminal line 22 across the second terminal line 24. Accordingly, in the connector portion 31, the bypass terminal 253 of the bypass terminal line 25 electrically connected to the ground terminal line 22 is arranged adjacently to the motor connector terminals 283 and 293 of the motor terminal lines 28 and 29. This enables to restrict a short circuit between the motor terminal 27 and the sensor terminal 20 in

12

the connector portion 31 as compared with the case in which the second connector terminal 243 and the like are arranged adjacently to the motor connector terminals 283 and 293.

(B) In addition, in the rotation angle detecting device 90 according to the comparative example, a current flowing through the motor terminal 902 may cause noise in the second signal passing through the second terminal line 94 adjacent to the motor terminal 902. Accordingly, the rotation angle of the throttle valve 82 cannot be detected accurately.

In the rotation angle detecting device 1 according to the first embodiment, the first terminal line 21 and the second terminal line 24 are provided in positions relatively distant from the motor terminal lines 28 and 29. This enables to reduce noise caused in the first signal and the second signal due to a magnetic field caused by a current flowing through the motor terminal lines 28 and 29. Accordingly, the detection accuracy of the rotation angle of the valve member 821 could be enhanced.

(C) In addition, in the rotation angle detecting device 1 according to the first embodiment, the ground terminal line 22 does not need to be routed along the rotation shaft CA1 with respect to the first terminal line 21, the power supply terminal line 23, and the second terminal line 24 to obtain the effects (A) and (B) described above. This restricts the size of the rotation angle detecting device 1 from becoming large.

(D) In the method of manufacturing the rotation angle detecting device 1 according to the first embodiment, when the original form 40 of the sensor terminal 20 is used as the sensor terminal 20, the die bar 422 kept connected to the portion 421 that is to become the ground welding terminal 221 and the portion 451 that is to become the bypass terminal line 25 is used as the bypass portion 222 of the ground terminal line 22 while the portion 411 that is to become the first welding terminal 211 is cut off from the die bar 422, the portion 431 that is to become the power supply welding terminal 231 is cut off from the die bar 422, and the portion 441 that is to become the second welding terminal 241 is cut off from the die bar 422. This facilitates to form the connector portion 31 in which the bypass terminal line 25 electrically connected to the ground terminal line 22 is enabled to be arranged adjacently to the motor terminal 27.

Second Embodiment

A position detecting device according to a second embodiment will be described with reference to FIG. 5. The second embodiment is different from the first embodiment in that capacitors are provided.

A rotation angle detecting device according to the second embodiment includes the IC package 10, the sensor terminal 20, the motor terminal 27, capacitors 35, 36, 37, and the sensor housing 30.

The capacitors 35, 36, and 37 are provided in the IC package 10.

The capacitor 35 is provided so as to connect the first welding terminal 211 and the bypass portion 222 in a direction along the x-axis.

The capacitor 36 is provided so as to connect the power supply welding terminal 231 and the bypass portion 222 in a direction along the x-axis.

The capacitor 37 is provided so as to connect the second welding terminal 241 and the bypass portion 222 in a direction along the x-axis.

Since a capacitor (not illustrated) sealed by the sealing portion 13 together with the first magnetic detection element 11, the first signal processing circuit 110, the second mag-

13

netic detection element 12, and the second signal processing circuit 120 is restricted in size to reduce the size of the IC package 10, it is difficult to obtain a certain level of EMC resistance.

Accordingly, in the rotation angle detecting device according to the second embodiment, noise can be reduced by providing the external capacitors 35 and 36, 37 between the first welding terminal 211 and the bypass portion 222, between the power supply welding terminal 231 and the bypass portion 222, and between the second welding terminal 241 and the bypass portion 222. Therefore, the second embodiment can obtain the same effects as the first embodiment and improve EMC resistance.

In addition, in the process of manufacturing the rotation angle detecting device according to the second embodiment, the capacitors 35, 36, and 37 can be provided in the regions in which the die bar is cut off. This can easily provide the capacitors 35, 36, and 37 between the IC package 10 and the sensor terminal 20.

In addition, in the rotation angle detecting device according to the second embodiment, the capacitors 35, 36, and 37 are connected in the direction along the x-axis, which is the short direction of the sensor housing 30. This enables to restrict the breakage of the capacitors 35, 36, and 37 when the sensor housing 30 thermally expands because thermal expansion in the short direction is relatively small.

Third Embodiment

A position detecting device according to a third embodiment will be described with reference to FIGS. 6, 7A, and 7B. The third embodiment is different from the first embodiment in the shapes of the IC package and the sensor terminal.

A rotation angle detecting device 3 according to the third embodiment includes an the IC package 50, a sensor terminal 60, the motor terminal 27, and a sensor housing 70, which is “the housing”. The rotation angle detecting device 3 is provided in the part of the valve housing 81 close to the end portion of the valve shaft 822 in which the magnet 823 is provided. FIG. 6 represents the sensor housing 70 using a dotted line and schematically illustrates the shapes and the disposition of the IC package 50, the sensor terminal 60, and the motor terminal 27.

The IC package 50 includes the first magnetic detection element 11, which is “the magnetic detection element”, the first signal processing circuit 110, the sealing portion 13, the first lead line 16, which is “the signal lead line”, the ground lead line 17, the power supply lead line 18, and a dummy lead line 59. The IC package 50 is an IC package that has one magnetic detection element unlike the first embodiment. The IC package 50 is provided in the vicinity of the magnet 823 on the rotation shaft CA1.

The dummy lead line 59 is formed so as to project in the negative direction of the x-axis from the surface 131 of the sealing portion 13. The dummy lead line 59 is not electrically connected to the first magnetic detection element 11 and provided on the opposite side of the ground lead line 17 across the power supply lead line 18.

The sensor terminal 60 includes the first terminal line 21, which is “the signal terminal line” having the first welding terminal 211 as “the signal connection portion” that can be welded to the first lead line 16, the ground terminal line 62, the power supply terminal line 23, and a dummy terminal line 64. The sensor terminal 60, which is a member having a relatively large conductivity, is formed so as to extend from the vicinity of the first lead line 16 or the like to a connector portion 71 of the sensor housing 70 through the

14

opposite side of the magnet 823 of the IC package 50. The sensor terminal 60 is formed integrally with the sensor housing 70 by insert molding of the sensor housing 70.

The ground terminal line 62 includes a ground welding terminal 621, which is “the ground connection portion”, a bypass portion 622, a ground insert portion 620, and a ground connector terminal 623, which is “the end portion of the ground terminal line opposite to the bypass portion”.

The ground welding terminal 621 is provided in a position in which welding to the ground lead line 17 is enabled. The ground welding terminal 621 is formed so as to extend in a direction along the x-axis. The side of the ground welding terminal 621 positioned in the negative direction of the x-axis is connected to the bypass portion 622. The side of the ground welding terminal 621 positioned in the positive direction of the x-axis is connected to the ground insert portion 620.

The bypass portion 622 is formed so as to extend in the y-direction, which is “the direction different from the first direction”. The bypass portion 622 is positioned in the negative direction of the x-axis with respect to the first welding terminal 211, the ground welding terminal 621, the power supply welding terminal 231, and a dummy connection portion 641 of the dummy terminal line 64. The bypass portion 622 is connected to the ground welding terminal 621 and the dummy connection portion 641 on the positive side of the x-axis.

The ground insert portion 620 is inserted into the sensor housing 70. The ground insert portion 620 is formed so as to extend in the positive direction of the y-axis through the opposite side of the magnet 823 of the IC package 50 and then extend in the negative direction of the x-axis. The side of the ground insert portion 620 opposite to the side connected to the ground welding terminal 221 is connected to the ground connector terminal 623.

The ground connector terminal 623 is positioned in the connector portion 71. The ground connector terminal 623 is formed so as to be electrically connectable to the ground via an external connector.

The dummy terminal line 64 includes the dummy connection portion 641, the dummy insert portion 642, and a dummy terminal 643, which is “the end portion of the dummy terminal line opposite to the side connected to the bypass portion”.

The dummy connection portion 641 is provided in a position in which welding to the dummy lead line 59 is enabled. The dummy connection portion 641 is formed so as to extend in a direction along the x-axis. The side of the dummy connection portion 641 positioned in the negative direction of the x-axis is connected to the bypass portion 622. The side of the dummy connection portion 641 positioned in the positive direction of the x-axis is connected to the dummy insert portion 642. In FIG. 6, the virtual boundary line between the bypass portion 622 and the dummy connection portion 641 is represented by a dotted line VL60.

The dummy insert portion 642 is inserted into the sensor housing 70. The dummy insert portion 642 is formed so as to extend in the positive direction of the y-axis through the opposite side of the magnet 823 of the IC package 50 and then extend in the negative direction of the x-axis. The side of the dummy insert portion 642 opposite to the side connected to the dummy connection portion 641 is connected to the dummy terminal 643.

The dummy terminal 643 is positioned in the connector portion 31. The dummy terminal 643 is formed so as to be electrically connectable to the ground via an external connector.

As described above, in the rotation angle detecting device 3, the ground lead line 17 is connected to the ground through two paths. One path passes through the ground welding terminal 621, the ground insert portion 620, and the ground connector terminal 623. The other path passes through the ground welding terminal 621, the bypass portion 622, the dummy connection portion 641, the dummy insert portion 642, and the dummy terminal 643.

Next, the method of manufacturing the rotation angle detecting device 3 will be described with reference to FIG. 7A and FIG. 7B.

First, an original form of the sensor terminal 60 and an original form of the motor terminal 27 are formed by, for example, press work of a metal plate as “the terminal original form forming process”.

FIG. 7A is a partial enlarged view illustrating an original form 45 of the sensor terminal 60. In FIG. 7A, the IC package 50 to be connected to the sensor terminal 60 is represented by a dot-dot-dash line.

In the original form 45 of the sensor terminal 60, a portion 461 that is to become the first welding terminal 211, a portion 471 that is to become the ground welding terminal 621, a portion 481 that is to become the power supply welding terminal 231, a portion 491 that is to become the dummy connection portion 641 are connected by a die bar 472 that is to become the bypass portion 622.

Next, the sensor housing 70 into which the sensor terminal 60 and the motor terminal 27 have been inserted is molded as “the cutting process”. FIG. 7B is a partial enlarged view illustrating the original form 45 of the sensor terminal 60 used to mold the sensor housing 70. In FIG. 7B, the IC package 50 to be connected to the sensor terminal 60 is represented by a dot-dot-dash line.

When the sensor housing 70 is molded, in the original form 45 of the sensor terminal 60, the portion 471 is kept connected to the die bar 472 and the portion 491 is kept connected to the die bar 472 while the portion 461 is cut off from the die bar 472 and the portion 481 is cut off from the die bar 472. In FIG. 7B, the portions that have been cut off at this time are represented by dotted lines 460 and 480. The sensor terminal 60 formed by cutting off the portions 461 and 481 from the die bar 472 and the motor terminal lines 28 and 29 from which the die bar has been cut off are set in a metal mold and then resin is injected into the metal mold to mold the sensor housing 70.

Finally, the IC package 50 that has been manufactured separately is mounted on the stage 32 of the sensor housing 70, the first welding terminal 211 whose original form is the portion 461 is electrically connected to the first lead line 16, the ground welding terminal 621 whose original form is the portion 471 is electrically connected to the ground lead line 17, the power supply welding terminal 231 whose original form is the portion 481 is electrically connected to the power supply lead line 18, and the dummy connection portion 641 whose original form is the portion 491 is electrically connected to the dummy lead line 59 by welding or the like.

This brings the rotation angle detecting device 3 to completion.

In the rotation angle detecting device 3 in the third embodiment, the bypass portion 622 of the ground terminal line 62 is connected to the dummy terminal line 64 provided on the opposite side of the ground terminal line 62 across the power supply terminal line 23. Accordingly, in the connector portion 71, the dummy terminal 643 of the dummy terminal line 64 electrically connected to the ground terminal line 62, the power supply connector terminal 233, and the first connector terminal 213, which is “the end portion of the

signal terminal line opposite to the signal connection portion” are arranged in this order adjacently to the motor connector terminals 283 and 293 of the motor terminal lines 28 and 29. Thus, the third embodiment obtains the effects (A) to (C) of the first embodiment.

In addition, in the method of manufacturing the rotation angle detecting device 3 according to the third embodiment, when the original form 45 of the sensor terminal 60 is used as the sensor terminal 60, the die bar 472 kept connected to the portion 471 that is to become the ground welding terminal 621 and to the portion 481 that is to become the dummy connection portion 641 is used as the bypass portion 622 of the ground terminal line 62 while the portion 461 that is to become the first welding terminal 211 is cut off from the die bar 472 and the portion 481 that is to become the power supply welding terminal 231 is cut off from the die bar 472. This facilitates to form the connector portion 71 in which the dummy terminal line 64 electrically connected to the ground lead line 17 is enabled to be arranged adjacently to the motor terminal line 27.

Fourth Embodiment

A position detecting device according to a fourth embodiment will be described with reference to FIG. 8. The fourth embodiment is different from the third embodiment in that capacitors are provided.

A rotation angle detecting device according to the fourth embodiment includes the IC package 50, the sensor terminal 60, the motor terminal 27, capacitors 75 and 76, and the sensor housing 70.

The capacitors 75 and 76 are provided in the IC package 50.

The capacitor 75 is provided so as to connect the first welding terminal 211 and the bypass portion 622 in a direction along the x-axis.

The capacitor 76 is provided so as to connect the power supply welding terminal 231 and the bypass portion 622 in a direction along the x-axis.

In the rotation angle detecting device according to the fourth embodiment, noise can be reduced by providing the external capacitors 75 and 76 between the first welding terminal 211 and the bypass portion 622 and between the power supply welding terminal 231 and the bypass portion 622. Accordingly, the fourth embodiment obtains the same effects as the second embodiment.

Other Embodiments

In the embodiment described above, the position detecting device is applied to the electronic control throttle device that controls the amount of intake air supplied to the engine installed in the vehicle. However, the field to which the position detecting device is applied is not limited to these examples.

In the embodiments described above, the sensor terminal is formed so that one end portions connected to the lead lines are substantially parallel with the other end portions positioned in the connector portion, as illustrated in FIGS. 2 and 6. However, the shape of the sensor terminal is not limited to these examples.

In the embodiments described above, the bypass portion is formed so as to extend in the y-direction. However, the direction in which the bypass portion extends is not limited to these examples. The bypass portion only needs to be connected to the ground welding terminal on the positive

17

side of the x-axis and extend in a direction different from the direction of the ground welding terminal.

In the second embodiment, the position detecting device has three capacitors. In the fourth embodiment, the position detecting device has two capacitors. The number of capacitors may be one.

In the second and fourth embodiments, capacitors are connected in a direction along the x-axis, which is the short direction of the housing. However, the direction in which capacitors are provided is not limited to these examples.

In the first and second embodiments, in the IC package **10**, the first lead line, the ground lead line, the power supply lead line, and the second lead line are arranged in this order from the positive side to the negative side of the y-axis so as to project in the negative direction of the x-axis. However, the order in which the lead lines are arranged is not limited to these examples. For example, as illustrated in FIG. **9**, the first lead line **16**, the power supply lead line **18**, the ground lead line **17**, and the second lead line **19** may be arranged in this order from the positive side to the negative side of the y-axis so as to project in the negative direction of the x-axis. Also in this case, as illustrated in FIG. **9**, by providing the bypass portion **222** of the ground terminal line **22** in the negative direction of the x-axis with respect to the second lead line **19**, the same effects as in the first and second embodiments can be obtained.

This is also true of the third and fourth embodiments. For example, the same effects as in the third and fourth embodiments can be obtained even when the first lead line **16**, the power supply lead line **18**, the ground lead line **17**, and the dummy lead line **59** are arranged in this order from the positive side to the negative side of the y-axis so as to project in the negative direction of the x-axis, as illustrated in FIG. **10**.

In the first and second embodiments, the IC package has the first signal processing circuit and the second signal processing circuit. In the third and fourth embodiments, the IC package has first signal processing circuit. However, the IC package may have neither the first signal processing circuit nor the second signal processing circuit. In addition, in the IC package, the first magnetic detection element is provided separately from the first signal processing circuit or the second magnetic detection element is provided separately from the second signal processing circuit. The first magnetic detection element may be integrated with the first signal processing circuit or the second magnetic detection element may be integrated with the second signal processing circuit.

The magnetic detection element according to the embodiments described above may be a magnetic detection element such as a hall element or an MR element that only needs to output a signal that depends on a component of a magnetic field or the strength of the component.

In the embodiments described above, the lead lines are electrically connected to the terminal lines by welding. However, the method of electric connection between the lead lines and the terminal lines is not limited to these examples. The welding may be resistance welding or laser welding. In addition, coupling may be performed by soldering or conductive adhesive.

The present disclosure is not limited to these embodiments and may be practiced in various forms without departing from the spirit of the present disclosure.

While the present disclosure has been described with reference to embodiments thereof, it is to be understood that the disclosure is not limited to the embodiments and constructions. The present disclosure is intended to cover vari-

18

ous modification and equivalent arrangements. In addition, the various combinations and configurations, other combinations and configurations, including more, less or only a single element, are also within the spirit and scope of the present disclosure.

The invention claimed is:

1. A position detecting device configured to detect a position of a detection target, the position detecting device comprising:

an IC package including:

a first magnetic detection element configured to output a signal that depends on a first component of an ambient magnetic field or a strength of the first component,

a second magnetic detection element configured to output a signal that depends on a second component of the ambient magnetic field different from the first component or a strength of the second component, a sealing portion in which the first magnetic detection element and the second magnetic detection element are sealed,

a first lead line that projects in a first direction of a first axis from a surface of the sealing portion to output therethrough a first signal output by the first magnetic detection element to an outside,

a ground lead line that projects in the first direction of the first axis from the surface of the sealing portion to cause a current that has flowed through the first magnetic detection element and the second magnetic detection element to flow therethrough to a ground, a power supply lead line that projects in the first direction of the first axis from the surface of the sealing portion to cause a current to flow therethrough toward the first magnetic detection element and the second magnetic detection element, and

a second lead line that projects in the first direction of the first axis from the surface of the sealing portion to output therethrough a second signal output by the second magnetic detection element to the outside, the ground lead line and the power supply lead line provided between the first lead line and the second lead line;

a first terminal line extending in a direction opposite to the first direction from a first connection portion electrically connectable to the first lead line;

a ground terminal line including a ground connection portion, which is electrically connectable to the ground lead line, and a bypass portion, which extends in a second direction of a second axis, the bypass portion being connected to an end of the ground connection portion in the first direction;

a power supply terminal line extending in the direction opposite to the first direction from a power supply connection portion electrically connectable to the power supply lead line;

a second terminal line extending in the direction opposite to the first direction from a second connection portion electrically connectable to the second lead line;

a bypass terminal line positioned on an opposite side of the ground terminal line across the first terminal line or the second terminal line and connected to the bypass portion;

motor terminal lines having one end portions electrically connected to a motor to supply electric power therethrough to the motor to rotate the detection target; and

19

- a connector portion, wherein in the connector portion:
 other end portions of the motor terminal line,
 an end portion of the bypass terminal line opposite to
 a side connected to the bypass portion,
 an end portion of the second terminal line opposite to
 the second connection portion,
 an end portion of the power supply terminal line
 opposite to the power supply connection portion,
 and
 an end portion of the first terminal line opposite to
 the first connection portion are placed in this
 order, and wherein
 the bypass terminal line is connected with the ground
 connection portion via a bypass connection portion
 and the bypass portion, and
 the bypass terminal line, the bypass connection portion,
 and the bypass portion extend to surround an end of
 the power supply connection portion in the first
 direction and an end of the second connection por-
 tion in the first direction.
2. The position detecting device according to claim 1,
 further comprising:
 a capacitor electrically connecting at least one of the first
 terminal line, the power supply terminal line, or the
 second terminal line to the bypass portion.
3. The position detecting device according to claim 2,
 further comprising:
 a housing supporting the first terminal line, the ground
 terminal line, the power supply terminal line, the sec-
 ond terminal line, and the bypass terminal line, wherein
 the capacitor is placed along a short direction of the
 housing in which the housing is shorter in length than
 an other direction perpendicular to the short direction.
4. The position detecting device according to claim 1,
 wherein the first connection portion, the ground connection
 portion, the power supply connection portion, and the sec-
 ond connection portion are positioned at the same flat plane.
5. The position detecting device according to claim 1,
 wherein the bypass portion extends in a direction opposite
 different from the first direction.
6. The position detecting device according to claim 1,
 wherein the first direction of the first axis includes a negative
 direction of the first axis.
7. The position detecting device according to claim 1,
 wherein the first direction of the first axis includes a negative
 direction of an x-axis from the surface of the sealing portion.
8. The position detecting device according to claim 1,
 wherein the direction opposite to the first direction of the
 first axis includes a positive direction of an x-axis from the
 surface of the sealing portion.
9. The position detecting device according to claim 1,
 wherein the end of the power supply connection portion in
 the first direction and the end of the second connection
 portion in the first direction are opposed to the bypass
 portion.
10. The position detecting device according to claim 9,
 wherein the bypass terminal line is connected only with the
 ground connection portion that is a singular element.
11. The position detecting device according to claim 9,
 wherein the bypass terminal line is connected with the
 ground connection portion via a bypass connection portion
 and the bypass portion without branching.
12. A method of manufacturing a position detecting
 device configured to detect a position of a detection target,
 the position detecting device including:
 an IC package including:
 a first magnetic detection element configured to output
 a signal that depends on a first component of an
 ambient magnetic field or a strength of the first
 component,

20

- a second magnetic detection element configured to
 output a signal that depends on a second component
 of the ambient magnetic field different from the first
 component or a strength of the second component,
 a sealing portion in which the first magnetic detection
 element and the second magnetic detection element
 are sealed,
 a first lead line that projects in a first direction of a first
 axis from a surface of the sealing portion to output
 therethrough a first signal output by the first mag-
 netic detection element to an outside,
 a ground lead line that projects in the first direction of
 the first axis from the surface of the sealing portion
 to cause a current that has flowed through the first
 magnetic detection element and the second magnetic
 detection element to flow therethrough to a ground,
 a power supply lead line that projects in the first
 direction of the first axis from the surface of the
 sealing portion to cause a current to flow there-
 through toward the first magnetic detection element
 and the second magnetic detection element, and
 a second lead line that projects in the first direction of
 the first axis from the surface of the sealing portion
 to output therethrough a second signal output by the
 second magnetic detection element to the outside,
 the ground lead line and the power supply lead line
 provided between the first lead line and the second
 lead line;
- a first terminal line extending in a direction opposite to the
 first direction from a first connection portion electri-
 cally connectable to the first lead line;
- a ground terminal line including a ground connection
 portion, which is electrically connectable to the ground
 lead line, and a bypass portion, which extends in a
 second direction of a second axis, the bypass portion
 being connected to an end of the ground connection
 portion in the first direction;
- a power supply terminal line extending in the direction
 opposite to the first direction from a power supply
 connection portion electrically connectable to the
 power supply lead line;
- a second terminal line extending in the direction opposite
 to the first direction from a second connection portion
 electrically connectable to the second lead line,
- a bypass terminal line positioned on an opposite side of
 the ground terminal line across the first terminal line or
 the second terminal line and connected to the bypass
 portion,
- motor terminal lines having one end portions electrically
 connected to a motor to supply electric power there-
 through to the motor to rotate the detection target, and
 a connector portion, wherein in the connector portion:
 other end portions of the motor terminal line,
 an end portion of the bypass terminal line opposite to
 a side connected to the bypass portion,
 an end portion of the second terminal line opposite to
 the second connection portion,
 an end portion of the power supply terminal line
 opposite to the power supply connection portion, and
 an end portion of the first terminal line opposite to the
 first connection portion are placed in this order,
 wherein the method comprising:
 integrally forming, in a terminal original form forming
 process, as an original form of a sensor terminal,
 the first connection portion of the first terminal line,
 the ground connection portion of the ground terminal
 line,

21

the power supply connection portion of the power supply terminal line,
the second connection portion of the second terminal line,
the bypass terminal line, and
a die bar,
such that the die bar is connected to, on a side of the ground connection portion in the first direction,
the first connection portion,
the ground connection portion,
the power supply connection portion,
the second connection portion, and
the bypass terminal line; and
cutting off, in a cutting process after the terminal original form forming process,
the first connection portion from the die bar,
the power supply connection portion from the die bar, and
the second connection portion from the die bar, such that
the bypass terminal line is connected with the ground connection portion via a bypass connection portion and the bypass portion, and
the bypass terminal line, the bypass connection portion, and the bypass portion extend to surround an end of the power supply connection portion in the first direction and an end of the second connection portion in the first direction.

13. A position detecting device configured to detect a position of a detection target, the position detecting device comprising:

an IC package including:

a first magnetic detection element configured to output a signal that depends on a first component of an ambient magnetic field or a strength of the first component,

a second magnetic detection element configured to output a signal that depends on a second component of the ambient magnetic field different from the first component or a strength of the second component,

a sealing portion in which the first magnetic detection element and the second magnetic detection element are sealed,

a first lead line that projects in a first direction of a first axis from a surface of the sealing portion to output therethrough a first signal output by the first magnetic detection element to an outside,

a ground lead line that projects in the first direction of the first axis from the surface of the sealing portion to cause a current that has flowed through the first magnetic detection element and the second magnetic detection element to flow therethrough to a ground,

a power supply lead line that projects in the first direction of the first axis from the surface of the sealing portion to cause a current to flow therethrough toward the first magnetic detection element and the second magnetic detection element, and

a second lead line that projects in the first direction of the first axis from the surface of the sealing portion to output therethrough a second signal output by the second magnetic detection element to the outside, the ground lead line and the power supply lead line provided between the first lead line and the second lead line;

a first terminal line extending in a direction opposite to the first direction from a first connection portion electrically connectable to the first lead line;

22

a ground terminal line including a ground connection portion, which is electrically connectable to the ground lead line, and a bypass portion, which extends in a second direction of a second axis, the bypass portion being connected to an end of the ground connection portion in the first direction;

a power supply terminal line extending in the direction opposite to the first direction from a power supply connection portion electrically connectable to the power supply lead line;

a second terminal line extending in the direction opposite to the first direction from a second connection portion electrically connectable to the second lead line, wherein the bypass portion being connected to a bypass connection portion positioned in the second direction of the second axis with respect to the second connection portion of the second terminal line;

a bypass terminal line positioned on an opposite side of the ground terminal line across the first terminal line or the second terminal line and connected to the bypass portion, the bypass terminal line being connected to the ground terminal line via the bypass connection portion;

motor terminal lines having one end portions electrically connected to a motor to supply electric power therethrough to the motor to rotate the detection target; and

a connector portion, wherein in the connector portion: other end portions of the motor terminal line, an end portion of the bypass terminal line opposite to a side connected to the bypass portion, an end portion of the second terminal line opposite to the second connection portion, an end portion of the power supply terminal line opposite to the power supply connection portion, and an end portion of the first terminal line opposite to the first connection portion are placed in this order, and the end portion of the bypass terminal line is arranged adjacently to motor connector terminals of the motor terminal lines.

14. A method of manufacturing a position detecting device configured to detect a position of a detection target, the position detecting device including:

an IC package including:

a first magnetic detection element configured to output a signal that depends on a first component of an ambient magnetic field or a strength of the first component,

a second magnetic detection element configured to output a signal that depends on a second component of the ambient magnetic field different from the first component or a strength of the second component,

a sealing portion in which the first magnetic detection element and the second magnetic detection element are sealed,

a first lead line that projects in a first direction of a first axis from a surface of the sealing portion to output therethrough a first signal output by the first magnetic detection element to an outside,

a ground lead line that projects in the first direction of the first axis from the surface of the sealing portion to cause a current that has flowed through the first magnetic detection element and the second magnetic detection element to flow therethrough to a ground,

a power supply lead line that projects in the first direction of the first axis from the surface of the sealing portion to cause a current to flow therethrough toward the first magnetic detection element and the second magnetic detection element, and

23

a second lead line that projects in the first direction of the first axis from the surface of the sealing portion to output therethrough a second signal output by the second magnetic detection element to the outside, the ground lead line and the power supply lead line provided between the first lead line and the second lead line;

a first terminal line extending in a direction opposite to the first direction from a first connection portion electrically connectable to the first lead line;

a ground terminal line including a ground connection portion, which is electrically connectable to the ground lead line, and a bypass portion, which extends in a second direction of a second axis, the bypass portion being connected to an end of the ground connection portion in the first direction;

a power supply terminal line extending in the direction opposite to the first direction from a power supply connection portion electrically connectable to the power supply lead line;

a second terminal line extending in the direction opposite to the first direction from a second connection portion electrically connectable to the second lead line, wherein the bypass portion being connected to a bypass connection portion positioned in the second direction of the second axis with respect to the second connection portion of the second terminal line,

a bypass terminal line positioned on an opposite side of the ground terminal line across the first terminal line or the second terminal line and connected to the bypass portion, the bypass terminal line being connected to the ground terminal line via the bypass connection portion,

motor terminal lines having one end portions electrically connected to a motor to supply electric power there-through to the motor to rotate the detection target, and a connector portion, wherein in the connector portion: other end portions of the motor terminal line,

24

an end portion of the bypass terminal line opposite to a side connected to the bypass portion,

an end portion of the second terminal line opposite to the second connection portion,

an end portion of the power supply terminal line opposite to the power supply connection portion, and

an end portion of the first terminal line opposite to the first connection portion are placed in this order, and the end portion of the bypass terminal line is arranged adjacently to motor connector terminals of the motor terminal lines,

wherein the method comprising:

integrally forming, in a terminal original form forming process, as an original form of a sensor terminal,

the first connection portion of the first terminal line,

the ground connection portion of the ground terminal line,

the power supply connection portion of the power supply terminal line,

the second connection portion of the second terminal line,

the bypass terminal line, and

a die bar,

such that the die bar is connected to, on a side of the ground connection portion in the first direction,

the first connection portion,

the ground connection portion,

the power supply connection portion,

the second connection portion, and

the bypass terminal line; and

cutting off, in a cutting process after the terminal original form forming process,

the first connection portion from the die bar,

the power supply connection portion from the die bar, and

the second connection portion from the die bar.

* * * * *