

US011162531B2

(12) **United States Patent**  
**McNamara et al.**

(10) **Patent No.:** **US 11,162,531 B2**  
(45) **Date of Patent:** **Nov. 2, 2021**

(54) **SOLENOID LOW FRICTION BEARING LINER**

(56) **References Cited**

(71) Applicant: **SAINT-GOBAIN PERFORMANCE PLASTICS CORPORATION**, Solon, OH (US)

U.S. PATENT DOCUMENTS

2,559,750 A 7/1951 Berry  
2,559,752 A 7/1951 Berry  
(Continued)

(72) Inventors: **Brian McNamara**, Sixmilebridge (IE);  
**Ian D. Hutcheson**, Dublin (IE);  
**Gerard T. Buss**, Bedford, NH (US);  
**David A. Rich**, Nashua, NH (US)

FOREIGN PATENT DOCUMENTS

JP 2014186303 A 10/2014  
JP 2015132722 A 7/2015  
(Continued)

(73) Assignee: **SAINT-GOBAIN PERFORMANCE PLASTICS CORPORATION**, Solon, OH (US)

OTHER PUBLICATIONS

(\*) Notice: Subject to any disclaimer, the term of this patent is extended or adjusted under 35 U.S.C. 154(b) by 167 days.

International Search Report and Written Opinion for PCT/US2019/067018, dated Apr. 20, 2020, 13 pages.  
(Continued)

(21) Appl. No.: **16/718,278**

*Primary Examiner* — Shawki S Ismail

(22) Filed: **Dec. 18, 2019**

*Assistant Examiner* — Lisa N Homza

(65) **Prior Publication Data**

US 2020/0208681 A1 Jul. 2, 2020

(74) *Attorney, Agent, or Firm* — Abel Schillinger, LLP; Chi Suk Kim

**Related U.S. Application Data**

(57) **ABSTRACT**

(60) Provisional application No. 62/785,488, filed on Dec. 27, 2018.

The present disclosure relates to a low friction bearing liner for a solenoid that may include a core layer, a first outer layer overlying a first surface of the core layer, a second outer layer overlying the first outer layer, a first inner layer overlying a second surface of the core layer that is opposite of the first surface of the core layer, and a second inner layer overlying the first inner layer. The first outer layer and the first inner layer may include a fluoropolymer material and may have a melt flow rate of at least about 2 g/10 min at 372° C. The second outer layer and the second inner layer may include a fluoropolymer material distinct from the fluoropolymer material of the first outer layer and may have a surface coefficient of friction of not greater than about 0.2.

(51) **Int. Cl.**  
*H01F 3/00* (2006.01)  
*F16C 33/12* (2006.01)  
(Continued)

(52) **U.S. Cl.**  
CPC ..... *F16C 33/122* (2013.01); *H01F 7/081* (2013.01); *H01F 7/16* (2013.01); *F16C 2380/00* (2013.01); *H01F 2007/086* (2013.01)

(58) **Field of Classification Search**  
CPC ..... *F16C 33/122*; *F16C 2380/00*; *F16C 2208/30*; *F16C 2202/02*; *F16C 33/121*;  
(Continued)

**9 Claims, 3 Drawing Sheets**

**100**

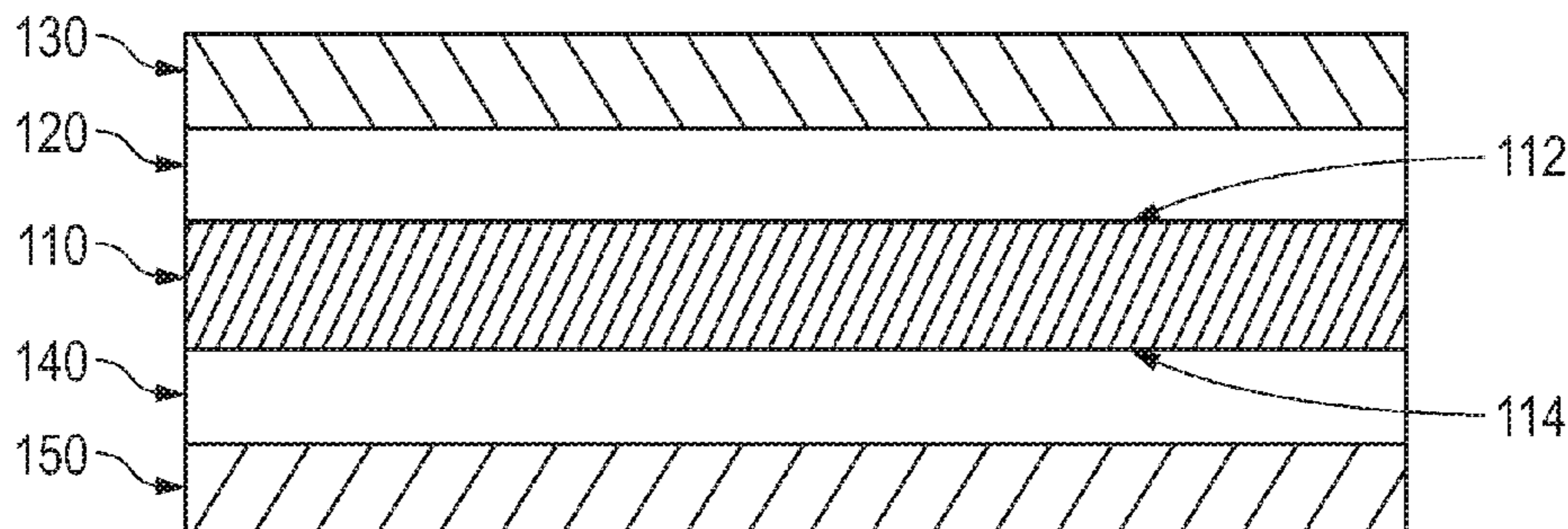

|      |  |   |
|------|--|---|
| (51) | <b>Int. Cl.</b><br><i>H01F 7/08</i> (2006.01)<br><i>H01F 7/16</i> (2006.01)  | 7,235,302 B2 6/2007 Jing et al.<br>7,942,581 B2* 5/2011 Leonardelli ..... F16C 33/201<br>384/276  |
| (58) | <b>Field of Classification Search</b><br>CPC ..... F16C 33/125; H01F 7/081; H01F 7/16;<br>H01F 2007/163; H01F 2007/086<br>USPC ..... 335/279<br>See application file for complete search history.  | 8,530,746 B2* 9/2013 Zheng ..... B32B 27/08<br>174/120 R<br>9,014,611 B2 4/2015 Ishii et al.<br>2005/0141797 A1 6/2005 Kinno et al.<br>2011/0236691 A1 9/2011 Fukumoto et al.<br>2012/0315418 A1 12/2012 Nakajima et al.<br>2014/0170409 A1 6/2014 Blackman et al.<br>2015/0307670 A1* 10/2015 McNamara ..... C08J 5/04<br>428/141<br>2016/0062280 A1 3/2016 Kinuta<br>2020/0207125 A1* 7/2020 McNamara ..... B41J 11/057 |
| (56) | <b>References Cited</b><br><br>U.S. PATENT DOCUMENTS<br><br>2,833,686 A 5/1958 Sandt<br>2,946,763 A 7/1960 Manville et al.<br>3,179,614 A 4/1965 Edwards<br>3,179,634 A 4/1965 Edwards<br>3,616,177 A 10/1971 Gumerman<br>4,518,938 A* 5/1985 Bartholomaus ..... H01F 7/1607<br>335/255<br><br>4,628,003 A 12/1986 Katz<br>5,106,673 A 4/1992 Effenberger et al.<br>5,238,748 A 8/1993 Effenberger et al.<br>5,731,088 A 3/1998 La Court<br>6,726,994 B1* 4/2004 Araki ..... B32B 27/20<br>428/411.1 | FOREIGN PATENT DOCUMENTS<br><br>KR 20080012242 A 2/2008<br>WO 2012050929 A2 4/2012<br><br>OTHER PUBLICATIONS<br><br>International Search Report and Written Opinion for PCT/US2019/<br>067023, dated Apr. 21, 2020, 9 pages.<br><br>* cited by examiner   |

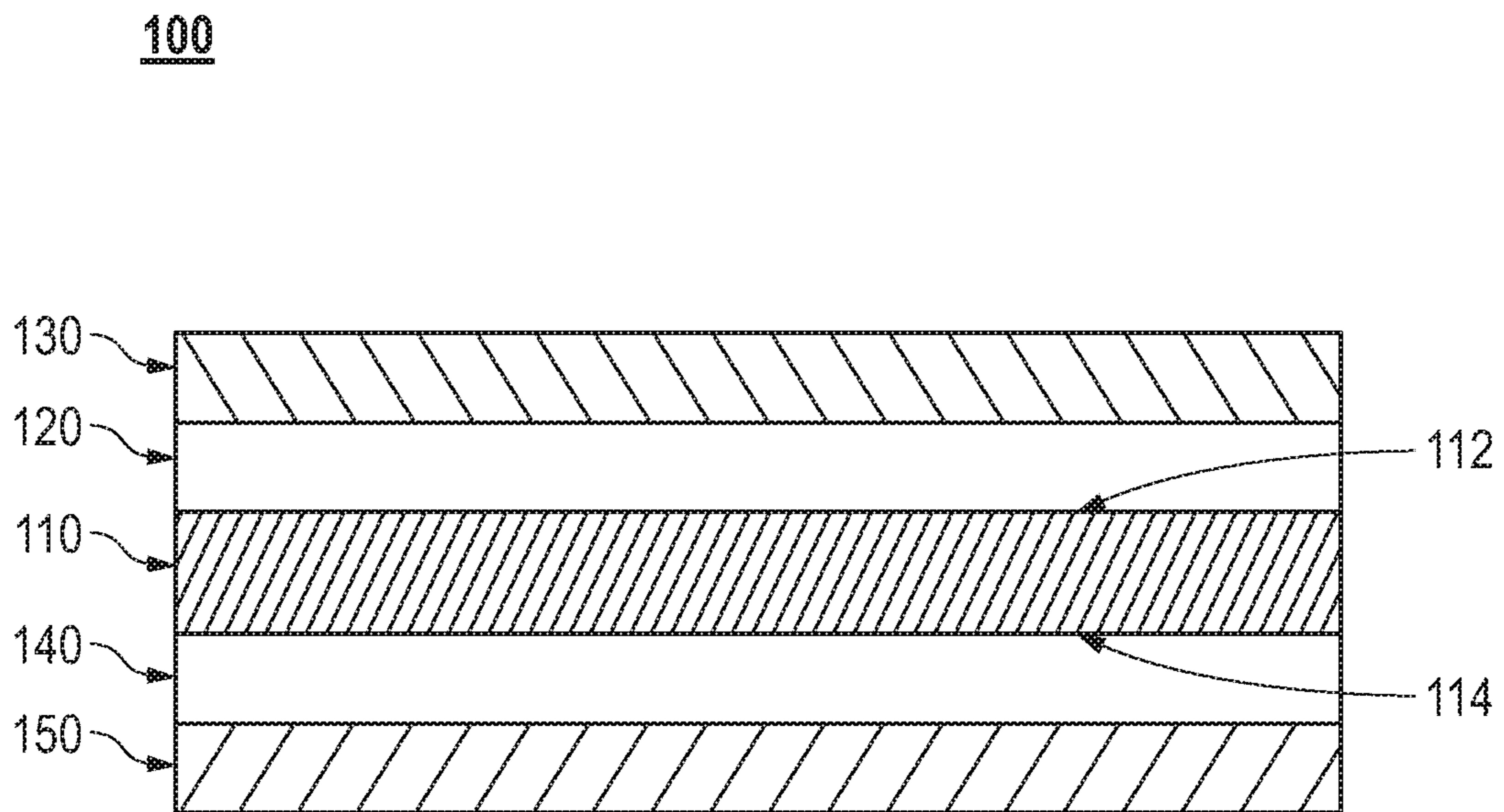

*FIG. 1*





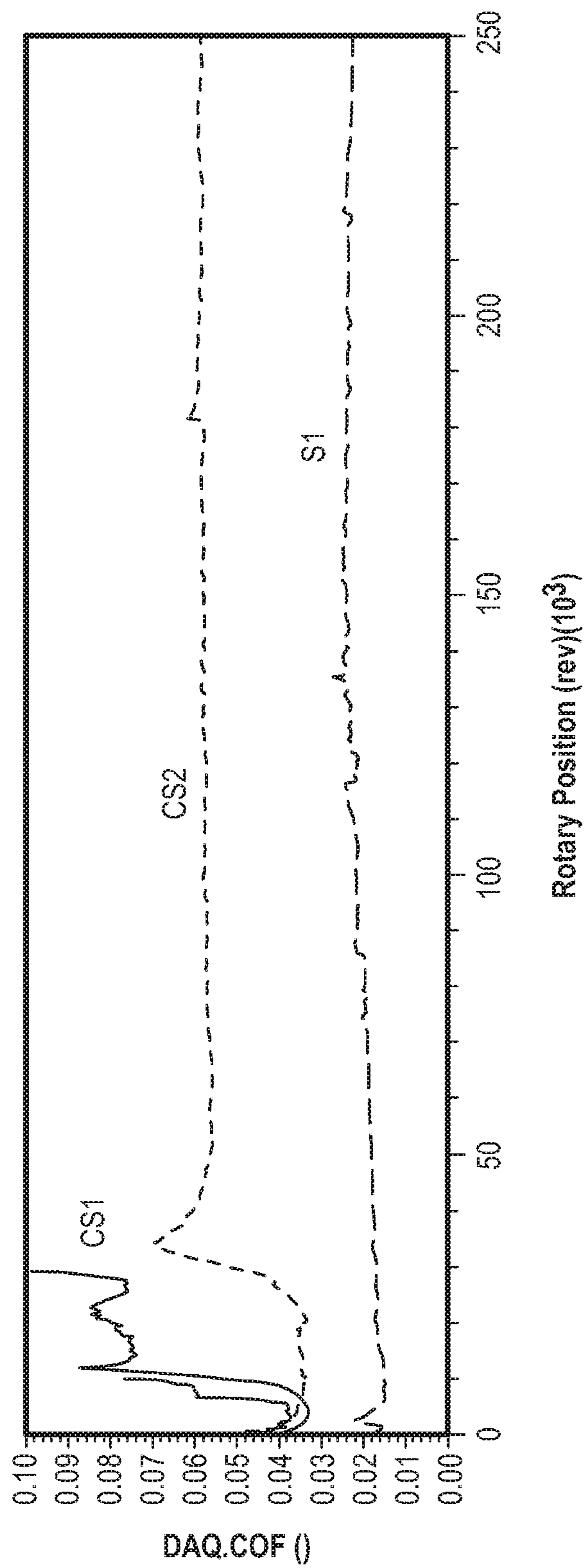

FIG. 3

1

## SOLENOID LOW FRICTION BEARING LINER

### CROSS-REFERENCE TO RELATED APPLICATION(S)

This application claims priority under 35 U.S.C. § 119(e) to U.S. Provisional Patent Application No. 62/785,488, entitled "SOLENOID LOW FRICTION BEARING LINER," by Brian MCNAMARA et al., filed Dec. 27, 2018, which is assigned to the current assignee hereof and is incorporated herein by reference in its entirety.

### FIELD OF THE DISCLOSURE

The present disclosure relates to a low friction bearing liner and, in particular, a low friction bearing liner for a use in a solenoid. The present disclosure further relates to a solenoid that includes the low friction bearing liner.

### BACKGROUND

Electromagnetic solenoids generally include a barrel and a moving armature or piston within the barrel. Since the moving armature or piston contact the inner surface of the barrel during use, friction between the two parts can cause extreme metal fatigue and wear, which can reduce life expectancy of the solenoid. Accordingly, additional components within the solenoid, i.e., liners, which can reduce friction between the moving armature or piston and the inner surface of the barrel during use are desired.

### SUMMARY

According to a first aspect, a low friction bearing liner for a solenoid may include a core layer, a first outer layer overlying a first surface of the core layer, a second outer layer overlying the first outer layer, a first inner layer overlying a second surface of the core layer that is opposite of the first surface of the core layer, and a second inner layer overlying the first inner layer. The first outer layer may include a fluoropolymer material and may have a melt flow rate of at least about 2 g/10 min at 372° C. The second outer layer may include a fluoropolymer material distinct from the fluoropolymer material of the first outer layer and may have a surface coefficient of friction of not greater than about 0.2. The first inner layer may include a fluoropolymer material and may have a melt flow rate of at least about 2 g/10 min at 372° C. The second inner layer may include a fluoropolymer material distinct from the fluoropolymer material of the first outer layer and may have a surface coefficient of friction of not greater than about 0.2.

According to a first aspect, a low friction bearing liner for a solenoid may include a core layer, a first outer layer overlying a first surface of the core layer, a second outer layer overlying the first outer layer, a first inner layer overlying a second surface of the core layer that is opposite of the first surface of the core layer, and a second inner layer overlying the first inner layer. The first outer layer may include at least one of a fluorinated ethylene propylene material, a perfluoroalkoxy alkane material, a modified PTFE material, or a combination thereof. The second outer layer may include a polytetrafluoroethylene material or a mixture of a polytetrafluoroethylene material and a fluorinated ethylene propylene material, a perfluoroalkoxy alkane material, a modified PTFE material. The first inner layer may include a fluorinated ethylene propylene material, a

2

perfluoroalkoxy alkane material, a modified PTFE material, or a combination thereof. The second inner layer may include a polytetrafluoroethylene material or a mixture of a polytetrafluoroethylene material and a fluorinated ethylene propylene material, a perfluoroalkoxy alkane material, a modified PTFE material.

According to yet another aspect, a solenoid may include a barrel, an armature within the barrel, and a low friction bearing liner disposed between an inner surface of the barrel and an outer surface of the armature. The low friction bearing liner for a solenoid may include a core layer, a first outer layer overlying a first surface of the core layer, a second outer layer overlying the first outer layer, a first inner layer overlying a second surface of the core layer that is opposite of the first surface of the core layer, and a second inner layer overlying the first inner layer. The first outer layer may include a fluoropolymer material and may have a melt flow rate of at least about 2 g/10 min at 372° C. The second outer layer may include a fluoropolymer material distinct from the fluoropolymer material of the first outer layer and may have a surface coefficient of friction of not greater than about 0.2. The first inner layer may include a fluoropolymer material and may have a melt flow rate of at least about 2 g/10 min at 372° C. The second inner layer may include a fluoropolymer material distinct from the fluoropolymer material of the first outer layer and may have a surface coefficient of friction of not greater than about 0.2.

According to yet another aspect, a solenoid may include a barrel, an armature within the barrel, and a low friction bearing liner disposed between an inner surface of the barrel and an outer surface of the armature. The low friction bearing liner for a solenoid may include a core layer, a first outer layer overlying a first surface of the core layer, a second outer layer overlying the first outer layer, a first inner layer overlying a second surface of the core layer that is opposite of the first surface of the core layer, and a second inner layer overlying the first inner layer. The first outer layer may include at least one of a fluorinated ethylene propylene material, a perfluoroalkoxy alkane material, a modified PTFE material, or a combination thereof. The second outer layer may include a polytetrafluoroethylene material or a mixture of a polytetrafluoroethylene material and a fluorinated ethylene propylene material, a perfluoroalkoxy alkane material, a modified PTFE material. The first inner layer may include a fluorinated ethylene propylene material, a perfluoroalkoxy alkane material, a modified PTFE material, or a combination thereof. The second inner layer may include a polytetrafluoroethylene material or a mixture of a polytetrafluoroethylene material and a fluorinated ethylene propylene material, a perfluoroalkoxy alkane material, a modified PTFE material.

### BRIEF DESCRIPTION OF THE DRAWINGS

Embodiments are illustrated by way of example and are not limited to the accompanying figures.

FIG. 1 includes an illustration of a low friction bearing liner configuration according to embodiments described herein,

FIG. 2 includes an illustration of a solenoid that includes a low friction bearing liner according to embodiments described herein, and

FIG. 3 includes a plot of the wear rotations vs. the coefficient of friction for sample low friction bearing liners.



Skilled artisans appreciate that elements in the figures are illustrated for simplicity and clarity and have not necessarily been drawn to scale.

#### DETAILED DESCRIPTION

The following discussion will focus on specific implementations and embodiments of the teachings. The detailed description is provided to assist in describing certain embodiments and should not be interpreted as a limitation on the scope or applicability of the disclosure or teachings. It will be appreciated that other embodiments can be used based on the disclosure and teachings as provided herein.

The terms “comprises,” “comprising,” “includes,” “including,” “has,” “having” or any other variation thereof, are intended to cover a non-exclusive inclusion. For example, a method, article, or apparatus that comprises a list of features is not necessarily limited only to those features but may include other features not expressly listed or inherent to such method, article, or apparatus. Further, unless expressly stated to the contrary, “or” refers to an inclusive-or and not to an exclusive-or. For example, a condition A or B is satisfied by any one of the following: A is true (or present) and B is false (or not present), A is false (or not present) and B is true (or present), and both A and B are true (or present).

Also, the use of “a” or “an” is employed to describe elements and components described herein. This is done merely for convenience and to give a general sense of the scope of the invention. This description should be read to include one, at least one, or the singular as also including the plural, or vice versa, unless it is clear that it is meant otherwise. For example, when a single item is described herein, more than one item may be used in place of a single item. Similarly, where more than one item is described herein, a single item may be substituted for that more than one item.

Embodiments described herein are generally directed to a low friction bearing liner for a solenoid. According to certain embodiments, the low friction bearing liner may include a five component multilayer structure that includes a core layer, a first outer layer overlying a first surface of the core layer, a second outer layer overlying the first outer layer, a first inner layer overlying a second surface of the core layer that is opposite of the first surface of the core layer, and a second inner layer overlying the first inner layer.

For purposes of illustration, FIG. 1 includes an illustration of a low friction bearing liner **100** according to embodiments described herein. As shown in FIG. 1, a low friction bearing liner **100** may include a core layer **110**, a first outer layer **120** overlying a first surface **112** of the core layer **110**, a second outer layer **130** overlying the first outer layer **120**, a first inner layer **140** overlying a second surface **114** of the core layer **110** that is opposite of the first surface **112** of the core layer **110**, and a second inner layer **150** overlying the first inner layer **140**.

According to a certain embodiments, the core layer **110** may include a polyimide material. According to certain embodiments, the core layer **110** may include a particular content of polyimide material. For example, the core layer **110** may include a content of polyimide material of at least about 50 wt. % for a total weight of the core layer **110**, such as, at least about 55 wt. % or at least about 60 wt. % or at least about 65 wt. % or at least about 70 wt. % or at least about 75 wt. % or at least about 80 wt. % or at least about 85 wt. % or at least about 90 wt. % or at least about 95 wt. % or at least about 96 wt. % or at least about 97 wt. % or at least about 98

wt. % or at least about 99 wt. %. According to still other embodiments, the core layer **110** may include a content of polyimide material of not greater than about 100 wt. % for a total weight of the core layer **110**. It will be appreciated that the content of polyimide in the core layer **110** may be within a range between any of the minimum and maximum values noted above. It will be further appreciated that the content of polyimide in the core layer **110** may be any value between any of the minimum and maximum values noted above.

According to still other embodiments, the core layer **110** may consist of a polyimide material.

According to yet other embodiments, the first outer layer **120** may include a fluoropolymer material. According to certain embodiments, the first outer layer **120** may include a particular content of fluoropolymer material. For example, the first outer layer **120** may include a content of fluoropolymer material of at least about 50 wt. % for a total weight of the first outer layer **120**, such as, at least about 55 wt. % or at least about 60 wt. % or at least about 65 wt. % or at least about 70 wt. % or at least about 75 wt. % or at least about 80 wt. % or at least about 85 wt. % or at least about 90 wt. % or at least about 95 wt. % or at least about 96 wt. % or at least about 97 wt. % or at least about 98 wt. % or at least about 99 wt. %. According to still other embodiments, the first outer layer **120** may include a content of fluoropolymer material not greater than about 100 wt. % for a total weight of the first outer layer **120**. It will be appreciated that the content of fluoropolymer material in the first outer layer **120** may be within a range between any of the minimum and maximum values noted above. It will be further appreciated that the content of fluoropolymer material in the first outer layer **120** may be any value between any of the minimum and maximum values noted above.

According to still other embodiments, the first outer layer **120** may consist of a fluoropolymer material.

According to still other embodiments, the first outer layer **120** may have a particular melt flow rate. It will be appreciated that for purposes of embodiments described herein, the melt flow rate of a particular material or layer may be measured according to ASTM #D-2116 at a temperature of 372° C. According to certain embodiments, the first outer layer **120** may have a melt flow rate of at least about 2.0 g/10 min.

According to yet other embodiments, the first outer layer **120** may include at least one of a fluorinated ethylene propylene material, a perfluoroalkoxy alkane material, a modified PTFE material, or a combination thereof. According to still other embodiments, the first outer layer **120** may consist of at least about of a fluorinated ethylene propylene material, a perfluoroalkoxy alkane material, a modified PTFE material, or a combination thereof.

According to yet other embodiments, the first outer layer **120** may include a fluorinated ethylene propylene material. According to certain embodiments, the first outer layer **120** may include a particular content of fluorinated ethylene propylene material. For example, the first outer layer **120** may include a content of fluorinated ethylene propylene material of at least about 30 wt. % for a total weight of the first outer layer **120**, such as, at least about 35 wt. % or at least about 40 wt. % or at least about 45 wt. % or at least about 50 wt. % or at least about 55 wt. % or at least about 60 wt. % or at least about 65 wt. % or at least about 70 wt. % or at least about 75 wt. % or at least about 80 wt. % or at least about 85 wt. % or at least about 90 wt. % or at least about 95 wt. % or at least about 96 wt. % or at least about 97 wt. % or at least about 98 wt. % or at least about 99 wt. %.



5

According to still other embodiments, the first outer layer **120** may include a content of fluorinated ethylene propylene material not greater than about 100 wt. % for a total weight of the first outer layer **120**. It will be appreciated that the content of fluorinated ethylene propylene material in the first outer layer **120** may be within a range between any of the minimum and maximum values noted above. It will be further appreciated that the content of fluorinated ethylene propylene material in the first outer layer **120** may be any value between any of the minimum and maximum values noted above.

According to still other embodiments, the first outer layer **120** may consist of a fluorinated ethylene propylene material.

According to yet other embodiments, the first outer layer **120** may include a perfluoroalkoxy alkane material. According to certain embodiments, the first outer layer **120** may include a particular content of perfluoroalkoxy alkane material. For example, the first outer layer **120** may include a content of perfluoroalkoxy alkane material of at least about 30 wt. % for a total weight of the first outer layer **120**, such as, at least about 35 wt. % or at least about 40 wt. % or at least about 45 wt. % or at least about 50 wt. % or at least about 55 wt. % or at least about 60 wt. % or a least about 65 wt. % or a least about 70 wt. % or a least about 75 wt. % or a least about 80 wt. % or a least about 85 wt. % or a least about 90 wt. % or a least about 95 wt. % or at least about 96 wt. % or a least about 97 wt. % or a least about 98 wt. % or a least about 99 wt. %. According to still other embodiments, the first outer layer **120** may include a content of perfluoroalkoxy alkane material not greater than about 100 wt. % for a total weight of the first outer layer **120**. It will be appreciated that the content of perfluoroalkoxy alkane material in the first outer layer **120** may be within a range between any of the minimum and maximum values noted above. It will be further appreciated that the content of perfluoroalkoxy alkane material in the first outer layer **120** may be any value between any of the minimum and maximum values noted above.

According to still other embodiments, the first outer layer **120** may consist of a perfluoroalkoxy alkane material.

According to yet other embodiments, the first outer layer **120** may include a modified PTFE material. According to certain embodiments, the first outer layer **120** may include a particular content of modified PTFE material. For example, the first outer layer **120** may include a content of modified PTFE material of at least about 30 wt. % for a total weight of the first outer layer **120**, such as, at least about 35 wt. % or at least about 40 wt. % or at least about 45 wt. % or at least about 50 wt. % or at least about 55 wt. % or at least about 60 wt. % or a least about 65 wt. % or a least about 70 wt. % or a least about 75 wt. % or a least about 80 wt. % or a least about 85 wt. % or a least about 90 wt. % or a least about 95 wt. % or at least about 96 wt. % or a least about 97 wt. % or a least about 98 wt. % or a least about 99 wt. %. According to still other embodiments, the first outer layer **120** may include a content of modified PTFE material not greater than about 100 wt. % for a total weight of the first outer layer **120**. It will be appreciated that the content of modified PTFE material in the first outer layer **120** may be within a range between any of the minimum and maximum values noted above. It will be further appreciated that the content of modified PTFE material in the first outer layer **120** may be any value between any of the minimum and maximum values noted above.

According to still other embodiments, the first outer layer **120** may consist of a modified PTFE material.

6

According to still other embodiments, the first outer layer **120** may contact the first surface **112** of the core layer **110**. According to still other embodiments, the first outer layer **120** may be bonded to the first surface **112** of the core layer **110**. According to yet other embodiments, the first outer layer **120** may be laminated to the first surface **112** of the core layer **110**.

According to other embodiments, the second outer layer **130** may include a fluoropolymer material that is distinct from the fluoropolymer material of the first outer layer **120**. According to certain embodiments, the second outer layer **130** may include a particular content of fluoropolymer material. For example, the second outer layer **130** may include a content of fluoropolymer material of at least about 50 wt. % for a total weight of the second outer layer **130**, such as, at least about 55 wt. % or at least about 60 wt. % or a least about 65 wt. % or a least about 70 wt. % or a least about 75 wt. % or a least about 80 wt. % or a least about 85 wt. % or a least about 90 wt. % or a least about 95 wt. % or at least about 96 wt. % or a least about 97 wt. % or a least about 98 wt. % or a least about 99 wt. %. According to still other embodiments, the second outer layer **130** may include a content of fluoropolymer material not greater than about 100 wt. % for a total weight of the second outer layer **130**. It will be appreciated that the content of fluoropolymer material in the second outer layer **130** may be within a range between any of the minimum and maximum values noted above. It will be further appreciated that the content of fluoropolymer material in the second outer layer **130** may be any value between any of the minimum and maximum values noted above.

According to still other embodiments, the second outer layer **130** may consist of a fluoropolymer material that is distinct from the fluoropolymer material of the first outer layer **120**.

According to yet other embodiments, the second outer layer **130** may have a particular surface coefficient of friction. It will be appreciated that for purposes of embodiments described herein, the surface coefficient of friction of a particular layer may be measured under a 9 newton normal force at 260 mm/sec in contact with a quarter inch polyimide wear sphere at a temperature of 140° C. and lubricated with 6,000 cs silicone oil. According to certain embodiments, the second outer layer **130** may have a surface coefficient of friction of not greater than about 0.2, such as, not greater than about 0.15 or not greater than about 0.1 or not greater than about 0.05 or not greater than about 0.04 or not greater than about 0.035 or not greater than about 0.034 or not greater than about 0.033 or not greater than about 0.032 or not greater than about 0.031 or not greater than about 0.031 or not greater than about 0.030 or not greater than about 0.029 or not greater than about 0.028 or not greater than about 0.027 or not greater than about 0.026 or not greater than about 0.025 or not greater than about 0.024 or not greater than about 0.023 or not greater than about 0.022 or not greater than about 0.021 or not greater than about 0.020 or not greater than about 0.019 or not greater than about 0.018 or not greater than about 0.017 or not greater than about 0.016 or even not greater than about 0.015. According to still other embodiments, the second outer layer **130** may have a surface coefficient of friction of at least about 0.010, such as, at least about 0.011 or even at least about 0.012. It will be appreciated that the surface coefficient of friction of the second outer layer **130** may be within a range between any of the minimum and maximum values noted above. It will be further appreciated that the surface coefficient of



friction of the second outer layer **130** may be any value between any of the minimum and maximum values noted above.

According to other embodiments, the second outer layer **130** may include at least one of a polytetrafluoroethylene material or a mixture of a polytetrafluoroethylene material and a fluorinated ethylene propylene material, a perfluoroalkoxy alkane material, or a modified PTFE material. According to still other embodiments, the second outer layer **130** may consist of at least one of a polytetrafluoroethylene material or a mixture of a polytetrafluoroethylene material and a fluorinated ethylene propylene material, a perfluoroalkoxy alkane material, or a modified PTFE material.

According to yet other embodiments, the second outer layer **130** may include a polytetrafluoroethylene material. According to certain embodiments, the second outer layer **130** may include a particular content of polytetrafluoroethylene material. For example, the second outer layer **130** may include a content of polytetrafluoroethylene material of at least about 50 wt. % for a total weight of the second outer layer **130**, such as, at least about 55 wt. % or at least about 60 wt. % or at least about 65 wt. % or at least about 70 wt. % or at least about 75 wt. % or at least about 80 wt. % or at least about 85 wt. % or at least about 90 wt. % or at least about 95 wt. % or at least about 96 wt. % or at least about 97 wt. % or at least about 98 wt. % or at least about 99 wt. %. According to still other embodiments, the second outer layer **130** may include a content of not greater than about 100 wt. % for a total weight of the second outer layer **130**. It will be appreciated that the content of polytetrafluoroethylene material in the second outer layer **130** may be within a range between any of the minimum and maximum values noted above. It will be further appreciated that the content of polytetrafluoroethylene material in the second outer layer **130** may be any value between any of the minimum and maximum values noted above.

According to still other embodiments, the second outer layer **130** may consist of a second outer layer **130**.

According to still other embodiments, the second outer layer **130** may contact the first outer layer **120**. According to still other embodiments, the second outer layer **130** may be bonded to the first outer layer **120**. According to yet other embodiments, the second outer layer **130** may be laminated to the first outer layer **120**.

According to yet other embodiments, the first inner layer **140** may include a fluoropolymer material. According to certain embodiments, the first inner layer **140** may include a particular content of fluoropolymer material. For example, the first inner layer **140** may include a content of fluoropolymer material of at least about 50 wt. % for a total weight of the first inner layer **140**, such as, at least about 55 wt. % or at least about 60 wt. % or at least about 65 wt. % or at least about 70 wt. % or at least about 75 wt. % or at least about 80 wt. % or at least about 85 wt. % or at least about 90 wt. % or at least about 95 wt. % or at least about 96 wt. % or at least about 97 wt. % or at least about 98 wt. % or at least about 99 wt. %. According to still other embodiments, the first inner layer **140** may include a content of fluoropolymer material not greater than about 100 wt. % for a total weight of the first inner layer **140**. It will be appreciated that the content of fluoropolymer material in the first inner layer **140** may be within a range between any of the minimum and maximum values noted above. It will be further appreciated that the content of fluoropolymer material in the first inner layer **140** may be any value between any of the minimum and maximum values noted above.

According to still other embodiments, the first inner layer **140** may consist of a fluoropolymer material.

According to still other embodiments, the first inner layer **140** may have a particular melt flow rate. It will be appreciated that for purposes of embodiments described herein, the melt flow rate of a particular material or layer may be measured according to ASTM #D-2116 at a temperature of 372° C. According to certain embodiments, the first inner layer **140** may have a melt flow rate of at least about 2.0 g/10 min.

According to yet other embodiments, the first inner layer **140** may include at least one of a fluorinated ethylene propylene material, a perfluoroalkoxy alkane material, a modified PTFE material, or a combination thereof. According to still other embodiments, the first inner layer **140** may consist of at least about of a fluorinated ethylene propylene material, a perfluoroalkoxy alkane material, a modified PTFE material, or a combination thereof.

According to yet other embodiments, the first inner layer **140** may include a fluorinated ethylene propylene material. According to certain embodiments, the first inner layer **140** may include a particular content of fluorinated ethylene propylene material. For example, the first inner layer **140** may include a content of fluorinated ethylene propylene material of at least about 30 wt. % for a total weight of the first inner layer **140**, such as, at least about 35 wt. % or at least about 40 wt. % or at least about 45 wt. % or at least about 50 wt. % or at least about 55 wt. % or at least about 60 wt. % or at least about 65 wt. % or at least about 70 wt. % or at least about 75 wt. % or at least about 80 wt. % or at least about 85 wt. % or at least about 90 wt. % or at least about 95 wt. % or at least about 96 wt. % or at least about 97 wt. % or at least about 98 wt. % or at least about 99 wt. %. According to still other embodiments, the first inner layer **140** may include a content of fluorinated ethylene propylene material not greater than about 100 wt. % for a total weight of the first inner layer **140**. It will be appreciated that the content of fluorinated ethylene propylene material in the first inner layer **140** may be within a range between any of the minimum and maximum values noted above. It will be further appreciated that the content of fluorinated ethylene propylene material in the first inner layer **140** may be any value between any of the minimum and maximum values noted above.

According to still other embodiments, the first inner layer **140** may consist of a fluorinated ethylene propylene material.

According to yet other embodiments, the first inner layer **140** may include a perfluoroalkoxy alkane material. According to certain embodiments, the first inner layer **140** may include a particular content of perfluoroalkoxy alkane material. For example, the first inner layer **140** may include a content of perfluoroalkoxy alkane material of at least about 30 wt. % for a total weight of the first inner layer **140**, such as, at least about 35 wt. % or at least about 40 wt. % or at least about 45 wt. % or at least about 50 wt. % or at least about 55 wt. % or at least about 60 wt. % or at least about 65 wt. % or at least about 70 wt. % or at least about 75 wt. % or at least about 80 wt. % or at least about 85 wt. % or at least about 90 wt. % or at least about 95 wt. % or at least about 96 wt. % or at least about 97 wt. % or at least about 98 wt. % or at least about 99 wt. %. According to still other embodiments, the first inner layer **140** may include a content of perfluoroalkoxy alkane material not greater than about 100 wt. % for a total weight of the first inner layer **140**. It will be appreciated that the content of perfluoroalkoxy alkane material in the first inner layer **140** may be within a range



between any of the minimum and maximum values noted above. It will be further appreciated that the content of perfluoroalkoxy alkane material in the first inner layer **140** may be any value between any of the minimum and maximum values noted above.

According to still other embodiments, the first inner layer **140** may consist of a perfluoroalkoxy alkane material.

According to yet other embodiments, the first inner layer **140** may include a modified PTFE material. According to certain embodiments, the first inner layer **140** may include a particular content of modified PTFE material. For example, the first inner layer **140** may include a content of modified PTFE material of at least about 30 wt. % for a total weight of the first inner layer **140**, such as, at least about 35 wt. % or at least about 40 wt. % or at least about 45 wt. % or at least about 50 wt. % or at least about 55 wt. % or at least about 60 wt. % or at least about 65 wt. % or at least about 70 wt. % or at least about 75 wt. % or at least about 80 wt. % or at least about 85 wt. % or at least about 90 wt. % or at least about 95 wt. % or at least about 96 wt. % or at least about 97 wt. % or at least about 98 wt. % or at least about 99 wt. %. According to still other embodiments, the first inner layer **140** may include a content of modified PTFE material not greater than about 100 wt. % for a total weight of the first inner layer **140**. It will be appreciated that the content of modified PTFE material in the first inner layer **140** may be within a range between any of the minimum and maximum values noted above. It will be further appreciated that the content of modified PTFE material in the first inner layer **140** may be any value between any of the minimum and maximum values noted above.

According to still other embodiments, the first inner layer **140** may consist of a modified PTFE material.

According to still other embodiments, the first inner layer **140** may contact the first surface **112** of the core layer **110**. According to still other embodiments, the first inner layer **140** may be bonded to the first surface **112** of the core layer **110**. According to yet other embodiments, the first inner layer **140** may be laminated to the first surface **112** of the core layer **110**.

According to other embodiments, the second inner layer **150** may include a fluoropolymer material that is distinct from the fluoropolymer material of the first inner layer **140**. According to certain embodiments, the second inner layer **150** may include a particular content of fluoropolymer material. For example, the second inner layer **150** may include a content of fluoropolymer material of at least about 50 wt. % for a total weight of the second inner layer **150**, such as, at least about 55 wt. % or at least about 60 wt. % or at least about 65 wt. % or at least about 70 wt. % or at least about 75 wt. % or at least about 80 wt. % or at least about 85 wt. % or at least about 90 wt. % or at least about 95 wt. % or at least about 96 wt. % or at least about 97 wt. % or at least about 98 wt. % or at least about 99 wt. %. According to still other embodiments, the second inner layer **150** may include a content of fluoropolymer material not greater than about 100 wt. % for a total weight of the second inner layer **150**. It will be appreciated that the content of fluoropolymer material in the second inner layer **150** may be within a range between any of the minimum and maximum values noted above. It will be further appreciated that the content of fluoropolymer material in the second inner layer **150** may be any value between any of the minimum and maximum values noted above.

According to still other embodiments, the second inner layer **150** may consist of a fluoropolymer material that is distinct from the fluoropolymer material of the first inner layer **140**.

According to yet other embodiments, the second inner layer **150** may have a particular surface coefficient of friction. It will be appreciated that for purposes of embodiments described herein, the surface coefficient of friction of a particular layer may be measured under a 9 newton normal force at 260 mm/sec in contact with a quarter inch polyimide wear sphere at a temperature of 140° C. and lubricated with 6,000 cs silicone oil. According to certain embodiments, the second inner layer **150** may have a surface coefficient of friction of not greater than about 0.2, such as, not greater than about 0.15 or not greater than about 0.1 or not greater than about 0.05 or not greater than about 0.04 or not greater than about 0.035 or not greater than about 0.034 or not greater than about 0.033 or not greater than about 0.032 or not greater than about 0.031 or not greater than about 0.031 or not greater than about 0.030 or not greater than about 0.029 or not greater than about 0.028 or not greater than about 0.027 or not greater than about 0.026 or not greater than about 0.025 or not greater than about 0.024 or not greater than about 0.023 or not greater than about 0.022 or not greater than about 0.021 or not greater than about 0.020 or not greater than about 0.019 or not greater than about 0.018 or not greater than about 0.017 or not greater than about 0.016 or even not greater than about 0.015. According to still other embodiments, the second inner layer **150** may have a surface coefficient of friction of at least about 0.010, such as, at least about 0.011 or even at least about 0.012. It will be appreciated that the surface coefficient of friction of the second inner layer **150** may be within a range between any of the minimum and maximum values noted above. It will be further appreciated that the surface coefficient of friction of the second inner layer **150** may be any value between any of the minimum and maximum values noted above.

According to other embodiments, the second inner layer **150** may include at least one of a polytetrafluoroethylene material or a mixture of a polytetrafluoroethylene material and a fluorinated ethylene propylene material, a perfluoroalkoxy alkane material, or a modified PTFE material. According to still other embodiments, the second inner layer **150** may consist of at least one of a polytetrafluoroethylene material or a mixture of a polytetrafluoroethylene material and a fluorinated ethylene propylene material, a perfluoroalkoxy alkane material, or a modified PTFE material.

According to yet other embodiments, the second inner layer **150** may include a polytetrafluoroethylene material. According to certain embodiments, the second inner layer **150** may include a particular content of polytetrafluoroethylene material. For example, the second inner layer **150** may include a content of polytetrafluoroethylene material of at least about 50 wt. % for a total weight of the second inner layer **150**, such as, at least about 55 wt. % or at least about 60 wt. % or at least about 65 wt. % or at least about 70 wt. % or at least about 75 wt. % or at least about 80 wt. % or at least about 85 wt. % or at least about 90 wt. % or at least about 95 wt. % or at least about 96 wt. % or at least about 97 wt. % or at least about 98 wt. % or at least about 99 wt. %. According to still other embodiments, the second inner layer **150** may include a content of not greater than about 100 wt. % for a total weight of the second inner layer **150**. It will be appreciated that the content of polytetrafluoroethylene material in the second inner layer **150** may be within a range between any of the minimum and maximum values noted



above. It will be further appreciated that the content of polytetrafluoroethylene material in the second inner layer **150** may be any value between any of the minimum and maximum values noted above.

According to still other embodiments, the second inner layer **150** may consist of a second inner layer **150**.

According to still other embodiments, the second inner layer **150** may contact the first inner layer **140**. According to still other embodiments, the second inner layer **150** may be bonded to the first inner layer **140**. According to yet other

embodiments, the second inner layer **150** may be laminated to the first inner layer **140**. According to yet other embodiments, the low friction bearing liner **100** may have a particular first outer layer thickness ratio  $FOL_T/CL_T$ , where  $FOL_T$  is equal to a thickness of the first outer layer **120** and  $CL_T$  is equal to the thickness of the core layer **110**. For example, the low friction bearing liner **100** may have a first outer layer thickness ratio  $FOL_T/CL_T$  of at least about 0.02, such as, at least about 0.03 or at least about 0.04 or at least about 0.05 or at least about 0.06 or at least about 0.07 or at least about 0.08 or at least about 0.09. According to still other embodiments, the low friction bearing liner **100** may have a first outer layer thickness ratio  $FOL_T/CL_T$  of not greater than about 0.4, such as, not greater than about 0.3 or not greater than about 0.2 or not greater than about 0.19 or not greater than about 0.18 or not greater than about 0.17 or not greater than about 0.16 or not greater than about 0.15 or not greater than about 0.14 or not greater than about 0.13 or not greater than about 0.12 or not greater than about 0.11. It will be appreciated that the first outer layer thickness ratio  $FOL_T/CL_T$  of the low friction bearing liner **100** may be within a range between any of the minimum and maximum values noted above. It will be further appreciated that the first outer layer thickness ratio  $FOL_T/CL_T$  of the low friction bearing liner **100** may be any value between any of the minimum and maximum values noted above.

According to yet other embodiments, the low friction bearing liner **100** may have a particular second outer layer thickness ratio  $SOC_T/CL_T$ , where  $SOC_T$  is equal to a thickness of the second outer layer **130** and  $CL_T$  is equal to the thickness of the core layer **110**. For example, the low friction bearing liner **100** may have a second outer layer thickness ratio  $SOC_T/CL_T$  of at least about 0.02, such as, at least about 0.03 or at least about 0.04 or at least about 0.05 or at least about 0.06 or at least about 0.07 or at least about 0.08 or at least about 0.09. According to still other embodiments, the low friction bearing liner **100** may have a second outer layer thickness ratio  $SOC_T/CL_T$  of not greater than about 0.4, such as, not greater than about 0.3 or not greater than about 0.2 or not greater than about 0.19 or not greater than about 0.18 or not greater than about 0.17 or not greater than about 0.16 or not greater than about 0.15 or not greater than about 0.14 or not greater than about 0.13 or not greater than about 0.12 or not greater than about 0.11. It will be appreciated that the second outer layer thickness ratio  $SOC_T/CL_T$  of the low friction bearing liner **100** may be within a range between any of the minimum and maximum values noted above. It will be further appreciated that the second outer layer thickness ratio  $SOC_T/CL_T$  of the low friction bearing liner **100** may be any value between any of the minimum and maximum values noted above.

According to yet other embodiments, the low friction bearing liner **100** may have a particular first inner layer thickness ratio  $FIL_T/CL_T$ , where  $FIL_T$  is equal to a thickness of the first inner layer **140** and  $CL_T$  is equal to the thickness of the core layer **110**. For example, the low friction bearing

liner **100** may have a first inner layer thickness ratio  $FIL_T/CL_T$  of at least about 0.02, such as, at least about 0.03 or at least about 0.04 or at least about 0.05 or at least about 0.06 or at least about 0.07 or at least about 0.08 or at least about 0.09. According to still other embodiments, the low friction bearing liner **100** may have a first inner layer thickness ratio  $FIL_T/CL_T$  of not greater than about 0.4, such as, not greater than about 0.3 or not greater than about 0.2 or not greater than about 0.19 or not greater than about 0.18 or not greater than about 0.17 or not greater than about 0.16 or not greater than about 0.15 or not greater than about 0.14 or not greater than about 0.13 or not greater than about 0.12 or not greater than about 0.11. It will be appreciated that the first inner layer thickness ratio  $FIL_T/CL_T$  of the low friction bearing liner **100** may be within a range between any of the minimum and maximum values noted above. It will be further appreciated that the first inner layer thickness ratio  $FIL_T/CL_T$  of the low friction bearing liner **100** may be any value between any of the minimum and maximum values noted above.

According to yet other embodiments, the low friction bearing liner **100** may have a particular second inner layer thickness ratio  $SIL_T/CL_T$ , where  $SIL_T$  is equal to a thickness of the second inner layer **150** and  $CL_T$  is equal to the thickness of the core layer **110**. For example, the low friction bearing liner **100** may have a second inner layer thickness ratio  $SIL_T/CL_T$  of at least about 0.02, such as, at least about 0.03 or at least about 0.04 or at least about 0.05 or at least about 0.06 or at least about 0.07 or at least about 0.08 or at least about 0.09. According to still other embodiments, the low friction bearing liner **100** may have a second inner layer thickness ratio  $SIL_T/CL_T$  of not greater than about 0.4, such as, not greater than about 0.3 or not greater than about 0.2 or not greater than about 0.19 or not greater than about 0.18 or not greater than about 0.17 or not greater than about 0.16 or not greater than about 0.15 or not greater than about 0.14 or not greater than about 0.13 or not greater than about 0.12 or not greater than about 0.11. It will be appreciated that the second inner layer thickness ratio  $SIL_T/CL_T$  of the low friction bearing liner **100** may be within a range between any of the minimum and maximum values noted above. It will be further appreciated that the second inner layer thickness ratio  $SIL_T/CL_T$  of the low friction bearing liner **100** may be any value between any of the minimum and maximum values noted above.

According to yet other embodiments, the core layer **110** may have a particular thickness. For example, the core layer **110** may have a thickness of at least about 10  $\mu\text{m}$ , such as, at least about 15  $\mu\text{m}$  or at least about 20  $\mu\text{m}$  or at least about 25  $\mu\text{m}$  or at least about 30  $\mu\text{m}$  or at least about 35  $\mu\text{m}$  or at least about 40  $\mu\text{m}$  or at least about 45  $\mu\text{m}$  or even at least about 49  $\mu\text{m}$ . According to still other embodiments, the core layer **110** may have a thickness of not greater than about 150  $\mu\text{m}$ , such as, not greater than about 145  $\mu\text{m}$  or not greater than about 140  $\mu\text{m}$  or not greater than about 135  $\mu\text{m}$  or not greater than about 130  $\mu\text{m}$  or not greater than about 125  $\mu\text{m}$  or not greater than about 120  $\mu\text{m}$  or not greater than about 115  $\mu\text{m}$  or not greater than about 110  $\mu\text{m}$  or not greater than about 105  $\mu\text{m}$  or not greater than about 100  $\mu\text{m}$  or not greater than about 95  $\mu\text{m}$  or not greater than about 90  $\mu\text{m}$  or not greater than about 85  $\mu\text{m}$  or not greater than about 80  $\mu\text{m}$  or not greater than about 75  $\mu\text{m}$  or not greater than about 70  $\mu\text{m}$  or not greater than about 65  $\mu\text{m}$  or not greater than about 60  $\mu\text{m}$  or not greater than about 55  $\mu\text{m}$  or not greater than about 50  $\mu\text{m}$  or not greater than about 45  $\mu\text{m}$  or not greater than about 40  $\mu\text{m}$  or not greater than about 35  $\mu\text{m}$  or not greater than about 30  $\mu\text{m}$  or not greater than about 25  $\mu\text{m}$  or not



greater than about 20  $\mu\text{m}$  or not greater than about 15  $\mu\text{m}$  or not greater than about 10  $\mu\text{m}$ . It will be appreciated that the thickness of the core layer **110** may be within a range between any of the minimum and maximum values noted above. It will be further appreciated that the thickness of the core layer **110** may be any value between any of the minimum and maximum values noted above.

According to yet other embodiments, the first outer layer **120** may have a particular thickness. For example, the first outer layer **120** may have a thickness of at least about at least about 1  $\mu\text{m}$ , such as, at least about 1.5  $\mu\text{m}$  or at least about 2.0  $\mu\text{m}$  or at least about 2.5  $\mu\text{m}$  or at least about 3.0  $\mu\text{m}$  or at least about 3.5  $\mu\text{m}$  or at least about 4.0  $\mu\text{m}$  or at least about 4.5  $\mu\text{m}$  or even at least about 4.9  $\mu\text{m}$ . According to still other embodiments, the first outer layer **120** may have a thickness of not greater than about 10  $\mu\text{m}$ , such as, not greater than about 9.5  $\mu\text{m}$  or not greater than about 9.0  $\mu\text{m}$  or not greater than about 8.5  $\mu\text{m}$  or not greater than about 8.0  $\mu\text{m}$  or not greater than about 7.5  $\mu\text{m}$  or not greater than about 7.0  $\mu\text{m}$  or not greater than about 6.5  $\mu\text{m}$  or not greater than about 6.0  $\mu\text{m}$  or not greater than about 5.5  $\mu\text{m}$  or not greater than about 5.1  $\mu\text{m}$ . It will be appreciated that the thickness of the first outer layer **120** may be within a range between any of the minimum and maximum values noted above. It will be further appreciated that the thickness of the first outer layer **120** may be any value between any of the minimum and maximum values noted above.

According to yet other embodiments, the second outer layer **130** may have a particular thickness. For example, the second outer layer **130** may have a thickness of at least about at least about 1  $\mu\text{m}$ , such as, at least about 1.5  $\mu\text{m}$  or at least about 2.0  $\mu\text{m}$  or at least about 2.5  $\mu\text{m}$  or at least about 3.0  $\mu\text{m}$  or at least about 3.5  $\mu\text{m}$  or at least about 4.0  $\mu\text{m}$  or at least about 4.5  $\mu\text{m}$  or even at least about 4.9  $\mu\text{m}$ . According to still other embodiments, the second outer layer **130** may have a thickness of not greater than about 10  $\mu\text{m}$ , such as, not greater than about 9.5  $\mu\text{m}$  or not greater than about 9.0  $\mu\text{m}$  or not greater than about 8.5  $\mu\text{m}$  or not greater than about 8.0  $\mu\text{m}$  or not greater than about 7.5  $\mu\text{m}$  or not greater than about 7.0  $\mu\text{m}$  or not greater than about 6.5  $\mu\text{m}$  or not greater than about 6.0  $\mu\text{m}$  or not greater than about 5.5  $\mu\text{m}$  or not greater than about 5.1  $\mu\text{m}$ . It will be appreciated that the thickness of the second outer layer **130** may be within a range between any of the minimum and maximum values noted above. It will be further appreciated that the thickness of the second outer layer **130** may be any value between any of the minimum and maximum values noted above.

According to yet other embodiments, the first inner layer **140** may have a particular thickness. For example, the first inner layer **140** may have a thickness of at least about at least about 1  $\mu\text{m}$ , such as, at least about 1.5  $\mu\text{m}$  or at least about 2.0  $\mu\text{m}$  or at least about 2.5  $\mu\text{m}$  or at least about 3.0  $\mu\text{m}$  or at least about 3.5  $\mu\text{m}$  or at least about 4.0  $\mu\text{m}$  or at least about 4.5  $\mu\text{m}$  or even at least about 4.9  $\mu\text{m}$ . According to still other embodiments, the first inner layer **140** may have a thickness of not greater than about 10  $\mu\text{m}$ , such as, not greater than about 9.5  $\mu\text{m}$  or not greater than about 9.0  $\mu\text{m}$  or not greater than about 8.5  $\mu\text{m}$  or not greater than about 8.0  $\mu\text{m}$  or not greater than about 7.5  $\mu\text{m}$  or not greater than about 7.0  $\mu\text{m}$  or not greater than about 6.5  $\mu\text{m}$  or not greater than about 6.0  $\mu\text{m}$  or not greater than about 5.5  $\mu\text{m}$  or not greater than about 5.1  $\mu\text{m}$ . It will be appreciated that the thickness of the first inner layer **140** may be within a range between any of the minimum and maximum values noted above. It will be further appreciated that the thickness of the first inner layer **140** may be any value between any of the minimum and maximum values noted above.

According to yet other embodiments, the second inner layer **150** may have a particular thickness. For example, the second inner layer **150** may have a thickness of at least about at least about 1  $\mu\text{m}$ , such as, at least about 1.5  $\mu\text{m}$  or at least about 2.0  $\mu\text{m}$  or at least about 2.5  $\mu\text{m}$  or at least about 3.0  $\mu\text{m}$  or at least about 3.5  $\mu\text{m}$  or at least about 4.0  $\mu\text{m}$  or at least about 4.5  $\mu\text{m}$  or even at least about 4.9  $\mu\text{m}$ . According to still other embodiments, the second inner layer **150** may have a thickness of not greater than about 10  $\mu\text{m}$ , such as, not greater than about 9.5  $\mu\text{m}$  or not greater than about 9.0  $\mu\text{m}$  or not greater than about 8.5  $\mu\text{m}$  or not greater than about 8.0  $\mu\text{m}$  or not greater than about 7.5  $\mu\text{m}$  or not greater than about 7.0  $\mu\text{m}$  or not greater than about 6.5  $\mu\text{m}$  or not greater than about 6.0  $\mu\text{m}$  or not greater than about 5.5  $\mu\text{m}$  or not greater than about 5.1  $\mu\text{m}$ . It will be appreciated that the thickness of the second inner layer **150** may be within a range between any of the minimum and maximum values noted above. It will be further appreciated that the thickness of the second inner layer **150** may be any value between any of the minimum and maximum values noted above.

According to still other embodiments, the low friction bearing liner **100** may have a particular thickness. For examples, the low friction bearing liner **100** may have a thickness of at least about 10  $\mu\text{m}$ , such as, at least about 15  $\mu\text{m}$  or at least about 20  $\mu\text{m}$  or at least about 25  $\mu\text{m}$  or at least about 30  $\mu\text{m}$  or at least about 35  $\mu\text{m}$  or at least about 40  $\mu\text{m}$  or at least about 45  $\mu\text{m}$  or at least about 50  $\mu\text{m}$  or at least about 55  $\mu\text{m}$  or at least about 60  $\mu\text{m}$  or at least about 65  $\mu\text{m}$  or even at least about 69  $\mu\text{m}$ . According to still other embodiments, the low friction bearing liner **100** may have a thickness of not greater than about 200  $\mu\text{m}$ , such as, not greater than about 195  $\mu\text{m}$  or not greater than about 190  $\mu\text{m}$  or not greater than about 185  $\mu\text{m}$  or not greater than about 180  $\mu\text{m}$  or not greater than about 175  $\mu\text{m}$  or even not greater than about 170  $\mu\text{m}$  or not greater than about 165  $\mu\text{m}$  or not greater than about 160  $\mu\text{m}$  or not greater than about 155  $\mu\text{m}$  or not greater than about 150  $\mu\text{m}$  or not greater than about 145  $\mu\text{m}$  or not greater than about 140  $\mu\text{m}$  or not greater than about 135  $\mu\text{m}$  or not greater than about 130  $\mu\text{m}$  or not greater than about 125  $\mu\text{m}$  or not greater than about 120  $\mu\text{m}$  or not greater than about 115  $\mu\text{m}$  or not greater than about 110  $\mu\text{m}$  or not greater than about 105  $\mu\text{m}$  or not greater than about 100  $\mu\text{m}$  or not greater than about 95  $\mu\text{m}$  or not greater than about 90  $\mu\text{m}$  or not greater than about 85  $\mu\text{m}$  or not greater than about 80  $\mu\text{m}$  or not greater than about 75  $\mu\text{m}$  or even not greater than about 71  $\mu\text{m}$ . It will be appreciated that the thickness of the low friction bearing liner **100** may be within a range between any of the minimum and maximum values noted above. It will be further appreciated that the thickness of the low friction bearing liner **100** may be any value between any of the minimum and maximum values noted above.

According to still other embodiments, the low friction bearing liner **100** may have a particular wear rating. It will be appreciated that for purposes of embodiments described herein, the wear rating may be tested using a Tribometer Test measured under a 9 newton normal force at 260 mm/sec in contact with a quarter inch polyimide wear sphere at a running temperature of 140° C. and lubricated with 6,000 cs silicone oil. The wear rating is equal to the number of rotations completed before failure in a Tribometer Test and failure is defined as a 50% increase in COF versus steady-state value during the Tribometer test. According to certain embodiments, the low friction bearing liner **100** may have a wear rating of at least about 35,000, such as, at least about 40,000 or at least about 45,000 or at least about 50,000 or at least about 75,000 or at least about 100,000 or at least about



## 15

125,000 or at least about 150,000 or at least about 175,000 or at least about 200,000 or at least about 225,000 or even at least about 250,000.

According to still other embodiments described herein, the low friction bearing liner may be incorporated into a solenoid.

For purposes of illustration, FIG. 2 includes an illustration of a solenoid 200 according to embodiments described herein. As shown in FIG. 2, a solenoid 200 may include a barrel 210, an armature 220 within the barrel 210 and a low friction bearing liner 230 disposed between barrel 210 of the solenoid 200 and the armature 220 of the solenoid 200.

According to certain embodiments, the barrel 210 of the solenoid 200 may also be referred to as a poletube. According to certain embodiments, it may be milled out of a single piece or welded out of at least two pieces.

According to still other embodiments, the armature 220 of the solenoid 200 may also be referred to as a plunger or piston.

According to certain embodiments, the low friction bearing liner 230 may be attached to an inner surface of the barrel 210 of the solenoid.

According to yet other embodiments, the solenoid 200 may be configured such that the armature 220 is a moving part that contacts as surface of the low friction bearing liner 230 during movement.

According to still other embodiments, it will be appreciated that the low friction bearing liner 230 of the solenoid 200, as shown in FIG. 2, may include any of the components and may be described as having any of the characteristics described herein with reference to the low friction bearing liner 100 as shown in FIG. 1. In particular, the low friction bearing liner 230 of the solenoid 200 as shown in FIG. 2, may include, as shown in FIG. 1, a core layer 110, a first outer layer 120 overlying a first surface 112 of the core layer 110, a second outer layer 130 overlying the first outer layer 120, a first inner layer 140 overlying a second surface 114 of the core layer 110 that is opposite of the first surface 112 of the core layer 110, and a second inner layer 150 overlying the first inner layer 140.

Many different aspects and embodiments are possible. Some of those aspects and embodiments are described herein. After reading this specification, skilled artisans will appreciate that those aspects and embodiments are only illustrative and do not limit the scope of the present invention. Embodiments may be in accordance with any one or more of the embodiments as listed below.

## Embodiment 1

A low friction bearing liner for a solenoid, wherein the low friction bearing liner comprises: a core layer comprising a polyimide material; a first outer layer overlying a first surface of the core layer, wherein the first outer layer comprises a fluoropolymer material, and wherein the first outer layer has a melt flow rate of at least about 2 g/10 min at 372° C.; a second outer layer overlying the first outer layer, wherein the second outer layer comprises a fluoropolymer material distinct from the fluoropolymer material of the first outer layer and wherein the first outer layer has a surface coefficient of friction of not greater than about 0.2; a first inner layer overlying a second surface of the core layer, wherein the second surface is opposite of the first surface, wherein the first inner layer comprises a fluoropolymer material, and wherein the first inner layer has a melt flow rate of at least about 2 g/10 min at 372° C.; and a second inner layer overlying the first inner layer, wherein the second

## 16

inner layer comprises a fluoropolymer material distinct from the fluoropolymer material of the first inner layer and wherein the first inner layer has a surface coefficient of friction of not greater than about 0.2.

## Embodiment 2

A low friction bearing liner for a solenoid, wherein the low friction bearing liner comprises: a core layer comprising a polyimide material; a first outer layer overlying a first surface of the core layer, wherein the first outer layer comprises at least one of a fluorinated ethylene propylene material, a perfluoroalkoxy alkane material, a modified PTFE material, or a combination thereof; a second outer layer overlying the first outer layer, wherein the second outer layer comprises at least one of a polytetrafluoroethylene material or a mixture of a polytetrafluoroethylene material and a fluorinated ethylene propylene material, a perfluoroalkoxy alkane material, or a modified PTFE material; a first inner layer overlying a second surface of the core layer, wherein the second surface is opposite of the first surface, wherein the first inner layer comprises at least one of a fluorinated ethylene propylene material, a perfluoroalkoxy alkane material, a modified PTFE material, or a combination thereof; and a second inner layer overlying the first inner layer, wherein the second inner layer comprises at least one of a polytetrafluoroethylene material or a mixture of a polytetrafluoroethylene material and a fluorinated ethylene propylene material, a perfluoroalkoxy alkane material, or a modified PTFE material.

## Embodiment 3

The low friction bearing liner of embodiment 2, wherein the first outer layer has a melt flow rate of at least about 2 g/10 min at 372° C.

## Embodiment 4

The low friction bearing liner of embodiment 2, wherein the first outer layer has a surface coefficient of friction of not greater than about 0.2.

## Embodiment 5

The low friction bearing liner of embodiment 2, wherein the first inner layer has a melt flow rate of at least about 2 g/10 min at 372° C.

## Embodiment 6

The low friction bearing liner of embodiment 2, wherein the first inner layer has a surface coefficient of friction of not greater than about 0.2.

## Embodiment 7

The low friction bearing liner of embodiment 1, wherein the first outer layer comprises at least one of a fluorinated ethylene propylene material, a perfluoroalkoxy alkane material, a modified PTFE material, or a combination thereof.

## Embodiment 8

The low friction bearing liner of embodiment 1, wherein the second outer layer comprises a polytetrafluoroethylene material or a mixture of a polytetrafluoroethylene material



**17**

and a fluorinated ethylene propylene material, a perfluoroalkoxy alkane material, a modified PTFE material.

## Embodiment 9

The low friction bearing liner of embodiment 1, wherein the first inner layer comprises at least one of a fluorinated ethylene propylene material, a perfluoroalkoxy alkane material, a modified PTFE material, or a combination thereof.

## Embodiment 10

The low friction bearing liner of embodiment 1, wherein the second inner layer comprises a polytetrafluoroethylene material or a mixture of a polytetrafluoroethylene material and a fluorinated ethylene propylene material, a perfluoroalkoxy alkane material, a modified PTFE material.

## Embodiment 11

The low friction bearing liner of any one of embodiments 1 and 2, further comprising a wear rating of at least about 32,000, where the wear rating is equal to the number of rotations completed before failure in a Tribometer Test and failure is defined as a 50% increase in COF versus steady-state value during the Tribometer test, or at least about 35,000 or at least about 40,000 or at least about 45,000 or at least about 50,000 or at least about 75,000 or at least about 100,000 or at least about 125,000 or at least about 150,000 or at least about 175,000 or at least about 200,000 or at least about 225,000 or at least about 250,000.

## Embodiment 12

The low friction bearing liner of any one of embodiments 1 and 2, wherein the core layer consists of a polyimide material.

## Embodiment 13

The low friction bearing liner of any one of embodiments 1 and 2, wherein the first outer layer consists of a fluorinated ethylene propylene material.

## Embodiment 14

The low friction bearing liner of any one of embodiments 1 and 2, wherein the second outer layer consists of a polytetrafluoroethylene material.

## Embodiment 15

The low friction bearing liner of any one of embodiments 1 and 2, wherein the first inner layer consists of a fluorinated ethylene propylene material.

## Embodiment 16

The low friction bearing liner of any one of embodiments 1 and 2, wherein the second inner layer consists of a polytetrafluoroethylene material.

## Embodiment 17

The low friction bearing liner of any one of embodiments 1 and 2, wherein the first outer layer contacts the first surface of the core layer.

**18**

## Embodiment 18

The low friction bearing liner of any one of embodiments 1 and 2, wherein the first outer layer is bonded to the first surface of the core layer.

## Embodiment 19

The low friction bearing liner of any one of embodiments 1 and 2, wherein the second outer layer contacts the first outer layer.

## Embodiment 20

The low friction bearing liner of any one of embodiments 1 and 2, wherein the second outer layer is bonded to the first outer layer.

## Embodiment 21

The low friction bearing liner of any one of embodiments 1 and 2, wherein the first inner layer contacts the first surface of the core layer.

## Embodiment 22

The low friction bearing liner of any one of embodiments 1 and 2, wherein the first inner layer is bonded to the first surface of the core layer.

## Embodiment 23

The low friction bearing liner of any one of embodiments 1 and 2, wherein the second inner layer contacts the first outer layer.

## Embodiment 24

The low friction bearing liner of any one of embodiments 1 and 2, wherein the second inner layer is bonded to the first outer layer.

## Embodiment 25

The low friction bearing liner of any one of embodiments 1 and 2, further comprising a first outer layer thickness ratio  $FOL_T/CL_T$  of at least about 0.02, where  $FOL_T$  is equal to the thickness of the first outer layer and  $CL_T$  is equal to the thickness of the core layer, at least about 0.03 or at least about 0.04 or at least about 0.05 or at least about 0.06 or at least about 0.07 or at least about 0.08 or at least about 0.09.

## Embodiment 26

The low friction bearing liner of any one of embodiments 1 and 2, further comprising a first outer layer thickness ratio  $FOL_T/CL_T$  of not greater than about 0.4, where  $FOL_T$  is equal to the thickness of the first outer layer and  $CL_T$  is equal to the thickness of the core layer, not greater than about 0.3 or not greater than about 0.2 or not greater than about 0.19 or not greater than about 0.18 or not greater than about 0.17 or not greater than about 0.16 or not greater than about 0.15 or not greater than about 0.14 or not greater than about 0.13 or not greater than about 0.12 or not greater than about 0.11.

## Embodiment 27

The low friction bearing liner of any one of embodiments 1 and 2, further comprising a second outer layer thickness







**21**

about 6.5  $\mu\text{m}$  or not greater than about 6.0  $\mu\text{m}$  or not greater than about 5.5  $\mu\text{m}$  or not greater than about 5.1  $\mu\text{m}$ .

## Embodiment 39

The low friction bearing liner of any one of embodiments 1 and 2, wherein the first inner layer has a thickness of at least about 1  $\mu\text{m}$  or at least about 1.5  $\mu\text{m}$  or at least about 2.0  $\mu\text{m}$  or at least about 2.5  $\mu\text{m}$  or at least about 3.0  $\mu\text{m}$  or at least about 3.5  $\mu\text{m}$  or at least about 4.0  $\mu\text{m}$  or at least about 4.5  $\mu\text{m}$  or at least about 4.9  $\mu\text{m}$ .

## Embodiment 40

The low friction bearing liner of any one of embodiments 1 and 2, wherein the first inner layer has a thickness of not greater than about 10  $\mu\text{m}$  or not greater than about 9.5  $\mu\text{m}$  or not greater than about 9.0  $\mu\text{m}$  or not greater than about 8.5  $\mu\text{m}$  or not greater than about 8.0  $\mu\text{m}$  or not greater than about 7.5  $\mu\text{m}$  or not greater than about 7.0  $\mu\text{m}$  or not greater than about 6.5  $\mu\text{m}$  or not greater than about 6.0  $\mu\text{m}$  or not greater than about 5.5  $\mu\text{m}$  or not greater than about 5.1  $\mu\text{m}$ .

## Embodiment 41

The low friction bearing liner of any one of embodiments 1 and 2, wherein the second inner layer has a thickness of at least about 1  $\mu\text{m}$  or at least about 1.5  $\mu\text{m}$  or at least about 2.0  $\mu\text{m}$  or at least about 2.5  $\mu\text{m}$  or at least about 3.0  $\mu\text{m}$  or at least about 3.5  $\mu\text{m}$  or at least about 4.0  $\mu\text{m}$  or at least about 4.5  $\mu\text{m}$  or at least about 4.9  $\mu\text{m}$ .

## Embodiment 42

The low friction bearing liner of any one of embodiments 1 and 2, wherein the second inner layer has a thickness of not greater than about 10  $\mu\text{m}$  or not greater than about 9.5  $\mu\text{m}$  or not greater than about 9.0  $\mu\text{m}$  or not greater than about 8.5  $\mu\text{m}$  or not greater than about 8.0  $\mu\text{m}$  or not greater than about 7.5  $\mu\text{m}$  or not greater than about 7.0  $\mu\text{m}$  or not greater than about 6.5  $\mu\text{m}$  or not greater than about 6.0  $\mu\text{m}$  or not greater than about 5.5  $\mu\text{m}$  or not greater than about 5.1  $\mu\text{m}$ .

## Embodiment 43

The low friction bearing liner of any one of embodiments 1 and 2, wherein the low friction bearing liner has a thickness of at least about 10  $\mu\text{m}$  or at least about 15  $\mu\text{m}$  or at least about 20  $\mu\text{m}$  or at least about 25  $\mu\text{m}$  or at least about 30  $\mu\text{m}$  or at least about 35  $\mu\text{m}$  or at least about 40  $\mu\text{m}$  or at least about 45  $\mu\text{m}$  or at least about 50  $\mu\text{m}$  or at least about 55  $\mu\text{m}$  or at least about 60  $\mu\text{m}$  or at least about 65  $\mu\text{m}$  or even at least about 69  $\mu\text{m}$ .

## Embodiment 44

The low friction bearing liner of any one of embodiments 1 and 2, wherein the low friction bearing liner has a thickness of not greater than about 200  $\mu\text{m}$  or not greater than about 195  $\mu\text{m}$  or not greater than about 190  $\mu\text{m}$  or not greater than about 185  $\mu\text{m}$  or not greater than about 180  $\mu\text{m}$  or not greater than about 175  $\mu\text{m}$  or even not greater than about 170  $\mu\text{m}$  or not greater than about 165  $\mu\text{m}$  or not greater than about 160  $\mu\text{m}$  or not greater than about 155  $\mu\text{m}$  or not greater than about 150  $\mu\text{m}$  or not greater than about 145  $\mu\text{m}$  or not greater than about 140  $\mu\text{m}$  or not greater than about 135  $\mu\text{m}$  or not greater than about 130  $\mu\text{m}$  or not greater than

**22**

about 125  $\mu\text{m}$  or not greater than about 120  $\mu\text{m}$  or not greater than about 115  $\mu\text{m}$  or not greater than about 110  $\mu\text{m}$  or not greater than about 105  $\mu\text{m}$  or not greater than about 100  $\mu\text{m}$  or not greater than about 95  $\mu\text{m}$  or not greater than about 90  $\mu\text{m}$  or not greater than about 85  $\mu\text{m}$  or not greater than about 80  $\mu\text{m}$  or not greater than about 75  $\mu\text{m}$  or even not greater than about 71  $\mu\text{m}$ .

## Embodiment 45

A solenoid comprising: a barrel; an armature within the barrel; and a low friction bearing liner disposed between an inner surface of the barrel and an outer surface of the armature, wherein the low friction bearing liner comprises: a core layer comprising a polyimide material; a first outer layer overlying a first surface of the core layer, wherein the first outer layer comprises a fluoropolymer material, and wherein the first outer layer has a melt flow rate of at least about 2 g/10 min at 372° C.; a second outer layer overlying the first outer layer, wherein the second outer layer comprises a fluoropolymer material distinct from the fluoropolymer material of the first outer layer and wherein the first outer layer has a surface coefficient of friction of not greater than about 0.2; a first inner layer overlying a second surface of the core layer, wherein the second surface is opposite of the first surface, wherein the first inner layer comprises a fluoropolymer material, and wherein the first inner layer has a melt flow rate of at least about 2 g/10 min at 372° C.; and a second inner layer overlying the first inner layer, wherein the second inner layer comprises a fluoropolymer material distinct from the fluoropolymer material of the first inner layer and wherein the first inner layer has a surface coefficient of friction of not greater than about 0.2.

## Embodiment 46

A solenoid comprising: a barrel; an armature within the barrel; and a low friction bearing liner disposed between an inner surface of the barrel and an outer surface of the armature, wherein the low friction bearing liner comprises: a core layer comprising a polyimide material; a first outer layer overlying a first surface of the core layer, wherein the first outer layer comprises at least one of a fluorinated ethylene propylene material, a perfluoroalkoxy alkane material, a modified PTFE material, or a combination thereof; a second outer layer overlying the first outer layer, wherein the second outer layer comprises a polytetrafluoroethylene material or a mixture of a polytetrafluoroethylene material and a fluorinated ethylene propylene material, a perfluoroalkoxy alkane material, a modified PTFE material; a first inner layer overlying a second surface of the core layer, wherein the second surface is opposite of the first surface, wherein the first inner layer comprises at least one of a fluorinated ethylene propylene material, a perfluoroalkoxy alkane material, a modified PTFE material, or a combination thereof; and a second inner layer overlying the first inner layer, wherein the second inner layer comprises a polytetrafluoroethylene material or a mixture of a polytetrafluoroethylene material and a fluorinated ethylene propylene material, a perfluoroalkoxy alkane material, a modified PTFE material.

## Embodiment 47

The solenoid of any one of embodiments 45 and 46, wherein the low friction bearing liner is attached to the inner surface of the barrel.



**23**

## Embodiment 48

The solenoid of embodiment 46, wherein the first outer layer has a melt flow rate of at least about 2 g/10 min at 372° C.

## Embodiment 49

The solenoid of embodiment 46, wherein the first outer layer has a surface coefficient of friction of not greater than about 0.2.

## Embodiment 50

The solenoid of embodiment 46, wherein the first inner layer has a melt flow rate of at least about 2 g/10 min at 372° C.

## Embodiment 51

The solenoid of embodiment 46, wherein the first inner layer has a surface coefficient of friction of not greater than about 0.2.

## Embodiment 52

The solenoid of embodiment 45, wherein the first outer layer comprises at least one of a fluorinated ethylene propylene material, a perfluoroalkoxy alkane material, a modified PTFE material, or a combination thereof.

## Embodiment 53

The solenoid of embodiment 45, wherein the second outer layer comprises a polytetrafluoroethylene material or a mixture of a polytetrafluoroethylene material and a fluorinated ethylene propylene material, a perfluoroalkoxy alkane material, a modified PTFE material.

## Embodiment 54

The solenoid of embodiment 45, wherein the first inner layer comprises at least one of a fluorinated ethylene propylene material, a perfluoroalkoxy alkane material, a modified PTFE material, or a combination thereof.

## Embodiment 55

The solenoid of embodiment 45, wherein the second inner layer comprises a polytetrafluoroethylene material or a mixture of a polytetrafluoroethylene material and a fluorinated ethylene propylene material, a perfluoroalkoxy alkane material, a modified PTFE material.

## Embodiment 56

The solenoid of any one of embodiments 45 and 46, wherein low friction bearing liner comprises a wear rating of at least about 32,000, where the wear rating is equal to the number of rotations completed before failure in a Tribometer Test and failure is defined as a 50% increase in COF versus steady-state value during the Tribometer test, or at least about 35,000 or at least about 40,000 or at least about 45,000 or at least about 50,000 or at least about 75,000 or at least about 100,000 or at least about 125,000 or at least about

**24**

150,000 or at least about 175,000 or at least about 200,000 or at least about 225,000 or at least about 250,000.

## Embodiment 57

The solenoid of any one of embodiments 45 and 46, wherein the core layer consists of a polyimide material.

## Embodiment 58

The solenoid of any one of embodiments 45 and 46, wherein the first outer layer consists of a fluorinated ethylene propylene material.

## Embodiment 59

The solenoid of any one of embodiments 45 and 46, wherein the second outer layer consists of a polytetrafluoroethylene material.

## Embodiment 60

The solenoid of any one of embodiments 45 and 46, wherein the first inner layer consists of a fluorinated ethylene propylene material.

## Embodiment 61

The solenoid of any one of embodiments 45 and 46, wherein the second inner layer consists of a polytetrafluoroethylene material.

## Embodiment 62

The solenoid of any one of embodiments 45 and 46, wherein the first outer layer contacts the first surface of the core layer.

## Embodiment 63

The solenoid of any one of embodiments 45 and 46, wherein the first outer layer is bonded to the first surface of the core layer.

## Embodiment 64

The solenoid of any one of embodiments 45 and 46, wherein the second outer layer contacts the first outer layer.

## Embodiment 65

The solenoid of any one of embodiments 45 and 46, wherein the second outer layer is bonded to the first outer layer.

## Embodiment 66

The solenoid of any one of embodiments 45 and 46, wherein the first inner layer contacts the first surface of the core layer.

## Embodiment 67

The solenoid of any one of embodiments 45 and 46, wherein the first inner layer is bonded to the first surface of the core layer.







27

$\mu\text{m}$  or not greater than about 55  $\mu\text{m}$  or not greater than about 50  $\mu\text{m}$  or not greater than about 45  $\mu\text{m}$  or not greater than about 40  $\mu\text{m}$  or not greater than about 35  $\mu\text{m}$  or not greater than about 30  $\mu\text{m}$  or not greater than about 25  $\mu\text{m}$  or not greater than about 20  $\mu\text{m}$  or not greater than about 15  $\mu\text{m}$  or not greater than about 10  $\mu\text{m}$ .

Embodiment 80

The solenoid of any one of embodiments 45 and 46, wherein the first outer layer has a thickness of at least about 1  $\mu\text{m}$  or at least about 1.5  $\mu\text{m}$  or at least about 2.0  $\mu\text{m}$  or at least about 2.5  $\mu\text{m}$  or at least about 3.0  $\mu\text{m}$  or at least about 3.5  $\mu\text{m}$  or at least about 4.0  $\mu\text{m}$  or at least about 4.5  $\mu\text{m}$  or at least about 4.9  $\mu\text{m}$ .

Embodiment 81

The solenoid of any one of embodiments 45 and 46, wherein the first outer layer has a thickness of not greater than about 10  $\mu\text{m}$  or not greater than about 9.5  $\mu\text{m}$  or not greater than about 9.0  $\mu\text{m}$  or not greater than about 8.5  $\mu\text{m}$  or not greater than about 8.0  $\mu\text{m}$  or not greater than about 7.5  $\mu\text{m}$  or not greater than about 7.0  $\mu\text{m}$  or not greater than about 6.5  $\mu\text{m}$  or not greater than about 6.0  $\mu\text{m}$  or not greater than about 5.5  $\mu\text{m}$  or not greater than about 5.1  $\mu\text{m}$ .

Embodiment 82

The solenoid of any one of embodiments 45 and 46, wherein the second outer layer has a thickness of at least about 1  $\mu\text{m}$  or at least about 1.5  $\mu\text{m}$  or at least about 2.0  $\mu\text{m}$  or at least about 2.5  $\mu\text{m}$  or at least about 3.0  $\mu\text{m}$  or at least about 3.5  $\mu\text{m}$  or at least about 4.0  $\mu\text{m}$  or at least about 4.5  $\mu\text{m}$  or at least about 4.9  $\mu\text{m}$ .

Embodiment 83

The solenoid of any one of embodiments 45 and 46, wherein the second outer layer has a thickness of not greater than about 10  $\mu\text{m}$  or not greater than about 9.5  $\mu\text{m}$  or not greater than about 9.0  $\mu\text{m}$  or not greater than about 8.5  $\mu\text{m}$  or not greater than about 8.0  $\mu\text{m}$  or not greater than about 7.5  $\mu\text{m}$  or not greater than about 7.0  $\mu\text{m}$  or not greater than about 6.5  $\mu\text{m}$  or not greater than about 6.0  $\mu\text{m}$  or not greater than about 5.5  $\mu\text{m}$  or not greater than about 5.1  $\mu\text{m}$ .

Embodiment 84

The solenoid of any one of embodiments 45 and 46, wherein the first inner layer has a thickness of at least about 1  $\mu\text{m}$  or at least about 1.5  $\mu\text{m}$  or at least about 2.0  $\mu\text{m}$  or at least about 2.5  $\mu\text{m}$  or at least about 3.0  $\mu\text{m}$  or at least about 3.5  $\mu\text{m}$  or at least about 4.0  $\mu\text{m}$  or at least about 4.5  $\mu\text{m}$  or at least about 4.9  $\mu\text{m}$ .

Embodiment 85

The solenoid of any one of embodiments 45 and 46, wherein the first inner layer has a thickness of not greater than about 10  $\mu\text{m}$  or not greater than about 9.5  $\mu\text{m}$  or not greater than about 9.0  $\mu\text{m}$  or not greater than about 8.5  $\mu\text{m}$  or not greater than about 8.0  $\mu\text{m}$  or not greater than about 7.5  $\mu\text{m}$  or not greater than about 7.0  $\mu\text{m}$  or not greater than about 6.5  $\mu\text{m}$  or not greater than about 6.0  $\mu\text{m}$  or not greater than about 5.5  $\mu\text{m}$  or not greater than about 5.1  $\mu\text{m}$ .

28

Embodiment 86

The solenoid of any one of embodiments 45 and 46, wherein the second inner layer has a thickness of at least about 1  $\mu\text{m}$  or at least about 1.5  $\mu\text{m}$  or at least about 2.0  $\mu\text{m}$  or at least about 2.5  $\mu\text{m}$  or at least about 3.0  $\mu\text{m}$  or at least about 3.5  $\mu\text{m}$  or at least about 4.0  $\mu\text{m}$  or at least about 4.5  $\mu\text{m}$  or at least about 4.9  $\mu\text{m}$ .

Embodiment 87

The solenoid of any one of embodiments 45 and 46, wherein the second inner layer has a thickness of not greater than about 10  $\mu\text{m}$  or not greater than about 9.5  $\mu\text{m}$  or not greater than about 9.0  $\mu\text{m}$  or not greater than about 8.5  $\mu\text{m}$  or not greater than about 8.0  $\mu\text{m}$  or not greater than about 7.5  $\mu\text{m}$  or not greater than about 7.0  $\mu\text{m}$  or not greater than about 6.5  $\mu\text{m}$  or not greater than about 6.0  $\mu\text{m}$  or not greater than about 5.5  $\mu\text{m}$  or not greater than about 5.1  $\mu\text{m}$ .

Embodiment 88

The solenoid of any one of embodiments 45 and 46, wherein the low friction bearing liner has a thickness of at least about 10  $\mu\text{m}$  or at least about 15  $\mu\text{m}$  or at least about 20  $\mu\text{m}$  or at least about 25  $\mu\text{m}$  or at least about 30  $\mu\text{m}$  or at least about 35  $\mu\text{m}$  or at least about 40  $\mu\text{m}$  or at least about 45  $\mu\text{m}$  or at least about 50  $\mu\text{m}$  or at least about 55  $\mu\text{m}$  or at least about 60  $\mu\text{m}$  or at least about 65  $\mu\text{m}$  or even at least about 69  $\mu\text{m}$ .

Embodiment 89

The solenoid of any one of embodiments 45 and 46, wherein the low friction bearing liner has a thickness of not greater than about 200  $\mu\text{m}$  or not greater than about 195  $\mu\text{m}$  or not greater than about 190  $\mu\text{m}$  or not greater than about 185  $\mu\text{m}$  or not greater than about 180  $\mu\text{m}$  or not greater than about 175  $\mu\text{m}$  or even not greater than about 170  $\mu\text{m}$  or not greater than about 165  $\mu\text{m}$  or not greater than about 160  $\mu\text{m}$  or not greater than about 155  $\mu\text{m}$  or not greater than about 150  $\mu\text{m}$  or not greater than about 145  $\mu\text{m}$  or not greater than about 140  $\mu\text{m}$  or not greater than about 135  $\mu\text{m}$  or not greater than about 130  $\mu\text{m}$  or not greater than about 125  $\mu\text{m}$  or not greater than about 120  $\mu\text{m}$  or not greater than about 115  $\mu\text{m}$  or not greater than about 110  $\mu\text{m}$  or not greater than about 105  $\mu\text{m}$  or not greater than about 100  $\mu\text{m}$  or not greater than about 95  $\mu\text{m}$  or not greater than about 90  $\mu\text{m}$  or not greater than about 85  $\mu\text{m}$  or not greater than about 80  $\mu\text{m}$  or not greater than about 75  $\mu\text{m}$  or even not greater than about 71  $\mu\text{m}$ .

## EXAMPLES

The concepts described herein will be further described in the following Examples, which do not limit the scope of the invention described in the claims.

## Example 1

A sample low friction liner S1 was formed according to embodiments described herein. The sample low friction liner had a core layer of polyimide material with a thickness of 50  $\mu\text{m}$ . Both sides of the core layer were coated with layers of FEP material. The layers of FEP material both had a thickness of 5  $\mu\text{m}$ . Both outer sides of the FEP material



were then coated with layers of PTFE material. The layers of PTFE material both had a thickness of 5  $\mu\text{m}$ .

Two comparative sample low friction liners CS1 and CS2 were used for performance comparison. Comparative sample CS1 had a fabric core and was coated with a layer of cast PTFE. The total thickness of the comparative sample CS1 was 150  $\mu\text{m}$ . Comparative sample CS2 had a fabric core and was coated with a layer of modified PTFE. The total thickness of the comparative sample CS2 was 150  $\mu\text{m}$ .

Sample S1 and comparative samples CS1 were tested to determine their coefficient of frictions and wear rating using a Tribometer Test measured under a 9 newton normal force at 260 mm/sec in contact with a quarter inch polyimide wear sphere at a running temperature of 140° C. and lubricated with 6,000 cs silicone oil.

FIG. 3 includes a plot of the wear rotations vs. the coefficient of friction for the sample S1 and comparative samples CS1 and CS2. The results of the comparison tests are shown in table 1 below.

TABLE 1

| COF and Wear Life Comparison |       |             |
|------------------------------|-------|-------------|
| Sample                       | COF   | Wear Rating |
| S1                           | 0.023 | >250,000    |
| CS1                          | 0.034 | 9,700       |
| CS1                          | 0.040 | 29,500      |

Note that not all of the activities described above in the general description or the examples are required, that a portion of a specific activity may not be required, and that one or more further activities may be performed in addition to those described. Still further, the order in which activities are listed is not necessarily the order in which they are performed.

Benefits, other advantages, and solutions to problems have been described above with regard to specific embodiments. However, the benefits, advantages, solutions to problems, and any feature(s) that may cause any benefit, advantage, or solution to occur or become more pronounced are not to be construed as a critical, required, or essential feature of any or all the claims.

The specification and illustrations of the embodiments described herein are intended to provide a general understanding of the structure of the various embodiments. The specification and illustrations are not intended to serve as an exhaustive and comprehensive description of all of the elements and features of apparatus and systems that use the structures or methods described herein. Separate embodiments may also be provided in combination in a single embodiment, and conversely, various features that are, for brevity, described in the context of a single embodiment, may also be provided separately or in any subcombination. Further, reference to values stated in ranges includes each and every value within that range. Many other embodiments may be apparent to skilled artisans only after reading this specification. Other embodiments may be used and derived from the disclosure, such that a structural substitution, logical substitution, or another change may be made without departing from the scope of the disclosure. Accordingly, the disclosure is to be regarded as illustrative rather than restrictive.

What is claimed is:

1. A low friction bearing liner for a solenoid, wherein the low friction bearing liner comprises:

- a core layer comprising a polyimide material;
- a first outer layer overlying a first surface of the core layer, wherein the first outer layer comprises a fluoropolymer material, and wherein the first outer layer has a melt flow rate of at least about 2 g/10 min at 372° C.;
- a second outer layer overlying the first outer layer, wherein the second outer layer comprises a fluoropolymer material distinct from the fluoropolymer material of the first outer layer and wherein the first outer layer has a surface coefficient of friction of not greater than about 0.2;
- a first inner layer overlying a second surface of the core layer, wherein the second surface is opposite of the first surface, wherein the first inner layer comprises a fluoropolymer material, and wherein the first inner layer has a melt flow rate of at least about 2 g/10 min at 372° C.; and
- a second inner layer overlying the first inner layer, wherein the second inner layer comprises a fluoropolymer material distinct from the fluoropolymer material of the first inner layer and wherein the first inner layer has a surface coefficient of friction of not greater than about 0.2.

2. The low friction bearing liner of claim 1, wherein the first outer layer comprises at least one of a fluorinated ethylene propylene material, a perfluoroalkoxy alkane material, a modified PTFE material, or a combination thereof.

3. The low friction bearing liner of claim 1, wherein the second outer layer comprises a polytetrafluoroethylene material or a mixture of a polytetrafluoroethylene material and a fluorinated ethylene propylene material, a perfluoroalkoxy alkane material, a modified PTFE material.

4. The low friction bearing liner of claim 1, wherein the first inner layer comprises at least one of a fluorinated ethylene propylene material, a perfluoroalkoxy alkane material, a modified PTFE material, or a combination thereof.

5. The low friction bearing liner of claim 1, wherein the second inner layer comprises a polytetrafluoroethylene material or a mixture of a polytetrafluoroethylene material and a fluorinated ethylene propylene material, a perfluoroalkoxy alkane material, a modified PTFE material.

6. The low friction bearing liner of claim 1, comprising a wear rating of at least about 32,000, where the wear rating is equal to the number of rotations completed before failure in a Tribometer Test and failure is defined as a 50% increase in COF versus steady-state value during the Tribometer test.

7. The low friction bearing liner of claim 1, further comprising a first outer layer thickness ratio  $FOL_T/CL_T$  of at least about 0.02 and not greater than about 0.4, where  $FOL_T$  is equal to the thickness of the first outer layer and  $CL_T$  is equal to the thickness of the core layer.

8. The low friction bearing liner of claim 1, further comprising a second outer layer thickness ratio  $SOL_T/CL_T$  of at least about 0.02 and not greater than about 0.4, where  $SOL_T$  is equal to the thickness of the second outer layer and  $CL_T$  is equal to the thickness of the core layer.

9. The low friction bearing liner of claim 1, further comprising a first inner layer thickness ratio  $FIL_T/CL_T$  of at least about 0.02 and not greater than about 0.4, where  $FIL_T$  is equal to the thickness of the first inner layer and  $CL_T$  is equal to the thickness of the core layer, and a second inner layer thickness ratio  $SIL_T/CL_T$  of at least about 0.02 and not greater than about 0.4, where  $SIL_T$  is equal to the thickness of the second inner layer and  $CL_T$  is equal to the thickness of the core layer.