



US011140360B1

(12) **United States Patent**
Kasaba

(10) **Patent No.:** **US 11,140,360 B1**
(45) **Date of Patent:** **Oct. 5, 2021**

(54) **SYSTEM AND METHOD FOR AN INTERACTIVE DIGITALLY RENDERED AVATAR OF A SUBJECT PERSON**

(71) Applicant: **KNOW SYSTEMS CORP.**,
Middletown, DE (US)

(72) Inventor: **Michael E. Kasaba**, Malibu, CA (US)

(73) Assignee: **KNOW SYSTEMS CORP.**,
Middletown, DE (US)

(*) Notice: Subject to any disclaimer, the term of this patent is extended or adjusted under 35 U.S.C. 154(b) by 0 days.

(21) Appl. No.: **17/094,146**

(22) Filed: **Nov. 10, 2020**

(51) **Int. Cl.**
H04N 7/15 (2006.01)
G09B 5/14 (2006.01)
G06N 20/00 (2019.01)
G06K 9/00 (2006.01)
G06F 3/01 (2006.01)

(52) **U.S. Cl.**
CPC **H04N 7/157** (2013.01); **G06F 3/017** (2013.01); **G06K 9/00302** (2013.01); **G06K 9/00355** (2013.01); **G06N 20/00** (2019.01); **G09B 5/14** (2013.01)

(58) **Field of Classification Search**
USPC 348/14.01
See application file for complete search history.

(56) **References Cited**

U.S. PATENT DOCUMENTS

8,285,549 B2 10/2012 Teegan et al.
9,058,698 B2 6/2015 Jones et al.

9,318,113 B2 4/2016 Westby et al.
9,608,950 B2 3/2017 Geiger et al.
9,613,450 B2 4/2017 Wang et al.
9,716,674 B2 7/2017 Ciofalo et al.
9,959,368 B2 5/2018 Kolluru et al.
9,965,553 B2 5/2018 Lyren
9,996,963 B2 6/2018 Ray et al.
10,169,897 B1 1/2019 Geiger et al.
10,275,121 B1 4/2019 Geiger et al.
10,291,669 B2 5/2019 Dharmaji
10,313,403 B2 6/2019 Ciofalo et al.
10,362,219 B2 7/2019 Wlson et al.
10,523,898 B1 * 12/2019 Ward H04N 7/152

(Continued)

FOREIGN PATENT DOCUMENTS

EP 2849087 A1 3/2015
KR 10-2018-0093455 A 8/2018

(Continued)

Primary Examiner — Maria El-Zoobi

(74) *Attorney, Agent, or Firm* — Plumsea Law Group, LLC

(57) **ABSTRACT**

A system and method for an interactive digitally rendered avatar of a subject person during a video presentation is described. In one embodiment, the method includes transmitting a video presentation featuring a subject person to a plurality of users via a first communication format. The method also includes receiving from at least one user of the plurality of users during the video presentation, a request to initiate an interactive session with an avatar of the subject person. In response to the request, the method includes generating a first avatar of the subject person and initiating a first interactive session between the first avatar and the at least one user. The method further includes engaging in the first interactive session between the first avatar of the subject person and the at least one user via a second communication format that is different than the first communication format.

20 Claims, 14 Drawing Sheets

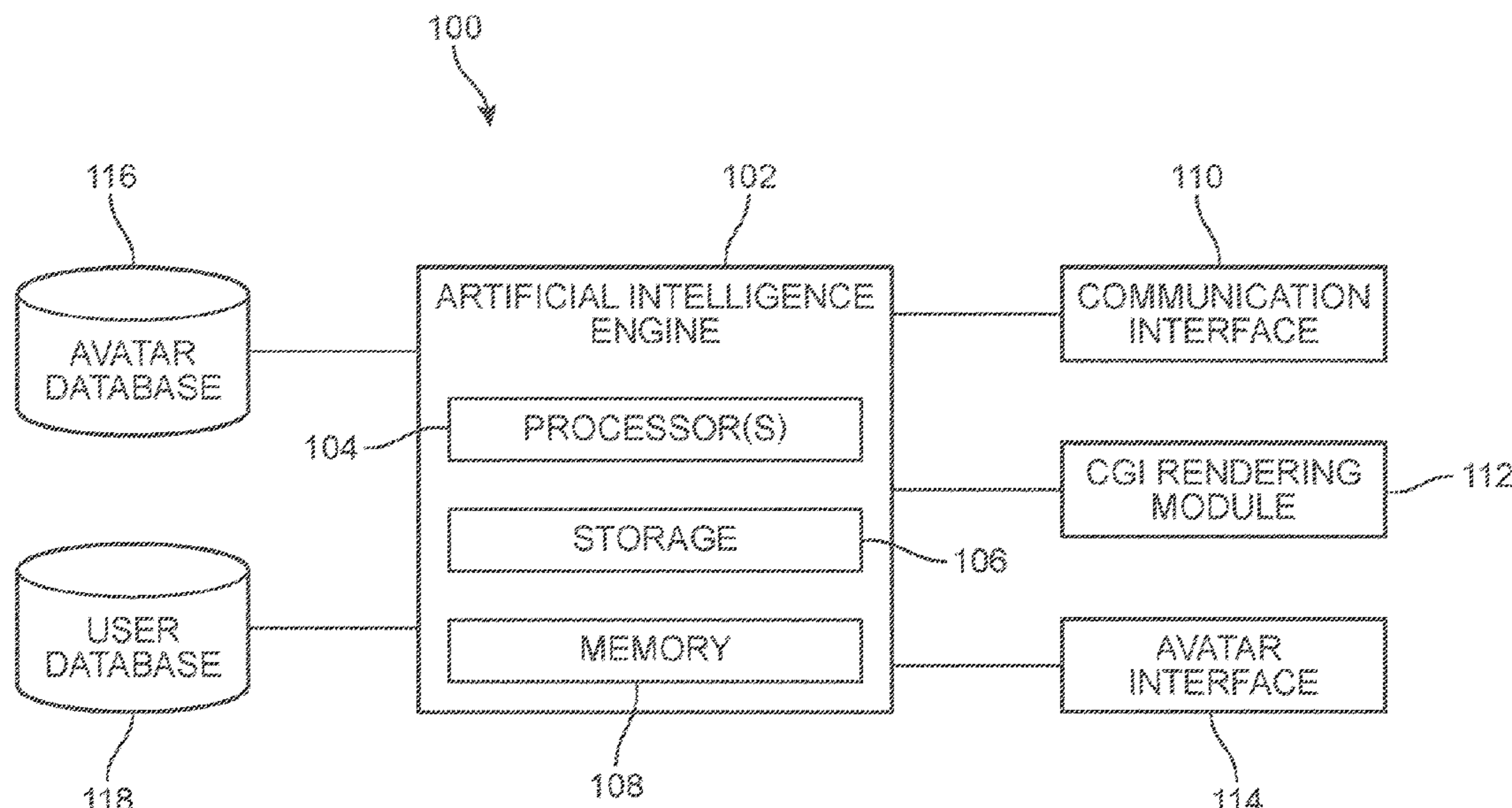

(56)

References Cited

U.S. PATENT DOCUMENTS

10,628,635 B1 4/2020 Carpenter, II et al.
10,679,626 B2 6/2020 Aarabi
10,706,347 B2 7/2020 Garcia
10,853,717 B2 12/2020 Abramson et al.
2002/0010584 A1 1/2002 Schultz et al.
2007/0165022 A1 7/2007 Peleg et al.
2009/0112680 A1 4/2009 Dovrath et al.
2011/0007079 A1 1/2011 Perez et al.
2013/0257877 A1 10/2013 Davis
2016/0134840 A1* 5/2016 McCulloch G06K 9/00208
348/14.03
2017/0018200 A1* 1/2017 Nemire G09B 7/02
2018/0061254 A1* 3/2018 Amigud G09B 5/00
2018/0350144 A1 12/2018 Rathod
2018/0359293 A1* 12/2018 Faulkner H04L 65/403
2019/0051032 A1 2/2019 Chu et al.
2019/0266774 A1 8/2019 Sommerlade et al.
2019/0333094 A1* 10/2019 Newell G06Q 30/0245
2020/0306640 A1 10/2020 Kolen et al.

FOREIGN PATENT DOCUMENTS

KR 10-1925440 B1 12/2018
KR 102035596 B1 10/2019
WO 2019036569 A1 2/2019

* cited by examiner

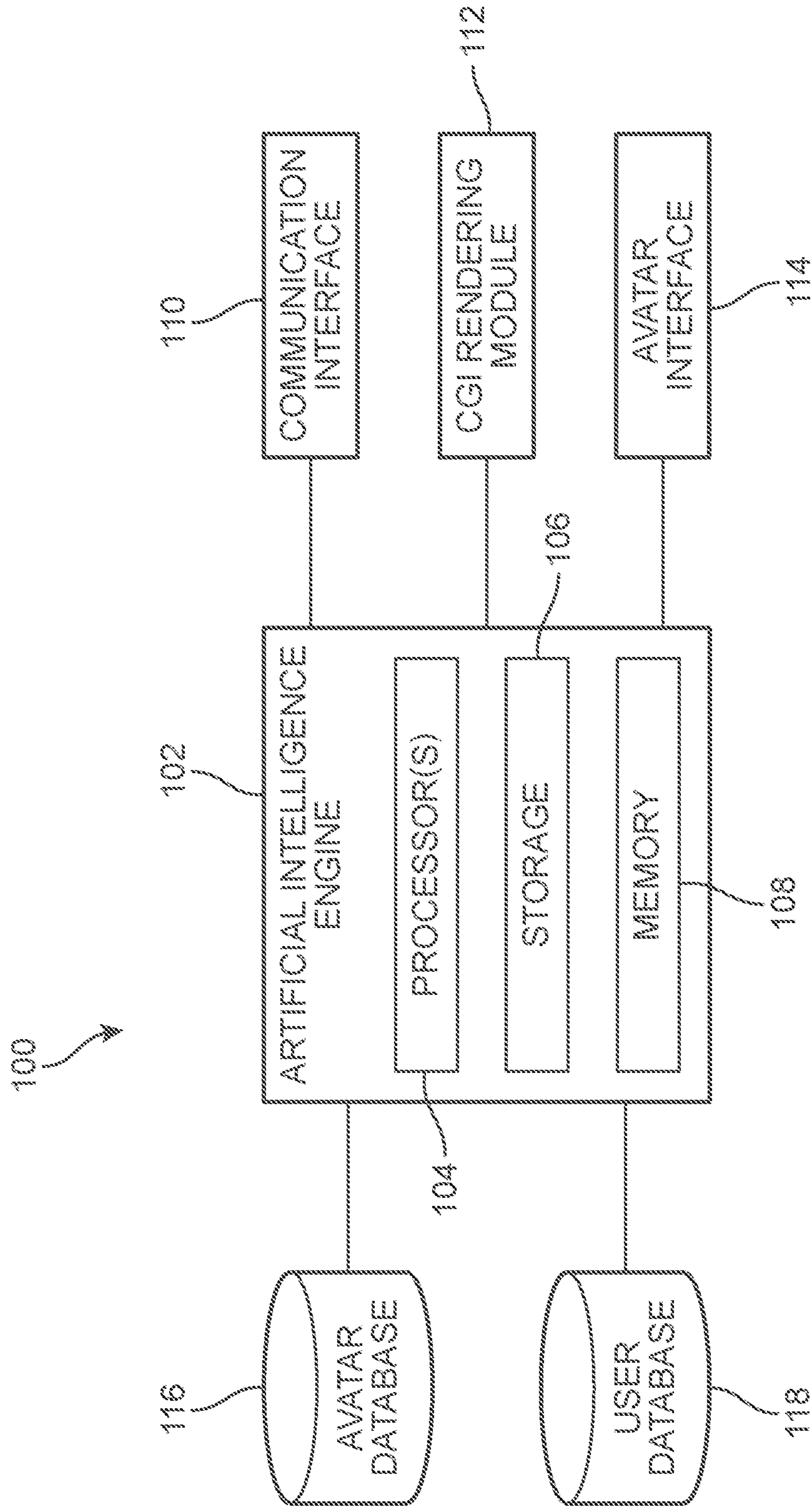

FIG. 1

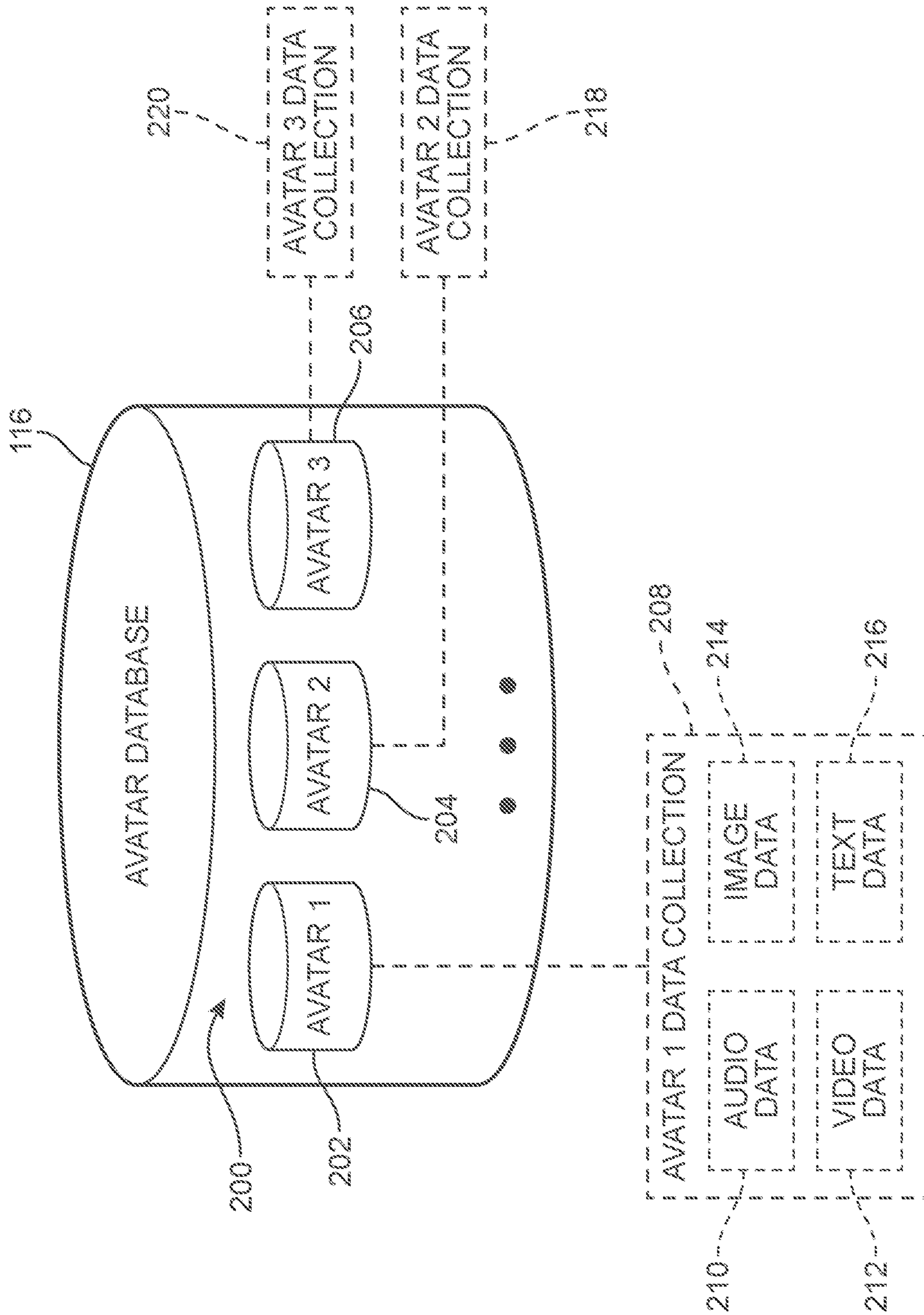

FIG. 2

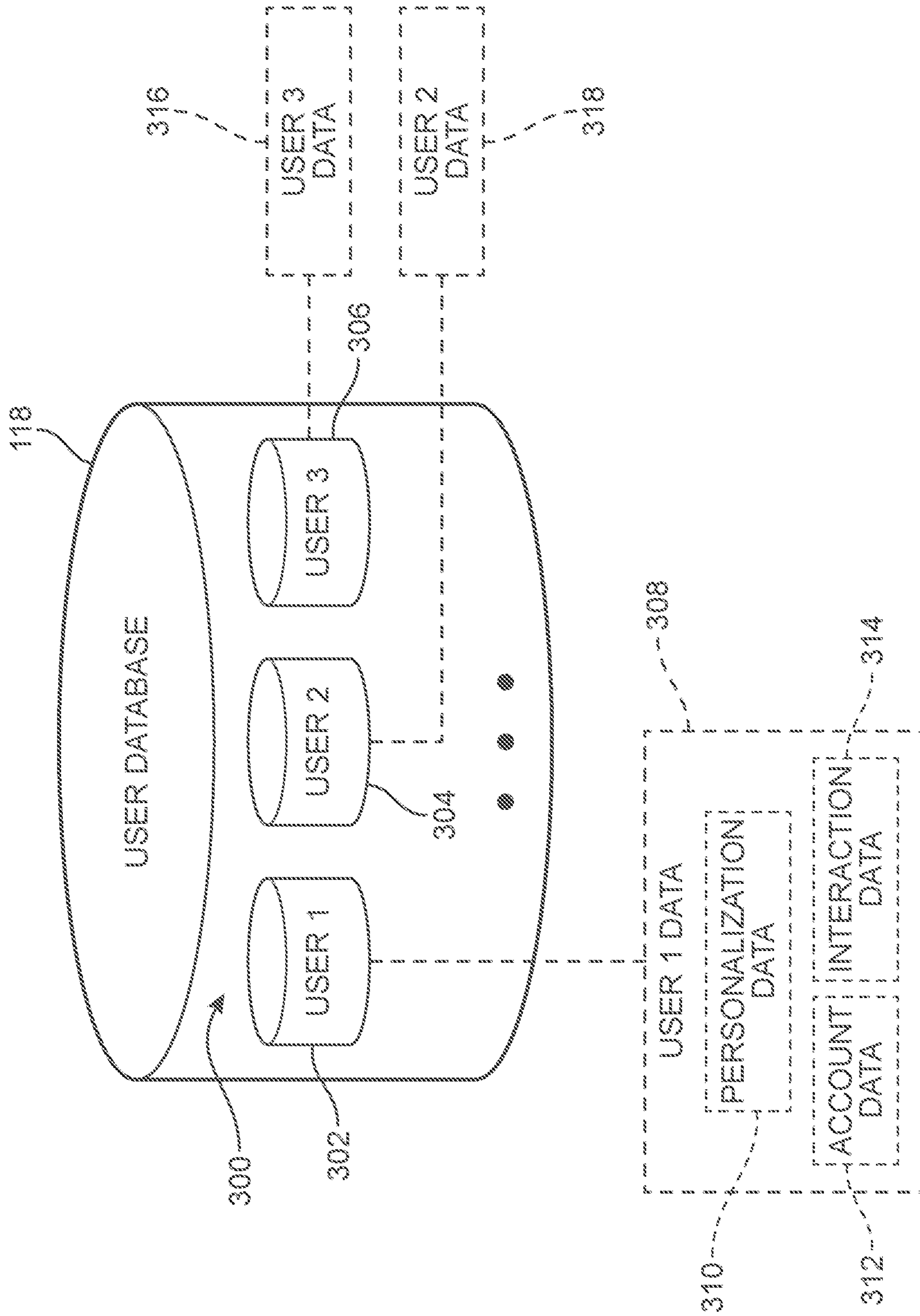

FIG. 3

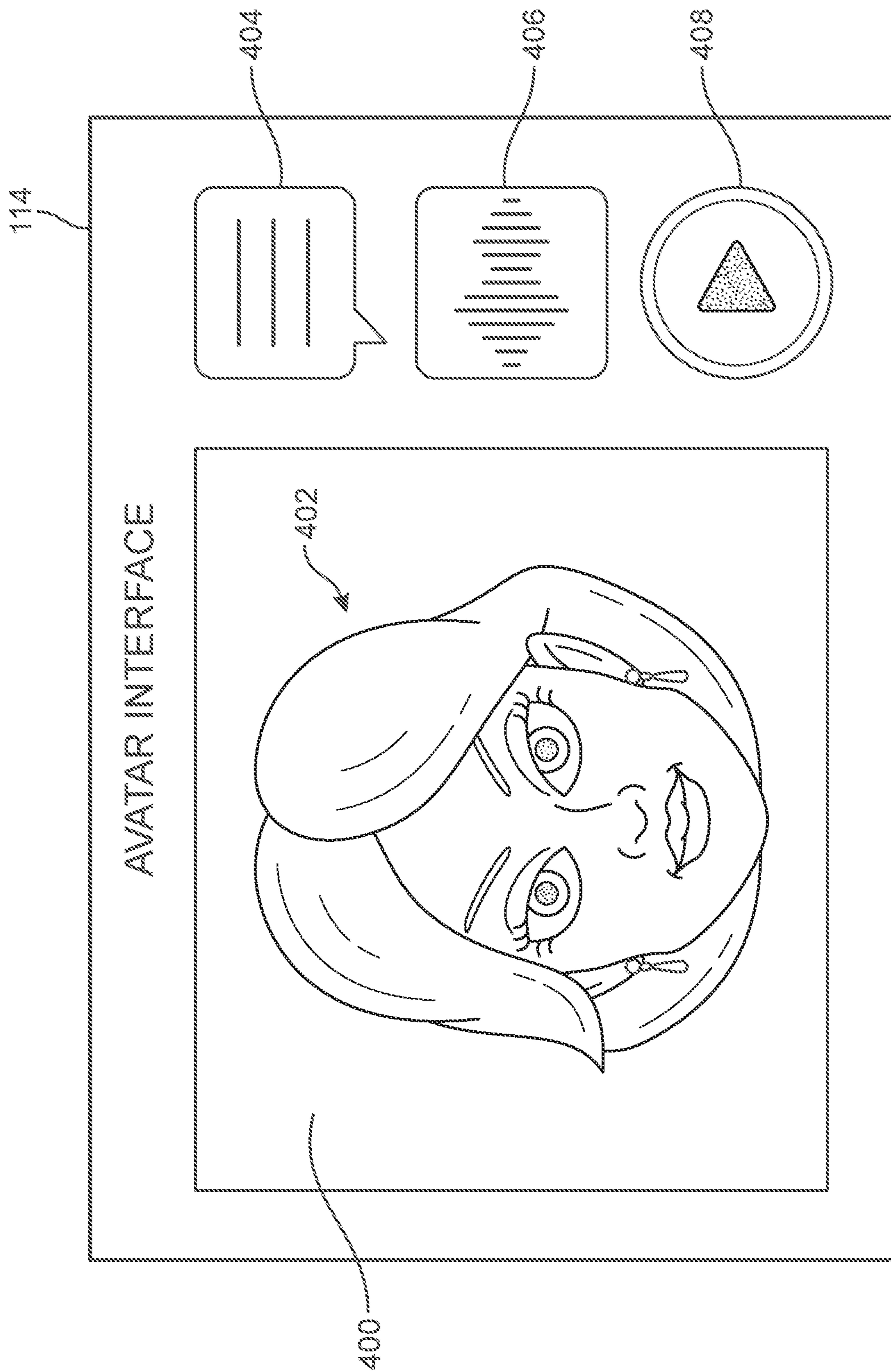

FIG. 4

5/14

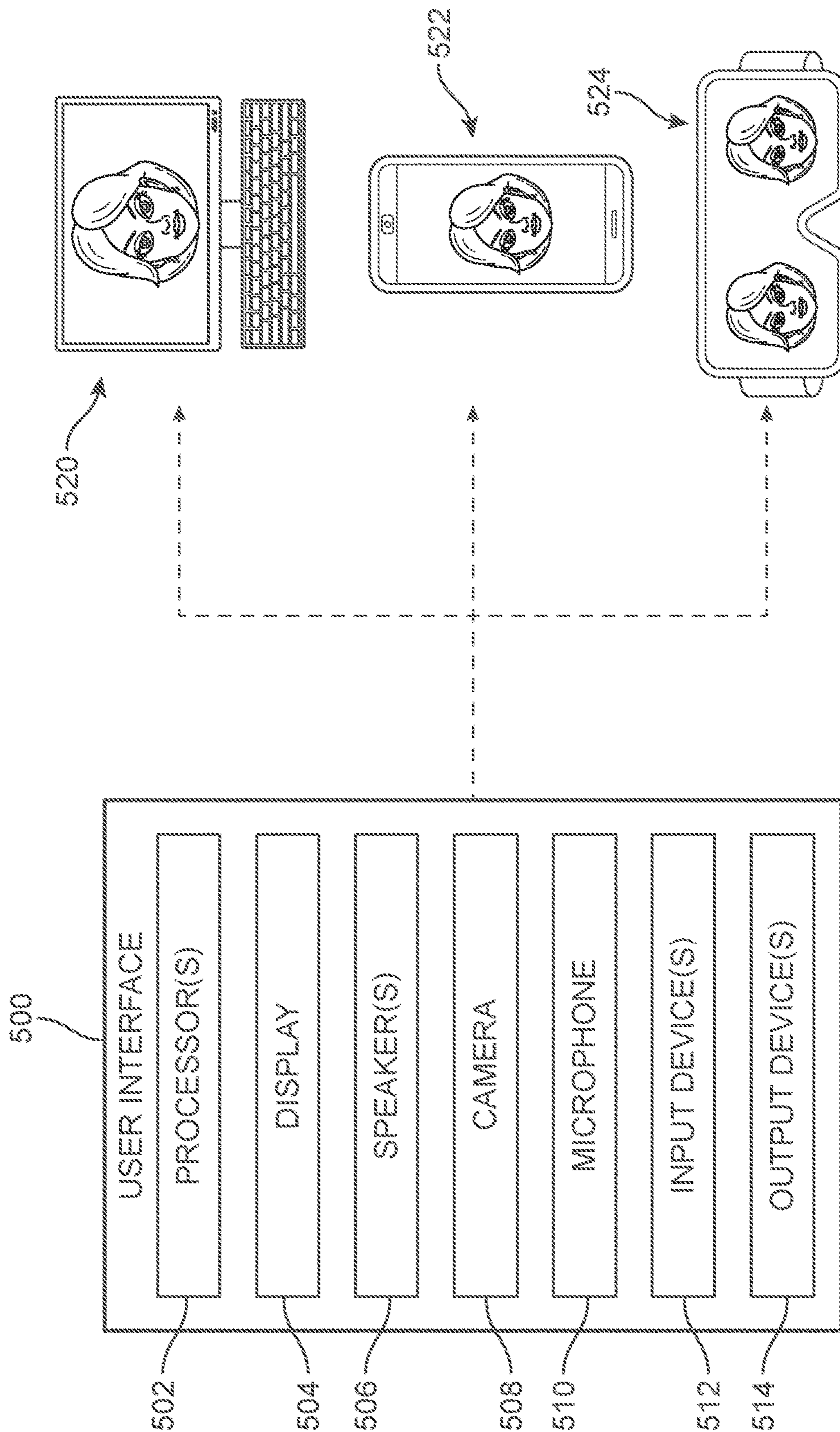

FIG. 5

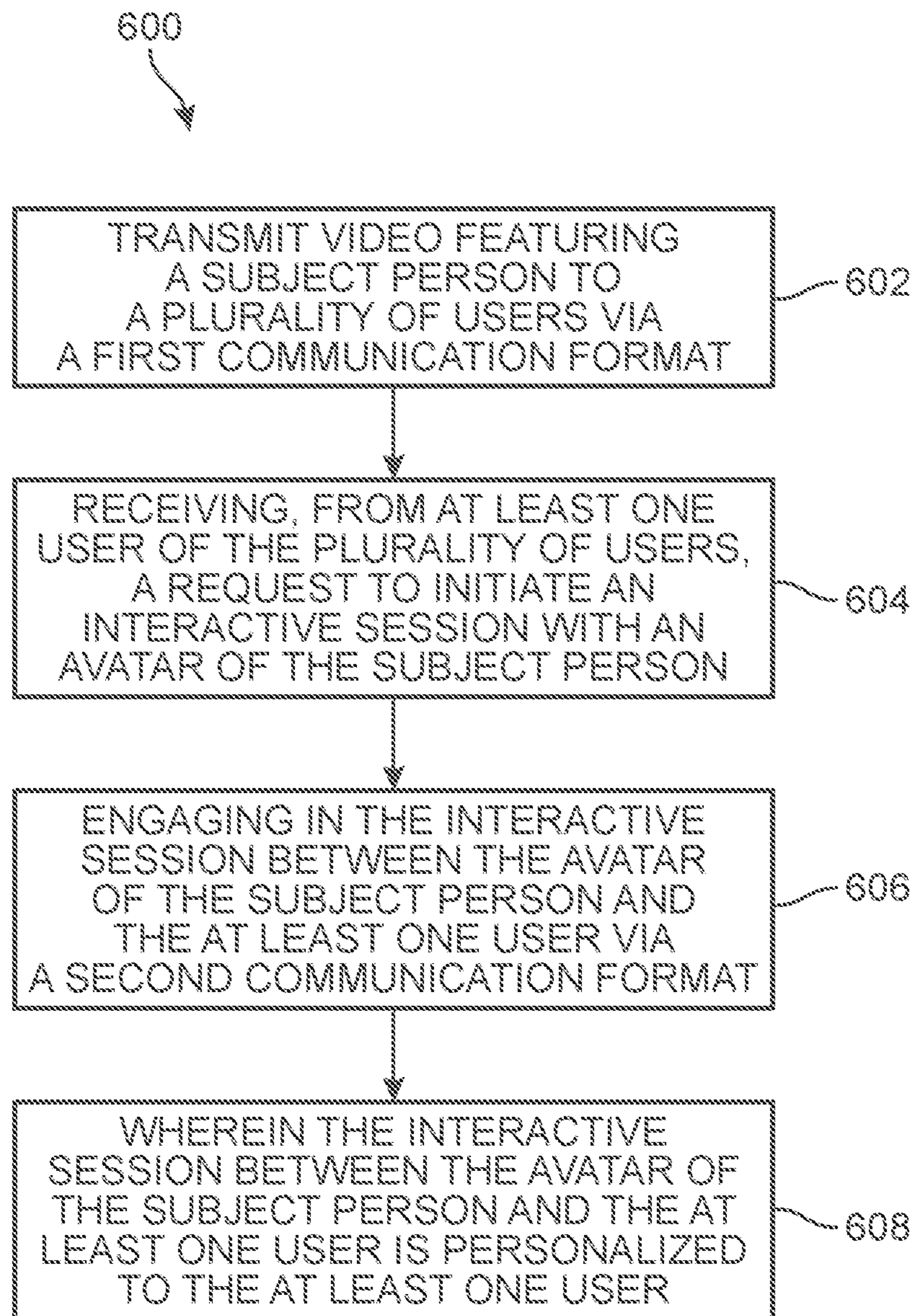

FIG. 6

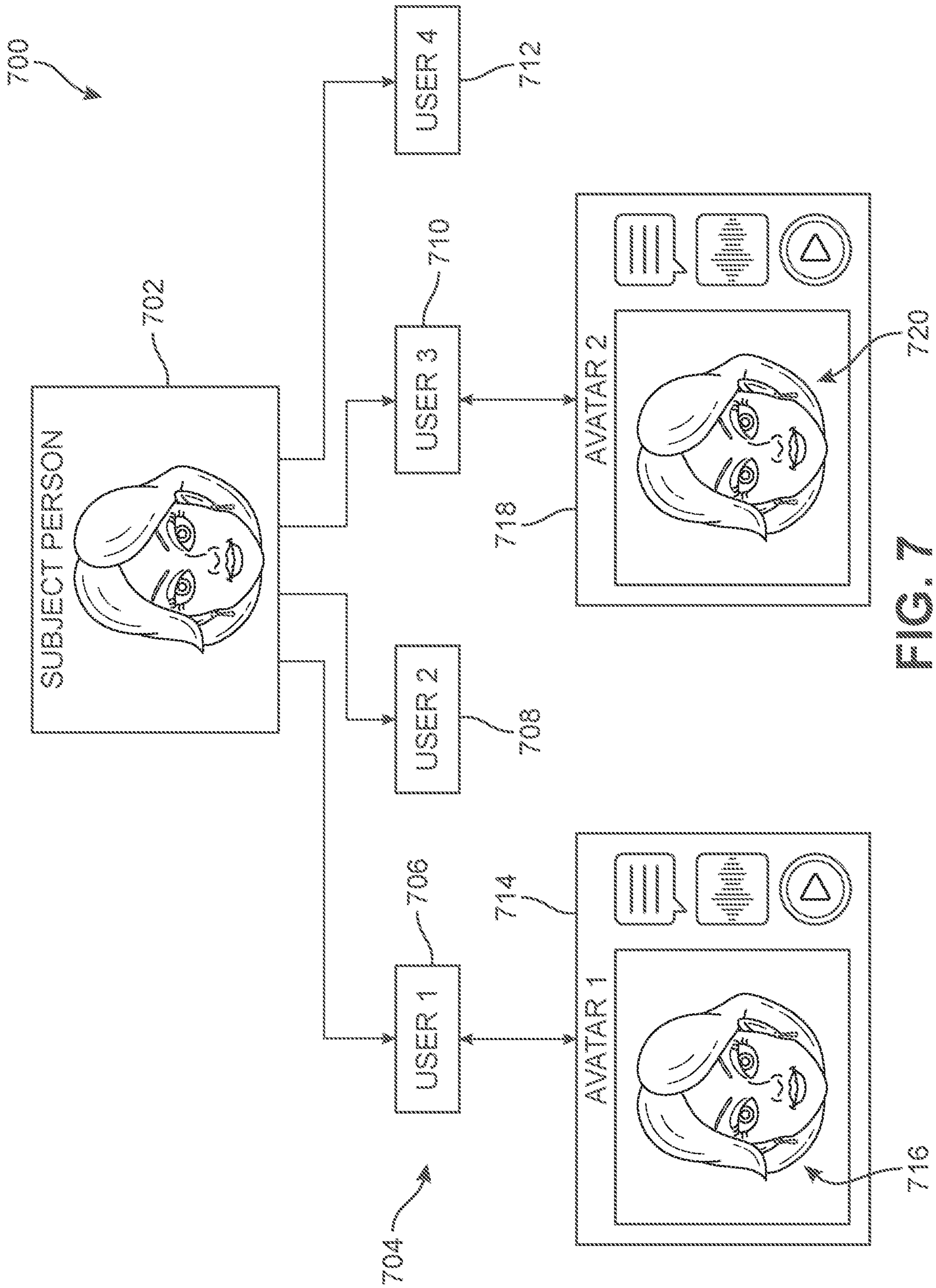

FIG. 7

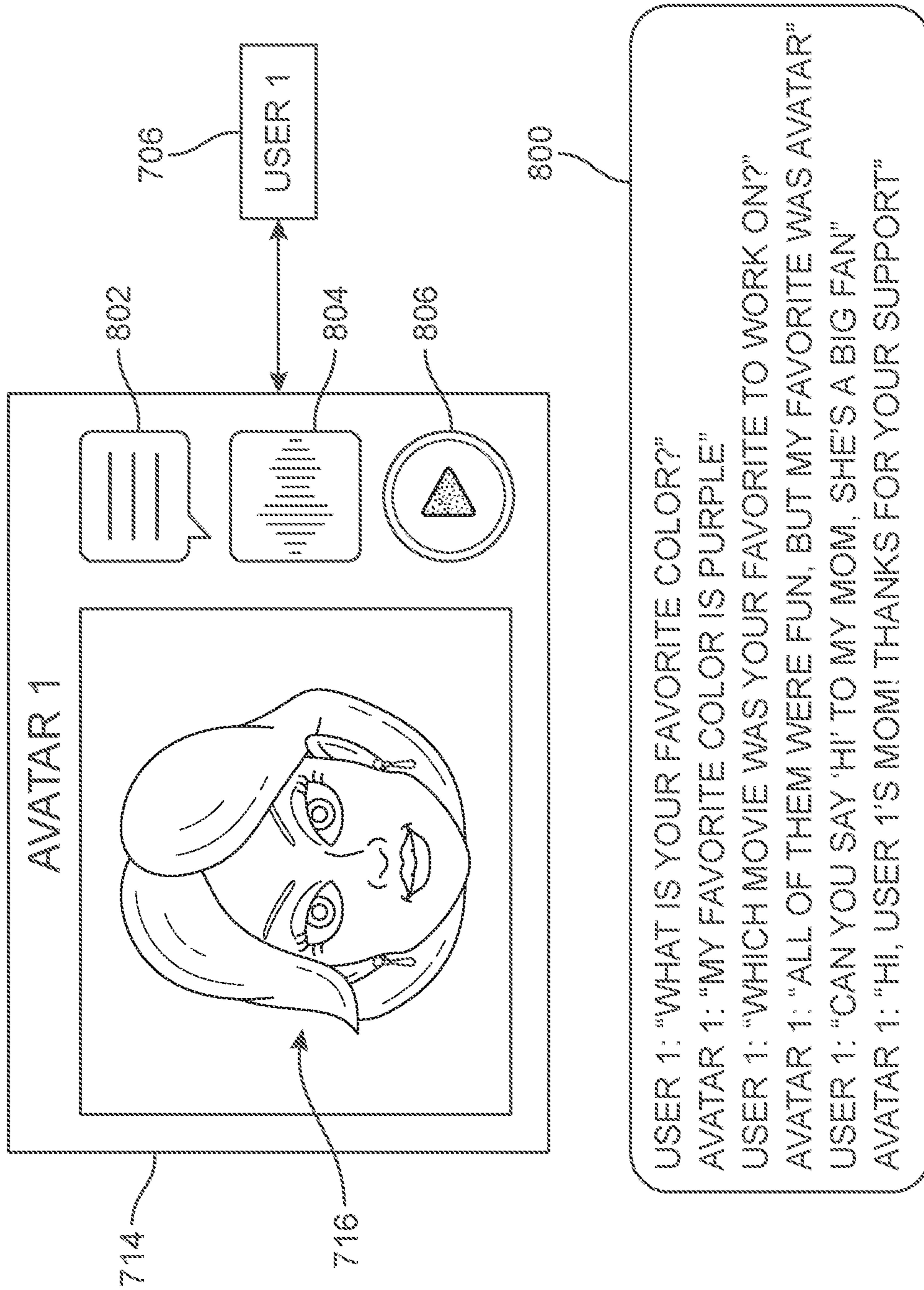

FIG. 8

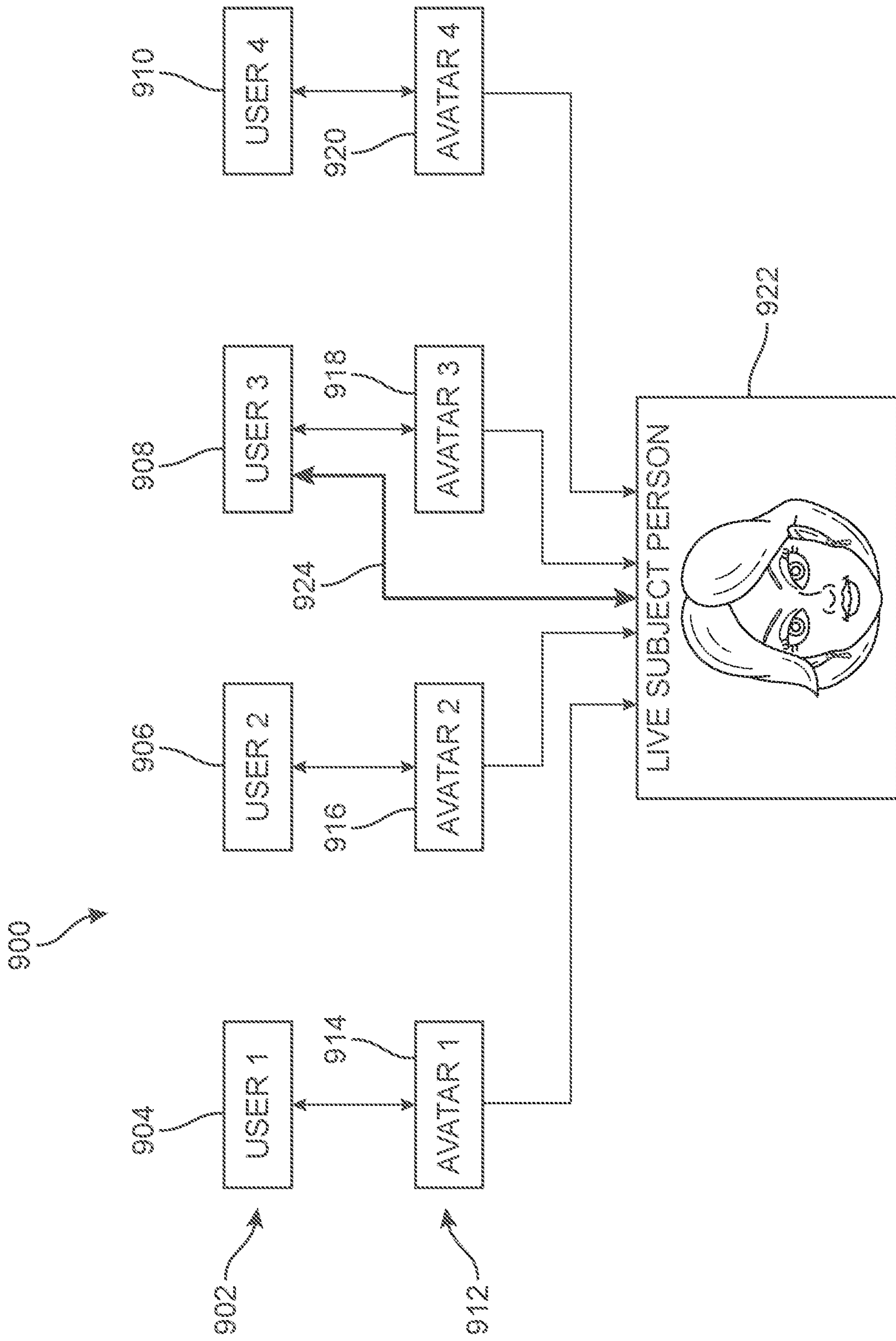

FIG. 9

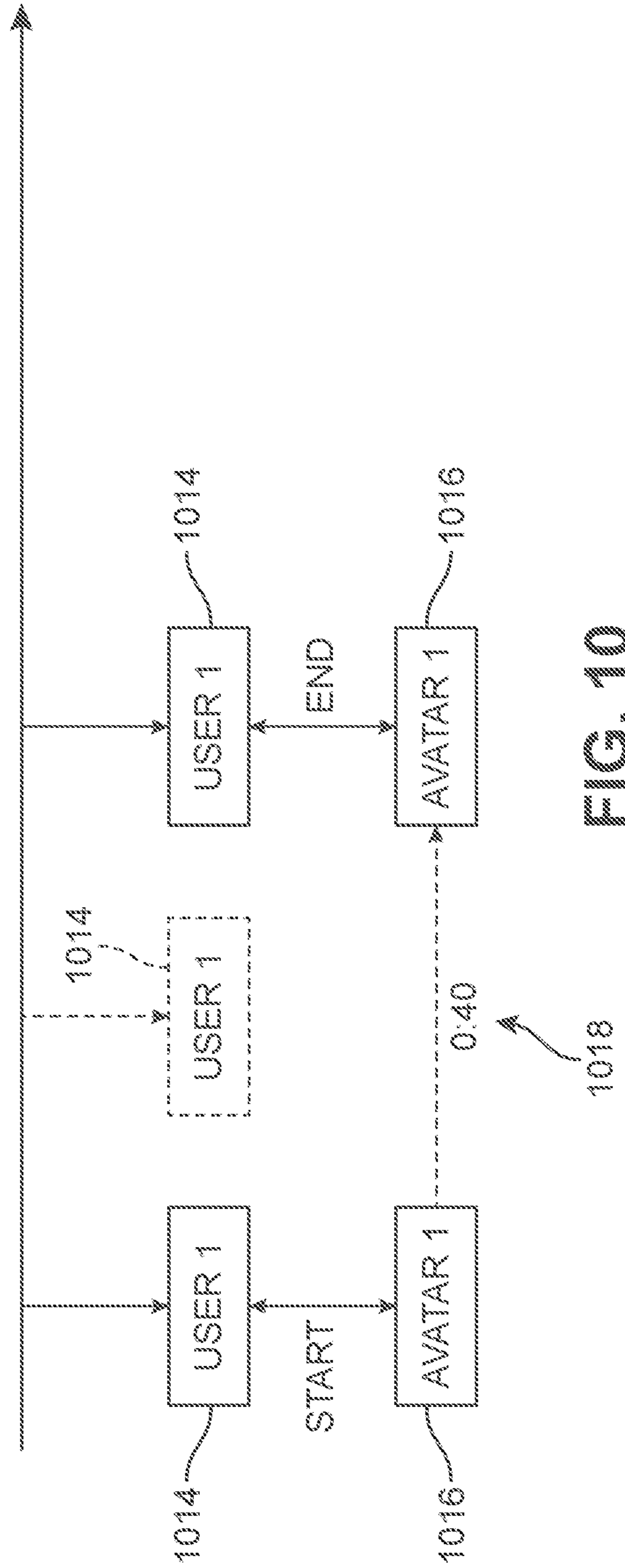
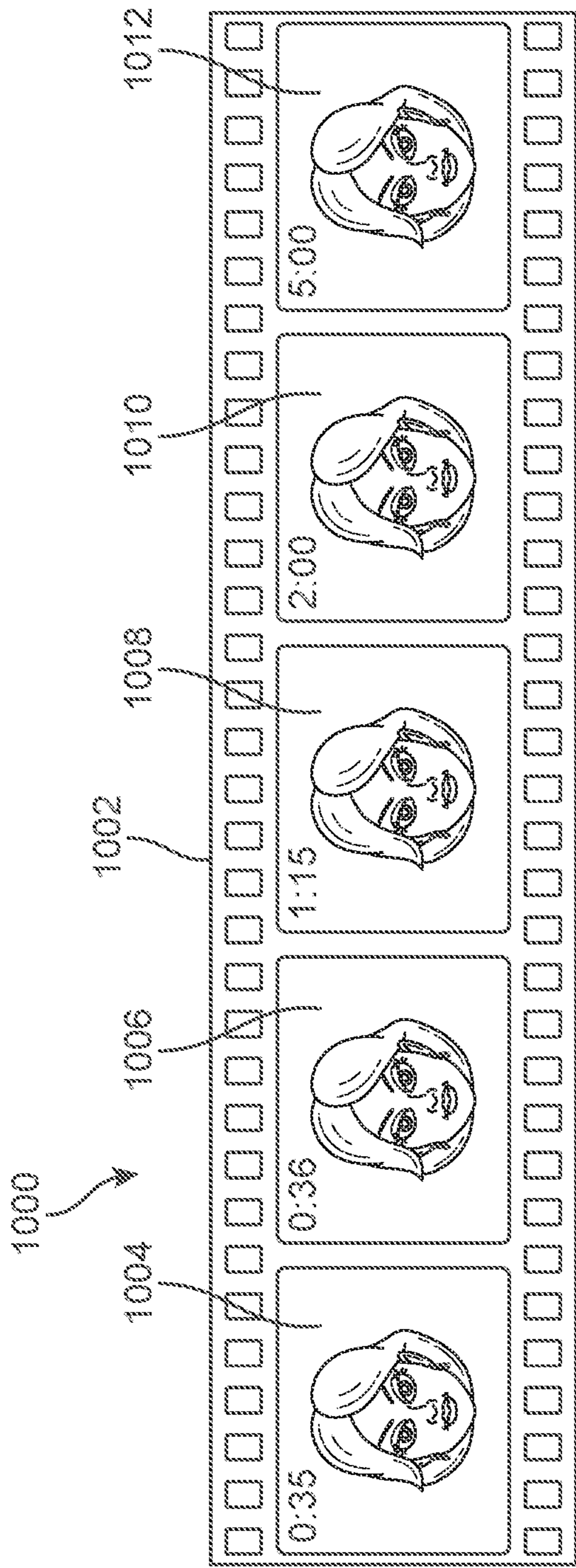

FIG. 10

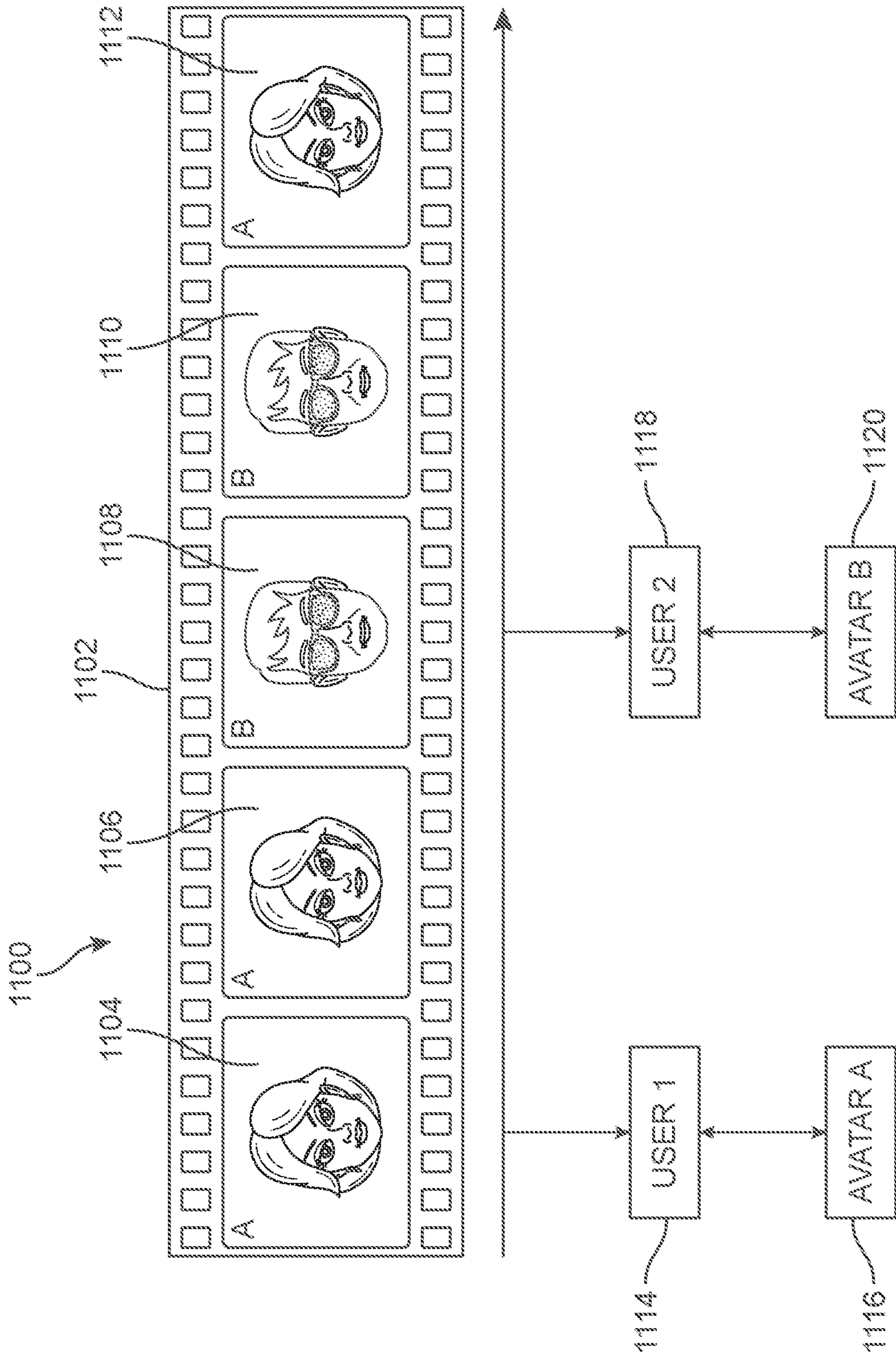

FIG. 11

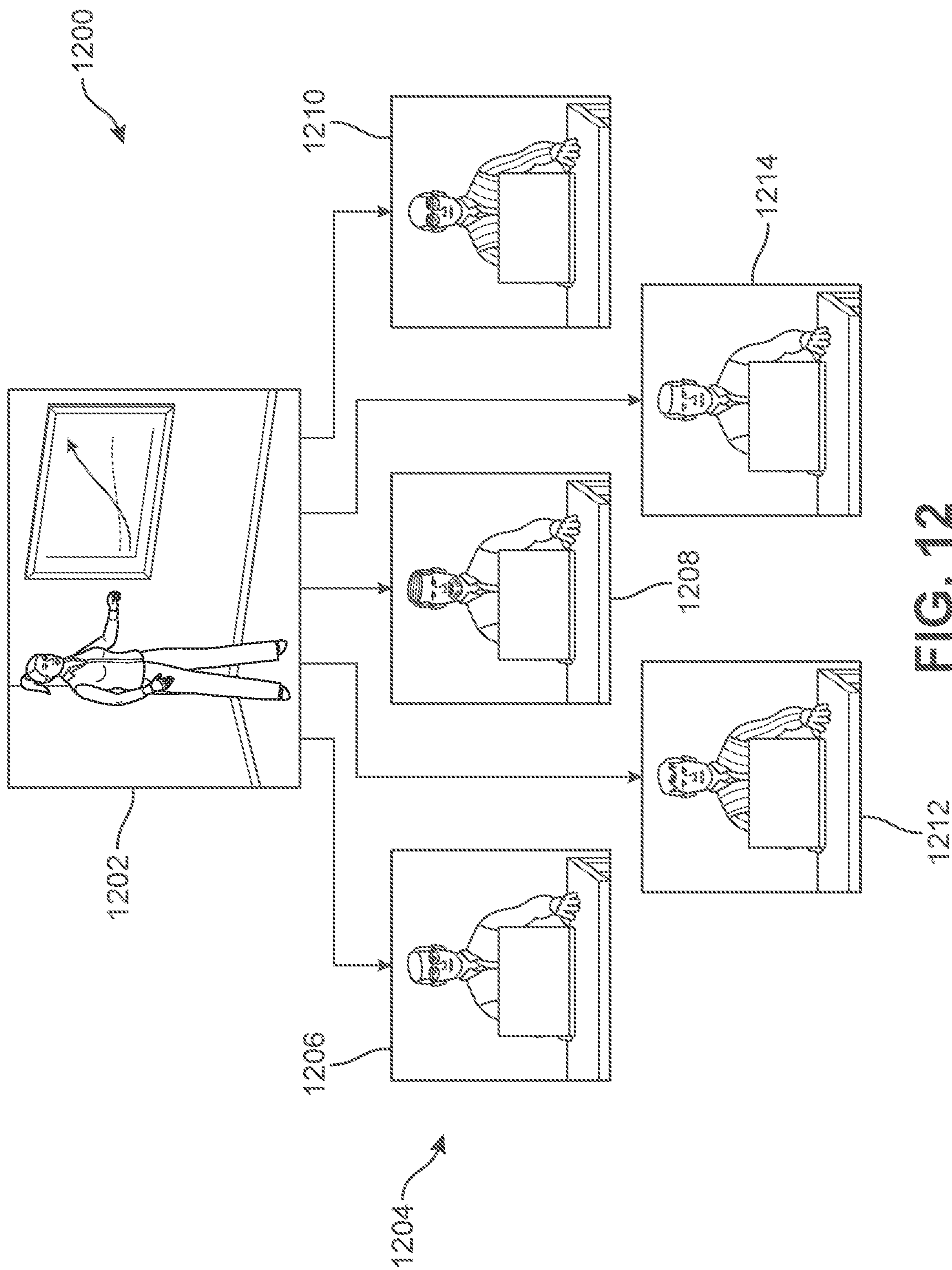

FIG. 12

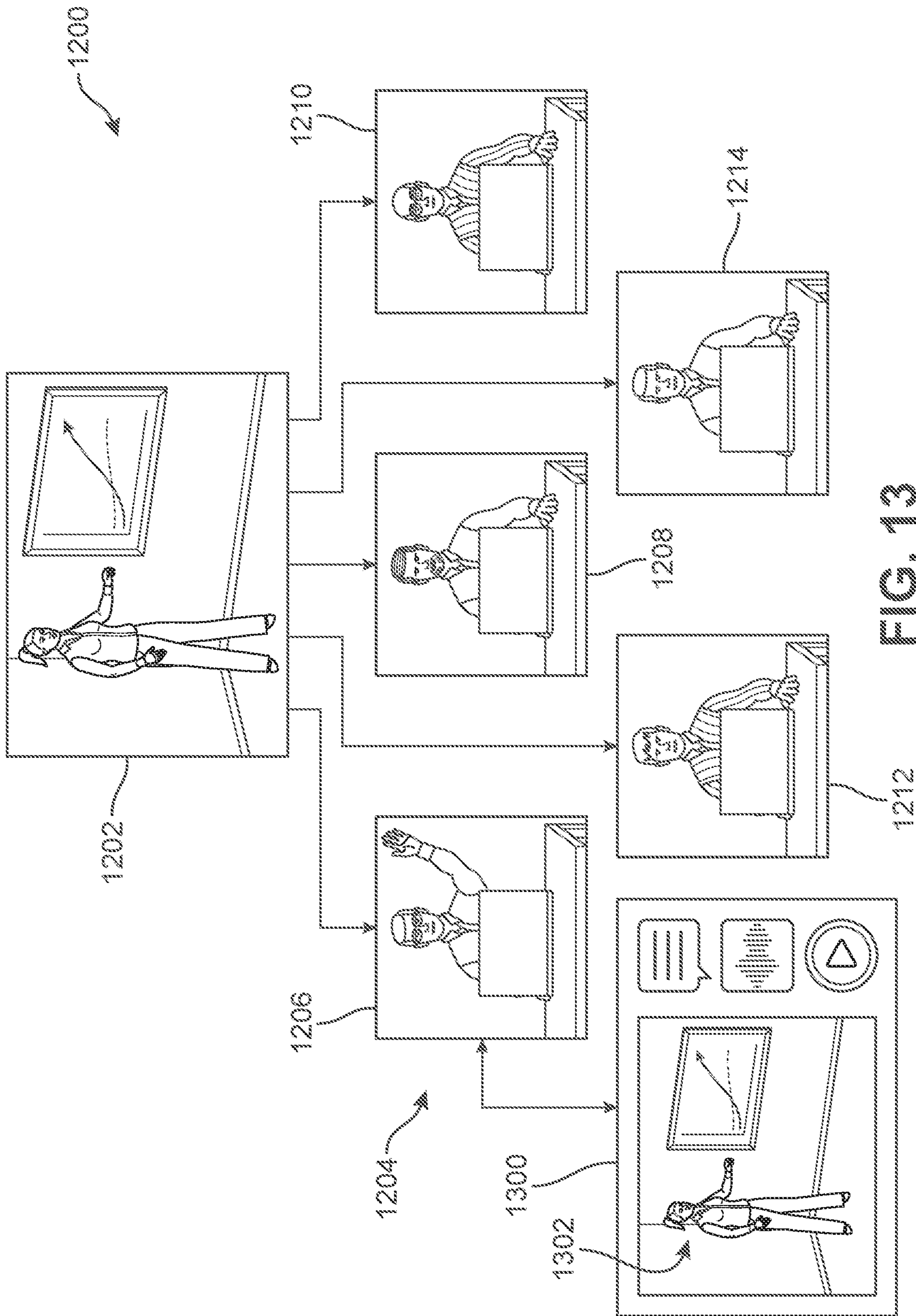
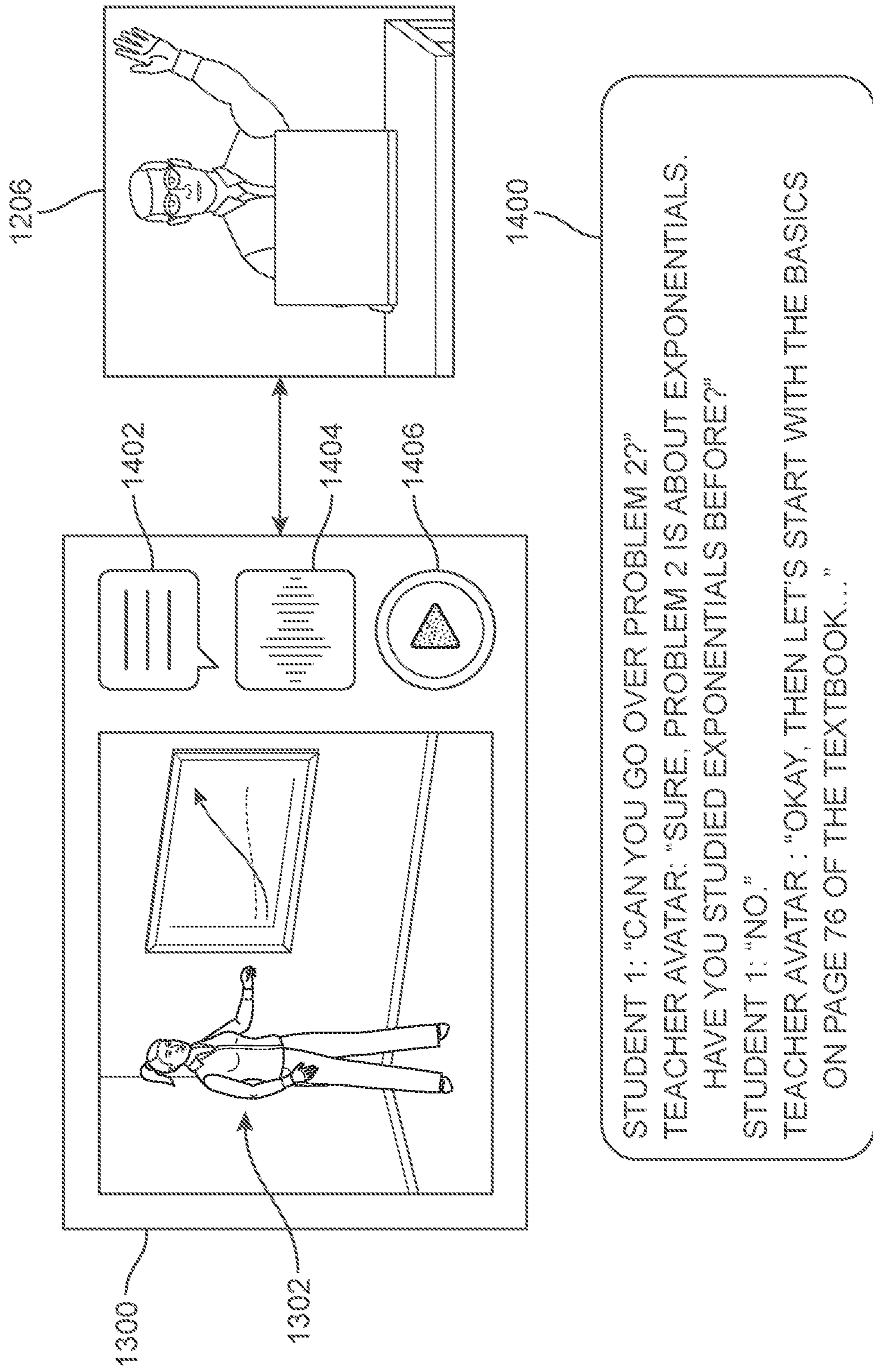

FIG. 13



STUDENT 1: "CAN YOU GO OVER PROBLEM 2?"
TEACHER AVATAR: "SURE, PROBLEM 2 IS ABOUT EXPONENTIALS.
HAVE YOU STUDIED EXPONENTIALS BEFORE?"
STUDENT 1: "NO."
TEACHER AVATAR : "OKAY, THEN LET'S START WITH THE BASICS
ON PAGE 76 OF THE TEXTBOOK..."

FIG. 14

1

**SYSTEM AND METHOD FOR AN
INTERACTIVE DIGITALLY RENDERED
AVATAR OF A SUBJECT PERSON**

BACKGROUND

The present disclosure generally relates to using an artificial intelligence system to digitally render an avatar of a subject person, and in particular, to using a digitally rendered avatar of a subject person to interact with one or more users.

Technology and social media has greatly expanded the ability of people to engage and interact with other people from all over the world through text, audio, and video. However, this expanded audience also causes issues with being able to engage in one-on-one conversations or interactions with people who are particularly popular. For example, celebrities and other notable persons (such as politicians, athletes, etc.) may have many millions of followers. It is not practical or feasible in these cases for the celebrity or notable person to be able to interact with so many people on an individualized basis.

There is a need in the art for a system and method that provides increased access that allows for more individual interactions between people.

SUMMARY OF THE INVENTION

A system and method for providing an interactive digitally rendered avatar of a subject person is described herein.

In one aspect, a method of providing an interactive digital avatar of a subject person during a video presentation is provided. The method includes transmitting a video presentation featuring a subject person to a plurality of users via a first communication format. The method also includes receiving from at least one user of the plurality of users during the video presentation, a request to initiate an interactive session with an avatar of the subject person. In response to the request, the method includes generating a first avatar of the subject person and initiating a first interactive session between the first avatar and the at least one user. The method further includes engaging in the first interactive session between the first avatar of the subject person and the at least one user via a second communication format that is different than the first communication format.

In another aspect, a system for providing an interactive digital avatar of a subject person during a video presentation is provided. The system includes a communication interface allowing communication with one or more users of a plurality of users. The system also includes an artificial intelligence engine in communication with the communication interface. The artificial intelligence engine including at least one processor, a memory, and storage for computer-readable instructions that, when executed by the at least one processor, cause the at least one processor to transmit, via the communication interface, a video presentation featuring a subject person to the plurality of users via a first communication format. The instructions also cause the processor to receive from at least one user of the plurality of users during the video presentation, a request to initiate an interactive session with an avatar of the subject person. In response to the request, the instructions cause the processor to generate a first avatar of the subject person and initiate a first interactive session between the first avatar and the at least one user. The instructions also cause the processor to engage in the first interactive session between the first avatar of the

2

subject person and the at least one user via a second communication format that is different than the first communication format.

In another aspect, a method of providing an interactive digital avatar of a subject person is provided. The method includes transmitting a video featuring a subject person to a plurality of users via a first communication format. The method also includes receiving, from at least one user of the plurality of users, a request to initiate an interactive session with an avatar of the subject person. The method further includes engaging in the interactive session between the avatar of the subject person and the at least one user via a second communication format that is different than the first communication format.

In another aspect, a system for providing an interactive digital avatar of a subject person is provided. The system includes a communication interface allowing communication with one or more users of a plurality of users. The system also includes an artificial intelligence engine in communication with the communication interface, the artificial intelligence engine including at least one processor, a memory, and storage for computer-readable instructions that, when executed by the at least one processor, cause the at least one processor to: transmit, via the communication interface, a video featuring a subject person to the plurality of users via a first communication format; receive, from at least one user of the plurality of users, a request to initiate an interactive session with an avatar of the subject person; and engage in the interactive session between the avatar of the subject person and the at least one user via a second communication format that is different than the first communication format.

In still another aspect, a method of providing an interactive digital avatar of a subject person is provided. The method includes transmitting a video featuring at least one subject person to a plurality of users. The method also includes receiving, from a first user of the plurality of users, a request to initiate a first interactive session with a first avatar of a first subject person featured in the video. The method further includes engaging in the first interactive session between the first avatar of the first subject person and the first user. The method also includes receiving, from a second user of the plurality of users, a request to initiate a second interactive session with a second avatar of a second subject person featured in the video. The method includes engaging in the second interactive session between the second avatar of the second subject person and the second user. At least a portion of the first interactive session and the second interactive session occur concurrently.

Other systems, methods, features and advantages of the disclosure will be, or will become, apparent to one of ordinary skill in the art upon examination of the following figures and detailed description. It is intended that all such additional systems, methods, features and advantages be included within this description and this summary, be within the scope of the disclosure, and be protected by the following claims.

BRIEF DESCRIPTION OF THE DRAWINGS

The disclosure can be better understood with reference to the following drawings and description. The components in the figures are not necessarily to scale, emphasis instead being placed upon illustrating the principles of the disclosure. Moreover, in the figures, like reference numerals designate corresponding parts throughout the different views.

3

FIG. 1 is a block diagram of an example embodiment of a system for an interactive digitally rendered avatar of a subject person;

FIG. 2 is a detailed view of an example embodiment of an avatar database;

FIG. 3 is a detailed view of an example embodiment of a user database;

FIG. 4 is a representative view of an example embodiment of an avatar interface;

FIG. 5 is a representative view of an example embodiment of a user interface;

FIG. 6 is a flowchart of an example embodiment of a method for providing an interactive digitally rendered avatar of a subject person;

FIG. 7 is a representative view of an example embodiment of users engaging with an interactive digitally rendered avatar of a subject person;

FIG. 8 is a detailed view of an example embodiment of an interaction between a user and an interactive digitally rendered avatar of a subject person;

FIG. 9 is a representative view of an example embodiment of multiple users interacting with multiple interactive digitally rendered avatars of a subject person;

FIG. 10 is a representative view of an example embodiment of a user interacting with an interactive digitally rendered avatar of a subject person during a video;

FIG. 11 is a representative view of an example embodiment of users interacting with multiple interactive digitally rendered avatars of different subject people during a video;

FIG. 12 is a representative view of an alternate embodiment of a subject person providing a group presentation to a plurality of users;

FIG. 13 is a representative view of an alternate embodiment of providing an interactive digitally rendered avatar of a subject person to a user for a group presentation; and

FIG. 14 is a detailed view of an alternate embodiment of an interaction between a user and an interactive digitally rendered avatar of a subject person for a group presentation.

DETAILED DESCRIPTION

According to the techniques described herein, a system and method for an interactive digitally rendered avatar of a subject person is provided. The example embodiments allow one or more users to virtually interact with the digitally rendered avatar of the subject person in a way that mimics or emulates the speech, mannerisms, and inflections of the subject person.

The example embodiments described herein make use of methods and systems employing artificial intelligence (AI). As used herein, “artificial intelligence” may include any known methods or techniques in machine learning and related fields. As examples, artificial intelligence may include systems and methods used in natural language processing (NLP) and similar fields.

FIG. 1 is a block diagram of an example embodiment of a system 100 for providing an interactive digitally rendered avatar of a subject person. In some embodiments, components of system 100 may be implemented in hardware, software, and/or a combination of hardware and software to execute the functions and operations described herein to provide an interactive digitally rendered avatar. As will be described in more detail below, system 100 uses an artificial intelligence (AI) engine 102 to process and analyze a plurality of data associated with one or more subject persons and uses the data to render and generate an interactive avatar

4

of the subject person that is configured to mimic or emulate the speech, mannerisms, and inflections of the subject person.

In an example embodiment, AI engine 102 may include at least one computer system having a processor configured to execute programs to implement the techniques described herein. The term “computer system” refers to the computing resources of a single computer, the partial computing resources of a single computer, a plurality of computers communicating with one another, a network of remote servers, or other computing devices having at least one processor. In one embodiment, the computer system implementing AI engine 102 includes at least one processor, for example, a processor 104, configured to implement the functions of the interactive digitally rendered avatar system (e.g., system 100) described herein.

AI engine 102 may also include persistent storage 106 and a memory 108. In an example embodiment, storage 106 and memory 108 are computer readable storage media. For example, persistent storage 106 may be a magnetic hard disk drive, a solid state hard drive, a semiconductor storage device, read-only memory (ROM), erasable programmable read-only memory (EPROM), flash memory, or any other computer readable storage media that is capable of storing program instructions or digital information. In some embodiments, the media used by storage 106 may also be removable. For example, a removable hard drive may be used for storage 106. Other examples include optical and magnetic disks, thumb drives, and smart cards that are inserted into a drive for transfer onto another computer readable storage medium that is also part of storage 106.

Memory 108 may include random access memory (RAM) and/or cache memory. In general, memory 108 can include any suitable volatile or non-volatile computer readable storage media. Instructions for executing operations of AI engine 102 may be stored in storage 106 and/or memory 108 for execution by processor(s) 104.

One or more programs may be stored in storage 106 for execution by one or more of the respective computer processors 104 via one or more memories of memory 108. For example, the one or more programs may include software instructions that, when executed by the one or more processors 104, cause AI engine 102 to perform the operations of the interactive digitally rendered avatar system (e.g., system 100) described herein and shown in connection with the accompanying Figures.

Aspects of the example embodiments are described herein with reference to flowchart illustrations and/or block diagrams of methods, apparatus (systems), and computer program products according to the embodiments. It will be understood that each block of the flowchart illustrations and/or block diagrams, and combinations of blocks in the flowchart illustrations and/or block diagrams, can be implemented by computer readable program instructions.

In addition, AI engine 102 may include additional computing system components, such as a bus to provide communication between processor(s) 104, storage 106, and memory 108, as well as other components of system 100, such as a communication interface 110, a computer graphics interface (CGI) rendering module 112, an avatar interface 114, one or more databases (including an avatar database 116 and a user database 118), as well as various input/output (I/O) interface(s) that facilitate communication between the various components of system 100.

Communication interface 110 provides for communications with other data processing systems or devices over a communication network. In an example embodiment, com-

5

communication interface **110** may include one or more network interface cards. Communication interface **110** may provide communications through the use of either or both physical and wireless communications links. In an example embodiment, communication interface **110** may be configured to communicate using multiple types or formats of communication, including, but not limited to broadcast, multicast or other one-to-many communication sessions with a plurality of users, as well as one or more one-on-one communication sessions with individual users, such as two-way communication sessions that include transmitting and/or receiving video, audio, and/or text.

The communication network may be implemented by any number of any type of communications network (e.g., LAN, WAN, Internet, Intranet, VPN, etc.). The computer or other processing systems of the example embodiments may include any conventional or other communications devices to communicate over the network via any conventional or other protocols. The computer or other processing systems may utilize any type of connection (e.g., wired, wireless, etc.) for access to the network. Local communication media may be implemented by any suitable communication media (e.g., local area network (LAN), hardwire, wireless link, Intranet, etc.).

In an example embodiment, system **100** includes computer graphics interface (CGI) rendering module **112**. CGI rendering module **112** is configured to generate a digital representation of a subject person, including at least a face/head or a partial or full body of the subject person. In an example embodiment, the interactive digital avatar of the subject person rendered and generated by CGI rendering module **112** may be output for display through avatar interface **114** to interact with one or more users, as will be described in more detail below.

In the embodiment of FIG. 1, AI engine **102** may be in communication with one or more databases, avatar database **116** and/or user database **118**. Databases **116**, **118** could be co-located with AI engine **102** or could be remote databases that are accessible by AI engine **102** over a communication network. Databases **116**, **118** can include any kind of storage devices, including but not limited magnetic, optical, magneto-optical, and/or memory, including volatile memory and non-volatile memory.

In one embodiment, avatar database **116** may include one or more data collections containing information associated with each subject person and their associated avatar that may be digitally rendered using system **100**, as will be described in detail below in reference to FIG. 2. User database **118** may include data or information associated with one or more users of system **100**, as will be described in detail below in reference to FIG. 3.

In some embodiments, CGI rendering module **112** may receive information or data about the subject person from AI engine **102**, including information or data about the subject person stored in avatar database **116**, that allows CGI rendering module **112** to digitally render and generate an interactive avatar of the subject person that physically resembles the subject person and that is configured to mimic or emulate the speech, mannerisms, and inflections of the subject person.

Referring now to FIG. 2, a detailed view of an example embodiment of avatar database **116** is shown. In some embodiments, avatar database **116** may include one or more data collections comprising data or information associated with a subject person that allows AI engine **102** to generate an interactive digital avatar of the subject person. In an example embodiment, avatar database **116** may include a

6

plurality of data collections **200** for one or more avatars of a subject person or subject persons. As shown in FIG. 2, plurality of data collections **200** includes data collections associated with each of a first avatar **202**, a second avatar **204**, and a third avatar **206**. It should be understood that data collections for three avatars (**202**, **204**, **206**) are shown in FIG. 2 for purposes of illustration and avatar database **116** may include data collections for any number of avatars.

In some embodiments, a data collection and/or training process may be executed by AI engine **102** of system **100** to obtain, sort, analyze, and process the various data forming plurality of data collections **200** that is stored in avatar database **116** associated with each avatar. Additionally, AI engine **102** may also execute one or more training sessions using CGI rendering module **112** to generate a digital representation of the subject person for each subject person's avatar. These training sessions may be used to refine the interactive avatar of the subject person to accurately mimic or emulate the speech, mannerisms, and inflections of the subject person. In some embodiments, these training processes or sessions may be implemented using machine-learning techniques.

In some cases, plurality of data collections **200** may be associated with avatars of different subject persons. For example, a first data collection **208** for first avatar **202** may be associated with a first subject person, a second data collection **218** for second avatar **204** may be associated with a second subject person that is different from the first subject person, and a third data collection **220** for third avatar **206** may be associated with a third subject person that is different from both the second subject person and the first subject person.

Additionally or alternatively, plurality of data collections **200** may also be associated with avatars of the same subject person at different ages or age ranges. For example, first data collection **208** for first avatar **202** may be associated with a first subject person at a first age (or first age range) and second data collection **218** for second avatar **204** may be associated with the same first subject person at a second age (or second age range) that is different than the first age (e.g., at an older or younger age or age range).

By storing different data collections for avatars of the same subject person at different ages or ages ranges, the subject person may have an interactive digital avatar that mimics or emulates the speech, mannerisms, and inflections of the subject person at a first age and another interactive digital avatar that mimics or emulates the speech, mannerisms, and inflections of the subject person at a second age that is older or younger than the first age. With this arrangement, interactive digital avatars of the same subject person at different ages can accurately represent the physical appearance and speech, mannerisms, and inflections of the subject person at different time periods in the subject person's life.

In this embodiment, a representative data collection, for example, first data collection **208** for first avatar **202** is shown in detail. In an example embodiment, each data collection of plurality of data collections **200** may include various types and formats of data or information associated with a subject person. For example, as shown in FIG. 2, first data collection **208** may include audio data **210**, video data **212**, image data **214**, and/or text data **216** associated with a subject person.

Audio data **210** can include one or more voice files or recordings of the subject person speaking or reading so that AI engine **102** may use audio data **210** to accurately mimic the speech, voice inflections, and manner of speaking of the

subject person. For example, audio data **210** may include archived speeches by the subject person, recorded audio messages, songs, or readings by the subject person. Additionally, audio data **210** may also include audio files of the subject person obtained from video data **212**.

Video data **212** can include one or more video files or recordings of the subject person so that AI engine **102** may use video data **212** to accurately mimic facial expressions, hand movements, body posture, and other physical mannerisms of the subject person. For example, video data **212** may include short or long clips or movies of the subject person, including professional or home movies, as well as other video recordings from security cameras or motion capture devices.

Image data **214** can include one or more image files or photographs of the subject person so that AI engine **102** may use image data **214** to accurately render and generate the physical characteristics of at least the face/head or the partial or full body of the subject person from a variety of different angles and perspectives. AI engine **102** may use CGI rendering module **112** to generate a three-dimensional representation of the subject person from the plurality of two-dimensional representations of the subject person from image data **214**. Additionally, image data **214** may also include one or more frames of the subject person obtained from video data **212**.

Text data **216** can include one or more text files or data written, typed, or otherwise generated by the subject person. For example, text data **216** may include letters, emails, text messages, books, presentations, social media posts or comments, or any other format of text written or generated by the subject person.

In addition, audio data **210**, video data **212**, image data **214**, and/or text data **216** associated with the subject person stored in first data collection **208** may include dates, time stamps, or other identifiers of time that allow AI engine **102** to identify a time period or age range of the subject person when the associated data was generated. With this arrangement, first data collection **208** can represent the collected information or data associated with the subject person at a particular age or age range of their life so that the interactive digital avatar generated by AI engine **102** can accurately reflect the subject person at that particular age or age range.

As described herein, a subject person may include any person living or deceased. Examples of a subject person include, but are not limited to: celebrities, politicians or elected officials, athletes, scholars, teachers or professors, authors, trainers, experts in various fields, family members, historical figures, private individuals, or any other person. With this arrangement, any subject person may have a collection of data that allows AI engine **102** to generate an interactive digital avatar for that person.

In some embodiments, system **100** may certify or authenticate an avatar of a subject person to verify or confirm that the interactive digital avatar of the subject person is approved or authorized by the subject person. For example, an interactive digital avatar according to the example embodiment may include an indicia or certificate that asserts to users of system **100** that the avatar is verified as an official avatar approved by the subject person. With this arrangement, users can be assured of interacting with approved avatars of the subject person and imposter or fake avatars of the subject person may be avoided by users.

Referring now to FIG. **3**, a detailed view of an example embodiment of user database **118** is shown. In some embodiments, system **100** may store information or data associated with one or more users of system **100**. That is, users may be

any, person that interacts with one or more of the interactive digital avatars of a subject person generated by system **100**. In an example embodiment, user database **118** may include a plurality of user files **300** that contain data sets associated with each user of system **100**. In this embodiment, plurality of user files **300** includes a user file for a first **302**, a user file for a second user **304**, and a user file for a third user **306**. It should be understood that user files for three users (**302**, **304**, **306**) are shown in FIG. **3** for purposes of illustration and user database **118** may include user files for any number of users of system **100**.

In this embodiment, a representative user file, for example, a first data set **308** for first user **302** is shown in detail. In an example embodiment, each data set included in the user files of plurality of user files **300** may include various types of data or information associated with a user of system **100**. For example, as shown in FIG. **3**, first data set **308** may include personalization data **310**, account data **312**, and/or interaction data **314** associated with a user (e.g., first user **302**).

Personalization data **310** can include various personal data or information associated with first user **302** so that AI engine **102** may use personalization data **310** to customize or personalize the interaction between a digital avatar and first user **302**. For example, personalization data **310** may include the user's name, birthday, hair or eye color, names of family members, the user's preferences (e.g., nicknames, topics of conversation, greeting types, favorite subjects, etc.), and other information that can be used by AI engine **102** to personalize or customize interactions between the user and the digital avatar of the subject person.

Account data **312** can include account identifiers, such as user names and passwords or account numbers, billing and payment information for the user, including payment types (e.g., credit cards or cryptocurrency), billing addresses, subscription or account plan information, etc. For example, system **100** may bill or charge users on a per transaction basis (i.e., for each interactive avatar session), on a time basis (e.g., on a per minute or other time increment basis), and/or may include various tiers or membership plans that offer varying degrees or amounts of access to digital avatars. In some cases, different avatars may have different fees or rates. In other cases, system **100** may be free to users and may generate revenue through advertising or other types of sponsorships, including virtual endorsements by one or more of the digital avatars of system **100**.

Interaction data **314** can include various information and data associated with one or more interactive avatar sessions between the user and one or more avatars of a subject person or subject persons. For example, interaction data **314** may include log files or other captured transcripts of conversations between the user and the avatar, including dates, times, duration of the interaction, topics discussed, etc. The information or data included in interaction data **314** may be used by system **100** for billing purposes as well as to improve the personalization or customization of the interaction between the user and the digital avatar of the subject person. For example, information or data included in interaction data **314** obtained from an interactive session with a digital avatar (such as a user describing favorite colors or foods, or referring to family members by name or relationship) may be added to personalization data **310** in first data set **308** for first user **302** to be used by AI engine **102** in subsequent interactive sessions with a digital avatar to provide personalized or customized interactions with the user.

Plurality of user files **300** may include a similar user file for each user of the plurality of users of system **100** that is

stored in user database 118. For example, second user 304 may have a second data set 316 and third user 306 may have a third data set 318 that include data and information of a similar type and category as the data and information associated with first data set 308, but that is specific to the individual user. That is, each user (first user 302, second user 304, and third user 306) will have a unique data set in their user file stored in user database 118 that includes their own personalization data, account data, and interaction data. In this manner, user database 118 may be used by AI engine 102 of system 100 to ensure that each interactive session between a user and a digital avatar of a subject person is a uniquely personalized and/or customized experience, even when users are interacting with digital avatars of the same subject person. With this arrangement, because the interactive session uses the user's own data set from their user file, no two interactive sessions will be the same.

Referring now to FIG. 4, a representative view of an example embodiment of avatar interface 114 is shown. As described above, an interactive digital avatar of a subject person may be rendered and generated by CGI rendering module 112 and is output for display through avatar interface 114 to interact with one or more users. In this embodiment, avatar interface 114 includes a display area 400 in which an interactive digital avatar 402 is displayed. In an example embodiment, avatar interface 114 may be configured as an application or software program that executes instructions from AI engine 102 and CGI rendering module 112 to output interactive digital avatar 402 in display area 400 of avatar interface 114. In some embodiments, avatar interface 114 may be displayed on a display of a user interface of a user interacting with system 100, such as one or more of the user interfaces described below in reference to FIG. 5.

In some embodiments, avatar interface 114 may be embedded or integrated into an existing application or software program to allow the existing application or software program to provide the functionality of an interactive digital avatar in accordance with the techniques described herein. In these embodiments, components of system 100 may be provided as a module that interacts with and is included in the existing application or software program to provide interactive digital avatar capabilities to that existing application or software program. For example, an existing video calling, meeting, or presentation application or software program may incorporate the functionality of an interactive digital avatar using system 100.

In some embodiments, avatar interface 114 may provide one or more different types or forms of communication between interactive digital avatar 402 and the user interacting with interactive digital avatar 402 through avatar interface 114. In this embodiment, avatar interface 114 includes one or more of text 404, audio 406, and video 408 options for a user to interact with interactive digital avatar 402. For example, a user may choose to engage with interactive digital avatar 402 via text 404 by typing on a keyboard or touchscreen input, via audio 406 by speaking into a microphone or other audio sensor to capture user's spoken words or input, and/or via video 408 by using a video camera or other recording device to speak and interact with interactive digital avatar 402.

In this embodiment, interactive digital avatar 402 shown in display area 400 of avatar interface 114 is in the form of a head and/or face of a subject person. In other embodiments, interactive digital avatar 402 may take other forms, including at least a partial or full body avatar of the subject person. For example, in some embodiments, interactive

digital avatar 402 may include a representation of a subject person from the waist up and include hands and arms so that interactive digital avatar 402 may mimic or emulate hand movements or other body language of the subject person. In still other embodiments, interactive digital avatar 402 may include a full body representation of a subject person that mimics or emulates entire body movements or motions of the subject person, including, for example, walking gaits, dance moves, exercise routines, etc.

Referring now to FIG. 5, an example embodiment of a user interface 500 that allows a user to interact with system 100 is shown. In some embodiments, user interface 500 provides a mechanism that allows a user of system 100 to interact with or engage with an interactive digital avatar of a subject person through avatar interface 114. For example, avatar interface 114 may be an application or software program that runs or executes on user interface 500 and receives data or commands from AI engine 102 of system 100 to control the actions of the interactive digital avatar of the subject person through avatar interface 114.

In an example embodiment, user interface 500 may include at least one processor 502 and a display 504. Display 504 may be used to display the interactive digital avatar of the subject person through avatar interface 114. User interface 500 may also include one or more speakers 506 that are configured to output audio, including audio from the interactive digital avatar of the subject person through avatar interface 114. In some embodiments, user interface 500 may also include components that allows a user to send or transmit audio and/or video to system 100, such as, for example, a camera 508 configured to capture or record video and/or image information from the user and a microphone 510 configured to capture or record audio information from the user. In an example embodiment, system 100 may use inputs from a user captured by one or more of camera 508 and/or microphone 510 of user interface 500 to initiate an interactive session and/or during an interactive session with an avatar. For example, camera 508 and/or microphone 510 of user interface 500 may capture one or more of gestures, facial expressions, or body language of a user that may then be used by AI engine 102 of system 100 to start an interactive session or as an input used to determine potential responses by an interactive avatar to the user.

In some embodiments, user interface 500 may also include one or more other input devices 512 and/or one or more other output devices 514. In some embodiments, user interface 500 may also include an input and/or output to a voice assistant to allow a user to speak commands and instructions via user interface 500 to interact with system 100 and/or one or more interactive avatars generated by system 100. For example, a user may speak "initiate interactive session" to the voice assistant to request an interactive session with an interactive avatar of a subject person. With this arrangement, user interface 500 allows a user to engage in an interactive session with the interactive digital avatar of the subject person through avatar interface 114 in a manner that simulates a video and/or audio call with an actual person.

In different embodiments, user interface 500 may take any one or more of a variety of different forms or devices. For example, as shown in FIG. 5, user interface 500 may be embodied in a computer 520 on which the user may engage with interactive digital avatar of the subject person through avatar interface 114. User interface 500 may also be embodied in a mobile device 522, such as a smartphone or tablet computer, on which the user may engage with interactive digital avatar of the subject person through avatar interface

11

114, In still another embodiment, user interface 500 may be embodied in a virtual reality (VR) or augmented reality (AR) headset 524 on which the user may engage with interactive digital avatar of the subject person through avatar interface 114. It should be understood that the examples of user interface 500 shown in FIG. 5, including computer 520, mobile device 522, and/or VR/AR headset 524 are not limiting and other devices or forms of user interface 500 may be provided to interact with the interactive digital avatars of system 100.

Referring now to FIG. 6, a flowchart of an example embodiment of a method 600 for providing an interactive digitally rendered avatar of a subject person is illustrated. In some embodiments, method 600 may be implemented by at least one processor of system 100, for example, one or more of processors 104 of AI engine 102, described above, to provide the operations of interactive digitally rendered avatar described herein. Method 600 describes one example implementation of providing an interactive digitally rendered avatar of a subject person. It should be understood that other implementations may be provided, such as upon initiation or request by a user of system 100, as well as other methods.

In this embodiment, method 600 may begin at an operation 602. At operation 602, video featuring a subject person may be transmitted to a plurality of users via a first communication format. For example, at operation 602, a live or pre-recorded video of a subject person may be broadcast or streamed to a plurality of users of system 100. Next, method 600 includes an operation 604. At operation 604, a request to initiate an interactive session with an avatar of the subject person is received from at least one user of the plurality of users. For example, at operation 604, one of the users of the plurality of users receiving the video featuring the subject person at operation 602 may choose to engage in an interactive session with an interactive digital avatar of the subject person by sending a request to system 100.

Upon receiving the request from at least one user at operation 604, method 600 may proceed to an operation 606. At operation 606, method 600 includes engaging in the interactive session between the avatar of the subject person and the at least one user via a second communication format. For example, at operation 606, system 100 may initiate an interactive session between the user and the interactive digital avatar (e.g., interactive digital avatar 402) via a two-way communication format that allows the user and the interactive digital avatar to engage in a one-on-one conversation or interaction through avatar interface 114 on user interface 500, described above.

Additionally, method 600 includes an operation 608. At operation 608, the interactive session between the avatar of the subject person and the at least one user is personalized to the at least one user. For example, as described above in reference to FIG. 3, the interaction between the user and the interactive digital avatar (e.g., interactive digital avatar 402) may be personalized or customized using information (e.g., personalization data 310) from the data set in the user's user file stored in user database 118. With this arrangement, method 600 may provide a personalized and customized interactive session with a digital avatar of a subject person that is unique to the user. Method 600 may implemented any number of times for any number of users to generate separate interactive sessions for each user. Additionally, in some cases, method 600 may be implemented simultaneously or concurrently for multiple users of the plurality of users of system 100 so that each user may experience an individual, one-on-one interactive session with the digital

12

avatar of the subject person. Method 600 may also be implemented in a manner so that two or more interactive sessions between different users are overlapping or at least partially occurring at the same time.

Referring now to FIG. 7, an example embodiment of a scenario 700 in which a plurality of users are engaging with an interactive digitally rendered avatar of a subject person is shown. In this embodiment, a subject person 702, such as a celebrity or politician, is broadcasting or streaming a video to a plurality of users 704. In scenario 700, subject person 702 may be transmitting a pre-recorded video or may be live. For example, the video may be a panel discussion or talk, a movie or television program, a political rally, a sporting event, a concert, or any other live or recorded activity or event that is intended for an audience.

In an example embodiment, subject person 702 has an associated data collection stored in avatar database 116 of system 100 for an interactive digital avatar of subject person 702. For example, the data collection stored in avatar database 116 may include one or more of audio data, video data, image data, or text data associated with subject person 702 that allows AI engine 102 to generate an interactive digital avatar of subject person 702, as described above.

In an example embodiment, each subject person (e.g., subject person 702 in scenario 700) may have information or data gathered or collected for the data collection stored in avatar database 116 associated with the subject person's avatar in advance (i.e., before initiating an interactive session with the subject person's avatar). For example, as described above, a data collection and/or training process may be executed by AI engine 102 of system 100 to obtain, sort, analyze, and process the various data forming the data collection that is stored in avatar database 116 associated with the subject person's avatar. Additionally, AI engine 102 may also execute one or more training sessions using CGI rendering module 112 to generate a digital representation of the subject person for the subject person's avatar. These training sessions may be used to refine the interactive avatar of the subject person to accurately mimic or emulate the speech, mannerisms, and inflections of the subject person. In some embodiments, these training processes or sessions may be implemented using machine-learning techniques.

In this embodiment, subject person 702 in scenario 700 is shown broadcasting or streaming a video to plurality of users 704, including at least a first user 706, a second user 708, a third user 710, and a fourth user 712 (e.g., as part of operation 602 of method 600, described above). According to the example embodiments, plurality of users 704 may be located at different locations and may be using different devices (e.g., one or more types of user interfaces 500) to watch the video featuring subject person 702. In an example embodiment, when at least one user of plurality of users 704 would like to interact with a digital avatar of subject person 702 during the video, that user may send or transmit a request to system 100 to initiate an interactive session with an avatar of subject person 702 (e.g., as part of operation 604 of method 600, described above).

In this embodiment, first user 706 has made a request to start an interactive session with a digital avatar of subject person 702. In response, system 100 generates and renders a first interactive avatar 716 through a first avatar interface 714 to allow first user 706 to interact with first interactive avatar 716 of subject person 702. In contrast to the video from subject person 702 to plurality of users 704 (which may be a one-way communication, such as a broadcast or stream), the interactive session between first user 706 and first interactive avatar 716 is a two-way communication that

allows text, audio, and/or video to be transmitted and received in a bi-directional manner between first user 706 and first interactive avatar 716. For example, in one embodiment, the two-way communication between first user 706 and first interactive avatar 716 may be provided through first avatar interface 714 and at least one user interface 500 associated with first user 706.

Additionally, any of the other users of plurality of users 704 may also separately, simultaneously, or concurrently request to start their own interactive session with a digital avatar of subject person 702. In response to each such request, system 100 may generate and render additional instances of interactive digital avatars of subject person 702 to interact with each additional user making a request. For example, as shown in FIG. 7, third user 710 has also made a request to start an interactive session with a digital avatar of subject person 702. This request may be made at the same time as the request by first user 706 or may be made at a different time that is earlier or later than the request by first user 706. In response, system 100 generates and renders a second interactive avatar 720 through a second avatar interface 718 to allow third user 710 to interact with second interactive avatar 720 of subject person 702.

According to the example embodiments, each of first user 706 and third user 710 are engaging in an interactive session with a digital avatar of the same subject person (e.g., subject person 702), however, system 100 provides each user with their own instance of an interactive digital avatar (e.g., first interactive avatar 716 for first user 706 and second interactive avatar 720 for third user 710). With this arrangement, each user may have a personalized and customized interactive session with their specific instances of the digital avatar of subject person 702.

Referring now to FIG. 8, a detailed view of an example embodiment of an interaction between a user and an interactive digitally rendered avatar of a subject person is shown. In this embodiment, a representative interactive session 800 between first user 706 and first interactive avatar 716 of subject person 702 is shown. In an example embodiment, communication during interactive session 800 between first interactive avatar 716 and first user 706 may be made through first avatar interface 714 which may be provided on at least one type of user interface 500 associated with first user 706. In this embodiment, first avatar interface 714 includes one or more of text 802, audio 804, and video 806 options for first user 706 to interact with first interactive avatar 716.

For example, as described above, first user 706 may engage with first interactive avatar 716 via text 802 by typing on a keyboard or touchscreen input associated with user interface 500, via audio 804 by speaking into a microphone or other audio sensor associated with user interface 500 to capture spoken words or input by first user 706, and/or via video 806 by using a video camera or other recording device associated with user interface 500 to allow first user 706 to speak and interact with first interactive avatar 716 during interactive session 800.

In various embodiments, interactive session 800 between first user 706 and first interactive avatar 716 of subject person 702 may include any discussion of topics or interests that first user 706 would like to discuss. For example, in this embodiment of interactive session 800, first user 706 has asked first interactive avatar 716 "What is your favorite color?" to which first interactive avatar 716 has responded "My favorite color is purple." The information or data used to generate the responses by first interactive avatar 716 during interactive session may be obtained from the data

collection associated with the avatar stored in avatar database 116, described above. For example, the data collection may include at least one instance of text, audio, video, or image data where subject person 702 has stated that her favorite color is purple. Accordingly, system 100 may retrieve this information from avatar database 116 in order to allow first interactive avatar 716 of subject person 702 to answer the question from first user 706.

Interactive sessions may further include other representative topics. For example, in this embodiment of interactive session 800, subject person 702 is an actress and first user 706 has asked first interactive avatar 716 "Which movie was your favorite to work on?" to which first interactive avatar 716 has responded "All of them were fun, but my favorite was Avatar."

Additionally, as described above, in some embodiments, the interactive session between a user and the interactive digital avatar may be personalized or customized for the particular user, for example, using personalization data 310 stored in user database 118, described above. In this embodiment of interactive session 800, first user 706 has asked first interactive avatar 716 "Can you say 'Hi' to my mom, she's a big fan?" to which first interactive avatar 716 has responded "Hi 'User 1's Mom!' Thanks for your support".

In an example embodiment, system 100 may use personalization data 310 stored in user database 118 for first user 706 to replace "User 1's Mom" in the response provided by first interactive avatar 716 with the actual name of first user 706's mom. In this case, the response by first interactive avatar 716 would appear to first user 706 as "Hi, Nancy! Thanks for your support" (i.e., where "Nancy" is the name of first user 706's mom obtained by system 100 from personalization data 310). With this arrangement, first user 706 may experience a uniquely personalized and customized interactive session 800 with first interactive avatar 716 of subject person 702.

In some embodiments, system 100 may use personalization data 310 of first user 706 to suggest calling or sending a message to a third person associated with first user 706 (e.g., a family member, friend, colleague, coworker, etc.) using first interactive avatar 716. For example, a friend of first user 706 may be a big fan of subject person 702 (e.g., which may be known from personalization data 310 of first user 706 stored in user database 118) and would be excited to be contacted by first interactive avatar 716 of subject person 702 to wish them a Happy Birthday or to receive some other type of personalized message or call. In addition, such third party interactions may help add additional users to system 100.

In other embodiments, an interactive session between a user and an interactive digital avatar of a subject person may be limited to a predetermined number of topics or responses. For example, system 100 may prepare and save in avatar database 116 for each avatar, a menu or list of potential questions and their associated responses that may be used during an interactive session with a subject person's avatar. The predetermined topics or responses may be obtained by processing and analyzing the data collection associated with the subject person and/or may be prepared in advance by the subject person.

Referring now to FIG. 9, a representative view of an example embodiment of multiple users interacting with multiple interactive digitally rendered avatars of a subject person is shown. In this embodiment, a scenario 900 in which a plurality of users 902 are engaging with a plurality of interactive digitally rendered avatars 912 of a subject person 922 is shown. In this embodiment, each user of

plurality of users **902**, including a first user **904**, a second user **906**, a third user **908**, and a fourth user **910** is engaging in an interactive session with their own unique instance of an interactive digitally rendered avatar of subject person **922**. For example, as shown in FIG. 9, first user **904** is engaging in an interactive session with a first interactive avatar **914**, second user **906** is engaging in an interactive session with a second interactive avatar **916**, third user **908** is engaging in an interactive session with a third interactive avatar **918**, and fourth user **910** is engaging in an interactive session with a fourth interactive avatar **920**.

In this embodiment, each interactive avatar of plurality of interactive digitally rendered avatars **912** (e.g., first interactive avatar **914**, second interactive avatar **916**, third interactive avatar **918**, and fourth interactive avatar **920**) are representations of the same subject person, subject person **922** in this case. However, because each user of plurality of users **902** will ask different questions and otherwise engage with their own instance of the interactive digitally rendered avatar of subject person **922** in a different manner, each of the interactive sessions will be unique from each other.

In some embodiments, information associated with one or more interactive sessions between an interactive digital avatar of a subject person and one or more users (e.g., between plurality of interactive digitally rendered avatars **912** and plurality of users **902**) may be obtained for storage and/or monitoring by system **100**. For example, a summary of topics discussed, questions asked by users, answers given by interactive digital avatars, as well as information about session duration and/or connection quality may be provided back to system **100** for further analysis and storage, including, in some embodiments, stored as interaction data **314** in the associated user file of the user in user database **118**, as described above.

In some embodiments, the actual subject person (e.g., subject person **922**) may also be monitoring the one or more interactive sessions between the subject person's interactive digital avatar and one or more users (e.g., between plurality of interactive digitally rendered avatars **912** and plurality of users **902**). For example, this may allow the subject person to determine what topics of conversation or other interests are being discussed with the interactive avatars. In addition, in some embodiments, a user may ask a question to the interactive digital avatar of the subject person for which a response is not known or not available based on the information in the data collection in avatar database **116**. By monitoring the interactive sessions, the actual subject person may be alerted to such a question and may be able to provide a response.

In an example embodiment, system **100** allows a live subject person, such as subject person **922** in scenario **900**, to enter or cut into an existing interactive session between the subject person's interactive digital avatar and a user. The live subject person may then engage directly with the user in a live session between the live subject person and the user. For example, as shown in FIG. 9, during an interactive session between third user **908** and third interactive avatar **918**, live subject person **922** may enter or cut into the interactive session to establish a live session **924** directly between third user **908** and live subject person **922**. With this arrangement, if third user **908** has brought up a topic that is interesting to subject person **922** monitoring the interactive session between third user **908** and third interactive avatar **918**, subject person **922** may directly engage with third user **908** in live session **924** to further explore the topic or otherwise interact with third user **908** in real time.

Referring now to FIG. 10, a scenario **1000** of an example embodiment of a user **1014** interacting with an interactive digitally rendered avatar of a subject person featured in a video **1002** is shown. In this embodiment, user **1014** is watching video **1002** featuring a subject person. According to the techniques of the example embodiments described herein, at any time during scenario **1000**, user **1014** may request to start an interactive session with an interactive digitally rendered avatar of the subject person featured in video **1002**. For example, at a first time **1004** in video **1002** (e.g., at the 35 second mark of video **1002**), user **1014** may start an interactive session with an interactive avatar **1016** of the subject person shown in video **1002** (i.e., shown at first time **1004**, the 35 second mark, when user **1014** makes the request).

In this embodiment, user **1014** may continue to interact with interactive avatar **1016** during the interactive session for a period of time. For example, in scenario **1000** shown in FIG. 10, the interactive session between user **1014** and interactive avatar **1016** may last for a first period of time **1018** (e.g., 40 seconds). When the interactive session between user **1014** and interactive avatar **1016** ends after first period of time **1018**, user **1014** may rejoin or continue with video **1002** at the corresponding time, such as a third time **1008** (e.g., at the 1 minute, 15 second mark) that has progressed from when user **1014** started the interactive session with interactive avatar **1016** (i.e., 40 seconds after first time **1004**, the 35 second mark). The user **1014** may then continue with the remainder of video **1002**.

Alternatively, in some embodiments, when the interactive session between user **1014** and interactive avatar **1016** ends after first period of time **1018**, user **1014** may return to video **1002** at the next time after the interactive session began. For example, in this embodiment, user **1014** may return to video **1002** at a second time **1006** (e.g., the 36 second mark) that is directly after first time **1004** (e.g., the 35 second mark) when user **1014** made the request. With this arrangement, user **1014** may return back to the point in time of video **1002** from when the interactive session began.

It should be understood that user **1014** may engage in one or more subsequent interactive sessions with interactive avatar **1016** at other points of time in video **1002**, including, but not limited to second time **1006**, third time **1008**, a fourth time **1010**, and/or a fifth time **1012**. After each interactive session with interactive avatar **1016**, user **1014** may choose to return to the departure time in video **1002** or may rejoin video at a time that corresponds to the amount of real time that has progressed during each interactive session (e.g., first period of time **1018**, shown in FIG. 10).

Referring now to FIG. 11, a scenario **1100** of an example embodiment of users interacting with multiple interactive digitally rendered avatars of different subject people during a video **1102** is shown. In some embodiments, a video, such as video **1102**, may include multiple subject persons, each of which has an associated interactive digital avatar stored in avatar database **116**. As shown in scenario **1100** of FIG. 11, video **1102** may include at least two different subject persons, subject person A and subject person B. It should be understood, however, that a video may include any number of subject persons who may have an associated interactive digital avatar in accordance with the example embodiments described herein. For example, the video may be a movie with dozens or more actors and actresses, a sporting event with many different athletes, a panel discussion or presentation with many different speakers or presenters, or any other type of live or prerecorded video with multiple subject persons.

In an example embodiment, during video 1102, one or more users may request to engage in an interactive session with an interactive digital avatar of subject person A, subject person B, or both. For example, in this embodiment, video 1102 at various times will feature or depict one or both of subject person A and subject person B. As shown in scenario 1100, subject person A is shown at a first time 1104 of video 1102, as well as at a second time 1106, and a fifth time 1112. Subject person B, who is a different subject person than subject person A, is shown at a third time 1108 and a fourth time 1110 of video 1102. It should be understood that additional subject persons may also be shown at various times of video 1102.

According to the techniques of the example embodiments described herein, a user of system 100 may request to initiate an interactive session with an interactive digital avatar of the subject person shown at any corresponding time during video 1102. For example, in scenario 1100, a first user 1114 is shown engaging in an interactive session with a first interactive avatar 1116 of subject person A by making the request during first time 1104 of video 1002 (i.e., when subject person A is featured or depicted). Meanwhile, a second user 1118 in scenario 1100 is also shown engaging in an interactive session with a second interactive avatar 1120 of subject person B by making the request during third time 1108 of video 1002 (i.e., when subject person B is featured or depicted). With this arrangement, two different users (e.g., first user 1114 and second user 1118) watching the same video (e.g., video 1102) may interact with different interactive digital avatars (e.g., first interactive avatar 1116 and second interactive avatar 1120) for different subject persons (e.g., subject person A and subject person B).

In the example embodiments described above, the interactive digital avatar was of a subject person that is a celebrity or other notable person. In some embodiments, system 100 and the associated method described herein may also be used to provide an interactive digital avatar of other types of subject persons or for other scenarios. For example, the techniques described herein may be used for any type of group presentations or other situations, including, but not limited to lectures, work or business presentations, school lessons, political town hall meetings, exercise or training classes, or other scenarios involving one or more subject persons interacting with a plurality of people through video (including broadcast, live streaming, pre-recorded, etc.). In these embodiments, the techniques described herein may be used to provide an interactive digital avatar of the subject person or subject persons to allow the plurality of people to individually interact with the interactive digital avatar in their own personalized interactive sessions.

FIGS. 12 through 14 below illustrate an alternate embodiment of using system 100 to provide an interactive digital avatar of a subject person in a group presentation or similar situation. Referring now to FIG. 12, a scenario 1200 of a subject person 1202 providing a group presentation to a plurality of users 1204 is shown. In this embodiment, scenario 1200 may be a lecture or lesson given by subject person 1202, who may be a professor or teacher, to plurality of users 1204, who may be students or pupils of subject person 1202.

In an example embodiment of scenario 1200, the lecture or lesson by subject person 1202 may be provided via a first communication format, such as a live or pre-recorded video that is broadcast or streamed to each user of plurality of users 1204, including a first user 1206, a second user 1208, a third user 1210, a fourth user 1212, and/or a fifth user 1214. As described above, at any time during the lecture or

lesson by subject person 1202, one or more users of plurality of users 1204 may send or transmit a request to system 100 to initiate an interactive session with an avatar of subject person 1202 (e.g., as part of operation 604 of method 600, described above).

In some embodiments, system 100 may use input from user interface 500, such as one or more of gestures, facial expressions, or body language of a user captured by camera 508 and/or microphone 510 of user interface 500. For example, system 100 may use this input to analyze facial expressions of a user to determine that the user looks confused or distracted. In another example, system 100 may use the input to detect other types of gestures or actions, such as a user raising a hand or making other motions.

Referring now to FIG. 13, scenario 1200 is shown including an interactive digitally rendered avatar 1302 of subject person 1202 interacting with a first user 1206. In an example embodiment, subject person 1202 has an associated data collection stored in avatar database 116 of system 100 for an interactive digital avatar of subject person 1202. For example, the data collection stored in avatar database 116 may include one or more of audio data, video data, image data, or text data associated with subject person 1202 that allows AI engine 102 to generate an interactive digital avatar of subject person 1202, as described above. In scenario 1200, subject person 1202 is a teacher or professor and the data collection stored in avatar database 116 may include previous recorded lectures or lessons, as well as books, papers, presentations, etc. by subject person 1202.

According to the example embodiments, plurality of users 1204 may be located at different locations and may be using different devices (e.g., one or more types of user interfaces 500) to watch the video featuring subject person 1202. In an example embodiment, when at least one user of plurality of users 1204 would like to interact with a digital avatar of subject person 1202 during the video, that user may send or transmit a request to system 100 to initiate an interactive session with an avatar of subject person 1202 (e.g., as part of operation 604 of method 600, described above).

In this embodiment, first user 1206 has made a request to start an interactive session with a digital avatar of subject person 1202. In some embodiments, first user 1206 may initiate the interactive session through their user interface (e.g., one of user interfaces 500, described above) or system 100 may detect facial expressions or gestures made by first user 1206 that indicate that first user 1206 would like to initiate an interactive session. For example, in this embodiment, first user 1206 has raised his hand, which gesture or motion may be detected by system 100 using camera 508 of user interface 500, to request to start the interactive session with a digital avatar of subject person 1202.

In response, system 100 generates and renders interactive avatar 1302 through an avatar interface 1300 to allow first user 1206 to interact with interactive avatar 1302 of subject person 1202. In contrast to the video from subject person 1202 to plurality of users 1204 (which may be a one-way communication, such as a broadcast or stream), the interactive session between first user 1206 and interactive avatar 1302 is a two-way communication that allows text, audio, and/or video to be transmitted and received in a bi-directional manner between first user 1206 and interactive avatar 1302. For example, in one embodiment, the two-way communication between first user 1206 and interactive avatar 1302 may be provided through avatar interface 1300 and at least one user interface 500 associated with first user 1206 (e.g., a laptop computer in scenario 1200).

Additionally, any of the other users of plurality of users **1204** may also separately, simultaneously, or concurrently request to start their own interactive session with a digital avatar of subject person **1202**. In response to each such request, system **100** may generate and render additional instances of interactive digital avatars of subject person **1202** to interact with each additional user making a request, as described above in reference to the example embodiments.

Referring now to FIG. **14**, a detailed view of an example embodiment of an interaction between a user and an interactive digitally rendered avatar of a subject person is shown. In this embodiment, a representative interactive session **1400** between first user **1206** and interactive avatar **1302** of subject person **1202** is shown. In an example embodiment, communication during interactive session **1400** between interactive avatar **1302** and first user **1206** may be made through avatar interface **1300** which may be provided on at least one type of user interface **500** associated with first user **1206**. In this embodiment, avatar interface **1300** includes one or more of text **1402**, audio **1404**, and video **1406** options for first user **1206** to interact with interactive avatar **1302**.

For example, first user **1206** may engage with interactive avatar **1302** via text **1402** by typing on a keyboard or touchscreen input associated with user interface **500**, via audio **1404** by speaking into a microphone or other audio sensor associated with user interface **500** to capture spoken words or input by first user **1206**, and/or via video **1406** by using a video camera or other recording device associated with user interface **500** to allow first user **1206** to speak and interact with interactive avatar **1302** during interactive session **1400**.

In various embodiments, interactive session **1400** between first user **1206** and interactive avatar **1302** of subject person **1202** may include any discussion of topics or interests that first user **1206** would like to discuss. For example, in this embodiment of interactive session **1400**, first user **1206** may interact with interactive avatar **1302** of subject person **1202** to ask questions about the lecture or lesson provided by subject person **1202** on the video. As shown in FIG. **14**, first user **1206** has asked interactive avatar **1302** “Can you go over Problem 2?” to which interactive avatar **1302** (e.g., “Teacher Avatar” response in FIG. **14**) has responded “Sure, Problem 2 is about Exponentials. Have you studied Exponentials before?” That is, the potential responses or interactions by interactive avatar **1302** with first user **1206** may be shaped or based on an ascertained skill level of first user **1206**. In some embodiments, the skill level of first user **1206** may also be stored in the user file for first user **1206** stored in user database **118**. For example, the user file may include the student’s history, test results, grades, indicate previous classes attended, grades for other courses, etc. so that interactive avatar **1302** may determine the skill level of first user **1206** and base its responses on the skill level of first user **1206**.

In this embodiment, first user **1206** responds “No” and, based on this response, interactive avatar **1302** responds “Okay, then let’s start with the basics on page **76** of the textbook . . .” That is, in this example of interactive session **1400**, interactive avatar **1302** has determined the skill level of first user **1206** (e.g., based on the response to the question of whether first user **1206** had studied exponentials before) and has shaped or based its response (e.g., “then let’s start with the basics on page **76** of the textbook”) on the ascer-

tained skill level in order to personalize or customize interactive session **1400** to the particular situation of first user **1206**.

As described in previous embodiments, the information or data used to generate the responses by interactive avatar **1302** during interactive session **1400** may be obtained from the data collection associated with the avatar stored in avatar database **116**, described above. For example, the data collection may include at least one instance of text, audio, video, or image data where subject person **1202** has previously taught or given assistance with the subject of exponentials. Accordingly, system **100** may retrieve this information from avatar database **116** in order to allow interactive avatar **1302** of subject person **1202** to answer questions and provide help to first user **1206**.

Additionally, as described above, in some embodiments, the topics, responses, and other information provided during interactive session **1400** between first user **1206** and interactive avatar **1302** of subject person **1202** may be stored in the user file for first user **1206** (e.g., as interaction data **314**) and may also be provided back to subject person **1202**. For example, subject person **1202** may use the information about one or more interactions between plurality of users **1204** and interactive avatars to identify users that need further assistance with certain topics or to identify areas of the lecture or lesson that are difficult for many users of plurality of users **1204** to understand. That is, by monitoring or analyzing the interactions between plurality of users **1204** and interactive avatars, subject person **1202** may use this feedback to modify or improve her lecture or lesson.

While various embodiments of the disclosure have been described, the description is intended to be exemplary, rather than limiting and it will be apparent to those of ordinary skill in the art that many more embodiments and implementations are possible that are within the scope of the disclosure. Accordingly, the disclosure is not to be restricted except in light of the attached claims and their equivalents. Also, various modifications and changes may be made within the scope of the attached claims,

The invention claimed is:

1. A method of providing an interactive digital avatar of a subject person during a video presentation, the method comprising:

transmitting a video presentation featuring a subject person to a plurality of users via a first communication format;

receiving from at least one user of the plurality of users during the video presentation, a request to initiate an interactive session with an avatar of the subject person; wherein receiving the request during the video presentation comprises, prior to initiating the interactive session, recognizing a gesture made by the at least one user during the video presentation that indicates that the at least one user would like to initiate the interactive session;

in response to the request from the at least one user, (1) generating a first avatar of the subject person that physically resembles the subject person, and (2) initiating a first interactive session between the first avatar and the at least one user; and

engaging in the first interactive session between the first avatar of the subject person and the at least one user via a second communication format that is different than the first communication format.

2. The method according to claim **1**, wherein the subject person is a teacher and the plurality of users are students.

21

3. The method according to claim 2, wherein the first interactive session between the first avatar of the subject person and the at least one user is personalized to the at least one user using information associated with the at least one user stored in a user database.

4. The method according to claim 3, wherein the information associated with the at least one user includes one or more of a course, a grade, or a test result for the at least one user.

5. The method according to claim 1, further comprising: displaying the video presentation on a display of a user interface of the at least one user; and

upon initiation of the first interactive session, displaying the first avatar through an avatar interface on the display of the user interface of the at least one user.

6. The method according to claim 5, wherein the user interface includes a camera and a microphone; and wherein the request to initiate the interactive session is received from the camera or the microphone.

7. The method according to claim 1, further comprising: receiving, during the video presentation, a request to initiate an interactive session with an avatar of the subject person from a second user of the plurality of users, the second user being different than the at least one user engaging in the first interactive session with the first avatar of the subject person; and

in response to the request from the second user, (1) generating a second avatar of the subject person that physically resembles the subject person, and (2) initiating a second interactive session between the second avatar and the second user via the second communication format, wherein the second avatar is different from the first avatar and wherein the second avatar and the first avatar represent the same subject person.

8. The method according to claim 5, wherein the gesture is raising a hand by the at least one user captured by the camera of the user interface.

9. The method according to claim 5, wherein the gesture is based on a facial expression of the at least one user captured by the camera of the user interface.

10. The method according to claim 1, wherein information associated with the first interactive session between the first avatar and the at least one user is provided to the subject person upon completion of the first interactive session.

11. A system for providing an interactive digital avatar of a subject person during a video presentation, the system comprising:

a communication interface allowing communication with one or more users of a plurality of users;

an artificial intelligence engine in communication with the communication interface, the artificial intelligence engine including at least one processor, a memory, and storage for computer-readable instructions that, when executed by the at least one processor, cause the at least one processor to:

transmit, via the communication interface, a video presentation featuring at least a first subject person and a second subject person to the plurality of users via a first communication format;

receive from at least one user of the plurality of users at a first time during the video presentation, a request to initiate an interactive session with an avatar of the first subject person or the second subject person;

22

in response to the request, (1) generate a first avatar of one of the first subject person or the second subject person who is shown in the video presentation at the first time when the request is received from the at least one user, and (2) initiate a first interactive session between the first avatar and the at least one user, wherein the first avatar physically resembles the one of the first subject person or the second subject person; and

engage in the first interactive session between the first avatar of the one of the first subject person or the second subject person and the at least one user via a second communication format that is different than the first communication format.

12. The system according to claim 11, wherein each of the first subject person and the second subject person has an associated digital avatar stored in an avatar database in communication with the artificial intelligence engine.

13. The system according to claim 11, further comprising: a user database in communication with the artificial intelligence engine, wherein the user database includes a user file associated with the at least one user; and wherein the artificial intelligence engine uses the user file to personalize the first interactive session between the first avatar and the at least one user.

14. The system according to claim 11, wherein the instructions further cause the at least one processor to:

receive a request from at least one user of the plurality of users at a second time during the video presentation that is different from the first time to initiate an interactive session with an avatar of a different subject person than the one of the first subject person or the second subject person shown in the video presentation at the first time; and

in response to the request received at the second time, generate a second avatar of the different subject person.

15. The system according to claim 11, wherein the instructions further cause the at least one processor to:

display the video presentation on a display of a user interface of the at least one user; and upon initiation of the first interactive session, display the first avatar through an avatar interface on the display of the user interface of the at least one user.

16. The system according to claim 15, wherein the user interface includes a camera and a microphone; and wherein the request to initiate an interactive session is received from the camera or the microphone.

17. The system according to claim 16, wherein the request is initiated upon recognition of a gesture made by the at least one user.

18. The system according to claim 17, wherein the gesture is raising a hand by the at least one user captured by the camera of the user interface.

19. The system according to claim 17, wherein the gesture is based on a facial expression of the at least one user captured by the camera of the user interface.

20. The system according to claim 11, wherein information associated with the first interactive session between the first avatar and the at least one user is provided to the one of the first subject person or the second subject person upon completion of the first interactive session.

* * * * *