

US011112194B2

(12) **United States Patent**
Underwood et al.

(10) **Patent No.:** **US 11,112,194 B2**
(45) **Date of Patent:** **Sep. 7, 2021**

(54) **FIREARM LOCK**

USPC 42/49.01, 6, 50, 16, 18, 70.2, 70.02
See application file for complete search history.

(71) Applicants: **James Matthew Underwood**,
Kennesaw, GA (US); **Larry Cullen**
Underwood, Canton, GA (US)

(56) **References Cited**

(72) Inventors: **James Matthew Underwood**,
Kennesaw, GA (US); **Larry Cullen**
Underwood, Canton, GA (US)

U.S. PATENT DOCUMENTS

(*) Notice: Subject to any disclaimer, the term of this
patent is extended or adjusted under 35
U.S.C. 154(b) by 0 days.

4,326,825	A *	4/1982	Volkman	F16B 4/004
					411/361
4,422,679	A *	12/1983	Ruscitto	F16B 41/005
					292/307 R
4,429,479	A	2/1984	Johnson		
4,615,134	A	10/1986	Beretta		
5,120,168	A *	6/1992	Padula	F16B 31/021
					411/5
5,517,897	A	5/1996	Perrine		
5,519,954	A	5/1996	Garrett		
6,070,352	A	6/2000	Daigle		
8,756,845	B2	6/2014	Harris et al.		
8,943,866	B2 *	2/2015	Fernandez	F41A 17/38
					42/49.01
9,234,715	B2 *	1/2016	Cassady	F41A 9/61
10,094,632	B2	10/2018	Blakey et al.		
10,151,548	B2	12/2018	Cross		
10,359,244	B2	7/2019	Cross		
10,598,457	B2	3/2020	Maga		
2006/0123683	A1	6/2006	Garrett et al.		

(21) Appl. No.: **16/788,113**

(22) Filed: **Feb. 11, 2020**

(65) **Prior Publication Data**

US 2020/0292263 A1 Sep. 17, 2020

Related U.S. Application Data

(63) Continuation of application No. 15/845,209, filed on
Dec. 18, 2017, now Pat. No. 10,598,453.

(60) Provisional application No. 62/564,635, filed on Sep.
28, 2017, provisional application No. 62/467,389,
filed on Mar. 6, 2017, provisional application No.
62/435,535, filed on Dec. 16, 2016.

(51) **Int. Cl.**

F41A 17/38	(2006.01)
F41A 9/70	(2006.01)
F41A 9/67	(2006.01)
F41A 9/83	(2006.01)

(52) **U.S. Cl.**

CPC **F41A 9/70** (2013.01); **F41A 9/67**
(2013.01); **F41A 9/83** (2013.01); **F41A 17/38**
(2013.01)

(58) **Field of Classification Search**

CPC F41A 9/61; F41A 9/65; F41A 17/00; F41A
17/34; F41A 17/38

(Continued)

FOREIGN PATENT DOCUMENTS

GB 2210124 A * 6/1989 F16B 41/005

Primary Examiner — Jonathan C Weber

(57) **ABSTRACT**

A firearm loader may be used to transfer at least one
cartridge to a firearm. The loader includes a main body
comprising a proximal end and a distal end and a follower
disposed inside the main body. The loader may include an
engaged configuration wherein the loader is at least partially
inserted into a firearm. The proximal end may include an
opening. In the engaged configuration, the opening approxi-
mately faces a magazine of the firearm.

21 Claims, 25 Drawing Sheets

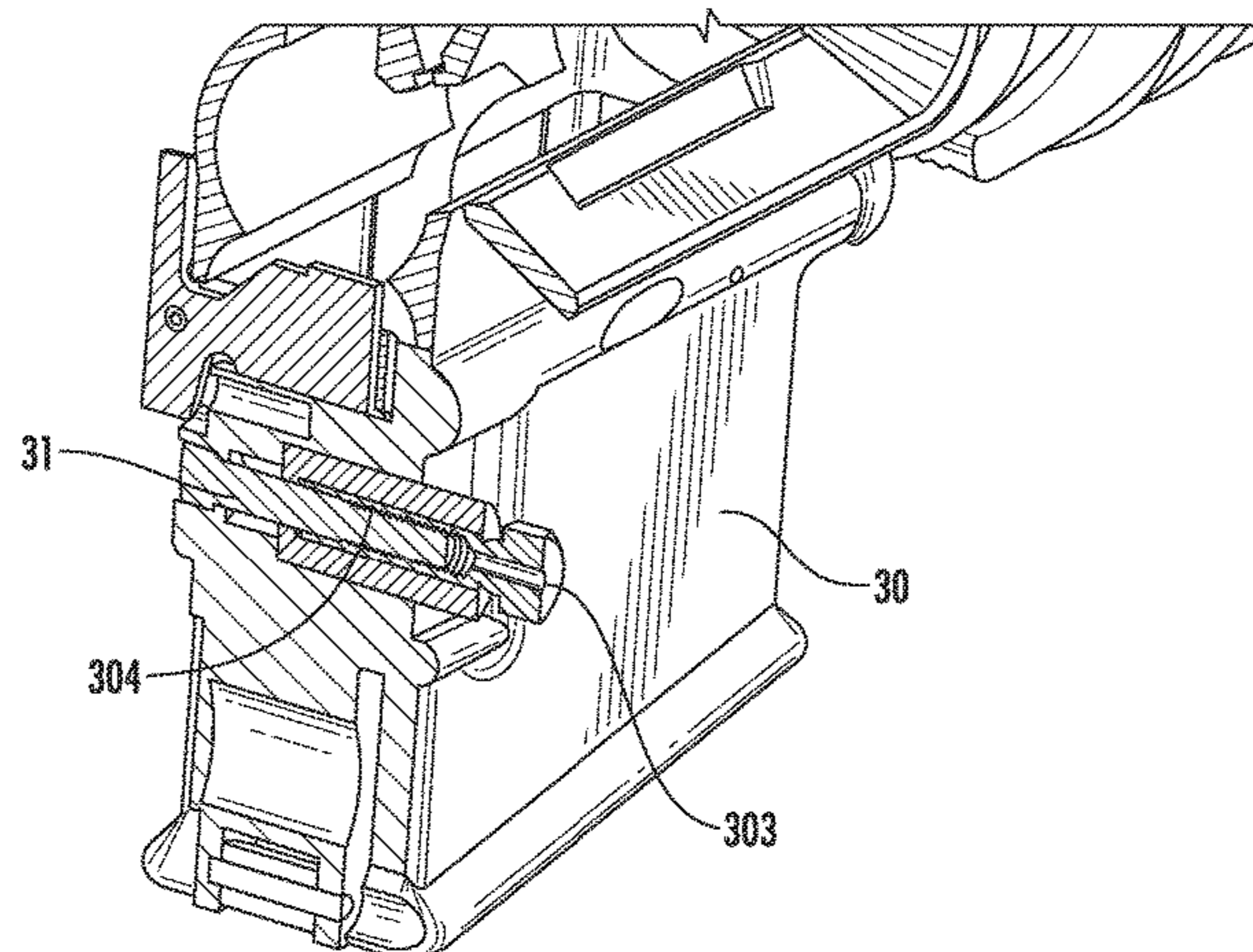
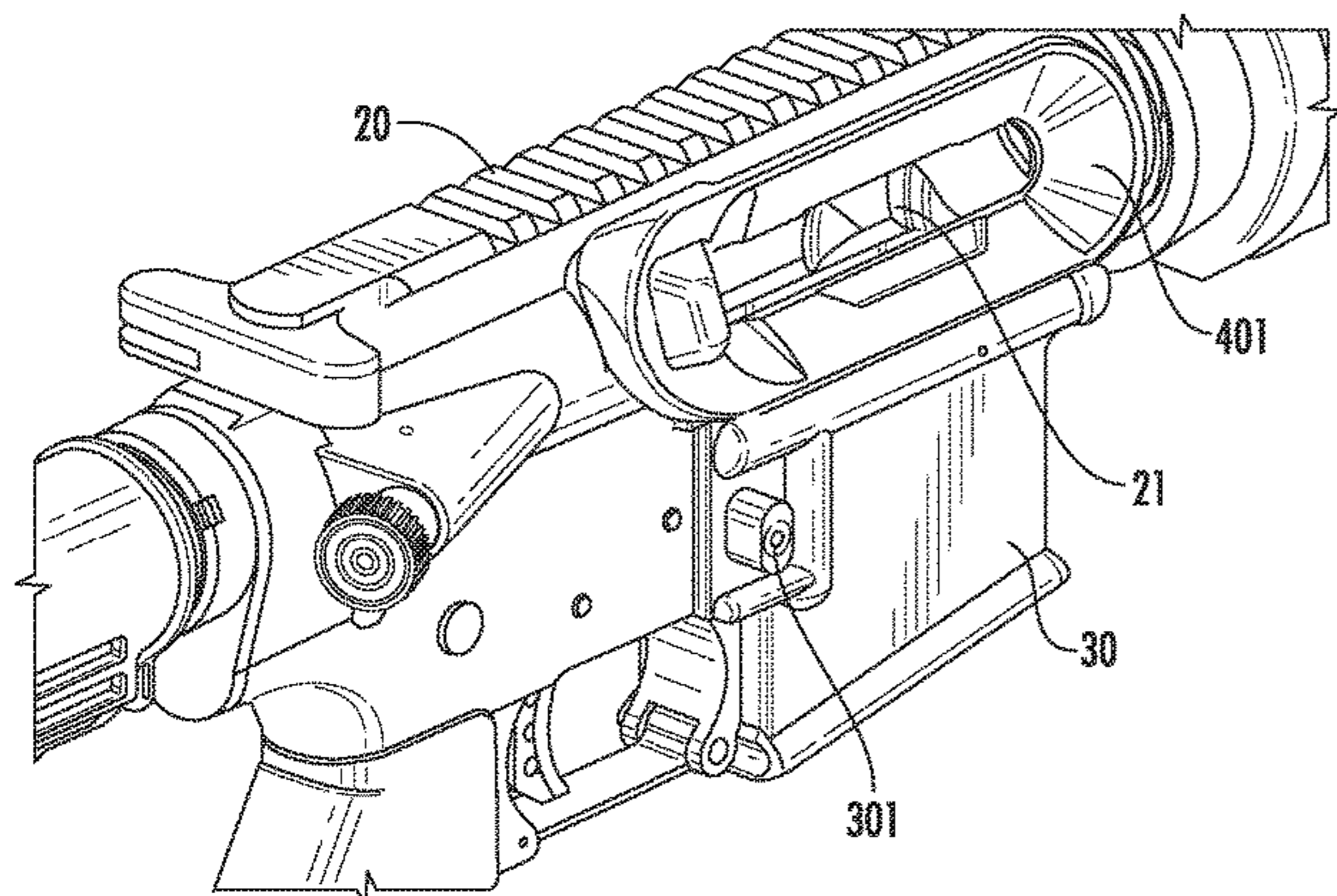

(56)

References Cited

U.S. PATENT DOCUMENTS

2013/0227869 A1* 9/2013 Thordsen F41C 27/00
42/6
2014/0165439 A1* 6/2014 Fernandez F41A 17/42
42/6
2015/0052793 A1* 2/2015 Cassady F41A 9/61
42/8
2018/0238359 A1 8/2018 Cross
2019/0219348 A1 7/2019 Maga
2019/0219352 A1 7/2019 Maga
2020/0025485 A1 1/2020 Blakey et al.

* cited by examiner

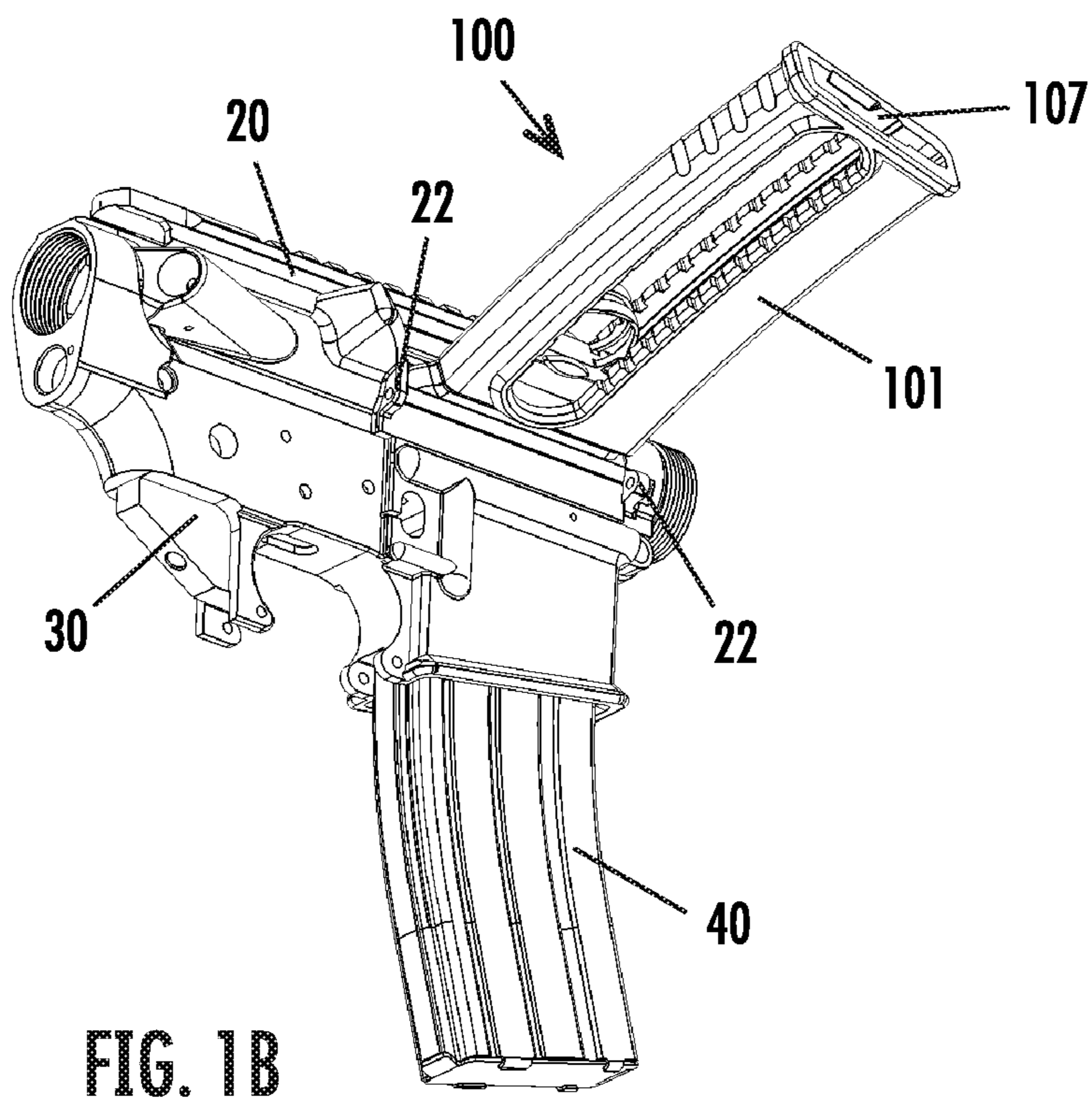
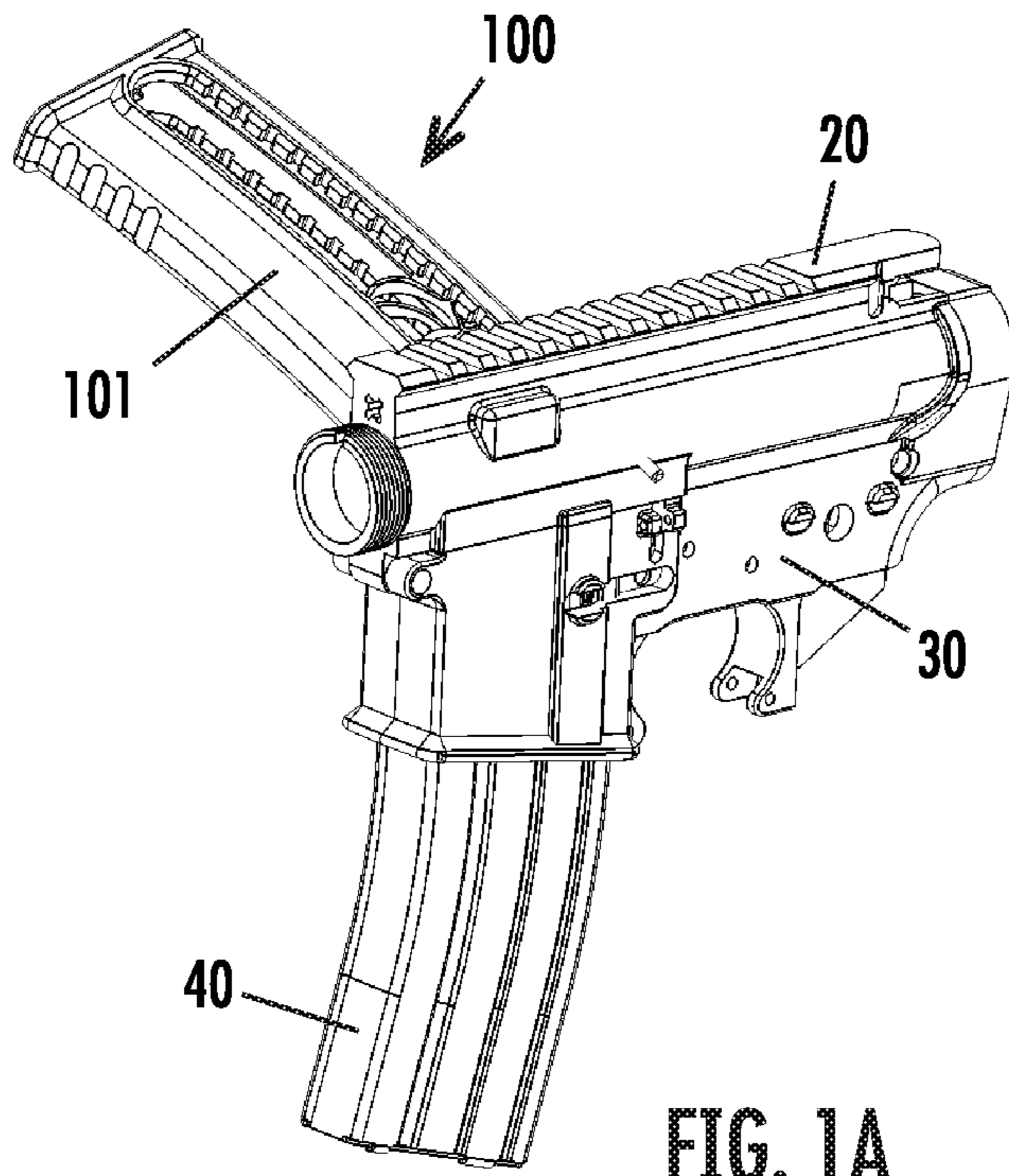

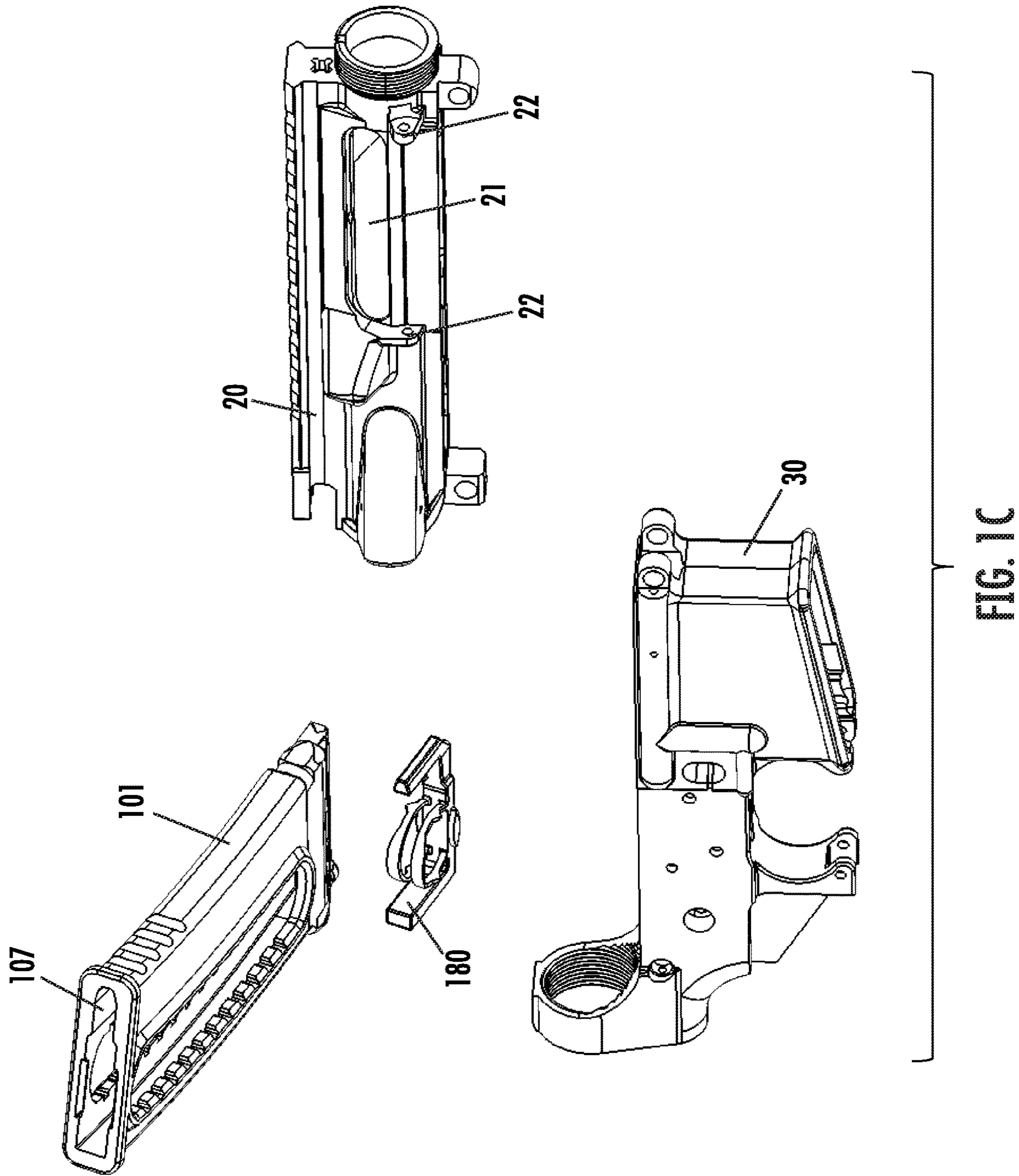

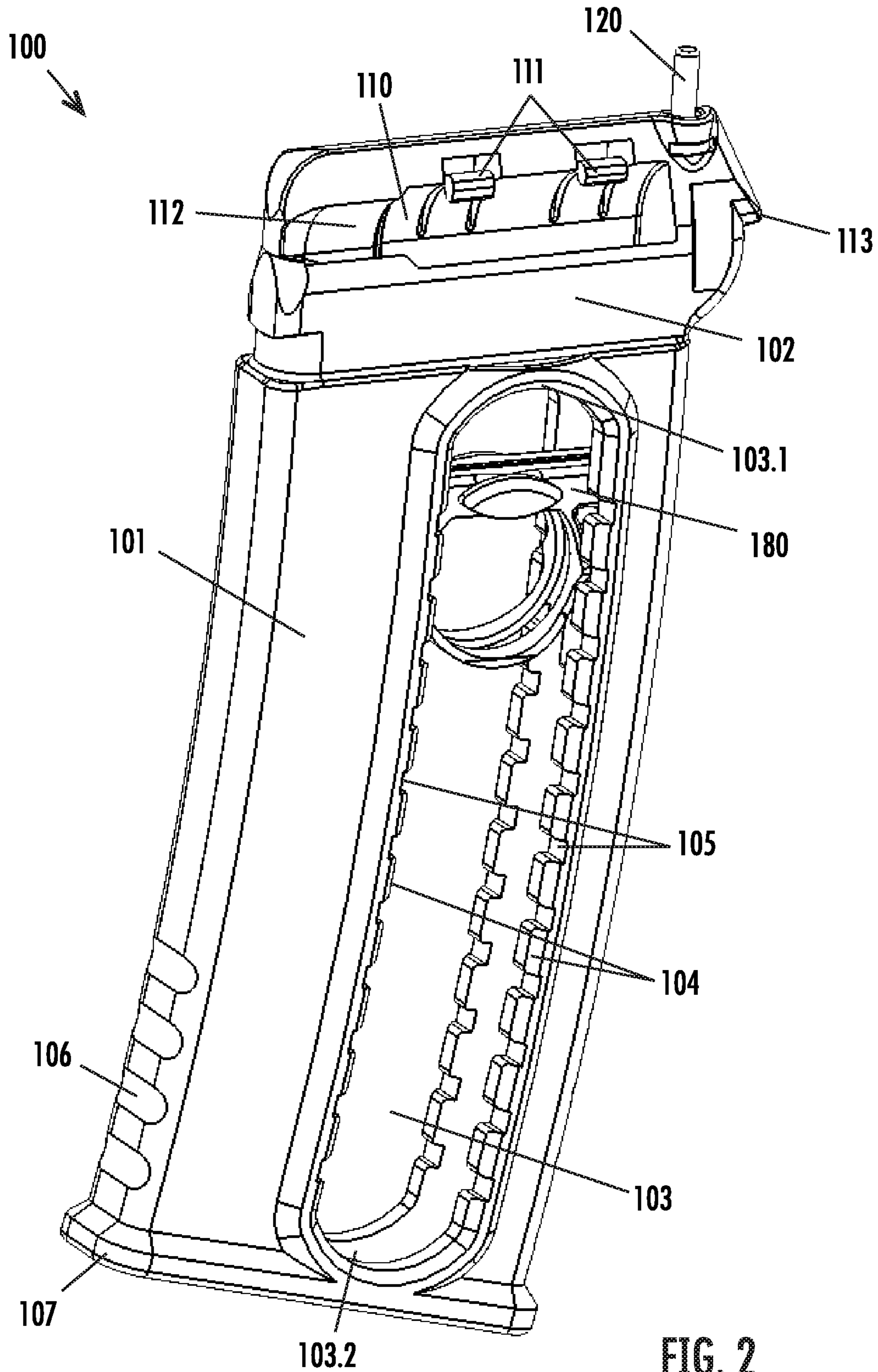

FIG. 2

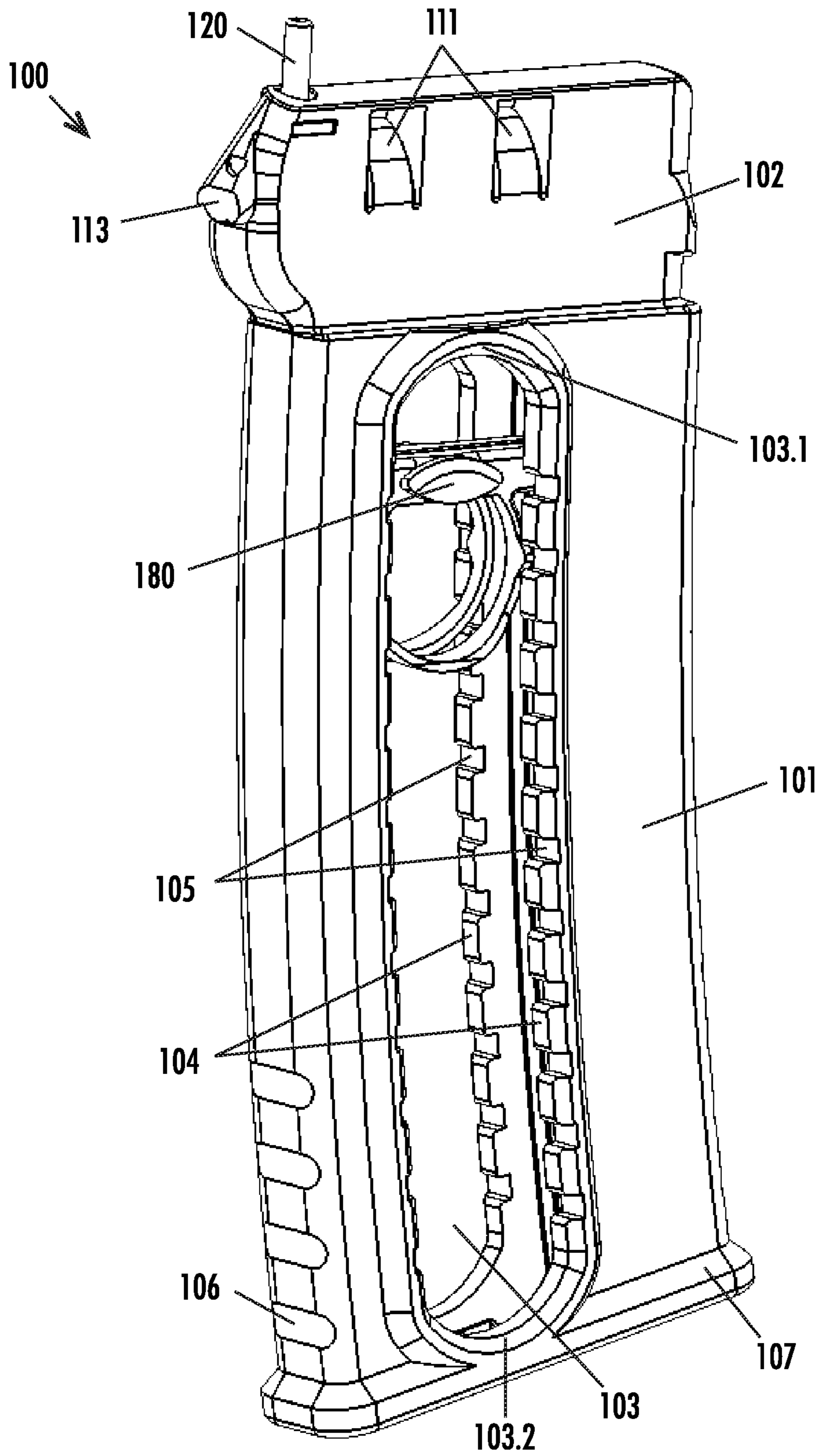

FIG. 3

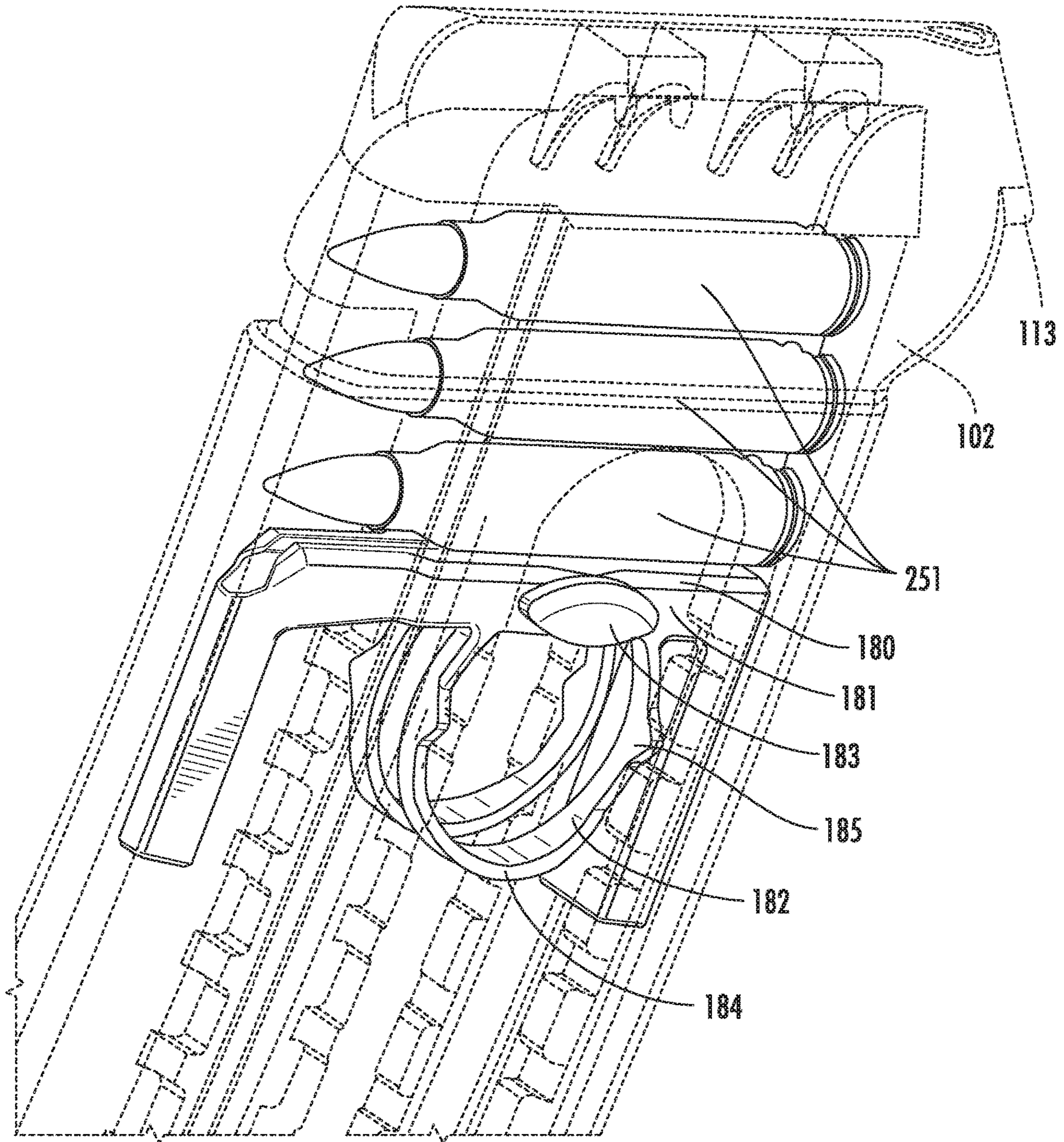
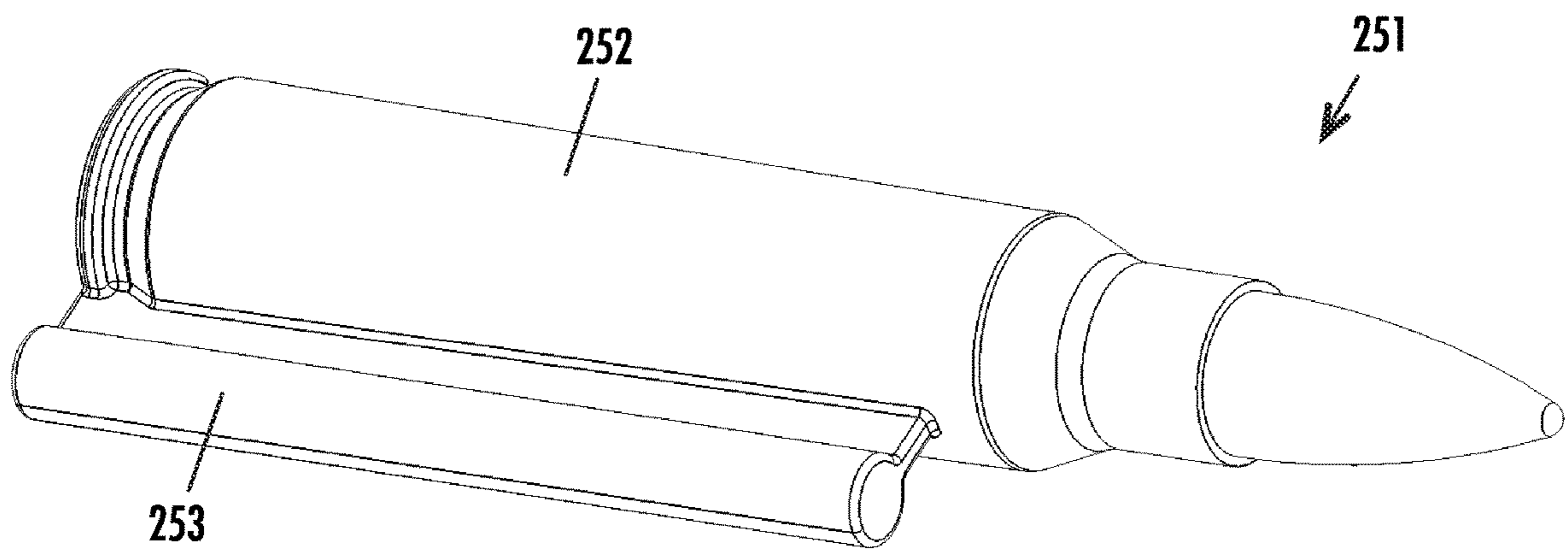
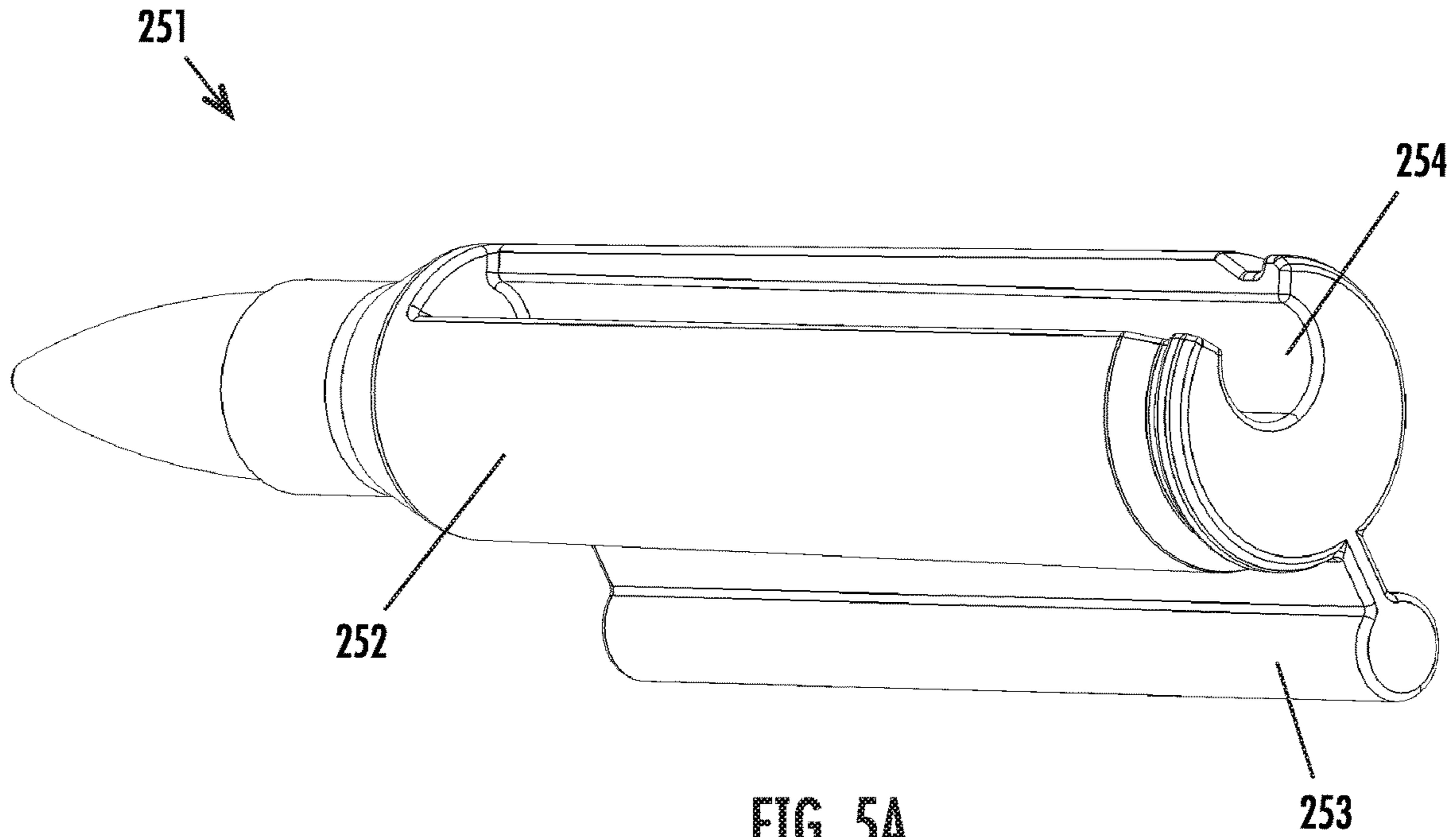

FIG. 4



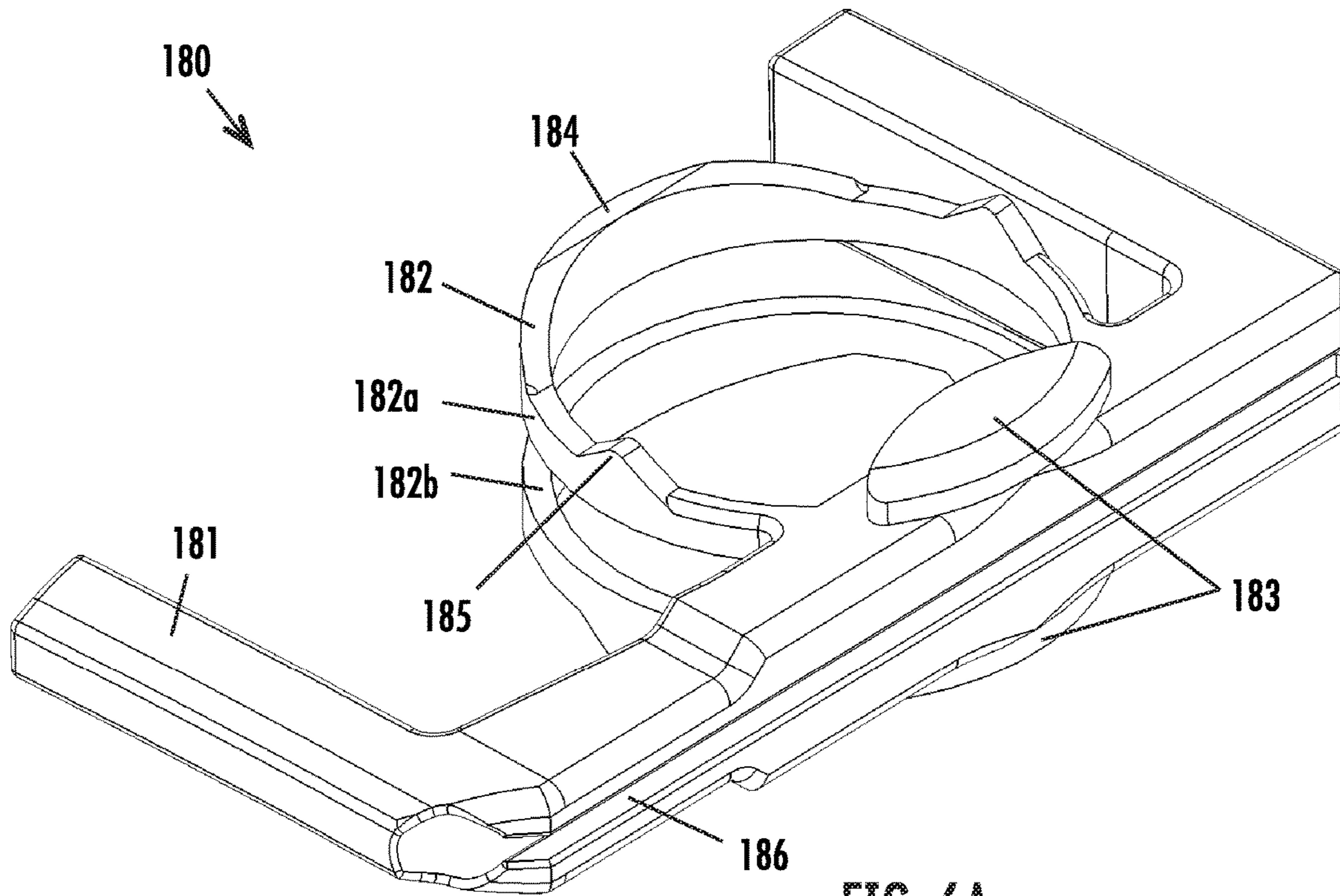

FIG. 6A

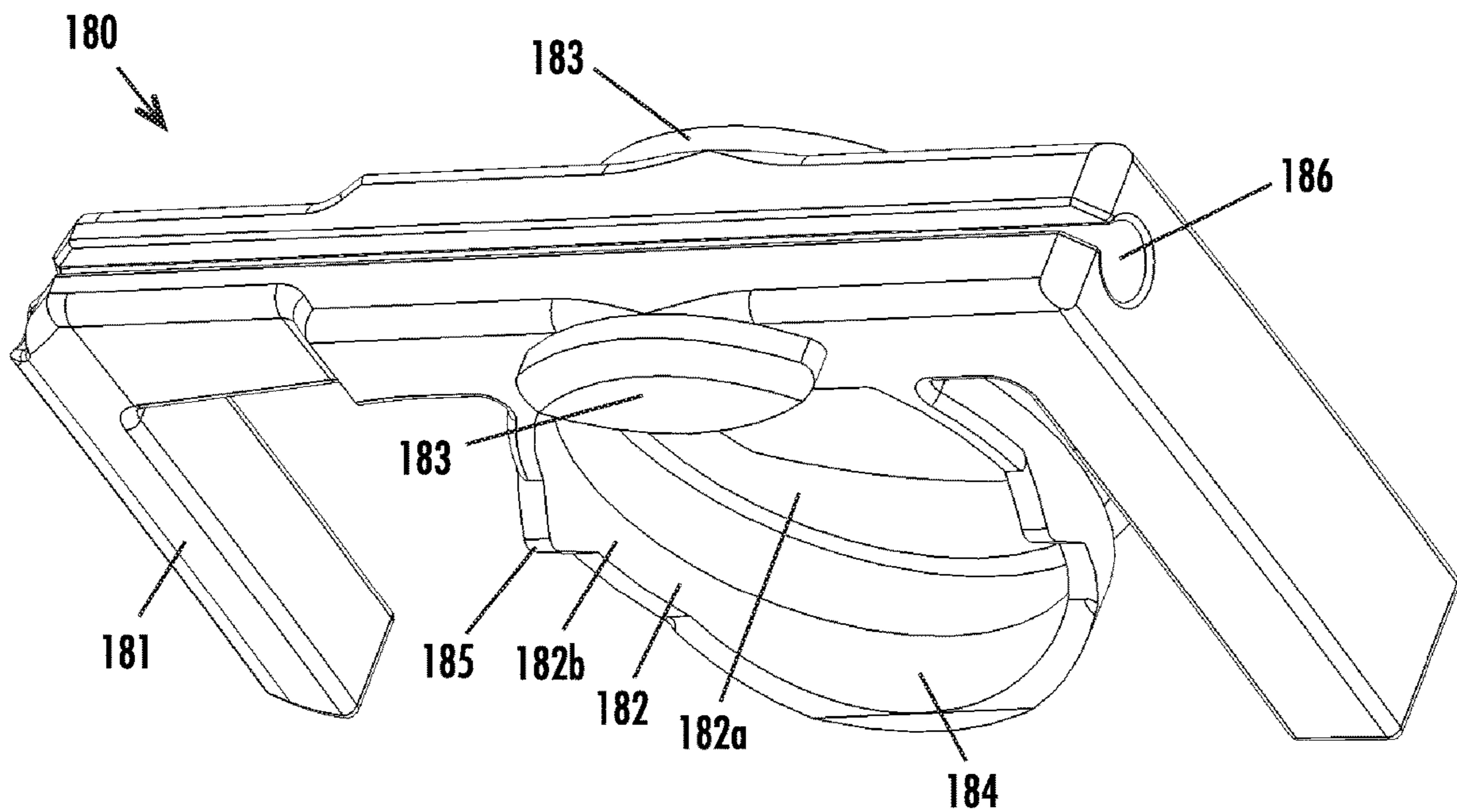

FIG. 6B

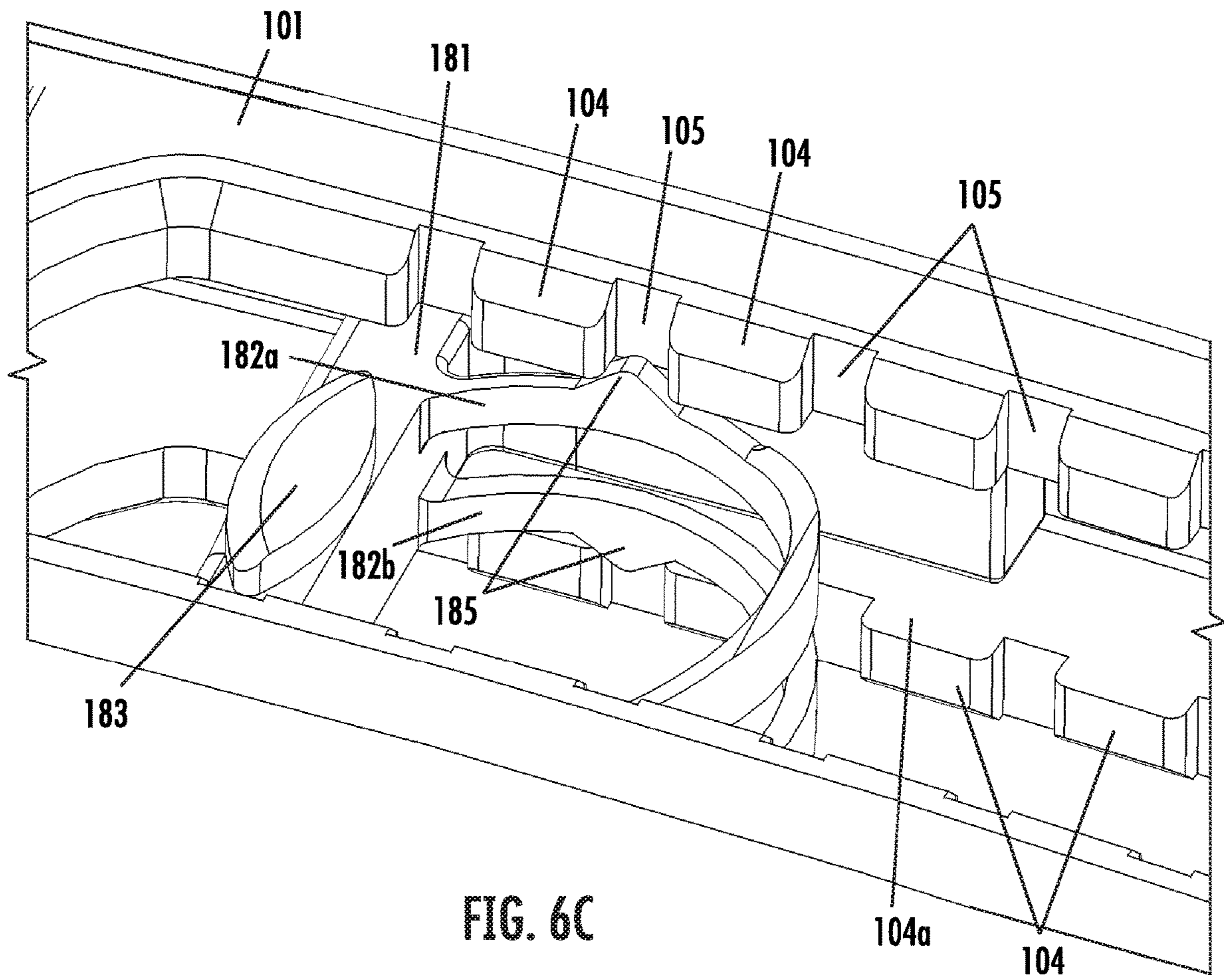
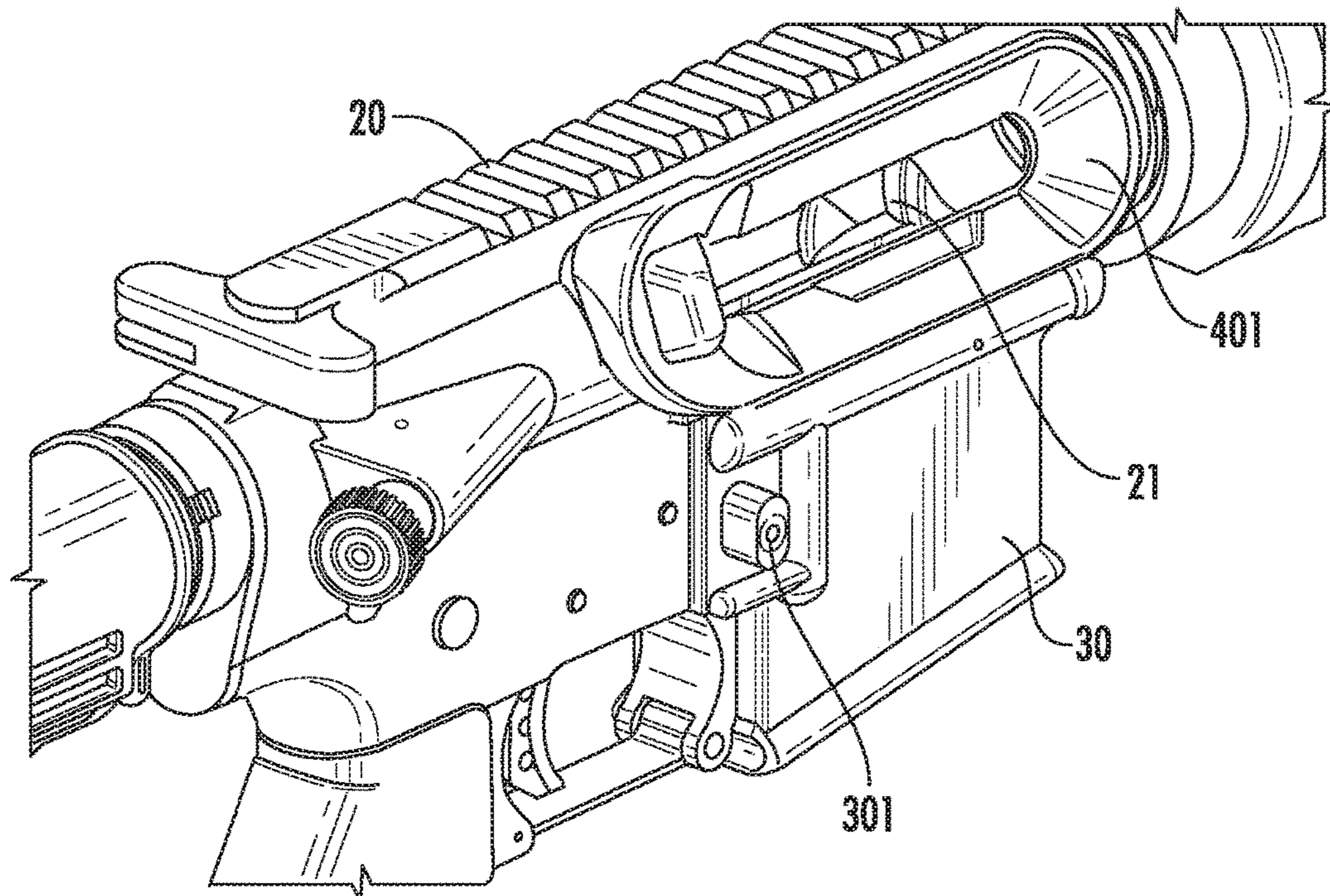
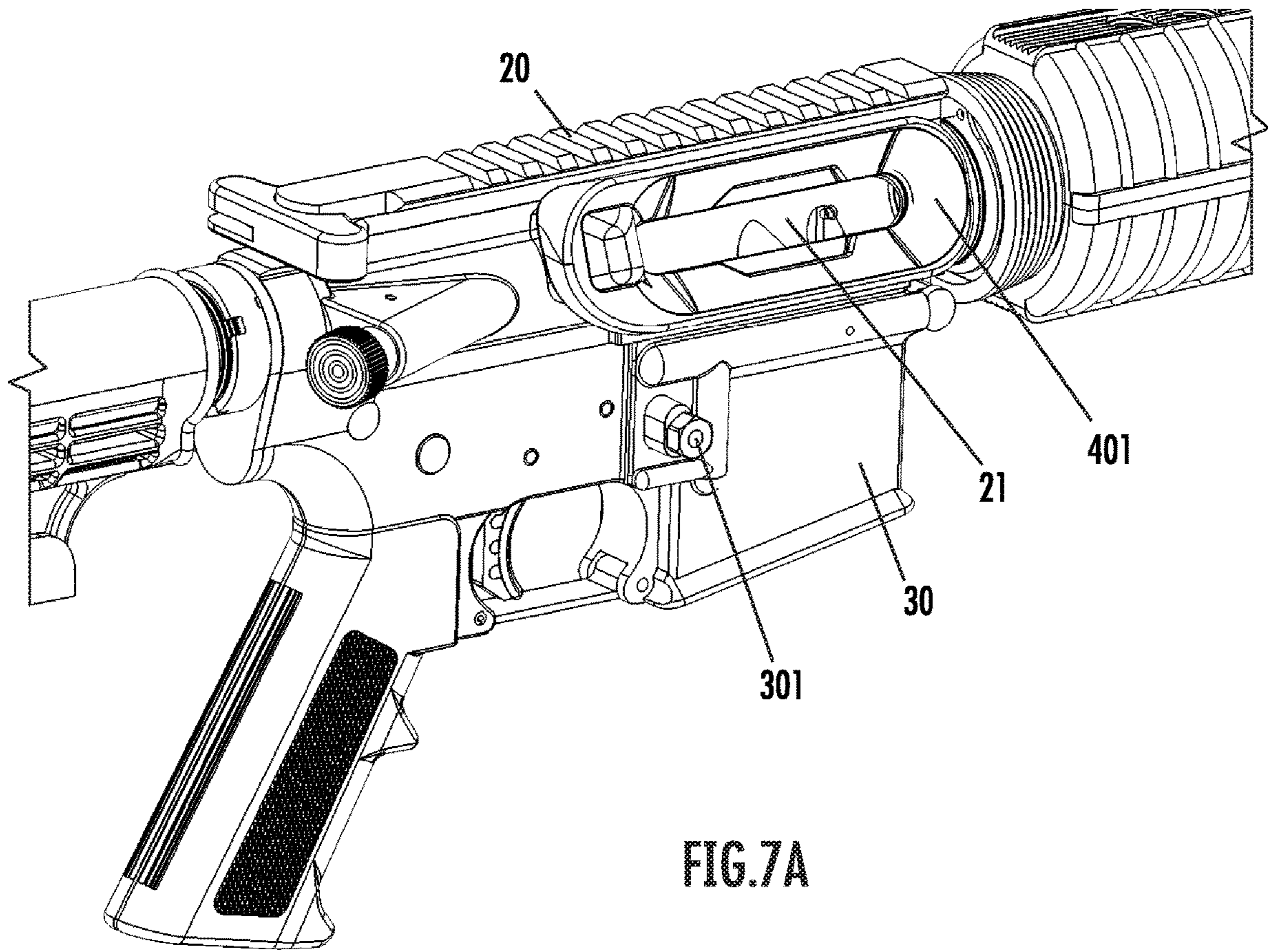

FIG. 6C



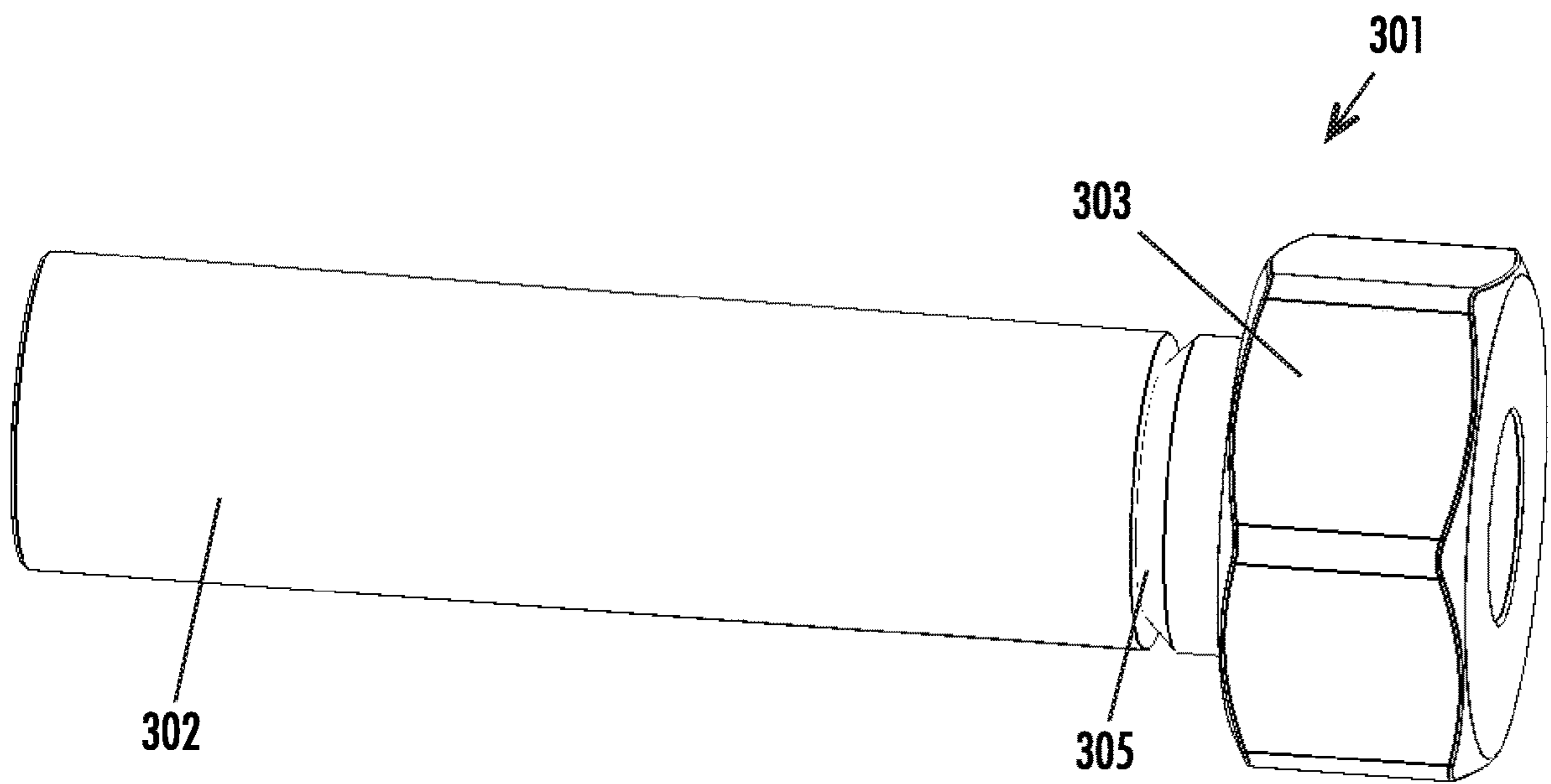

FIG. 8A

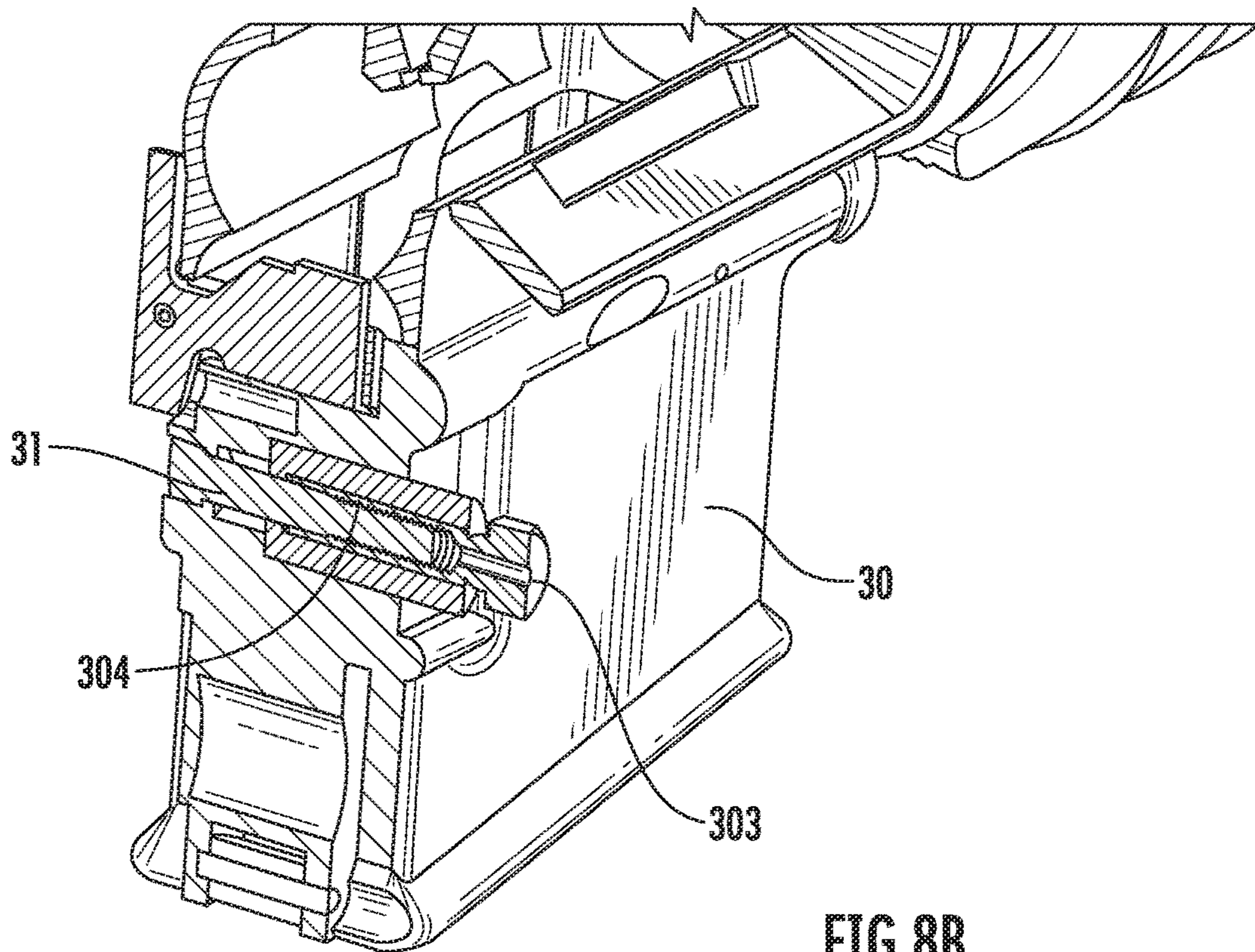

FIG. 8B

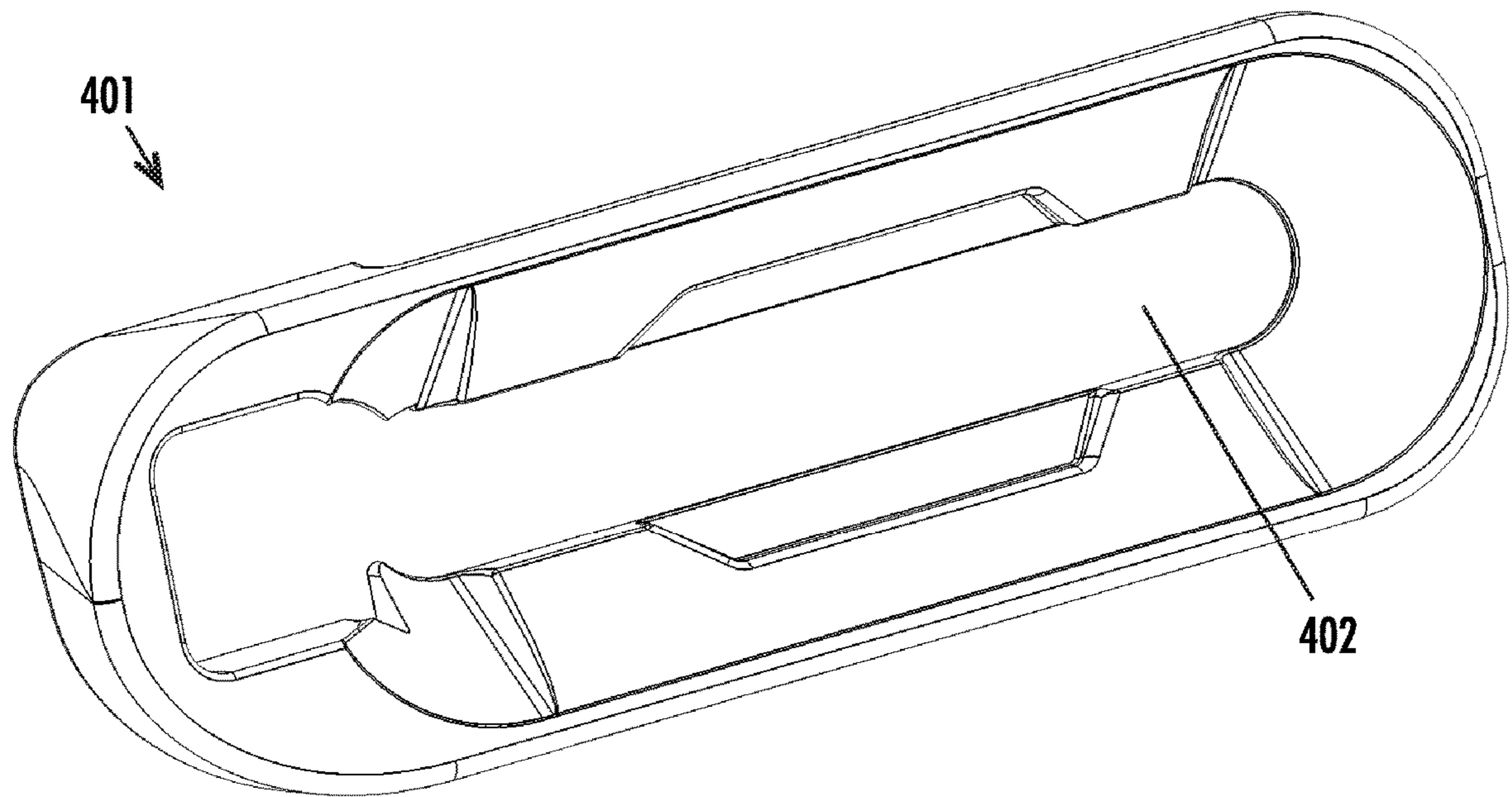

FIG. 9A

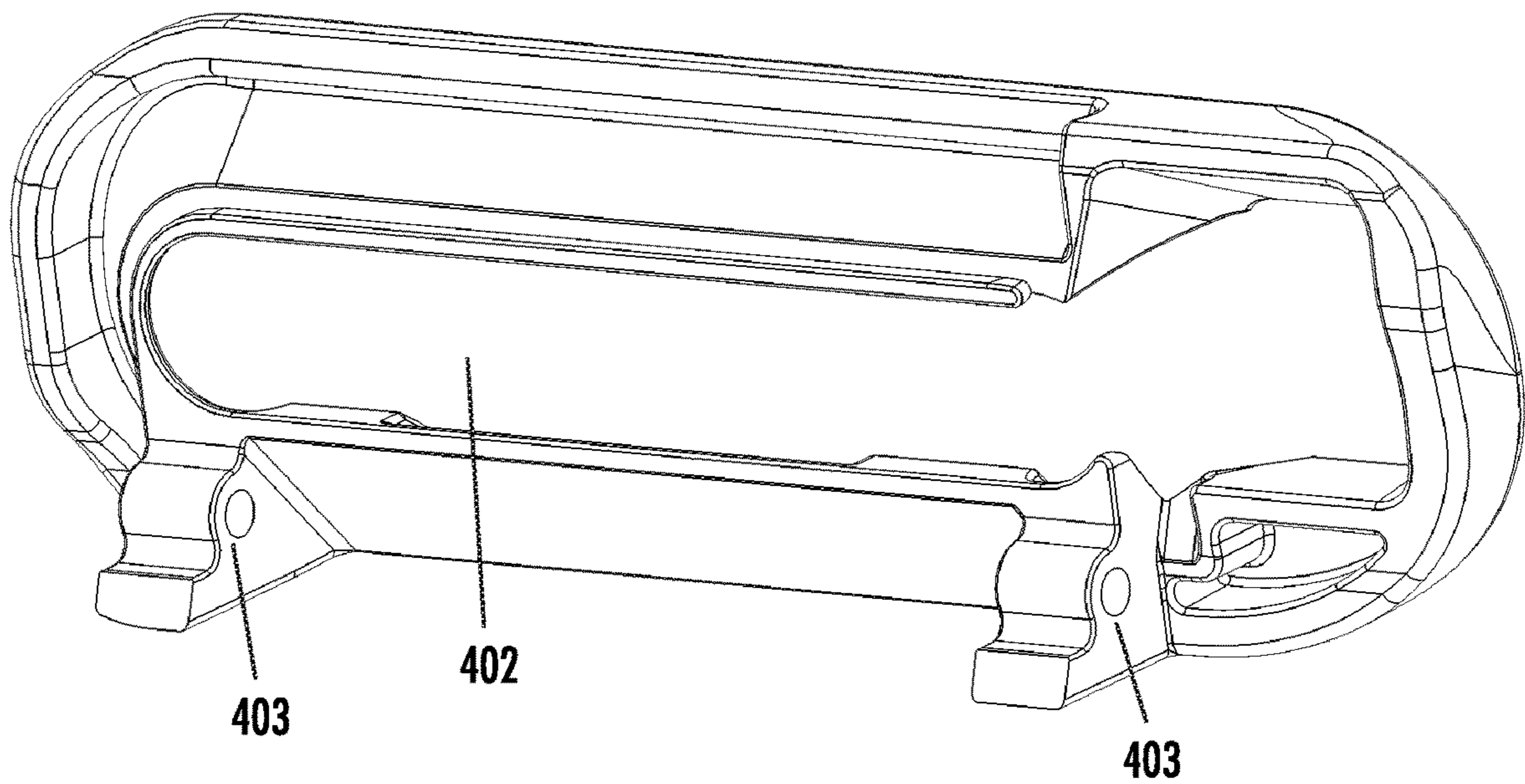

FIG. 9B

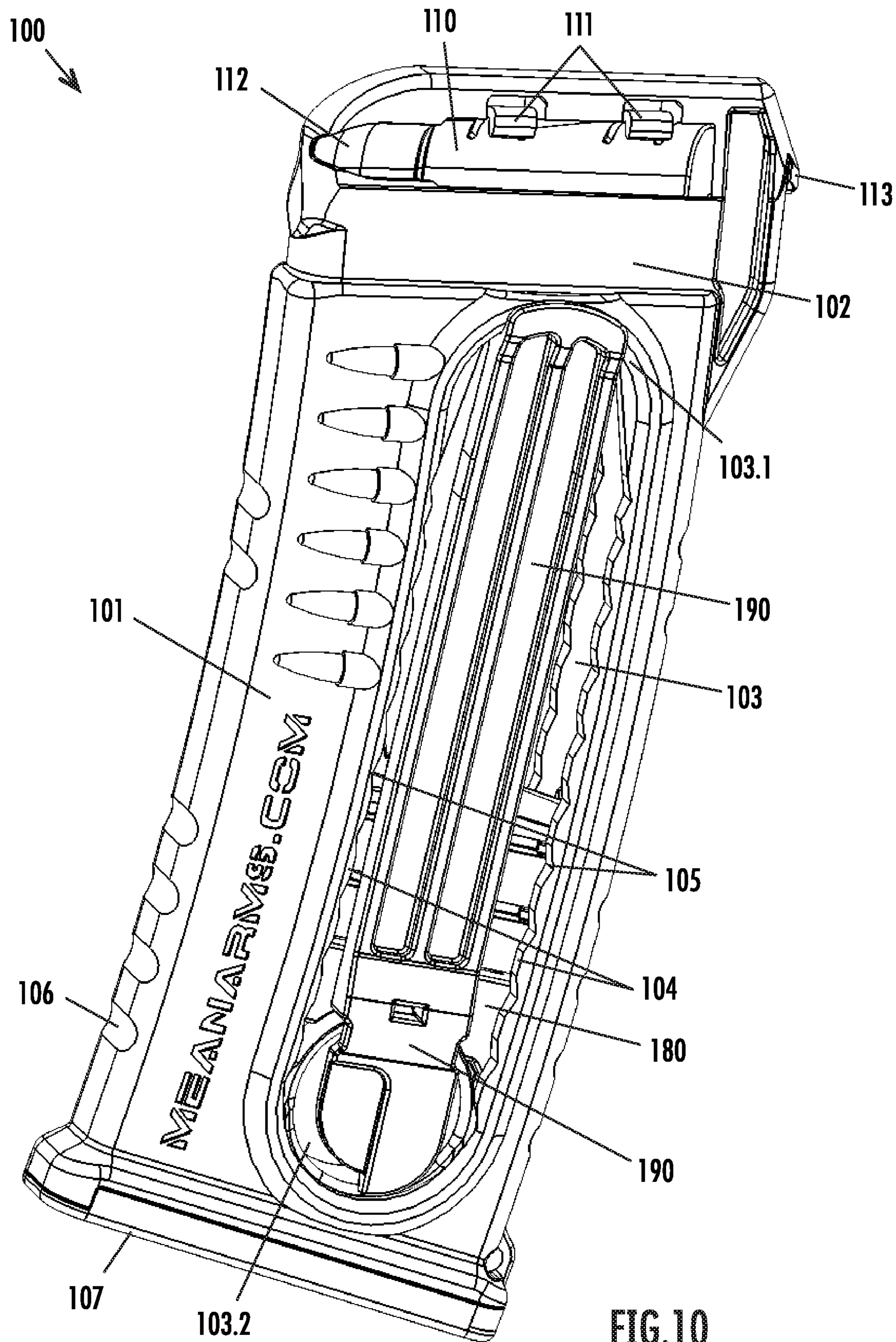

FIG. 10

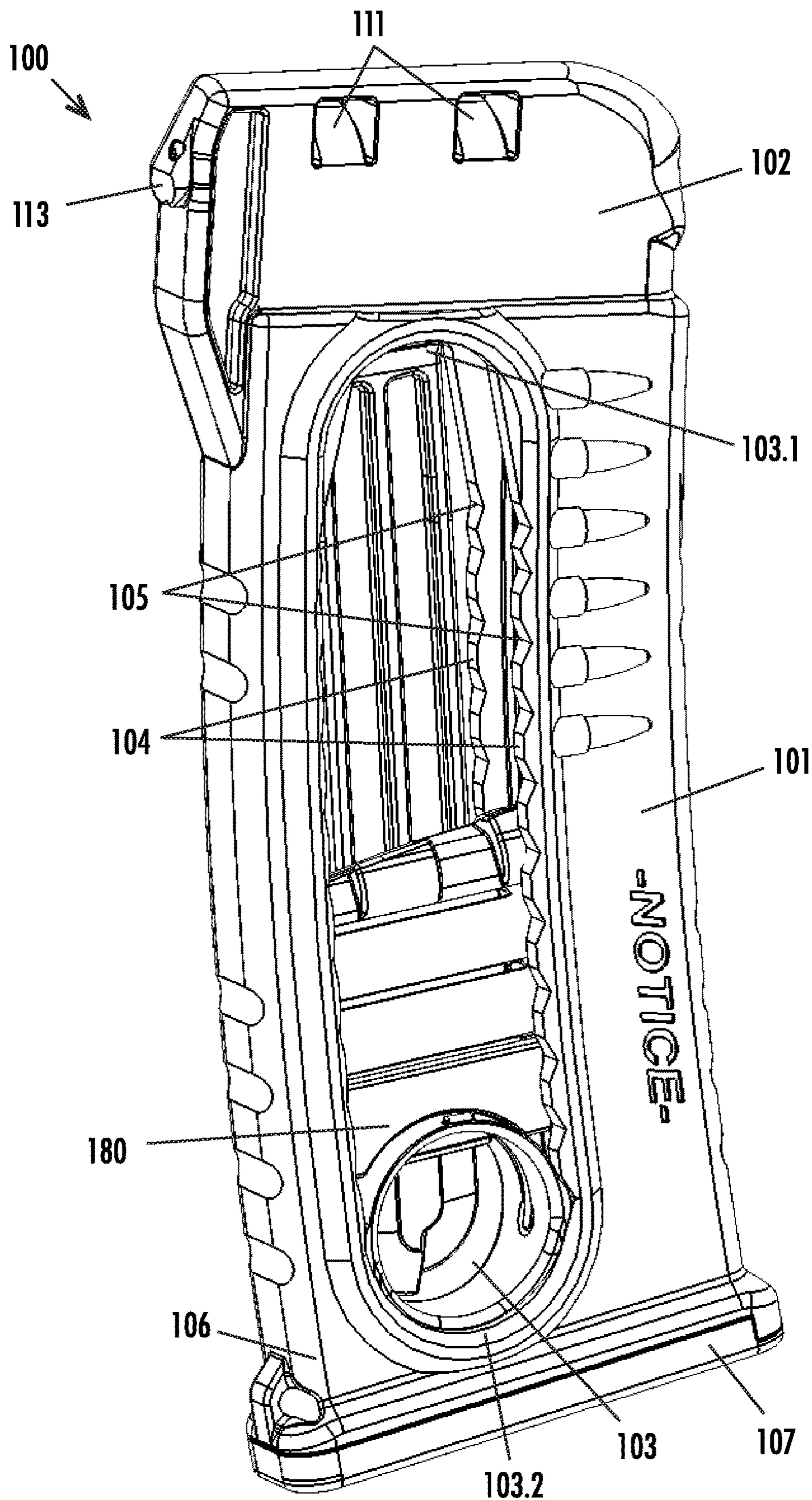

FIG. 11

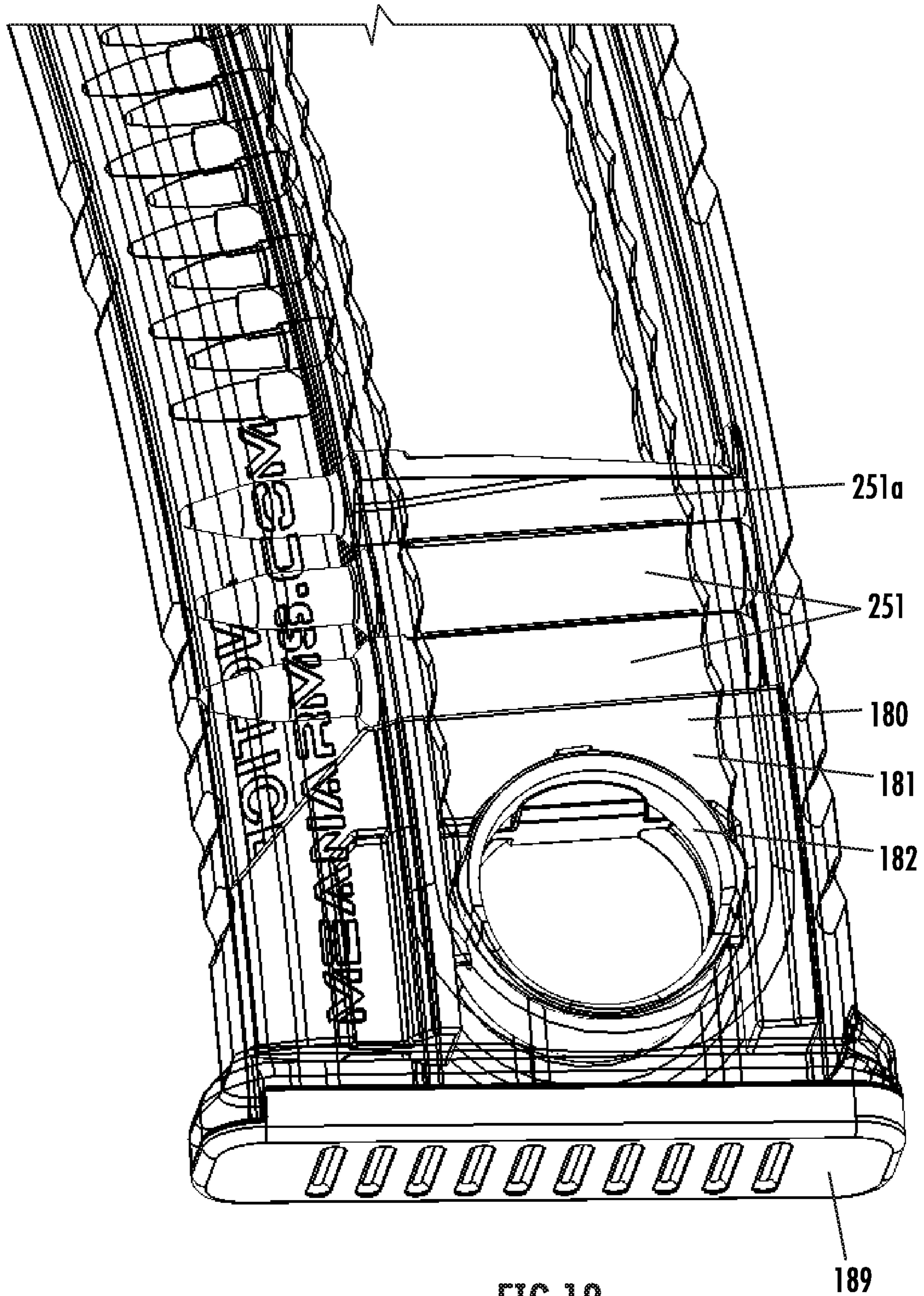

FIG.12

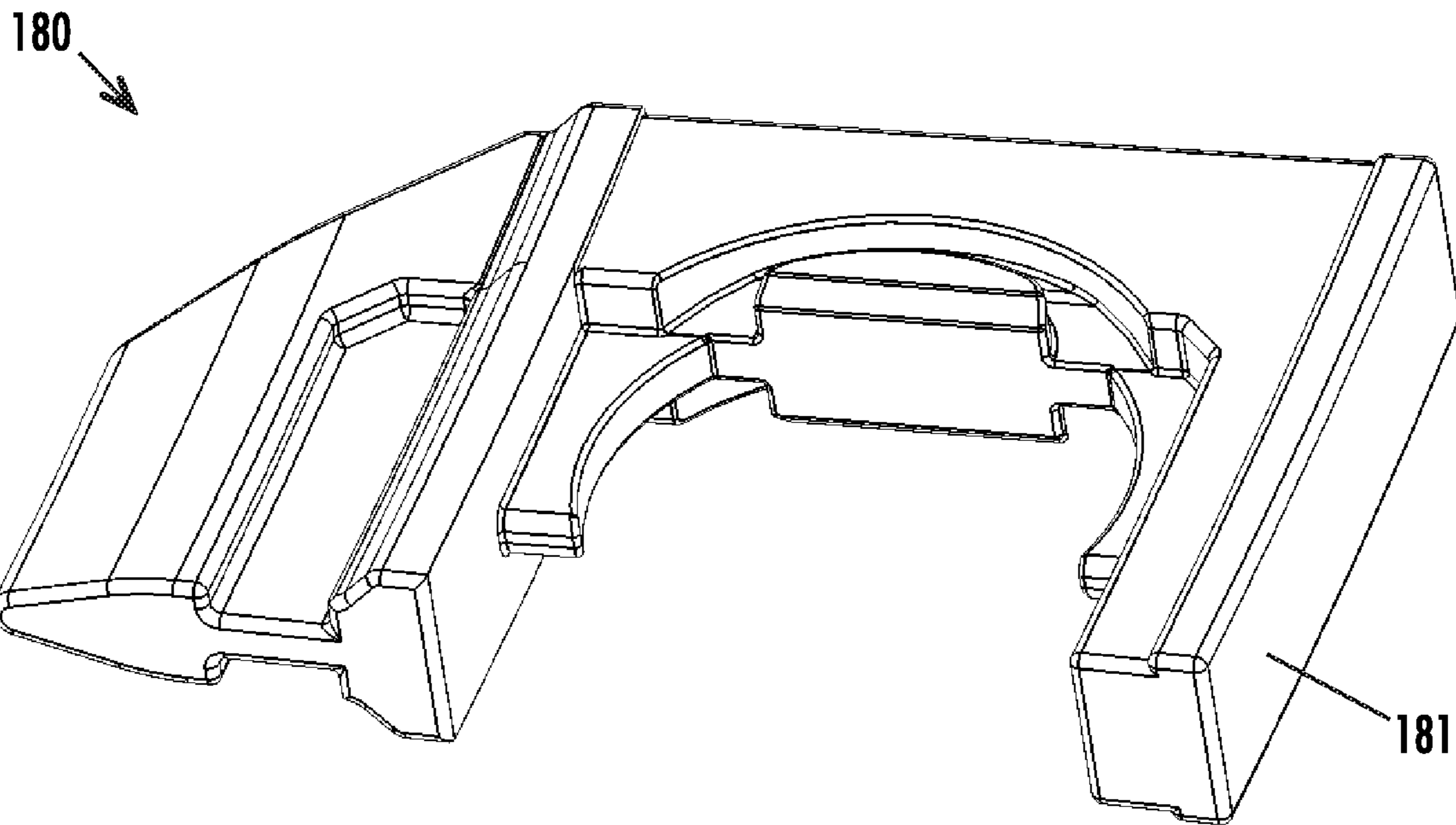

FIG. 13A

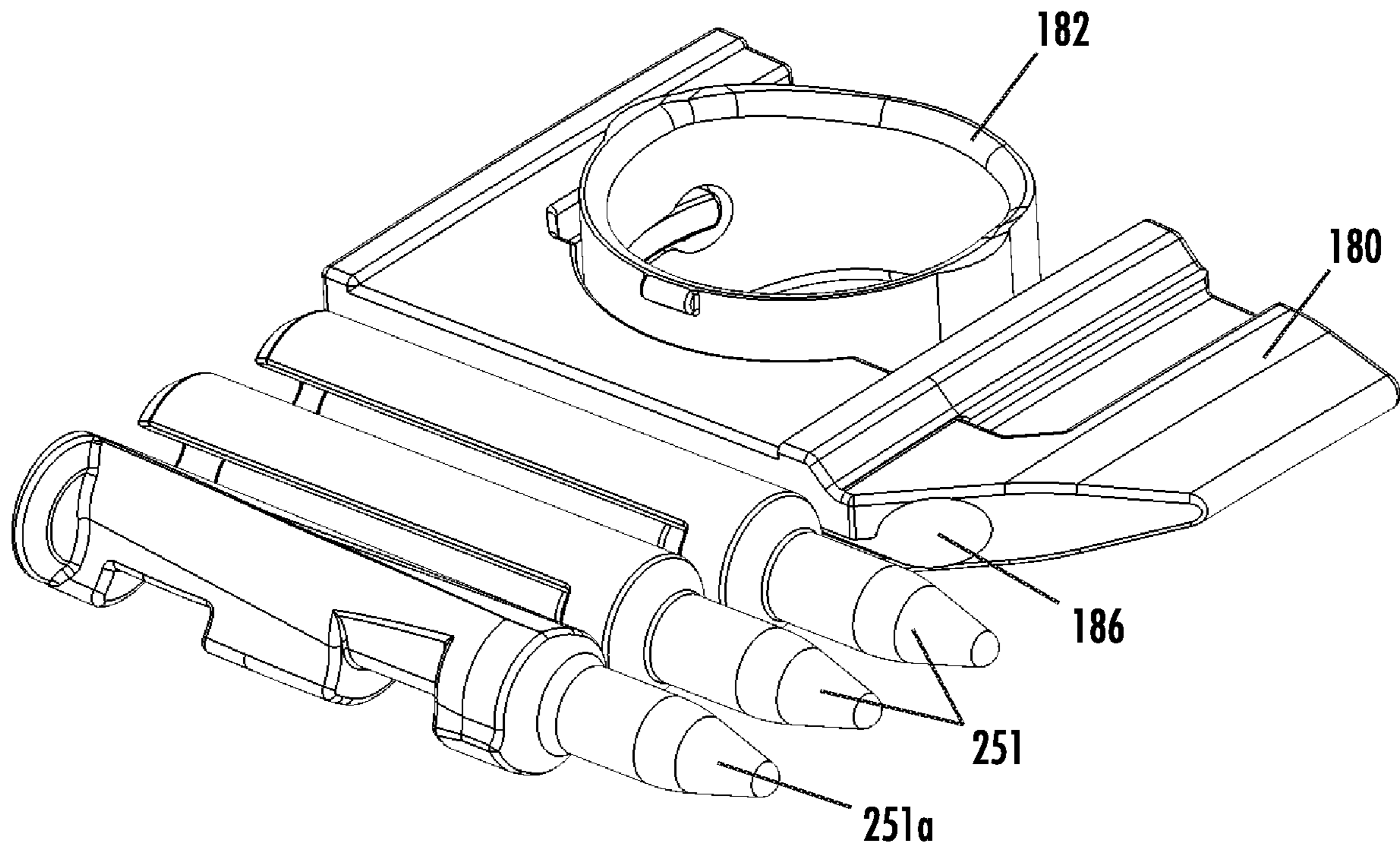

FIG. 13B

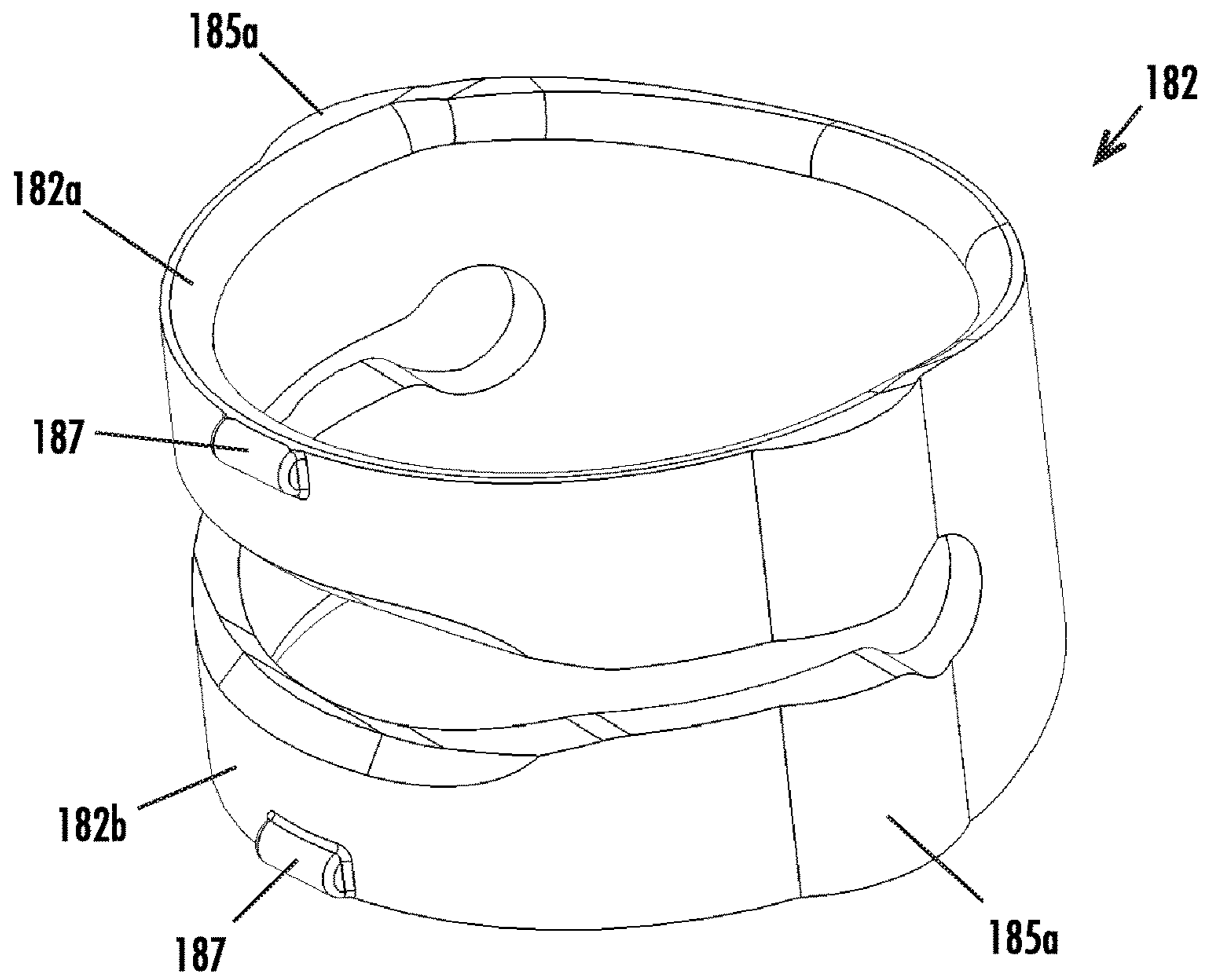

FIG. 14A

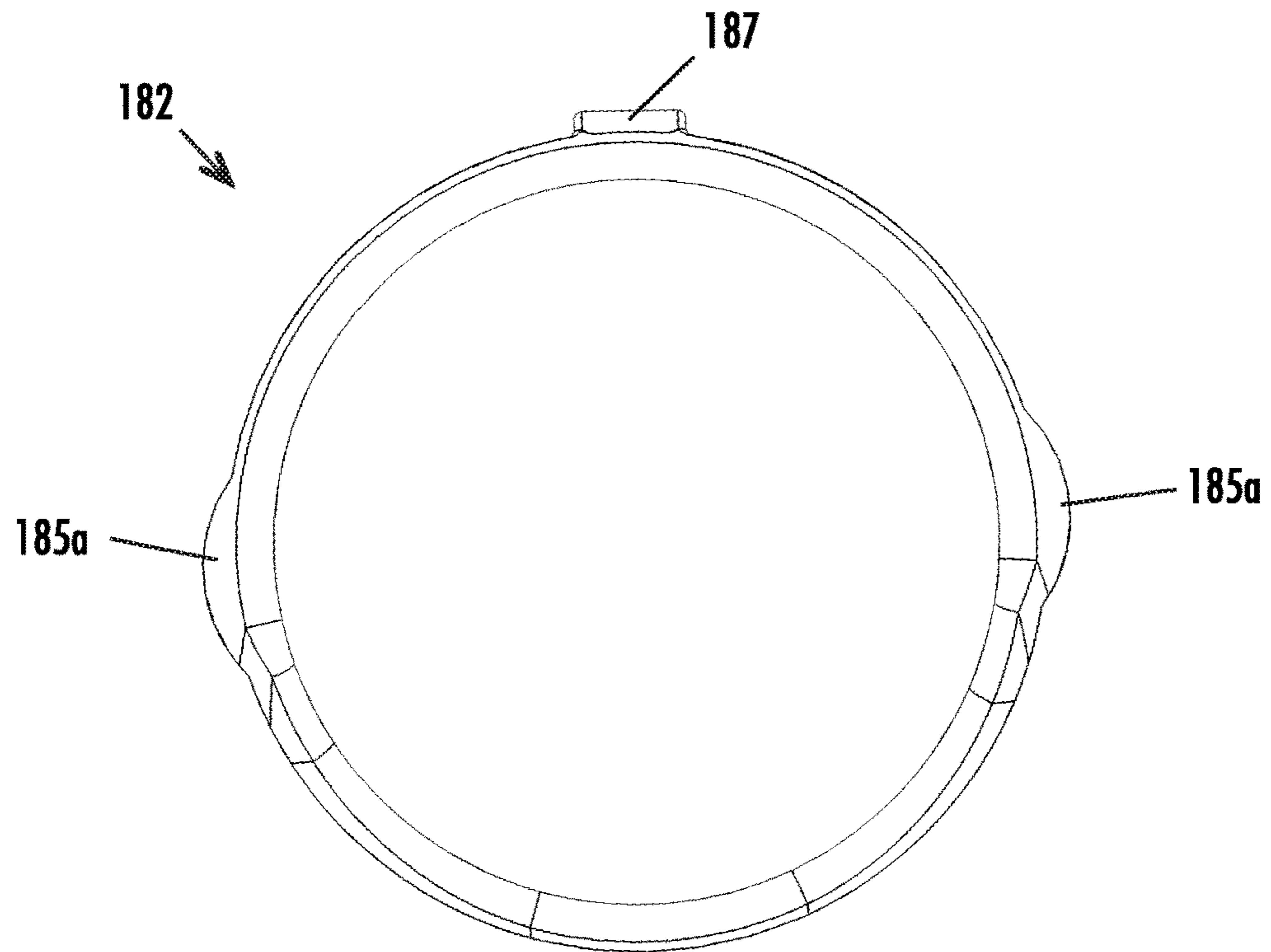

FIG. 14B

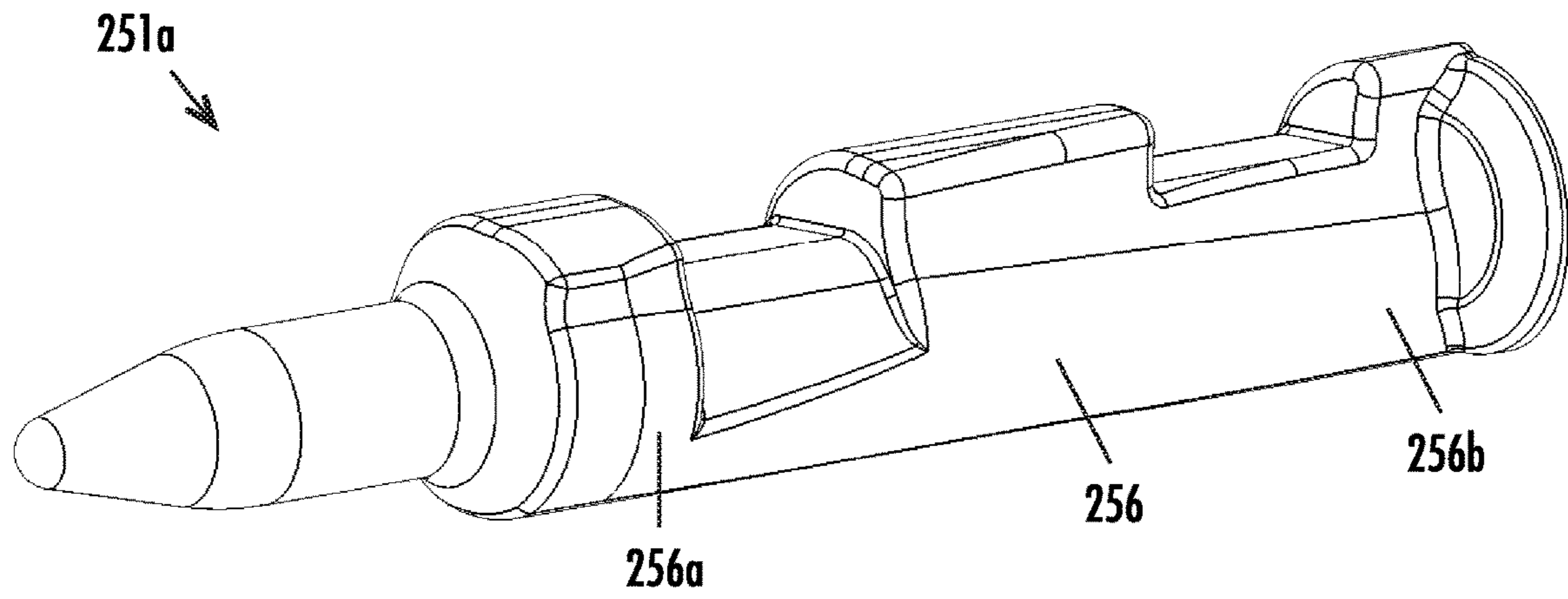

FIG. 15A

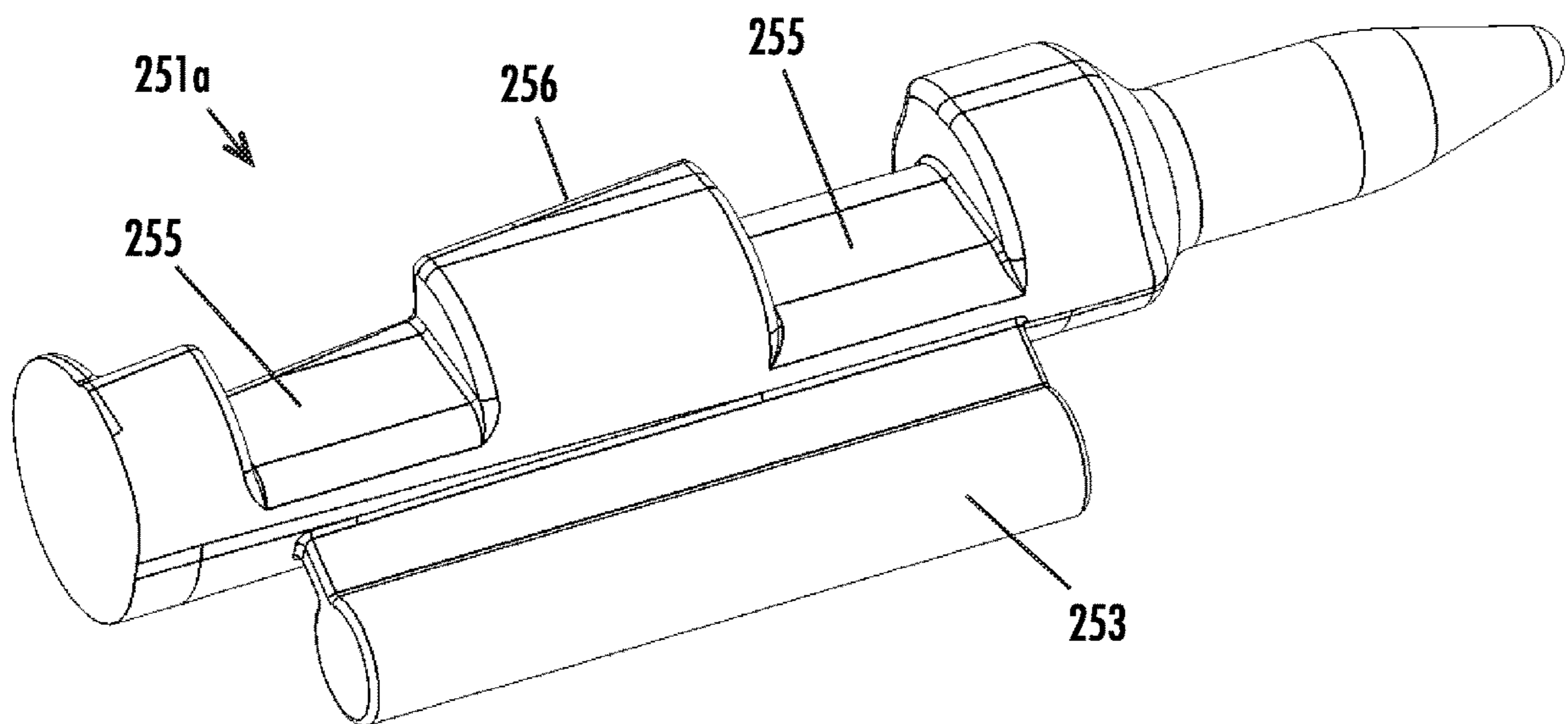
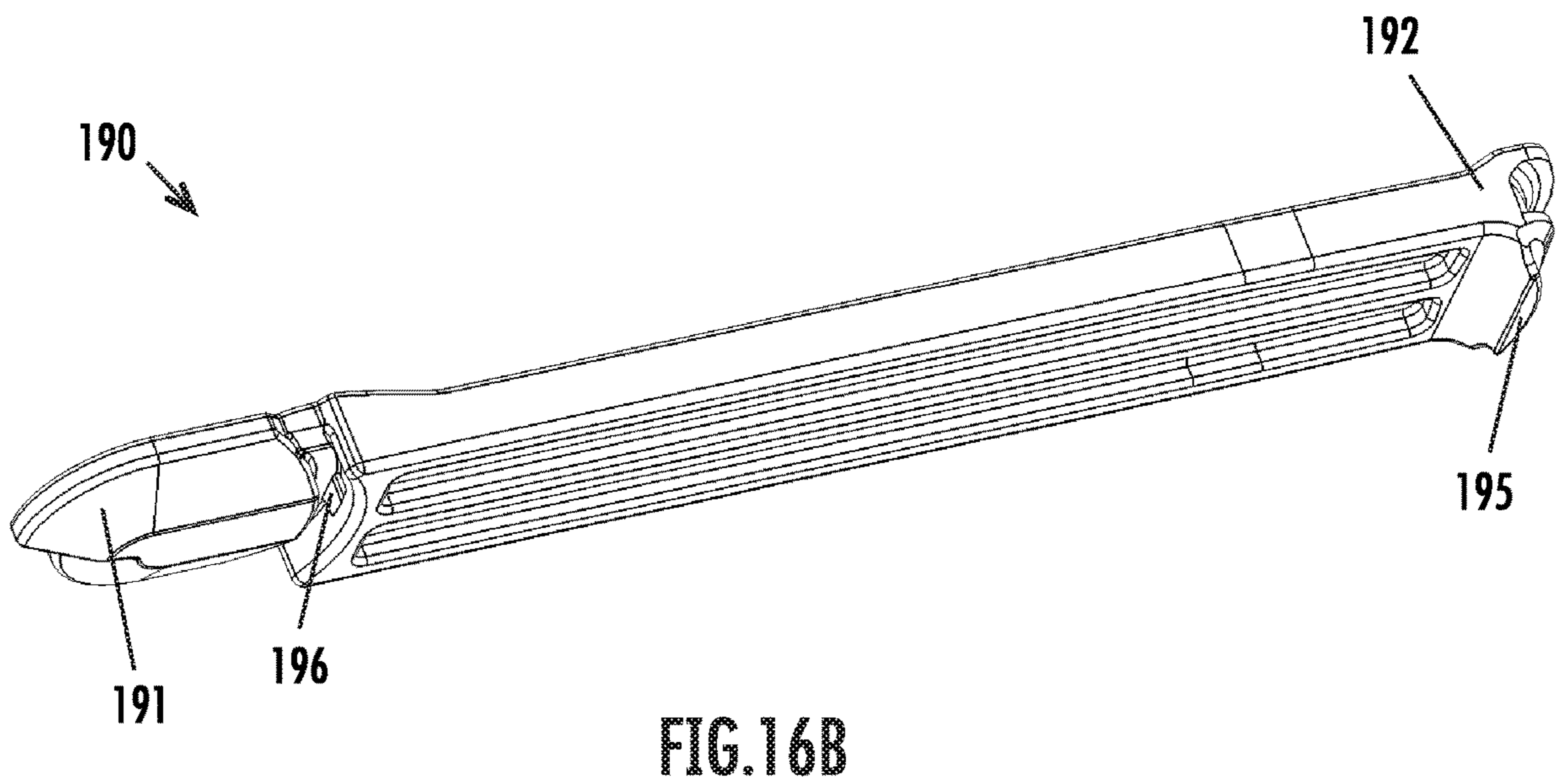
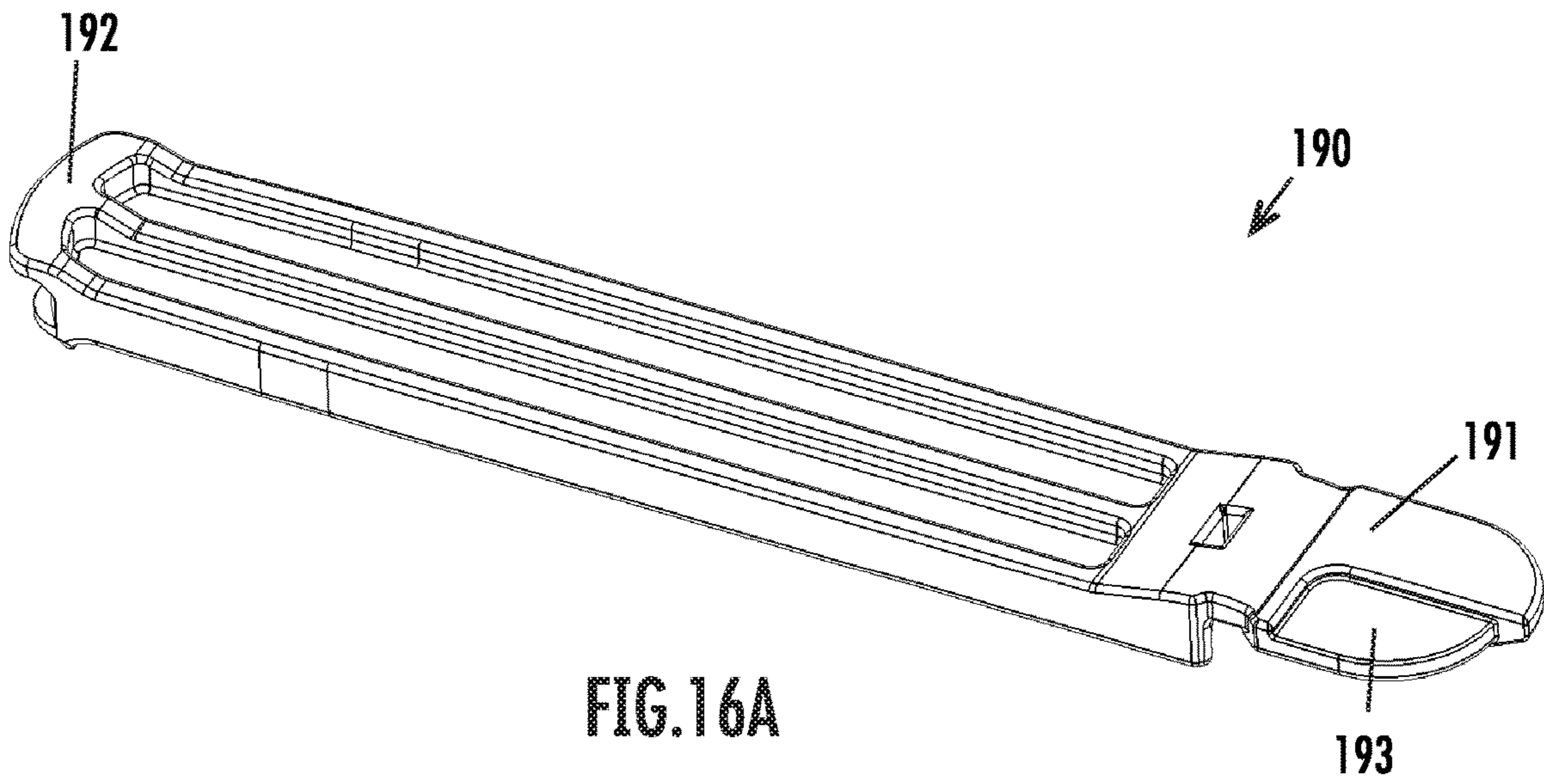

FIG. 15B



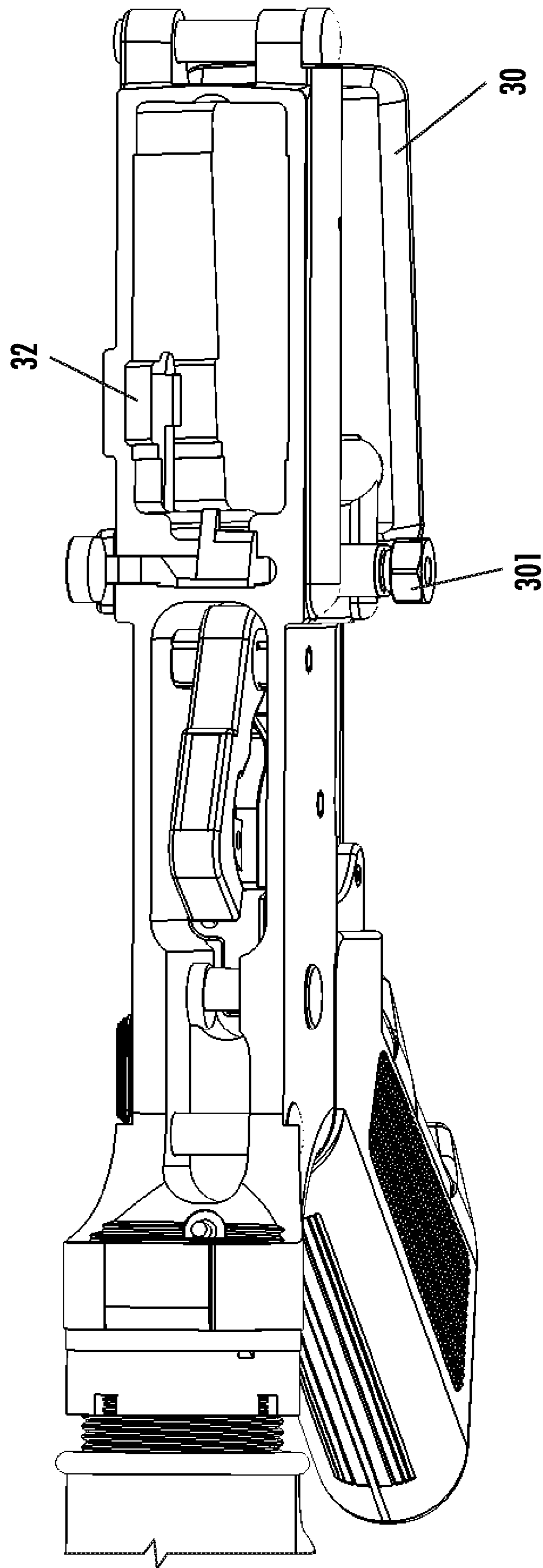

FIG. 16C

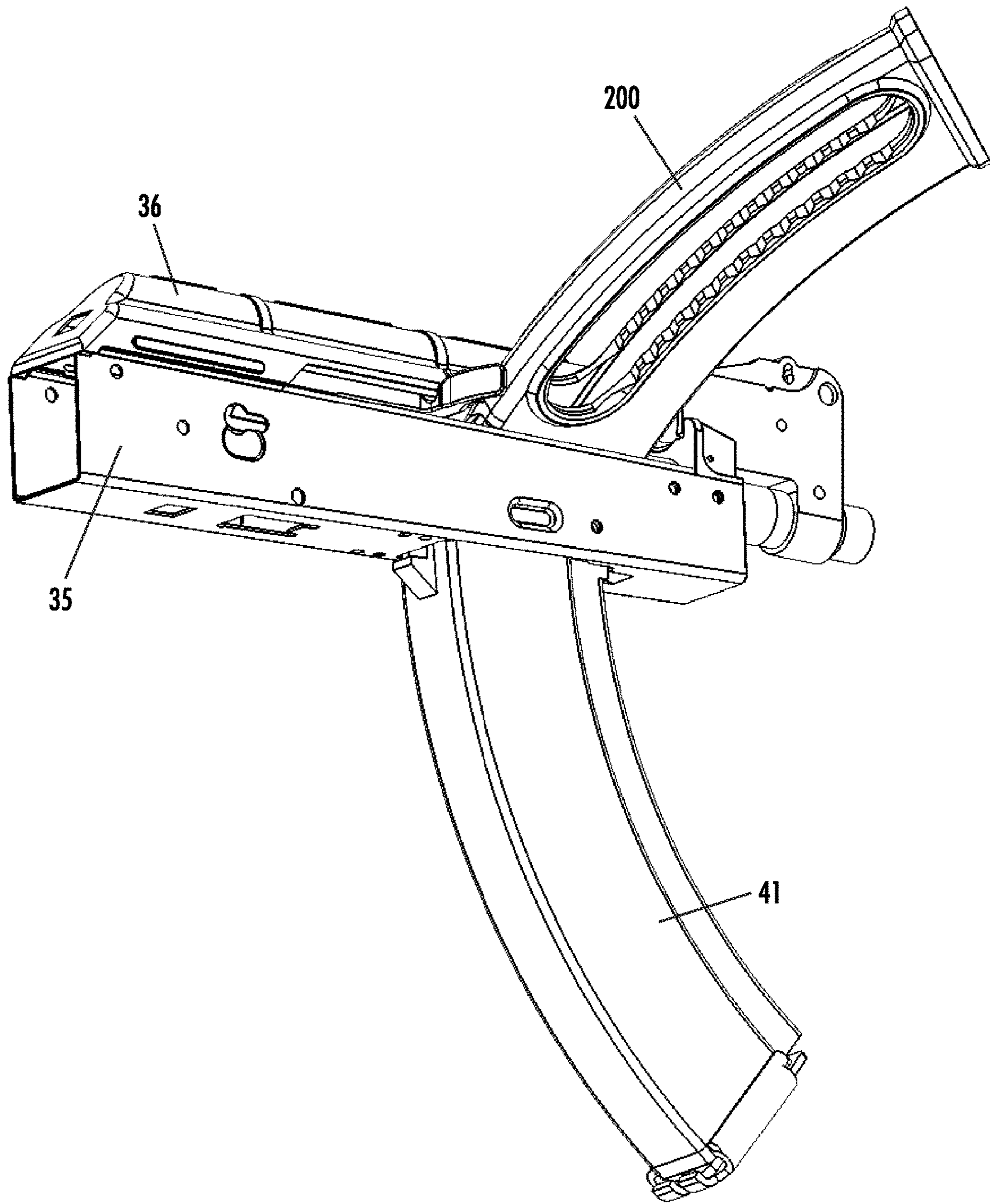

FIG.17

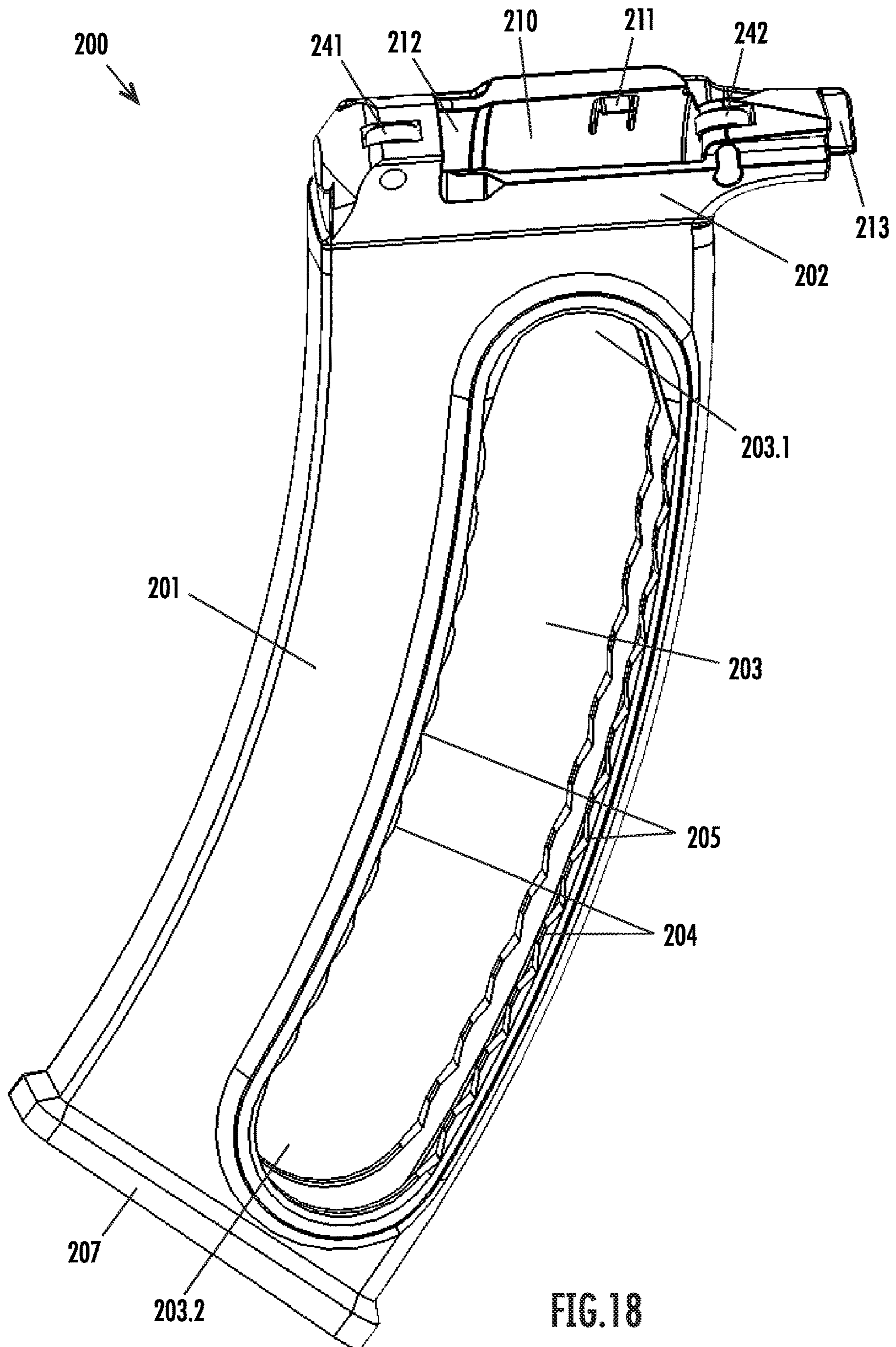

FIG. 18

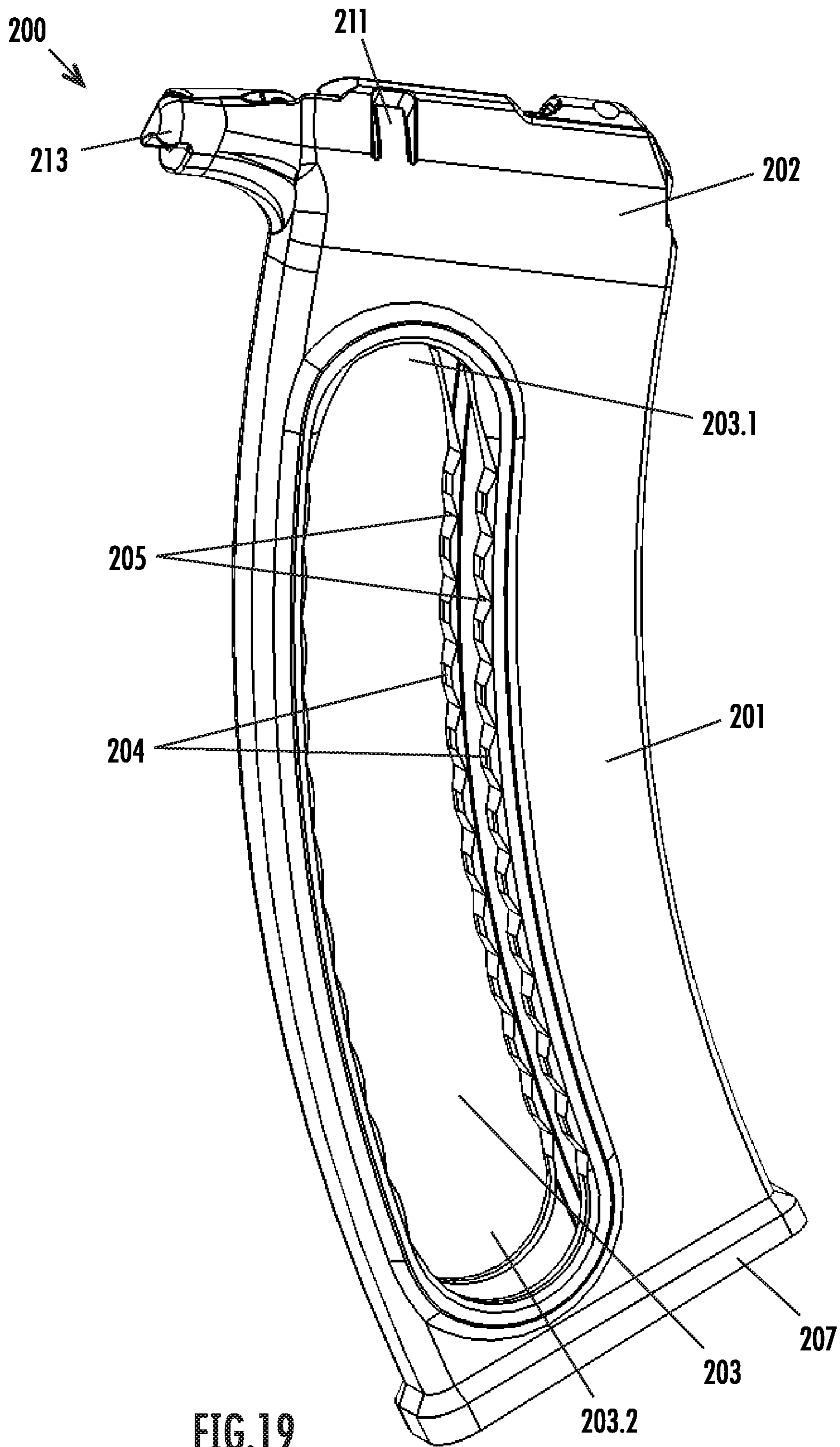

FIG. 19

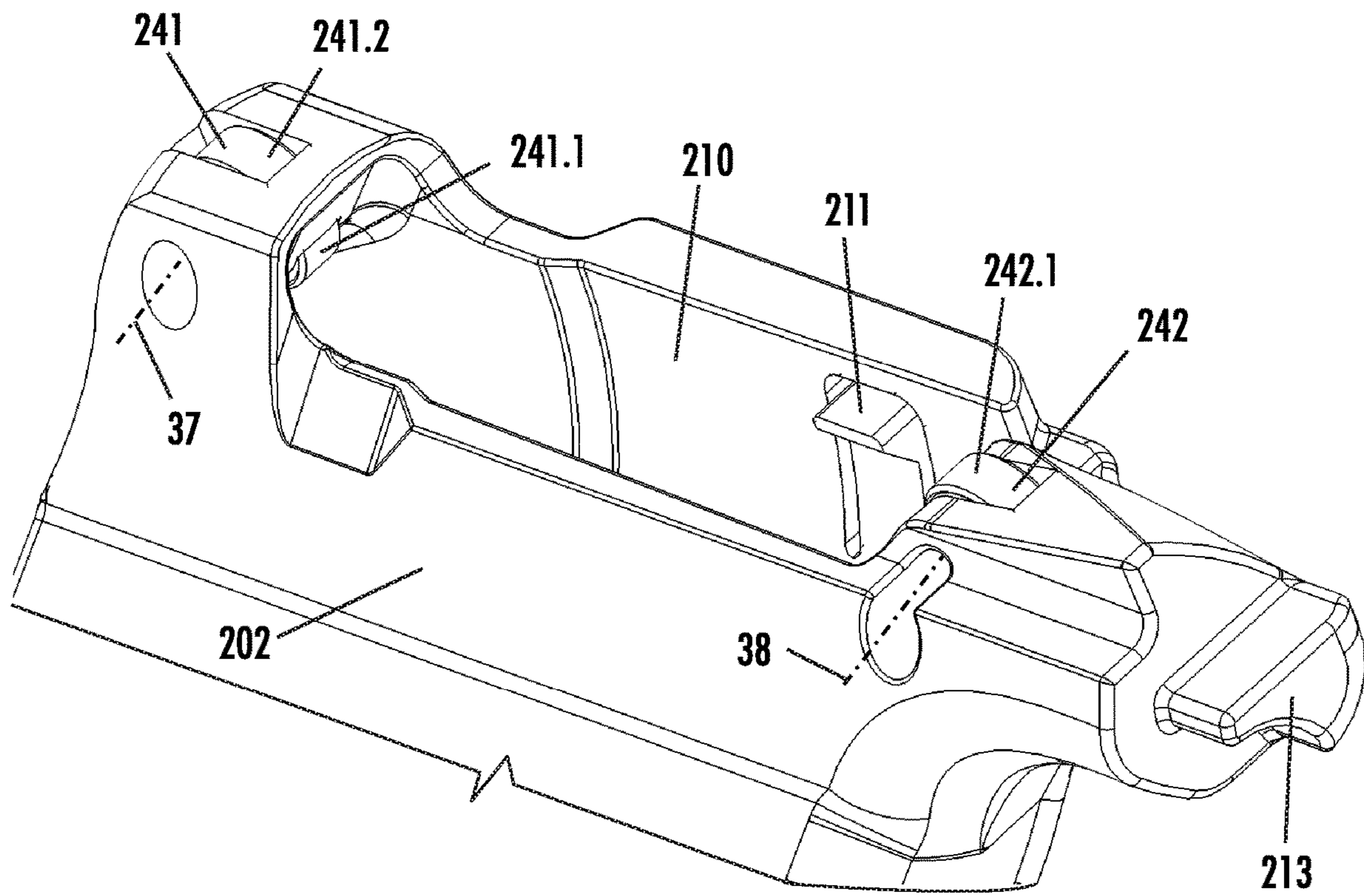

FIG. 20A

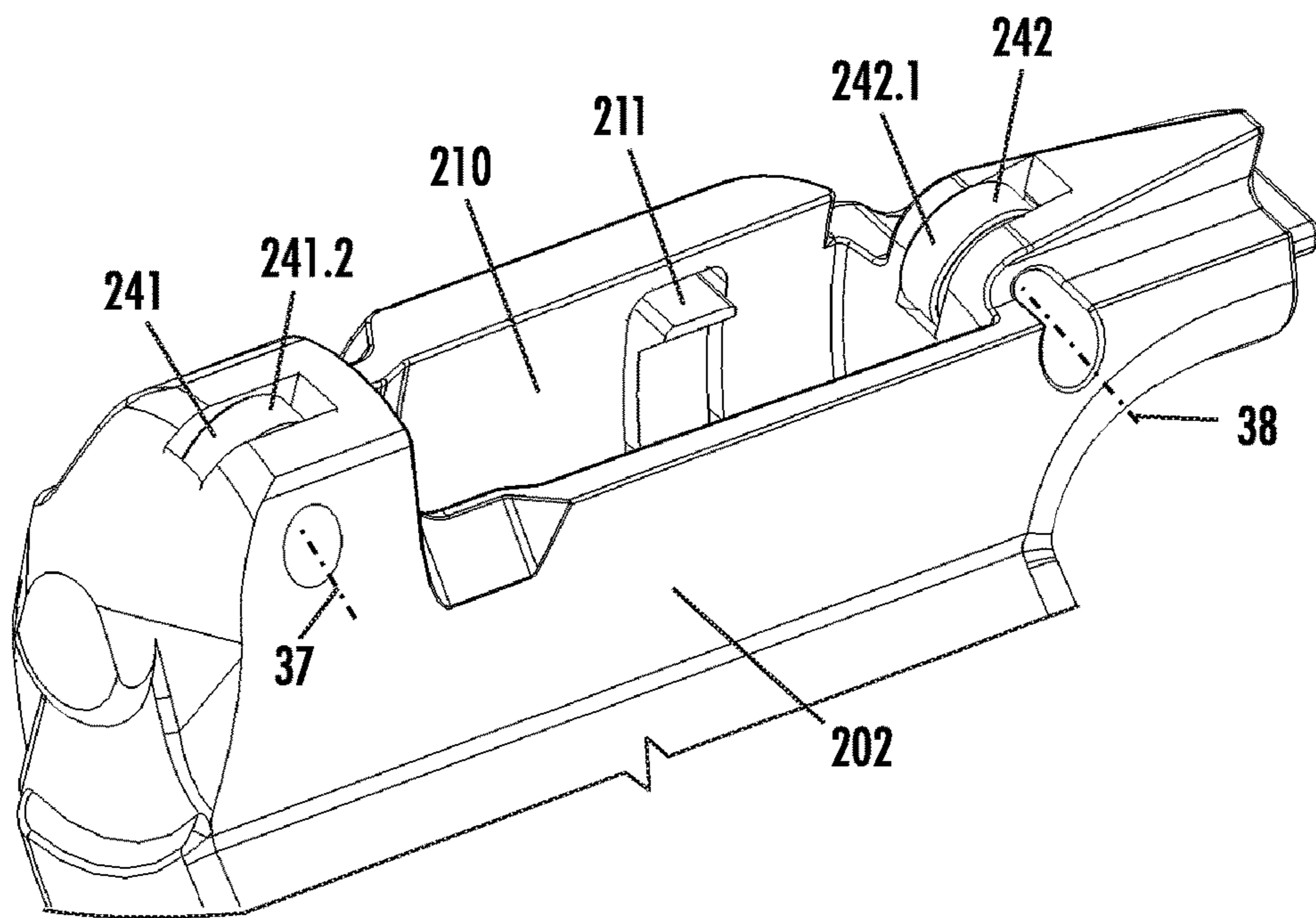

FIG. 20B

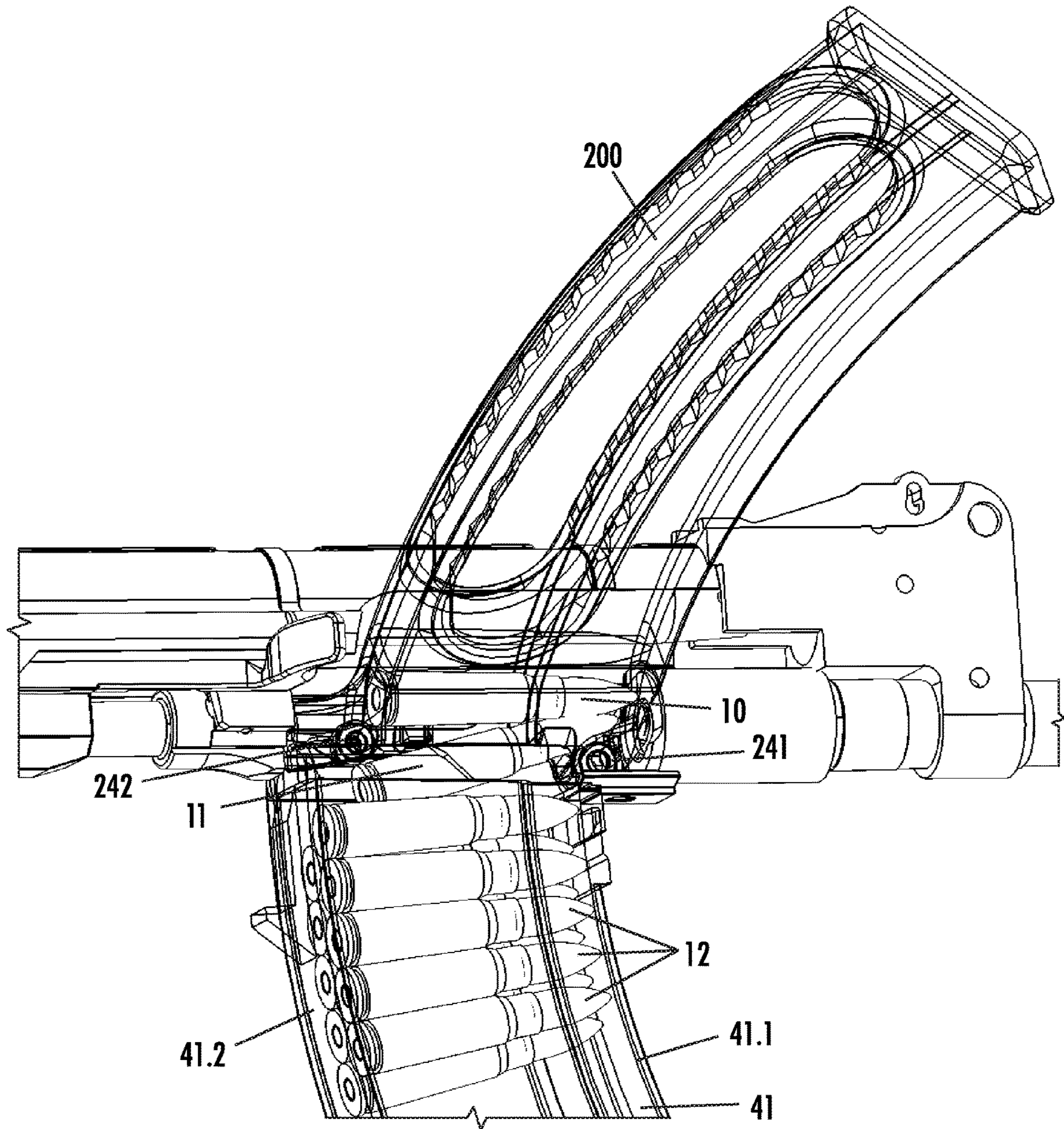

FIG. 21

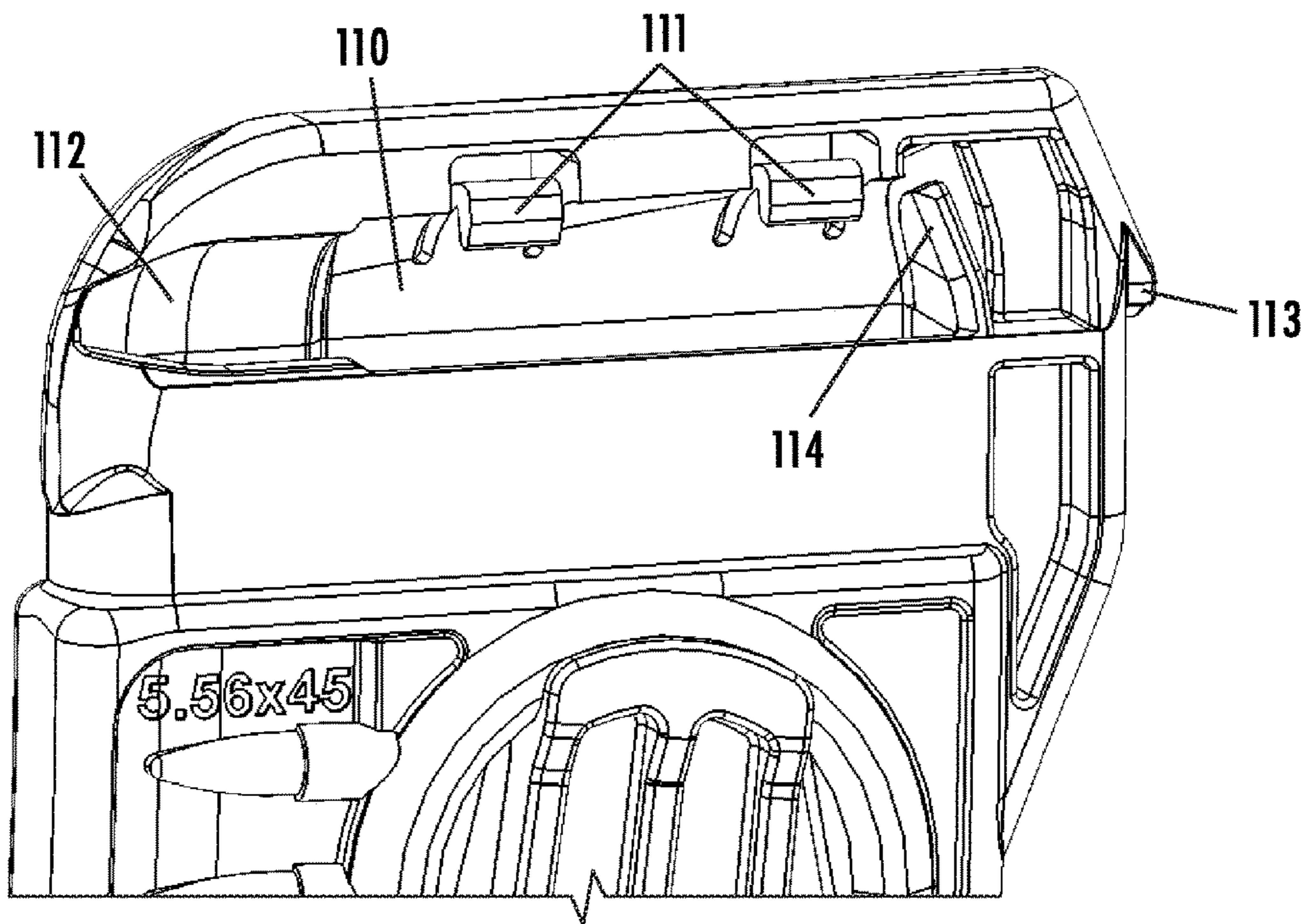

FIG. 22A

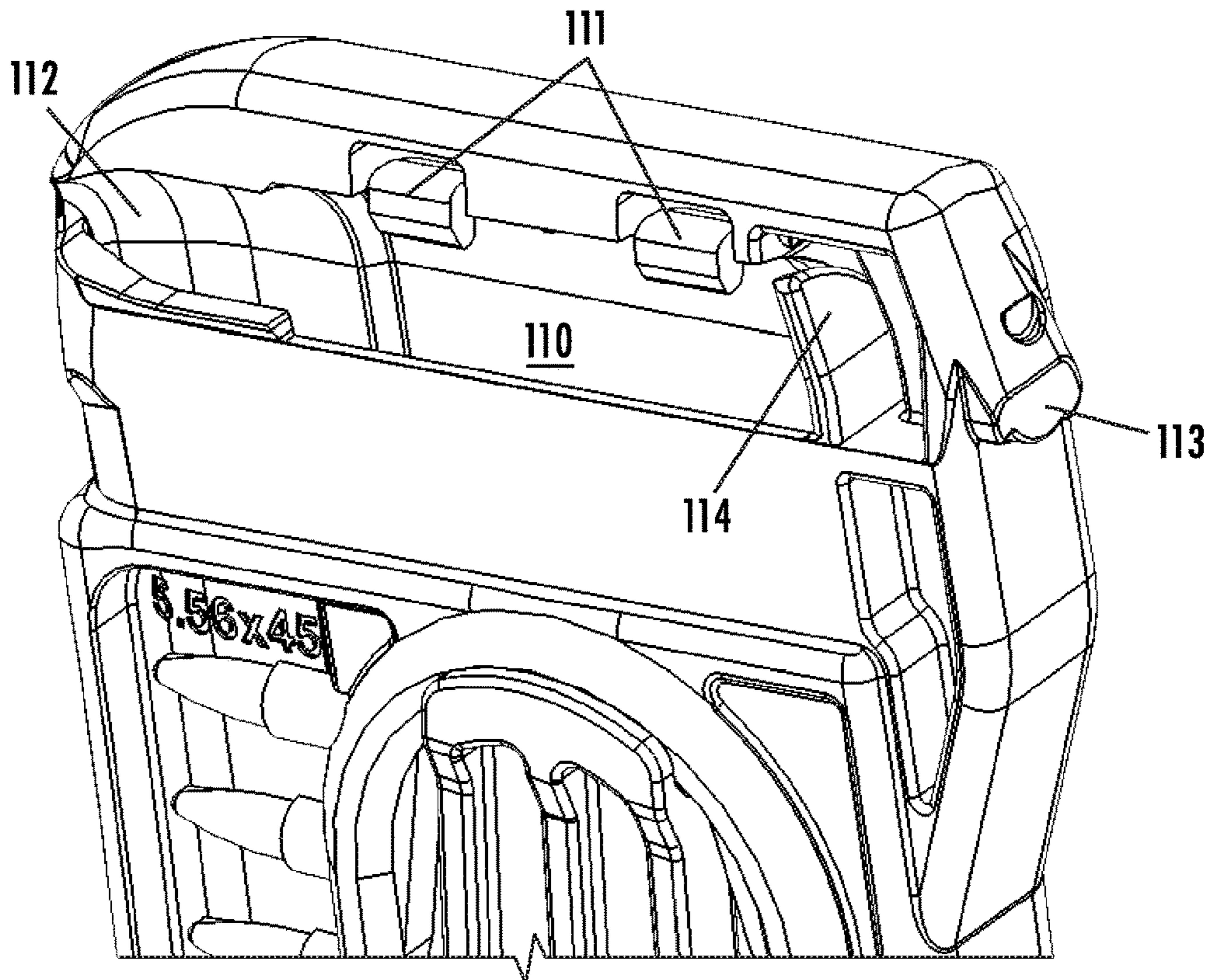

FIG. 22B

1**FIREARM LOCK****CROSS REFERENCE TO RELATED APPLICATIONS**

This application is a continuation of U.S. patent application Ser. No. 15/845,209 (“the ’209 application”) filed Dec. 18, 2017, which is related to and claims priority benefit from U.S. Provisional Application No. 62/435,535 (“the ’535 application”), filed on Dec. 16, 2016; U.S. Provisional Application No. 62/467,389 (“the ’389 application”), filed on Mar. 6, 2017; and U.S. Provisional Application No. 62/564,635 (“the ’635 application”), filed on Sep. 28, 2017. The ’209 application, the ’535 application, the ’389 application, and the ’635 application are hereby incorporated in their entireties by this reference.

FIELD OF THE INVENTION

The field of the invention relates to firearms, particularly methods and devices for locking a magazine into a firearm.

BACKGROUND

Since the advent and standardization of self-contained metallic cartridge ammunition, firearms have included systems and devices for loading and/or storing ammunition. Many modern firearms (including handguns, rifles, carbines, shotguns, etc.) include a magazine for storing ammunition. Magazines may be integral/fixed to the firearm or may be detachable. Different magazine arrangements include tube, box, rotary, drum, casket, pan, helical, saddle-drum, or various other arrangements.

Some anti-firearm laws, such as those enacted in California, ban the sale of many semi-automatic, centerfire rifles or semi-automatic pistols that do not have a fixed magazine. To facilitate loading of fixed magazine firearms, it may be desirable to find alternative devices and methods for loading ammunition that does not include a removable magazine. In addition, in some cases, loading devices may enable faster and more efficient loading of firearms with removable magazines.

SUMMARY

The terms “invention,” “the invention,” “this invention” and “the present invention” used in this patent are intended to refer broadly to all of the subject matter of this patent and the patent claims below. Statements containing these terms should be understood not to limit the subject matter described herein or to limit the meaning or scope of the patent claims below. Embodiments of the invention covered by this patent are defined by the claims below, not this summary. This summary is a high-level overview of various aspects of the invention and introduces some of the concepts that are further described in the Detailed Description section below. This summary is not intended to identify key or essential features of the claimed subject matter, nor is it intended to be used in isolation to determine the scope of the claimed subject matter. The subject matter should be understood by reference to appropriate portions of the entire specification of this patent, any or all drawings and each claim.

According to certain embodiments of the present invention, a firearm loader for transferring at least one cartridge to a firearm comprises: a main body comprising a proximal end and a distal end; and a follower disposed inside the main

2

body, wherein: the loader comprises an engaged configuration wherein the loader is at least partially inserted into a firearm; the proximal end comprises an opening; and in the engaged configuration, the opening approximately faces a magazine of the firearm.

BRIEF DESCRIPTION OF THE DRAWINGS

FIG. 1A is a front left partial perspective view of a firearm, according to certain embodiments of the present invention.

FIG. 1B is a rear right partial perspective view of the firearm of FIG. 1A.

FIG. 1C is a front right partial perspective exploded view of the firearm of FIG. 1A.

FIG. 2 is a bottom perspective view of a loader, according to certain embodiments of the present invention.

FIG. 3 is a top perspective view of the loader of FIG. 2.

FIG. 4 is a partial perspective view of the loader of FIG. 2.

FIGS. 5A and 5B are perspective views of a spacer of the loader of FIG. 2.

FIGS. 6A and 6B are perspective views of a follower of the loader of FIG. 2.

FIG. 6C is a partial perspective view of the follower of FIG. 2.

FIG. 7A is a rear right partial perspective view of a firearm, according to certain embodiments of the present invention.

FIG. 7B is a rear right partial perspective view of the firearm of FIG. 7A.

FIG. 8A is a perspective view of a lock of the firearm of FIG. 7A.

FIG. 8B is a cross section view of a lock of the firearm of FIG. 7A.

FIG. 9A is a right side perspective view of a lip member of the firearm of FIG. 7A.

FIG. 9B is a left side perspective view of a lip member of the firearm of FIG. 7A.

FIG. 10 is a bottom perspective view of a loader, according to certain embodiments of the present invention.

FIG. 11 is a top perspective view of the loader of FIG. 10.

FIG. 12 is a partial perspective view of the loader of FIG. 10.

FIGS. 13A and 13B are perspective views of a follower of the loader of FIG. 10.

FIG. 14A is a perspective view of a ring portion of the loader of FIG. 10.

FIG. 14B is a top view of a ring portion of the loader of FIG. 10.

FIGS. 15A and 15B are perspective views of a spacer of the loader of FIG. 10.

FIGS. 16A and 16B are perspective views of a tool of the loader of FIG. 10.

FIG. 16C is a partial top perspective view of the firearm of FIG. 7A.

FIG. 17 is a rear right partial perspective view of a firearm, according to certain embodiments of the present invention.

FIG. 18 is a bottom perspective view of a loader, according to certain embodiments of the present invention.

FIG. 19 is a top perspective view of the loader of FIG. 18.

FIGS. 20A and 20B are partial perspective views of a proximal end of the loader of FIG. 18.

FIG. 21 is a partial perspective view of the loader of FIG. 18 in an engaged configuration.

FIGS. 22A and 22B are partial perspective views of the loader of FIG. 10.

DETAILED DESCRIPTION

The subject matter of embodiments of the present invention is described here with specificity to meet statutory requirements, but this description is not necessarily intended to limit the scope of the claims. The claimed subject matter may be embodied in other ways, may include different elements or steps, and may be used in conjunction with other existing or future technologies. This description should not be interpreted as implying any particular order or arrangement among or between various steps or elements except when the order of individual steps or arrangement of elements is explicitly described.

Although the illustrated embodiments shown in FIGS. 1A-22B illustrate components of various semi-automatic or automatic rifles, the features, concepts, and functions described herein are also applicable (with potential necessary alterations for particular applications) to handguns, rifles, carbines, shotguns, or any other type of firearm. Furthermore, the embodiments may be compatible with various calibers including rifle calibers such as, for example, 5.56×45 mm NATO, .223 Remington, 7.62×51 mm NATO, .308 Winchester, 7.62×39 mm, 5.45×39 mm; handgun calibers such as, for example, 9×19 mm, .45 ACP, .40 S&W, .380 ACP; and shotgun calibers such as, for example, 12 gauge, 20 gauge, 28 gauge, .410 gauge, 10 gauge, 16 gauge.

According to certain embodiments of the present invention, as shown in FIGS. 1A-1C, a loader 100 may interface with a receiver of a firearm. The loader 100 may be a portable device capable of being inserted into and removed from a firearm (e.g., into an ejection port). In some embodiments, the loader 100 is inserted into the ejection port 21 (see FIG. 1C) of the upper receiver 20 of a firearm. The loader 100 facilitates the loading of at least one round of ammunition through the ejection port 21, through the upper receiver 20, through the lower receiver 30, and into the magazine 40. The loader 100 may facilitate loading of 5 rounds, 10 rounds, 20 rounds, 30 rounds, 40 rounds, or any other appropriate number of rounds. In some embodiments, magazine 40 is fixed in position. As shown in FIG. 1C, the loader 100 includes a follower 180.

In some embodiments, as shown in FIGS. 2 and 3, the loader 100 includes a main body 101, a proximal end 102, and a distal end 107 where the proximal end 102 may be inserted into the firearm. The main body 101 may include a channel 103 that extends at least partially through the thickness of the main body 101. The channel 103 may extend along at least part of the length of the main body 101. Near the distal end 107, the loader 100 may include grip features 106 such as serrations, checkering, stippling, or any other appropriate feature for enhancing grip.

At the proximal end 102, there is an opening 110 to allow cartridges to move from the loader 100 into the firearm (see FIGS. 2 and 10). The opening 110 may include at least one spring 111, which prevent cartridges from falling through the opening 110. To insert a cartridge into the loader 100, the cartridge may be pressed into the opening 110 causing the spring(s) 111 to move away from the opening 110. As shown in FIGS. 2 and 10, the opening 110 may include a profiled shape including a narrower portion 112 that approximately corresponds to the shape of the projectile end of a cartridge such that cartridges can only be inserted into the loader in one orientation. The spring(s) 111 also prevent cartridge(s) from exiting the loader 100 unless the follower 180 is pushed toward the proximal end 102 (causing the spring(s) 111 to deflect away from the opening 110). In addition, spring(s) 111 guide cartridge(s) into the firearm.

To use the loader 100, the operator of the firearm/loader pushes cartridges into the opening 110 with the projectile end of the cartridge aligned with the narrower portion 112 of the opening 110. As explained above, the cartridge will not pass through the opening 110 unless the operator presses the cartridge to deflect the spring(s) 111 away from the opening 110. When one or more cartridges are inside the loader 100, the cartridges press the follower 180 toward the distal end 103.2 of the opening 130. In some embodiments, cartridges press against a spacer 251 to move the follower 180 away from the opening 110.

In some embodiments, the loader 100 has an engaged configuration and a disengaged configuration. For example, the engaged configuration occurs when the loader 100 is inserted into the upper receiver 20 (as shown in FIGS. 1A and 1B) such that the opening 110 faces downward approximately toward the lower receiver 30 and the magazine 40. To insert the loader 100 into the upper receiver 20, the bolt (not shown) must be held open (e.g., after the last round in the magazine is fired, the bolt is held open) such that the ejection port 21 is open. When the proximal end 102 of the loader 100 is fully inserted into the upper receiver 20, the protrusion 113 (on the rear side of the proximal end 102) engages the face of the bolt. In addition, when the loader 100 is inserted into the upper receiver 20, the spring-loaded plunger 120 is compressed against an internal surface of the firearm. In particular, the spring-loaded plunger 120 may be pressed against the inner surface of the upper receiver 20 on the opposite side of the upper receiver 20 from the ejection port 21. Once the loader 100 is inserted into the ejection port 21 and engages the bolt face (using protrusion 113), the operator of the firearm may push the follower 180 toward the proximal end 102 (e.g., by moving/manipulating ring portion 182) to push cartridges from the loader 100 into the firearm. After all of the ammunition is transferred from the loader 100 to the firearm, the firearm operator engages the charging handle (not shown) to pull the bolt rearward (away from the protrusion 113). When the protrusion 113 is released from the bolt (due to movement of the charging handle), the spring-loaded plunger 120 pushes the loader 100 out of the upper receiver 20 such that the loader 100 is in the disengaged configuration (i.e., not inserted into the firearm).

In some embodiments, when the loader 100 is in the engaged configuration (inserted into the upper receiver 20), the loader 100 can be used to release the bolt of the firearm. In other words, the firearm may be stored with the loader 100 in the engaged configuration such that the loader holds the bolt in the open position (such that the firearm is non-operational). The loader 100 act as a chamber safe. The operator of the firearm may remove the loader 100 from the firearm to release the bolt to make the firearm operational.

As shown in FIGS. 2, 3, 10 and 11, the channel 103 includes a proximal end 103.1 and a distal end 103.2. The channel 103 may extend through a full thickness of the body 101 (as shown) or may extend partially through the thickness of the body 101 (i.e., one side of body 101 may include a solid wall such that channel 103 extends through half of the body 101). In some embodiments, the channel 103 may include a partial cover. One or more of the edges of the channel 103 extending between the proximal end 103.1 and the distal end 103.2 may include at least one locating feature, such as a series of protrusions 104 and recesses 105. The illustrated embodiments show a total of four series of protrusions 104/recesses 105 but embodiments with one, two, or three series are also contemplated.

At the distal end **107**, the loader **100** may have an opening which is too small for follower **180** to pass through (see FIG. **1C**) or, in some embodiments, may include a removable floor plate **189** (see FIG. **12**). The loader **100** may function whether or not the removable floor plate **189** is installed. In some examples, the removable floor plate **189** is available in a plurality of colors and/or patterns/designs such that multiple loaders may be distinguished from one another. The removable floor plate may also include at least one area for a label.

The follower **180** may interface with the channel **103** in one or more manners. As shown in FIGS. **6A**, **6B**, and **13A-14B**, the follower **180** may include a U-shaped body **181**, a ring portion **182**, at least one protrusion **183** adjacent to a leading edge of the follower **180**, and an interface channel **186**. The ring portion **182**, in certain embodiments, is split into two parts (first portion **182a** and second portion **182b**) and includes an expanded portion **184** at the trailing edge of the ring portion **182** and at least one indexing portion **185**. In some embodiments, when a maximum number of cartridges are inserted into the loader **100**, the follower **180** moves toward the distal end **103.2** of the channel **103** such that the expanded portion **184** of the ring portion **182** presses against the internal surface of the distal end **103.2** (to limit the travel of the follower **180**). In some embodiments, the follower **180** moves toward the distal end **103.2** such that the one protrusion(s) **183** press against the internal surface of the distal end **103.2** (to limit the travel of the follower **180**).

As shown in FIG. **6C**, in some embodiments, the first portion **182a** and the second portion **182b** may each include an indexing portion **185** including a V-shaped protrusion that extends in an axial direction and is inserted into one of the recesses **105** (between two protrusions **104**). To move the follower **180** along the length of the body **101**, a force may be exerted against the follower **180** (by pushing/pulling the ring portion **182**, pushing cartridges into the loader **100**, or in some other manner). Forces applied to the follower **180** along the length of the body **101** may cause one of the inclined surfaces of the indexing portion(s) **185** to press against an adjacent protrusion **104** causing the first portion **182a** and/or the second portion **182b** to deflect inward (toward one another). The first portion **182a** and the second portion **182b** deflect toward one another until the V-shaped protrusion of each indexing portion **185** can slide across the innermost surface **104a** of the protrusion **104**. The follower **180** moves linearly along the body **101** until the indexing portion(s) **185** reach another recess **105**, which causes the first portion **182a** and the second portion **182b** to move away from one another (acting as a spring) such that the indexing portion **185** is inserted into the recess **105**. In certain embodiments, the follower **180** is not biased (e.g., by a spring) toward either end of the body **101** and is held in a given position due to an interface between recesses **105**/protrusions **104** and the indexing portion(s) **185** (and/or indexing portion **185a**, described below).

In some embodiments, as shown in FIGS. **10-14B**, the ring portion **182** may be separable from the follower **180**. As shown in FIGS. **14A** and **14B**, the at least one indexing portion **185a** may extend from the ring portion **182** in a circumferential direction. The ring portion **182** may also include at least one protrusion **187**, which engages a recess **196** of the tool **190** when the tool **190** is in the installed position.

As shown in FIGS. **10**, **16A**, and **16B**, the loader **100** may include a multipurpose tool **190** that includes a first end **191** and a second end **192**. The tool **190** has an installed position such that (1) the second end **192** engages an inner edge of

the channel **103** at the proximal end **103.1** and (2) protrusion **187** of the ring portion **182** inserts into and engages recess **196**. When in the installed position, protrusion **195** extends into a pathway of the cartridges moving through the loader **100**. In some embodiments, the protrusion **195** increases perceived resistance felt when pushing the follower **180**/ring portion **182** toward the proximal end **102** of the loader **100**. The increased resistance occurs because (1) the protrusion **195** and tool **190** must deflect to allow the cartridge to pass and/or (2) the cartridge must move around the protrusion **195** (i.e., toward the top of the loader **100**).

The multipurpose tool **190** may also be disengaged from the loader **100**. After being disengaged, the first end **191** of the tool **190** may be used to perform functions relevant to the magazine **40**. As described below, in some embodiments, the magazine release mechanism may be disabled using the lock **301**. However, it may be necessary to service or remove the magazine **40**. After disengaging the takedown pin and/or the pivot pin so the upper receiver **20** can move or pivot relative to the lower receiver **30**, the interior of the lower receiver **30** is exposed as shown in FIG. **16C**. The tool **190** may be inserted along interior channel **32** such that the first end **191** of the tool **190** (including recessed area **193**) engages the magazine **40** to allow disassembly, removal, and/or detachment of the magazine **40**.

The leading edge of the follower **180** may include a spacer or other object that extends toward the proximal end **102** of the loader **100**. The spacer or other object may be an integral part of the follower **180** or may be removable. In some embodiments, the leading edge of the follower **180** may include provisions for attaching a spacer. For example, the follower **180** may include an interface channel **186** (see FIGS. **6A**, **6B**, and **13B**) for attaching one or more removable components, such as spacer **251**. As shown in FIGS. **5A** and **5B**, the spacer **251** includes a main body **252** and may have a shape that approximates a cartridge. The spacer **251** may include a corresponding interface component **253** that engages interface channel **186**. Although the spacer **251** is illustrated with a male engagement component (interface component **253**) and the follower **180** is illustrated with a female component (interface channel **186**), the arrangement may be reversed such that the follower **180** includes a male engagement component and the spacer **251** includes a female engagement component. The interface channel **186** may have an approximately circular cross section and the interface component **253** may include an approximately cylindrical tongue that can be inserted into the interface channel **186**. In some embodiments, the circular cross section of the tongue channel allows the spacer **251** to pivot with respect to the follower **180** as it follows the internal contour of the loader **100**. As shown in FIG. **5A**, the spacer **251** may include an auxiliary channel **254** such that an additional spacer **251** may be attached to the spacer **251**. As one example, FIG. **4** shows follower **180** with three attached spacers **251**.

In some embodiments, all of the spacers **251** are identical. However, as shown in FIGS. **12**, **13B**, **15A**, and **15B**, at least one of the spacers **251a** may have a different shape. For example, spacer **251a** may include at least one channel **255** that correspond or engage the spring(s) **111**. The spacer **251a** may also include an interface surface **256** configured to engage the surface of the last round inserted into the firearm from the loader **100**. In some embodiments, the interface surface **256** is curved or angled such that the first end **256a**, which is closer to the projectile end of a cartridge, protrudes further from the follower **180**. In other words, the first end **256a** of the interface surface **256** protrudes further into the

firearm than the second end **256b**. The second end **256b** is recessed within the spacer **251a** and/or is closer to the interface component **253** of the spacer **251a**. As shown in FIGS. **15A** and **15B**, spacer **251a** does not include an auxiliary channel **254**. However, in some embodiments, spacer **251a** may include an auxiliary channel **254** such that multiple spacers **251a** may be attached to one another and/or to the follower **180**.

In some embodiments, the magazine **40** is fixed to the firearm using a lock **301**. The lock **301**, which is shown in FIGS. **7A-8B** and **16C**, includes a shaft **302** and a head **303**. As shown in FIGS. **8A** and **8B**, the shaft **302** of the lock **301** includes a hollow portion with internal threads **304** and a necked down region **305**. The threads **304** engage the threads of the magazine catch **31** when the lock is inserted into the lower receiver **30** into the typical location of the magazine release button. Once the lock **301** has fully engaged the magazine catch **31**, sufficient torque is applied to the head **303** until the shaft **302** breaks at the necked down region **305**, which leaves the lock **301** permanently installed within the lower receiver **30** (i.e., the head **303** and a small portion of the shaft **302** are discarded). FIG. **7A** shows the lock **301** before the shaft **302** is broken (i.e., head **303** still installed) and FIG. **7B** shows the lock **301** after the shaft **302** has broken (i.e., lock **301** is permanently installed).

To facilitate insertion of the loader **100** into the upper receiver **20**, in some embodiments, the firearm may include a lip member **401**. As shown in FIGS. **7A** and **7B**, the lip member **401** may be installed surrounding the ejection port **21** of the upper receiver **20**. As shown in FIGS. **9A** and **9B**, the lip member **401** includes a hole **402** that approximately aligns with the ejection port **21** when the lip member **401** is installed. The lip member **401** may also include two attachment lugs **403** which can be attached to the ejection port cover lugs **22** of the upper receiver **20** (see FIG. **1C**). The lip member **401** is optional and not required for using the loader **100** with a firearm. However, in some embodiments, the lip member **401** at least (1) simplifies insertion of the loader **100** into the ejection port **21** and (2) reduces wear and scratches of the loader **100** and the upper receiver **20**. The lip member **401** may act as a funnel to help guide the loader **100** into the ejection port **21**.

According to certain embodiments of the present invention, as shown in FIGS. **17-21**, a loader **200** may interface with a firearm that includes a receiver **35**, a dust cover **36**, and a magazine **41**. Some components of loader **200** may be similar to loader **100**. In some embodiments, the loader **200** is inserted into the ejection port (see FIG. **17**) of the firearm. The loader **200** facilitates the loading of at least one round of ammunition through the ejection port, through the dust cover **36** and/or the receiver **35** and into the magazine **41**. The loader **200** may facilitate loading of 5 rounds, 10 rounds, 20 rounds, 30 rounds, 40 rounds, or any other appropriate number of rounds. In some embodiments, magazine **41** is fixed in position. Although not shown, the loader **200** may include a follower.

In some embodiments, as shown in FIGS. **18** and **19**, the loader **200** includes a main body **201**, a proximal end **202**, and a distal end **207** where the proximal end **202** may be inserted into the firearm. The main body **201** may include a channel **203** that extends at least partially through the thickness of the main body **201**. The channel **203** may extend along at least part of the length of the main body **201**.

At the proximal end **202**, there is an opening **210** to allow cartridges to move from the loader **200** into the firearm (see FIGS. **18**, **20A**, **20B**, and **21**). The opening **210** may include at least one spring **211**, which prevent cartridges from falling

through the opening **210**. To insert a cartridge into the loader **200**, the cartridge may be pressed into the opening **210** causing the spring(s) **211** to move away from the opening **210**. As shown in FIGS. **18**, **20A**, and **20B**, the opening **210** may include a profiled shape including a narrower portion **212** that approximately corresponds to the shape of the projectile end of a cartridge such that cartridges can only be inserted into the loader in one orientation. The spring(s) **211** also prevent cartridge(s) from exiting the loader **200** unless the follower is pushed toward the proximal end **202** (causing the spring(s) **211** to deflect away from the opening **210**). In addition, spring(s) **211** guide cartridge(s) into the firearm.

To use the loader **200**, the operator of the firearm/loader pushes cartridges into the opening **210** with the projectile end of the cartridge aligned with the narrower portion **212** of the opening **210**. As explained above, the cartridge will not pass through the opening **210** unless the operator presses the cartridge to deflect the spring(s) **211** away from the opening **210**. When one or more cartridges are inside the loader **200**, the cartridges press the follower toward the distal end **203.2** of the opening **230**. In some embodiments, cartridges press against a spacer to move the follower away from the opening **210**.

In some embodiments, the loader **200** has an engaged configuration. For example, when the loader **200** is inserted into the firearm (as shown in FIGS. **17** and **21**), the opening **210** faces downward approximately toward the magazine **41**. To insert the loader **200** into the firearm, the bolt (not shown) must be held open (e.g., after the last round in the magazine is fired, the bolt is held open) such that the ejection port is open. When the proximal end **202** of the loader **200** is fully inserted into the firearm, the protrusion **213** (on the rear side of the proximal end **202**) may engage the face of the bolt. Once the loader **200** is inserted into the ejection port and/or engages the bolt face (using protrusion **213**), the operator of the firearm may push the follower toward the proximal end **202** to push cartridges from the loader **200** into the firearm.

As shown in FIGS. **18** and **21**, the loader **200** may include at least one cartridge moving portion **241**, **242**, which may include a roller, wheel, low-friction coating or other component to facilitate movement of cartridges. As one example, a forward roller **241** and/or a rear roller **242** facilitates movement of cartridges from the loader **200** into the firearm. The forward and rear rollers **241**, **242** may have a toroid shape, a sphere shape, a cylinder shape, or any other appropriate shape. In some embodiments, the loader **200** does not include any rollers and, in some cases, may include a smooth surface and/or a low friction portion at the illustrated location of at least one of the forward and rear rollers **241**, **242**. FIG. **21** shows the loader **200** and part of the firearm (including magazine **41**) as transparent to illustrate the function of the loader **200**. Cartridge **10** is located within the loader **200**, cartridge **11** is partially inserted into the firearm, and cartridges **12** are located within magazine **41**. When a cartridge approaches opening **210**, the forward end of the cartridge contacts the interior exposed portion **241.1** of the forward roller **241** such that the rear end of the cartridge enters the firearm (see cartridge **11**). When exiting the loader **200**, the cartridge is offset relative to the magazine **41** such that the forward end of cartridge **11** is forward of the forward wall **41.1** of the magazine **41**. Once the rear end of cartridge **11** contacts the magazine follower (not shown) or a previously inserted cartridge **12**, the cartridge **11** slides rearward along forward roller **241** until the cartridge exits the loader **200** and the rear end of the cartridge approaches the rear wall **41.2** of the magazine **41** (see cartridges **12**). In

addition, the cartridge moves rearward such that the forward end of the cartridge is located rearward of the forward wall 41.1 of the magazine 41 such that cartridge 12 can be fully inserted into magazine 41.

As shown in FIGS. 22A and 22B, the loader 100 may include a flexible member 114. In some embodiments, the loader 100 (or loader 200) may include a flexible member 114 located adjacent to a longitudinal end of the opening 110 (or opening 210). The flexible member 114 is illustrated adjacent to the rear longitudinal end such that the flexible member 114 would be adjacent to a rear end of a cartridge exiting the opening 110 (or opening 210) of the loader. The flexible member 114 may act as a spring that pushes (and/or deflects) such that each cartridge can move an appropriate distance forward/aft when exiting the loader. The movement of the flexible member 114 may compensate for variations in internal geometry of various firearms/magazines. In some cases, the flexible member 114 accommodates or compensates for cartridges with various lengths (i.e., due to manufacturing tolerances, different grain count, etc.). In addition, because the flexible member 114 extends toward the interior of the loader (e.g., toward the interior of opening 110), once a cartridge exits the loader 100 (or loader 200), the flexible member 114 may prevent a cartridge from moving from the firearm back into the loader (i.e., the flexible member 114 may act as a check valve or a one-way valve).

The components of any of the firearms described herein may be formed of materials including, but not limited to, thermoplastic, carbon composite, plastic, nylon, steel, aluminum, stainless steel, high strength aluminum alloy, other plastic or polymer materials, other metallic materials, other composite materials, or other similar materials. Moreover, the components of the firearms may be attached to one another via suitable fasteners, which include, but are not limited to, screws, bolts, rivets, welds, co-molding, injection molding, or other mechanical or chemical fasteners.

Different arrangements of the components depicted in the drawings or described above, as well as components and steps not shown or described are possible. Similarly, some features and sub-combinations are useful and may be employed without reference to other features and sub-combinations. Embodiments of the invention have been described for illustrative and not restrictive purposes, and alternative embodiments will become apparent to readers of this patent. Accordingly, the present invention is not limited to the embodiments described above or depicted in the drawings, and various embodiments and modifications may be made without departing from the scope of the claims below.

The invention claimed is:

1. A magazine lock assembly for a firearm, the magazine lock assembly comprising:

a magazine catch comprising a unitary component having a first end with a protrusion for engaging a magazine and a second end with threads;

a spacer comprising a cavity; and

a lock member comprising a shaft, a head, and a hole extending through the head, wherein:

the shaft of the lock member is at least partially disposed within the cavity of the spacer;

in a permanently installed configuration, the magazine lock assembly permanently fixes the magazine to the firearm;

the lock member and the magazine catch are attached to one another by rotating the head of the lock member;

the shaft of the lock member comprises a necked down region such that the shaft is configured to shear apart at the necked down region;

in the permanently installed configuration, the head and a portion of the shaft separate from the magazine lock assembly at the necked down region; and

the hole through the head comprises a diameter smaller than a diameter of a hollow portion of the lock member and the hole extends through a full length of the lock member.

2. The magazine lock assembly of claim 1, wherein the shaft of the lock member comprises threads that correspond to the threads of the second end of the magazine catch.

3. The magazine lock assembly of claim 1, wherein the hollow portion of the lock member comprises internal threads that correspond to the threads of the second end of the magazine catch.

4. The magazine lock assembly of claim 1, wherein:

the cavity of the spacer is non-threaded;

and

at least a portion of the second end of the magazine catch is disposed inside the shaft of the lock member within the cavity of the spacer.

5. The magazine lock assembly of claim 1, further comprising an uninstalled configuration.

6. The magazine lock assembly of claim 5, wherein, in the uninstalled configuration, the lock member and the magazine catch are attached to one another and the head remains attached to the magazine lock assembly.

7. The magazine lock assembly of claim 1, wherein, in the permanently installed configuration, the head is detached from the magazine lock assembly such that the lock member cannot be detached from the magazine catch without damaging the lock member.

8. The magazine lock assembly of claim 1, wherein:

in the permanently installed configuration, an end of the shaft is approximately flush with an outer surface of the spacer.

9. The magazine lock assembly of claim 1, wherein:

the necked down region comprises a beveled surface that reduces in dimension when moving away from the head.

10. The magazine lock assembly of claim 1, wherein the necked down region is disposed on an outer surface of the shaft of the lock member.

11. The magazine lock assembly of claim 1, wherein, in the permanently installed configuration, the shaft of the lock member bottoms out within the cavity of the spacer.

12. A firearm comprising:

a magazine lock assembly, the magazine lock assembly comprises:

a magazine catch comprising a protrusion for engaging a magazine;

a spacer comprising a cavity;

a lock member comprising a shaft, a head, and a hole extending through the head;

an uninstalled configuration; and

a permanently installed configuration, wherein:

in the permanently installed configuration, the magazine lock assembly permanently fixes the magazine to the firearm;

the lock member and the magazine catch are attached to one another by rotating the head of the lock member;

11

the shaft of the lock member comprises a necked down region such that the shaft is configured to shear apart at the necked down region;

in the permanently installed configuration, the head and a portion of the shaft separate from the magazine lock assembly at the necked down region; and

the hole through the head comprises a diameter smaller than a diameter of a hollow portion of the lock member and the hole extends through a full length of the lock member.

13. The firearm of claim **12**, wherein the shaft of the lock member comprises threads for attachment to the magazine catch.

14. The firearm of claim **12**, wherein the hollow portion of the lock member comprises internal threads for attachment to the magazine catch.

15. The firearm of claim **12**, wherein:
and

at least a portion of the magazine catch and the shaft is disposed inside the shaft of the lock member within the cavity of the spacer.

16. The firearm of claim **12**, wherein, in the uninstalled configuration, the lock member and the magazine catch are attached to one another and the head remains attached to the magazine lock assembly.

17. The firearm of claim **12**, wherein, in the permanently installed configuration, the head is detached from the magazine lock assembly such that the lock member cannot be detached from the magazine catch without damaging the lock member.

18. The firearm of claim **12**, wherein the lock member comprises a beveled surface that reduces in dimension when moving away from the head.

19. The firearm of claim **12**, wherein the shaft of the lock member bottoms out in a static configuration within the cavity of the spacer.

12

20. A method of installing a magazine lock assembly in a firearm, the method comprising:

inserting a magazine catch into a first side of a firearm wherein the magazine catch comprises a first end with a protrusion for engaging a magazine and a second end with threads;

inserting a spacer comprising a cavity into the second side of the firearm;

inserting a lock member into a second side of the firearm wherein the lock member comprises a shaft, a head, and a hole extending through the head; and

attaching the lock member and the magazine catch to one another by rotating the head of the lock member, wherein:

a portion of at least one selected from the group of the magazine catch and the shaft is disposed within the cavity of the spacer;

attachment between the lock member and the magazine catch includes bottoming out the shaft of the lock member in a static configuration within the cavity of the spacer;

the magazine lock assembly permanently fixes the magazine to the firearm;

the shaft of the lock member comprises a necked down region such that the shaft is configured to shear apart at the necked down region;

in the permanently installed configuration, the head and a portion of the shaft separate from the magazine lock assembly at the necked down region; and

the hole through the head comprises a diameter smaller than a diameter of a hollow portion of the lock member and the hole extends through a full length of the lock member.

21. The method of claim **20**, further comprising rotating the head of the lock member until the head shears apart from the lock member.

* * * * *