



US011089892B2

(12) **United States Patent**
Manochio

(10) **Patent No.:** **US 11,089,892 B2**
(45) **Date of Patent:** **Aug. 17, 2021**

(54) **CYLINDRICAL CONTAINER**

FOREIGN PATENT DOCUMENTS

(71) Applicant: **Nicholas Michael Manochio**,
Middletown, NJ (US)

AU 2019100149 B4 7/2019
CN 201256842 Y 6/2009

(Continued)

(72) Inventor: **Nicholas Michael Manochio**,
Middletown, NJ (US)

OTHER PUBLICATIONS

(*) Notice: Subject to any disclaimer, the term of this patent is extended or adjusted under 35 U.S.C. 154(b) by 0 days.

Yongkang Sheng Qiang Stainless Steel Products Manufactory, "16Oz Sublimation Plastic Travel Mug With Insert Personalized Photo Coffee Mug With Removable Insert ", Product Information, retrieved on Feb. 10, 2020 from https://www.alibaba.com/product-detail/16oz-Sublimation-plastic-travel-mug-with_60761334059.html, 7 Pages.

(21) Appl. No.: **16/949,542**

(22) Filed: **Nov. 3, 2020**

(Continued)

(65) **Prior Publication Data**
US 2021/0186240 A1 Jun. 24, 2021

Primary Examiner — James N Smalley

Assistant Examiner — Madison L Poos

(74) *Attorney, Agent, or Firm* — Patrick Garrett; John Maldjian; Maldjian Law Group LLC

Related U.S. Application Data

(60) Provisional application No. 62/951,315, filed on Dec. 20, 2019.

(57) **ABSTRACT**

(51) **Int. Cl.**
A47G 19/22 (2006.01)

A cylindrical container comprising: a main body, to store a beverage or a solid material, having a top end and a bottom end; a plurality of side panels, attached to each other, to form an insulated cover around the main body; a bottom lid, having an exterior wall and an interior wall, wherein an outer surface of the interior wall comprises a bottom lid thread to be screwed onto the bottom end of the main body or a top end of the main body to fully enclose the cylindrical container; a standard lid, having an exterior wall and an interior wall, wherein an outer surface of the interior wall comprises an interior lid thread to be screwed onto an interior thread provided at the top end of the main body; and a vacuum seal lid, having a flat top portion and a ring portion, wherein the ring portion comprises an O-ring hole along a circumference of the ring portion for accepting an O-ring to create a vacuum seal.

(52) **U.S. Cl.**
CPC **A47G 19/2227** (2013.01); **A47G 19/2272** (2013.01); **A47G 19/2288** (2013.01)

(58) **Field of Classification Search**
CPC **A47G 19/2227**; **A47G 19/2272**; **A47G 19/2288**; **A47G 19/2205**

(Continued)

(56) **References Cited**
U.S. PATENT DOCUMENTS

1,180,132 A 7/1876 Hoard et al.
3,601,250 A 8/1971 Merila

(Continued)

20 Claims, 26 Drawing Sheets

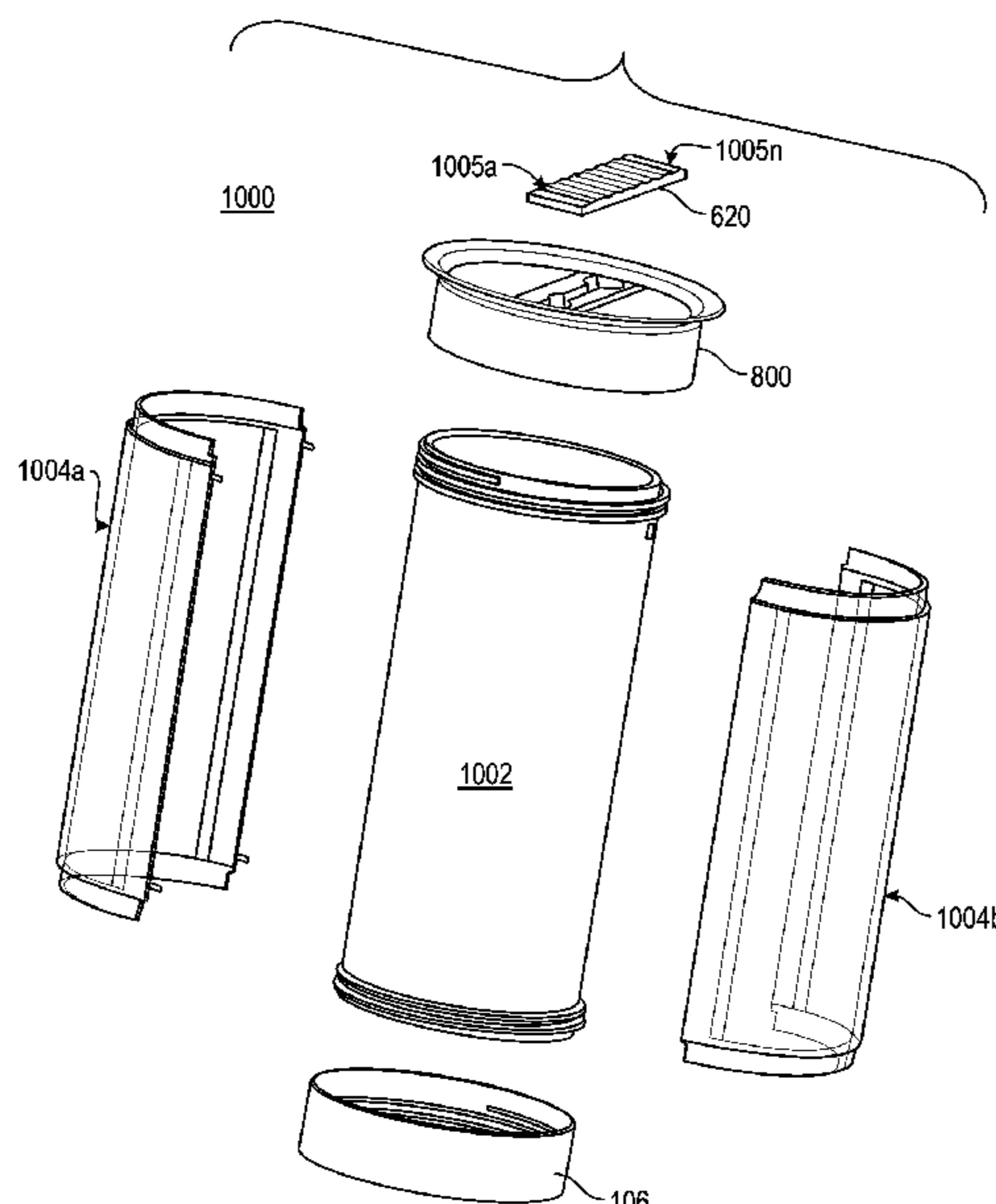

(58) **Field of Classification Search**
 USPC 220/592.17
 See application file for complete search history.

(56) **References Cited**

U.S. PATENT DOCUMENTS

3,732,999	A	5/1973	Rounkles	
3,946,895	A	3/1976	Pugh	
4,127,212	A	11/1978	Waterbury	
4,334,028	A	6/1982	Carver	
4,570,817	A	2/1986	Hambleton et al.	
5,040,317	A *	8/1991	Kadjevich	G09F 23/08 40/324
5,402,904	A	4/1995	Close	
5,429,364	A *	7/1995	Chang	A47G 19/2227 273/153 S
5,465,835	A	11/1995	Schumacher et al.	
5,525,383	A	6/1996	Witkowski	
5,531,353	A *	7/1996	Ward	A47G 19/2227 220/23.86
5,624,053	A	4/1997	Freek et al.	
5,729,922	A	3/1998	Peterson et al.	
5,913,442	A	6/1999	Wu	
5,918,761	A	7/1999	Wissinger	
6,196,413	B1	3/2001	Tung	
6,302,295	B1	10/2001	Weisman	
6,439,442	B1	8/2002	Markert et al.	
6,443,324	B1	9/2002	Buntain	
6,491,041	B1	12/2002	Okamoto	
6,520,369	B1	2/2003	Cytacki	
6,561,376	B2	5/2003	Price et al.	
6,752,287	B1	6/2004	Lin	
6,984,425	B2	1/2006	Raymond	
7,007,819	B2	3/2006	Pollack	
7,097,065	B2	8/2006	Yoneoka et al.	
7,275,653	B2	10/2007	Tedford, Jr.	
7,591,389	B2	9/2009	Wong	
7,703,226	B2	4/2010	Schnuckle	
7,753,224	B2	7/2010	Cai	
7,845,510	B2	12/2010	Schmidtner et al.	
7,900,384	B2	3/2011	Schnuckle	
8,046,941	B2	11/2011	Schnuckle	
8,281,929	B2	10/2012	Franks et al.	
8,381,935	B1	2/2013	Buck	
8,550,269	B2	10/2013	Lane	
8,695,839	B1	4/2014	Vanderberg	
8,714,403	B2	5/2014	Amprimo	
8,726,549	B2	5/2014	Regas	
8,757,404	B1	6/2014	Fleckenstein	
8,777,044	B1	7/2014	Raymus et al.	
8,870,010	B2	10/2014	Buck	
9,027,774	B2	5/2015	Palmer	
9,078,535	B1	7/2015	Buck	
9,119,507	B2	9/2015	Abrams et al.	
9,145,221	B2	9/2015	Kalyanpur et al.	
9,380,898	B2	7/2016	Mason	
9,390,633	B2	7/2016	Corbett	
9,565,958	B2	2/2017	Liu et al.	
9,603,471	B2	3/2017	Green	
9,604,747	B2	3/2017	Torres	
9,776,765	B2	10/2017	Stephens et al.	
9,856,053	B2	1/2018	Pisarevsky	
10,144,551	B2	12/2018	Ni	
10,183,789	B1	1/2019	Lin	
10,232,993	B2	3/2019	Seiders	
10,433,664	B2	10/2019	Brannock	
10,669,070	B2	6/2020	Lane, II et al.	
2002/0030063	A1	3/2002	Leray et al.	
2003/0146221	A1	8/2003	Lauer et al.	
2004/0049957	A1	3/2004	Richards	
2004/0056037	A1	3/2004	Richards	
2005/0040052	A1	2/2005	Dixon	
2005/0082295	A1	4/2005	Jagger et al.	
2006/0028014	A1	2/2006	McQueeney et al.	
2006/0131188	A1	6/2006	Lindemann	
2006/0191932	A1	8/2006	Bocola	

2008/0142520	A1	6/2008	Morgan	
2008/0149589	A1	6/2008	Lach	
2008/0171153	A1	7/2008	Weston et al.	
2008/0202950	A1	8/2008	Anderson	
2008/0296181	A1	12/2008	Stephens et al.	
2008/0296246	A1	12/2008	Chow	
2009/0026218	A1	1/2009	Wong	
2009/0101654	A1	4/2009	Brashear	
2010/0264152	A1	10/2010	Hirst et al.	
2011/0198355	A1	8/2011	Mullen	
2012/0012551	A1	1/2012	Sinacori et al.	
2012/0205371	A1	8/2012	Lee	
2012/0298676	A1	11/2012	Cooks	
2013/0233871	A1	9/2013	Gluck	
2014/0069946	A1	3/2014	Gubitosi et al.	
2016/0088960	A1*	3/2016	Liang	B65D 81/3869 220/560.01
2016/0174743	A1	6/2016	Childs	
2016/0304247	A1	10/2016	Lewis, Jr. et al.	
2017/0071376	A1	3/2017	Vandenlangenberg	
2017/0121074	A1*	5/2017	Seiders	B65D 51/1605
2017/0245624	A1	8/2017	Neves	
2017/0337725	A1	11/2017	White et al.	
2018/0140120	A1	5/2018	Shackelford	
2018/0289185	A1	10/2018	Oakes	
2019/0053649	A1	2/2019	Novak et al.	
2019/0117000	A1	4/2019	Lockhart et al.	
2019/0218011	A1	7/2019	Wang	
2019/0263573	A1	8/2019	Taylor	
2019/0274457	A1	9/2019	Robertson	
2020/0140135	A1	5/2020	Deylamian et al.	

FOREIGN PATENT DOCUMENTS

CN	202653465	U	1/2013
CN	202723386	U	2/2013
CN	203000271	U	6/2013
CN	203234227	U	10/2013
CN	203638438	U	6/2014
CN	204236947		4/2015
CN	206243737	U	6/2017
CN	207733976	U	8/2018
CN	208425836	U	1/2019
CN	210149917	U	3/2020
CN	210446790	U	5/2020
CN	210734961	U	6/2020
DE	102017120822	A1	3/2019
EP	3575230	A1	12/2019
FR	2690671	A1	11/1993
GB	2433418	A	6/2007
GB	2484270	A	4/2012
GB	201209315		7/2012
KR	20110106033	A	9/2011
KR	20150094209	A	8/2015
KR	101919108	B1	2/2019
TW	M435434	U	8/2012
TW	I680083	B	12/2019
WO	9426602	A1	11/1994
WO	02/059009	A1	8/2002
WO	2004048216	A1	6/2004
WO	2007134377	A1	11/2007
WO	2019184396	A1	10/2019

OTHER PUBLICATIONS

Shenzhen Biansebao Arts & Crafts Compan Ltd, "450MI Double Wall Removable Paper Insert Plastic Coffee Mugs Paper Insert Mug", Product Information, retrieved on Feb. 10, 2020 from https://www.alibaba.com/product-detail/450ml-Double-Wall-Removable-Paper-Insert_60472835583.html, 4 Pages.

Tantra, "Tantra Magic Bottle Tumbler, Suction Cup, Non-Spill Mug, Mighty Mug, Office Bottle, Gym Sports Sipper Bottle Capacity-540MI", Product Information, retrieved on Feb. 10, 2020 from <https://www.amazon.in/TANTRA-Bottle-Tumbler-Suction-Non-Spill/dp/B06X9LQ8YS>, 2 Pages.

Revolutionparts, "Bmw Roundel Travel Mug—24 Oz", Product Information, retrieved on Feb. 7, 2020 from <https://www.getbmwparts.com>

(56)

References Cited

OTHER PUBLICATIONS

com/oem-parts/bmw-bmw-roundel-travel-mug-24-oz-80902475194?c=bD0zMSZuPUNhdGVnb3J5IFBhZ2U%3D, 2 Pages.

Bebetter Life, “Bebetter Yeti Lid With Slider Closure for Yeti Ozark Boss Rambler Tumbler”, Product Information, retrieved on Feb. 7, 2020 from <https://www.amazon.in/Bebetter-Slider-Closure-Rambler-Tumbler/dp/B01MU8QERZ>, 1 Page.

Shopee, “Splash Spill Proof Lid for 20 30 Oz Ozark Trail Rtic Yeti Rambler Tumbler Cup”, Product Information, retrieved on Feb. 7, 2020 from https://www.alibaba.com/product-detail/16oz-Sublimation-plastic-travel-mug-with_60761334059.html, 2 Pages.

Ello Products, “Elio Ogden Ceramic Travel Mug With Friction/Fit Lid”, Product Information, retrieved on Feb. 7, 2020 from https://www.amazon.com/gp/product/B01FZD7F8Q/ref=as_li_tl?ie=UTF8&tag=campingcoffee-20&camp=1789&creative=9325&linkCode=as2&creativeASIN=B01FZD7F8Q&linkId=b37492aa9fea12599c83ff1e3e4d424f, 2 Pages.

Norchill® Coolers & Drinkware, “Universal Tumbler Lids”, Product Information, retrieved on Feb. 7, 2020 from <https://norchillcoolers.com/pages/tumbler-lids>, 4 Pages.

Ubuy Co, “Yoelike 30 Oz Tumbler Double Wall Stainless Steel Vacuum Insulated Travel Mug (Bohemia, 30 Oz)” Product Information, retrieved on Feb. 7, 2020 from <https://www.a.ubuy.com.kw/en/search/index/view/product/B01GQI54PK/s/yoelike-30-oz-tumbler-double-wall-stainless-steel-vacuum-insulated-travel-mug-with-2-straws-2-splash-proof-lid-1-cleaning-brush-1-straw-cleaning-brush-bohemia-30-oz/store/store/kk/dp>, 2 Pages.

Recpro, “20Oz Tumbler Vacuum Insulated 18/8 Stainless Steel Cup W/ Slider Lid”, Product Information, retrieved on Feb. 7, 2020 from <https://www.recpro.com/20oz-tumbler-vacuum-insulated-18-8-stainless-steel-cup-w-slider-lid/>, 2 Pages.

Anhui Taicheng Paper & Plastic Technology Co., Ltd., “Promotional Cheap Plastic Diy Coffee Travel Mug With Photo Insert”, Product Information, retrieved on Nov. 13, 2019 from <https://alltableware.en.made-in-china.com/product-catalog/Plastic-Cup-Mug-1.html>, 2 Pages.

“30Oz Ice Pa Cup, Stainless Steel Vacuum Cups Car Ice Cup With Cup Cover”, Product Information, retrieved on Nov. 13, 2019 from <https://shopee.com.my/amp/30OZ-Ice-PA-Cup-Stainless-Steel-Vacuum-Cups-Car-Ice-Cup-with-Cup-Cover-i.107143912.1704046429>, 2 Pages.

Kodiak Coolers, “20Oz Kodiak Tundra Tumbler W/ 2 Lids”, Product Information, retrieved on Nov. 13, 2019 from <http://www.woodworkingparts.com/clearance-20oz-kodiak-tundra-tumbler-w-2-lids-powder-coated-stainless-free-shipping/>, 2 Pages.

Yeti Coolers, LLC., “Yeti 20 Oz. Rambler Tumbler Straw Lid”, Product Information, retrieved on Nov. 13, 2019 from <https://www.dickssportinggoods.com/p/yeti-20-ozrambler-tumbler-straw-lid-16yeturmlamblr2odr/16yeturmlrtmblr2odr>, 3 Pages.

Youzi, Ltd., “Youzi 2 Pack Spill Proof and Splash Resistant Lid for Yeti Rtic Ozark Trails Tumbler Rambler Cups 30 Oz”, Product Information, retrieved on Nov. 13, 2019 from <https://www.amazon.com/Splash-Resistant-Trails-Tumbler-Rambler/dp/B075QZCS3J?tag=vehiclegps09-20>, 2 Pages.

Epoca International, “Primula 20 Oz Thermal Hot or Cold Tumbler Cup W/ Lid and Gift Box New”, Product Information, retrieved on Nov. 13, 2019 from <https://www.ebay.ca/itm/PRIMULA-20-OZ-Thermal-Hot-or-Cold-Tumbler-Cup-w-Lid-and-Gift-Box-New-Gunmetal/323779977467?hash=item4b62ca60fb:g:w3gAAOSwITZccfe3>, 2 Pages.

Dollar Tree Inc., “Customizable Photo Travel Mugs With Flip-Top Closures, 11 Oz”, Product Information, retrieved on Nov. 13, 2019 from <https://www.dollartree.com/customizable-photo-travel-mugs-with-flip-top-closures-11oz/197308>, 1 Page.

Great American Products, “Philadelphia Phillies 2Oz Acrylic/ Stainless Steel Shot Glass W/Metallic Graphics”, Product Information, retrieved on Nov. 13, 2019 from <http://www.gap1.com/store/p/39963-Philadelphia-Phillies-2oz-Acrylic/Stainless-Steel-Shot-Glass-w/Metallic-Graphics.html>, 2 Pages.

Bindle Bottle, “Bindle Bottle”, Product Information, retrieved on Jul. 17, 2020 from <https://bindlebottle.com/>, 2 Pages.

“Stainless Steel Tumbler Safe Water Bottle”, Product Information, retrieved on Jul. 17, 2020 from <https://www.aliexpress.com/i/4000166861654.html>, 1 Page.

“Advertising Paper Insert Coffee Cups, 16Oz Stainless Steel Coffee Cups With Custom Paper Insert, Double Walled Paper Coffee Cups”, Product Information, retrieved on Jul. 17, 2020 from https://www.alibaba.com/product-detail/Advertising-paper-insert-coffee-cups-16oz_62021355166.html?spm=a2700.7724857.normalList.1.5f3c519doUfCO2, 3 Pages.

Battle Mug, “Gun Rails Mugs & Cups—Battle Mug”, Product Information, retrieved on Jul. 17, 2020 from <https://battlemug.com/collections/gun-rails>, 5 Pages.

Travah, “Diversion Safe Water Bottle”, Product Information, retrieved on Jul. 17, 2020 from <https://www.amazon.com/Tumbler-Diversion-Stainless-Valuables-Insulated/dp/B07MGWB4TL>, 2 Pages.

Blender Bottle, “Blender Bottle Gold’s Gym ProStak 22 oz”, Product Information, retrieved on Jul. 17, 2020 from <https://www.amazon.com/Blender-Bottle-Golds-ProStak-Shaker/dp/B07DRPP73K>, 2 Pages.

Yongkang Yawen Cup Co., Ltd., “Plastic Acrylic Tumbler With Removable Insert Paper,Paper Changeable Plastic Coffee Cup”, Product Information, retrieved on Nov. 13, 2019 from <https://alltableware.en.made-in-china.com/product-catalog/Plastic-Cup-Mug-1.html>, 5 Pages.

Shenzhen Lampda Photoelectric Technology Co.Ltd, “Best selling energy products 2019 protein shaker bottle, drink mix bottle, storage bottle with compartment”, Product Information, retrieved on Sep. 25, 2019 from https://www.alibaba.com/product-detail/Best-selling-energy-products-2019-protein_60451381645.html?spm=a2700.7724857.main07.24.e11f161azGThMi, 8 Pages.

Contigo, “Storage Compartment Water Bottle”, Product Information, retrieved on Sep. 25, 2019 from <https://www.awesomeinventions.com/shop/storage-compartment-water-bottle/>, 5 Pages.

Deodap, “600ml Pill Box Organizer with Water Bottle Weekly Seven Compartments with Drinking Bottle”, Product Information, retrieved on Sep. 25, 2019 from <https://www.indiamart.com/proddetail/600ml-pill-box-organizer-with-water-bottle-weekly-seven-compartments-with-drinking-bottle-21300208555.html>, 3 Pages.

primelinepromos.com, “20 Oz. Shaker Fitness Bottle w/Wireless Earbuds”, Product Information, retrieved on Sep. 25, 2019 from <https://primelinepromos.com/product/20-oz-shaker-fitness-bottle-w-wireless-earbuds/>, 3 Pages.

Contigo, “Contigo Kangaroo Shake & Go Fit w/Storage Deep Blue 709ml”, Product Information, retrieved on Sep. 25, 2019 from <https://www.mightyape.co.nz/product/contigo-kangaroo-shake-go-fit-wstorage-deep-blue-709ml/27679243>, 2 Pages.

Next Bottle, “Next Bottle”, Product Information, retrieved on Sep. 25, 2019 from <http://getnextbottle.com/> 5 Pages.

Mr. Stash Cap, Mr. Stash Cap Bottle Top Storage Compartment— Fits Plastic Soda or Water Containers, Providing Secret Hidden Diversion Spot Concealed in Lid, Can Safe in Bottles, Product Information, retrieved on Nov. 11, 2019 from <https://www.amazon.com/Mr-Stash-Cap-Diversion-Compartment/dp/B076YH8QY1>, 3 Pages.

Silver Lab, “Water Bottle with Storage Case”, Product Information, retrieved on Sep. 25, 2019 from <https://www.silverlab.co/products/water-bottle-with-storage-case>, 5 Pages.

Sangfit, “Sangfit Water Bottle with Compartment for Keys, Money and Various Cards BPA free 750 ml”, Product Information, retrieved on Sep. 25, 2019 from <https://www.amazon.co.uk/Sangfit-Water-Bottle-Compartment-Variou/dp/B06Y1H5MTP>, 5 Pages.

Contigo, “Autospout® Straw Gizmo Flip”, Product Information, retrieved on Nov. 11, 2019 from <https://mycontigo.com/>, 2 Pages.

Thermos L.L.C., “Funtainer® Stainless Steel Water Bottle With Straw 12Oz”, Product Information, retrieved on Nov. 11, 2019 from <https://www.thermos.com/genuine-thermos-brand-funtainer-vacuum-insulated-stainless-steel-bottle-12oz.html>, 5 Pages.

* cited by examiner

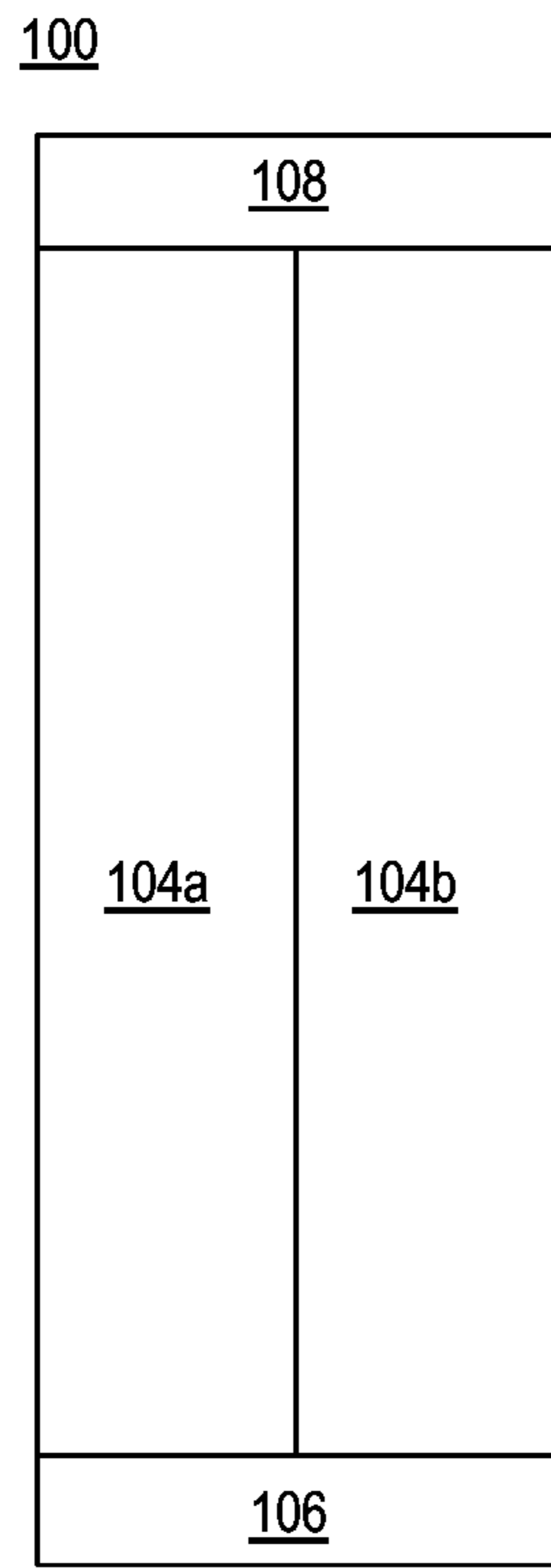

FIG. 1A

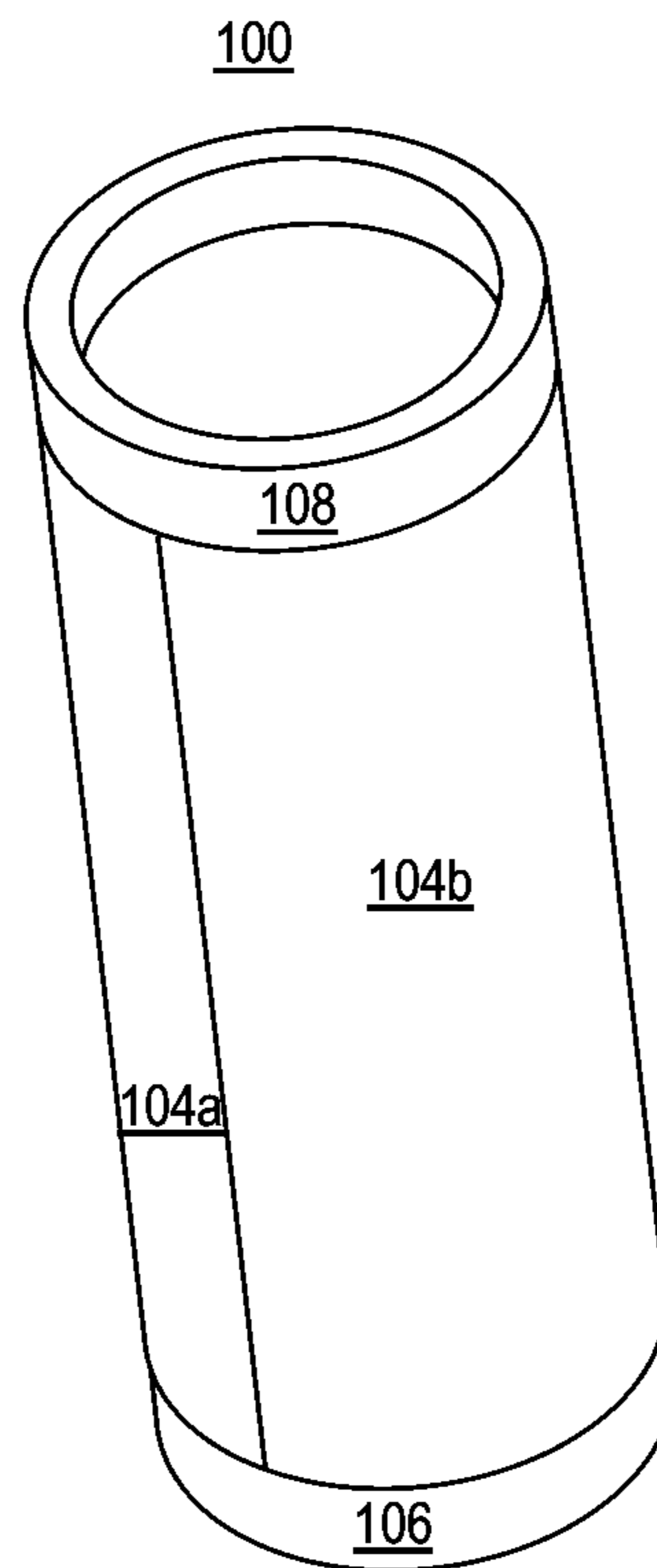

FIG. 1B

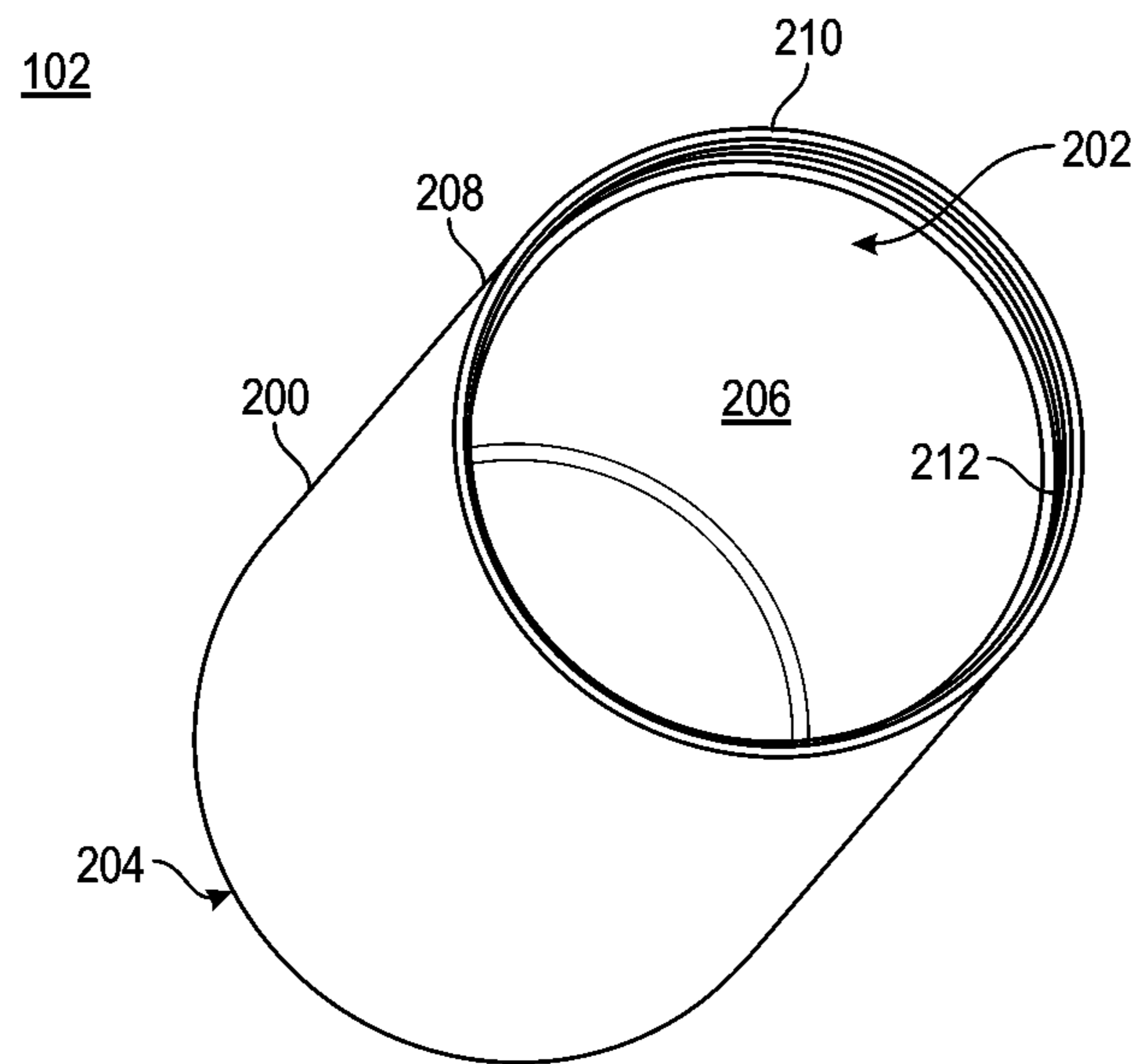

FIG. 2A

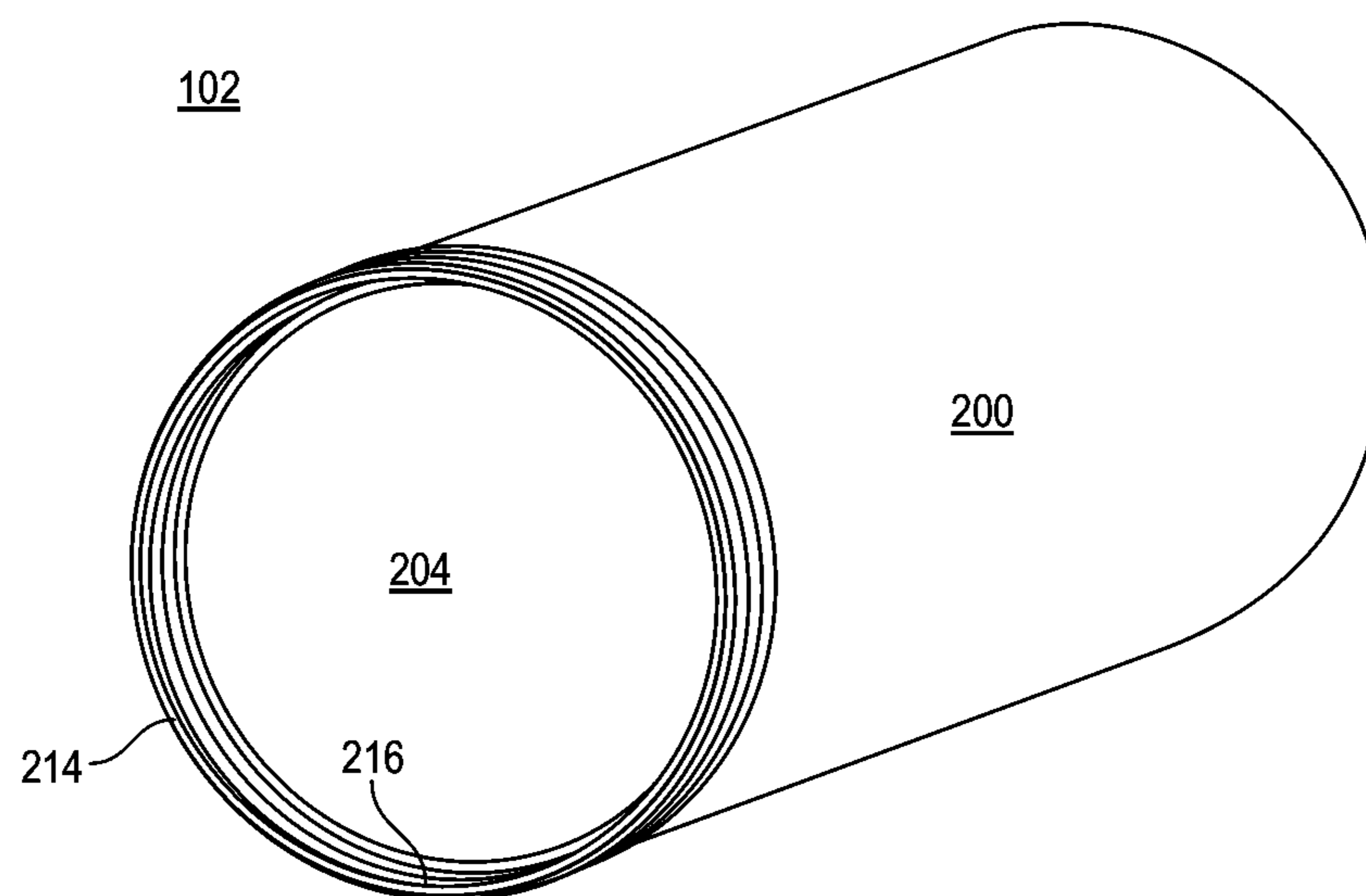

FIG. 2B

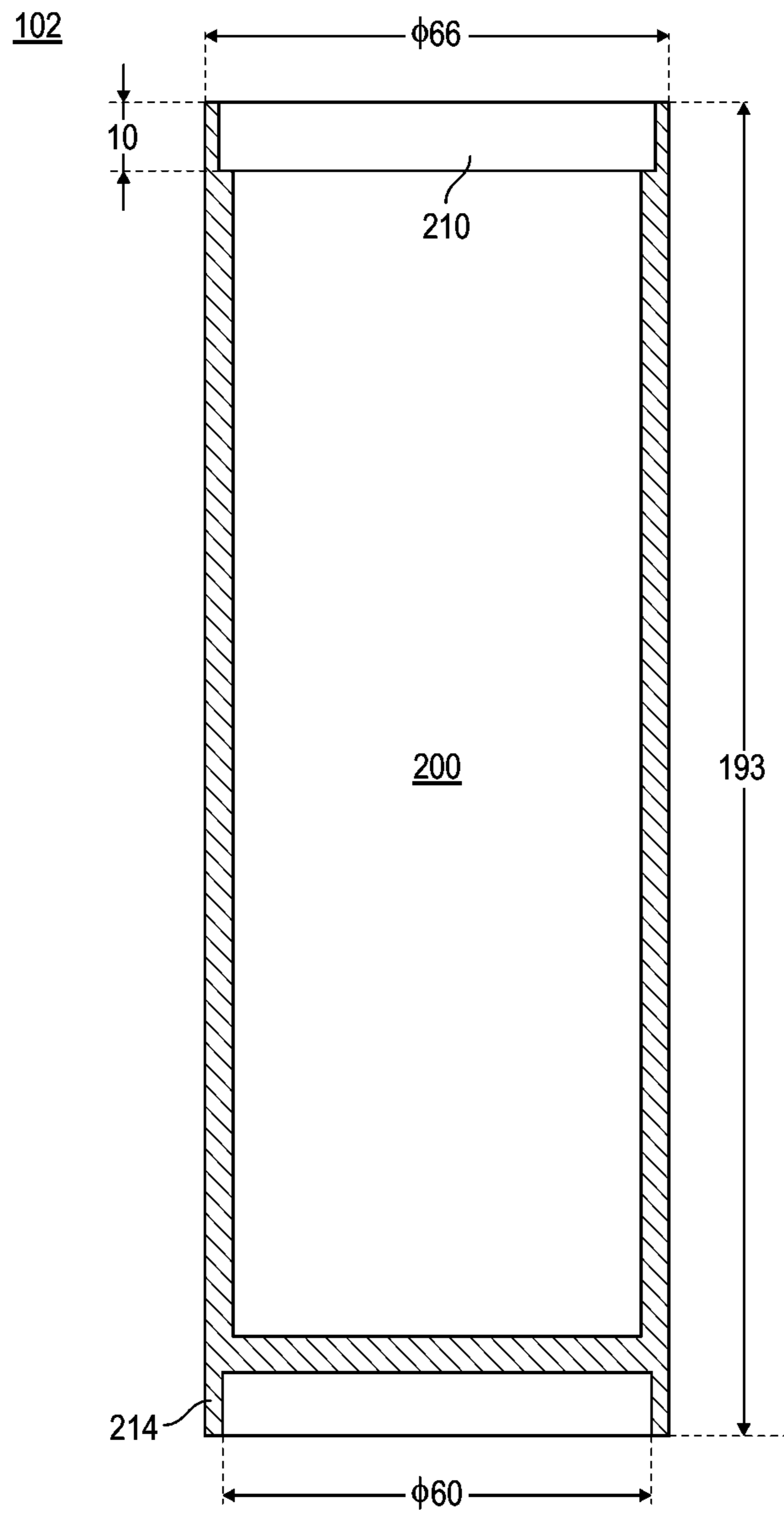

FIG. 2C

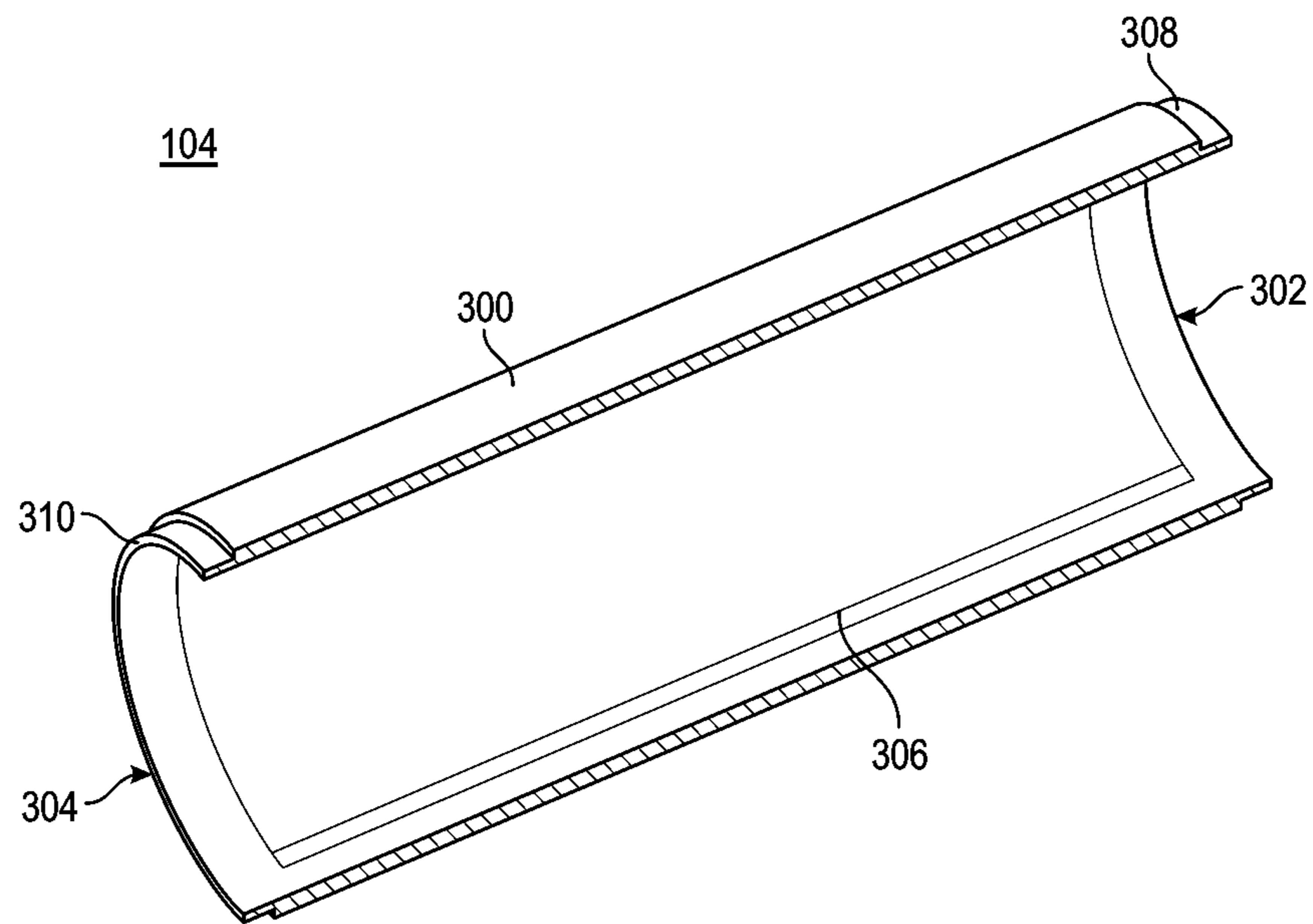

FIG. 3A

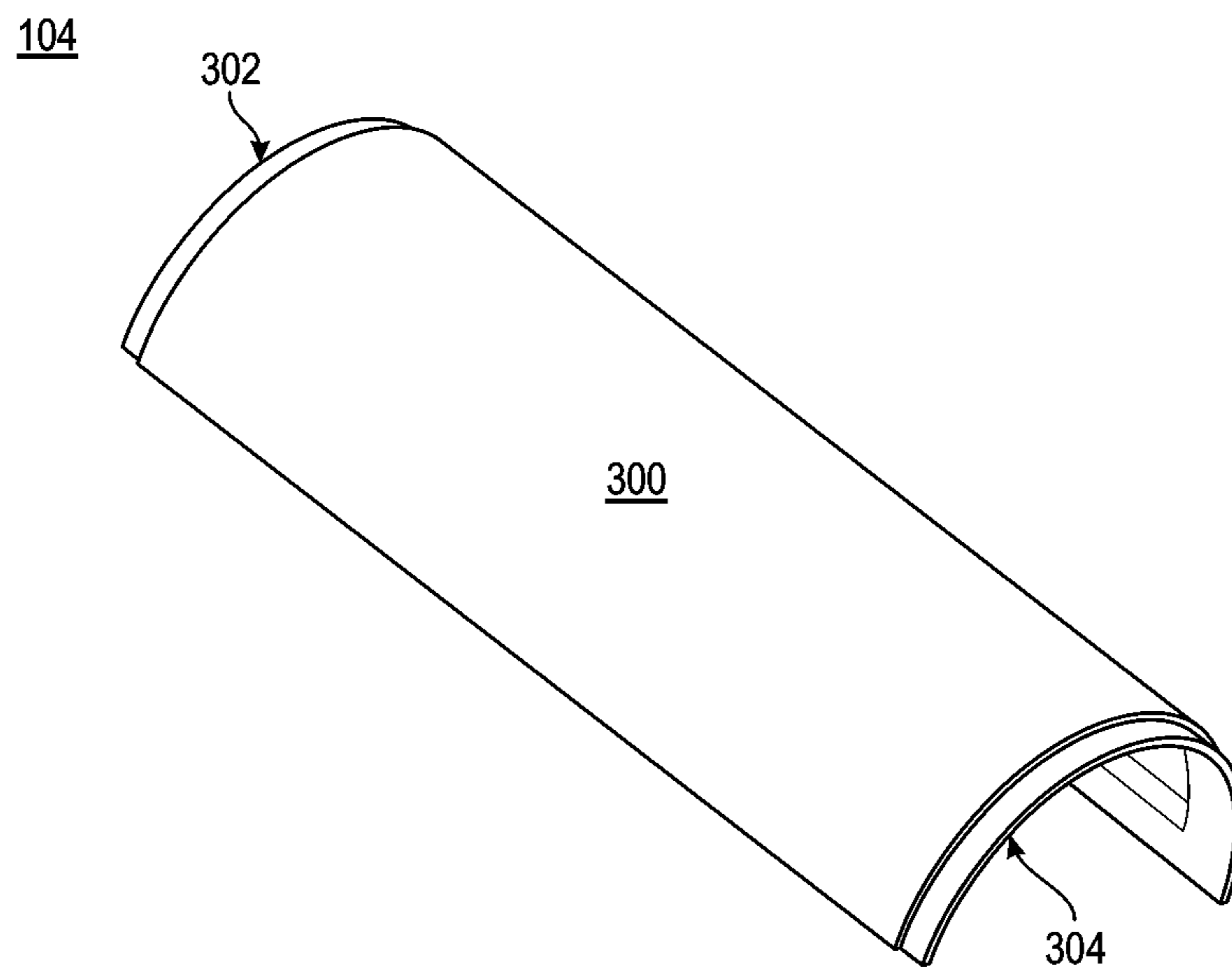

FIG. 3B

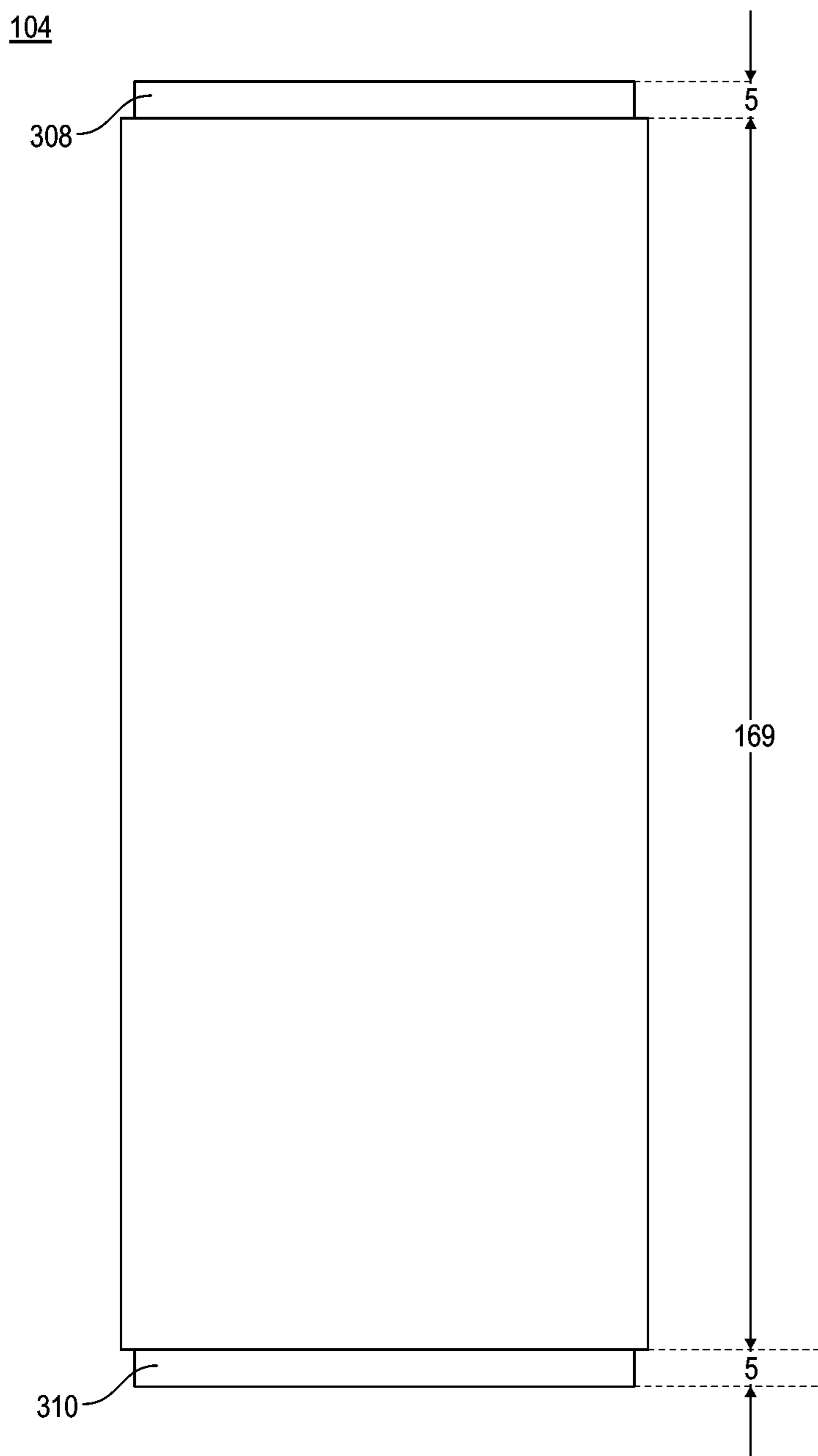

FIG. 3C

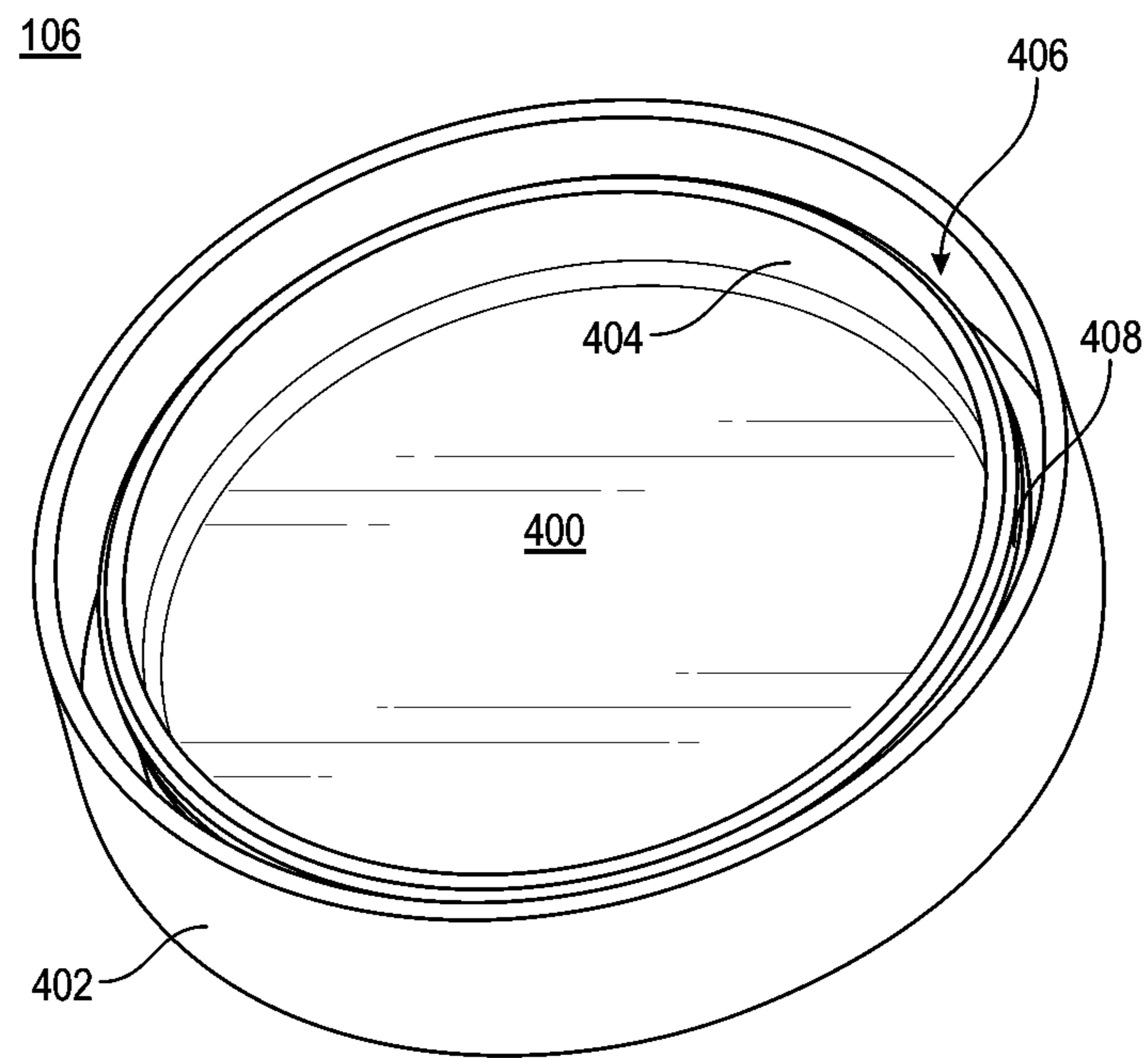

FIG. 4A

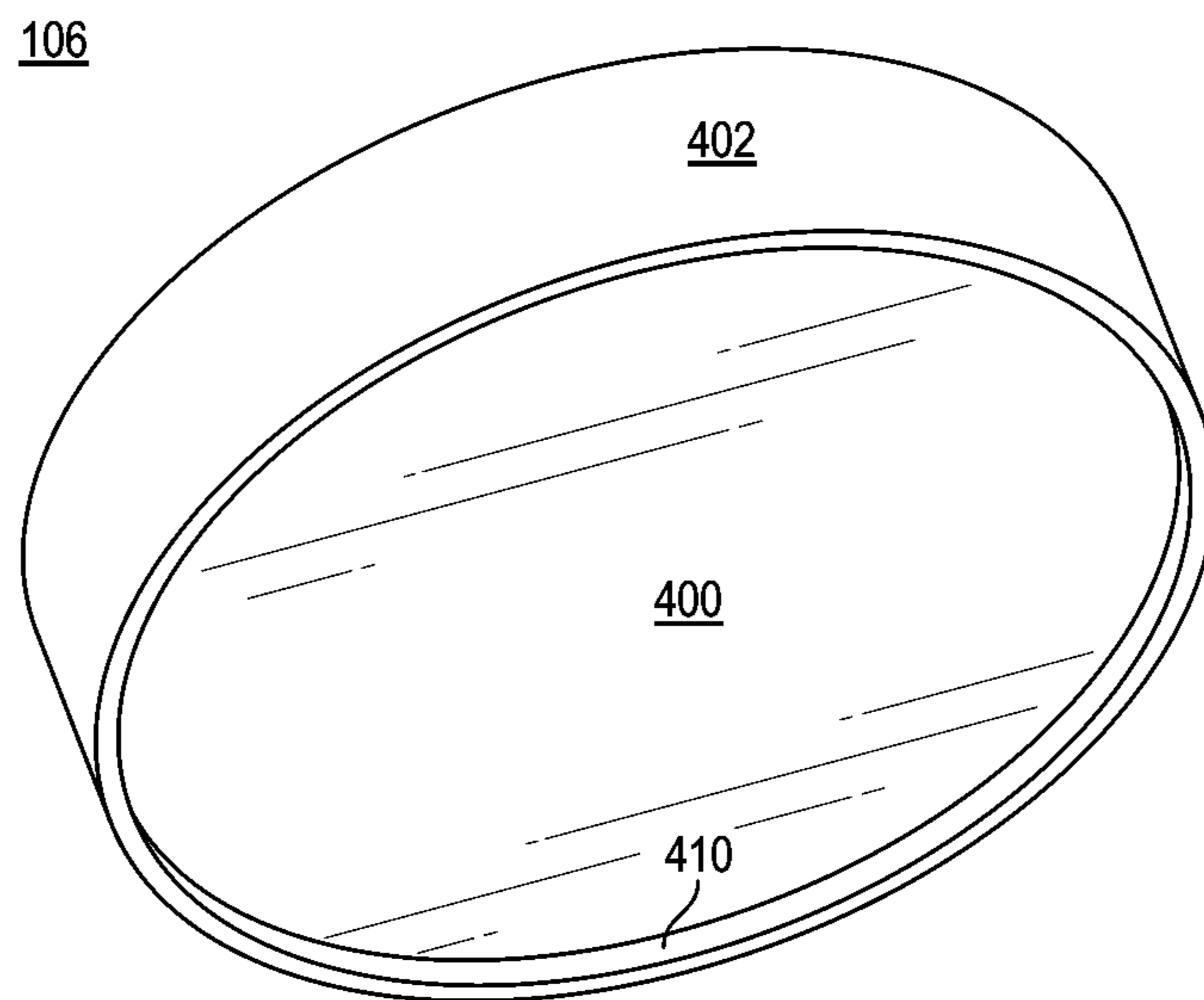

FIG. 4B

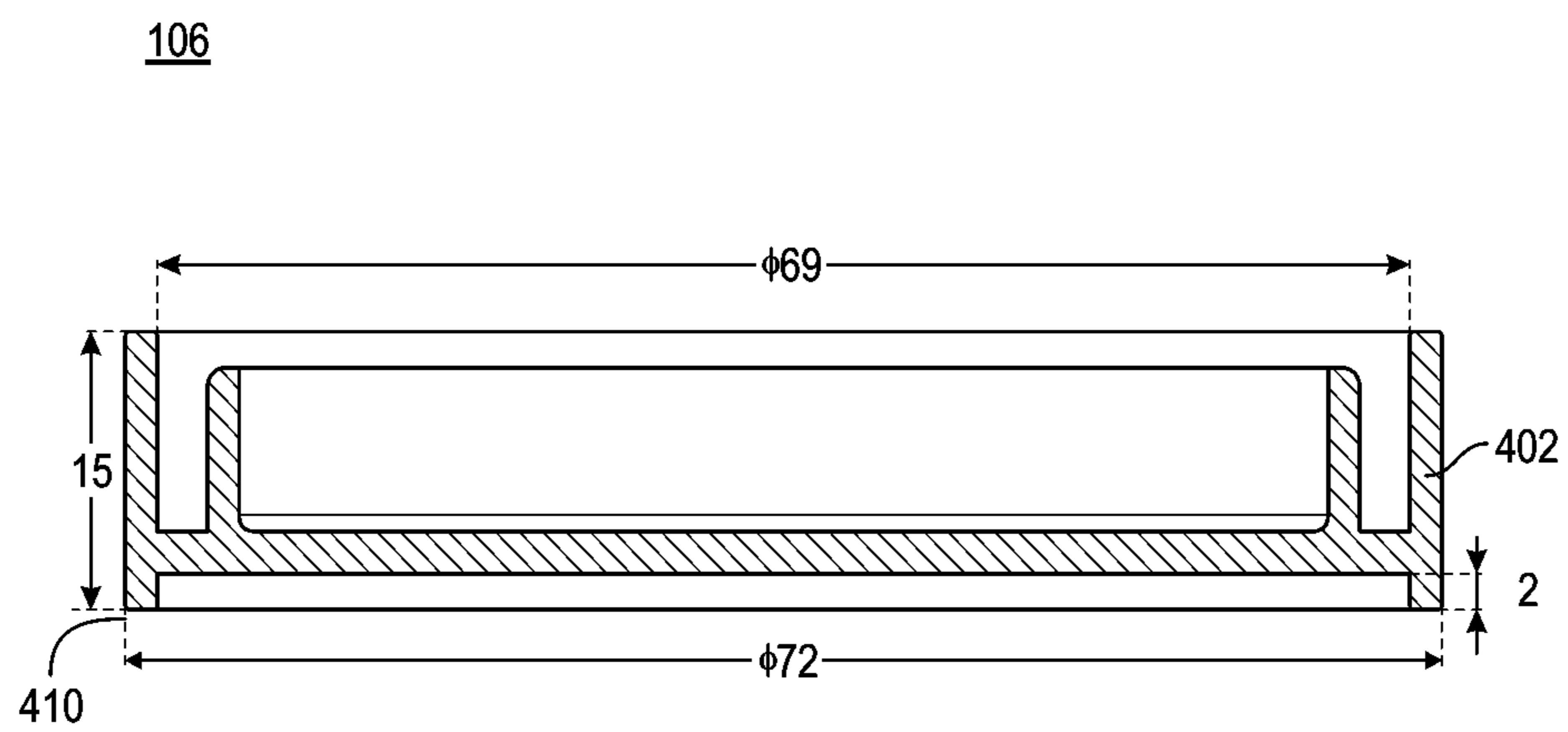

FIG. 4C

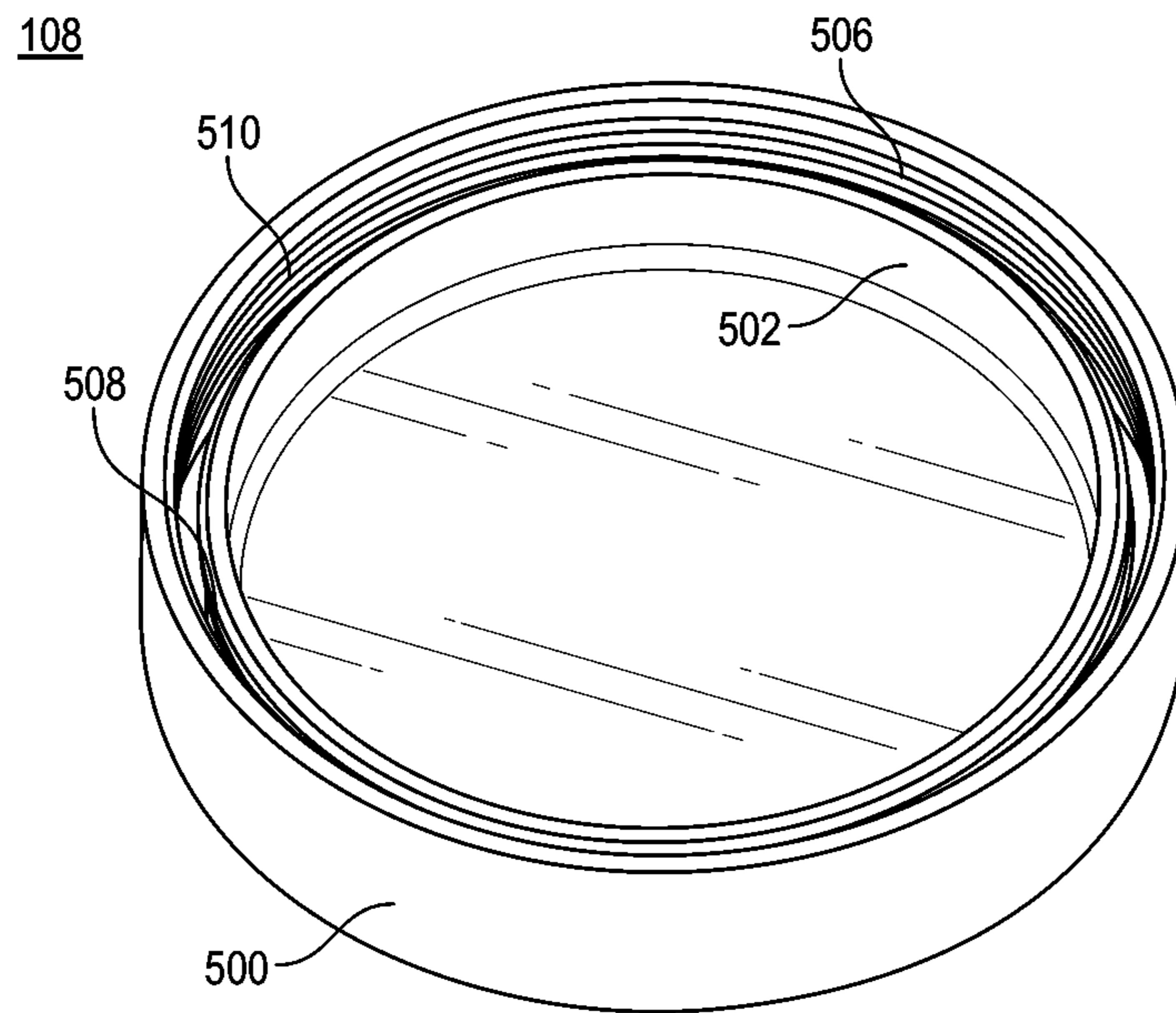

FIG. 5A

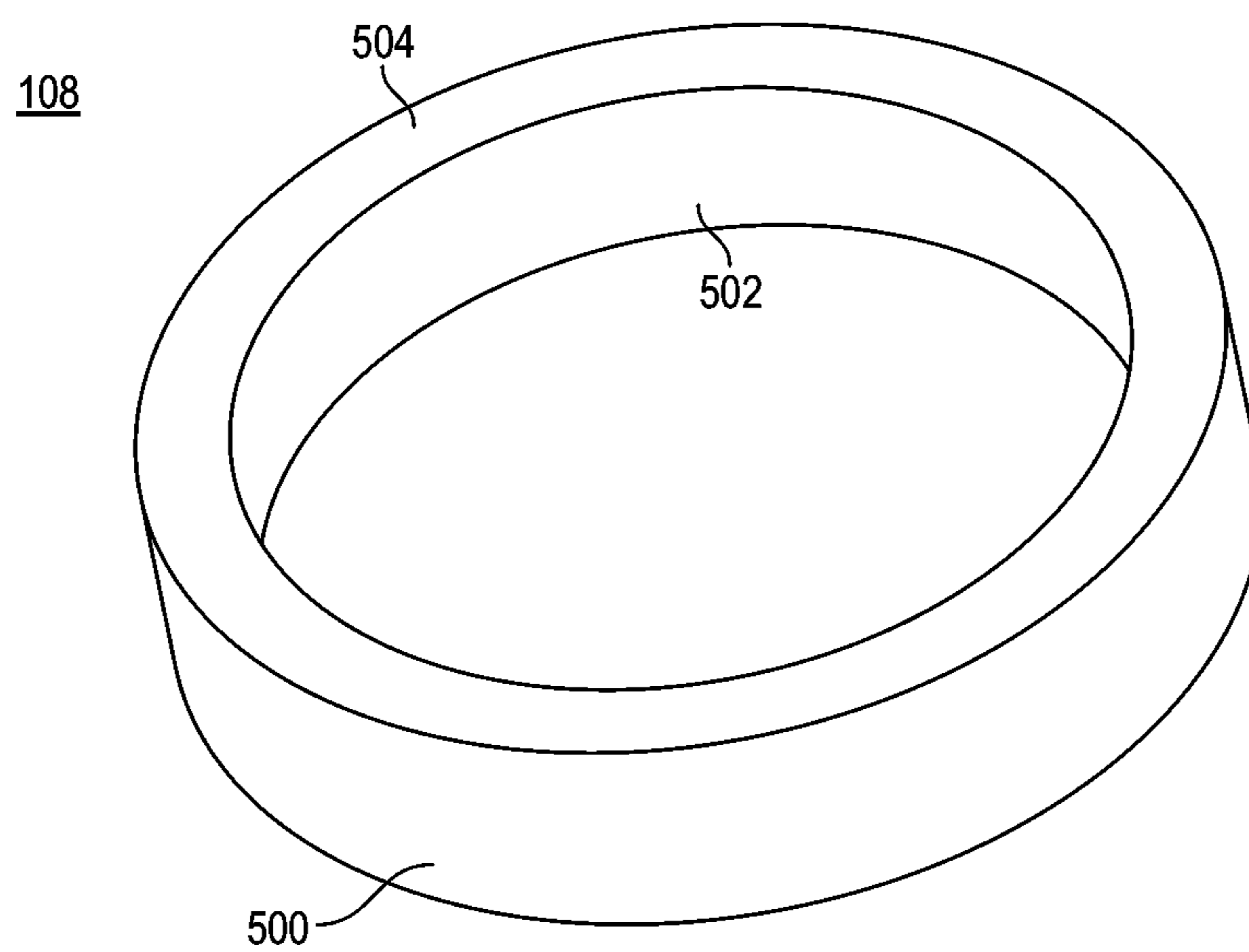

FIG. 5B

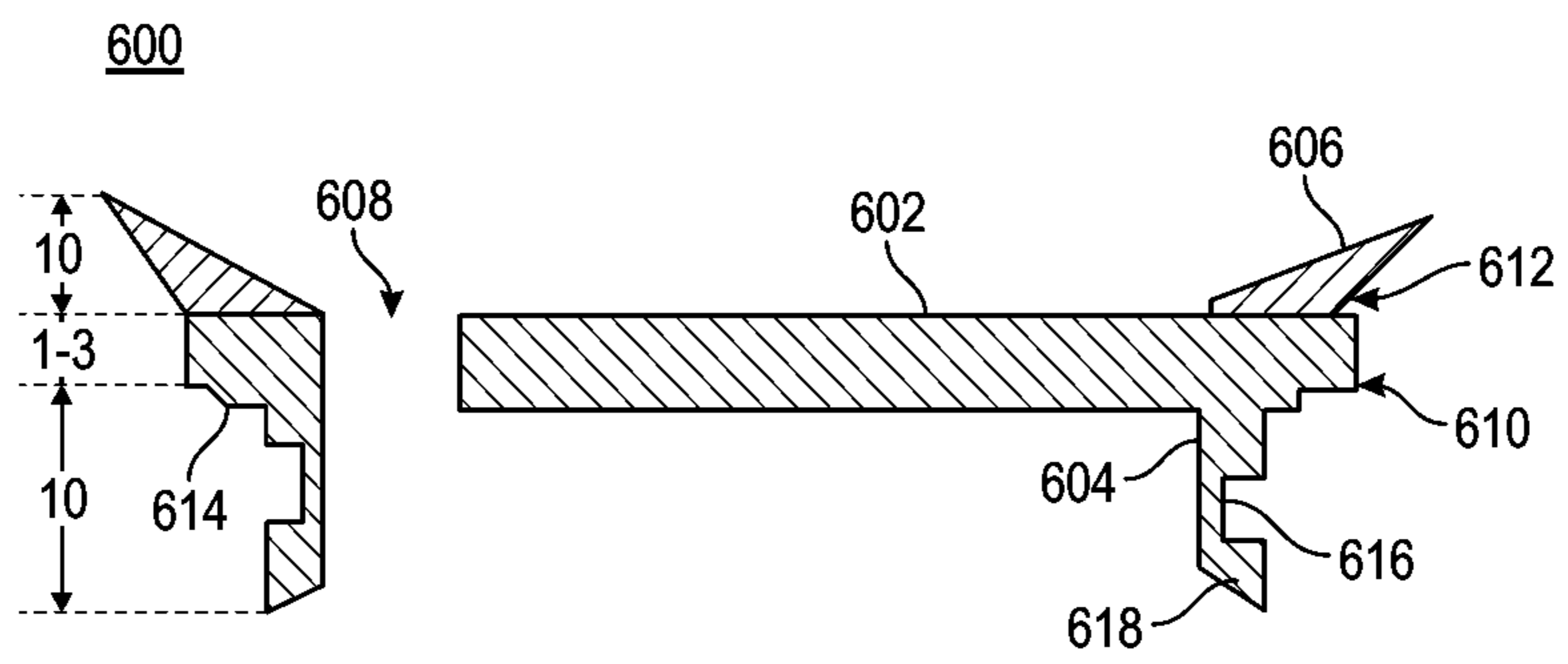
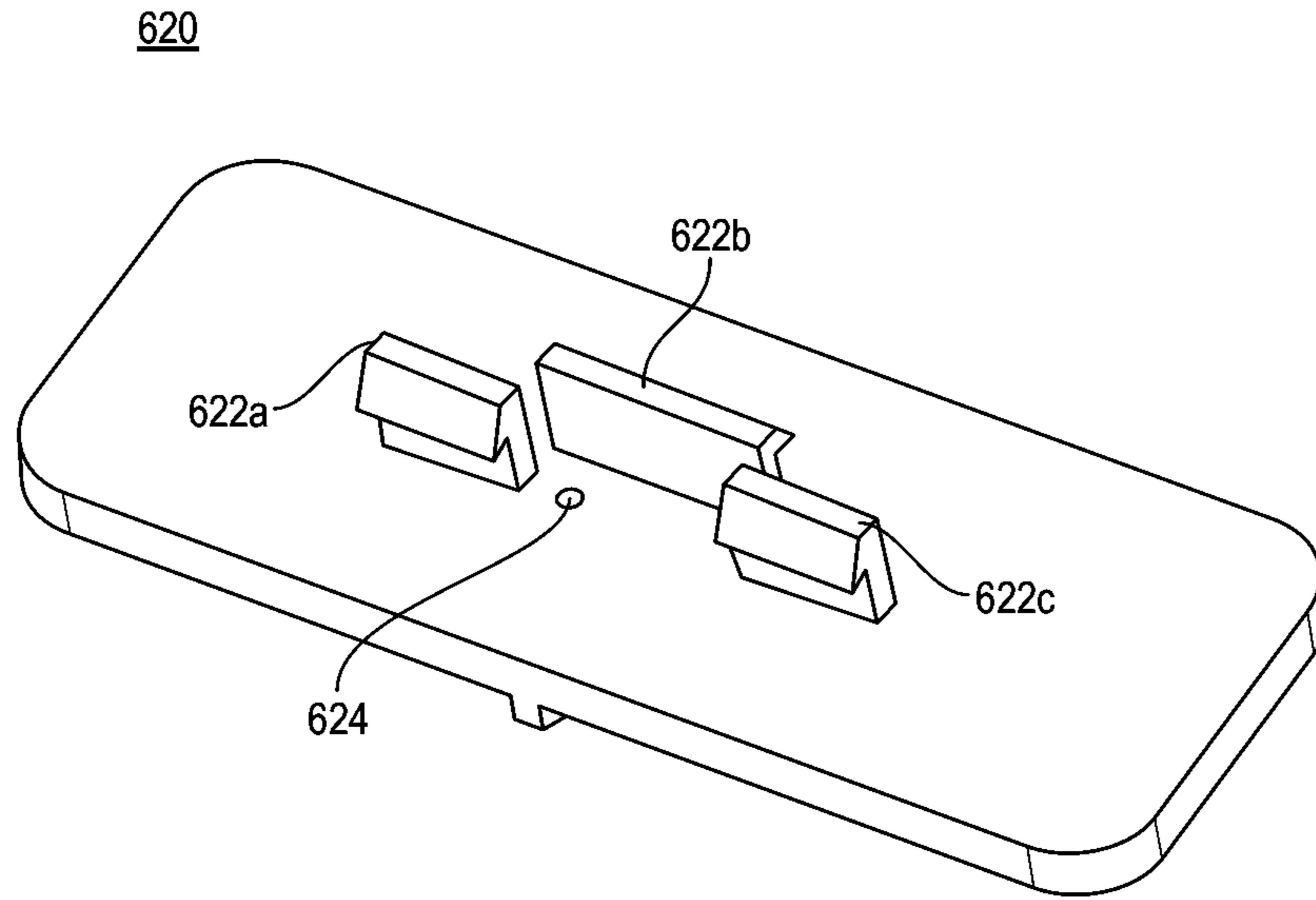

FIG. 6A



620

FIG. 6B

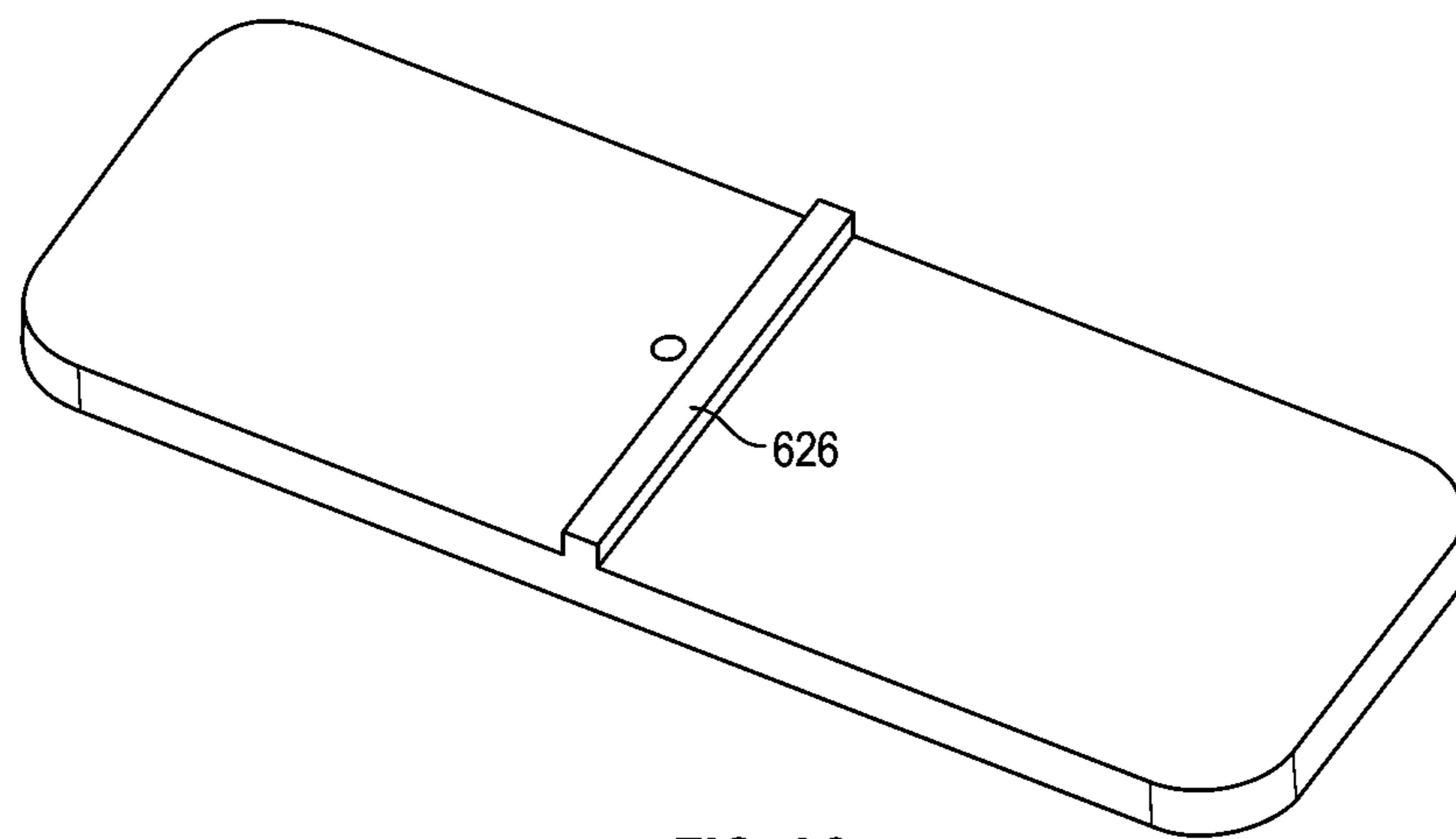

FIG. 6C



FIG. 7

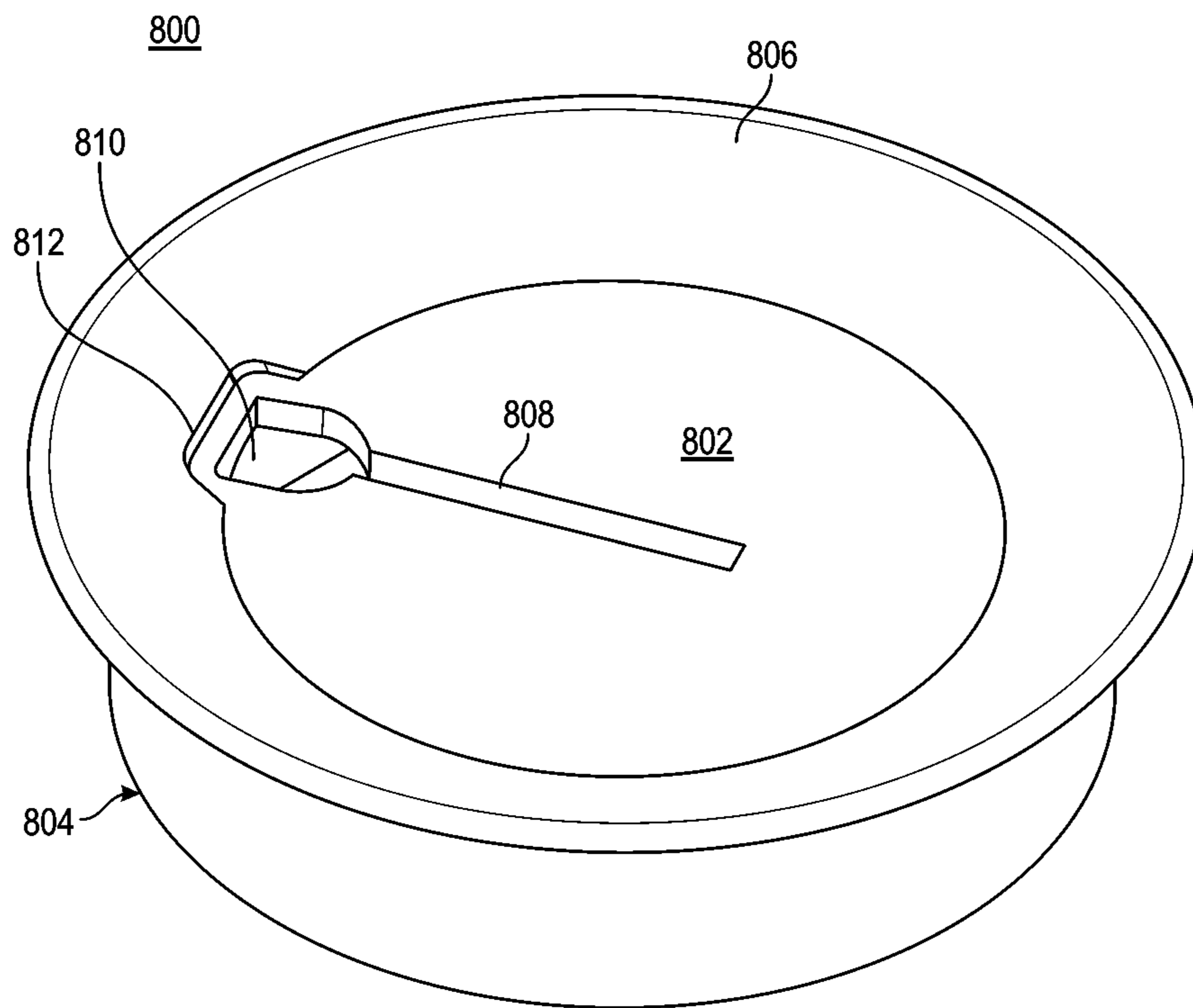

FIG. 8A

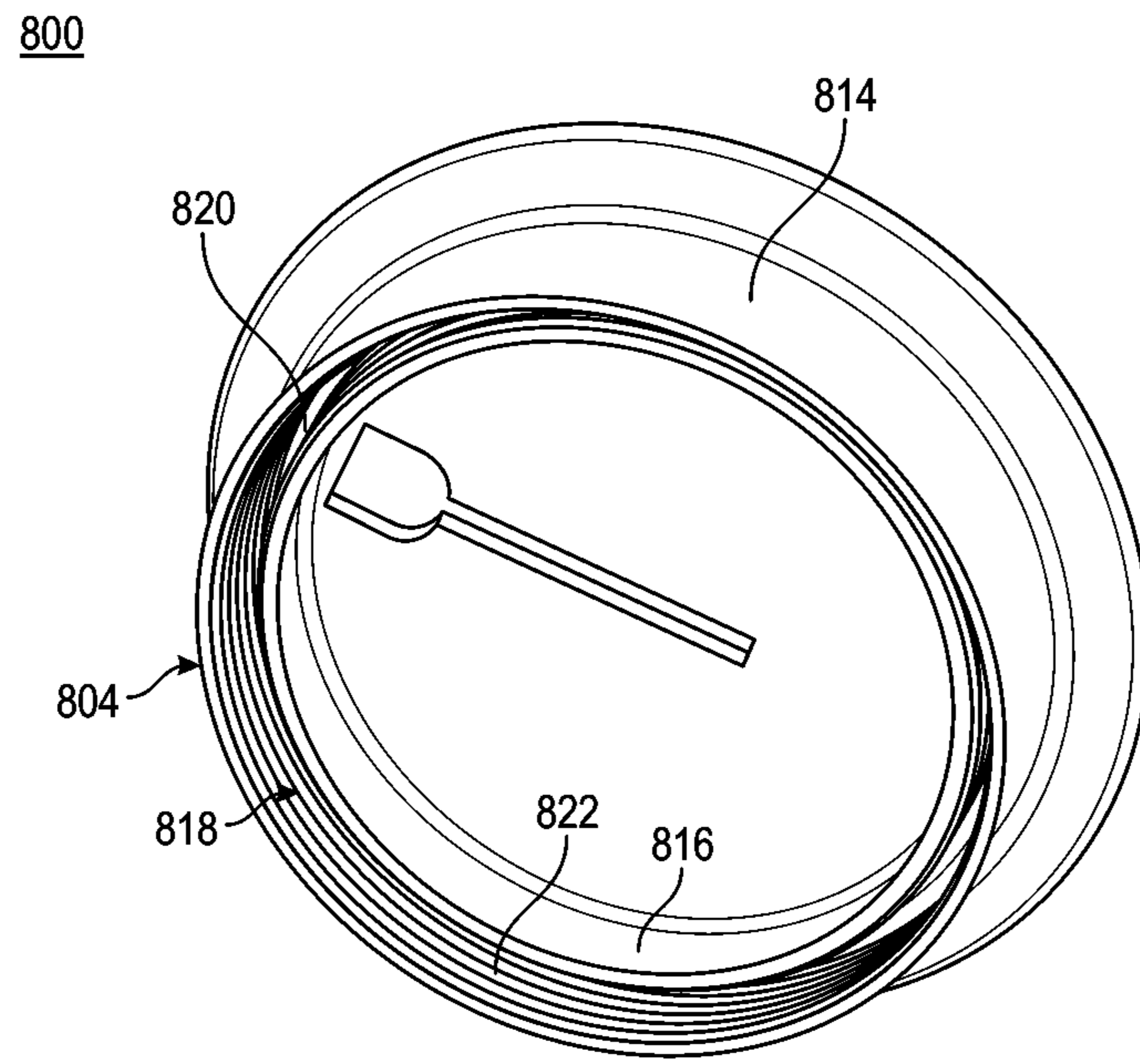

FIG. 8B

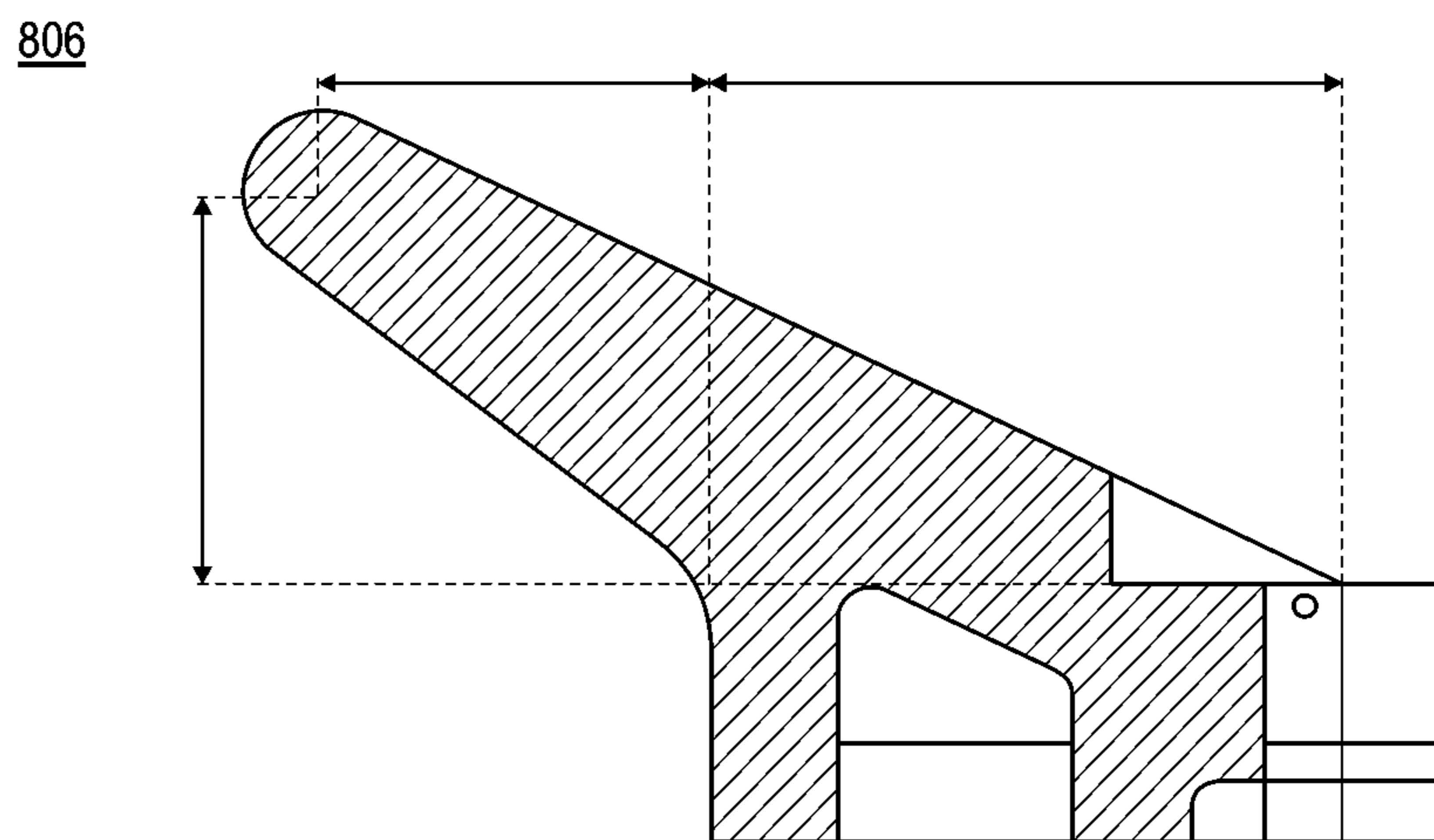

FIG. 8C

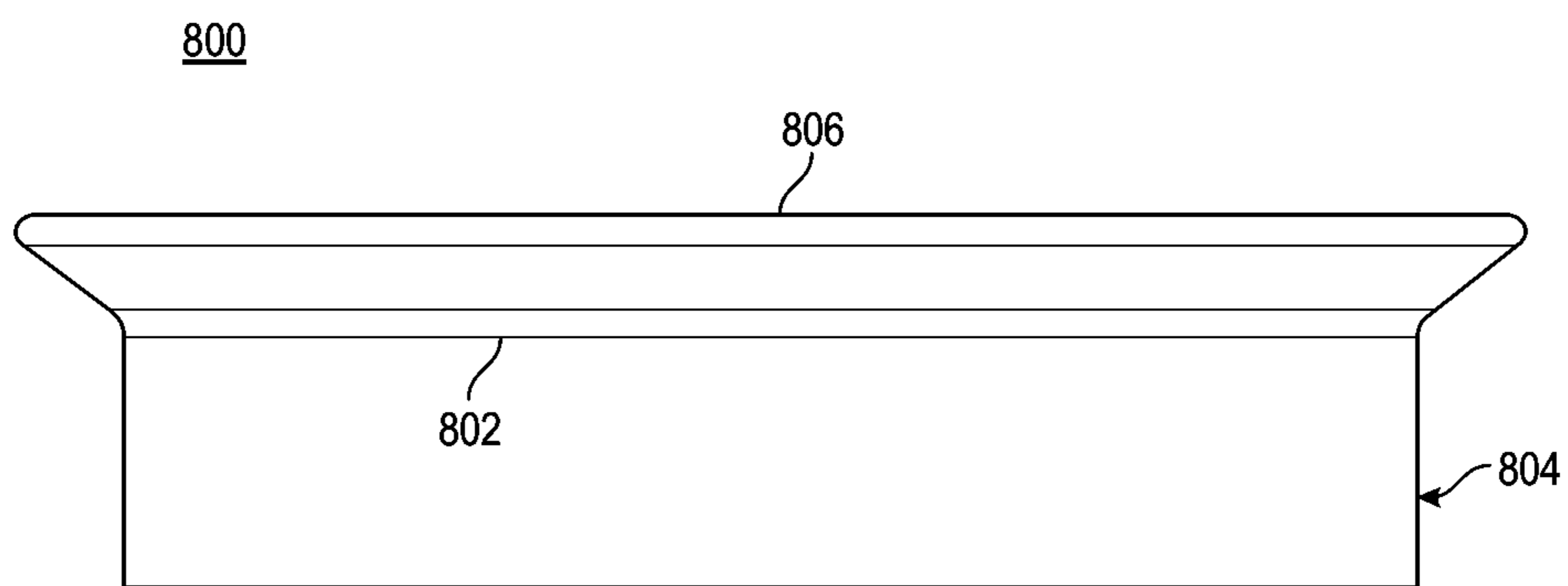

FIG. 8D

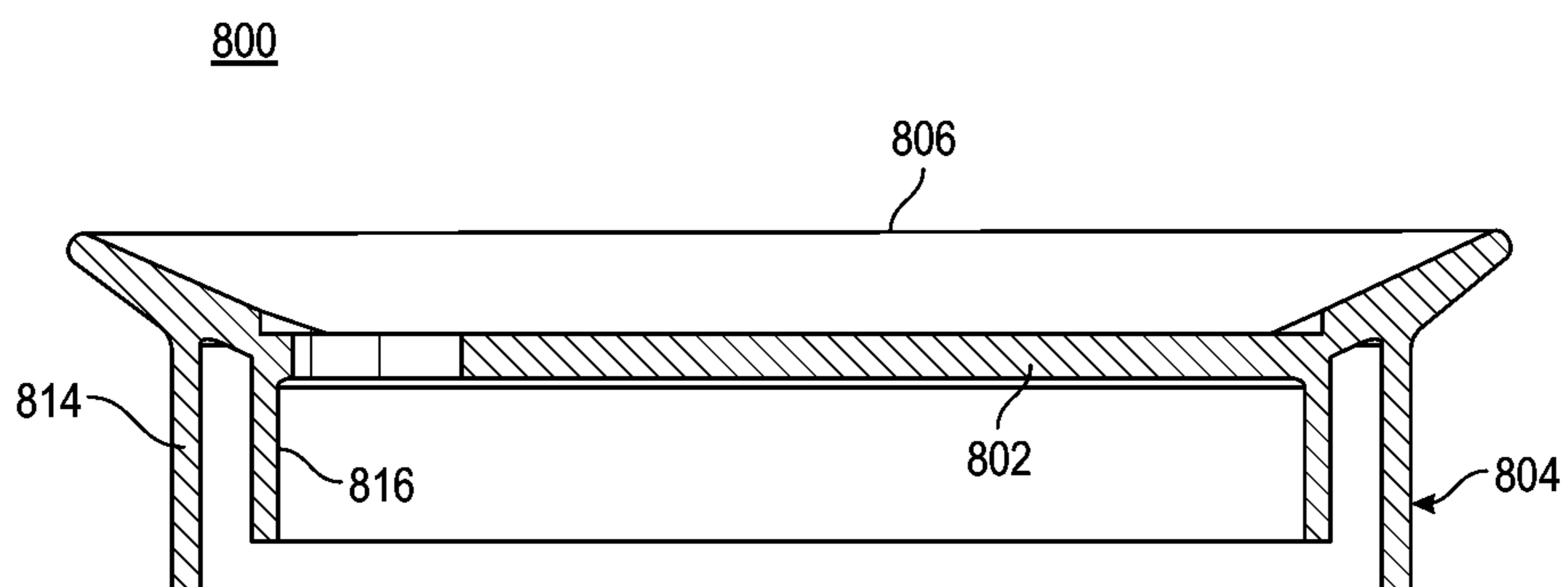

FIG. 8E

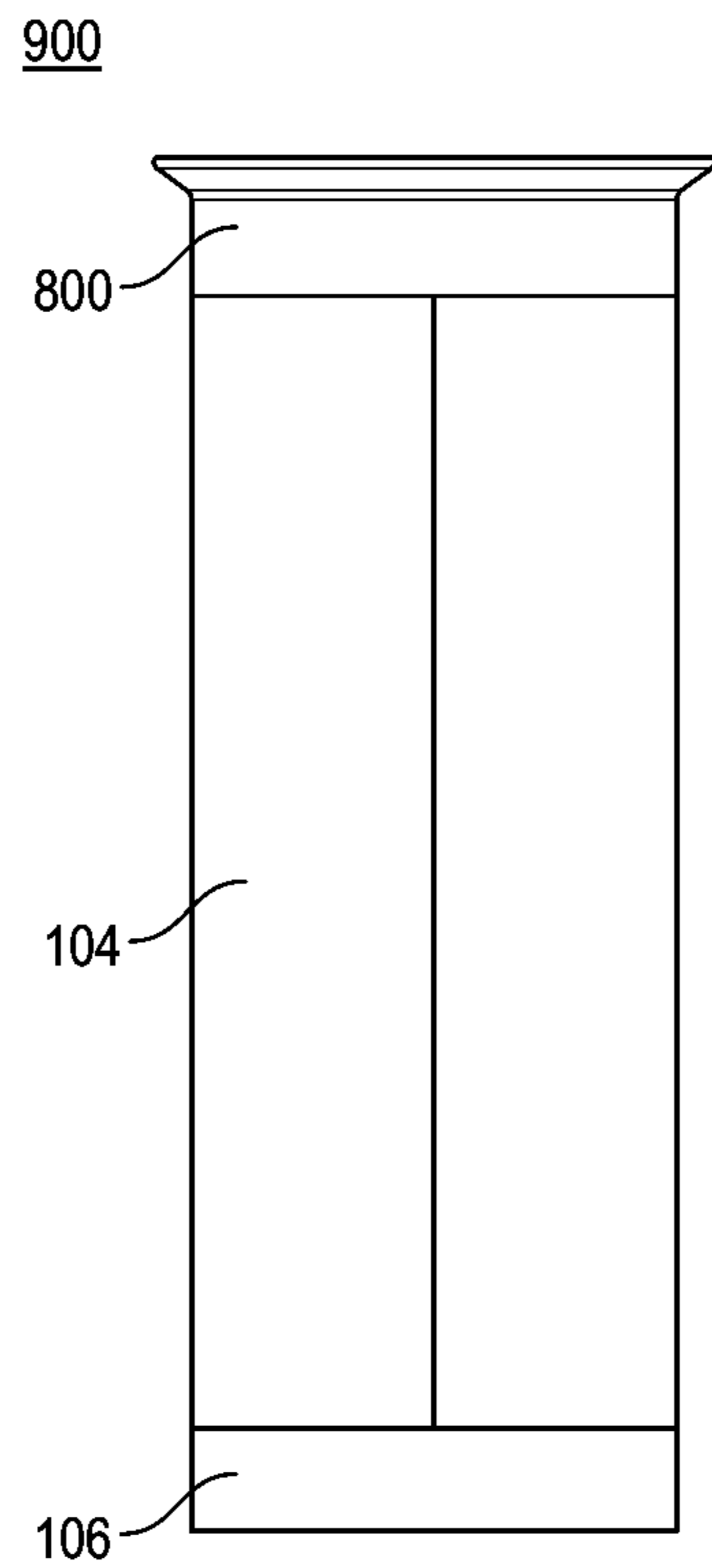

FIG. 9A

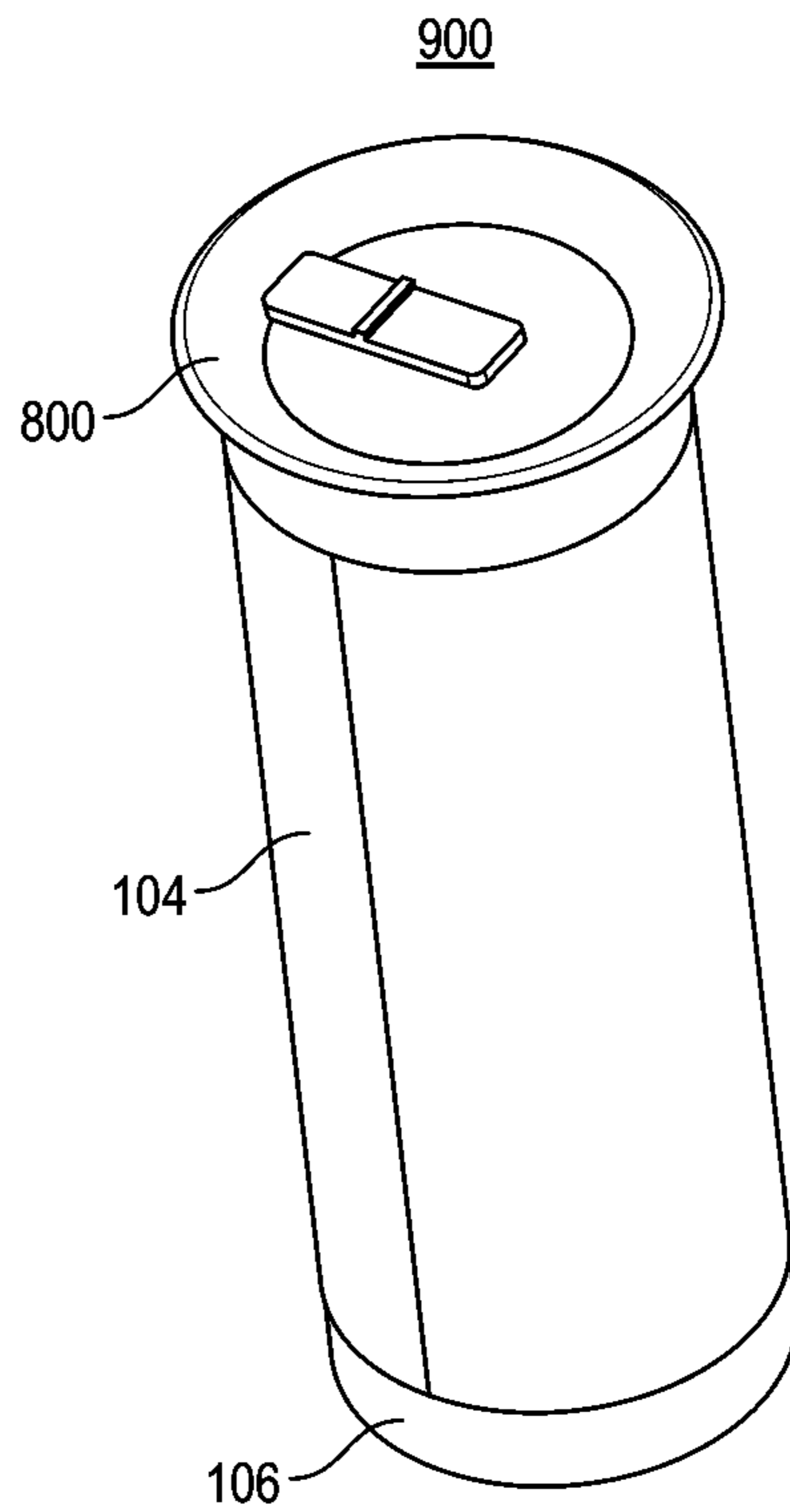

FIG. 9B

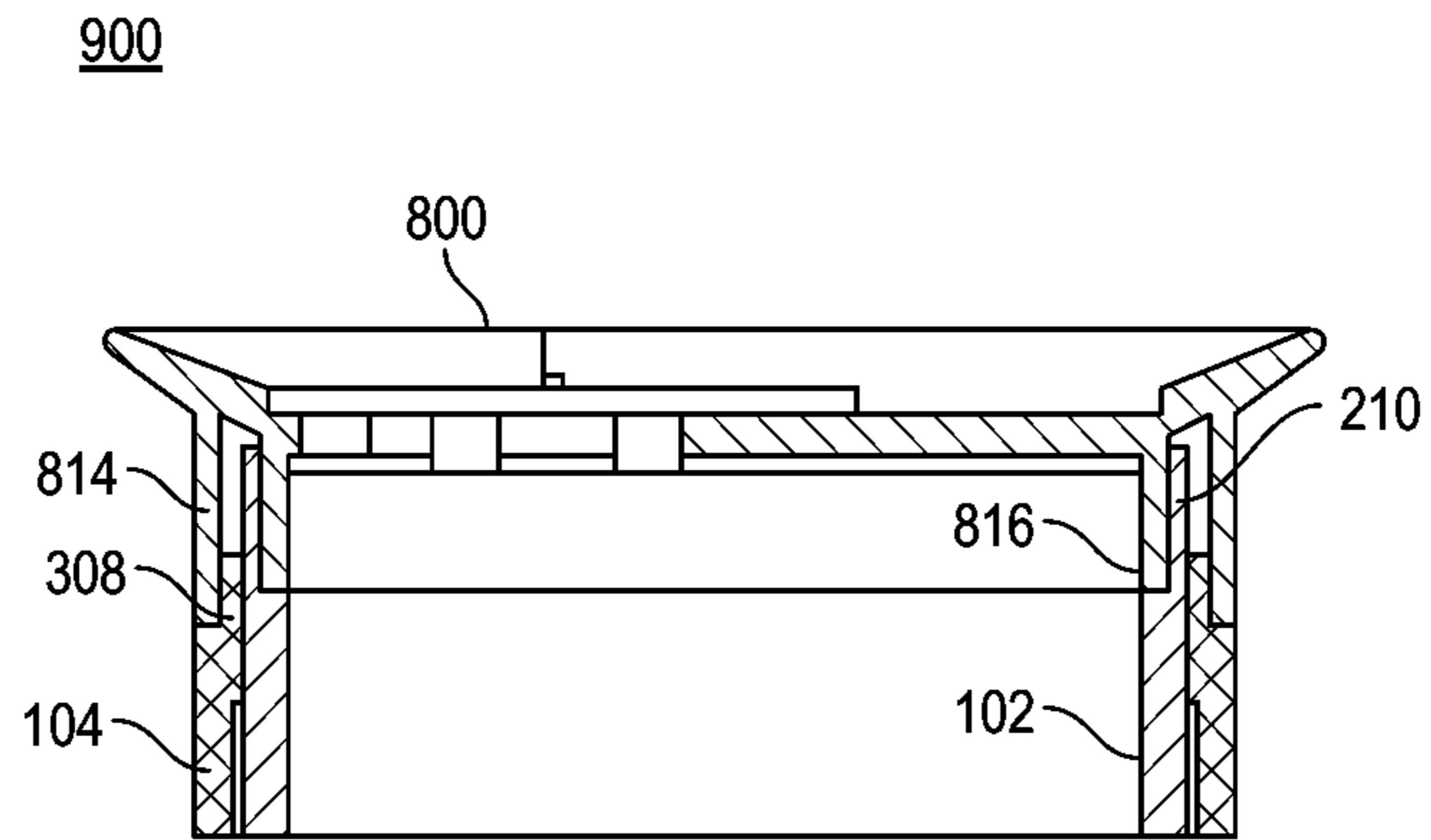

FIG. 9C

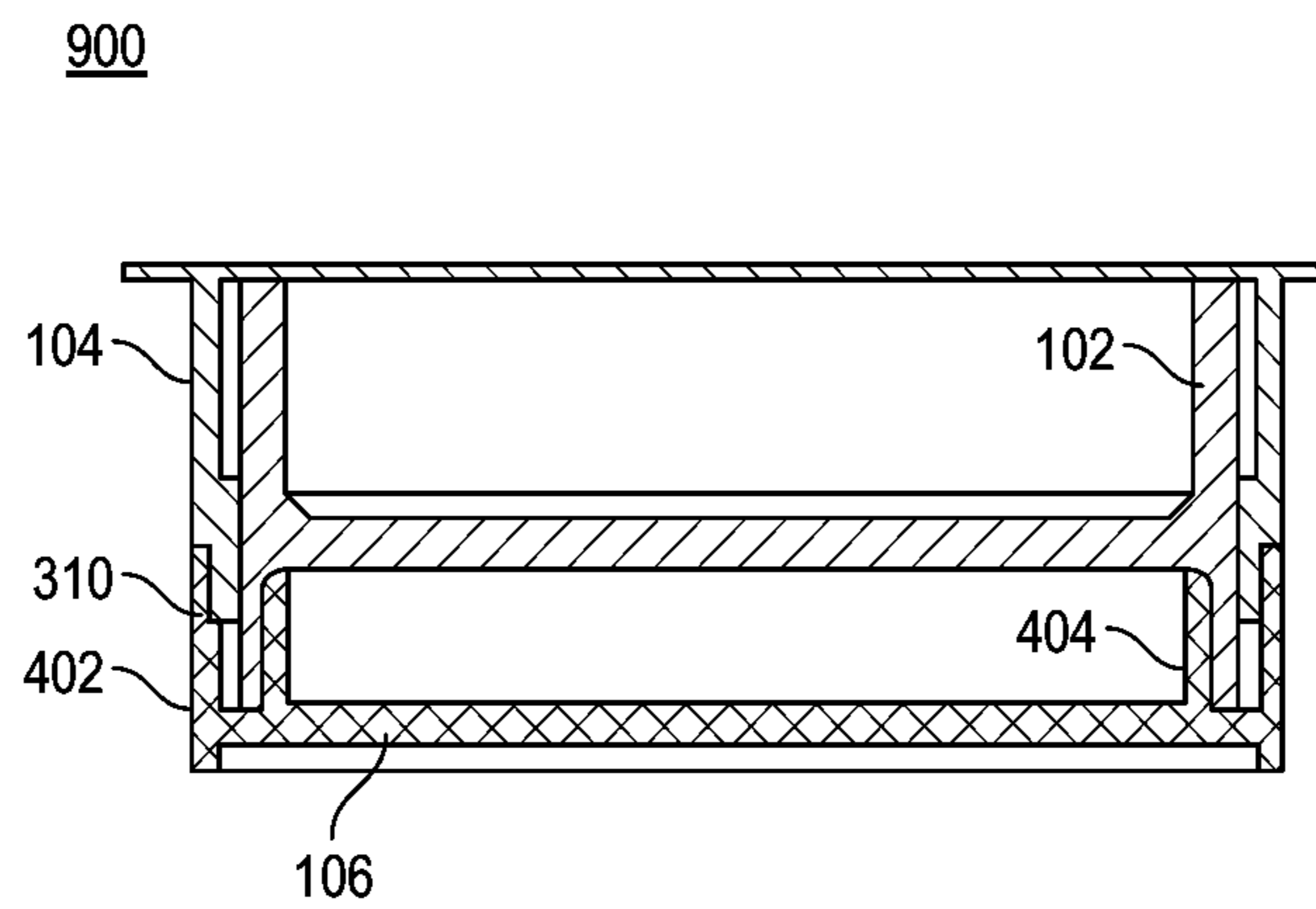

FIG. 9D

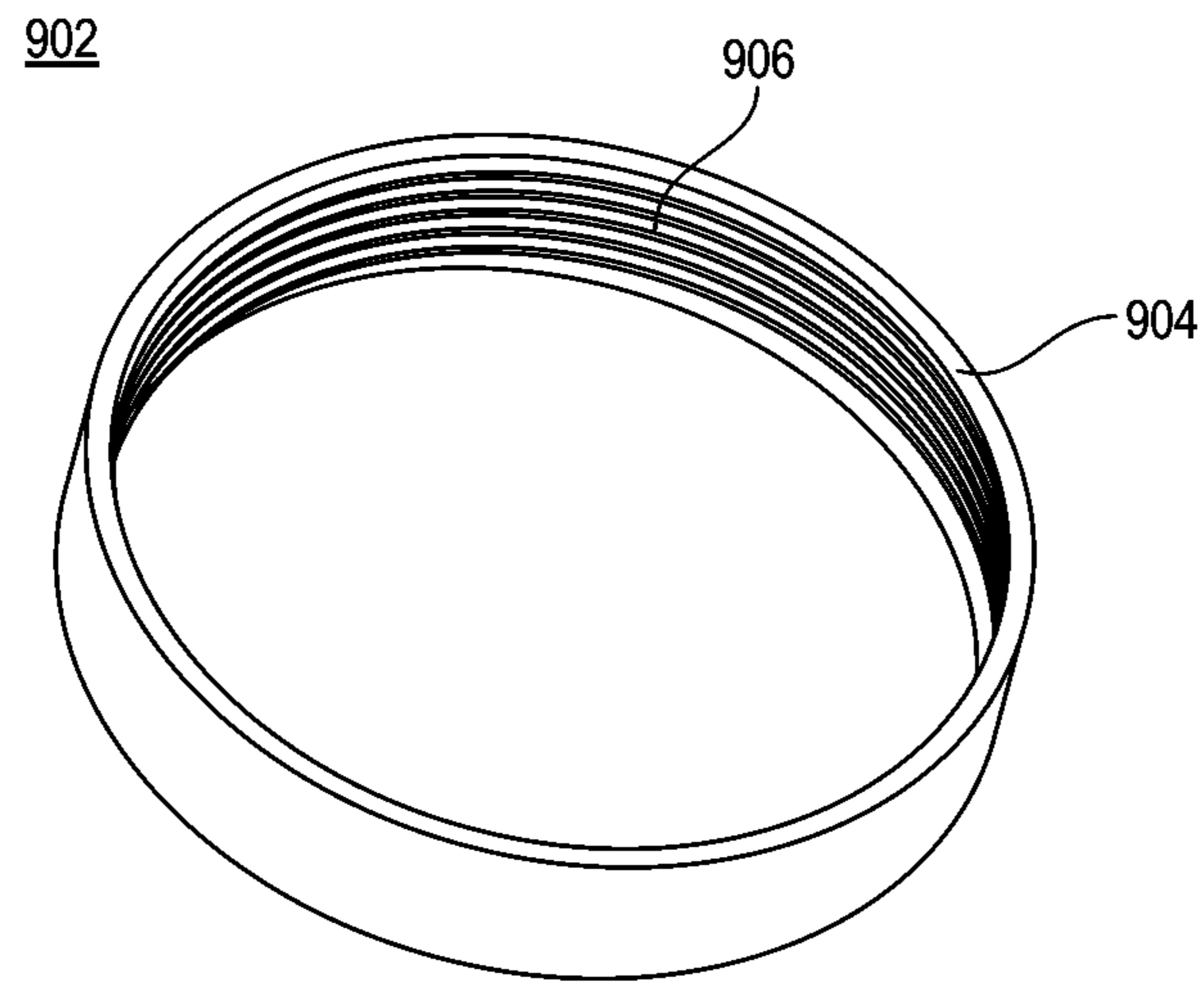

FIG. 9E

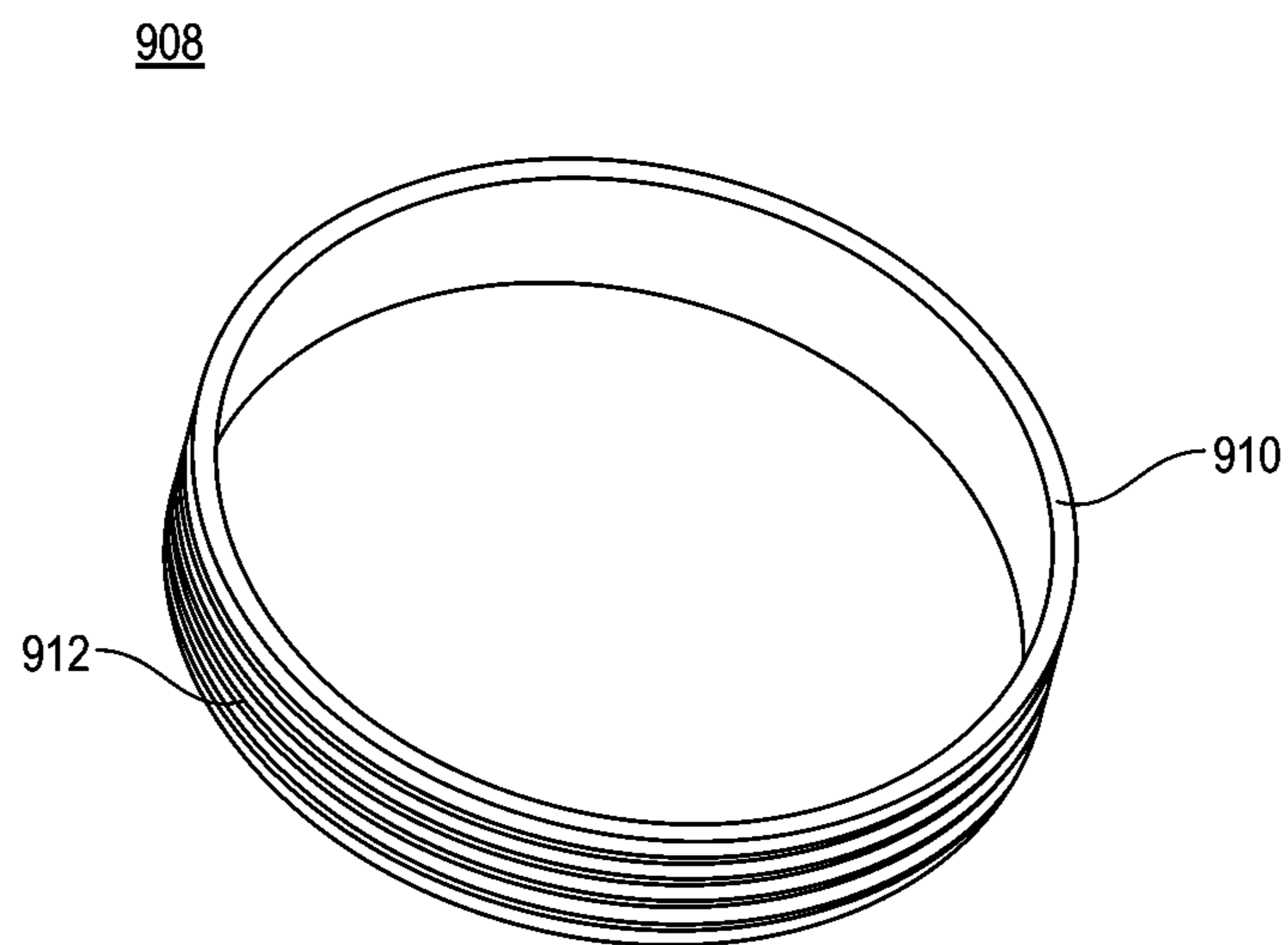

FIG. 9F

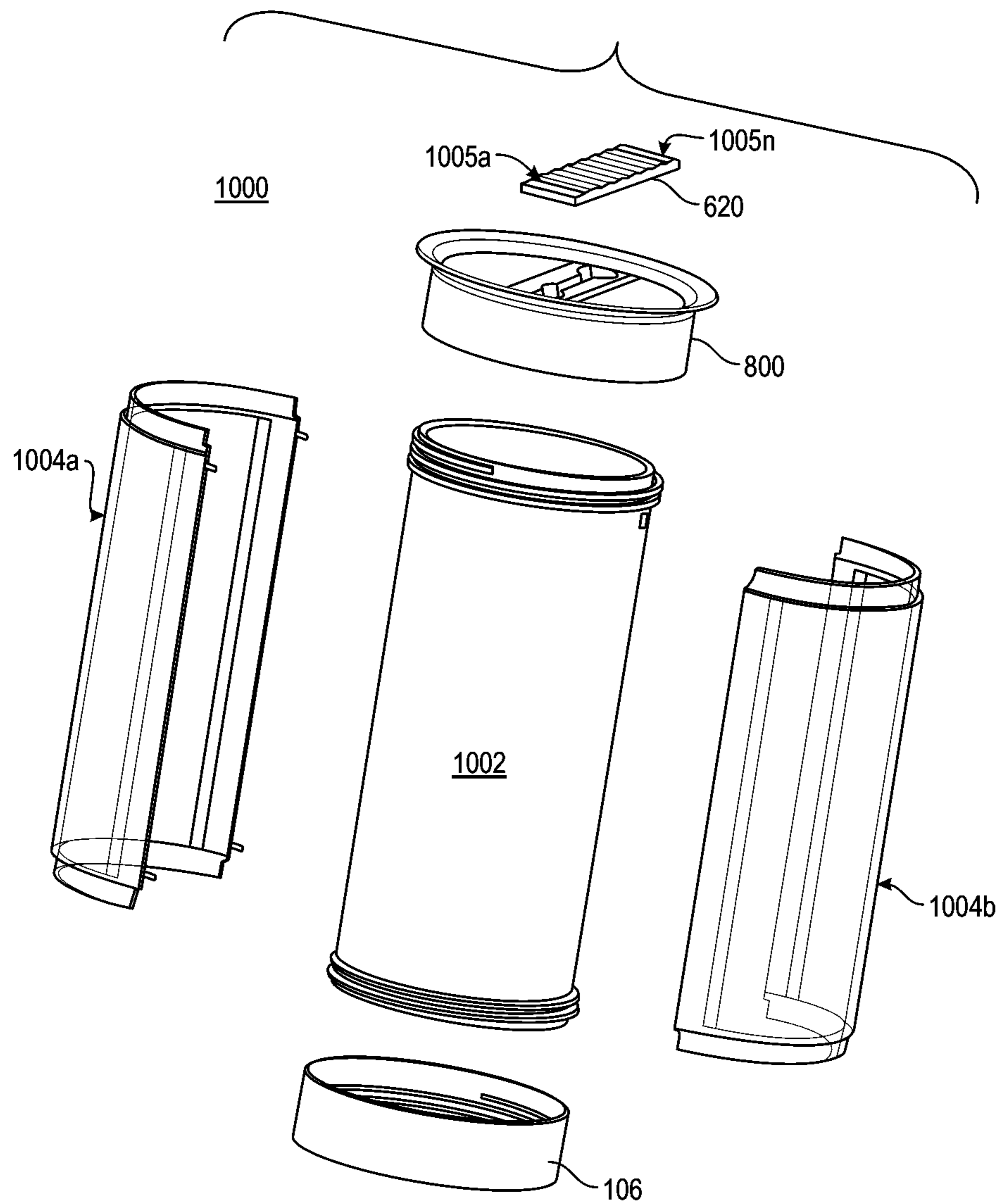

FIG. 10A

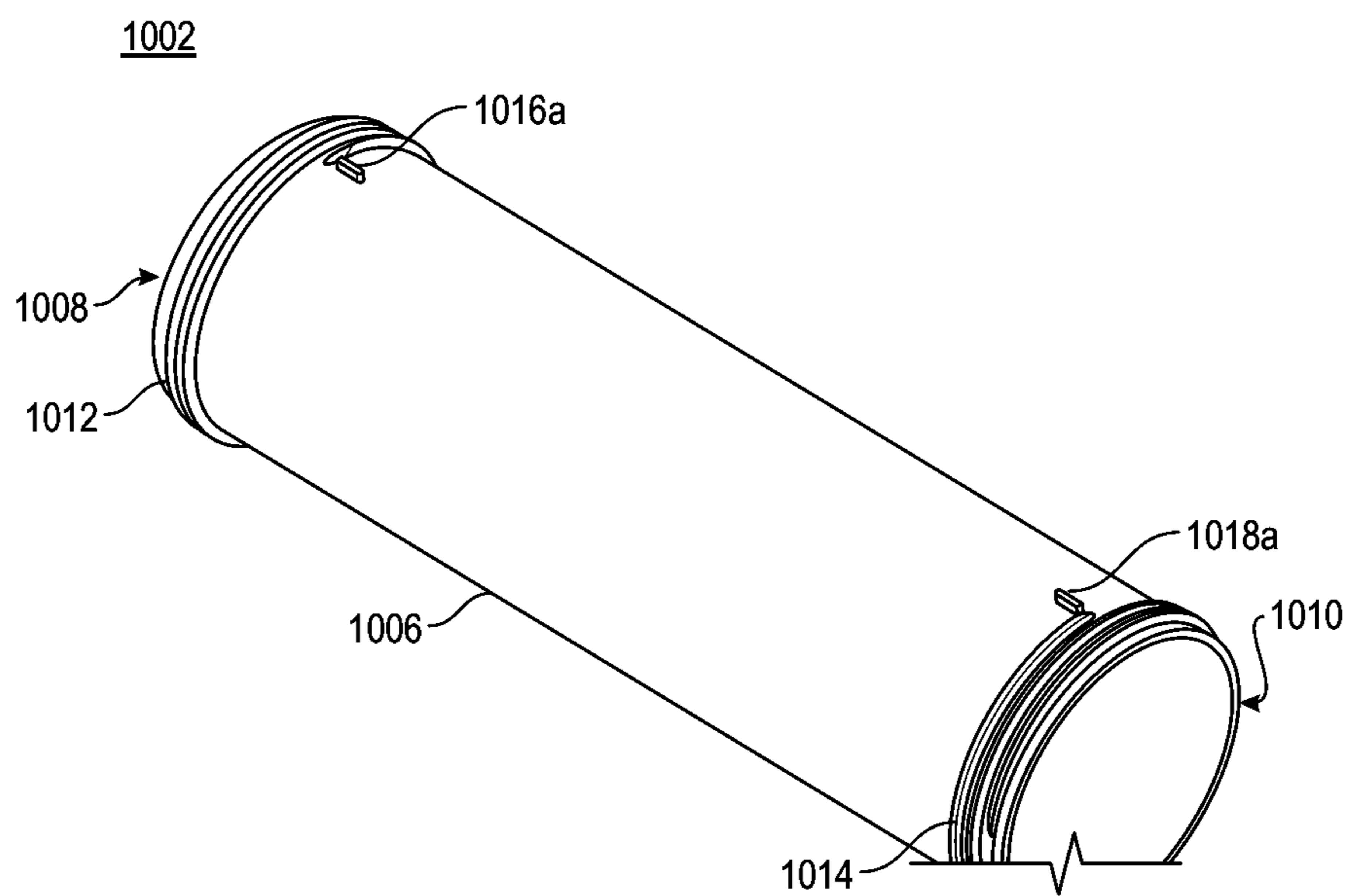

FIG. 10B

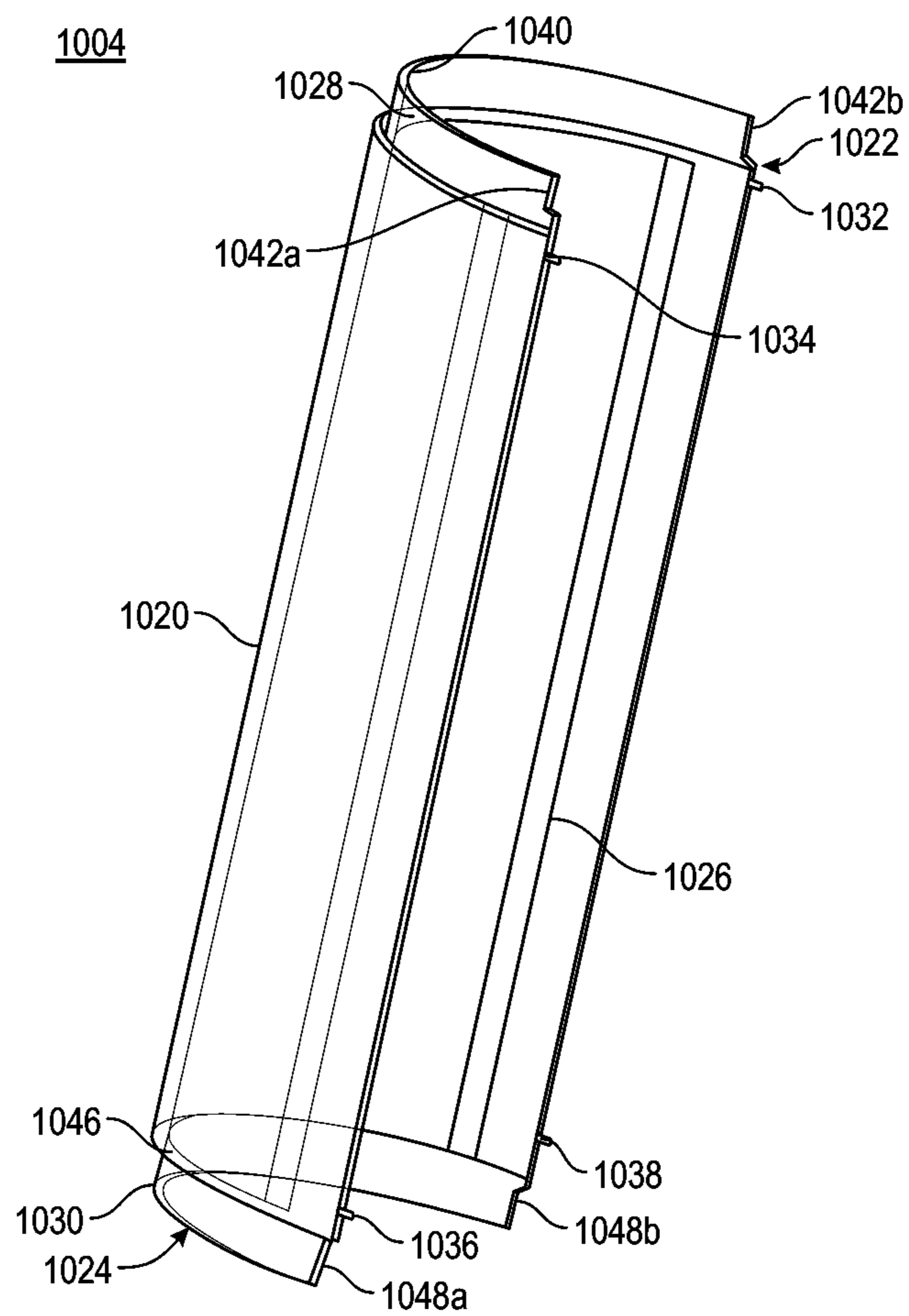

FIG. 10C

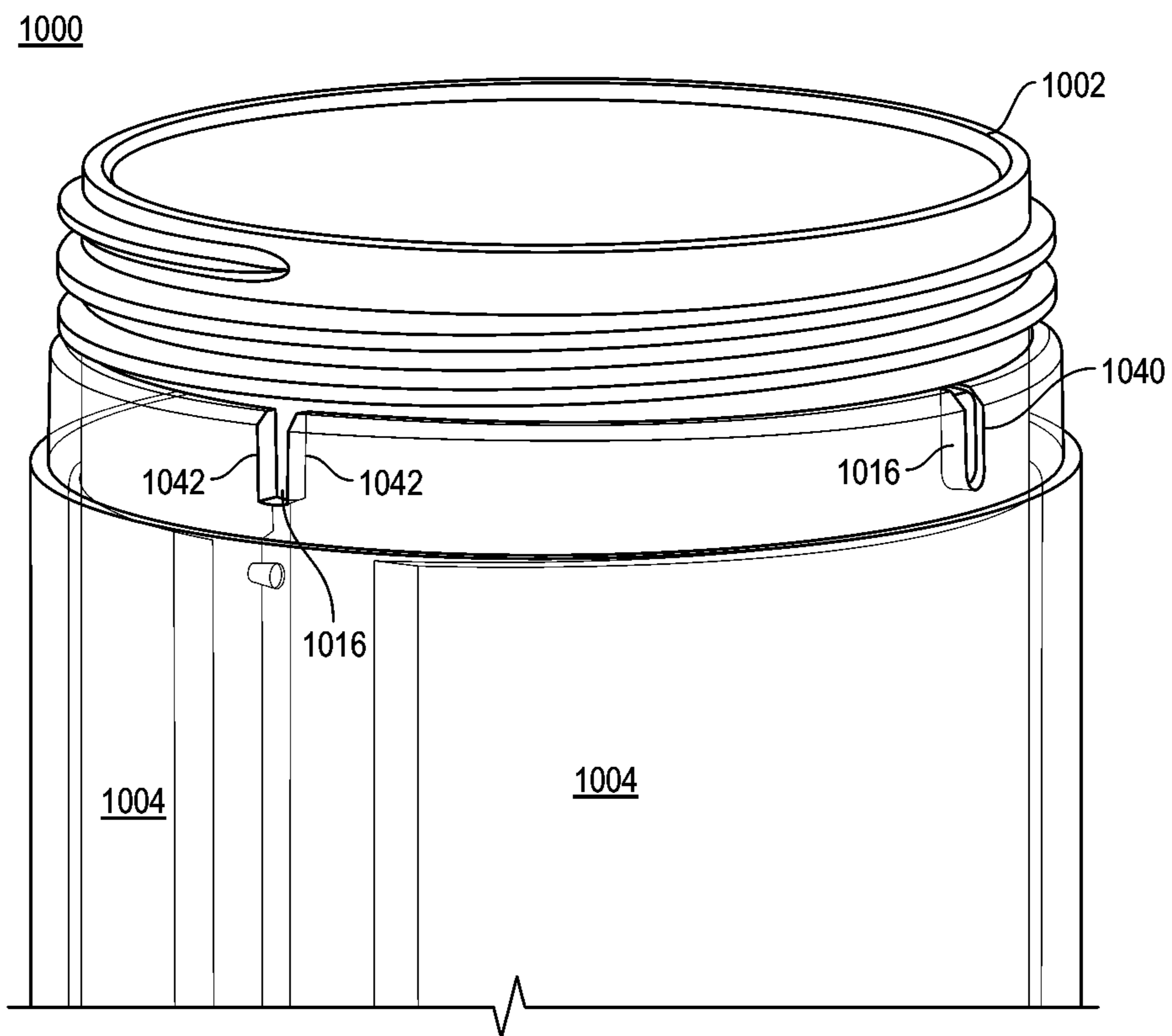

FIG. 10D

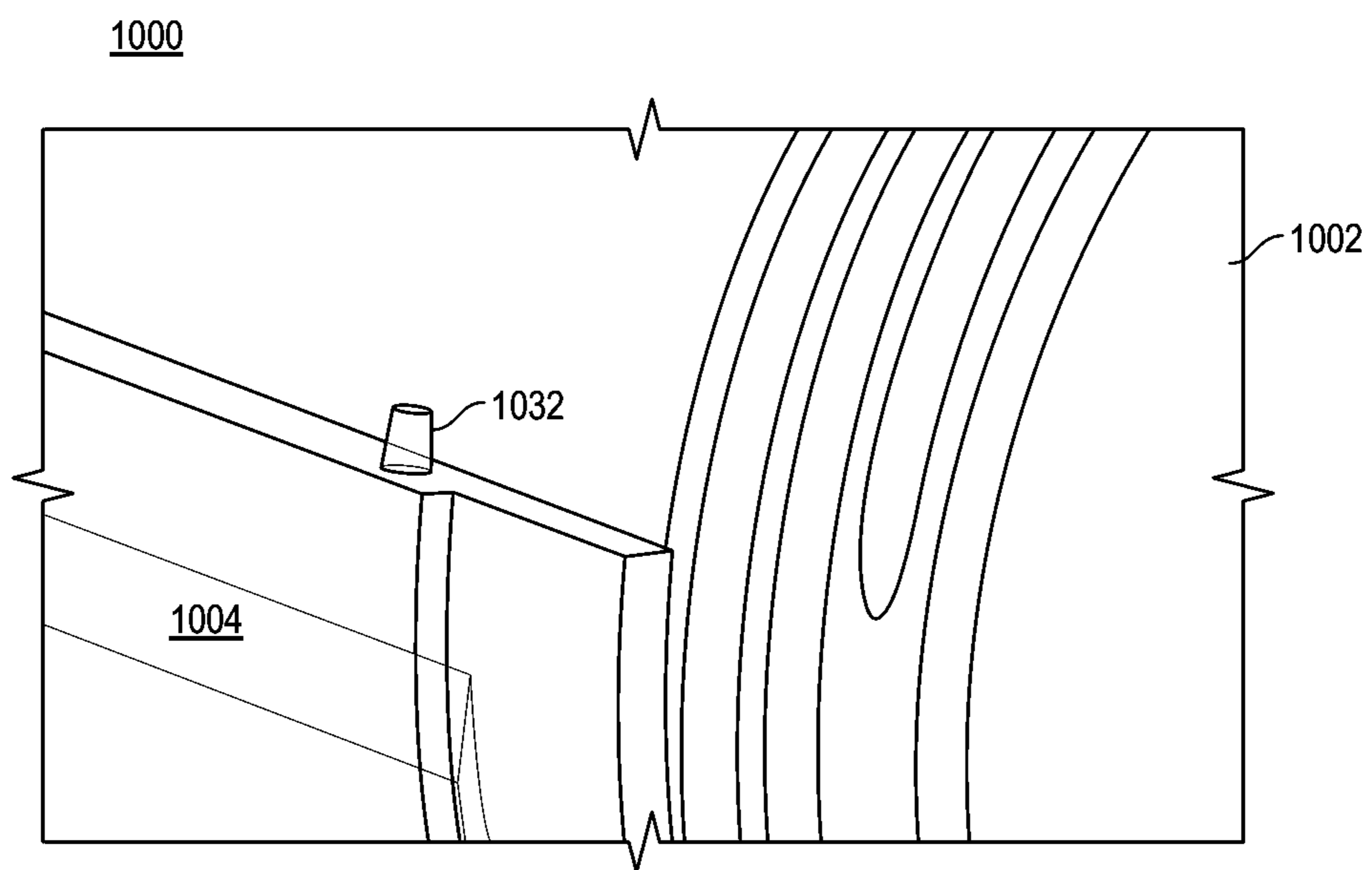

FIG. 10E

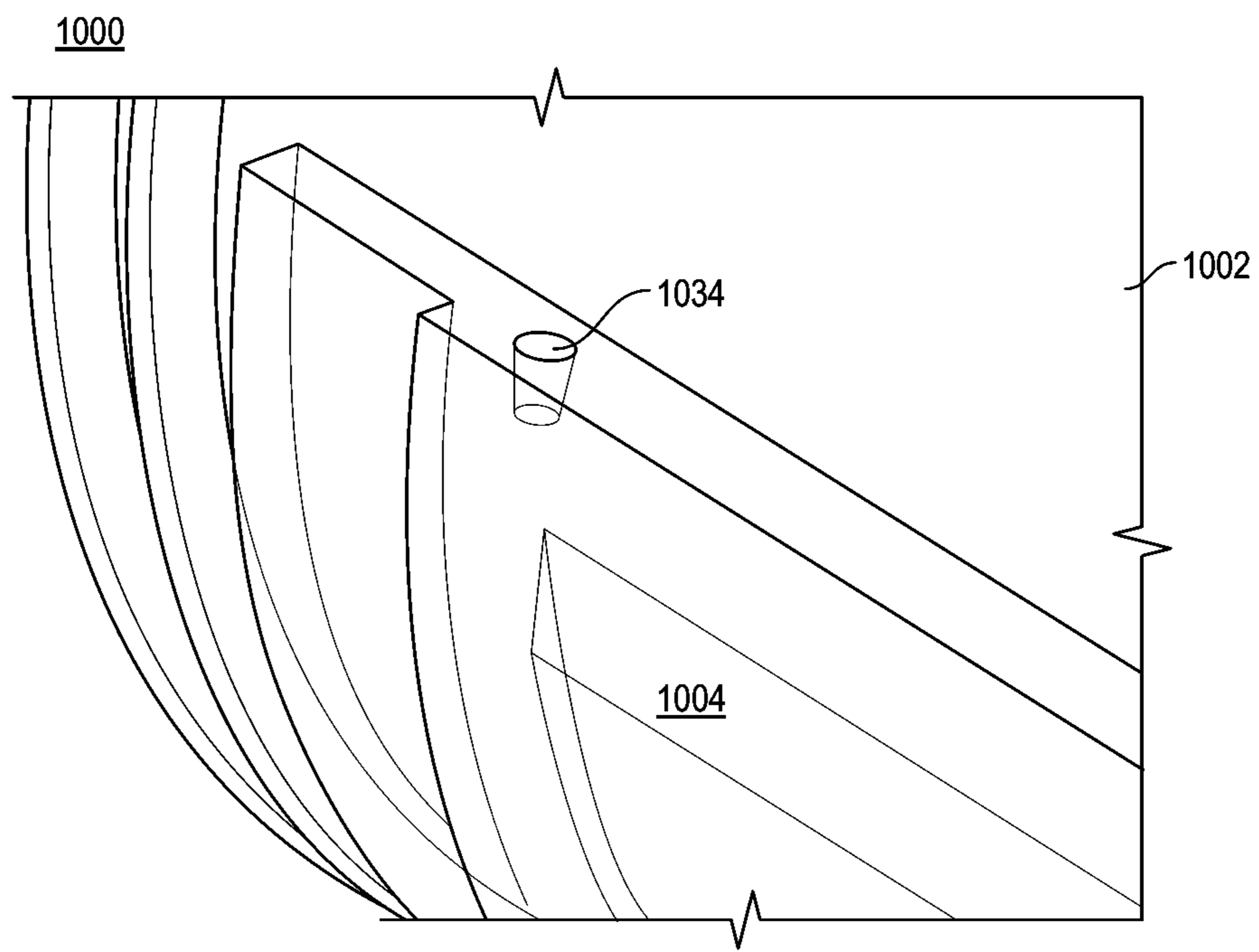

FIG. 10F

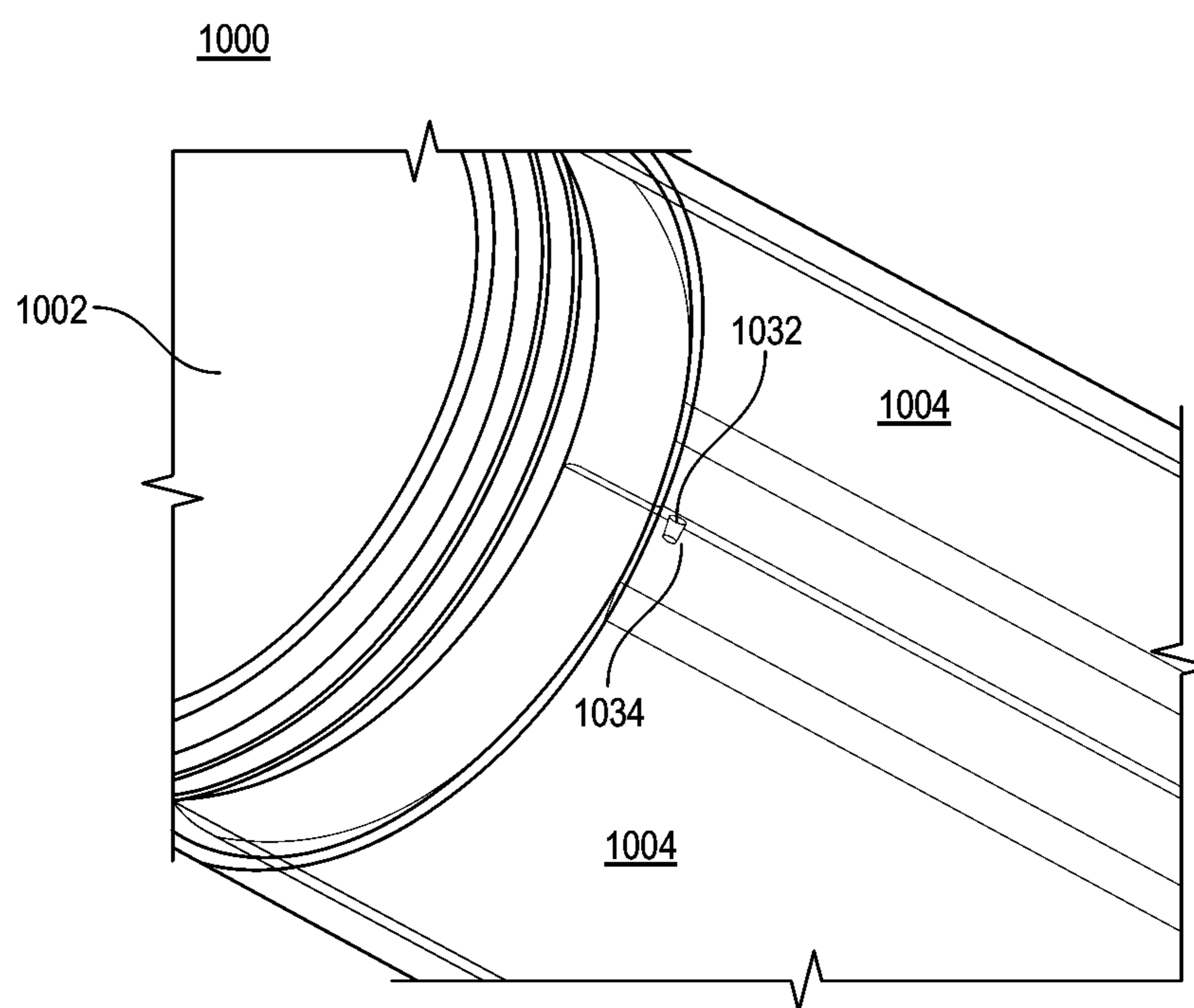

FIG. 10G

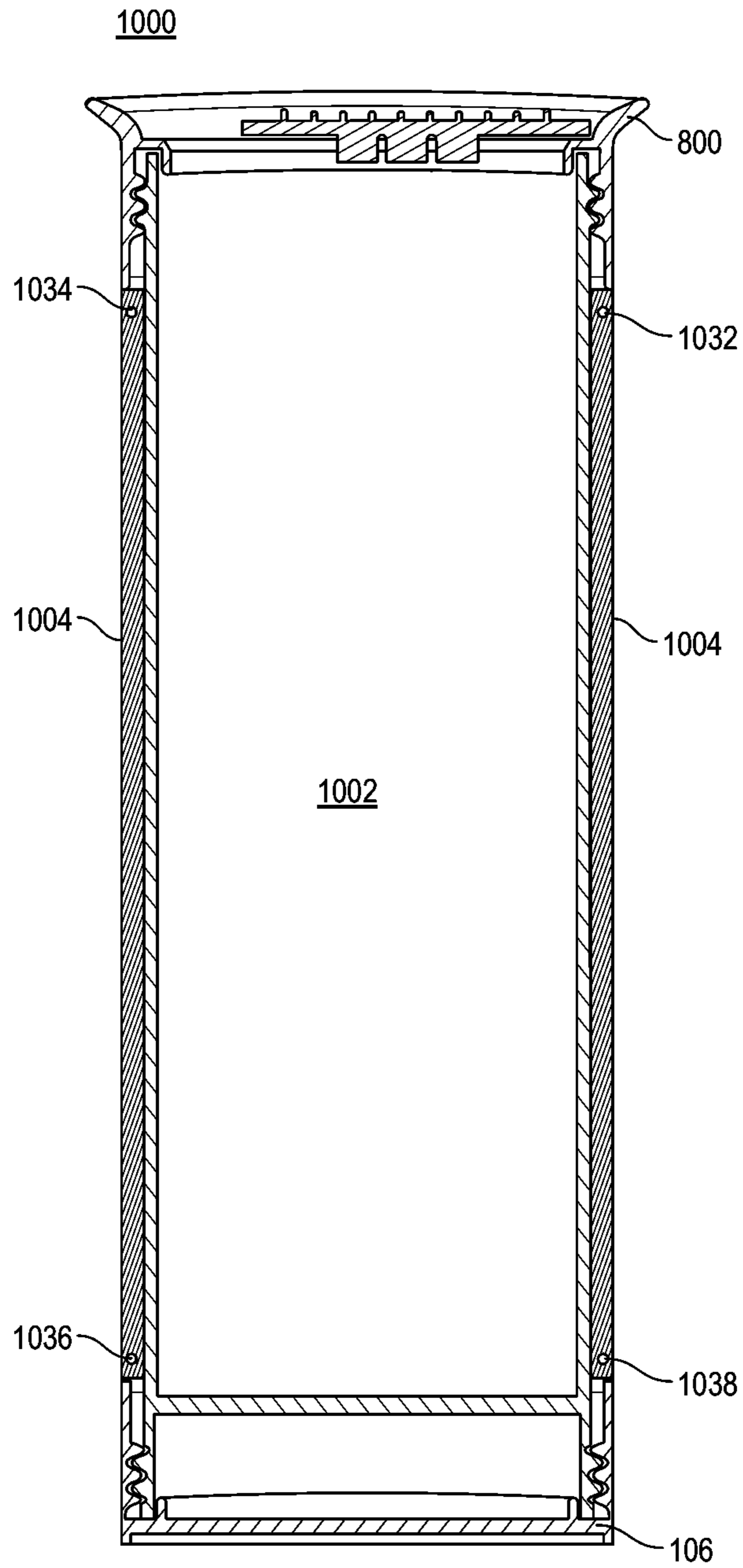

FIG. 10H

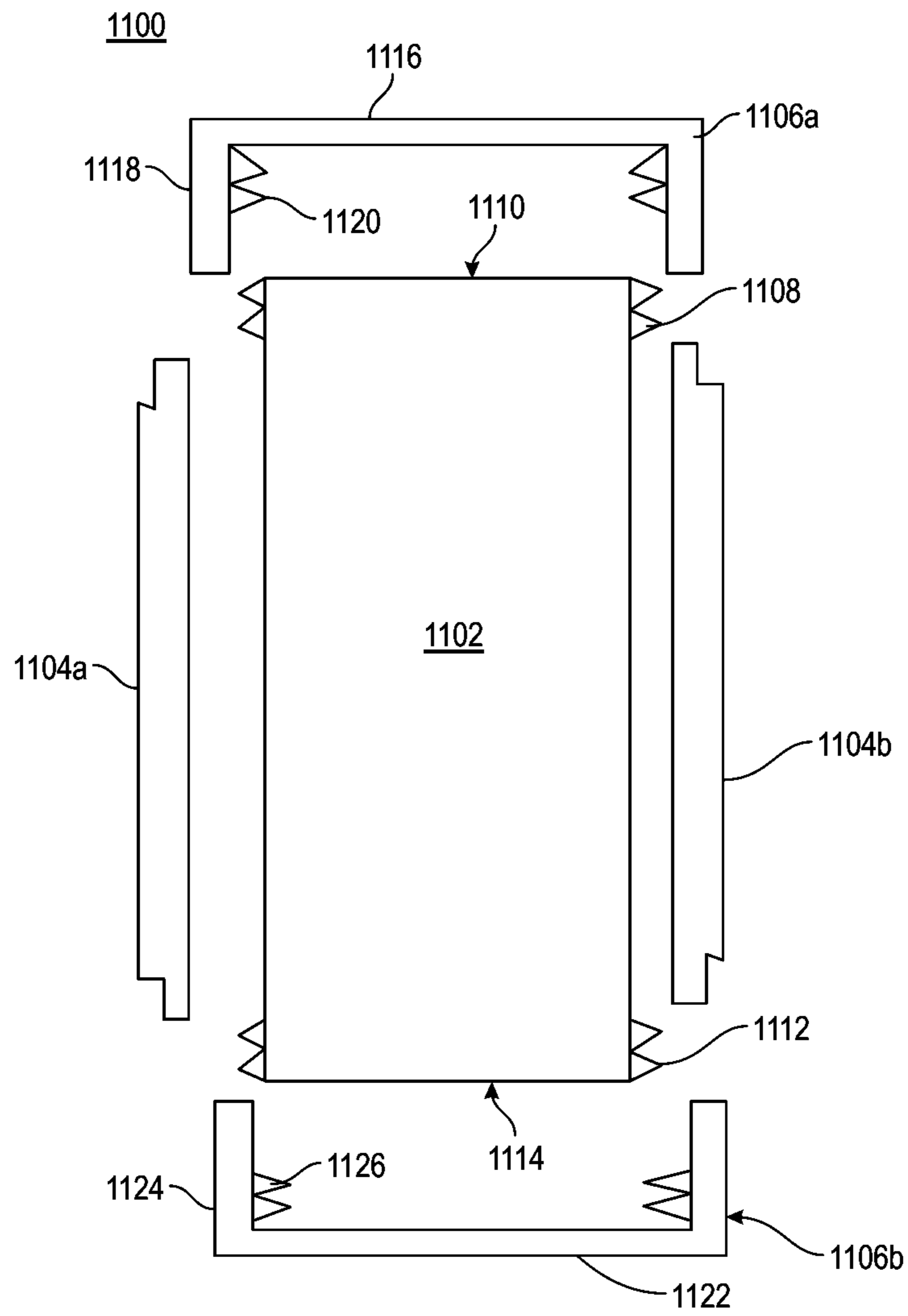

FIG. 11

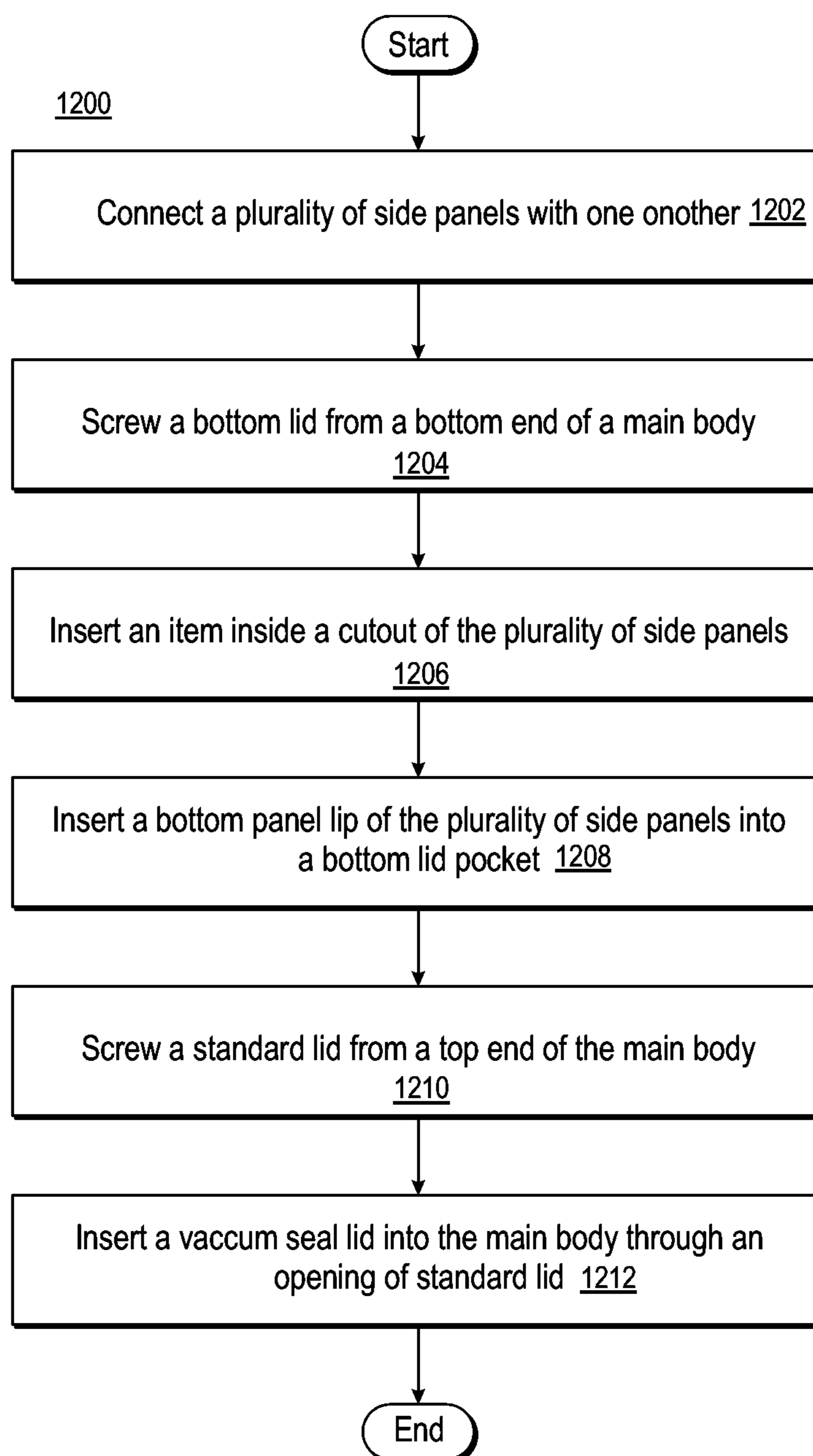

FIG. 12

1**CYLINDRICAL CONTAINER****CROSS REFERENCE TO RELATED APPLICATION**

This application claims benefit and priority to U.S. Provisional Patent Application Ser. No. 62/951,315, filed Dec. 20, 2019, entitled, "BEVERAGE CONTAINER" which is incorporated herein by reference in its entirety.

FIELD OF INVENTION

Embodiments disclosed herein relate, in general, to a container and, more particularly, to a customizable container for holding a substance such as, a solid or a liquid.

BACKGROUND

Beverage containers have been used for years. Conventional beverage containers are made up of rigid plastic material to hold a beverage and/or a fluid within. However, holding the conventional beverage containers containing a hot beverage or a cold beverage sometimes becomes difficult as insulation provided in such containers is not up to the mark. Moreover, a user has to buy multiple beverage containers according to different requirements, such as, a separate beverage container for a hot beverage, a beverage container for a cold beverage, a beverage container for travelling purpose having different sizes, and etc. For example, some users prefer to have their beverage in a coffee style lid while other users prefer to use a straw with the beverage container to consume the beverage. In addition, multiple beverage containers require ample amount of space in cabinets for their storage and can also have spending concerns.

Conventional beverage containers having a clear exterior body that screws onto a main body of the container and further allows for a piece of paper to slide into are readily available. Moreover, the surrounding cover of such beverage containers can be permanent and/or available to be removed and changed. However, an area for holding the paper is not big enough to provide an exact fitting to the paper, which can cause the paper to move freely. Moreover, the paper design can overlap itself causing an unpleasant look for the beverage container.

US20120012551A1 discloses a beverage container with an interchangeable sleeve and a fixed handle. The container is a mug with a lid and the fixed handle that has a sleeve meant for decorative purpose attached to the mug. Moreover, the sleeve has a lip on all sides meant to slide into grooves at a bottom side and the lid of the main mug. Further, the lid has a skirt to accept the lip so it is secure when closed. U.S. Ser. No. 10/669,070B2 discloses a beverage container with interchangeable components. The container has a very specific locking mechanism of "Key Holes", and a rail to secure internal and external embodiments, and then another part would be attached to that. Further, the rail is attached to a mug handle on a side of the container. However, there is no specific design for any attachable panels.

However, such conventional beverage containers have complex designs. Moreover, these conventional beverage containers require multiple inserts and attachments for different types and/or sizes of the beverage containers. In addition, one beverage container can attach only one type of

2

a lid. Therefore, a user has to buy multiple beverage containers having different type of lids for different usage purposes.

Thus, there is a need for a multipurpose cylindrical container that enables a user to easily customize and/or personalize the cylindrical container according to a specific need.

SUMMARY

Embodiments in accordance with the present invention provide a cylindrical container. The cylindrical container comprising: a main body, to store a beverage, wherein the main body comprising a top end and a bottom end. The cylindrical container further comprising a plurality of side panels, attached to one another, to form an insulated cover around the main body, wherein each of the plurality of side panels comprises a top panel lip and a bottom panel lip. Further, the cylindrical container comprises a bottom lid, having an exterior wall and an interior wall such that a height of the exterior wall is greater than a height of the interior wall, wherein an outer surface of the interior wall comprises a bottom lid thread to be screwed onto a bottom thread of an extended bottom wall provided at the bottom end of the main body. Further, the cylindrical container comprises a standard lid, having an exterior wall and an interior wall, wherein an outer surface of the interior wall comprises an interior lid thread to be screwed onto an interior thread of a lip provided at the top end of the main body. Further, the cylindrical container comprises a vacuum seal lid, having a flat top portion and a ring portion, wherein the ring portion comprises an O-ring hole along a circumference of the ring portion for accepting an O-ring to create a vacuum seal.

Embodiments in accordance with the present invention provide a cylindrical container. The cylindrical container comprising: a main body, to store a beverage, wherein the main body comprising a top end and a bottom end. The cylindrical container further comprising a plurality of side panels, attached to one another, to form an insulated cover around the main body, wherein each of the plurality of side panels comprises a top panel lip and a bottom panel lip. Further, the cylindrical container further comprises a bottom lid, having an exterior wall and an interior wall such that a height of the exterior wall is greater than a height of the interior wall, wherein an outer surface of the interior wall comprises a bottom lid thread to be screwed onto a bottom thread of an extended bottom wall provided at the bottom end of the main body. Further, the cylindrical container comprises a standard lid, having an exterior wall and an interior wall such that a height of the exterior wall is greater than a height of the interior wall, wherein an outer surface of the interior wall comprises an interior lid thread to be screwed onto an interior thread of a lip provided at the top end of the main body, wherein an inner surface of the exterior wall of the standard lid comprises an exterior lid thread to be screwed onto an exterior thread provided at the top end of the main body. Further, the cylindrical container comprises a vacuum seal lid, having a flat top portion and a ring portion, wherein the ring portion comprises an O-ring hole along a circumference of the ring portion for accepting an O-ring to create a vacuum seal.

Embodiments in accordance with the present invention provide a method for assembling a cylindrical container. The method comprising: connecting a plurality of side panels with one another to form an insulated cover to be attached around a main body, wherein each of the plurality of side

panels comprises a top panel lip and a bottom panel lip; screwing a bottom lid with the main body, wherein the bottom lid comprises a bottom lid thread on an outer surface of an interior wall, which is screwed onto a bottom thread of an extended bottom wall provided at a bottom end of the main body; inserting the bottom panel lip of each of the plurality of connected side panels into a bottom lid pocket of the bottom lid; screwing a standard lid, having an interior lid thread on an outer surface of an interior wall, onto an interior thread of a lip provided at a top end of the main body such that the top panel lip of each of the plurality of connected side panels is fixedly engaged within a top lid pocket of the standard lid; and attaching a vacuum seal lid, by pushing the vacuum seal lid into an opening of the main body such that an O-ring held within an O-ring hole of the vacuum seal lid creates a vacuum seal against the interior wall of the standard lid.

Embodiments in accordance with the present invention may provide a number of advantages depending on its particular configuration. First, embodiments of the present invention provide a cylindrical container having a plurality of side panels used to customize and/or personalize the cylindrical container. Next, embodiments of the present invention provide a cylindrical container having a plurality of side panels used as an insulating cover that protects hands of a user from a hot and/or a cold beverage stored in the cylindrical container and further protects the hot and/or the cold beverage stored in the cylindrical container from elements slowing a cooling and/or a heating rate of the stored beverage. Further, embodiments of the present invention provide a cylindrical container that may be used for advertisement purposes. Also, the embodiments of the present invention provide a cylindrical container that may allow the user to remove the advertisement provided by a seller and replace it with items of their choice in any shape and size.

Next, embodiments of the present invention provide a cylindrical container having an interchangeable top lid, an interchangeable bottom lid, and a plurality of side panels of different colors for changing a color combination of the cylindrical container. Further, each of the top lid, the bottom lid, as well as the side panels are designed of a plurality of different colors for changing a color combination of the cylindrical container. In addition, embodiments of the present invention provide a cylindrical container that may have the ability to get rid of multiple conventional space taking cylindrical containers that fills the cabinets. Next, embodiments of the present invention provide a cylindrical container that may support any type of a lid such as, but not limited to, a standard lid, a coffee style lid, a screw lid, etc. to meet the personal preferences of the user. Therefore, embodiments of the present invention provide a cylindrical container that may solve all the issues comprising, but not limited to, space saving, customization issues, spending concerns, drinking preferences, or ability to keep expressing or displaying items as per the user's choice.

These and other advantages will be apparent from the present application of the embodiments described herein.

The preceding is a simplified summary to provide an understanding of some embodiments of the present invention. This summary is neither an extensive nor exhaustive overview of the present invention and its various embodiments. The summary presents selected concepts of the embodiments of the present invention in a simplified form as an introduction to the more detailed description presented below. As will be appreciated, other embodiments of the

present invention are possible utilizing, alone or in combination, one or more of the features set forth above or described in detail below.

BRIEF DESCRIPTION OF THE DRAWINGS

The above and still further features and advantages of embodiments of the present invention will become apparent upon consideration of the following detailed description of embodiments thereof, especially when taken in conjunction with the accompanying drawings, and wherein:

FIG. 1A illustrates a front view of an assembled cylindrical container, according to an embodiment of the present invention;

FIG. 1B illustrates a side perspective view of the assembled cylindrical container, according to an embodiment of the present invention;

FIG. 2A illustrates a top perspective view of a main body of the cylindrical container, according to an embodiment of the present invention;

FIG. 2B illustrates a bottom perspective view of the main body of the cylindrical container, according to an embodiment of the present invention;

FIG. 2C illustrates a cross sectional view of the main body of the cylindrical container, according to an embodiment of the present invention;

FIG. 3A illustrates a perspective view of a side panel, according to an embodiment of the present invention;

FIG. 3B illustrates another perspective view of the side panel, according to an embodiment of the present invention;

FIG. 3C illustrates a front view of the side panel, according to an embodiment of the present invention;

FIG. 4A illustrates a top perspective view of a bottom lid, according to an embodiment of the present invention;

FIG. 4B illustrates a bottom perspective view of the bottom lid, according to an embodiment of the present invention;

FIG. 4C illustrates a cross sectional view of the bottom lid, according to an embodiment of the present invention;

FIG. 5A illustrates a bottom perspective view of a standard lid, according to an embodiment of the present invention;

FIG. 5B illustrates a top perspective view of the standard lid, according to an embodiment of the present invention;

FIG. 6A illustrates a cross sectional view of a vacuum seal lid, according to an embodiment of the present invention;

FIG. 6B illustrates a bottom perspective view of a slide, according to an embodiment of the present invention;

FIG. 6C illustrates a top perspective view of the slide, according to an embodiment of the present invention;

FIG. 7 illustrates a cross sectional view of an open top lid, according to another embodiment of the present invention;

FIG. 8A illustrates a perspective view of a screw lid, according to an embodiment of the present invention;

FIG. 8B illustrates a bottom perspective view of the screw lid, according to an embodiment of the present invention;

FIG. 8C illustrates a cross sectional view of a drinking lip of the screw lid, according to an embodiment of the present invention;

FIG. 8D illustrates a front view of the screw lid, according to an embodiment of the present invention;

FIG. 8E illustrates a cross sectional view of the screw lid, according to an embodiment of the present invention;

FIGS. 9A-9B illustrate different views of an assembled cylindrical container using the screw lid, according to an embodiment of the present invention;

5

FIG. 9C illustrates a cross sectional view of the assembled cylindrical container using the screw lid, according to an embodiment of the present invention;

FIG. 9D illustrates another cross sectional view of the assembled cylindrical container using the screw lid, according to an embodiment of the present invention;

FIG. 9E illustrates a perspective view of a ring adapter, according to an embodiment of the present invention;

FIG. 9F illustrates a perspective view of the ring adapter, according to another embodiment of the present invention;

FIG. 10A illustrates an exploded view of a cylindrical container, according to another embodiment of the present invention;

FIG. 10B illustrates a side perspective view of a main body of the cylindrical container, according to an embodiment of the present invention;

FIG. 10C illustrates one of a plurality of side panels of the cylindrical container, according to an embodiment of the present invention;

FIG. 10D illustrates a partial assembled view of the main body of the cylindrical container with the side panels, according to an embodiment of the present invention;

FIG. 10E illustrates a top male alignment feature of the side panels enclosing the main body of the cylindrical container, according to an embodiment of the present invention;

FIG. 10F illustrates a top female alignment feature of the side panels enclosing the main body of the cylindrical container, according to an embodiment of the present invention;

FIG. 10G illustrates another partial view of the cylindrical container with the side panels attached to the main body, according to another embodiment of the present invention;

FIG. 10H illustrates a cross sectional view of the assembled cylindrical container, according to an embodiment of the present invention;

FIG. 11 illustrates a cross sectional view of a cylindrical container to be used as a jar, according to an embodiment of the present invention; and

FIG. 12 illustrates a flowchart of a method for assembling the cylindrical container, according to an embodiment of the present invention.

The headings used herein are for organizational purposes only and are not meant to be used to limit the scope of the description or the claims. As used throughout this application, the word “may” is used in a permissive sense (i.e., meaning having the potential to), rather than the mandatory sense (i.e., meaning must). Similarly, the words “include”, “including”, and “includes” mean including but not limited to. To facilitate understanding, like reference numerals have been used, where possible, to designate like elements common to the figures. Optional portions of the figures may be illustrated using dashed or dotted lines, unless the context of usage indicates otherwise.

DETAILED DESCRIPTION

The phrases “at least one”, “one or more”, and “and/or” are open-ended expressions that are both conjunctive and disjunctive in operation. For example, each of the expressions “at least one of A, B and C”, “at least one of A, B, or C”, “one or more of A, B, and C”, “one or more of A, B, or C” and “A, B, and/or C” means A alone, B alone, C alone, A and B together, A and C together, B and C together, or A, B and C together.

The term “a” or “an” entity refers to one or more of that entity. As such, the terms “a” (or “an”), “one or more” and

6

“at least one” can be used interchangeably herein. It is also to be noted that the terms “comprising”, “including”, and “having” can be used interchangeably.

FIG. 1A illustrates a front view of an assembled cylindrical container 100, according to an embodiment of the present invention. The cylindrical container 100 may be a cylindrically shaped container designed to hold a beverage, in an embodiment of the present invention. The beverage may be, but not limited to, water, coffee, tea, juice, and so forth. Embodiments of the present invention are intended to include or otherwise cover any type of the beverage, including known, related art, and/or later developed beverages. In another embodiment of the present invention, the cylindrical container 100 may be designed to hold a solid material, such as, but not limited to, a cooking powder, a seasoning, a bead, a craft item, and so forth. Embodiments of the present invention are intended to include or otherwise cover any type of the solid material, including known, related art, and/or later developed solid materials. According to embodiments of the present invention, the cylindrical container 100 comprises a main body 102 (as shown in FIG. 2A), a plurality of side panels 104a-104b (hereinafter referred to as the side panels 104), a bottom lid 106, and a standard lid 108 that may be used as a top lid for sealing the cylindrical container 100. Further, to assemble the cylindrical container 100, the main body 102, the side panels 104, the bottom lid 106, and the standard lid 108 may be attached to one another, according to an embodiment of the present invention.

FIG. 1B illustrates a side perspective view of the assembled cylindrical container 100, according to an embodiment of the present invention. The cylindrical container 100 comprises the main body 102 (as shown in the FIG. 2A), the side panels 104, the bottom lid 106, and the standard lid 108 to be used as the top lid for sealing the cylindrical container 100.

FIG. 2A illustrates a top perspective view of the main body 102 of the cylindrical container 100, according to an embodiment of the present invention. The main body 102 may be a cylindrical shaped enclosed structure designed to hold the beverage and/or the solid material. Further, a size of the main body 102 may be designed such that a beverage holding capacity and/or a solid material holding capacity of the main body 102 may be, but not limited to, 8 ounces, 16 ounces, 64 ounces, and so forth. Embodiments of the present invention are intended to include or otherwise cover any of the size of the main body 102. Further, the main body 102 may be made up of a material such as, but not limited to, a plastic, a metal, wood, and so forth. Embodiments of the present invention are intended to include or otherwise cover any type of the material for the main body 102, including known, related art, and/or later developed technologies.

According to an embodiment of the present invention, the main body 102 may comprise a side wall 200, a top end 202, and a bottom end 204, in an embodiment of the present invention. Further, the top end 202 may have an opening 206 that may allow an access to a hollow chamber formed within the side wall 200, and the bottom end 204. The hollow chamber of the main body 102 may be used for storing the beverage, according to an embodiment of the present invention. Further, the main body 102 may comprise an exterior thread 208 along an outer surface of the side wall 200 near the top end 202. The exterior thread 208 may be designed such that the side panels 104 may rest under the exterior thread 208 while assembling the cylindrical container 100, in an embodiment of the present invention. Furthermore, the main body 102 may comprise a lip 210 at the top end 202 along the side wall 200. The lip 210 may comprise an

interior thread **212** along an inner surface that may be provided to accept the standard lid **108** while assembling the cylindrical container **100**, in an embodiment of the present invention. In an embodiment of the present invention, a thickness of the lip **210** may be less than a thickness of the side wall **200** such that when the standard lid **108** is screwed with the main body **102**, it provides a flush look to an inside of the cylindrical container **100**.

FIG. 2B illustrates a bottom perspective view of the main body **102** of the cylindrical container **100**, according to an embodiment of the present invention. The side wall **200** of the main body **102** may comprise an extended bottom wall **214** at the bottom end **204** that may be provided to accept the bottom lid **106** (as shown in FIG. 4A), in an embodiment of the present invention. Further, the extended bottom wall **214** may comprise a bottom thread **216** on an inner surface to accept the bottom lid **106** while assembling the cylindrical container **100**, in an embodiment of the present invention. In another embodiment of the present invention, the extended bottom wall **214** may comprise the bottom thread **216** on an outer surface to accept the bottom lid **106** while assembling the cylindrical container **100**.

FIG. 2C illustrates a cross sectional view of the main body **102** of the cylindrical container **100**, according to an embodiment of the present invention. In an embodiment of the present invention, the main body **102** may have an inner diameter of 60 Millimeters (mm) and an outer diameter of 66 mm. Further, a thickness of the side wall **200** may be 3 mm, according to an embodiment of the present invention. The lip **210** of the main body **102** may have a height of 10 mm and a total height of the main body **102** including the lip **210** and the extended bottom wall **214** may be 193 mm, according to an embodiment of the present invention.

FIG. 3A illustrates a perspective view of the side panel **104**, according to an embodiment of the present invention. The side panel **104** may have a semi-cylindrical shape that may be attached to a second side panel **104** forming a cover for the main body **102** for a customization and/or a personalization of the cylindrical container **100**, according to an embodiment of the present invention. Further, the side panels **104** may be made up of a transparent material such as, but not limited to, a plastic, a rubber, a Polyvinyl Chloride (PVC), an acrylic, a polycarbonate, and so forth. Embodiments of the present invention are intended to include or otherwise cover any type of the transparent material for making the side panels **104**, including known, related art, and/or later developed technologies. The side panels **104** may comprise a body **300**, a top edge **302**, and a bottom edge **304**. Further, the body **300** may comprise a cutout **306** on an inner surface of the side panel **104**, which may act like a frame to fixedly hold an item. The item may be for example, but not limited to, a business card, a photograph, a printed design, and so forth, which may be used for advertisement purposes, entertainment purposes, etc. Embodiments of the present invention are intended to include or otherwise cover any of the item to be fixedly held within the cutout **306**, including known, related art, and/or later developed technologies. The cutout **306** may be a pocket that may be fixedly attached to the inner surface of the body **300**, in an embodiment of the present invention. In another embodiment of the present invention, the cutout **306** may be removably attached to the inner surface of the body **300**. Further, the cutout **306** may be made up of a material such as, but not limited to, a plastic, a rubber, a Polyvinyl Chloride (PVC), an acrylic, a polycarbonate, and so forth. Embodiments of the present invention are intended to include or otherwise cover type of the material for making

the cutout **306**, including known, related art, and/or later developed technologies. According to another embodiment of the present invention, the side panels **104** may be designed in a plurality of colors such as, but not limited to, a red, a blue, a green, a black, a white, and so forth. Embodiments of the present invention are intended to include or otherwise cover any of the color for the side panels **104**, including known, related art, and/or later developed technologies.

In an embodiment of the present invention, the side panels **104** may comprise a default pattern printed on an outer surface of the body **300**. The default pattern may be, but not limited to, a picture, a design, and so forth. Embodiments of the present invention are intended to include or otherwise cover any of the default pattern printed onto the outer surface of the side panels **104**, including known, related art, and/or later developed technologies. According to an embodiment of the present invention, the side panels **104** may be attached to the main body **102** of the cylindrical container **100** to provide an insulation to a user holding the cylindrical container **100** containing a hot beverage and/or a cold beverage. Further, the side panels **104** may provide an insulation to the beverage stored in the main body **102** of the cylindrical container **100** from outside environment that may slow down a heating rate and/or a cooling rate of the beverage inside the cylindrical container **100**.

In an embodiment of the present invention, the side panels **104** may comprise a top panel lip **308** near the top edge **302** along the body **300** and a bottom panel lip **310** near the bottom edge **304** along the body **300**. In another embodiment of the present invention, the side panels **104** may comprise only the bottom panel lip **310** near the bottom edge **304** along the body **300**. Further, a thickness of the top panel lip **308** and a thickness of the bottom panel lip **310** may be less than a thickness of the body **300** of the side panels **104**. Furthermore, the top panel lip **308** and the bottom panel lip **310** may be designed to slide and fit within a top lid pocket **506** of the standard lid **108** (as shown in FIG. 5A) and a bottom lid pocket **406** of the bottom lid **106** (as shown in FIG. 4A), according to an embodiment of the present invention.

FIG. 3B illustrates another perspective view of the side panel **104**, according to an embodiment of the present invention. The side panels **104** may have the semi-cylindrical shape that may be attached to another side panel **104** forming the cover for insulating and/or customizing the main body **102** of the cylindrical container **100**, according to an embodiment of the present invention. The side panels **104** may comprise the body **300**, the top edge **302**, and the bottom edge **304**, as discussed above in conjunction with the FIG. 3A.

FIG. 3C illustrates a front view of the side panels **104**, according to an embodiment of the present invention. In an embodiment of the present invention, a height of the body **300** of the side panels **104** may be 169 Millimeters (mm). Further, a height of the top panel lip **308** and a height of the bottom panel lip **310** may be 5 mm, according to an embodiment of the present invention. Therefore, a total height of the side panel **104** may be 179 mm.

FIG. 4A illustrates a top perspective view of the bottom lid **106**, according to an embodiment of the present invention. The bottom lid **106** may be designed to be screwed onto the bottom thread **216** of the extended bottom wall **214** of the main body **102** for assembling the cylindrical container **100**, according to an embodiment of the present invention. The bottom lid **106** may comprise a bottom surface **400**, an exterior wall **402**, and an interior wall **404**, in an embodi-

ment of the present invention. Further, the bottom surface **400**, the exterior wall **402**, and the interior wall **404** may be made up of a material such as, but not limited to, a plastic, wood, a metal, and so forth. Embodiments of the present invention are intended to include or otherwise cover any type of the material for making the bottom surface **400**, the exterior wall **402**, and the interior wall **404**, including known, related art, and/or later developed technologies. Furthermore, the bottom surface **400**, the exterior wall **402**, and the interior wall **404** may be designed in a plurality of colors such as, but not limited to, a red, a blue, a green, and so forth. Embodiments of the present invention are intended to include or otherwise cover any color for the bottom surface **400**, the exterior wall **402**, and the interior wall **404**, including known, related art, and/or later developed colors. According to an embodiment of the present invention, the bottom surface **400** may be a flat platform that may act as a rigid support for the exterior wall **402** and the interior wall **404** that may be fixedly attached onto the bottom surface **400** forming a plurality of concentric circles. Further, the exterior wall **402** and the interior wall **404** may extend vertically upwards from the bottom surface **400** to form the bottom lid pocket **406**, in an embodiment of the present invention. According to an embodiment of the present invention, the exterior wall **402** may have a height that may be greater than a height of the interior wall **404**.

Further, the bottom lid pocket **406** may be provided to accept the bottom panel lip **310** of the side panels **104** (as shown in the FIG. 3A) for assembling the cylindrical container **100**, in an embodiment of the present invention. According to an embodiment of the present invention, an outer surface of the interior wall **404** may comprise a bottom lid thread **408** that may be used to screw the bottom lid **106** onto the bottom thread **216** of the extended bottom wall **214** of the main body **102**. Further, the bottom lid **106** screwed onto the main body **102** may form a small compartment between the bottom end **204** of the main body **102** and the bottom surface **400** of the bottom lid **106**, in an embodiment of the present invention. The small compartment may be provided to securely hold objects such as, but not limited to, money, a ticket, and so forth. Embodiments of the present invention are intended to include or otherwise cover any object to be securely held within the small compartment, including known, related art, and/or later developed technologies.

FIG. 4B illustrates a bottom perspective view of the bottom lid **106**, according to an embodiment of the present invention. The bottom lid **106** may comprise the bottom surface **400** and the exterior wall **402** as discussed above in conjunction with the FIG. 4A. Further, the exterior wall **402** may comprise an extended bottom wall **410** that may extend below the bottom surface **400** to provide a stable base for placing the assembled cylindrical container **100** over a flat surface, according to an embodiment of the present invention.

FIG. 4C illustrates a cross sectional view of the bottom lid **106**, according to an embodiment of the present invention. In an embodiment of the present invention, the exterior wall **402** of the bottom lid **106** may have an inner diameter of 69 Millimeters (mm) and an outer diameter of 72 mm. Further, a thickness of the exterior wall **402** may be 1.5 mm, according to an embodiment of the present invention. A height of the bottom lid **106** may be 15 mm and a height of the extended bottom wall **410** may be 2 mm, according to an embodiment of the present invention. Therefore, a total height of the bottom lid **106** may be 17 mm.

FIG. 5A illustrates a bottom perspective view of the standard lid **108**, according to an embodiment of the present invention. The standard lid **108** may be designed to be screwed onto the top end **202** of the main body **102** for assembling the cylindrical container **100** that may be open like a regular household drinking cup. In an embodiment of the present invention, the standard lid **108** may be designed to be screwed onto the interior thread **212** of the lip **210** of the main body **102** (as shown in the FIG. 2A) for assembling the cylindrical container **100**. In another embodiment of the present invention, the standard lid **108** may be designed to be screwed onto the exterior thread **208** of the main body **102** for assembling the cylindrical container **100**. The standard lid **108** may comprise an exterior wall **500**, and an interior wall **502**. The exterior wall **500** and the interior wall **502** may be made up of a material such as, but not limited to, a plastic, wood, a metal, and so forth. Embodiments of the present invention are intended to include or otherwise cover any type of the material for making the exterior wall **500** and the interior wall **502**, including known, related art, and/or later developed technologies. Further, the exterior wall **500** and the interior wall **502** may be designed in a plurality of colors such as, but not limited to, a red, a blue, a green, and so forth. Embodiments of the present invention are intended to include or otherwise cover any color for the exterior wall **500** and the interior wall **502**, including known, related art, and/or later developed colors. According to an embodiment of the present invention, the exterior wall **500** and the interior wall **502** may be fixedly attached to one another through a connecting surface **504** (as shown in FIG. 5B) thus forming a plurality of concentric circles. The connecting surface **504** may form a rounded surface between the exterior wall **500** and the interior wall **502**, in an embodiment of the present invention. Further, the exterior wall **500** and the interior wall **502** may extend vertically upwards from the connecting surface **504** to form the top lid pocket **506**, according to an embodiment of the present invention. In an embodiment of the present invention, the exterior wall **500** may have a height that may be greater than a height of the interior wall **502**.

Further, the top lid pocket **506** may be provided to accept the top panel lip **308** of the side panels **104** (as shown in the FIG. 3A) for assembling the cylindrical container **100**, in an embodiment of the present invention. Further, an outer surface of the interior wall **502** of the standard lid **108** may comprise an interior lid thread **508** that may be used to screw the standard lid **108** onto the interior thread **212** of the lip **210** of the main body **102** for assembling the cylindrical container **100**, in an embodiment of the present invention. According to another embodiment of the present invention, an inner surface of the exterior wall **500** may comprise an exterior lid thread **510** that may be used to screw the standard lid **108** onto the exterior thread **208** of the main body **102** for assembling the cylindrical container **100**. According to yet another embodiment of the present invention, the outer surface of the interior wall **502** may comprise the interior lid thread **508** and the inner surface of the exterior wall **500** may comprise the exterior lid thread **510** to screw the standard lid **108** onto the main body **102** of a corresponding size for converting the main body **102** of any size into a vacuum seal lid **600** (as shown in FIG. 6A) compatible with the main body **102**.

FIG. 5B illustrates a top perspective view of the standard lid **108**, according to an embodiment of the present invention. The standard lid **108** may comprise the exterior wall

500 and the interior wall 502 attached to each other through the connecting surface 504 as discussed in conjunction with the FIG. 5A.

FIG. 6A illustrates a cross sectional view of the vacuum seal lid 600, according to an embodiment of the present invention. The vacuum seal lid 600 may be used along with the standard lid 108 (as explained in the FIG. 5A and FIG. 5B) to provide a vacuum seal to the cylindrical container 100, according to an embodiment of the present invention. In another embodiment of the present invention, the standard lid 108 may be used internally allowing for the bottom lid 106 to be held through the vacuum seal lid 600. In an embodiment of the present invention, the standard lid 108 may be first screwed onto the interior thread 212 present along the inner surface of the lip 210 of the main body 102 to cover the interior thread 212. Further, the vacuum seal lid 600 may be inserted and pressed into the opening 206 of the main body 102 that may cause the vacuum seal lid 600 to create a vacuum with the interior wall 502 of the standard lid 108 resulting in a vacuum seal for the cylindrical container 100. According to an embodiment of the present invention, the vacuum seal lid 600 comprises a flat top portion 602, a ring portion 604, and a drinking lip 606. Further, the flat top portion 602, the ring portion 604, and the drinking lip 606 may be made up of a material such as, but not limited to, a plastic, a natural rubber, a synthetic rubber, a metal, wood, and so forth. Embodiments of the present invention are intended to include or otherwise cover any type of the material for making the flat top portion 602, the ring portion 604, and the drinking lip 606, including known, related art, and/or later developed technologies. In an embodiment of the present invention, the flat top portion 602, the ring portion 604, and the drinking lip 606 may be fabricated as a single piece. In another embodiment of the present invention, the flat top portion 602, the ring portion 604, and the drinking lip 606 may be fabricated as a plurality of discrete pieces that may be attached together to form the vacuum seal lid 600. Further, the flat top portion 602, the ring portion 604, and the drinking lip 606 may be designed in a plurality of colors such as, but not limited to, a red, a blue, a green, and so forth. Embodiments of the present invention are intended to include or otherwise cover any color for the flat top portion 602, the ring portion 604, and the drinking lip 606, including known, related art, and/or later developed colors.

In an embodiment of the present invention, the flat top portion 602 may further comprise a cavity (not shown) that may form an opening for accepting a slide 620 (as show in FIG. 6B) to seal a drinking hole 608 and the opening when the cylindrical container 100 is not in use. In an embodiment of the present invention, the drinking hole 608 may allow the user of the cylindrical container 100 to easily sip the beverage contained in the cylindrical container 100. According to an embodiment of the present invention, the drinking hole 608 may be a half oval shaped drinking hole that may be capable of holding a straw (not shown). Further, the slide 620 may be capable of closing the drinking hole 608 completely when the user slides the slide 620 above the drinking hole 608 and fits the slide 620 into an indent (not shown) present in the drinking lip 606, thus covering the drinking hole 608 and restricting the flow of the beverage out of the cylindrical container 100, according to an embodiment of the present invention. Furthermore, the flat top portion 602 may comprise a bottom face 610 and a top face 612, according to an embodiment of the present invention. The bottom face 610 may comprise a rounded cut 614 provided along a perimeter of the bottom face 610 that may

be designed to fit over the connecting surface 504 of the standard lid 108 when the vacuum seal lid 600 is pressed over the standard lid 108 for attaching the vacuum seal lid 600 to the cylindrical container 100, in an embodiment of the present invention. According to an embodiment of the present invention, a height of the flat top portion 602 may be in a range of 1 Millimeter (mm) to 3 mm.

The ring portion 604 may be designed to fit against the interior wall 502 of the standard lid 108 when the vacuum seal lid 600 is attached onto the standard lid 108, in an embodiment of the present invention. According to an embodiment of the present invention, a diameter of the ring portion 604 may be less than the diameter of the main body 102. Further, the ring portion 604 may comprise an O-ring hole 616 along the circumference of the ring portion 604 that may be provided to accept an O-ring or a ring adapter (not shown) forming a ring gasket that may fill in a gap created by the O-ring hole 616 between the interior wall 502 of the standard lid 108 and the ring portion 604 of the vacuum seal lid 600 causing the vacuum seal, in an embodiment of the present invention. Further, the bottom face 610 of the ring portion 604 may comprise an angled edge 618 that may be provided to assist in the flow of the beverage. The angled edge 618 may have a height in a range of 1 mm to 4 mm, according to embodiments of the present invention. In an embodiment of the present invention, the O-ring hole 616 may have a width of 2 mm and a height of 5 mm. Further, a total height of the ring portion 604 may be 10 mm, in an embodiment of the present invention. In an embodiment of the present invention, the drinking lip 606 may be provided to enable the user of the cylindrical container 100 to easily sip the beverage contained in the cylindrical container 100. The drinking lip 606 may be an angled elevated boundary attached to the top face 612 of the flat top portion 602 that may wrap around the perimeter of the vacuum seal lid 600. According to an embodiment of the present invention, a height of the drinking lip 606 may be 10 mm.

FIG. 6B illustrates a bottom perspective view of the slide 620, according to an embodiment of the present invention. The slide 620 may be a rigid rectangular piece used to seal the drinking hole 608 and the opening present in the flat top portion 602 of the vacuum seal lid 600, in an embodiment of the present invention. In another embodiment of the present invention, the slide 620 may be used to seal a screw lid 800 (as shown in FIG. 8A). According to embodiments of the present invention, the slide 620 may be made up of a material such as, but not limited to, a plastic, a natural rubber, a synthetic rubber, wood, a metal, and so forth. Embodiments of the present invention are intended to include or otherwise cover any type of the material for making the slide 620, including known, related art, and/or later developed technologies. Further, the slide 620 may be designed in a plurality of colors such as, but not limited to, a red, a blue, a green, and so forth. Embodiments of the present invention are intended to include or otherwise cover any color for the slide 620, including known, related art, and/or later developed colors. In an embodiment of the present invention, the slide 620 may comprise a plurality of clips 622a-622c (hereinafter referred to as the clips 622) attached to a bottom face of the slide 620, in an embodiment of the present invention. The clips 622 may comprise rounded top portion that may be provided to be engaged within the cavity of the flat top portion 602 of the vacuum seal lid 600 when the slide 620 is snapped into the cavity, according to an embodiment of the present invention. The slide 620 may be capable of sliding within the cavity for opening and/or closing the drinking hole 608 of the vacuum

13

seal lid 600, according to an embodiment of the present invention. Further, the slide 620 may comprise an air hole 624 that may be provided to allow a passage of air into the cylindrical container 100 for a smooth pour of the beverage, according to an embodiment of the present invention.

FIG. 6C illustrates a top perspective view of the slide 620 of the vacuum seal lid 600, according to an embodiment of the present invention. A top face of the slide 620 may comprise a barrier 626 that may be provided to enable the user of the cylindrical container 100 to easily slide the slide 620 across the cavity present on the flat top portion 602 of the vacuum seal lid 600, according to an embodiment of the present invention.

FIG. 7 illustrates a cross sectional view of an open top lid 700 to be used as the top lid of the cylindrical container 100, according to an embodiment of the present invention. The open top lid 700 may comprise a body 702 that may be designed to be screwed onto the exterior thread 208 of the main body 102 for assembling the cylindrical container 100, in an embodiment of the present invention. According to embodiments of the present invention, the body 702 may be made up of a material such as, but not limited to, a plastic, wood, a metal, and so forth. Embodiments of the present invention are intended to include or otherwise cover any type of the material for making the body 702, including known, related art, and/or later developed technologies. Further, the body 702 may be designed in a plurality of colors such as, but not limited to, a red, a blue, a green, and so forth. Embodiments of the present invention are intended to include or otherwise cover any color for the body 702, including known, related art, and/or later developed colors. Furthermore, the body 702 of the open top lid 700 may comprise a thread 704 on an inner surface that may be provided to engage with the exterior thread 208 of the main body 102 when the open top lid 700 is screwed onto the main body 102 for assembling the cylindrical container 100, according to an embodiment of the present invention. In an embodiment of the present invention, the body 702 of the open top lid 700 may comprise a rounded top portion 706 that may be provided to reach over the lip 210 of the main body 102 to provide a flush look to the cylindrical container 100. Further, the body 702 may form a lip 708 at a bottom end of the body 702 that may be provided to accept the top panel lip 308 of the side panels 104 (as shown in the FIG. 3A), according to an embodiment of the present invention. According to an embodiment of the present invention, a total height of the open top lid 700 may be 13 Millimeters (mm). Further, a height of the lip 708 may be 3 mm and a width of the lip 708 may be 1 mm. In an embodiment of the present invention, a total width of the body 702 may be 3 mm and further a width of the thread 704 may be 1 mm.

FIG. 8A illustrates a perspective view of the screw lid 800, according to an embodiment of the present invention. The screw lid 800 may be used as the top lid that may be screwed onto the top end 202 of the main body 102 for assembling a cylindrical container 900 (as shown in FIG. 9A), in an embodiment of the present invention. According to an embodiment of the present invention, the screw lid 800 may comprise a flat top 802, a vertical ring 804, and a drinking lip 806. Further, the flat top 802, the vertical ring 804, and the drinking lip 806 may be made up of a material such as, but not limited to, a plastic, a natural rubber, a synthetic rubber, a metal, wood, and so forth. Embodiments of the present invention are intended to include or otherwise cover any type of the material for making the flat top 802, the vertical ring 804, and the drinking lip 806, including known, related art, and/or later developed technologies. In

14

an embodiment of the present invention, the flat top 802, the vertical ring 804, and the drinking lip 806 may be fabricated as a single piece. In another embodiment of the present invention, the flat top 802, the vertical ring 804, and the drinking lip 806 may be fabricated as a plurality of discrete pieces that may be attached together to form the screw lid 800. Further, the flat top 802, the vertical ring 804, and the drinking lip 806 may be designed in a plurality of colors such as, but not limited to, a red, a blue, a green, and so forth. Embodiments of the present invention are intended to include or otherwise cover any color for the flat top 802, the vertical ring 804, and the drinking lip 806, including known, related art, and/or later developed colors.

According to an embodiment of the present invention, the flat top 802 may further comprise a cavity 808 that may form an opening for accepting the slide 620 (as show in the FIG. 6B) to seal a drinking hole 810 and the opening when the cylindrical container 900 is not in use. In an embodiment of the present invention, the drinking hole 810 may allow the user of the cylindrical container 900 to easily sip the beverage contained in the cylindrical container 900. According to an embodiment of the present invention, the drinking hole 810 may be a semi-oval shaped drinking hole that may be capable of holding a straw (not shown). Further, the slide 620 may be capable of closing the drinking hole 810 completely when the user slides the slide 620 above the drinking hole 810 and fits the slide 620 into an indent 812 present in the drinking lip 806, thus covering the drinking hole 810 and restricting the flow of the beverage out of the cylindrical container 900, according to an embodiment of the present invention.

FIG. 8B illustrates a bottom perspective view of the screw lid 800, according to an embodiment of the present invention. The vertical ring 804 of the screw lid 800 may comprise an exterior wall 814, and an interior wall 816. Further, the exterior wall 814 and the interior wall 816 may extend vertically upwards from the flat top 802 to form a pocket 818, according to an embodiment of the present invention. In an embodiment of the present invention, the exterior wall 814 may have a height that may be greater than a height of the interior wall 816. Further, the pocket 818 may be provided to accept the top panel lip 308 of the side panels 104 (as shown in the FIG. 3A) for assembling the cylindrical container 900, in an embodiment of the present invention. According to an embodiment of the present invention, an outer surface of the interior wall 816 of the screw lid 800 may comprise an interior thread 820 that may be used to screw the screw lid 800 onto the interior thread 212 of the lip 210 of the main body 102 for assembling the cylindrical container 900. According to another embodiment of the present invention, an inner surface of the exterior wall 814 of the screw lid 800 may comprise an exterior thread 822 that may be used to screw the screw lid 800 onto the exterior thread 208 of the main body 102 for assembling the cylindrical container 100.

FIG. 8C illustrates a cross sectional view of the drinking lip 806 of the screw lid 800, according to an embodiment of the present invention. The drinking lip 806 may be provided to enable the user of the cylindrical container 900 to easily sip the beverage contained in the cylindrical container 900, according to an embodiment of the present invention. The drinking lip 806 may be an angled elevated boundary attached to the flat top 802 of the screw lid 800 that may wrap around a perimeter of the screw lid 800 (as shown in the FIG. 8A).

FIG. 8D illustrates a front view of the screw lid 800, according to an embodiment of the present invention. The

screw lid **800** may be used as the top lid that may be screwed onto the top end **202** of the main body **102** for assembling the cylindrical container **900**, in an embodiment of the present invention. According to an embodiment of the present invention, the screw lid **800** comprises the flat top **802**, the vertical ring **804**, and the drinking lip **806** as discussed in conjunction with the FIG. **8A** and the FIG. **8B**.

FIG. **8E** illustrates a cross sectional view of the screw lid **800**, according to an embodiment of the present invention. The screw lid **800** comprises the flat top **802**, the vertical ring **804**, and the drinking lip **806**. The drinking lip **806** may be attached to the flat top **802** that may be provided to enable the user of the cylindrical container **900** to easily sip the beverage contained in the cylindrical container **900**, according to an embodiment of the present invention. The vertical ring **804** of the screw lid **800** may comprise the exterior wall **814**, and the interior wall **816**. In an embodiment of the present invention, the exterior wall **814** may have a height greater than a height of the interior wall **816**.

FIGS. **9A-9B** illustrate different views of the assembled cylindrical container **900** using the screw lid **800**, according to an embodiment of the present invention.

FIG. **9A** illustrates a front view of the assembled cylindrical container **900**, according to an embodiment of the present invention. The cylindrical container **900** may be a cylindrically shaped container designed to hold the beverage. According to embodiments of the present invention, the cylindrical container **900** comprises the main body **102** (as shown in the FIG. **2A**), the side panels **104**, the bottom lid **106**, and the screw lid **800** to be used as the top lid for sealing the cylindrical container **900**. Further, to assemble the cylindrical container **900**, the main body **102**, the side panels **104**, the bottom lid **106** and the screw lid **800** may be attached to one another as discussed above, according to an embodiment of the present invention. In an embodiment of the present invention, the cylindrical container **900** may have an O-ring or a ring adapter (not shown) to hold the side panels **104**. The ring adapter may be a simple ring that rests on the side panels **104** when the side panels **104** may be attached to the cylindrical container **900**. The ring adapter may have threads on the inside of the ring, in an embodiment of the present invention. The ring having threads on the inside of the ring may be used for a cylindrical container having threads on an outside of the lip. In another embodiment of the present invention, the ring adapter may have threads on the outside of the ring. The ring having threads on the outside of the ring may be used for a cylindrical container having threads on an inside of the lip.

FIG. **9B** illustrates a side perspective view of the assembled cylindrical container **900**, according to an embodiment of the present invention. The cylindrical container **900** comprises the main body **102**, the side panels **104**, the bottom lid **106**, and the screw lid **800** to be used as the top lid for sealing the cylindrical container **100**.

FIG. **9C** illustrates a cross sectional view of the assembled cylindrical container **900** using the screw lid **800**, according to an embodiment of the present invention. The cylindrical container **900** may be assembled by connecting the side panels **104** with each other forming the insulating cover for the main body **102**. Further, the bottom lid **106** may be screwed onto the main body **102**. Furthermore, the bottom panel lip **310** of the side panels **104** may be inserted into the bottom lid pocket **406** (as shown in the FIG. **9D**). Furthermore, the screw lid **800** may be screwed onto the lip **210** of the main body **102** such that the pocket **818** (as shown in the FIG. **8B**) formed between the exterior wall **814** and the

interior wall **816** of the screw lid **800** accepts the top panel lip **308** of the side panels **104**, in an embodiment of the present invention.

FIG. **9D** illustrates another cross sectional view of the assembled cylindrical container **900** using the screw lid **800**, according to an embodiment of the present invention. The cylindrical container **900** may be assembled by connecting the side panels **104** with each other forming the insulating cover for the main body **102**. Further, the bottom lid **106** may be screwed onto the main body **102**. Furthermore, the bottom panel lip **310** of the side panels **104** may be inserted into the bottom lid pocket **406** formed between the exterior wall **402** and the interior wall **404** of the bottom lid **106**. Furthermore, the screw lid **800** may be screwed onto the main body **102** such that the pocket **818** (as shown in the FIG. **8B**) formed between the exterior wall **814** and the interior wall **816** of the screw lid **800** accepts the top panel lip **308** of the side panels **104** (as shown in the FIG. **9C**).

FIG. **9E** illustrates a perspective view of a ring adapter **902**, according to an embodiment of the present invention. The ring adapter **902** may be screwed onto the exterior thread **208** provided along the outer surface of the side wall **200** of the main body **102** (as shown in the FIG. **2A**). Further, the ring adapter **902** may rest over the side panels **104** (as shown in the FIG. **3A**) when the side panels **104** are installed onto the main body **102** for assembling the cylindrical container **100**. According to an embodiment of the present invention, the ring adapter **902** may comprise a wall **904** that may form a circular rigid structure for the ring adapter **902**. Further, an upper end and a lower end of the wall **904** may be flat such that the ring adapter **904** wraps around an outer surface of the main body **102**. According to an embodiment of the present invention, the wall **904** may be made up of a material such as, but not limited to, a plastic, a metal, wood, and so forth. Embodiments of the present invention are intended to include or otherwise cover any type of the material for the wall **904**, including known, related art, and/or later developed technologies. Furthermore, the wall **904** may be designed in different colors such as, but not limited to, a red, a blue, a green, and so forth. Embodiments of the present invention are intended to include or otherwise cover any color for the wall **904**, including known, related art, and/or later developed colors. According to an embodiment of the present invention, an inner surface of the wall **904** may comprise a thread **906** that may be capable of engaging with the exterior thread **208** of the main body **102** while screwing the ring adapter **902** onto the main body **102** for assembling the cylindrical container **100**.

FIG. **9F** illustrates a perspective view of a ring adapter **908**, according to another embodiment of the present invention. The ring adapter **908** may be screwed onto the interior thread **212** provided on the lip **210** of the main body **102** (as shown in the FIG. **2A**). Further, the ring adapter **908** may be used to cover the interior thread **212** such that the ring portion **604** of the vacuum seal lid **600** (as shown in the FIG. **6A**) may form the vacuum seal with the inner surface of the ring adapter **908** when the vacuum seal lid **600** is pushed into the opening **206** of the main body **102** (as shown in the FIG. **2A**). According to an embodiment of the present invention, the ring adapter **908** may comprise a wall **910** that may form a circular rigid structure for the ring adapter **908**. Further, an upper end and a lower end of the wall **910** may be flat such that the ring adapter **910** wraps around an inner surface of the lip **210** of the main body **102**. According to an embodiment of the present invention, the wall **910** may be made up of a material such as, but not limited to, a plastic, a metal,

wood, and so forth. Embodiments of the present invention are intended to include or otherwise cover any type of the material for the wall **910**, including known, related art, and/or later developed technologies. Furthermore, the wall **910** may be designed in different colors such as, but not limited to, a red, a blue, a green, and so forth. Embodiments of the present invention are intended to include or otherwise cover any color for the wall **910**, including known, related art, and/or later developed colors. According to an embodiment of the present invention, an outer surface of the wall **910** may comprise a thread **912** that may be capable of engaging with the interior thread **212** of the lip **210** of the main body **102** while screwing the ring adapter **908** onto the main body **102** for assembling the cylindrical container **100**.

FIG. **10A** illustrates an exploded view of a cylindrical container **1000**, according to another embodiment of the present invention. The cylindrical container **1000** comprises a main body **1002**, a plurality of side panels **1004a-1004b** (hereinafter referred to as the side panels **1004**), the bottom lid **106** (as shown in the FIG. **4A**), and the screw lid **800** (as shown in the FIG. **8A**) that may be used as a top lid for sealing the cylindrical container **1000**. Further, to assemble the cylindrical container **1000**, the main body **1002**, the side panels **1004**, the bottom lid **106**, and the screw lid **800** may be attached to one another, according to an embodiment of the present invention.

The main body **1002** may be a cylindrical shaped enclosed structure designed to hold a beverage or a solid material. Further, a size of the main body **1002** may be designed such that a beverage holding capacity and/or a solid material holding capacity of the main body **1002** may be, but not limited to, 8 ounces, 16 ounces, 64 ounces, and so forth. Embodiments of the present invention are intended to include or otherwise cover any of the size of the main body **1002**. Further, the main body **1002** may be made up of a material such as, but not limited to, a plastic, a metal, wood, and so forth. Embodiments of the present invention are intended to include or otherwise cover any type of the material for the main body **1002**, including known, related art, and/or later developed technologies. Further, the main body **1002** will be explained in detail in conjunction with FIG. **10B**.

The side panels **1004** may have a semi-cylindrical shape that may be attached to one another forming a cover for the main body **1002** for a customization and/or a personalization of the cylindrical container **1000**, according to an embodiment of the present invention. Further, the side panels **1004** may be made up of a transparent material such as, but not limited to, a plastic, a rubber, a Polyvinyl Chloride (PVC), an acrylic, a polycarbonate, and so forth. Embodiments of the present invention are intended to include or otherwise cover any type of the transparent material for making the side panels **1004**, including known, related art, and/or later developed technologies. Further, the side panels **1004** will be explained in detail in conjunction with FIG. **10C**.

The bottom lid **106** may be designed to be screwed onto the main body **1002** for assembling the cylindrical container **1000**, according to an embodiment of the present invention. The bottom lid **106** may comprise the bottom surface **400**, the exterior wall **402**, and the interior wall **404**, as discussed above in conjunction with the FIG. **4A**. The screw lid **800** may be used as the top lid that may be screwed onto the main body **1002** for assembling the cylindrical container **1000**, in an embodiment of the present invention. According to an embodiment of the present invention, the screw lid **800** may comprise the flat top **802**, the vertical ring **804**, and the drinking lip **806**, as discussed above in conjunction with the

FIG. **8A**. According to an embodiment of the present invention, the screw lid **800** may comprise the cavity **808** (as shown in the FIG. **8A**) that may form an opening for accepting the slide **620** (as show in the FIG. **6B**) to seal the drinking hole **810** and the opening when the cylindrical container **1000** is not in use. According to an embodiment of the present invention, the top face of the slide **620** may comprise one or more barriers **1005a-1005n** (hereinafter referred to as the barriers **1005**) that may be provided to enable the user of the cylindrical container **1000** to easily slide the slide **620** across the cavity **808** of the screw lid **800**, according to an embodiment of the present invention.

FIG. **10B** illustrates a side perspective view of the main body **1002** of the cylindrical container **1000**, according to an embodiment of the present invention. The main body **1002** may comprise a side wall **1006**, a top end **1008**, and a bottom end **1010**, in an embodiment of the present invention. Further, the main body **1002** may comprise a top thread **1012** along an outer surface of the side wall **1006** near the top end **1008**. The top thread **1012** may be designed such that the side panels **1004** may rest under the top thread **1012** while assembling the cylindrical container **1000**, in an embodiment of the present invention. Furthermore, the main body **1002** may comprise a bottom thread **1014** along an outer surface of the side wall **1006** near the bottom end **1010**. The bottom thread **1014** may be designed such that the side panels **1004** may rest above the bottom thread **1014** while assembling the cylindrical container **1000**, in an embodiment of the present invention.

According to an embodiment of the present invention, the main body **1002** may comprise a plurality of top male detents **1016a-1016d** (hereinafter referred to as the top male detents **1016**) on the side wall **1006** near the top thread **1012** and a plurality of bottom male detents **1018a-1018d** (hereinafter referred to as the bottom male detents **1018**) on the side wall **1006** near the bottom thread **1014**. The top male detents **1016** and the bottom male detents **1018** may be provided to engage with the side panels **1004** for fixedly holding the side panels **1004** in place and eliminating a rotation of the side panels **1004** when the screw lid **800** is not attached to the main body **1002**. In an embodiment of the present invention, the top male detents **1016** and the bottom male detents **1018** may be a protrusion that may be integrally fabricated within the main body **1002**. In another embodiment of the present invention, the top male detents **1016** and the bottom male detents **1018** may be externally attached to the main body **1002**.

FIG. **10C** illustrates the side panels **1004** of the cylindrical container **1000**, according to an embodiment of the present invention. The side panels **1004** comprises a body **1020**, a top edge **1022**, and a bottom edge **1024**. Further, the body **1020** may comprise a cutout **1026** on an inner surface of the side panels **1004**, which may act as a frame to fixedly hold an item. The item may be for example, but not limited to, a business card, a photograph, a printed design, and so forth, which may be used for advertisement purposes, entertainment purposes, etc. Embodiments of the present invention are intended to include or otherwise cover any of the item to be fixedly held within the cutout **1026**, including known, related art, and/or later developed technologies. The cutout **1026** may be a pocket that may be fixedly attached to the inner surface of the body **1020**, in an embodiment of the present invention. In another embodiment of the present invention, the cutout **1026** may be removably attached to the inner surface of the body **1020**. Further, the cutout **1026** may be made up of a material such as, but not limited to, a plastic, a rubber, a Polyvinyl Chloride (PVC), an acrylic, a poly-

carbonate, and so forth. Embodiments of the present invention are intended to include or otherwise cover type of the material for making the cutout 1026, including known, related art, and/or later developed technologies. According to another embodiment of the present invention, the side panels 1004 may be designed in a plurality of colors such as, but not limited to, a red, a blue, a green, a black, a white, and so forth. Embodiments of the present invention are intended to include or otherwise cover any of the color for the side panels 1004, including known, related art, and/or later developed technologies.

In an embodiment of the present invention, the side panels 1004 may comprise a default pattern printed on an outer surface of the body 1020. The default pattern may be, but not limited to, a picture, a design, and so forth. Embodiments of the present invention are intended to include or otherwise cover any of the default pattern printed onto the outer surface of the side panels 1004, including known, related art, and/or later developed technologies. According to an embodiment of the present invention, the side panels 1004 may be attached to the main body 1002 of the cylindrical container 1000 to provide an insulation to a user holding the cylindrical container 1000 containing a hot beverage and/or a cold beverage. Further, the side panels 1004 may provide an insulation to the beverage stored in the main body 1002 of the cylindrical container 1000 from outside environment that may slow down a heating rate and/or a cooling rate of the beverage inside the cylindrical container 1000.

According to an embodiment of the present invention, the side panels 1004 may comprise a top panel lip 1028 near the top edge 1022 along the body 1020 and a bottom panel lip 1030 near the bottom edge 1024 along the body 1020. Further, a thickness of the top panel lip 1028 and a thickness of the bottom panel lip 1030 may be less than a thickness of the body 1020 of the side panels 1004. According to an embodiment of the present invention, the side panels 1004 may comprise a top male alignment feature 1032, a top female alignment feature 1034, a bottom male alignment feature 1036, a bottom female alignment feature 1038. The top male alignment feature 1032 and the top female alignment feature 1034 may be provided near a bottom end of the top panel lip 1028. Further, the bottom male alignment feature 1036 and the bottom female alignment feature 1038 may be provided near a top end of the bottom panel lip 1030, according to an embodiment of the present invention. Further, the side panels 1004 may comprise a top full ply groove 1040, a plurality of top half ply grooves 1042a-1042b (hereinafter referred to as the top half ply grooves 1042), a bottom full ply groove 1046, a plurality of bottom half ply grooves 1048a-1048b (hereinafter referred to as the bottom half ply grooves 1048), in an embodiment of the present invention. The top half ply grooves 1042 may be designed to form a ply groove that may be similar to the top full ply groove 1040 when the side panels 1004 are attached to each another, according to an embodiment of the present invention. Further, the bottom half ply grooves 1048 may be designed to form a ply groove that may be similar to the bottom full ply groove 1046 when the side panels 1004 are attached to each another, according to an embodiment of the present invention. The top full ply groove 1040 and the ply groove formed by the top half ply grooves 1042 may be provided to engage with the top male detents 1016 of the main body 1002. Further, the bottom full ply groove 1046 and the ply groove formed by the bottom half ply grooves 1048 may be provided to engage with the bottom male detents 1018 of the main body 1002, according to an embodiment of the present invention.

FIG. 10D illustrates a partial assembled view of the cylindrical container 1000, according to an embodiment of the present invention. The cylindrical container 1000 may be assembled by attaching the side panels 1004 with each other using the top male alignment feature 1032 of the first side panel 1004 that may be inserted into the top female alignment feature 1034 of the second side panel 1004, in an embodiment of the present invention. Further, the attachment of the side panels 1004 may result in engagement of the top male detents 1016 within the top ply groove 1040 and the ply groove formed by the top half ply grooves 1042 of each of the side panels 1004 attached together that may eliminate the rotational movement of the side panels 1004, according to an embodiment of the present invention.

FIG. 10E illustrates the top male alignment feature 1032 of the side panels 1004 enclosing the main body 1002 of the cylindrical container 1000, according to an embodiment of the present invention. The top male alignment feature 1032 may be a tapered cylindrical protrusion extending in an outward direction from a top side of the side panels 1004, according to embodiments of the present invention. In an embodiment of the present invention, the bottom male alignment feature 1036 (as shown in the FIG. 10C) may have a similar structure as the top male alignment feature 1032. According to an embodiment of the present invention, a diameter of the top male alignment feature 1032 and the bottom male alignment feature 1036 may be larger at an end attached to the side panels 1004 than a diameter at an end that may be inserted into the top female alignment feature 1034 and the bottom female alignment feature 1038 (as shown in the FIG. 10C) of the second side panel 1004, respectively. Further, the top male alignment feature 1032 and the bottom male alignment feature 1036 may be integrally fabricated with the side panels 1004, in an embodiment of the present invention. In another embodiment of the present invention, the top male alignment feature 1032 and the bottom male alignment feature 1036 may be externally attached to the side panels 1004.

FIG. 10F illustrates the top female alignment feature 1034 of the side panels 1004 enclosing the main body 1002 of the cylindrical container 1000, according to an embodiment of the present invention. The top female alignment feature 1034 may be a tapered hole provided at a top side of the side panels 1004 that may be aligned with the top male alignment feature 1032 of the second side panel 1004, according to embodiments of the present invention. In an embodiment of the present invention, the bottom female alignment feature 1038 (as shown in the FIG. 10C) may have a similar structure as the top female alignment feature 1034. According to an embodiment of the present invention, a diameter of the top female alignment feature 1034 and the bottom female alignment feature 1038 may be larger at a top end than a diameter at a bottom end such that the top female alignment feature 1034 and the bottom female alignment feature 1038 may accept the top male alignment feature 1032 and the bottom male alignment feature 1036 (as shown in the FIG. 10C) of the second side panel 1004 respectively.

FIG. 10G illustrates another partial view of the cylindrical container 1000 with the side panels 1004 attached to the main body 1002, according to an embodiment of the present invention. The cylindrical container 1000 may be assembled by attaching the side panels 1004 with each other by using the top male alignment feature 1032 of the first side panel 1004 that may be inserted into the top female alignment feature 1034 of the second side panel 1004 for fixedly attaching the side panels 1004 together onto the main body 1002, in an embodiment of the present invention.

FIG. 10H illustrates a cross sectional view of the assembled cylindrical container 1000, according to an embodiment of the present invention. The cylindrical container 1000 may be assembled by attaching the main body 1002, the side panels 1004, the bottom lid 106, and the screw lid 800 to one another, according to an embodiment of the present invention. The bottom lid 106 may be designed to be screwed onto the bottom thread 1014 provided along the outer surface of the side wall 1006 near the bottom end 1010 of the main body 1002 for assembling the cylindrical container 1000, in an embodiment of the present invention. Further, the bottom lid 106 may be screwed onto the top thread 1012 provided along the outer surface of the side wall 1006 near the top end 1008 of the main body 1002 fully enclosing the cylindrical container 1000, according to another embodiment of the present invention. Furthermore, the side panels 1004 may be attached to each other by aligning the top male alignment feature 1032, the top female alignment feature 1034, the bottom male alignment feature 1036 and the bottom female alignment feature 1038 of the first side panel 1004 with the top male alignment feature 1032, the top female alignment feature 1034, the bottom male alignment feature 1036 and the bottom female alignment feature 1038 of the second side panel 1004 and pushing the side panels 1004 against each other for fixedly attaching the side panels 1004 together thus enclosing the main body 1002 of the cylindrical container 1000, according to an embodiment of the present invention.

FIG. 11 illustrates a cross sectional view of a cylindrical container 1100 to be used as a jar, according to an embodiment of the present invention. The cylindrical container 1100 may be designed to hold a beverage, in an embodiment of the present invention. The beverage may be, but not limited to, water, coffee, tea, juice, and so forth. Embodiments of the present invention are intended to include or otherwise cover any type of the beverage, including known, related art, and/or later developed beverages. In another embodiment of the present invention, the cylindrical container 1100 may be designed to hold a solid material, such as, but not limited to, a cooking powder, a seasoning, a bead, a craft item, and so forth. Embodiments of the present invention are intended to include or otherwise cover any type of the solid material, including known, related art, and/or later developed solid materials. Further, the cylindrical container 1100 may comprise a main body 1102, a plurality of side panels 1104a-1104b (hereinafter referred to as the side panels 1104), a top lid 1106a, and a bottom lid 1106b.

The main body 1102 of the cylindrical container 1100 may be a cylindrical shaped enclosed structure designed to hold the beverage and/or the solid material. Further, a size of the main body 1102 may be designed such that a beverage holding capacity and/or a solid material holding capacity of the main body 1102 may be, but not limited to, 8 ounces, 16 ounces, 64 ounces, and so forth. Embodiments of the present invention are intended to include or otherwise cover any of the size of the main body 1102. Further, the main body 1102 may be made up of a material such as, but not limited to, a plastic, a metal, wood, and so forth. Embodiments of the present invention are intended to include or otherwise cover any type of the material for the main body 1102, including known, related art, and/or later developed technologies. The main body 1102 may comprise a top thread 1108 provided along an outer surface near a top end 1110 of the main body 1102 and a bottom thread 1112 provided along the outer surface near a bottom end 1114 of the main body 1102, according to an embodiment of the present invention. In an

embodiment of the present invention, the main body 1102 may be designed similar to a structure of the main body 102 (as shown in the FIG. 2A). In another embodiment of the present invention, the main body 1102 may be designed similar to a structure of the main body 1002 (as shown in the FIG. 10A).

The side panel 1104a may have a semi-cylindrical shape that may be attached to a second side panel 1104b forming a cover for the main body 1102 for a customization and/or a personalization of the cylindrical container 1100, according to an embodiment of the present invention. Further, the side panels 1104 may be made up of a transparent material such as, but not limited to, a plastic, a rubber, a Polyvinyl Chloride (PVC), an acrylic, a polycarbonate, and so forth. Embodiments of the present invention are intended to include or otherwise cover any type of the transparent material for making the side panels 1104, including known, related art, and/or later developed technologies. In an embodiment of the present invention, the side panel 1104 may be designed similar to a structure of the side panel 104 (as shown in the FIG. 3A). In another embodiment of the present invention, the side panel 1104 may be designed similar to a structure of the side panel 1004 (as shown in the FIG. 10C).

The top lid 1106a may be designed to be screwed onto the top thread 1108 provided along the outer surface near the top end 1110 of the main body 1102 for assembling the cylindrical container 1100, in an embodiment of the present invention. Further, the bottom lid 1106b may be designed to be screwed onto the bottom thread 1112 provided along the outer surface near the bottom end 1114 of the main body 1102 for fully enclosing the cylindrical container 1100 to be used as the jar for holding the beverage and/or the solid material. According to an embodiment of the present invention, the top lid 1106a may comprise a top surface 1116, and an exterior wall 1118. The top surface 1116, and the exterior wall 1118 may be made up of a material such as, but not limited to, a plastic, wood, a metal, and so forth. Embodiments of the present invention are intended to include or otherwise cover any type of the material for making the top surface 1116, and the exterior wall 1118 including known, related art, and/or later developed technologies. Furthermore, the top surface 1116, and the exterior wall 1118 may be designed in a plurality of colors such as, but not limited to, a red, a blue, a green, and so forth. Embodiments of the present invention are intended to include or otherwise cover any color for the top surface 1116, and the exterior wall 1118, including known, related art, and/or later developed colors. According to an embodiment of the present invention, the top surface 1116 may be a flat platform that may act as a rigid support for the exterior wall 1118 that may be fixedly attached onto the top surface 1116. According to an embodiment of the present invention, an inner surface of the exterior wall 1118 may comprise a top lid thread 1120 that may be used to screw the top lid 1106a onto the top thread 1108 of the main body 1102.

According to an embodiment of the present invention, the bottom lid 1106b may comprise a bottom surface 1122, and an exterior wall 1124. The bottom surface 1122, and the exterior wall 1124 may be made up of a material such as, but not limited to, a plastic, wood, a metal, and so forth. Embodiments of the present invention are intended to include or otherwise cover any type of the material for making the bottom surface 1122, and the exterior wall 1124 including known, related art, and/or later developed technologies. Furthermore, the bottom surface 1122, and the exterior wall 1124 may be designed in a plurality of colors

such as, but not limited to, a red, a blue, a green, and so forth. Embodiments of the present invention are intended to include or otherwise cover any color for the bottom surface **1122**, and the exterior wall **1124**, including known, related art, and/or later developed colors. According to an embodiment of the present invention, the bottom surface **1122** may be a flat platform that may act as a rigid support for the exterior wall **1124** that may be fixedly attached onto the bottom surface **1122**. According to an embodiment of the present invention, an inner surface of the exterior wall **1124** may comprise a bottom lid thread **1126** that may be used to screw the bottom lid **1106b** onto the bottom thread **1112** of the main body **1102**.

FIG. 12 illustrates a flowchart of a method **1100** for assembling the cylindrical container **100**, according to an embodiment of the present invention. At step **1202**, the user may connect the side panels **104** with one another forming the insulating cover for the main body **102** of the cylindrical container **100**.

At step **1204**, the user may screw the bottom lid **106** from the bottom end **204** of the main body **102**.

Further, at step **1206**, the user may insert the item inside the cutout **306** of the side panels **104**. The item may be, but not limited to, a photograph, a business card, a printed design, and so forth.

At step **1208**, the user may insert the bottom panel lip **310** of the side panels **104** into the bottom lid pocket **406** formed between the exterior wall **402** and the interior wall **404** of the bottom lid **106**.

At step **1210**, the user may screw the standard lid **108** onto the top end **202** of the main body **102** such that the top panel lip **308** of the side panels **104** engages within the top lid pocket **506** formed between the exterior wall **500** and the interior wall **502** of the standard lid **108**.

At step **1212**, the user may insert and push the vacuum seal lid **600** through the opening **206** of the main body **102** such that the O-ring inserted into the O-ring hole **616** presses against the inner surface of the interior wall **502** of the standard lid **108** resulting in the vacuum seal for the cylindrical container **100**.

The present invention, in various embodiments, configurations, and aspects, includes components, methods, processes, systems and/or apparatus substantially as depicted and described herein, including various embodiments, sub-combinations, and subsets thereof. Those of skill in the art will understand how to make and use the present invention after understanding the present disclosure.

The present invention, in various embodiments, configurations, and aspects, includes providing devices and processes in the absence of items not depicted and/or described herein or in various embodiments, configurations, or aspects hereof, including in the absence of such items as may have been used in previous devices or processes, e.g., for improving performance, achieving ease and/or reducing cost of implementation.

While the foregoing is directed to embodiments of the present disclosure, other and further embodiments of the present disclosure may be devised without departing from the basic scope thereof. It is understood that various embodiments described herein may be utilized in combination with any other embodiment described, without departing from the scope contained herein. Further, the foregoing description is not intended to be exhaustive or to limit the disclosure to the precise form disclosed.

Modifications and variations are possible in light of the above teachings or may be acquired from practice of the disclosure. Certain exemplary embodiments may be identi-

fied by use of an open-ended list that includes wording to indicate that the list items are representative of the embodiments and that the list is not intended to represent a closed list exclusive of further embodiments. Such wording may include “e.g.,” “etc.,” “such as,” “for example,” “and so forth,” “and the like,” etc., and other wording as will be apparent from the surrounding context.

What is claimed is:

1. A cylindrical container comprising:

a main body to store a beverage or a solid material, wherein the main body comprising a top end and a bottom end;

a plurality of side panels, attached to one another, to form an insulated cover around the main body, wherein each of the plurality of side panels comprises a top panel lip and a bottom panel lip, and wherein an inner surface of each of the side panels has a cutout in which to hold an item for display through the respective side panel;

a bottom lid, having an exterior wall, an interior wall, and a bottom lid pocket between the exterior wall and the interior wall configured to receive the bottom panel lips of the side panels and an extended bottom wall provided at the bottom end of the main body, wherein a height of the exterior wall is greater than a height of the interior wall, and wherein an outer surface of the interior wall comprises a bottom lid thread to be screwed onto a bottom thread of the extended bottom wall provided at the bottom end of the main body;

a standard lid, having an exterior wall and an interior wall, wherein an outer surface of the interior wall comprises an interior lid thread to be screwed onto an interior thread of a lip provided at the top end of the main body; and

a vacuum seal lid, having a flat top portion and a ring portion, wherein the ring portion comprises an O-ring hole along a circumference of the ring portion for accepting an O-ring to create a vacuum seal.

2. The container of claim 1, wherein the top panel lip of each of the plurality of side panels is inserted into a top lid pocket formed between the exterior wall and the interior wall of the standard lid.

3. The container of claim 1, wherein the cutouts are configured to hold an item selected from one of, a business card, a photograph, a printed design, or a combination thereof.

4. The container of claim 1, wherein an inner surface of the exterior wall of the standard lid comprises an exterior lid thread to be screwed onto an exterior thread provided at the top end of the main body.

5. The container of claim 1, wherein the bottom lid forms a small compartment between the bottom end of the main body and a bottom surface of the bottom lid when the bottom lid is screwed onto the main body.

6. The container of claim 1, wherein a height of the exterior wall of the standard lid is greater than a height of the interior wall of the standard lid.

7. The container of claim 1, wherein the flat top portion of the vacuum seal lid comprises a cavity for accepting a slide to close a drinking hole provided on the flat top portion of the vacuum seal lid.

8. The container of claim 7, wherein the slide comprises a plurality of clips to be snapped and engaged into the cavity of the flat top portion.

9. The container of claim 7, wherein the slide comprises an air hole to allow a passage of air into the cylindrical container for a smooth pour of the beverage.

25

10. The container of claim 7, wherein the slide comprises a barrier for sliding the slide across the cavity for opening and/or closing the drinking hole.

11. A cylindrical container comprising:

a main body, to store a beverage or a solid material, wherein the main body comprising a top end and a bottom end;

a plurality of side panels, attached to one another, to form an insulated cover around the main body, wherein each of the plurality of side panels comprises a top panel lip and a bottom panel lip, and wherein an inner surface of each of the side panels has a cutout in which to hold an item for display through the respective side panel;

a bottom lid, having an exterior wall, an interior wall, and a bottom lid pocket between the exterior wall and the interior wall configured to receive the bottom panel lips of the side panels and an extended bottom wall provided at the bottom end of the main body, wherein a height of the exterior wall is greater than a height of the interior wall, and wherein an outer surface of the interior wall comprises a bottom lid thread to be screwed onto a bottom thread of the extended bottom wall provided at the bottom end of the main body;

a standard lid, having an exterior wall and an interior wall such that a height of the exterior wall is greater than a height of the interior wall, wherein an outer surface of the interior wall comprises an interior lid thread to be screwed onto an interior thread of a lip provided at the top end of the main body, wherein an inner surface of the exterior wall of the standard lid comprises an exterior lid thread to be screwed onto an exterior thread provided at the top end of the main body; and

a vacuum seal lid, having a flat top portion and a ring portion, wherein the ring portion comprises an O-ring hole along a circumference of the ring portion for accepting an O-ring to create a vacuum seal.

12. The container of claim 11, wherein the top panel lip of each of the plurality of side panels is inserted into a top lid pocket formed between the exterior wall and the interior wall of the standard lid.

13. The container of claim 11, wherein the cutouts are configured to hold an item selected from one of, a business card, a photograph, a printed design, or a combination thereof.

14. The container of claim 11, wherein the bottom lid forms a small compartment between the bottom end of the main body and a bottom surface of the bottom lid when the bottom lid is screwed onto the main body.

15. The container of claim 11, wherein the flat top portion of the vacuum seal lid comprises a cavity for accepting a

26

slide such that the slide is used to close a drinking hole provided on the flat top portion of the vacuum seal lid.

16. The container of claim 15, wherein the slide comprises a plurality of clips to be snapped and engaged into the cavity of the flat top portion.

17. The container of claim 15, wherein the slide comprises an air hole to allow a passage of air into the cylindrical container for a smooth pour of the beverage.

18. The container of claim 15, wherein the slide comprises a barrier for sliding the slide across the cavity for opening and/or closing the drinking hole.

19. A method for assembling a cylindrical container, the method comprising steps of:

connecting a plurality of side panels with one another to form an insulated cover to be attached around a main body, wherein each of the plurality of side panels comprises a top panel lip and a bottom panel lip, and wherein an inner surface of each of the side panels has a cutout in which to hold an item for display through the respective side panel;

screwing a bottom lid with the main body, wherein the bottom lid comprises an exterior wall, an interior wall, a bottom lid pocket between the exterior wall and the interior wall configured to receive the bottom panel lips of the side panels and an extended bottom wall provided at the bottom end of the main body, and a bottom lid thread on an outer surface of the interior wall, which is screwed onto a bottom thread of the extended bottom wall provided at the bottom end of the main body;

inserting the bottom panel lip of each of the plurality of connected side panels and the extended bottom wall provided at the bottom end of the main body into the bottom lid pocket of the bottom lid;

screwing a standard lid, having an interior lid thread on an outer surface of an interior wall, onto an interior thread of a lip provided at a top end of the main body such that the top panel lip of each of the plurality of connected side panels is fixedly engaged within a top lid pocket of the standard lid; and

attaching a vacuum seal lid, by pushing the vacuum seal lid into an opening of the main body such that an O-ring held within an O-ring hole of the vacuum seal lid creates a vacuum seal against the interior wall of the standard lid.

20. The method of claim 19, further comprising inserting an item inside each cutout, wherein the item is selected from one of, a photograph, a business card, a printed design, or a combination thereof.

* * * * *