

(12) **United States Patent**
Williams et al.

(10) **Patent No.:** **US 11,086,188 B2**
(45) **Date of Patent:** **Aug. 10, 2021**

(54) **OPTICAL WAVEGUIDE MODULATOR**

(71) Applicant: **Elenion Technologies, LLC**, New York, NY (US)

(72) Inventors: **Christopher Williams**, Montreal (CA); **Mostafa Ahmed**, Urbana, IL (US); **Alexander Rylyakov**, Staten Island, NY (US); **Richard C. Younce**, Naperville, IL (US); **Yang Liu**, Elmhurst, NY (US); **Ran Ding**, New York, NY (US); **Abdelrahman Ahmed**, Brooklyn, NY (US)

(73) Assignee: **Nokia Solutions & Networks Oy**, Espoo (FI)

(*) Notice: Subject to any disclaimer, the term of this patent is extended or adjusted under 35 U.S.C. 154(b) by 0 days.

(21) Appl. No.: **16/734,539**

(22) Filed: **Jan. 6, 2020**

(65) **Prior Publication Data**

US 2020/0142274 A1 May 7, 2020

Related U.S. Application Data

(63) Continuation of application No. 16/202,818, filed on Nov. 28, 2018, now Pat. No. 10,558,104, which is a continuation of application No. 15/602,657, filed on May 23, 2017, now Pat. No. 10,168,596.

(51) **Int. Cl.**

G02F 1/225 (2006.01)
G02F 1/21 (2006.01)

(52) **U.S. Cl.**

CPC **G02F 1/2255** (2013.01); **G02F 1/2257** (2013.01); **G02F 1/212** (2021.01); **G02F 2201/122** (2013.01)

(58) **Field of Classification Search**

CPC . **G02F 2001/212**; **G02F 1/2255**; **G02F 1/2257**
See application file for complete search history.

(56) **References Cited**

U.S. PATENT DOCUMENTS

9,229,250 B2 * 1/2016 Minoia H03K 19/018521
9,939,667 B1 * 4/2018 El-Moznine G02F 1/2257

* cited by examiner

Primary Examiner — Omar R Rojas

(74) *Attorney, Agent, or Firm* — Stratford Managers Corporation

(57) **ABSTRACT**

A multi-section optical modulator and related method are disclosed wherein two waveguide arms traverse a plurality of successive modulating sections. A differential drive signal is applied separately to each waveguide arm of each modulating sections in synchronism with the transmission of light along the waveguide arms, affecting a dual differential driving of each section. By suitably selecting the number of modulating sections and the section length, a high modulation bandwidth and a high modulation efficiency may be achieved simultaneously for a given peak-to-peak voltage swing of the drive signal.

18 Claims, 17 Drawing Sheets

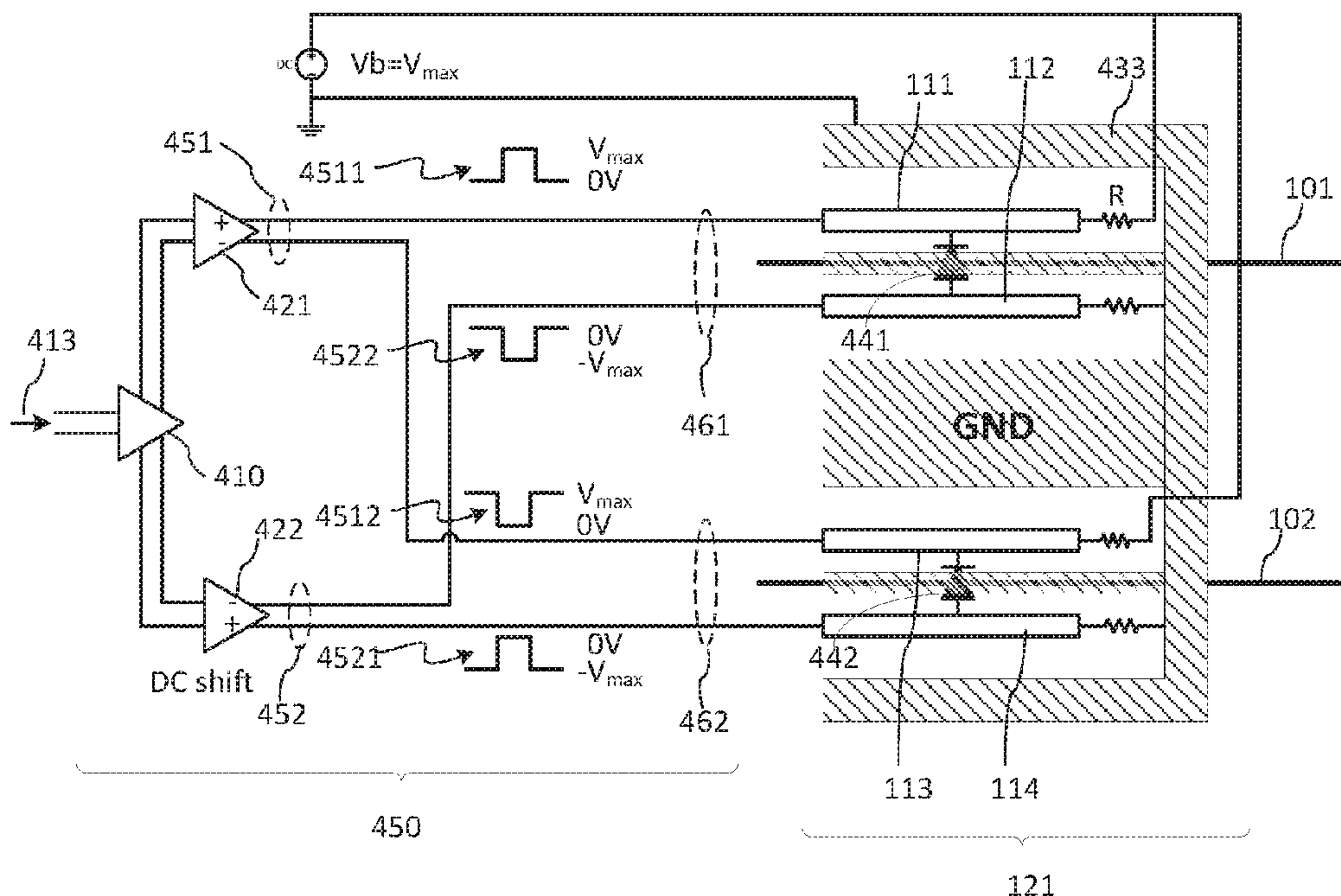

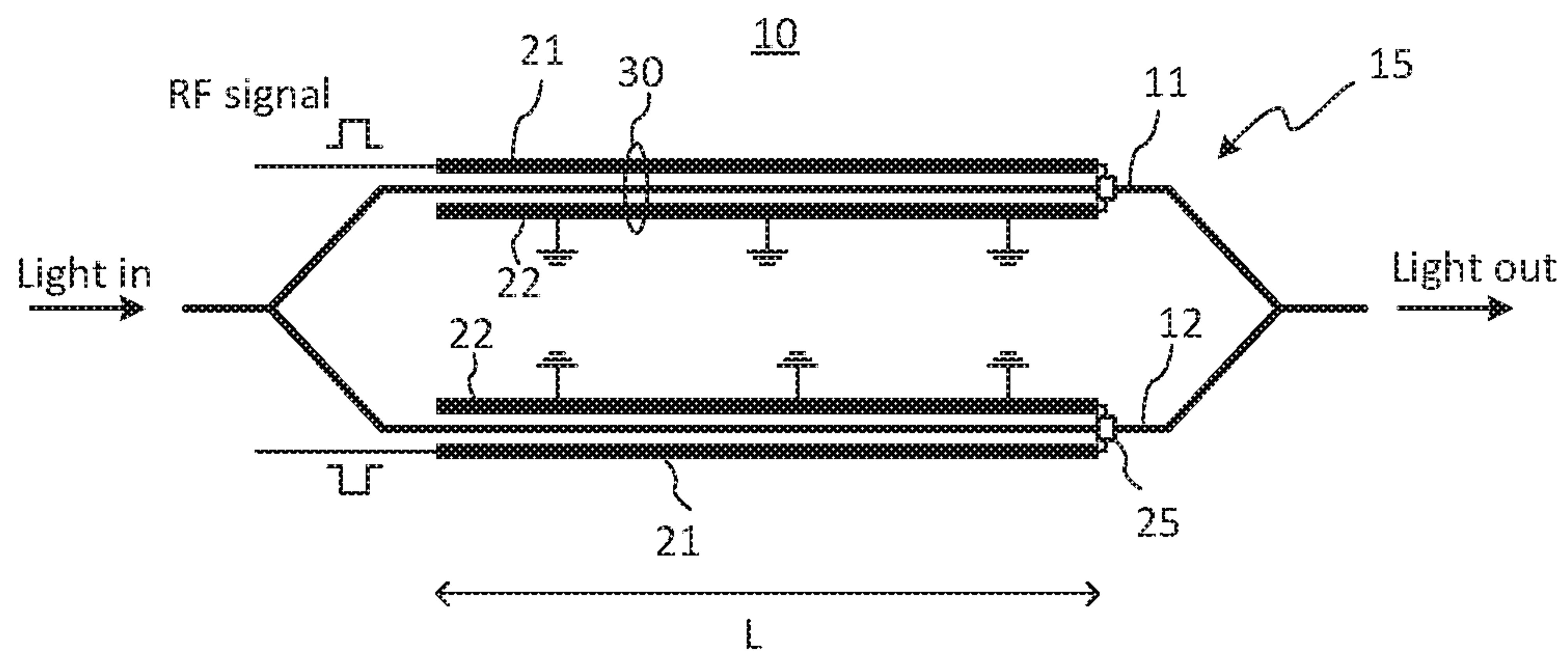

FIG. 1 (Prior Art)

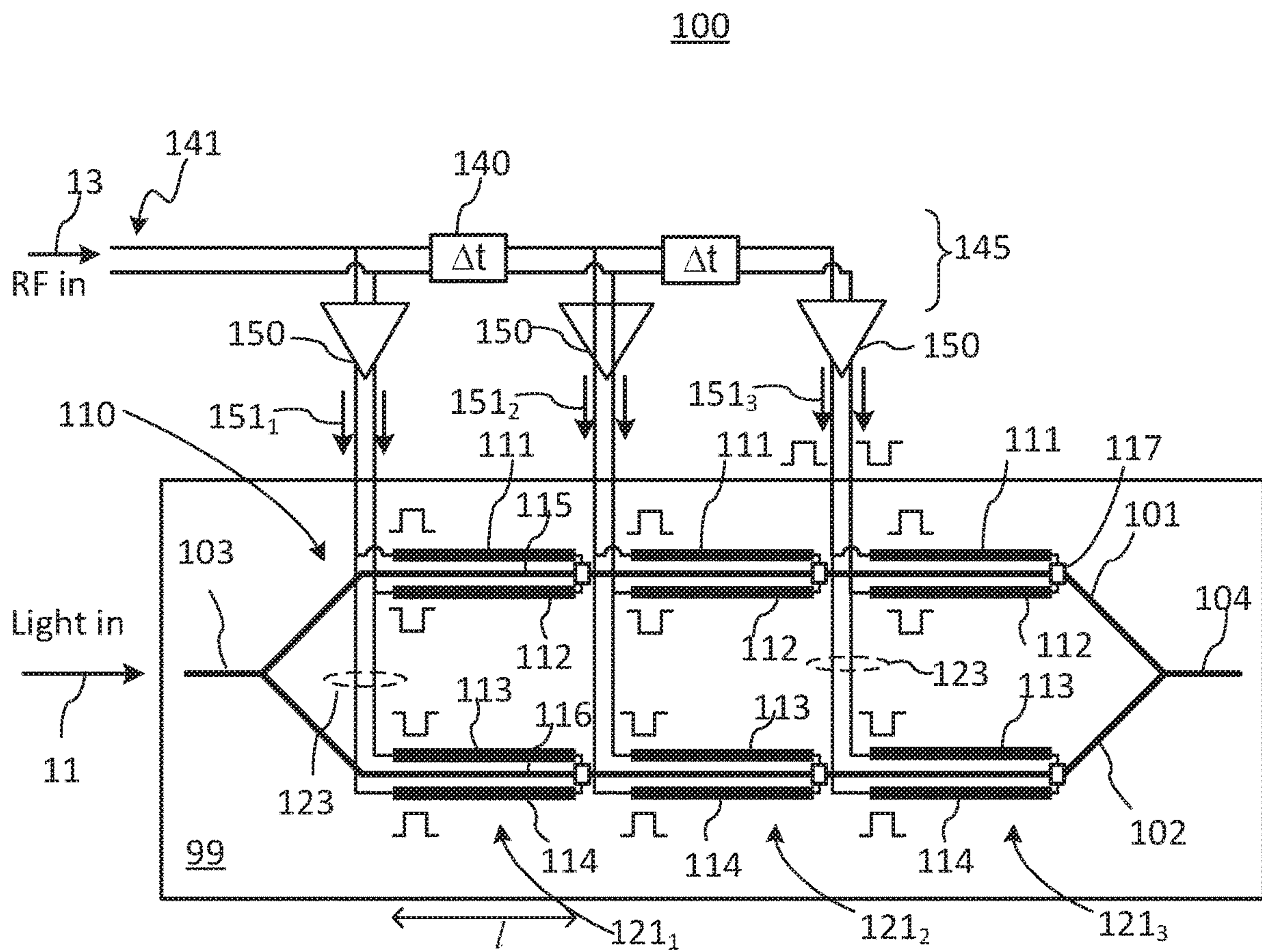

FIG. 2

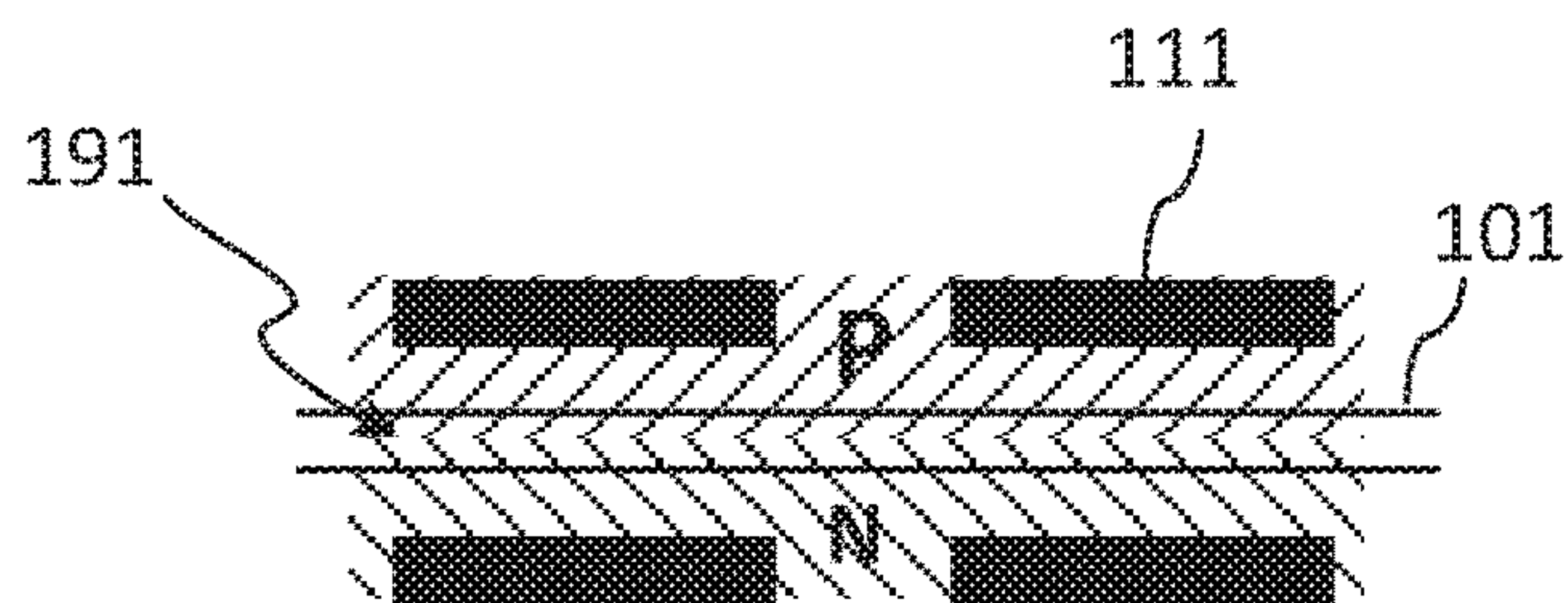

FIG. 3

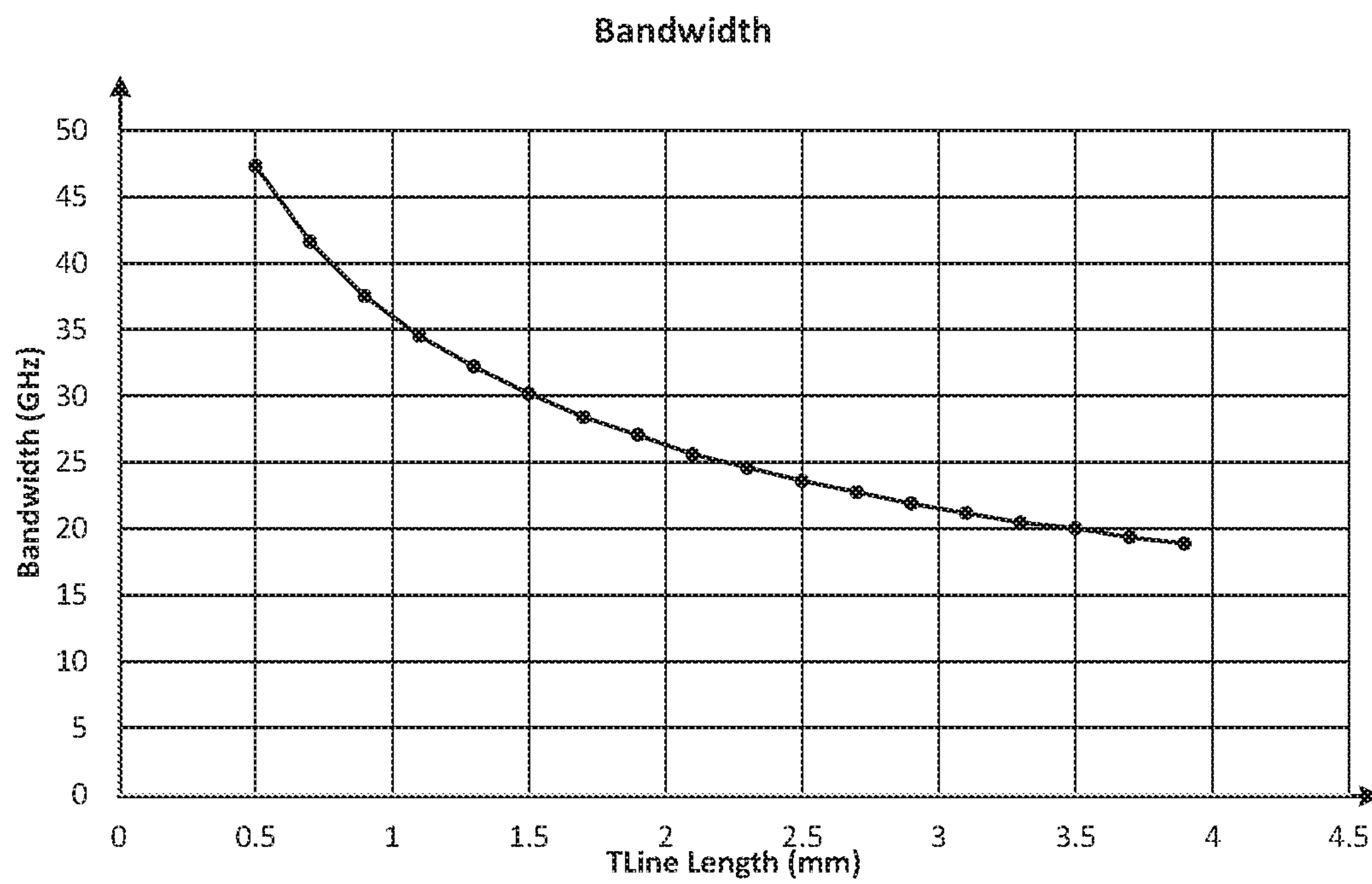

FIG. 4

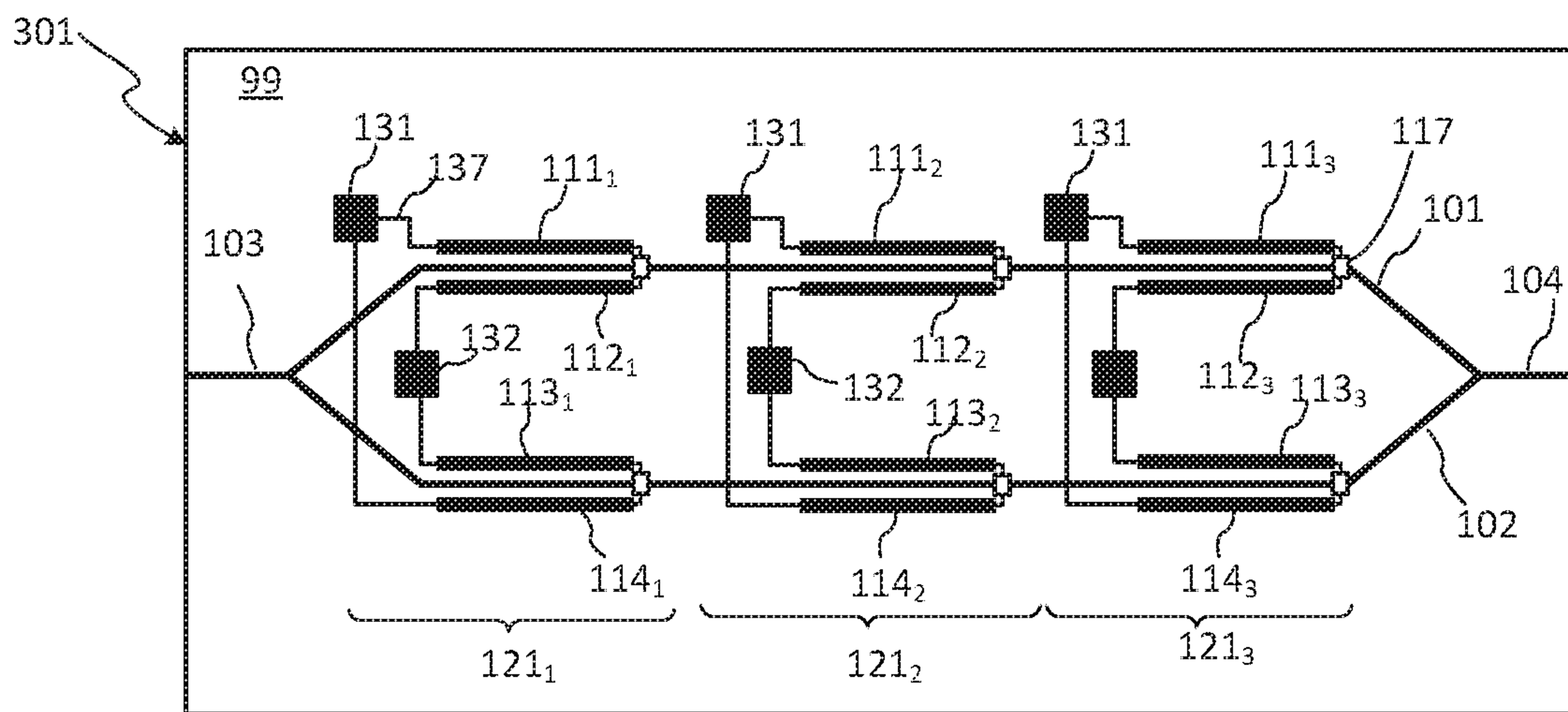

FIG. 5

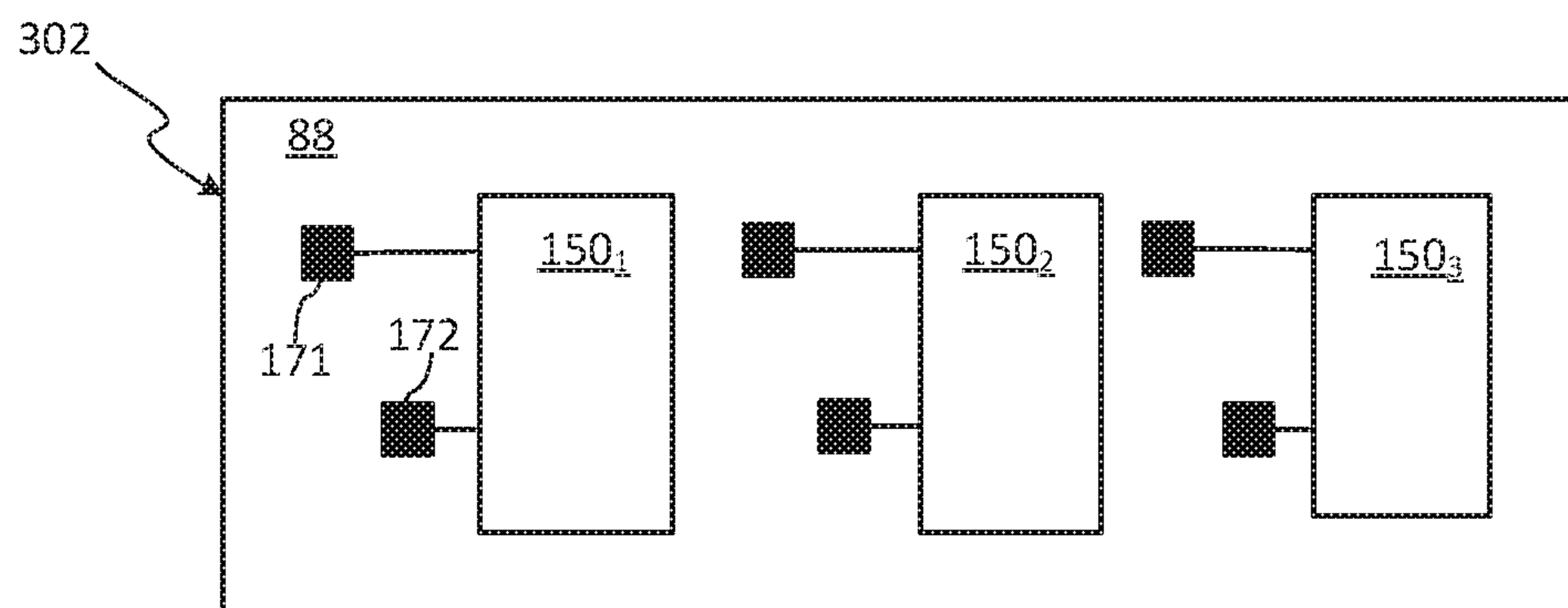

FIG. 6

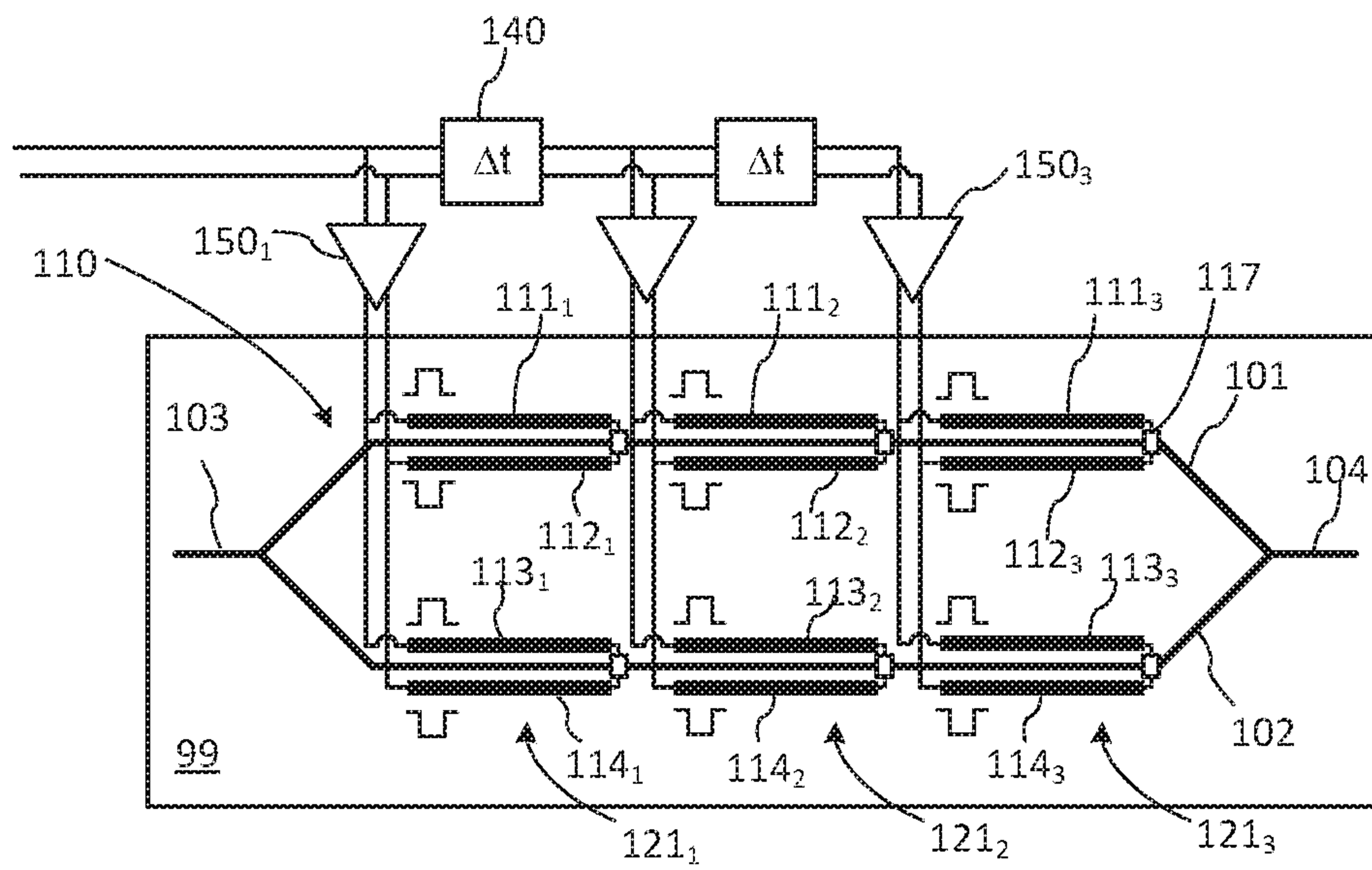

FIG. 7

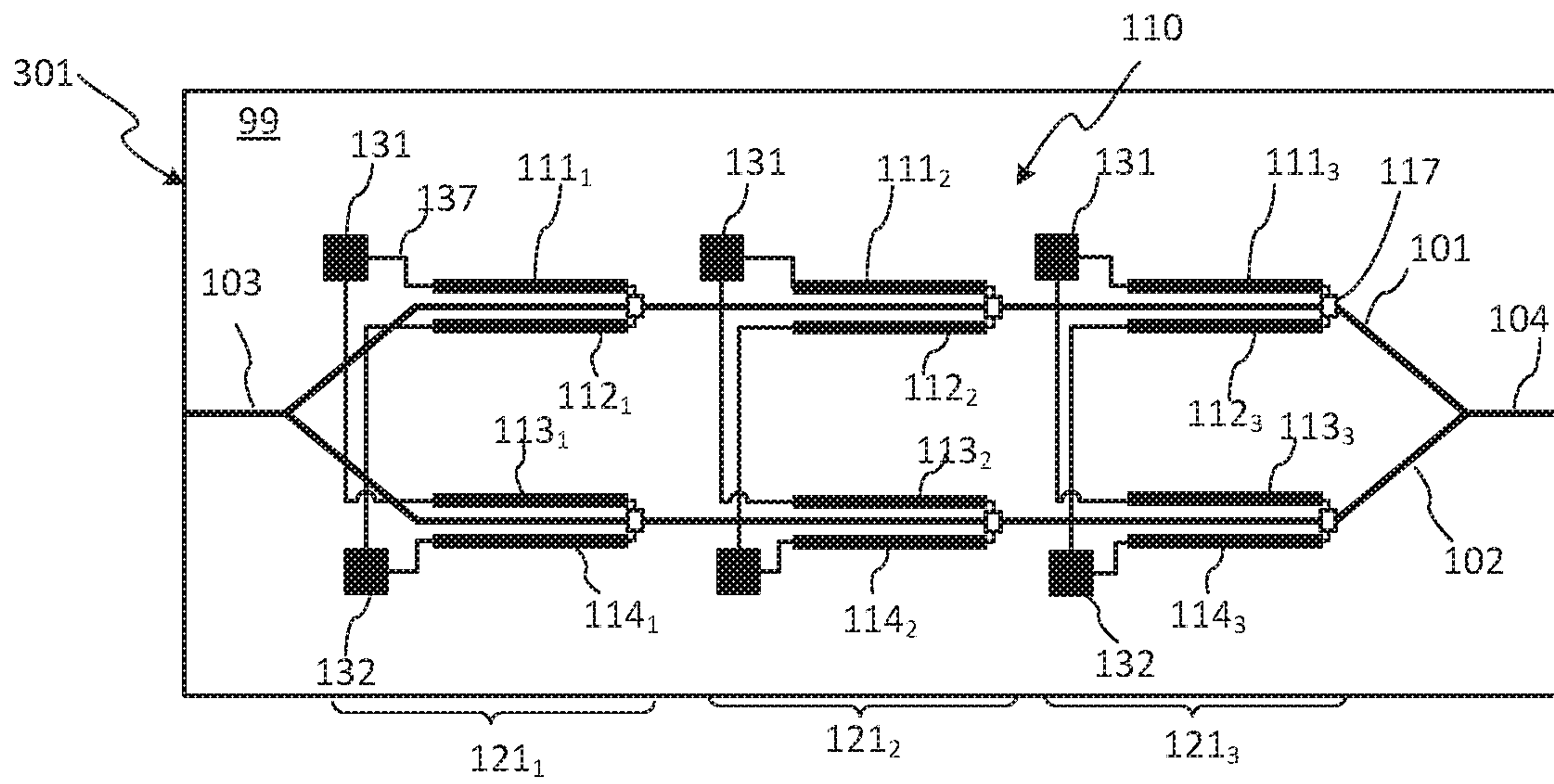

FIG. 8

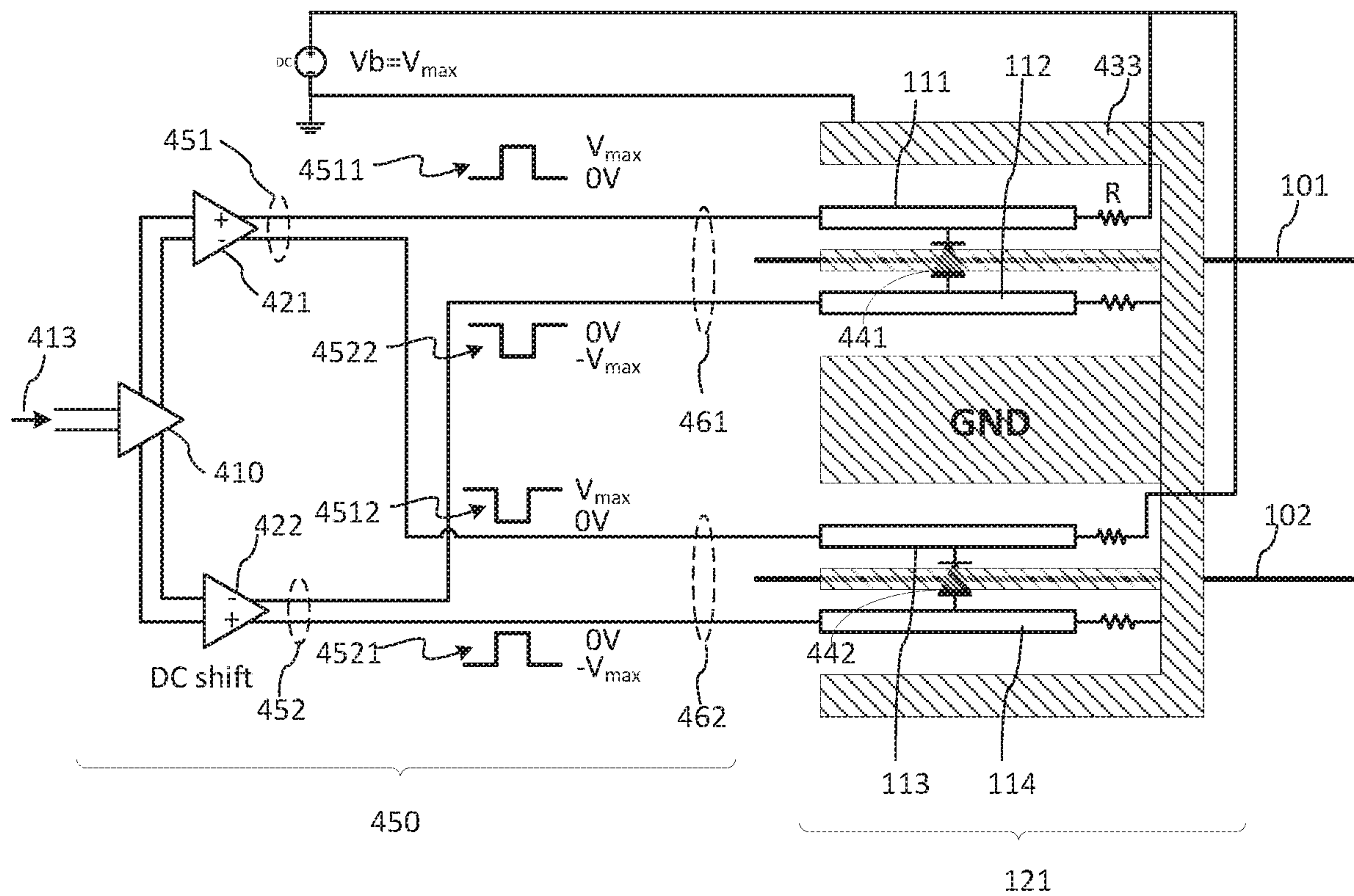

FIG. 9

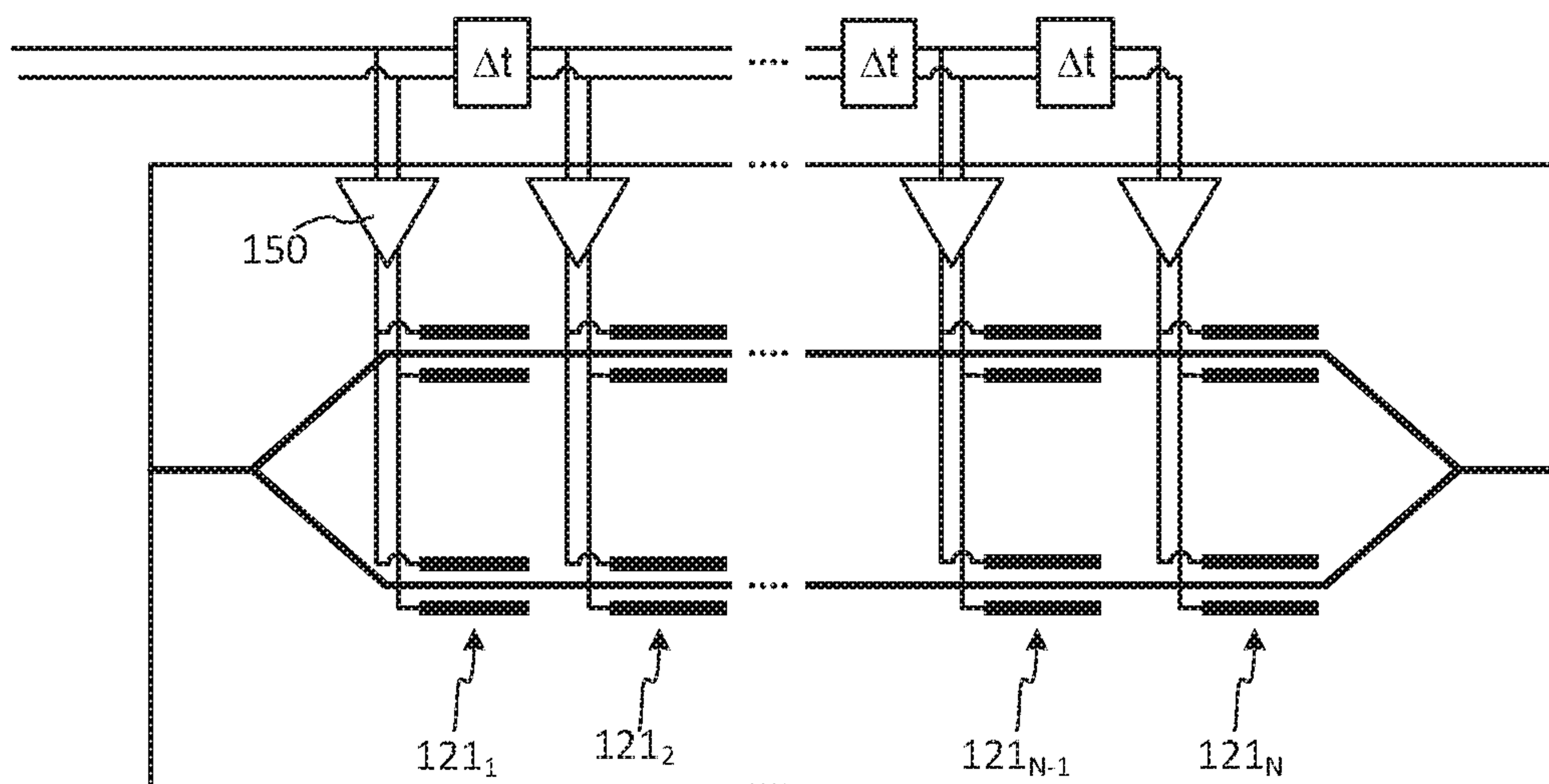

FIG. 10

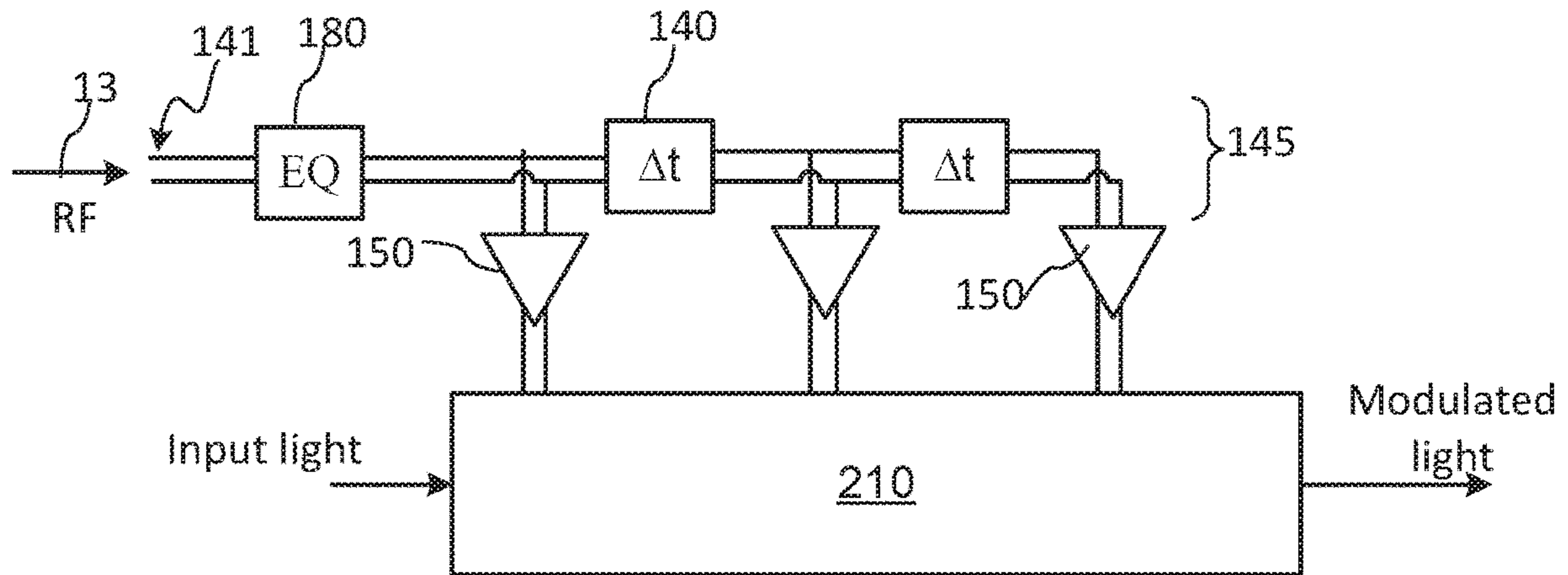

FIG. 11

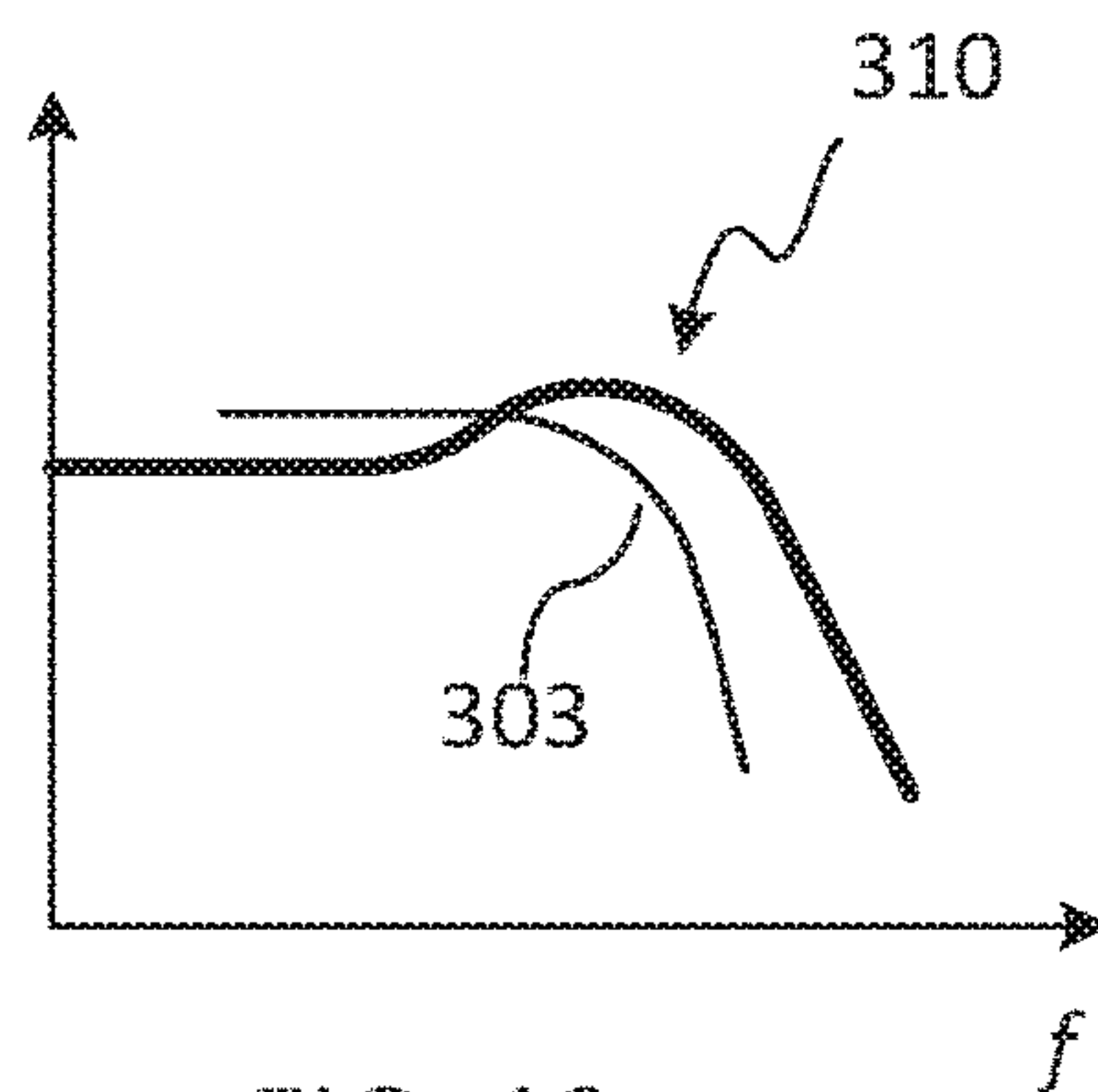

FIG. 12

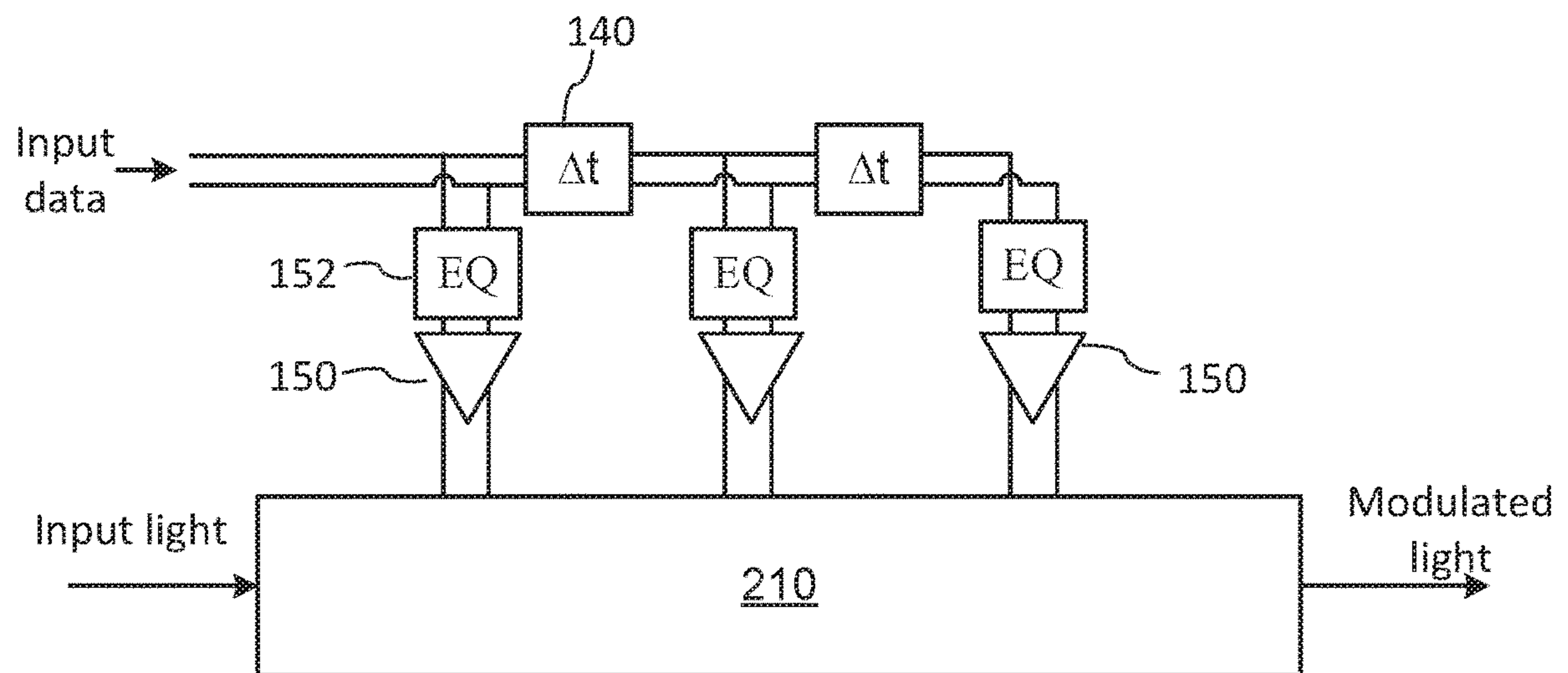

FIG. 13

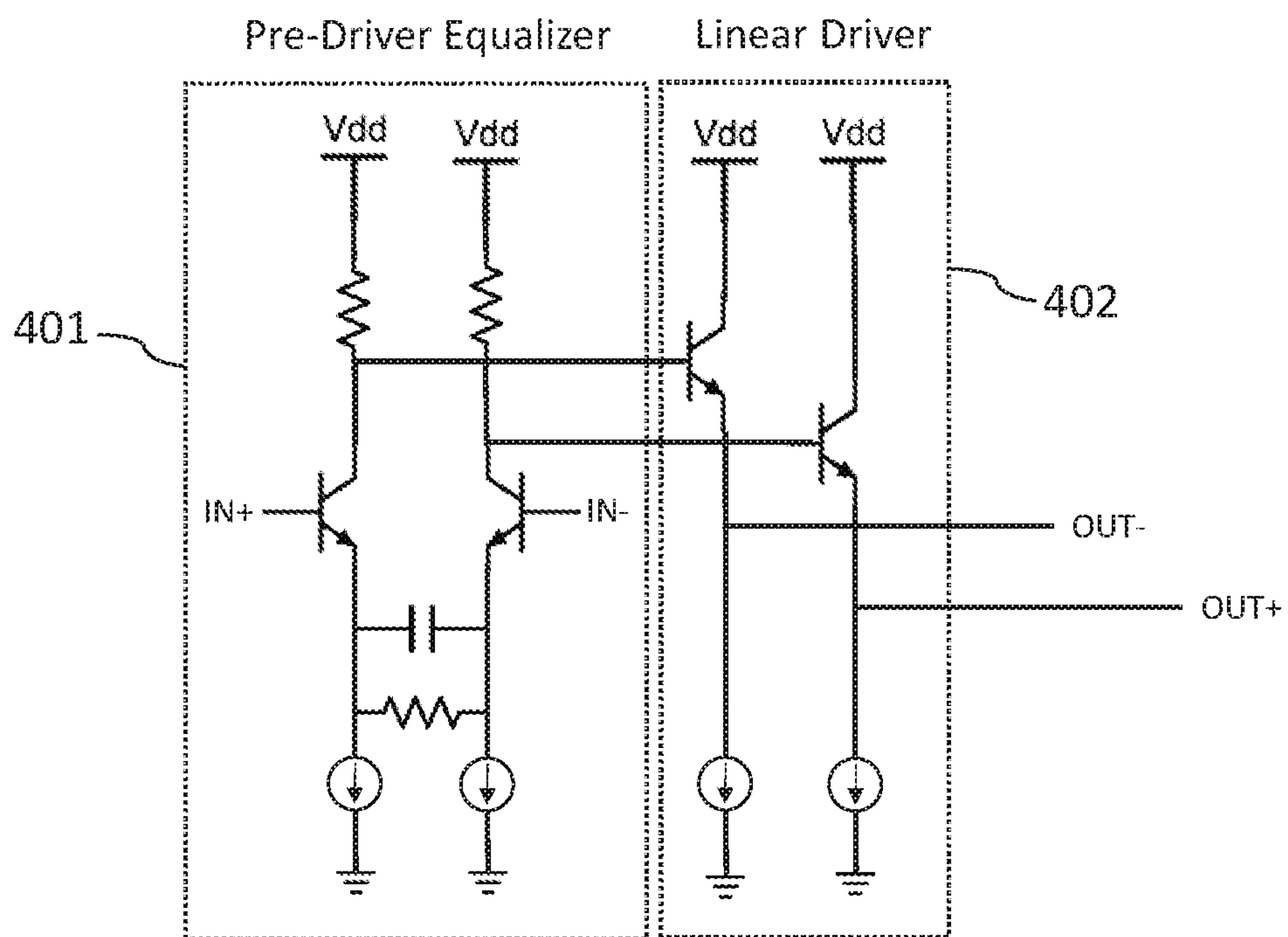

FIG. 14

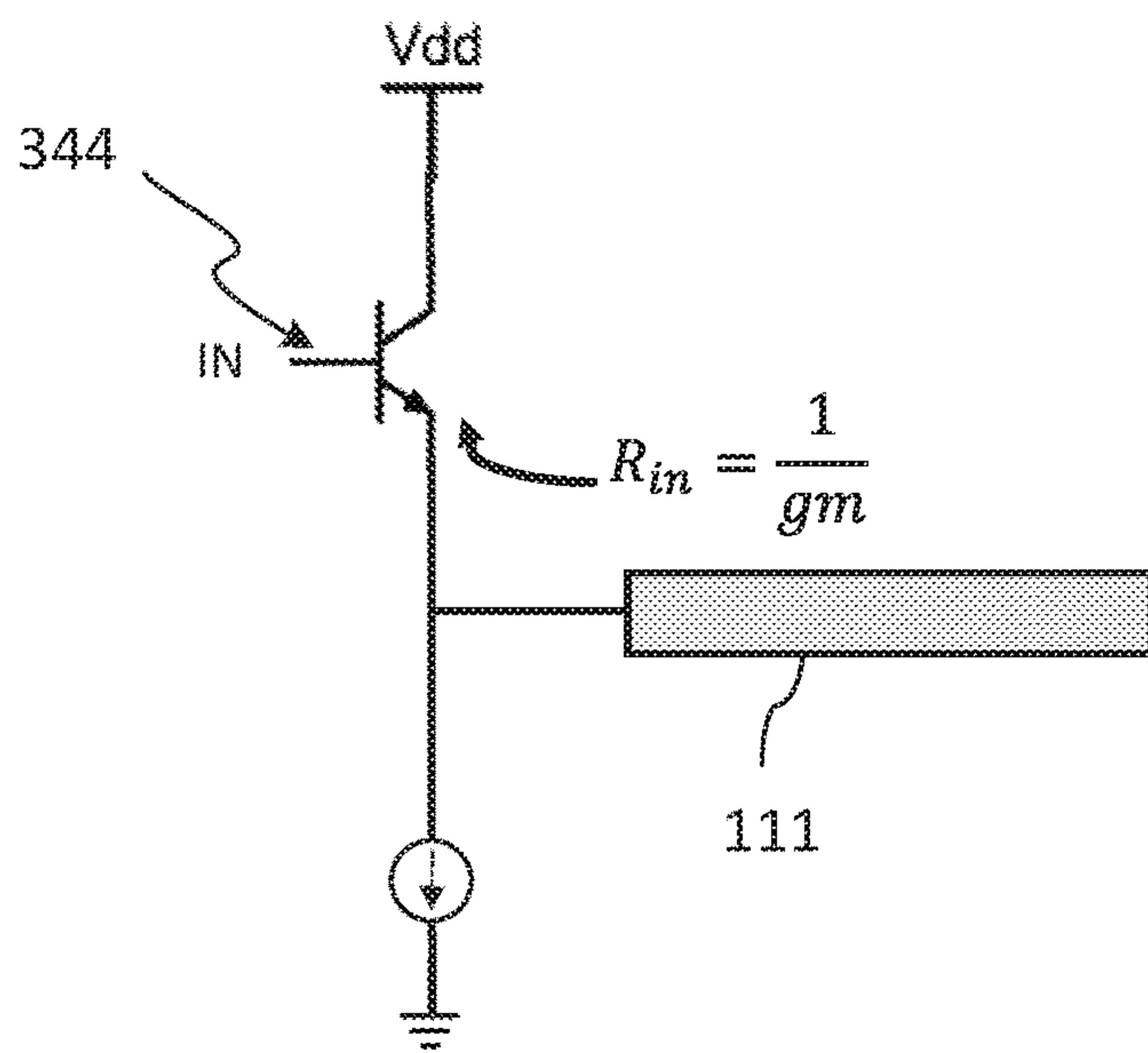

FIG. 15A

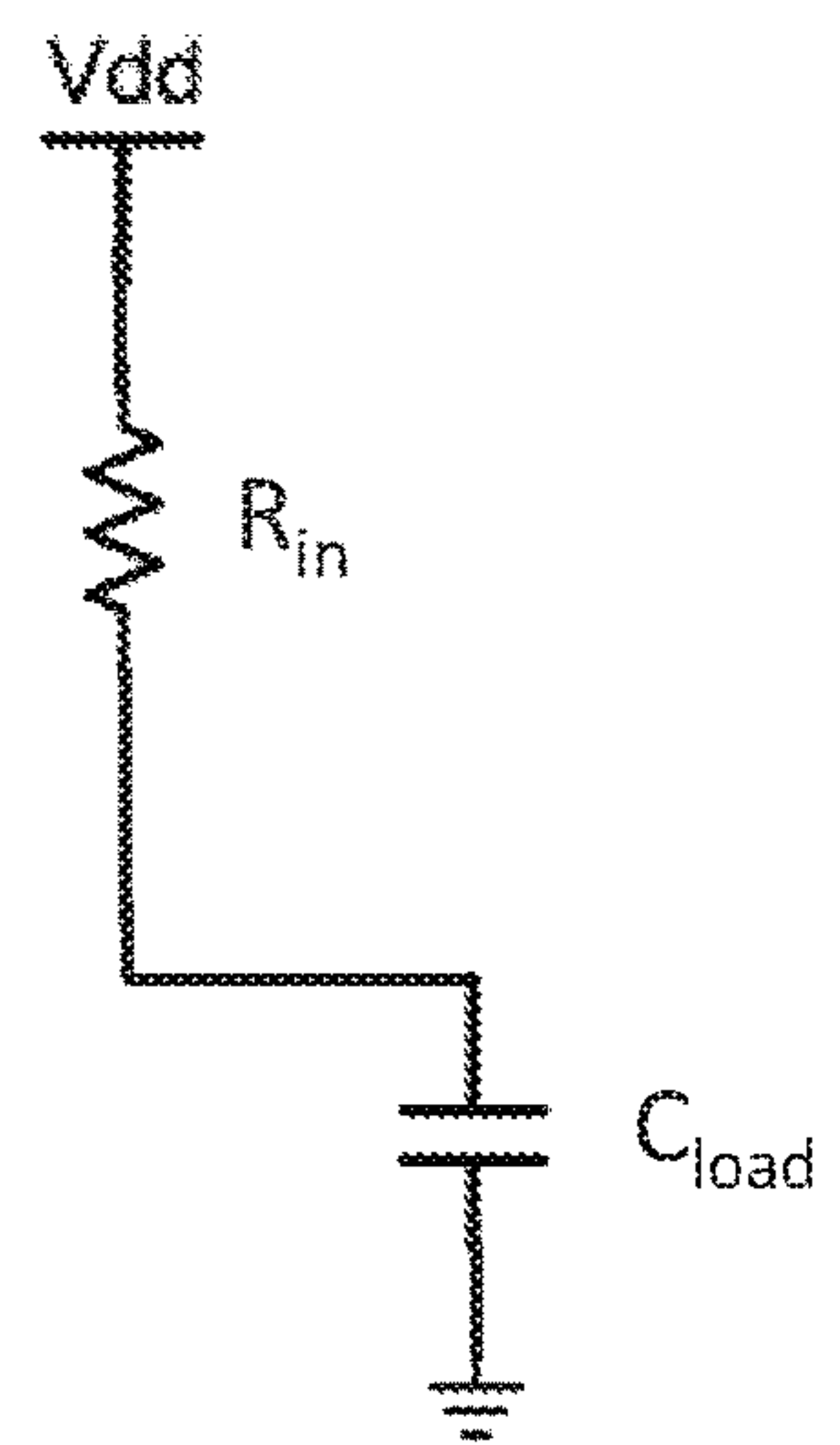

FIG. 15B

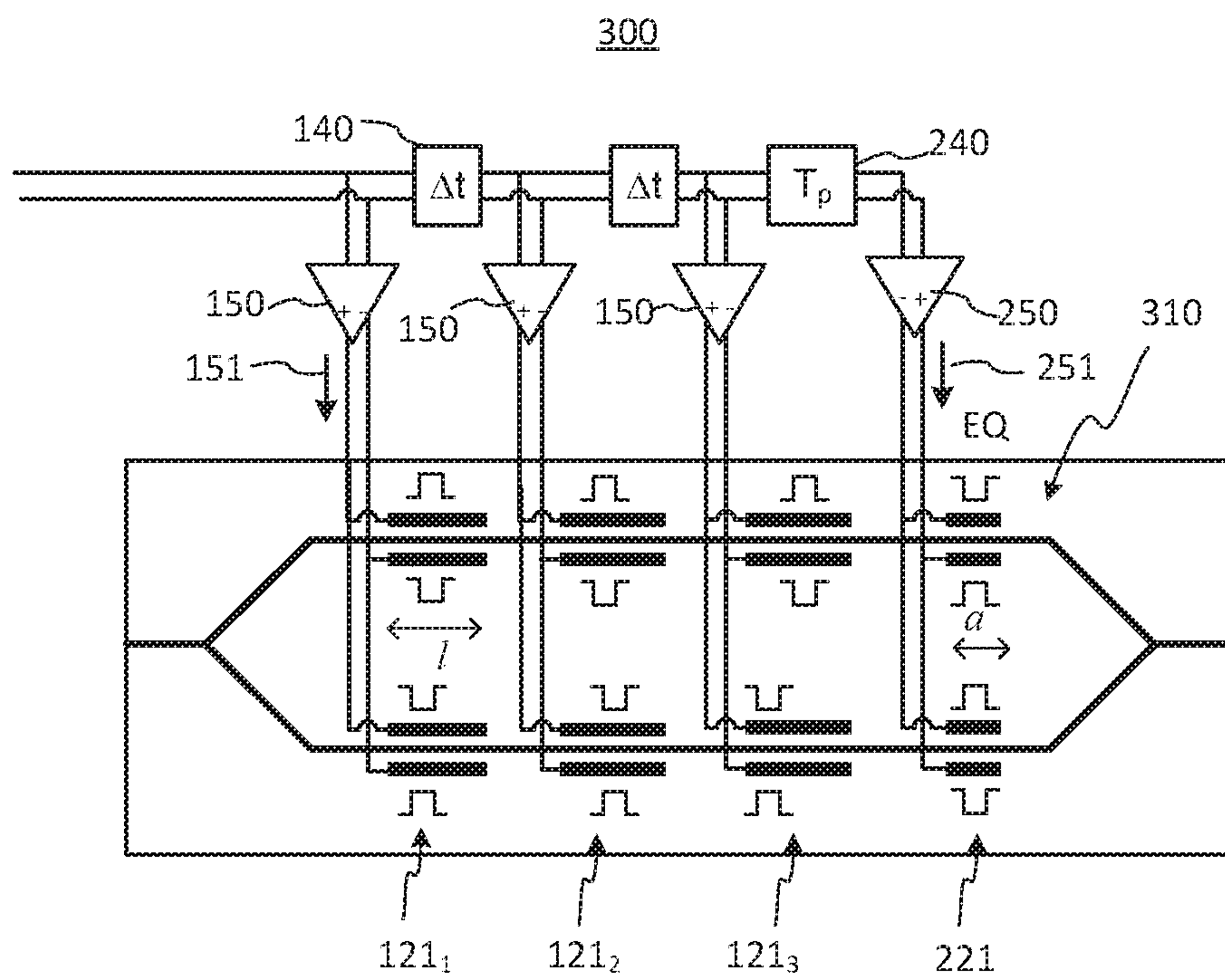

FIG. 16

Current steering logic stage

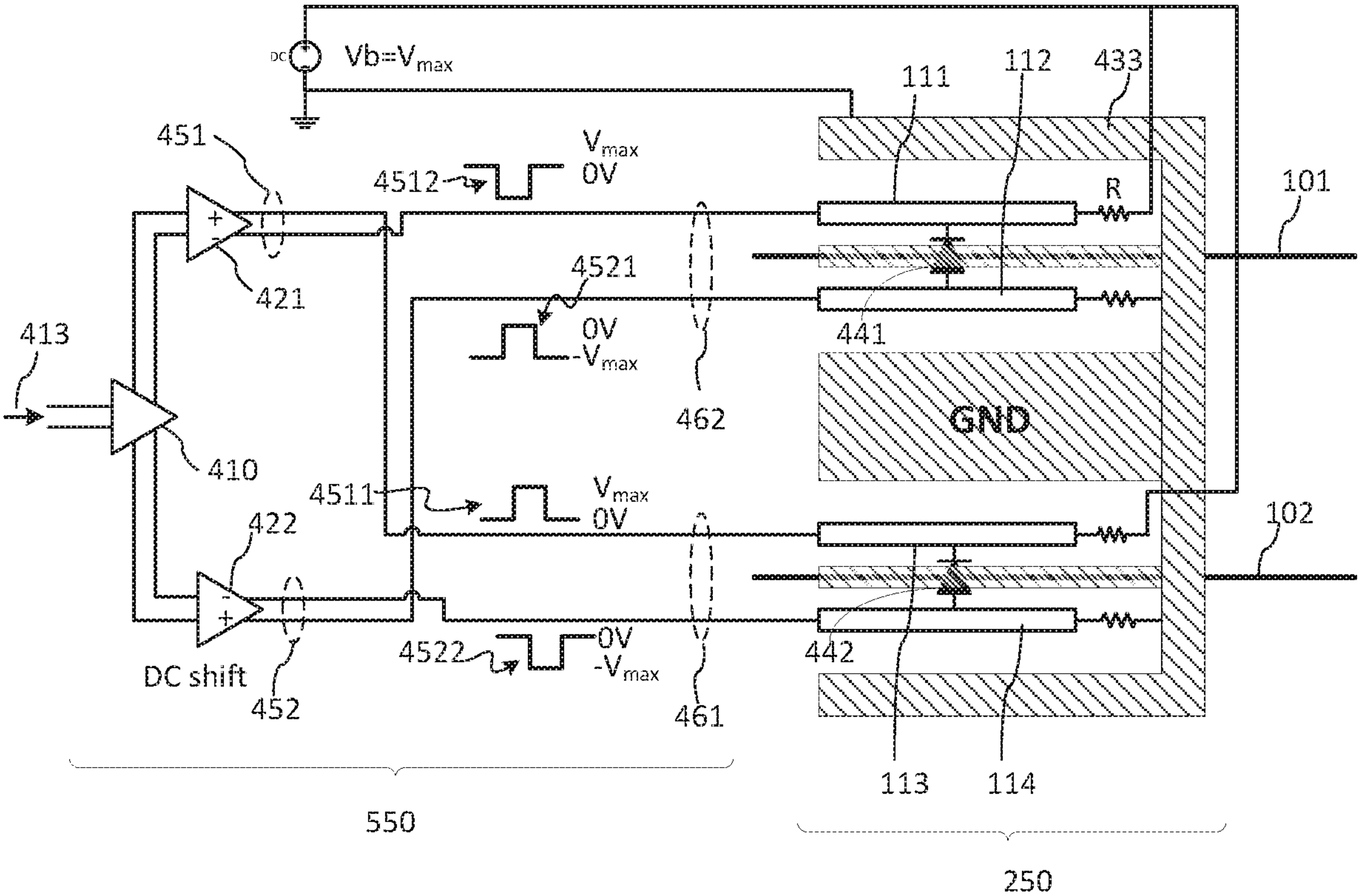

FIG. 17

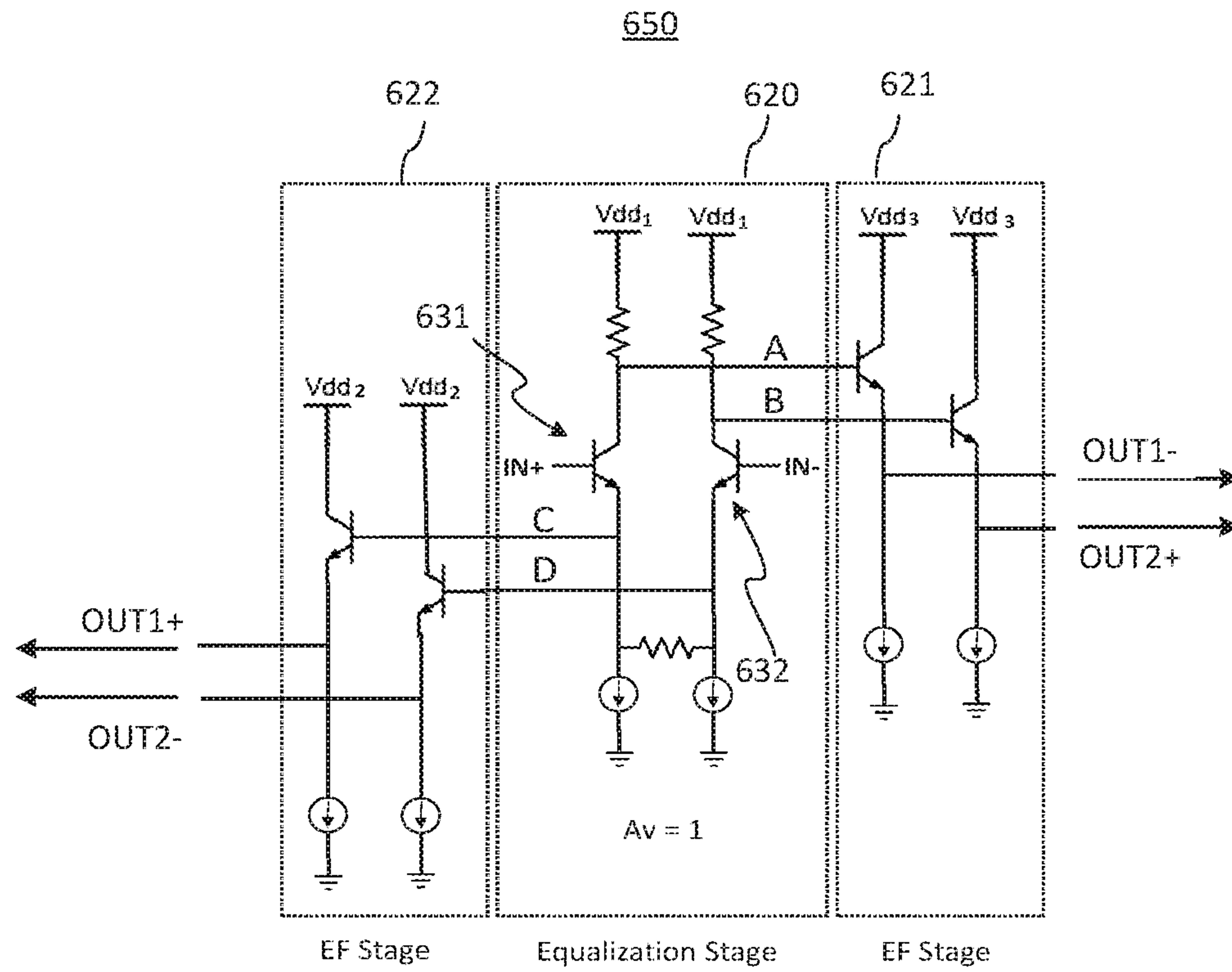

FIG. 18

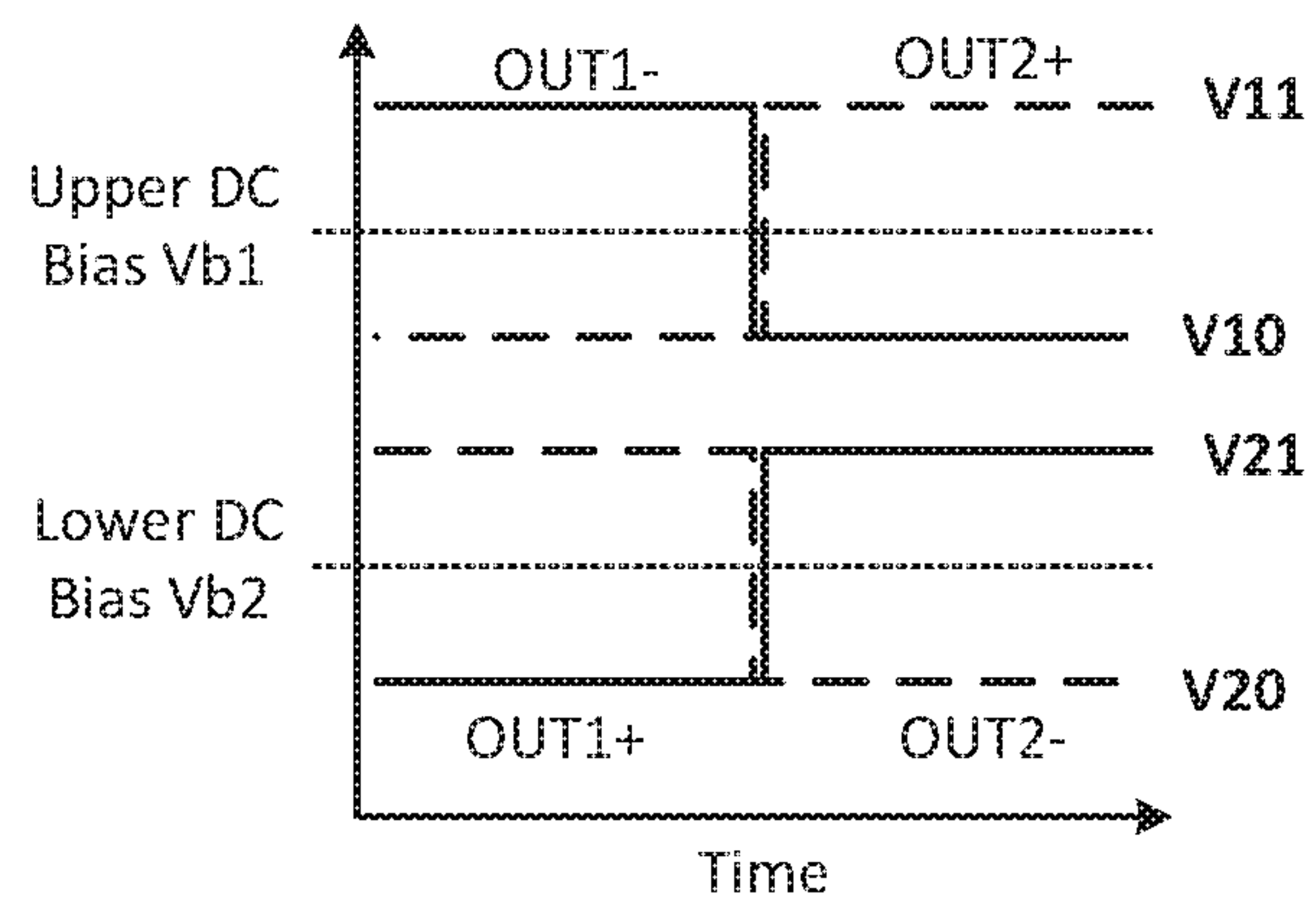

FIG. 19

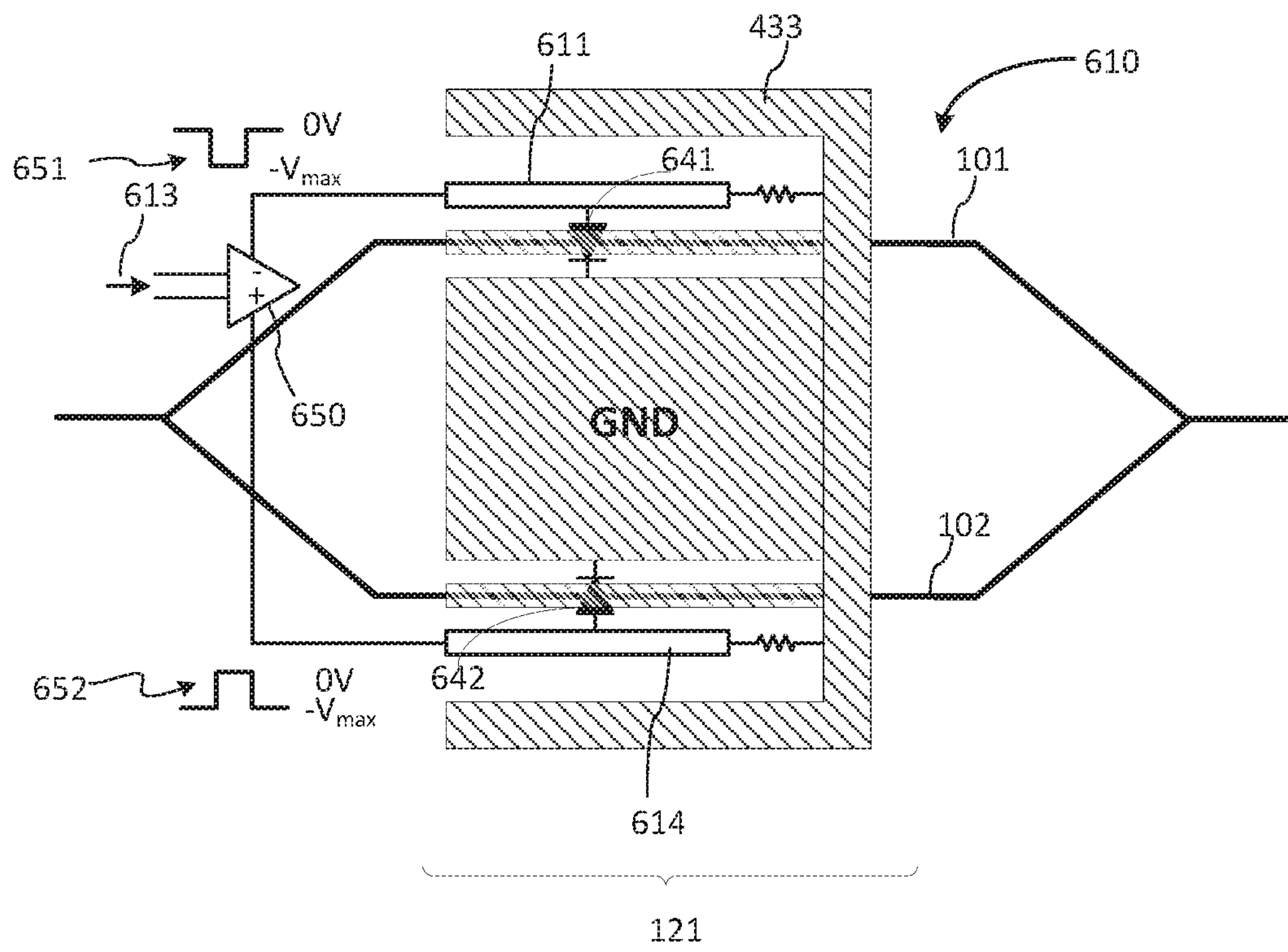

FIG. 20

1

OPTICAL WAVEGUIDE MODULATOR

CROSS-REFERENCE TO RELATED
APPLICATIONS

This application is a continuation of U.S. patent application Ser. No. 16,202,818, filed Nov. 28, 2018, now allowed, a continuation of U.S. patent application Ser. No. 15/602,657, filed May 23, 2017, now U.S. Pat. No. 10,168,596, which are hereby incorporated by reference in their entireties.

TECHNICAL FIELD

The present invention generally relates to optical modulators, and more particularly relates to a broad-band optical waveguide modulator with segmented electrodes configured for dual-differential driving.

BACKGROUND

Broad-band optical communications typically require high-speed electro-optical modulators (EOM) to modulate light at a desired data rate. One common type of a broad-band EOM is a Mach-Zehnder modulator (MZM) that uses a waveguide Mach-Zehnder (MZ) interferometric structure with RF-driven optical phase modulators in each arm. The waveguide arms of the MZM are typically formed in an electro-optic material, for example a suitable semiconductor or electro-optic material such as LiNbO_3 , where optical properties of the waveguide may be controlled by applying a voltage. Such a waveguide modulator may be implemented in an opto-electronic chip as a photonic integrated circuit (PIC). A silicon photonics (SiP) platform based on Silicon on Insulator (SOI) technology may be particularly attractive for implementing broad-band modulators as it enables a natural integration with CMOS-based high-speed electronic drivers.

One common technique to high-speed modulation of propagating light, in particular at modulation rates on the order of 10-20 Gigabit per second (Gb/s) and higher, is the travelling wave approach, when the modulating electrical RF signals are applied to properly terminated electrical transmission lines that are electro-optically coupled and velocity-matched to the optical waveguides of the EOM. FIG. 1 schematically illustrates an example broad-band EOM in the form of an MZM 10 with two waveguide arms 11, 12 coupled to two electrical transmission lines 30 of length L, each formed by an inner electrode 22 and an outer electrode 21 with a transmission line termination 25. In the SiP platform, the electrodes 21, 22 may be overlaying p/n junctions formed across the waveguide arms that may either inject carriers (forward bias) or deplete carriers (reverse bias) in the waveguide core to modulate the refractive index of the waveguide by means of the carrier plasma dispersion effect. A common approach is to have the inner electrodes 22 connected to the ground, and to use a differential RF signal to drive the outer electrodes 21, so as to effectively double the phase modulation amplitude at the output combiner for a given peak-to-peak (PP) drive voltage V_{pp} applied to each electrode. In one common implementation, the transmission lines 30 modulate reverse-biased PN junctions formed along the length of the line, which modulate the light that is travelling in the waveguide arms 11, 12 at the same velocity as the RF signals propagating in the transmission lines 30.

Such traveling-wave modulators however present a design trade-off: increasing the length of the transmission

2

lines in the EOMs improves the optical eye opening at the output of the modulator, but reduce the modulator bandwidth and increases the size of the modulator. The optical eye opening at the output of the modulator may be expressed in terms of the optical modulation amplitude (OMA), which may be defined as the difference in optical power between the "ON" and "OFF" levels for the On-Off-Keyed (OOK) modulation. Thus, designing EOMs having a sufficiently high OMA at a target bandwidth remains a challenge.

Accordingly, it may be understood that there may be significant problems and shortcomings associated with current solutions and technologies for providing high-bandwidth optical waveguide modulators with a suitably low OMA loss.

SUMMARY

Accordingly, the present disclosure relates to an optical waveguide modulator comprising: an input optical port for receiving input light, an output optical port for outputting modulated light; first and second waveguide arms extending optically in parallel between the input and output optical ports to guide the input light from the input port to the output port along two light paths, a plurality of N modulating subsystems sequentially disposed along the first and second waveguide arms, wherein $N \geq 2$, and a plurality of N electrical drive circuits for individually driving the N modulating subsystems, each of the N electric drive circuits configured to provide a differential drive signal to each of the first and second waveguide arms of one of the N modulating subsystems. Each modulating subsystem may comprise a first pair of electrodes disposed along a length portion of the first waveguide arm at opposite sides thereof so as to be electro-optically coupled thereto, and a second pair of electrodes disposed along a length portion of the second waveguide arm at opposite sides thereof so as to be electro-optically coupled thereto, with each of the N electric drive circuits electrically coupled to each electrode of the first and second pairs of electrodes of one of the N modulating subsystems for differentially driving both the first and second pairs of electrodes of said modulating subsystem separately from other modulating subsystems.

According to an aspect of the present disclosure, the modulator may comprising a substrate comprising semiconductor material wherein the first and second waveguide arms and the plurality of N modulating subsystems. Each of the N modulating subsystems may comprise a first p/n junction formed in the length portion of the first waveguide arm and electrically connected between the first pair of electrodes, and a second p/n junction formed in the length portion of the second waveguide arm and electrically connected between the second pair of electrodes. Each of the first and second p/n junctions may be configured to vary a refractive index in the respective length portion of the first or second waveguide arm in response to the differential drive signal provided to the corresponding first or second pair of electrodes. In one implementation each of the N electrical drive circuits may comprise two differential drivers that are DC-coupled to the first and second pairs of electrodes of one of the N modulating subsystems, the two differential drivers configured to convert an input data signal into two synchronous differential drive signals having a DC shift therebetween.

In accordance with an aspect of the present disclosure, the plurality of N electrical drive circuits may comprise an equalizing circuit configured to drive one of the N modulating subsystems, termed an equalizing subsystem, with a differential drive signal that is inverted relative to at least

one other differential drive signal that is provided to at least one other modulating subsystem from the plurality of N modulating subsystems, thereby affecting a modulation of the input light that subtracts from a modulation of the input light by the at least one other modulating subsystem with a relative time delay that is selected so as to at least partially compensate for a modulation signal dispersion associated with a high-frequency roll-off of a light modulation efficiency of the modulating subsystems.

Another aspect of the present disclosure relates to a method of modulating input light, the method comprising:

a) receiving the input light into an input optical port of an optical modulator comprising first and second waveguide arms extending optically in parallel between the input optical port and an output optical port, for transmitting the input light from the input port to the output port along two light paths traversing N successive modulating sections of the optical modulator, $N \geq 2$;

b) providing a differential drive signal separately to each of the plurality of N successive modulating sections of the optical modulator generally in synchronism with the transmission of the input light along the waveguide arms; and,

c) in each of the N modulating sections, applying the differential drive signal, or a signal related thereto, separately to each of the first and second waveguide arms.

The method may include converting an input data signal into N differential drive signals that vary with time in a substantially same manner defined by the input data signal. Step (c) may comprise: in at least one of the N modulating sections, applying one of the N differential drive signals to a first pair of electrodes disposed within a respective modulating section so as to be electro-optically coupled to the first waveguide arm along a length portion thereof located within said modulating section, and applying an inverted version of the one of the N differential drive signals to a second pair of electrodes disposed within said modulating section so as to be electro-optically coupled to the second waveguide arm along a length portion thereof located within said modulating section, so as to affect a dual-differential push-pull modulation of the input light in each of the N successive modulating sections of the optical modulator.

An aspect of the present disclosure relates to a method of modulating input light wherein the plurality of N modulating sections comprises a modulating section and an equalizing section, the method further comprising converting an input data signal into first and second differential drive signals that vary with time in a substantially same manner defined by the input data signal. The method may further comprise applying, in the modulating section, the first differential drive signal to a first pair of electrodes electro-optically coupled to the first waveguide arm within the first modulating section, and applying an inverted version of the first differential drive signal to a second pair of electrodes electro-optically coupled to the second waveguide arm within the first modulating section, so as to affect a first dual-differential push-pull modulation of the input light propagating through the first modulating section of the optical modulator. The method may further include applying, in the equalizing section, an inverted version of the second differential drive signal from the plurality of N differential drive signals to a first pair of electrodes electro-optically coupled to the first waveguide arm within the equalizing section, and applying the second differential drive signal to a second pair of electrodes electro-optically coupled to the second waveguide arm within the equalizing section, so as to affect a second dual-differential push-pull modulation of the input light propagating through the equalizing section of the

optical modulator. The second dual-differential push-pull modulation substantially subtracts from the first dual-differential push-pull modulation with a relative delay therebetween that is selected so as to at least partially compensate for a modulation dispersion associated with a high-frequency roll-off of a light modulation efficiency of the modulating subsystems.

An aspect of the present disclosure relates to an optical waveguide modulator comprising an input optical port for receiving input light, an output optical port for outputting modulated light, first and second waveguide arms extending optically in parallel between the input and output optical ports to guide the input light from the input port to the output port along two light paths, and first and second p/n junction formed in the first and second waveguide arm, respectively. Each of the first and second p/n junctions is provided with a cathode electrode electrically connected to the n-side of said p/n junction and an anode electrode electrically connected to the p-side of said p/n junction. An electrical drive circuit is further provided that is configured for dual-differential driving the first and second p/n junctions; the electrical drive circuit comprises two differential drivers that are configured to convert an input data signal, or a signal obtained therefrom, into two synchronous differential signals having a DC shift therebetween, wherein each of which is DC-coupled to the cathode electrode of one of the p/n junctions and the anode electrode of the other one of the p/n junctions.

An aspect of the present disclosure relates to an optical waveguide modulator comprising an input optical port for receiving input light, an output optical port for outputting modulated light, first and second waveguide arms extending optically in parallel between the input and output optical ports to guide the input light from the input port to the output port along two light paths, and first and second p/n junction formed in the first and second waveguide arm, respectively. Each of the first and second p/n junctions is provided with an anode electrode electrically connected to the p-side of said p/n junction, with the n-side of said p/n junction connected to a ground plane. Each of the anode electrodes may form an electrical transmission line with the ground plane. The optical waveguide modulator may further comprise a differential driver that is configured to be fed with a negative supply voltage is DC-coupled to the anode electrodes of each of the first and second p/n junctions to apply complementary single-ended signals thereto for affecting a push-pull modulation of the input light. Each of the anode electrodes may be terminated with a resistor connection to the ground plane.

BRIEF DESCRIPTION OF THE DRAWINGS

Embodiments disclosed herein will be described in greater detail with reference to the accompanying drawings which represent preferred embodiments thereof, in which like elements are indicated with like reference numerals, and wherein:

FIG. 1 is a schematic block diagram of a travelling-wave waveguide Mach-Zehnder modulator;

FIG. 2 is a schematic diagram of an optical modulator with segmented electrode system and a dual-differential drive circuit for each electrode subsystem, with outer electrodes connected to receive a same single-ended signal complimentary to that received by the inner electrodes;

FIG. 3 is a schematic expanded view of a portion of a waveguide arm of one embodiment of the modulator of FIG. 2 with a modulating p/n junction;

5

FIG. 4 is a graph illustrating the modulation bandwidth as a function of electrode length for a Silicon-based modulator;

FIG. 5 is a schematic diagram of a photonics chip of an embodiment of the optical modulator of FIG. 2 showing electrical contacts and differential signal paths for driving each modulating section, with interconnected outer electrodes and interconnected inner electrodes in each section driven by complimentary single-ended signals;

FIG. 6 is a schematic diagram of a driver chip for operating with the photonics chip of FIG. 5;

FIG. 7 is a schematic diagram of another embodiment of an optical modulator with segmented electrode system and a dual-differential drive circuit for each electrode subsystem, in which outer electrodes are connected to receive complimentary single-ended signals;

FIG. 8 is a schematic diagram of a photonics chip of an embodiment of the optical modulator of FIG. 7 showing electrical contacts and differential signal paths for driving each modulating section, with each inner electrode electrically coupled to a different outer electrode of the modulating section;

FIG. 9 is a diagram showing a schematic plan view of an example modulating section of an EOM and a block diagram of a dual-differential driving circuit with differential drivers according to one embodiment;

FIG. 10 is a schematic diagram of an optical modulator with segmented electrode system formed of four or more short electrode segments without termination;

FIG. 11 is a schematic diagram of electrical driving circuitry of the modulator of FIG. 1 with a common pre-equalizer;

FIG. 12 is a graph schematically illustrating a high-frequency pre-emphasis provided by the pre-equalization circuit;

FIG. 13 is a schematic diagram of electrical driving circuitry of the modulator of FIG. 1 with a pre-equalizer in the driving circuit of each electrode subsystem;

FIG. 14 is a simplified circuit diagram of a linear differential driver with a pre-equalization stage;

FIG. 15A is a simplified diagram of an electrical drive circuit of one electrode segment;

FIG. 15B is a diagram of a simplified equivalent electrical circuit of the driver circuit of FIG. 15A;

FIG. 16 is a schematic diagram of a sectionalized optical modulator with an equalization section;

FIG. 17 is a schematic diagram illustrating a plan view of an equalizing section EQ of the EOM of FIG. 16 and a block diagram of its driving circuitry according to an embodiment wherein the modulating sections are driven as illustrated in FIG. 9; the outputs of each of the differential drivers in the EQ driving circuit are inverted as compared to their outputs in the driving circuit of a modulating sections of the same EOM illustrated in FIG. 9;

FIG. 18 is a schematic diagram of an example electrical circuit that may be used to implement a dual differential driver with DC shifted differential outputs;

FIG. 19 is a graph illustrating the DC-shifted dual-differential outputs produced by the dual differential drivers of FIGS. 9, 17, and 18;

FIG. 20 is a schematic diagram illustrating an EOM with ground-terminated anode electrodes DC coupled to a negative-voltage differential driver and ground-referenced cathode electrodes of the p/n junctions.

DETAILED DESCRIPTION

In the following description, for purposes of explanation and not limitation, specific details are set forth, such as

6

particular circuits, circuit components, techniques, etc. in order to provide a thorough understanding of the present invention. However, it will be apparent to one skilled in the art that the present invention may be practiced in other embodiments that depart from these specific details. In other instances, detailed descriptions of well-known methods, devices, and circuits are omitted so as not to obscure the description of the present invention. All statements herein reciting principles, aspects, and embodiments of the invention, as well as specific examples thereof, are intended to encompass both structural and functional equivalents thereof. Additionally, it is intended that such equivalents include both currently known equivalents as well as equivalents developed in the future, i.e., any elements developed that perform the same function, regardless of structure.

Furthermore, the following abbreviations and acronyms may be used in the present document:

CMOS Complementary Metal-Oxide-Semiconductor

BiCMOS Bipolar CMOS

GaAs Gallium Arsenide

InP Indium Phosphide

LiNbO₃ Lithium Niobate

PIC Photonic Integrated Circuits

SOI Silicon on Insulator

SiP Silicon Photonics

PSK Phase Shift Keying

BPSK Binary Phase Shift Keying

QAM Quadrature Amplitude Modulation

QPSK Quaternary Phase Shift Keying

RF Radio Frequency

DC Direct Current

AC Alternate Current

OSNR Optical Signal to Noise Ratio

Note that as used herein, the terms “first”, “second” and so forth are not intended to imply sequential ordering, but rather are intended to distinguish one element from another, unless explicitly stated. Similarly, sequential ordering of method steps does not imply a sequential order of their execution, unless explicitly stated. The word ‘using’, when used in a description of a method or process performed by an optical device such as a polarizer or a waveguide, is to be understood as referring to an action performed by the optical device itself or by a component thereof rather than by an external agent. Notation $V\pi$ refers to a bias voltage of a Mach-Zehnder modulator (MZM) that corresponds to a change in a relative phase delay between arms of the MZM by π radian (rad), or 180 degrees, which corresponds to a change from a minimum to a next maximum in the MZM transmission versus voltage. Radio frequency (RF) may refer to any frequency in the range from kilohertz (kHz) to hundreds of gigahertz (GHz). The term p/n junction encompasses p/i/n junctions having a region of substantially intrinsic conductivity located between the p-doped and n-doped regions. The term “differential signal” refers to a signal that is transmitted using two single-ended signals having complementary AC components. The term “inverted differential signal” refers to a differential signal having AC components of its constituent single-ended signals inverted relative to those of a reference differential signal, or a differential signal having high-low and low-high transitions switched.

The present disclosure relates to an electro-optic modulator (EOM) and a related method in which two or more optical waveguides, also referred to herein as the waveguide arms, are used to guide input light from an input optical port to an output optical port along two or more optical paths; such EOMs may also be referred to herein as an optical

waveguide modulator or as an optical modulator. One aspect of the present disclosure relates to a multi-section EOM wherein the optical paths traverse N successive modulating sections of the optical modulator, $N \geq 2$, or preferably $N \geq 3$ in at least some embodiments. An electrical drive circuit is used to provide a differential drive signal separately to each of the N successive modulating sections of the EOM generally in synchronism with the transmission of the input light along the waveguide arms, and to apply the differential drive signal, or a signal related thereto, separately to each of the waveguide arms. In some embodiments, one or more of the modulating sections may be driven by inverted differential signals so as to operate as an equalizing section or sections. The EOM may include multiple electrodes that are disposed to modulate the light propagating in the waveguide arms in response to an applied electrical drive signal. The electrodes are arranged in a plurality of N electrode subsystems that are sequentially disposed along the direction of light propagation, so that each of the electrode subsystems defines one of the N consecutive modulating sections of the EOM. In example embodiments described hereinbelow the EOM is in the form of, or includes, an MZM, and each of the modulating sections includes two electrode pairs, each electrode pair sandwiching a length portion of one of the waveguide arms so as to be electro-optically coupled thereto. The EOM thus may include $4N$ separate electrodes, which may be dual-differentially driven using N electric drive circuits, each configured to provide a differential drive signal to each of the two electrode pairs of one of the N modulating sections. The N electric drive circuits may be configured to convert an input data signal into N differential drive signals that vary with time in a substantially same manner defined by the input data signal. By suitably selecting the electrode length of each of the modulating sections and the number of the modulating sections, a target modulation bandwidth may be achieved simultaneously with a target OSNR, or a target OMA for OOK modulation, or a target output power for a BPSK modulation.

In accordance with an aspect of the present disclosure, example embodiments of the EOM described hereinbelow may implement dual-differential driving of each of the modulating sections of the EOM, which may include, for at least one of the modulating sections, applying one of the N differential drive signals to a pair of electrodes sandwiching a length portion of the first waveguide arm within the modulating section, and applying an inverted version of the one of the N differential drive signals to a second pair of electrodes sandwiching a corresponding length portion of the second waveguide arm located within the modulating section, so as to affect a dual-differential push-pull modulation of the input light in each of the N successive modulating sections of the EOM.

With reference to FIG. 2, there is illustrated an embodiment of a multi-section EOM 100 which includes $N=3$ modulating subsystems by way of example; it will be appreciated that other embodiments may include a different number of sections, so that N can vary from two to ten and more. The multi-section EOM 100, and modifications thereof illustrated in FIGS. 7, 10, 11, 13, 16 may also be referred to as an optical waveguide modulator, or simply as the modulator device. The EOM 100 includes an MZM 110 having an input optical port 103, an output optical port 104, first and second waveguide arms 101 and 102, and $4N=12$ separate electrodes arranged to form three modulating subsystems 121₁, 121₂, and 121₃, which may be generally referred to as the modulating sections 121 of the EOM 100. The modulating sections 121 are sequentially disposed one

after another in the direction of light propagation from the input optical port 103 of the MZM 110 to its output optical port 104. The waveguide arms 101, 102 traverse the modulating sections 121₁, 121₂, and 121₃ in sequence. Each of the modulating sections 121 includes a first pair of electrodes 111, 112 disposed along a length portion 115 of the first waveguide arm 101 at opposite sides thereof, i.e. sandwiching a length portion 115 of the first waveguide arm 101 so as to be electro-optically coupled thereto. Each of the modulating sections 121 further includes a second pair of electrodes 113, 114 disposed along a length portion 116 of the second waveguide arm 102 at opposite sides thereof sandwiching a corresponding length portion of the second waveguide arm 102 and being electro-optically coupled thereto. The four electrodes 111-114 within each of the modulating section 121 may be referred to as the electrode subsystem 121. The term “electro-optically coupled” in the context of this disclosure means that a suitable voltage applied across the electrode pair changes the refractive index or any other optical property in the length portion of the waveguide arm between the two electrodes of the pair, for example by means of inducing an electrical field or an electrical current flow across the waveguide, or by changing the concentration of free carriers therein.

In one embodiment each of the first and second pairs of electrodes (111,112) and (113,114) in each modulating subsystem 121 may constitute a coplanar transmission line that is differentially driven from one end and is terminated at the other end with a suitable line termination 117 so as to suppress back reflections.

The electrodes 111 and 114 of each of the modulating sections 121 may also be referred to as the outer electrodes, and the electrodes 112 and 113—as the inner electrodes. Each electrode 111, 112, 113, or 114 of any one of the N electrode subsystems 121 is spaced apart from the electrodes of the adjacent modulating section 121 so that each of the modulating sections 121 can be dual-differentially driven separately from other modulating sections, as described hereinbelow. The electrodes 111-114 of all three modulating subsystems 121 together can be viewed as separate segments of four non-contiguous electrodes extending along most of the length of the two waveguide arms, and may be referred to as the electrode segments. In the illustrated embodiment each of the electrodes 111, 112, 113, and 114 is of a substantially same length l, but in other embodiments the electrode length may differ from one modulating section 121 to another. The MZM 110 may also include one or more bias electrodes which are not shown in FIG. 2 in order not to obscure the drawing and its description.

In one embodiment, the waveguides of the MZM 110 and the plurality of electrodes 111-114 are formed in or upon a same face of a substrate 99 that may be made with an electro-optic and/or semiconductor material. The term substrate as used herein encompasses multi-layer structures also known as wafers. In one embodiment, the substrate 99 may be made with a semiconductor material, such as for example Silicon (Si), GaAs based, or InP based, or any other suitable semiconductor. In one embodiment, the substrate 99 may be made of a suitable electro-optic material such as but not exclusively LiNbO₃. The substrate 99 may also be referred to herein as the first substrate or the first wafer.

In one embodiment the substrate 99 is a SOI substrate or wafer, with the waveguides forming the MZM 110 having their cores defined in a silicon layer of the SOI substrate 99. In one embodiment a p/n junction or junctions may be formed across each of the waveguide arms 101, 102 in their length portions 115 between the respective electrodes, as

schematically illustrated in FIG. 3 showing a p/n junction **191** in a section of the first waveguide arm **101** by way of example. The p/n junction enables to modulate the refractive index in the waveguide by varying the concentration of free charge carriers therein in response to an applied voltage, thereby forming an optical phase modulator in the waveguide. In one embodiment the p/n junction **191** may be reversed-biased to operate as a carrier depletion based high-speed phase modulator (HSMP). In some embodiment the p/n junction **191** may be in the form of a PIN junction, with an intrinsic (I) region in the middle of the waveguide core sandwiched between a P-doped and an N-doped regions. It will be appreciated that a waveguide MZM with p/n junction based HSPMs in its arms may also be formed in semiconductor materials other than Si, and corresponding embodiments of the EOM **100** are within the scope of the present disclosure.

Turning back to FIG. 2, the EOM **100** may further include a plurality of differential drivers **150** for separately driving each of the modulating section **121** with a respective differential drive signal **151₁**, **151₂**, or **151₃**, and electrical drive circuitry configured so that each MZM arm **101**, **102** in each of the modulating sections **121** can be differentially driven separately from other modulating sections. As illustrated in FIG. 2, this circuitry may include differential electrical signal pathways **123** connecting the first and second pairs of electrodes (**111**, **112**) and (**113**, **114**) in each of the modulating sections **121** to a corresponding differential driver **150**, so that an *i*th modulating section **121_i** is driven by an *i*th differential drive signal **151_i**, *i*=1, 2, or 3. Although illustrated as continuous, in some embodiments the electrical signal pathways **123** may be configured to provide AC coupling of the differential drive signals **151_i**, or selected single-ended components thereof, to some or all of the electrodes **111-114**, for example by including one or more capacitors. The electrical signal pathways **123** may be formed at least in part upon the same substrate as the electrodes **111-114**, or may be provided on a separate driver chip. In some embodiments the electrical driving circuit of the EOM **100**, which includes the differential drivers **150** and an input feed circuit **145**, may be implemented in part or in full on the same substrate **99** as the waveguides **101**, **102** and the electrodes **111-114**. In some embodiments an additional DC bias voltage may be provided to one of the electrodes in each electrode pair **111**, **112** and **113**, **114** from a DC bias source (not shown in FIG. 2). In some embodiments one or more of the electrical drive circuits that connect to each of the electrode subsystems **121** may include two differential drivers configured to generate two complementary pairs of single-ended signals for differentially driving the first pair of electrodes (**111**, **112**) and the second pair of electrodes (**113**, **114**), for example as described hereinbelow with reference to FIGS. 9, 17, and 18. The term ‘differential signal’ is understood herein to mean a signal formed by two single-ended electrical signals having complementary AC components. The differential drive signals **151₁**, **151₂**, and **151₃**, which may generally be referred to as the differential signals **151**, may be characterized by a peak-to-peak voltage swing *V*_{pp}. In one embodiment *V*_{pp}=2*V*_{max} where *V*_{max} is a peak-to-peak voltage swing of each of the complimentary single-ended signals forming the differential drive signal **151**.

The EOM **100** may further include an electrical input port **141** configured to receive an input data signal **13**, and an input feed circuit **145** that connects the electrical input port **141** to each of the electrical drivers **150**. Each of the *N* electrical drivers **150** may be configured to convert the input

electrical data signal **13** into the respective differential drive signal **151_i**, *i*=1, . . . , *N*, which is then provided to each of the electrode pairs (**111**, **112**) and (**113**, **114**). In one embodiment the differential drivers **150** are linear, in the sense that their outputs are linear functions of their inputs. In one embodiment, each of the differential drivers **150_i** may be configured to have an independently adjustable gain so as to output the differential drive signal **151_i** with an independently adjustable amplitude.

In some embodiments the input feed circuit **145** may further be configured to provide the input data signal **13** to each of the *N* differential drivers **150** with a different time delay Δt_i , which may be selected so as to synchronize the provisioning of the differential electrical drive signals **151_i** to the consecutive modulating sections **121** with the propagation of the input light **11** along the first and second waveguide arms **101**, **102**. In one embodiment the input feed circuit **145** may include one or more, for example (*N*-1), delay lines **140** to provide the desired time delays Δt_i in the delivery of the input data signal **13** to the respective differential drivers **150**, and further to the modulation sections **121** in the form of the respective differential drive signals **151_i**. In one embodiment, the delay lines **140** may be independently adjustable.

Turning now to FIG. 4, there is illustrated an example dependence of a modulation bandwidth of an MZM formed in a SiP chip with depletion-mode HSPMs upon the electrode length *l*. At high frequencies the pairs of electrodes sandwiching the modulator’s arms each form a transmission line along which the modulating drive signal **151** propagates. Due to parasitic resistance and capacitance associated with the transmission line, the longer the drive signals has to travel along the transmission line formed by the modulator’s electrodes, the smaller is the attainable modulation bandwidth of the MZM. These parasitic resistance and capacitance in the illustrated example of a SiP EOM originate primarily from the reversed-biased p/n junction forming the HSPM, but may have a different origin in other embodiments. The modulation bandwidth (BW) of a SiP EOM driven using a single-segment transmission line may be estimated as

$$BW \propto \sqrt{\frac{1}{C_{pn}R_{pn}Z_oL}} \quad (1)$$

where *C*_{pn} and *R*_{pn} are the parasitic capacitance and resistance of the reverse-biased PN junctions, *Z*_o and *L* are the characteristic impedance and length of the transmission lines. By way of example, a target modulation bandwidth of 35 GHz may require the length *l* of the electrodes to be no more than 1 mm for an example EOM of FIG. 4 embodied with silicon waveguides and depletion-mode p/n junction HSPMs. However, efficient modulation of the propagating light with a target peak-to-peak voltage *V*_{pp} may require a substantially greater electro-optic interaction length in the waveguide arms. Advantageously, by using two or more separate electrode subsystems **121** of suitably small length *l* disposed one after another along the waveguide arms, both the target modulation bandwidth and a maximum attainable OSNR level at the modulator output may be simultaneously achieved. Accordingly, in one embodiment the length *l* of the electrodes **111-114** may be selected based on the target modulation bandwidth, and the number *N* of the electrode subsystems **121** in the optical modulator **100** may be selected based on a peak-to-peak voltage *V*_{pp} that is avail-

11

able from the differential drivers **150** and a target modulation efficiency, or a target OSNR level at the output of the modulator.

Furthermore, by driving each of the electrode pairs **111**, **112** and **113**, **114** in each of the electrode sub-systems **121** with a respective differential signal **151**, the modulation efficiency of each of the modulating sections **121** may be substantially enhanced for the same peak-to-peak voltage swing V_{pp} in the differential signal **151**, as compared to the conventional MZM driving scheme of FIG. 1 wherein the inner electrodes are grounded so that each of the waveguide arms is modulated with a single-ended signal. Advantageously, with the dual-differential driving of each of the electrode subsystems **121** as illustrated in FIG. 2, a two times smaller peak-to-peak voltage V_{pp} may be used to produce the same modulation of the refractive index in each of the waveguide arms as compared to the MZM of FIG. 1.

In some embodiments it may be desirable to keep the peak-to-peak voltage $V_{pp}=2V_{max}$ of the differential drive signal **151** below a specific value. In some embodiments, V_{pp} may be limited by the peak-to-peak voltage V_{max} of each single-ended component of the differential drive signal **151** that is available from the drive electronics. By way of example, in embodiments wherein the differential drivers **150** are fabricated using the BiCMOS technology, V_{max} may be limited by a breakdown voltage of a Si-based NPN transistor, which is about 1.8V and thus may necessitate using V_{max} smaller than 1.8V, for example 1.5V, yielding a maximum attainable V_{pp} of about 3V to 3.5V. Advantageously, the dual-differential driving scheme of the type illustrated in FIG. 2 or FIG. 9 described hereinbelow enables to obtain a same modulation efficiency with a two times smaller total length of the electrodes $L=N \cdot l$ for a given V_{pp} value, as compared to the differential driving scheme of FIG. 1.

In some embodiments, both the V_{pp} and L may be limited by requirements on the EOM design so that the modulation efficiency that is achievable from the EOM is less than theoretically possible; this may be understood by noting that the modulation efficiency of an MZM is a function of a ratio $k=V_{pp}/V\pi$ of the peak-to-peak voltage V_{pp} of the differential drive signal to the $V\pi$ voltage of the MZM, which is generally inversely proportional to the total electrode length L . The term "modulation efficiency" may refer to the optical modulation amplitude (OMA) in case of the OOK modulation when the MZM may be biased at a mid-point of its transmission characteristic, or to the optical power of BPSK modulated light at the modulator output in case of the BPSK modulation, when the modulator is biased at a transmission minimum. It can be shown that for the OOK modulation the maximum modulation efficiency is achieved for $V_{pp}=V\pi$ for the differential drive scheme of FIG. 1, and for $V_{pp}=V\pi/2$ for the dual differential modulation as illustrated in FIG. 2. For $V_{pp}/V\pi$ smaller than about 0.4, the dual-differential modulation yields an improvement in modulation efficiency of 2-3 dB. For the BPSK modulation the maximum modulation efficiency is achieved for $V_{pp}=2V\pi$ for the differential drive scheme of FIG. 1, and for $V_{pp}=V\pi$ for the dual differential modulation as illustrated in FIG. 2. For $V_{pp}/V\pi$ smaller than about 0.5, the dual-differential modulation yields an even greater improvement in modulation efficiency of 5-6 dB.

By way of example, an embodiment of the modulator device **100** with the MZM formed in a SiP chip with depletion-mode HSPMs, three electrode subsystems **121**, and the electrode length l of 1 mm in each subsystem **121**,

12

and the dual-differential driving with $V_{pp}=2V_{max}=3V$ provides a 35 GHz bandwidth at an optimum OSNR.

Turning now to FIGS. 5 and 6, there is schematically illustrated an example photonics chip **301** wherein the MZM **110** and three electrode subsystems **121**, $i=1, 2, \dots, 3$, are formed upon a first substrate **99**, with the differential drivers **150** formed upon a second substrate **88**. Referring first to FIG. 5, in the illustrated embodiment each of the modulating subsystems **121** further includes a first contact terminal **131** and a second contact terminal **132**, and electrical signal paths **137** that connect the first contact terminal **131** to one electrode of each of the first pair of electrodes (**111**, **112**) and the second pair of electrodes (**113**, **114**), and which further connect the second contact terminal **132** to the other electrode of each of the first and second pairs of electrodes (**111**, **112**) and (**113**, **114**). The pair of contact terminals **131**, **132** function as a differential input port from which a differential drive signal **151** may be fed to each of the first and second pairs of electrodes (**111**, **112**) and (**113**, **114**). In the illustrated embodiment, the first contact terminal **131** in each modulating subsection is connected to the outer electrodes **111** and **114**, while the second contact terminal **132** is connected to the inner electrodes **112**, **113**. The contact terminals **131**, **132** may be embodied in a variety of ways that enable electrical connections between the photonics chip **301** and the driver chip **302**, including but not limited to metalized contact pads, bond wires, or metal pillars.

Referring to FIG. 6, a modulator driver chip **302** that is configured to operate with the photonics chip **301** may include the plurality of differential drivers **150** $_i$, $i=1, \dots, N$, one for each of the N modulating sub-sections **121** of the photonics chip **301**, each of which configured to generate a differential drive signal **151** at a differential output port formed by a pair of contact terminals **171**, **172**. The driver chip **302** may further include an input signal port (not shown) for receiving an electrical data signal **13** as illustrated in FIG. 2, and a feed circuit (not shown) to provide the received data signal to the differential drivers **150** $_i$, as described hereinabove with reference to FIG. 2.

When the chips **301**, **302** are assembled together, for example using hybrid integration, the N pairs of contact terminals **171**, **172** of the driver chip **302** are electrically connected to the respective N pairs of input contact terminals **131**, **132**, for example by flip-chip mounting or wire bonding, so as to provide the differential drive signals **151** $_i$ from each of the N electric drive circuits **150** $_i$ to each of the first and second pairs of electrodes (**111**,**112**) and (**113**,**114**) of the respective modulating subsystem **121** of the photonics chip **301**.

By way of example, the photonics chip **301** may be a SiP chip with the first substrate **99** in the form of a SOI substrate or wafer, and the driver chip **302** may be a CMOS or BiCMOS chip flip-chip mounted on top of the SiP chip **301** so that the contacts terminals **131**, **132** of each of the three modulating sections **121** are in direct contact with the respective contact terminals **171**, **172** of the corresponding driver **150** of the driver chip **302**, for example using metal pillars.

FIGS. 2 and 5 illustrate example EOM embodiments wherein the outer electrodes **111**, **114** within each modulating subsystem **121** are electrically connected to each other and may also be connected to a first contact terminal **131**, and the inner electrodes **112**, **113** are electrically connected to each other and may also be connected to the second contact terminal **132**, so that in operation the inner electrodes **112**, **113** are driven by a first single-ended signal component of the modulating drive signal **151**, and the outer

electrodes **111**, **114** are driven by a second single-ended signal component of the modulating drive signal **151** that is complimentary to the first single-ended component. It will be appreciated however that in other embodiments the four electrodes **111-114** in each modulating subsystems **121** may be connected and driven in a different way, for example as defined by the relative orientation of the modulating p/n junctions in the first and second waveguide arms.

Turning to FIG. 7 there is illustrated an embodiment of the modulator device **100** that may be substantially as described hereinabove with reference to FIG. 2 but wherein the inner electrodes **112**, **113** in each modulating subsystem **121** are driven in counter-phase by the two complementary single-ended components of the differential drive signal **151**. Similarly, the outer electrodes **111**, **114** in each modulating subsystem **121** are also driven in counter-phase by the two complementary single-ended components of the differential drive signal **151**. FIG. 8 illustrates a corresponding example embodiment of the photonics chip **301** wherein each of the first and second terminals **131**, **132** in each modulating section **121** connects to one inner electrode **112** or **113** and one outer electrode **111** or **114**.

As stated hereinabove, the single-ended components of the electrical signals **151** may be DC coupled or AC coupled to the respective electrodes, with additional DC bias signals optionally added in at least some embodiments. Accordingly, in some embodiments the electrical terminals **131**, **132** may be AC coupled to one or both of the respective electrodes in each of the FIG. 6 and FIG. 8 implementations.

Referring now to FIG. 9, there is schematically illustrated in further detail an example electrical drive circuit **450** that can be used to drive one modulating section **121** of a version of the EOM **100** having p/n junctions based HFPMs in each waveguide arm, according to one embodiment of the present disclosure. A first p/n junction **441** is formed in a length portion of the first waveguide arm **101** located within the modulating section **121**, while the second p/n junction **442** is formed in a length portion of the second waveguide arm **102** located within the modulating section **121**. Although illustrated with a lumped element symbols, the p/n junctions **441**, **442** may extend along the whole length of the respective electrodes **111-114**, or at least a portion of their length. In the illustrated embodiment the electrodes **111**, **113** directly connect to the n-sides of the respective p/n junctions and may be referred to as the cathode electrodes, or simply the cathodes. The electrodes **112**, **114** directly connect to the p-sides of the respective p/n junctions and may be referred to as the anode electrodes, or simply the anodes. It will be appreciated that in other embodiments the first and/or second p/n junctions may have a different orientation relative to each other, for example with the p-side of the second p/n junction **442** on the side of the second inner electrode **113**, which will be the anode electrode, while the second outer electrode **114** becoming the cathode electrode.

The electrical drive circuit **450**, which represents an embodiment of a dual differential driver (DDD), includes two differential drivers **421** and **422** that are DC-coupled to the first and second pairs of electrode **111**, **112** and **113**, **114**, which provide electrical connections to first and second p/n junctions **441**, **442** respectively. In one embodiment the two differential drivers **451**, **452** may be cross-coupled to the first and second electrode pairs (**111**, **112**) and (**113**, **114**), so that each of the two differential drivers **421**, **422** is coupled to one electrode from each of the first electrode pair (**111**, **112**) and the second electrode pair (**113**, **114**). In one embodiment the two differential drivers **421**, **422** may be cross-coupled to the first and second electrode pairs (**111**, **112**) and (**113**,

114), so that one of the two differential drivers **421**, **422** is coupled to the cathode electrodes of the first and second electrode pairs and the other one of the two differential drivers **421**, **422** is coupled to the anode electrodes of the first and second electrode pairs.

A common signal pre-processing circuit **410** may be optionally provided for feeding each of the differential drivers **421**, **422** with the electrical data signal **413**, or a signal related thereto. The signal pre-processing circuit **410** may be, for example, a common differential pre-amplifier or a pre-equalizer.

The differential drivers **421** and **422** may be DC-shifted relative to each other to convert a received electrical data signal **413**, or a signal obtained therefrom by the common circuit **410**, into two synchronous differential signals **451** and **452** with a DC shift therebetween. This DC shift V_{DC} may be selected so that both of the modulating p/n junctions **441** and **442** remain reversed biased as the drive voltage oscillates, so as to operate the p/n junctions **441**, **442** in a depletion mode. The single-ended components of the two synchronous differential signals **451** and **452** are then cross-coupled to form two differential drive signals **461** and **462** that drive the respective p/n junctions **441** and **442**. In one embodiment the second differential drive signal **462** is an inverted version of the first differential drive signal **461**, thereby affecting a dual-differential push-pull modulation of the input light in the modulating section **121**.

In one embodiment the two single-ended complimentary components **4511** and **4512** of the first differential signal **451** from the first driver **421** alternate in counter-phase about a first common-mode voltage level V_{cm1} with a peak-to-peak voltage swing V_{max} . The two complimentary single-ended components **4521** and **4522** of the second differential signal **452** alternate with the peak-to-peak voltage swing V_{max} about a second common-mode voltage level V_{cm2} , in sync with the first differential signal **451**. By selecting the first and second common-mode voltage levels V_{cm1} and V_{cm2} so that the DC shift $V_{DC}=(V_{cm1}-V_{cm2})$ between the differential signals **451** and **452** is equal or greater than V_{max} , so that the single-ended components of the first and second differential signals **451**, **452** alternate in non-overlapping voltage ranges, and cross-coupling them so that the more positive signals are provided to the cathodes **111** and **113** and the more negative signals to the anodes **112** and **114**, each of the first and second p/n junctions **441**, **442** may be operated in a reverse-bias regime.

As illustrated in FIG. 9 by way of example, the two single-ended complimentary components **4511** and **4512** of the first differential signal **451** may alternate between 0V and a positive voltage V_{max} , resulting in the differential voltage changing between 0V and $2V_{max}$. The second driver **422** outputs the second differential signal **452** that is formed of two complimentary single-ended signal **4521** and **4522** that oscillate, in sync with the first differential signal **451**, between a negative voltage $-V_{max}$ and 0V resulting in the differential voltage changing between 0V and $-2V_{max}$ and a negative DC shift $V_{DC}=-V_{max}$ from the first differential signal **421**. The zero voltage level (0V) is assumed to be the voltage level half-way between the higher maximum and lower minimum voltages of the single-ended components of the differential signals **451** and **452**. In the illustrated embodiment, it corresponds to the electric potential at the ground **433**. The differential signals **451**, **452** are cross-coupled to the first and second electrode pairs **111**, **112** and **113**, **114** so that in each electrode pair the cathode electrode of the p/n junction **441** or **442** is fed one of the positive single-ended signals **4511**, **4512** and the anode electrode of

the p/n junction **441** or **442** is fed one of the DC-shifted negative single-ended signals **4521**, **4522**. Thus, in operation the two p/n junctions **441**, **442** are reversed-biased push-pull modulated with the voltage across each of the p/n junction oscillating in counter-phase between 0V and $V_{pp}=2V_{max}$. In the illustrated example embodiment this is assisted by connecting the anode electrodes **112**, **114** to the ground **433**, and by providing a positive DC bias voltage $V_b=V_{max}$ to the cathode-connected electrodes **111**, **113**, with the differential drivers **421**, **422** implemented as current steering circuits. Alternatively, a negative DC bias voltage V_b may be provided to the anode-connected electrodes **112**, **114**. Furthermore, each of the termination voltages (V_{max} for cathodes and 0V for anodes in FIG. 9) could be shifted in the positive or negative direction, as long as the difference between is adequate for maintaining the p/n junction is reverse bias. Advantageously, the illustrated dual-differential DC-coupled modulation scheme provides an effective arm-to-arm phase-modulating voltage swing equivalent to $4V_{max}$ applied to a single electrode.

Turning now to FIG. 10, there is schematically illustrated an embodiment wherein the number N of the modulating subsections 121_i , $i=1, \dots, N$ is greater than 3; although only four such subsystems shown, it will be appreciated that there may be one or more modulating subsystems 121 between a second modulating subsystem 121_2 and the $(N-1)$ st modulating subsystem 121_{N-1} shown in the figure. By increasing the total number N of electrode subsystems, the electrodes in each subsystem can be made shorter for the same modulation efficiency, which however may increase the overall length of the device due to the greater number of gaps between the electrodes of adjacent modulating subsystems. Generally, EOMs with the total number of modulating subsystem $N=10$ and greater may be envisioned.

Advantageously, using separately driven short electrode segments enables to considerably increase the EOM modulation bandwidth while providing a suitably high output modulation power or the OSNR. When short enough, the electrode segments may be modeled separately as lumped elements rather than a transmission line, and may not require terminations. FIG. 15A illustrates a simplified diagram of an electrical circuit driving one electrode segment **111**, with a transistor **344** representing one channel of the differential driver. The electrode segment **111** in the lumped model may be viewed as a capacitive load and modelled as a capacitance C_{load} , yielding an equivalent circuit diagram illustrated in FIG. 15B. The modulation bandwidth BW is then controlled by the RC (resistor-capacitor) time constant $\tau=R \cdot C_{load}$. The resistance R in the illustrated example may be estimated as approximately equal to an inverse of the transconductance g_m of the transistor **344**, $R \sim 1/g_m$, so that

$$BW = \frac{g_m}{C_{load}} \quad (2)$$

Thus, the modulation bandwidth of the multi-section EOM with short electrode segments may be substantially increased by increasing the transconductance of the differential driver and/or reducing the electrode capacitance C_{load} , for example by reduce the segment length. When the multi-section electrode design is combined with the dual-differential driving architecture described hereinabove, both the overall number N of electrode subsystems and the length l of each electrode segment can be reduced, leading to a reduction of power or an increase of bandwidth.

Turning now to FIG. 11, there is schematically illustrated an embodiment of the modulation device **100** which includes an MZM **210** with multiple modulating subsections and which may be generally as described hereinabove with reference to FIG. 2 and FIG. 7, but with the input feed circuit **145** additionally including a pre-equalization circuit (EQ) **180** connected in the path of the input data signal **13**. From the output of the pre-equalization circuit **180** the pre-equalized input data signal **13** is fed, with suitable time delays, to the differential drivers **150**, each of which configured to drive one of the four-electrode modulating subsystems of an MZM **210**, which are not shown in the figure but may be as described hereinabove with reference to FIGS. 2-8. Although only three differential drivers **150** are shown, corresponding to $N=3$ modulating subsystems in the MZM **210** (not shown), in other embodiments there may be as few as two and as many as 10 or even 15 modulating subsystems in the MZM **210**, with the corresponding number of differential drivers **150**. The pre-equalization circuit **180** may be configured to provide a high-frequency pre-emphasis to the input data signal **13** that is then passed to each of the electrical drive circuits **150**, as illustrated in FIG. 4. This pre-emphasis is schematically illustrated in FIG. 12 at **310**, and may be configured to partially compensate for the high-frequency roll-off of the modulation characteristic of the EOM **210**, which is schematically illustrated at **303** in the same figure. This roll-off of the modulation characteristic of the EOM **210** may be associated with bandwidth limitations stemming from various elements in the path of the input data signal, including but not limited to those associated with the modulating subsystem **121** and the preceding electrical circuitry. The high-frequency pre-emphasis may also be used to pre-compensate for bandwidth limitations at an optical receiver side.

Turning now to FIG. 13, there is schematically illustrated another embodiment of the modulation device **100** that may be generally as described hereinabove with reference to FIGS. 2, 7, and 11, but which includes N pre-equalization circuits **152**, with $N=3$ by way of example, each pre-equalization circuit **152** receiving the input data signal **13** and transmitting its output into one of the N differential drivers **150**. Similarly to the pre-equalization circuit **180** of FIG. 10, each of the N pre-equalization circuits **152** may be configured to provide a high-frequency pre-emphasis to the input data signal **13** destined to one of the electrical drive circuits **150** so as to pre-compensate for the high-frequency roll-off of the modulation efficiency associated with the corresponding four-electrode subsystem. One advantage of using N separate equalization circuits as first stages of the differential drivers **150** is the ability to adjust the pre-emphasis separately for each of the modulating subsystems, which may be useful for example in embodiments wherein the length of electrodes differs between the modulating subsystems. In some embodiments, the pre-equalization circuits **152** of the individual modulating sections may be present together with a common pre-equalization circuit **180** illustrated in FIG. 12. Referring to both FIG. 12 and FIG. 13, in some embodiments parameters of the equalization circuits **152** and/or **180** may be selected so as to at least partially compensate for bandwidth limitations of other elements or systems in the signal path preceding or following the EOM.

Turning now to FIG. 14, there is schematically illustrated a simplified circuit diagram of a version of a pre-equalization circuit **401** and a differential driver **402** which may be implemented using BiCMOS process and variants of which may be used in embodiments of the present disclosure. The pre-equalizer stage **401** equalizes a differential input data

signal (IN+, IN-) preemptively with the expectation that the high frequency components of the input data signal will be attenuated by the EOM. By using an emitter-follower or source-follower in the differential driver stage **402**, BPSK and multi-level modulation formats become possible because the output of the driver **402** is kept linear.

Turning now to FIG. **16**, there is illustrated a multi-section EOM **300** with a transmitter-side high-frequency pre-emphasis (TXPE) implemented electro-optically. The EOM **300** includes a multi-section MZM **310** with several modulating subsystems or sections **121** disposed one after another along the length of the MZM arms in the direction of light propagation, which may be configured and operate generally as described hereinabove with reference to EOM **100** and with reference to FIGS. **2-15**. The EOM **300** further includes an additional modulating subsystem or section **221** that is configured for implementing the electro-optic TXPE and may be referred to herein as the equalizing section **221** or equalizing subsystem **221**. In the shown embodiment the equalizing section **221** follows the modulating sections **121** described hereinabove, and may be generally structurally similar to each of the modulating subsections **121**, but with the four electrodes that may in some embodiments be of a different length a than the respective electrodes of the modulating subsections **121**. In operation the equalizing subsection **221** is driven by an inverted differential drive signal **251** from an auxiliary differential driver **250**. The inverted differential signal **251** that drives the equalizing subsystem **250** may be referred to as the equalizing differential signal **251**; it is inverted relative to the modulating differential drive signals **151**, so that for example a high voltage in the differential drive signal **151** corresponds to a low voltage in the differential equalizing signal **251**, and vice versa, thereby affecting a modulation of the input light that subtracts from the modulation of the input light by the modulating subsystem **121**. The pre-equalization operation of the EOM **300** may be understood by noting that ideally the RF modulating signal travelling along the electrodes from one modulating section **121** to another should complete the high-low and low-high transitions within one unit interval (UI), or the duration of one symbol or bit of the input data signal. However, due to the bandwidth limitations the RF modulating signal in each UI disperses and interferes with the adjacent intervals, which could corrupt the modulated signal at the EOM output. This dispersion of a signal from a previous UI, termed modulation signal dispersion, may be countered by adding an inverted copy of the modulated signal that is suitably delayed and weighted. In the frequency domain, this may have the effect of attenuating the low frequency components and boosting the high frequency components, resulting in an effective bandwidth expansion.

The description hereinabove with reference to FIGS. **11-14** relates to embodiments wherein the TXPE is performed in the electrical domain before applying the modulating RF signal to sections of the MZM. However, the electrical domain implementation of the TXPE may be challenging at very high bit rates. In the implementation of FIG. **16**, the input data signal is delayed, inverted and weighted in the electrical domain using a delay line **240** and the differential driver **250**, and an inverted modulating signal is added to the light modulation provided by the modulating subsystems **121** by means of the extra subsystem **221**. The equalization weight depends on the ratio between the length a of the electrodes in the TXPE section **221** and the combined electrode lengths of the main modulating subsystems $L=N \cdot l$. Accordingly, one embodiment may include

selecting the electrode length a in the equalizing section **221** of the EOM **300** so as to at least partially compensate for the modulation signal dispersion associated with a high-frequency roll-off of a light modulation efficiency of the modulating subsystems. In some embodiment the electrode length a in the equalization section may also be selected to at least partially compensate bandwidth limitations of a signal path associated with the EOM, such as bandwidth limitations of electrical circuitry in the path of the input data signal and in the optical signal transmission and reception systems after the EOM. In some embodiments, the equalization weight may further be adjusted by adjusting the gain of the differential driver **250**. The time delay T_p provided by the equalizing delay line **240** is another adjustable parameter that may be tuned at a device calibration stage to optimize the equalization. This time delay T_p may be selected to be slightly greater than the time delay Δt that is required to synchronize the provisioning of the drive signal **251** with the propagation of modulated light along the MZM arms, with the difference $\tau=(T_p-\Delta t)$ representing a tap delay of an electro-optic FIR equalizer that the equalizing section **221** implements. By suitably selecting the tap delay τ , the relative length of the equalizing electrode length a/L , and optionally the gain of the equalizing driver **250**, the modulation bandwidth of the EOM **300** may be increased. In some embodiments one or more of these parameters may also be selected so as to at least partially compensate for bandwidth limitations of other elements or systems in the signal path preceding or following the EOM **300**.

Although in the illustrated embodiment the EOM **300** includes a single equalizing subsystem **221**, in some embodiment additional equalizing electrode subsystems may be added with corresponding delay lines to increase the number of TXPE taps, if desired. Furthermore, although in the illustrated embodiment the equalizing electrode subsystem **221** follows the modulating electrode subsystems **121**, in other embodiments it may precede one or more of the modulating subsystems **121**, and may even be the first electrode subsystem closest to the MZM input optical port, provided that it is driven with a suitably selected time delay relative to the propagation of the optical modulation signal in the MZM arms. By way of example, in embodiments wherein the first electrode subsystem **121₁** is driven with an inverted drive signal to provide the optical pre-equalization, the first delay line **140** in the electrical feed circuit **145** may be configured to provide a time delay T_p that is smaller than the time delay Δt that is associated with the light propagation from the equalizing subsystem **121₁** to the first modulating subsystem **121₂**. In some embodiments of the EOM **300** there may be only a single modulating section **121** that is either followed or preceded by the equalizing section **250**, which may be of a smaller length.

Referring to FIG. **17**, there is schematically illustrated an example electrical drive circuit **550** of an equalizing section **250** of the EOM **300** with p/n junctions based HFPMs, for an embodiment of the EOM **300** in which one or more of the modulating sections **121** are driven as illustrated in FIG. **9**. The equalizing section **250** is similar to the modulating section **121** of FIG. **9**, except that it may be of a different length. The electrical drive circuit **550** of the modulating section **250** is substantially identical to the example electrical drive circuit **450** of a modulating section **121** illustrated in FIG. **9**, with functionally same elements indicated with same reference numerals, and operates generally as described hereinabove with reference to FIG. **9**, except that the outputs of the DC-shifted differential drivers **451** and

452 are inverted, or switched, relative to their outputs in the DDD 450 of a modulating section 121 illustrated in FIG. 9.

Accordingly, for an embodiment of the EOM 300 having a modulating section 121 driven by the DDD 450 of FIG. 9 and an equalizing section 250 driven by the DDD 550 of FIG. 17, in the modulation section 121 light in the first waveguide arm 101 is modulated by the first differential drive signal 461, while in the equalizing section 250 the light in the first waveguide arm 101 is modulated by the second differential drive signal 461. And vice versa, while in the modulation section 121 light in the second waveguide arm 102 is modulated by the second differential drive signal 462, in the equalizing section 250 the light in the second waveguide arm 102 is modulated by the first differential drive signal 462, resulting in a push-pull modulation that is counter-phase to the push-pull modulation in the modulating section 121. Accordingly, the phase modulation of light in the equalizing section 250 is subtracted from the phase modulation of light in the modulating section 121. It will be appreciated that in some embodiments, the gain of the differential drivers 451, 452, and the signal timing in different modulating and equalizing sections of a same EOM may be independently adjustable.

With reference to FIG. 18, there is illustrated an electrical circuit of an example dual-differential driver (DDD) 650, which represents one possible implementation of the DC-coupled electrical drive circuits 450 of FIG. 9 or 550 of FIG. 17. The DDD 650 is configured for DC-coupling to the anode/cathode electrode pairs, and the associated p/n junctions in the first and second waveguide arms, of a modulating section or an equalization section of a sectionalized EOM of the present disclosure. In the illustrated example embodiment the DDD circuit 650 includes a pre-equalization stage or circuit 620 connected between two differential driver circuits or stages 621, 622. The pre-equalization stage or circuit 620 may represent a possible implementation of the common circuit 410 of FIGS. 9 and 17, while the differential driver circuits or stages 621, 622 may be a possible implementation of the differential drivers 421, 422. The three stages 620-622 may have separate supply voltages to reduce the chance of a breakdown or to separately set common-mode voltages. The DDD circuit 650 is similar to the equalizer-driver circuit of FIG. 14 except that it adds the second DD stage 622 at a different common-mode voltage level, as described hereinbelow. The pre-equalization circuit 620 includes a pair of transistors 631, 632 and is configured to provide a high-frequency pre-emphasis to an input differential data signal, with its single-ended components labeled as "IN+" and "IN-", received at the bases of the transistors. The pre-equalization circuit 620, which may be of unity gain, outputs two differential signals at two different common-mode voltage levels: a higher-bias differential signal comprised of two complementary single-ended signals labeled "A" and "B" in the figure, which vary in-phase with the single-ended input data signals IN+ and IN-, respectively, and a lower-bias differential signal comprised of two complementary single-ended signals labeled "C" and "D", with signal C varying in counter phase with IN+ and signal D varying in counter phase with IN-. With the common pre-equalizer stage 620 being of unity gain, $A_v=1$, the AC components of the four outputs A, B, C, and D are equal in amplitude. The common-mode voltage of the higher-bias differential signal (A,B) is defined by the supply voltage Vdd1 and a voltage drop across the load resistors in the collector circuits of the pre-equalizer 620. The common-mode voltage of the lower-bias differential signal (C,D) is defined by the base-emitter voltage drop across the transis-

tors 631, 632 and the common-mode voltage of the input data signal (IN+, IN-). In the context of this specification the common-node voltage of a differential signal may also be referred to as the DC component thereof, in particularly when the common-node voltage is substantially DC, or varies in time much slower than the data rate of the input data signal.

The two DD circuits 621, 622 are buffer circuits configured as linear amplifiers; in the shown example they are implemented as emitter followers but may also be implemented as collector followers in other embodiments. The first DD circuit 621 converts the complementary single-ended signals (A,B) from the pre-equalizer 620 into two complementary single-ended signals denoted OUT2+ and OUT1-, which alternate about an upper bias voltage level Vb1 between a maximum voltage level V11 and a minimum voltage level V10, as illustrated in FIG. 19. The second DD circuit 622 converts the second pair of complementary single-ended signals (C,D) from the pre-equalizer 620 into two complementary single-ended signals denoted OUT1+ and OUT2-, which alternate about a lower bias voltage level Vb2 between a maximum voltage level $V21 \leq V10$ and a minimum voltage level V20, as also illustrated in FIG. 19. The DC bias shift $V_{DCshift} = (Vb1 - Vb2)$ between the differential drive signals 611, 612 is defined by the supply voltages Vdd1, Vdd2, and Vdd3, by the voltage drops across the load resistors in the pre-equalizer 620, and by the base-emitter voltage drop for the transistors 631, 632.

Advantageously, the dual differential drive signals OUT1+, OUT1-, OUT2+ and OUT2- provided by the equalizing DDD circuit 650 can be DC-coupled to the p/n junctions of the waveguide arms of the EOM of the present disclosure. The DC-shifted signals OUT1+ and OUT1- with complementary AC components may be provided as a first differential drive signal for driving one of the two anode/cathode electrode pairs of a modulation or equalization section of an EOM, while the counter-phase DC-shifted signals OUT2+ and OUT2- may be provided as a second differential drive signal for driving the other of the two anode/cathode electrode pairs of the modulation or equalization section of the EOM in counter-phase. By suitably selecting circuit parameters of the DDD 650, such as Vdd1, Vdd2, Vdd3, and values of the load resistors in the pre-equalizer 620, the DC bias shift $V_{DCshift}$ between the differential outputs (OUT1+, OUT1-) and (OUT2+, OUT2-) of DDD 650 may be selected so as to provide the desired reverse biasing and push-pull modulation of two p/n junctions of a modulating section 121 or an equalizing section 250, when the differential outputs of the DD 621, 622 are cross-coupled to the two p/n junctions, or the corresponding pairs of electrodes.

Referring now also to FIGS. 9 and 17 while continuing to refer to FIGS. 18 and 19, by way of example in one embodiment a first pair of complementary signals (OUT1+, OUT1-) from a first instance of DDD 650 may be DC coupled to the first pair of electrodes 111, 112 of a modulating section 121 to drive its first modulating p/n junction 441 to modulate the first waveguide arm 101, while a second pair of complementary signals (OUT2+, OUT2-) is DC coupled to the second pair of electrodes 113, 114 of the modulating section 121 to drive its second modulating p/n junction 542 to modulate the second waveguide arm 102. In EOM embodiments with the electro-optical equalization, such as those described hereinabove with reference to FIG. 16 or FIG. 17, another instance of the DDD circuit 650 in the EOM may be used to drive an equalizing section 250, with the differential outputs inverted relative to that of the modu-

lating section or sections of the same EOM, so that for example the first pair of complementary signals (OUT1+, OUT1-) is DC coupled to the second pair of electrodes **113**, **114** to drive the p/n junction **442** in the second waveguide arm **102**, as shown in FIG. **17**, while the second pair of complementary signals (OUT2+, OUT2-) is DC coupled to the first pair of electrodes **111**, **112** to drive the first p/n junction **441** and modulate the first waveguide arm **101**, so that the modulation of each waveguide arm in the equalizing section of the EOM is effectively subtracted from the modulation of the same waveguide arm in the modulating section of the EOM, with a relative time delay selected to counteract the modulation dispersion.

Advantageously, the dual-differential driver **650** providing two differential drive signals with a DC offset between them enables proper reverse biasing of the two p/n junctions of a modulating section of an EOM and driving them in a push-pull manner with a doubled voltage swing without the need for on-chip bypass capacitors, which may otherwise be needed for DC blocking in embodiments where the DC bias is provided to the electrodes separately from the modulating signal. These on-chip bypass capacitors can be relatively large and therefore would increase the chip area and/or add high parasitic capacitance, which in embodiments described hereinabove is advantageously avoided by the use of DC-shifted differential drive signals.

It will be appreciated that the circuitry of the equalizing DDD **650** of FIG. **18** is shown as an example only, and the DDD **650** may include other circuitry implementing additional techniques, such as for example swing-limiting in order to prevent collector-emitter breakdown in the equalization and emitter-follower (EF) stage.

The above-described exemplary embodiments are intended to be illustrative in all respects, rather than restrictive, of the present invention. Indeed, various other embodiments and modifications to the present disclosure, in addition to those described herein, will be apparent to those of ordinary skill in the art from the foregoing description and accompanying drawings.

For example, it will be appreciated that different electro-optic dielectric materials and semiconductor materials other than silicon, including but not limited to compound semiconductor materials of groups commonly referred to as A3B5 and A2B4, such as GaAs, InP, and their alloys and compounds, may be used to fabricate the optical modulator circuits example embodiments of which are described hereinabove. In another example, although example embodiments described hereinabove may have been described primarily with reference to a waveguide modulator device including an MZM, it will be appreciated that principles and device configurations described hereinabove with reference to specific examples may be adopted to other types of optical waveguide modulators.

Furthermore, although some of the embodiment's described hereinabove use depletion-mode p/n junctions formed in semiconductor waveguides, other embodiments may use forward-biased or non-biased p/n junctions, or use electro-optic properties of the waveguide arms material that do not require p/n junctions to modulate the phase or amplitude of propagating light.

Furthermore, although some of the embodiment's described hereinabove use one or more electrical delay lines in the path of the electrical data signal, in other embodiments such electrical delay lines may be supplemented or replaced with optical delay lines disposed in the waveguide arms between at least some of the successive modulating sections; such optical delays may be employed, for example, to

synchronize the propagation of the modulated light in the waveguides arms with the delivery of the differential driver signals to the modulating segments.

Furthermore, although the dual-differential driver circuit illustrated in FIGS. **9**, **17**, and **18**, which employs two differential drivers that are DC coupled to both the anodes and the cathodes of the p/n junction phase modulators in the two waveguide arms to convert an input data signal into two output differential drive signals with a DC-shift therebetween, has been described hereinabove with reference to a multi-section EOM such as those illustrated in FIGS. **2**, **7**, **10**, and **16**, in other embodiments such a driving circuit may also be advantageously used in non-sectionalized EOM embodiments which employ only a single modulating section, or one modulating section and one equalizing section, and all such embodiments are within the scope of the present disclosure.

Furthermore, FIG. **20** illustrate another example EOM embodiment wherein an MZM **610** is provided with a single modulating section that is driven by a differential driver **650**, which complementary single-ended outputs **651**, **652** are negatively biased and DC coupled to signal electrodes **611** and **614** that are connected to the anodes of the modulating p/n junctions **640**, **642** formed in the waveguide arms **101**, **102** of the MZM **610**. The cathodes of the modulating p/n junctions **640**, **642** may be connected to ground **433**. The negative bias of the single-ended drive signals **651**, **652** may be effected by using a negative supply voltage V_{dd} in the differential driver **650**, which may be embodied for example as schematically illustrated in FIG. **14**. The arrangement wherein the anodes of the modulating p/n junctions are driven by negatively-shifted complementary drive signals while the cathodes are referenced to the ground provides advantages over a scheme wherein the anodes are connected to ground, as it enables to eliminate a bias-T from the driver electronics or the MZM chip. A bias-T, which is commonly used in conventional MZM drivers, may cause signal distortion and/or loss, and is associated with higher cost and size of the modulator chip or module.

Furthermore in the description above, for purposes of explanation and not limitation, specific details are set forth such as particular architectures, interfaces, techniques, etc. in order to provide a thorough understanding of the present invention. In some instances, detailed descriptions of well-known devices, circuits, and methods are omitted so as not to obscure the description of the present invention with unnecessary detail. Thus, for example, it will be appreciated by those skilled in the art that block diagrams herein can represent conceptual views of illustrative circuitry embodying the principles of the technology. All statements herein reciting principles, aspects, and embodiments of the invention, as well as specific examples thereof, are intended to encompass both structural and functional equivalents thereof. Additionally, it is intended that such equivalents include both currently known equivalents as well as equivalents developed in the future, i.e., any elements developed that perform the same function, regardless of structure.

Thus, while the present invention has been particularly shown and described with reference to example embodiments as illustrated in the drawing, it will be understood by one skilled in the art that various changes in detail may be affected therein without departing from the spirit and scope of the invention as defined by the claims.

We claim:

1. An electrical drive circuit for driving a Mach-Zehnder modulator (MZM), the MZM comprising a first waveguide arm coupled to a first anode electrode and a first cathode

23

electrode, and a second waveguide arm coupled to a second anode electrode and a second cathode electrode, the electrical drive circuit comprising:

- a first differential driver for being DC-coupled to the first cathode electrode and the second cathode electrode; 5
 - a second differential driver for being DC-coupled to the first anode electrode and the second anode electrode; and
 - a common feed circuit configured to convert an input differential data signal into two offset differential signals having different common-mode voltage levels, and to feed the two offset differential signals to the first and second differential drivers; 10
- wherein each of the first and second differential drivers comprises a current source. 15

2. The electrical drive circuit of claim **1** comprising:

- a ground, and
- a source of DC voltage that is positive relative to the ground for DC-biasing the first and second cathode electrodes. 20

3. The electrical drive circuit of claim **1** comprising:

- a ground, and
- a source of DC voltage that is negative relative to the ground for DC-biasing the first and second anode electrodes. 25

4. The electrical drive circuit of claim **1** wherein the common feed circuit is configured to convert the input differential data signal into the two offset differential signals having non-overlapping voltage swings.

5. The electrical drive circuit of claim **1** wherein the common feed circuit comprises a unit-gain transistor pair configured to output the two offset differential signals responsive to the input differential data signal. 30

6. The electrical drive circuit of claim **1** wherein the common feed circuit is configured to boost high-frequency components of the input differential data signal. 35

7. The electrical drive circuit of claim **1** wherein at least one of the first and second differential drivers comprises a current-steering circuit.

8. The electrical drive circuit of claim **1** wherein each of the first and second differential drivers comprises a current-steering circuit. 40

9. The electrical drive circuit of claim **1** wherein at least one of the first and second differential drivers comprises one of an emitter follower circuit or a collector follower circuit. 45

10. The electrical drive circuit of claim **1** comprising a ground, wherein the first differential driver is configured to output the first differential signal comprising two single-ended electrical signals alternating between a ground voltage and a first voltage V_{max} that is positive relative to the ground, and the second differential driver is configured to output the second differential signal comprising two single-ended signals alternating between the ground voltage and a second voltage $-V_{max}$ that is negative relative to the ground. 50

11. The electrical drive circuit of claim **10** comprising a source of supply voltage V_{dd} , wherein the common feed circuit is configured to output the offset differential signals having each a peak-to-peak voltage swing that is smaller than V_{dd} . 55

12. The electrical drive circuit of claim **1** wherein each of the first and second differential drivers comprises one of a collector follower circuit or an emitter follower circuit. 60

24

13. An optical modulator device comprising:

- a Mach-Zehnder modulator (MZM) comprising:
 - first and second waveguide arms;
 - first anode and cathode electrodes coupled to the first waveguide arm and having each a first end and a second end; and
 - second anode and cathode electrodes coupled to the second waveguide arm and having each a first end and a second end; and,

an electrical drive circuit comprising:

- a first differential driver DC-coupled to the first and second cathode electrodes and comprising a current source;
- a second differential driver DC-coupled to the first and second anode electrodes and comprising a current source; and
- a common feed circuit configured to convert an input differential data signal into two offset differential signals having different common-mode voltage levels, and to feed the two offset differential signals to the first and second differential drivers. 10

14. The optical modulator device of claim **13**, wherein: the first differential driver is electrically connected to the first ends of the first and second cathode electrodes, and the second differential driver is electrically connected to the first ends of the first and second anode electrodes; the MZM comprises a ground electrode electrically connected to the second ends of the first and second anode electrodes; 15

the electrical drive circuit comprises a positive voltage source connected to the second ends of the first and second cathode electrodes for DC biasing thereof.

15. The optical modulator device of claim **13**, wherein: the first differential driver is electrically connected to the first ends of the first and second cathode electrodes, and the second differential driver is electrically connected to the first ends of the first and second anode electrodes; the MZM comprises a ground electrode electrically connected to the second ends of the first and second cathode electrodes; 20

the electrical drive circuit comprises a negative voltage source connected to the second ends of the first and second anode electrodes for DC biasing thereof.

16. The optical modulator device of claim **14**, wherein each of the first and second differential drivers comprises a current steering circuit.

17. The optical modulator device of claim **15**, wherein the first and second differential drivers comprise each at least one of an emitter follower circuit or a collector follower circuit.

18. The optical modulator device of claim **13**, wherein the first differential driver is configured to output two single-ended electrical signals alternating between a ground voltage and a voltage that is positive relative to the ground, and the second differential driver is configured to output a differential signal comprising two single-ended electrical signals alternating between the ground voltage and a voltage that is negative relative to the ground. 25

* * * * *