



US011057616B2

(12) **United States Patent**
Na et al.

(10) **Patent No.:** **US 11,057,616 B2**
(45) **Date of Patent:** **Jul. 6, 2021**

(54) **VIDEO ENCODING METHOD AND APPARATUS THEREFOR, AND VIDEO DECODING METHOD AND APPARATUS THEREFOR**

(51) **Int. Cl.**
H04N 11/02 (2006.01)
H04N 19/103 (2014.01)
(Continued)

(71) Applicants: **SAMSUNG ELECTRONICS CO., LTD.**, Suwon-si (KR); **SEOUL NATIONAL UNIVERSITY R&DB FOUNDATION**, Seoul (KR)

(52) **U.S. Cl.**
CPC *H04N 19/103* (2014.11); *H04N 19/176* (2014.11); *H04N 19/59* (2014.11)

(72) Inventors: **Sang-kwon Na**, Seoul (KR); **Soo-ik Chae**, Seoul (KR); **Ki-won Yoo**, Seoul (KR); **Jae-moon Kim**, Uiwang-si (KR); **Woo-seok Jeong**, Seoul (KR)

(58) **Field of Classification Search**
CPC *H04N 19/103*; *H04N 19/176*; *H04N 19/59*
(Continued)

(73) Assignees: **SAMSUNG ELECTRONICS CO., LTD.**, Suwon-si (KR); **SEOUL NATIONAL UNIVERSITY R&DB FOUNDATION**, Seoul (KR)

(56) **References Cited**
U.S. PATENT DOCUMENTS

5,262,854 A 11/1993 Ng
8,111,914 B2 7/2012 Lee et al.
(Continued)

(*) Notice: Subject to any disclaimer, the term of this patent is extended or adjusted under 35 U.S.C. 154(b) by 441 days.

FOREIGN PATENT DOCUMENTS

CN 103609112 A 2/2014
CN 103765893 A 4/2014
(Continued)

(21) Appl. No.: **15/735,042**

OTHER PUBLICATIONS

(22) PCT Filed: **Jun. 8, 2016**

Communication dated Aug. 26, 2019, from the State Intellectual Property Office of People's Republic of China in counterpart Application No. 201680033861.7.

(86) PCT No.: **PCT/KR2016/006025**

§ 371 (c)(1),
(2) Date: **Dec. 8, 2017**

(Continued)

Primary Examiner — Jayanti K Patel
Assistant Examiner — Richard B Carter
(74) *Attorney, Agent, or Firm* — Sughrue Mion, PLLC

(87) PCT Pub. No.: **WO2016/200124**

PCT Pub. Date: **Dec. 15, 2016**

(57) **ABSTRACT**

Provided is a video decoding method including obtaining a residue of a first bit-depth with respect to a current block by decoding a bitstream; when intra predicting the current block, generating a prediction block of the current block by using a block that is previously decoded at the first bit-depth and then stored in a buffer; and generating a reconstruction block of the first bit-depth by using the prediction block and

(65) **Prior Publication Data**

US 2020/0036966 A1 Jan. 30, 2020

(Continued)

(30) **Foreign Application Priority Data**

Jun. 9, 2015 (KR) 10-2015-0081530

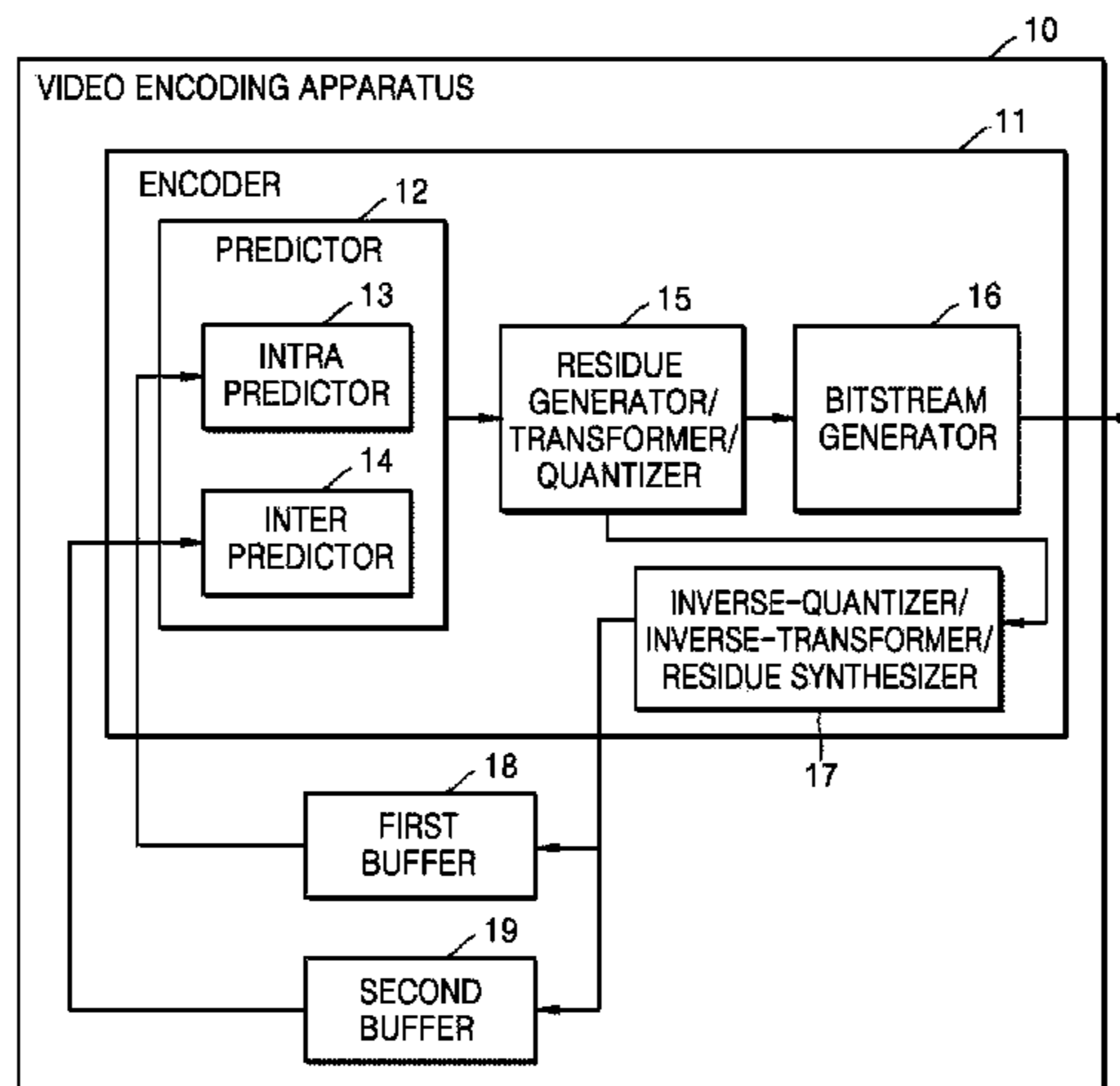

the residue of the first bit-depth. When the current block is inter predicted, the video decoding method may further include generating a prediction block of a second bit-depth by using an image previously decoded at the second bit-depth, and generating the prediction block of the current block by changing the generated prediction block of the second bit-depth to the first bit-depth. The first bit-depth is higher than the second bit-depth.

7 Claims, 34 Drawing Sheets

- (51) **Int. Cl.**
H04N 19/176 (2014.01)
H04N 19/59 (2014.01)
- (58) **Field of Classification Search**
 USPC 375/240.02, 240.13, 240.14, 240.25
 See application file for complete search history.

(56) **References Cited**

U.S. PATENT DOCUMENTS

8,553,767	B2	10/2013	Koto et al.	
9,510,016	B2	11/2016	Gomila et al.	
9,521,434	B2	12/2016	Chen et al.	
9,888,242	B2	2/2018	Alshina et al.	
2008/0170615	A1*	7/2008	Sekiguchi	H04N 19/70 375/240.14
2011/0243232	A1	10/2011	Alshina et al.	
2011/0255608	A1*	10/2011	Kim	H04N 19/186 375/240.25

2015/0124865	A1*	5/2015	Kim	H04N 19/103 375/240.02
2016/0198175	A1	7/2016	Shima et al.	
2016/0261884	A1*	9/2016	Li	H04N 19/176
2016/0261885	A1*	9/2016	Li	H04N 19/587

FOREIGN PATENT DOCUMENTS

CN	107690806	A	2/2018
JP	2012-129650	A	7/2012
JP	2012-134878	A	7/2012
JP	2014-131172	A	7/2014
JP	2015-95833	A	5/2015
KR	10-2007-0097309	A	10/2007
KR	10-2011-0028351	A	3/2011
KR	10-2014-0019474	A	2/2014
KR	10-1362757	B1	2/2014
KR	10-2016-0144845	A	12/2016
WO	2016200124	A1	12/2016

OTHER PUBLICATIONS

International Search Report and Written Opinion dated Sep. 1, 2016, issued by the International Searching Authority in counterpart International Application No. PCT/KR2016/006025 (PCT/ISA/210 & PCT/ISA/237).
 Communication dated Jun. 23, 2017, issued by the Korean Intellectual Property Office in counterpart Korean Application No. 10-2015-0081530.
 Communication dated Sep. 30, 2016, issued by the Korean Intellectual Property Office in counterpart Korean Application No. 10-2015-0081530.

* cited by examiner

FIG. 1A

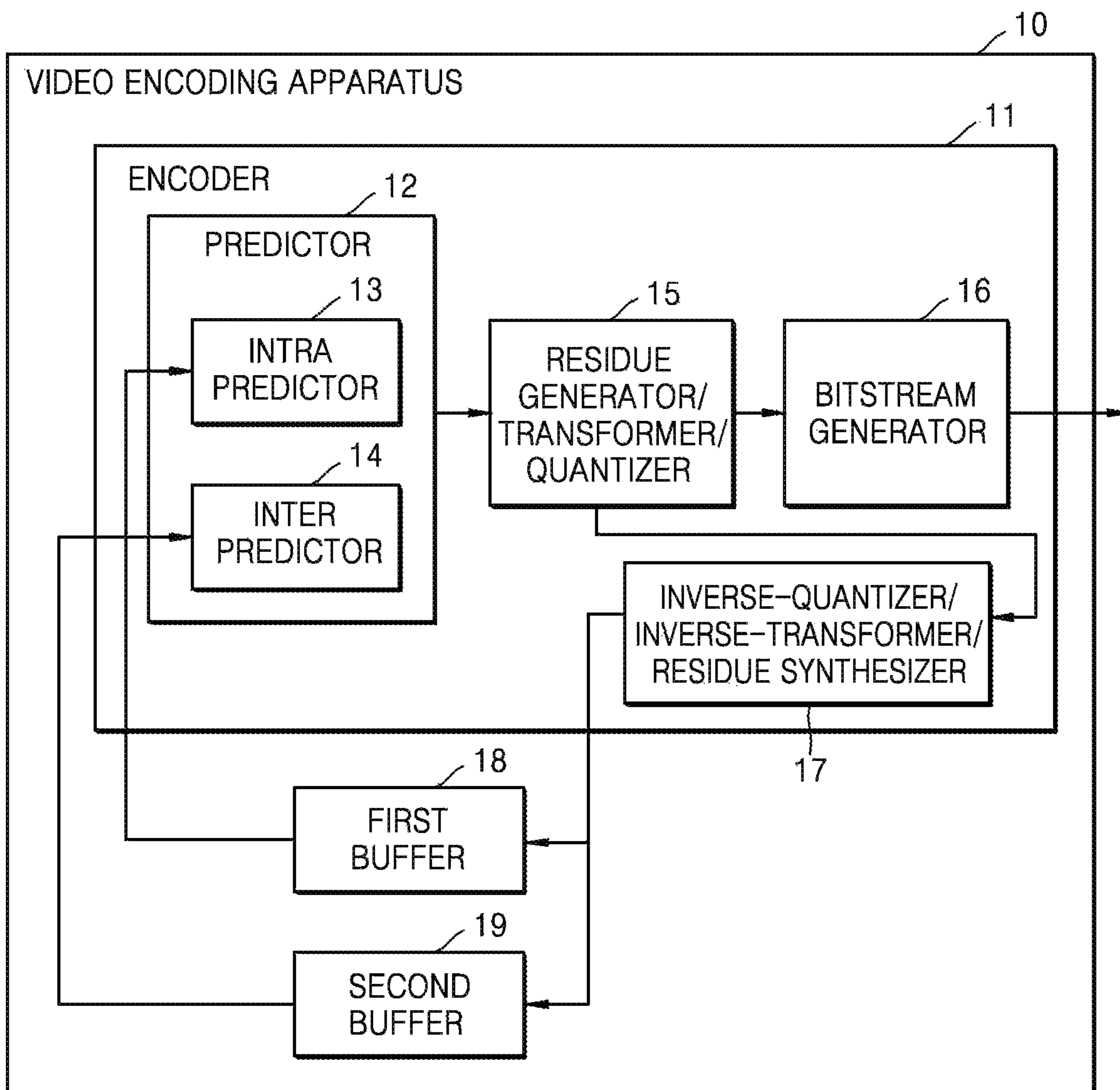

FIG. 1B

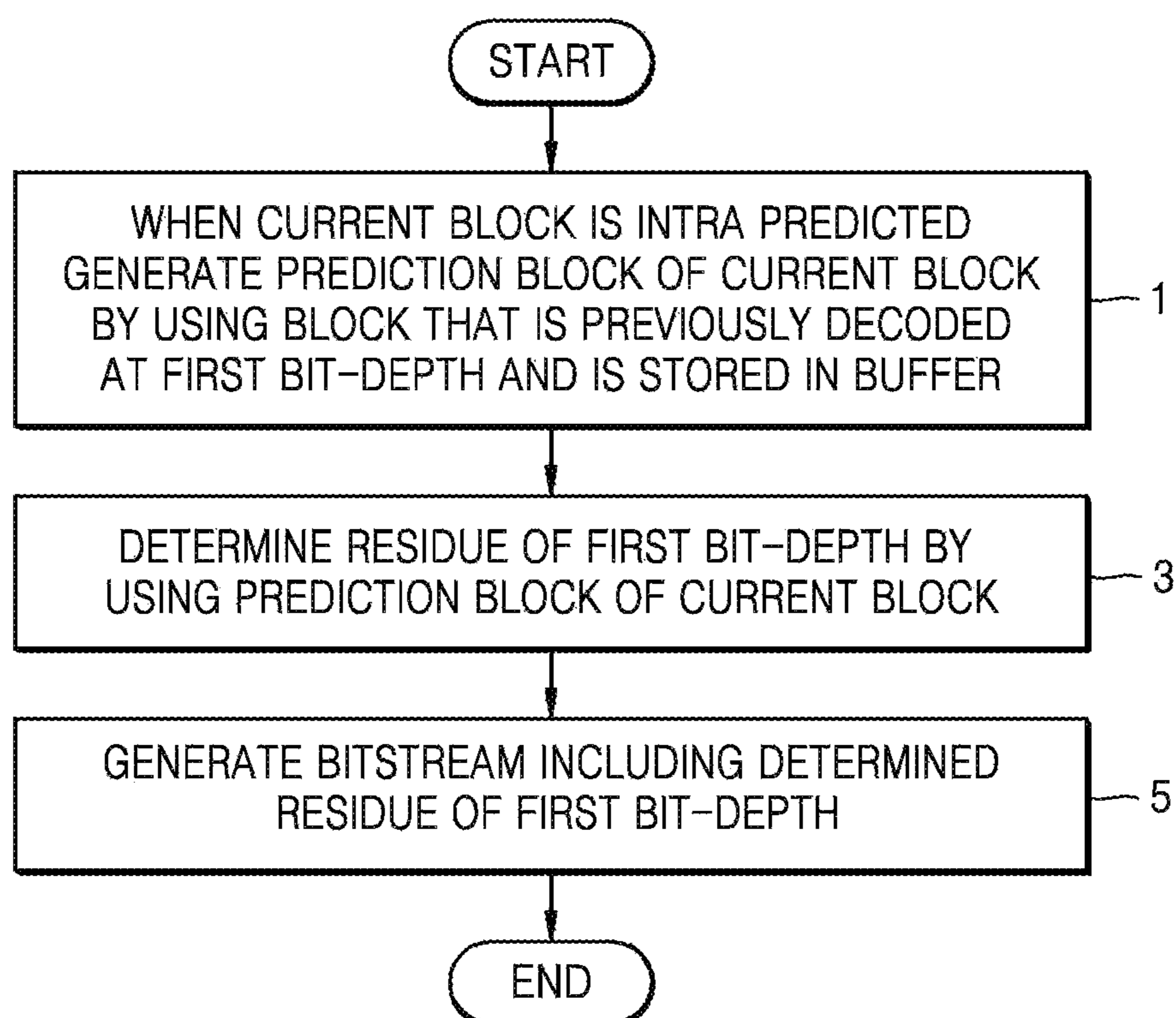

FIG. 1C

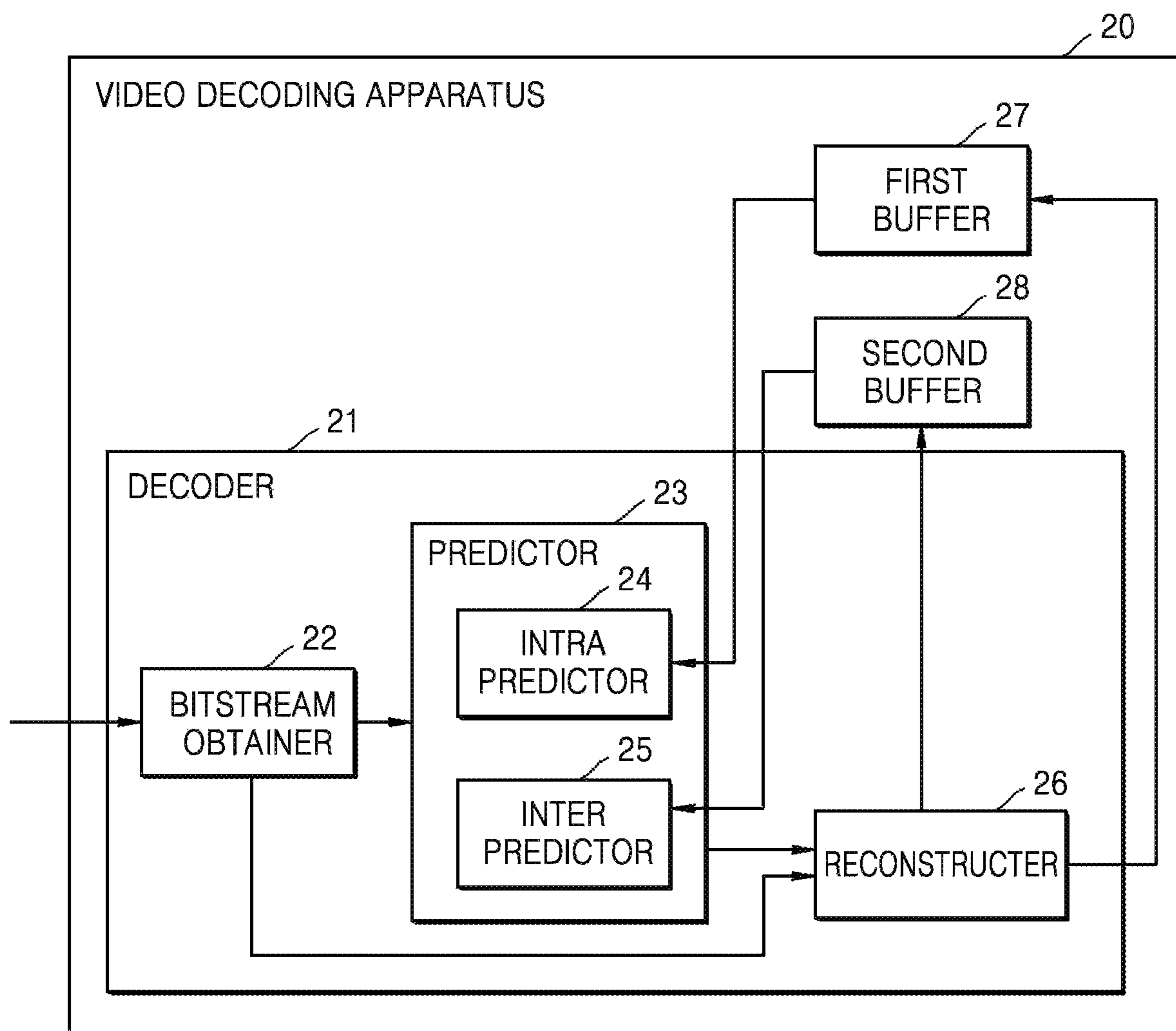

FIG. 1D

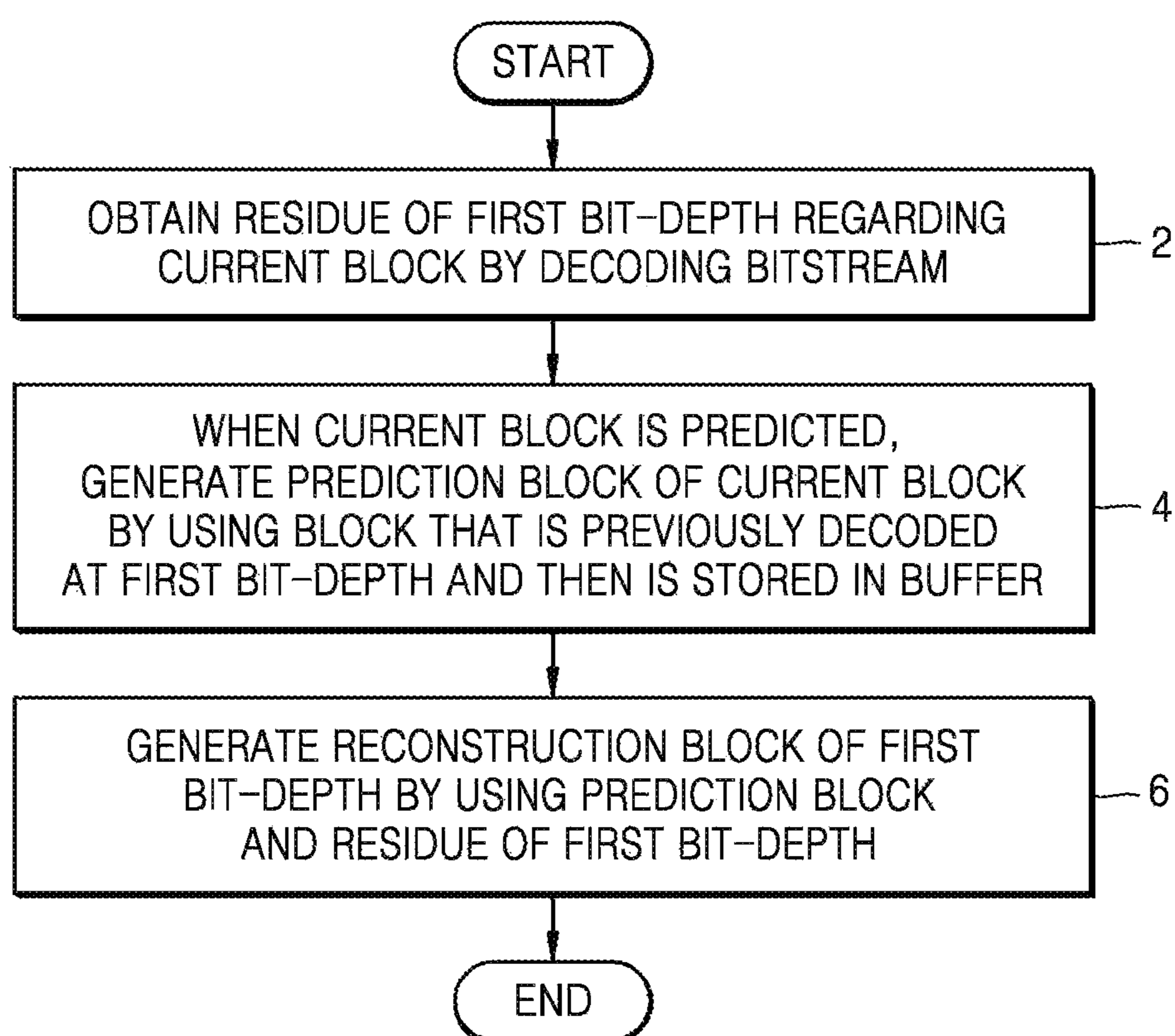

FIG. 2A

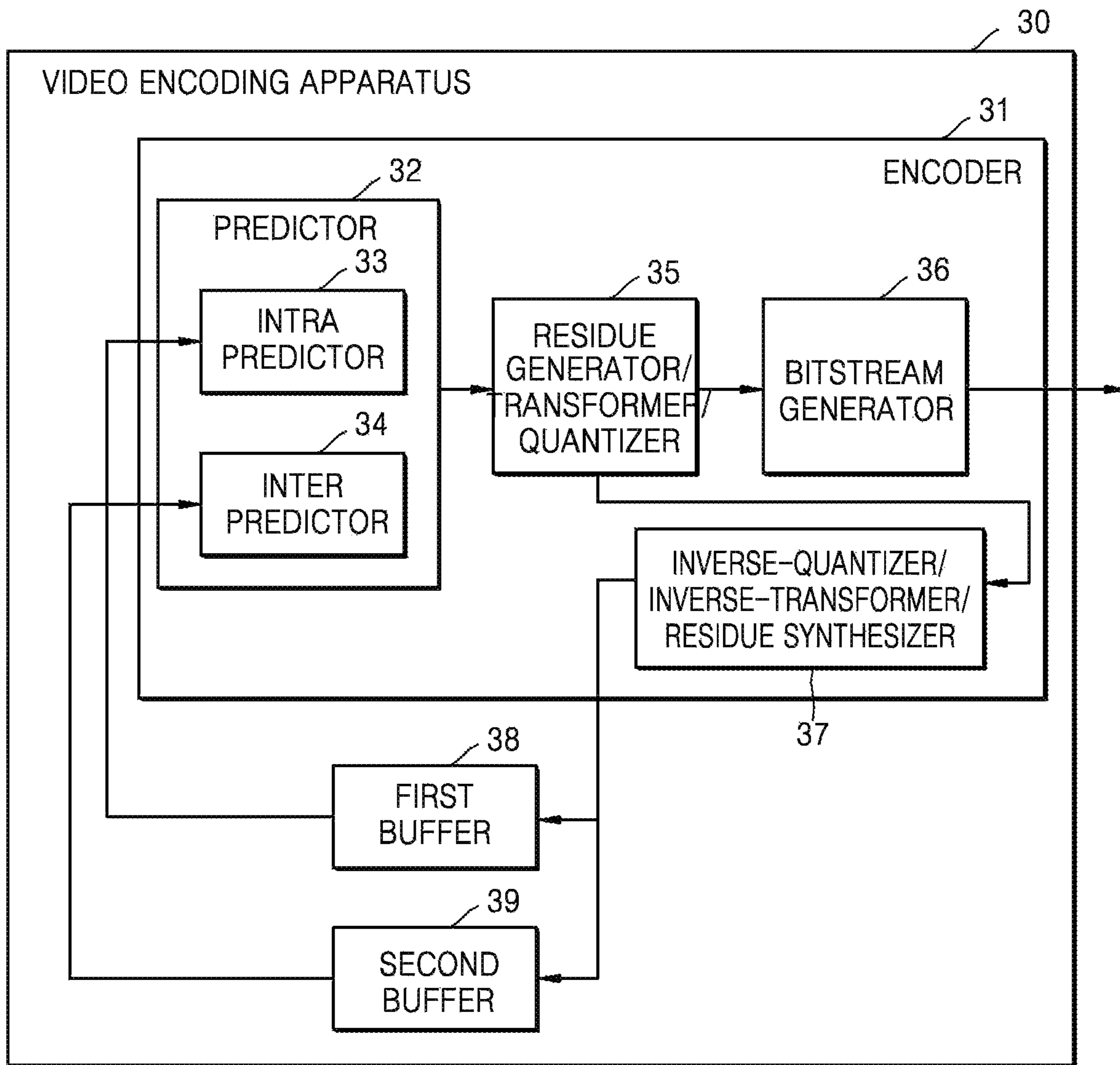

FIG. 2B

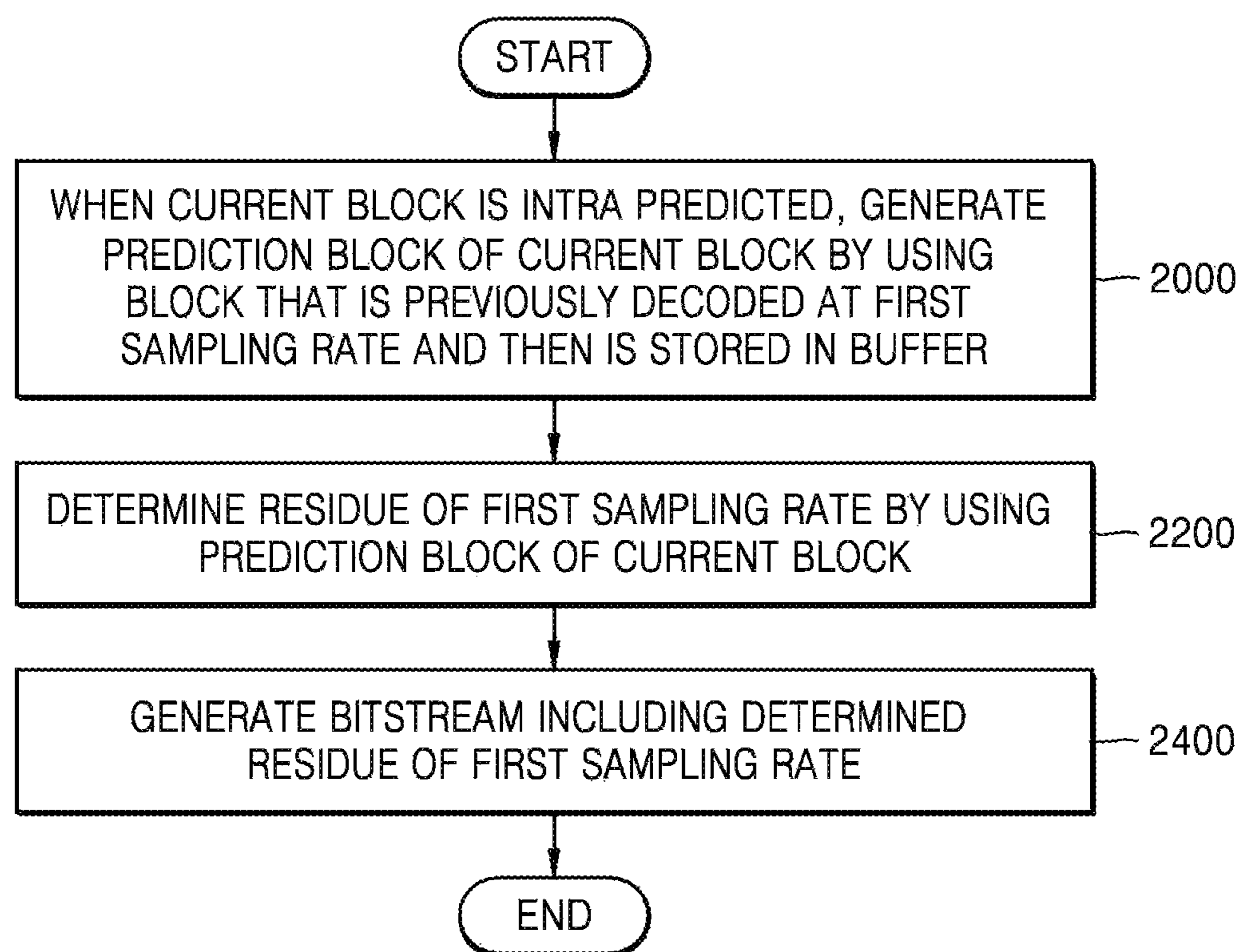

FIG. 2C

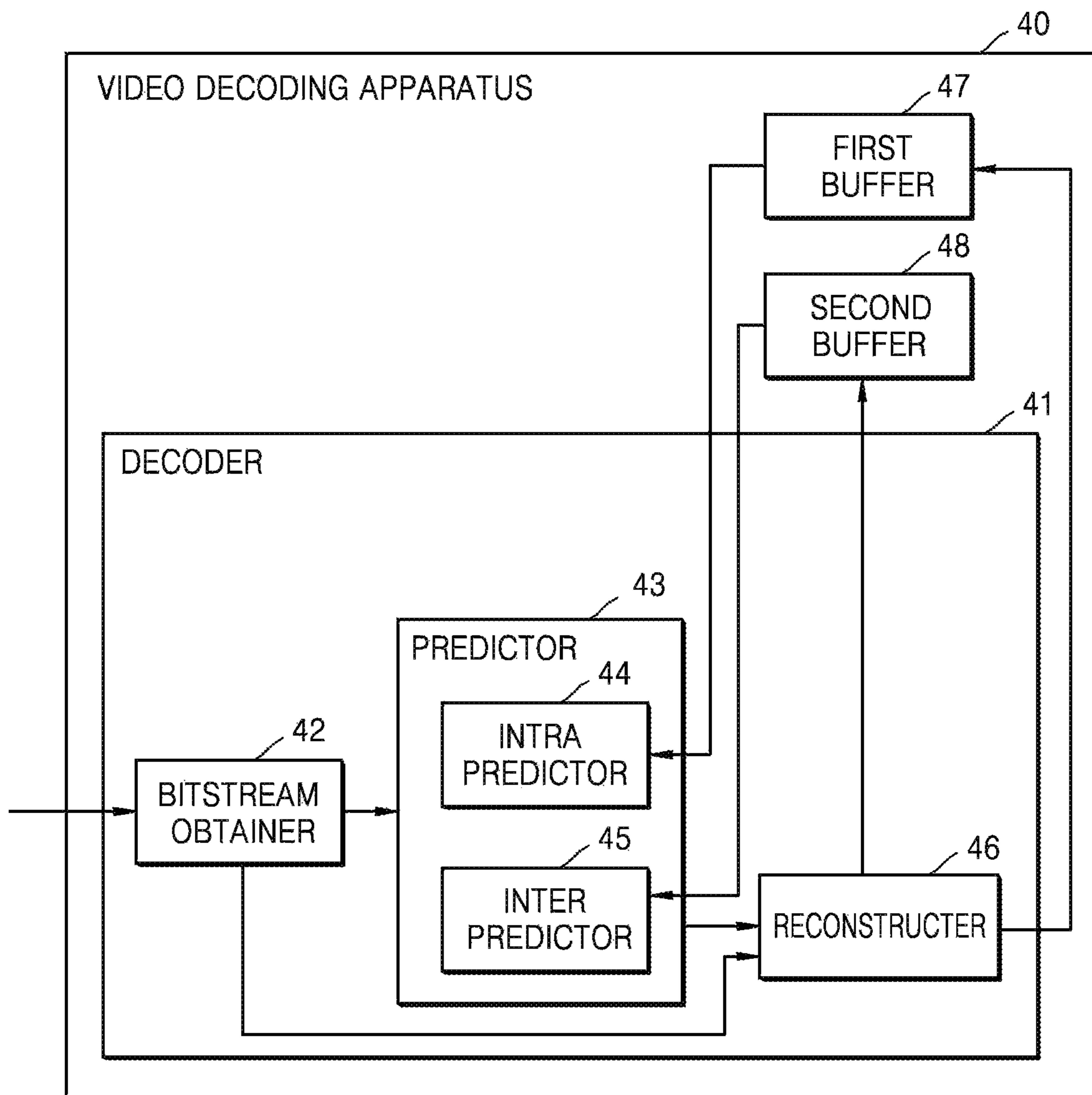

FIG. 2D

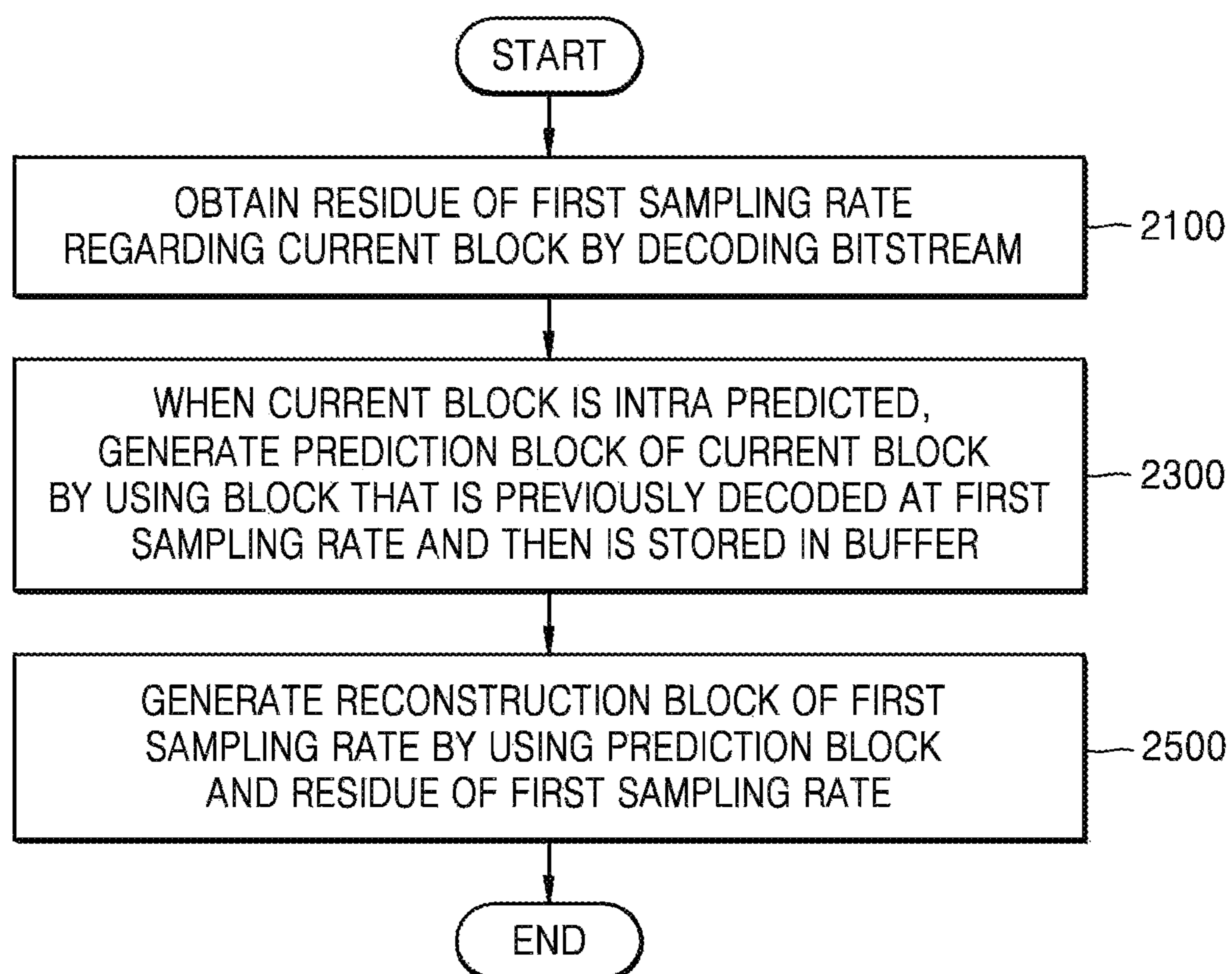

FIG. 3

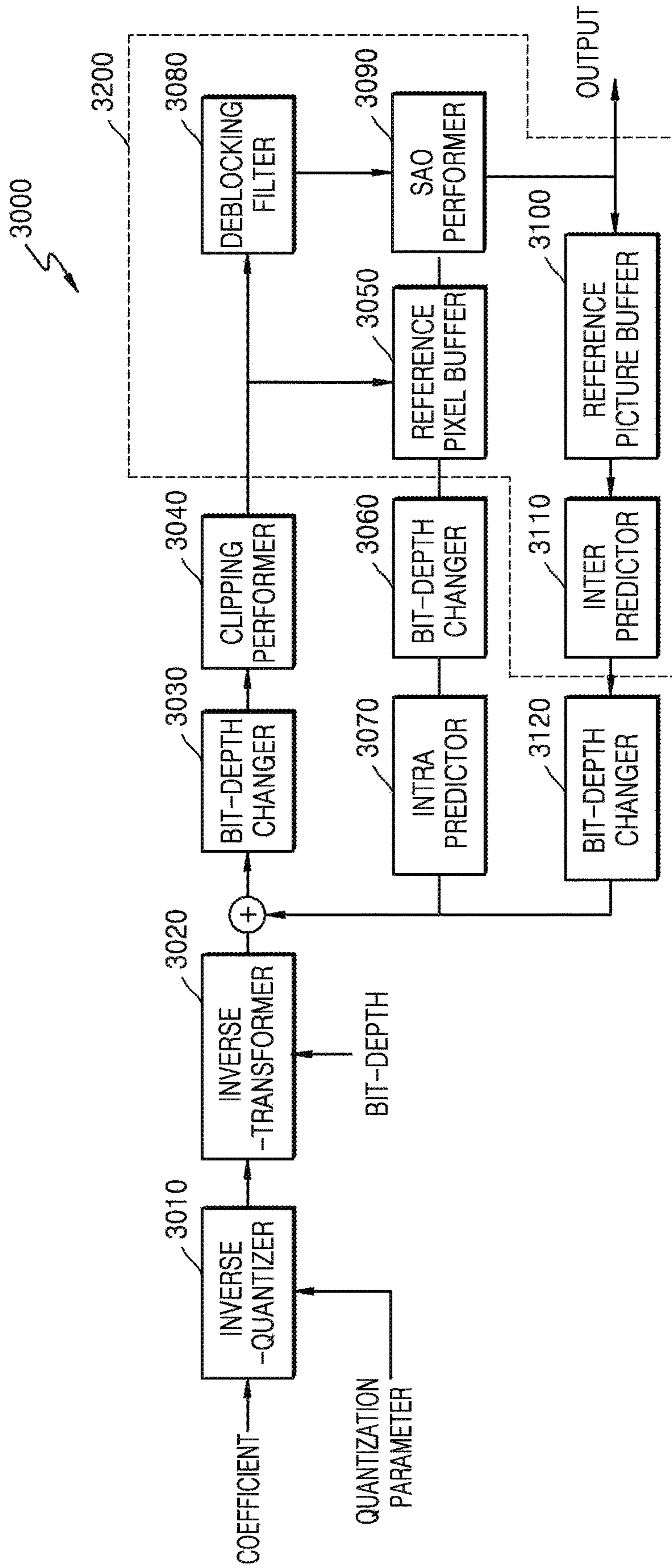

FIG. 4

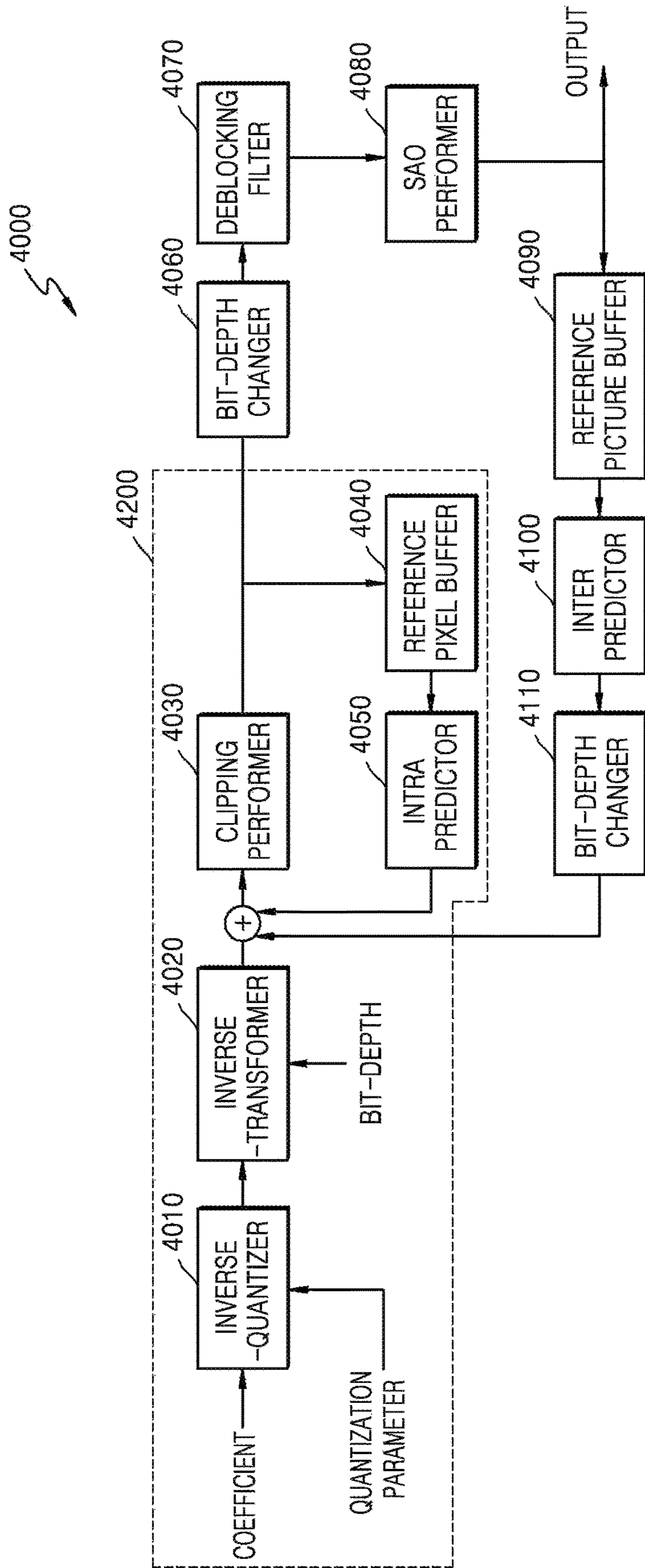

FIG. 5

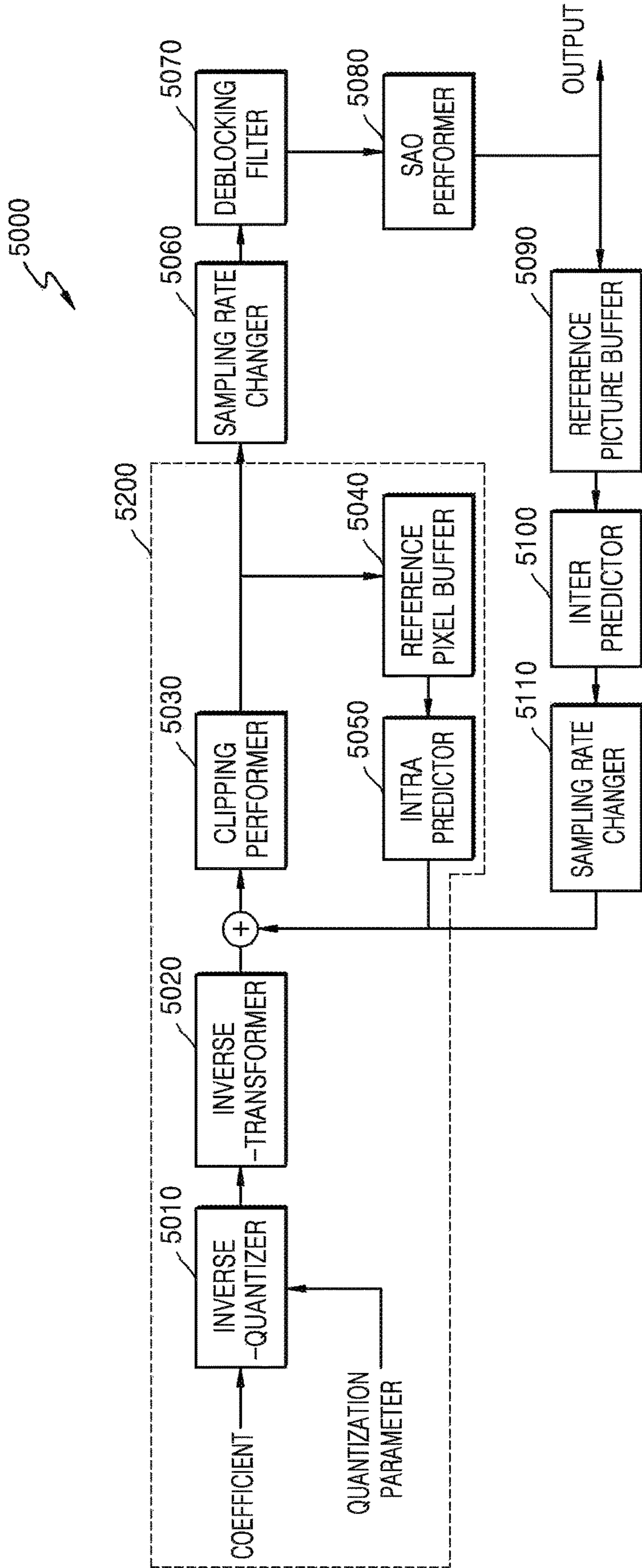

FIG. 6A

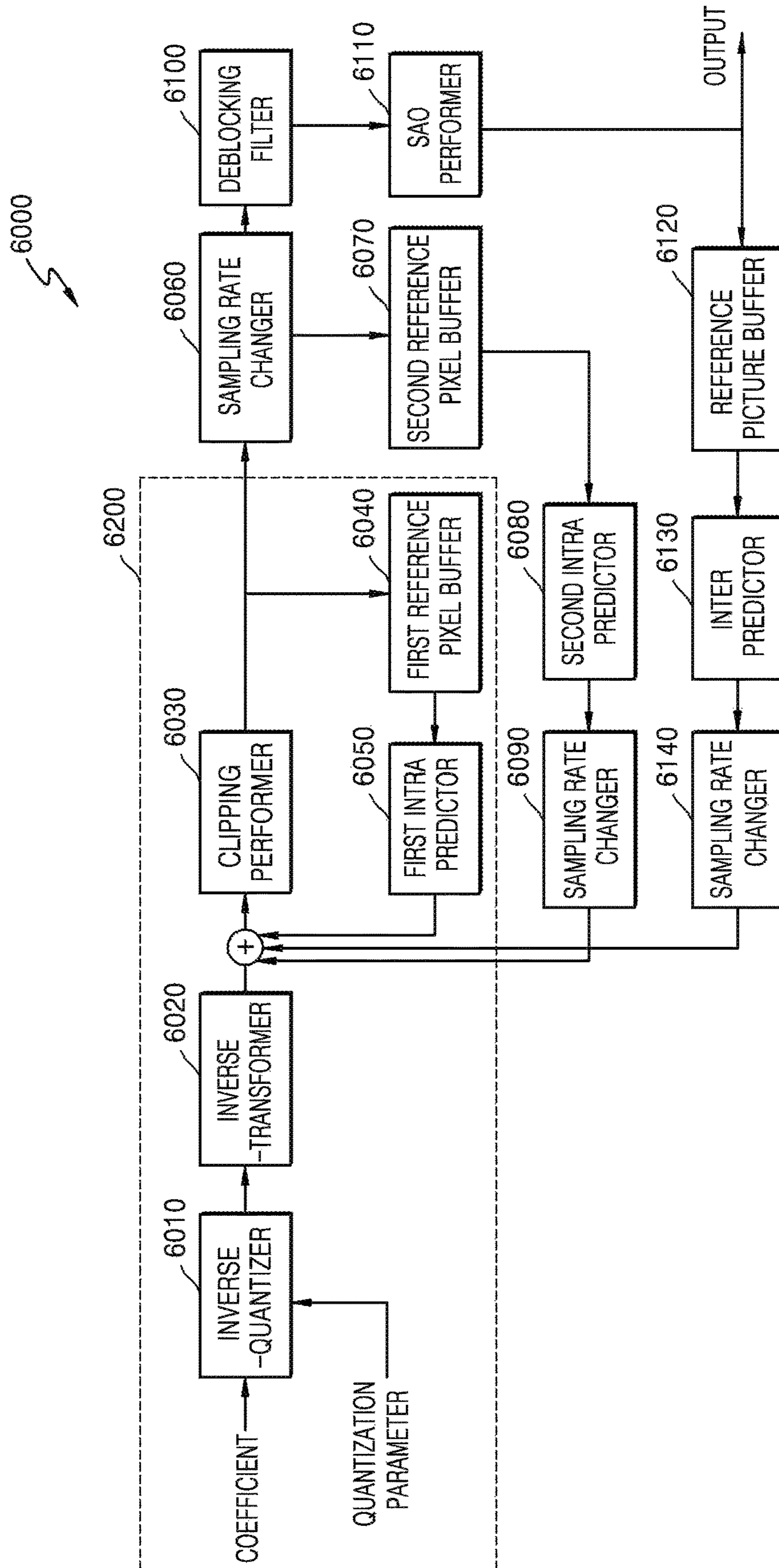

FIG. 6B

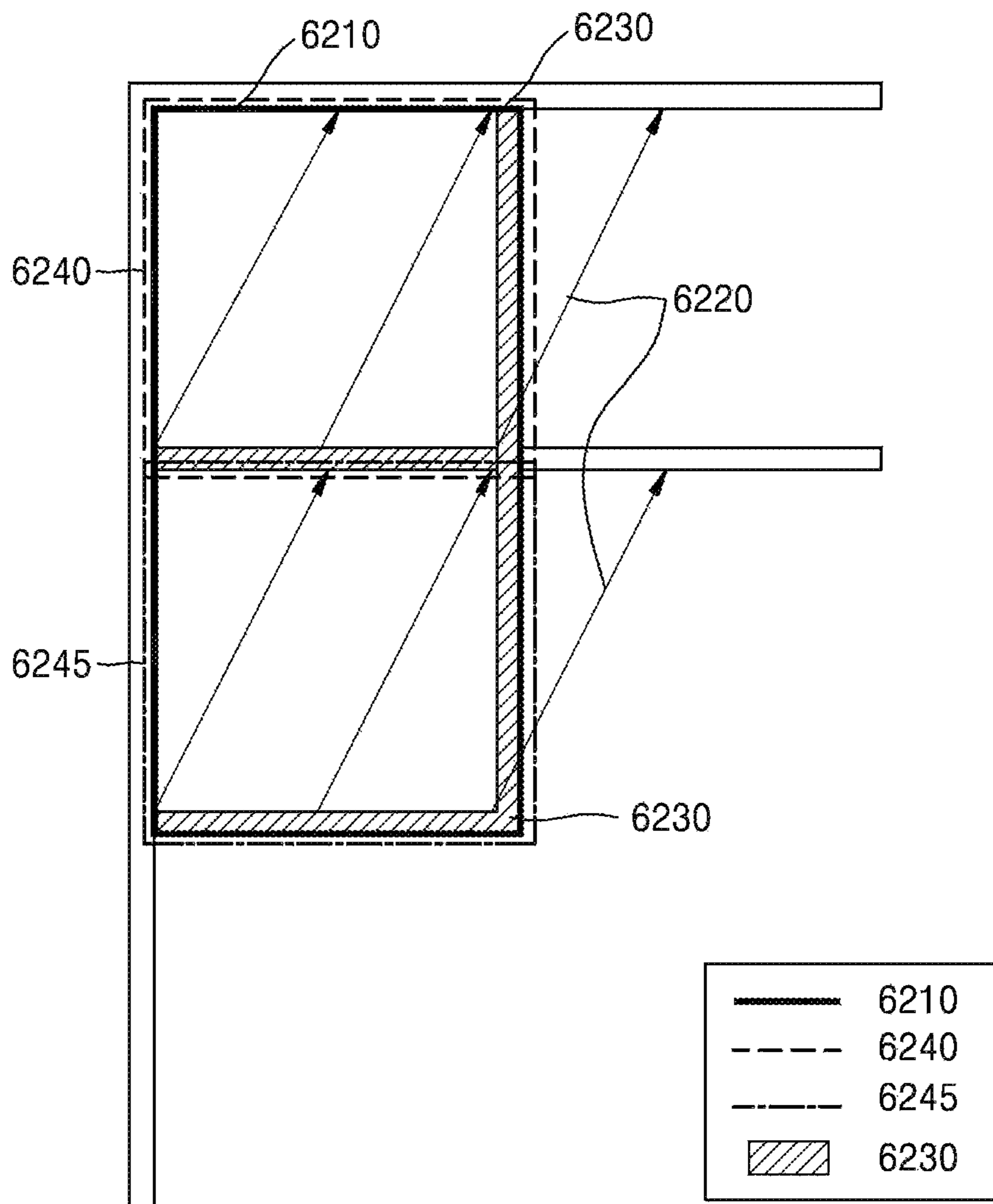

FIG. 6C

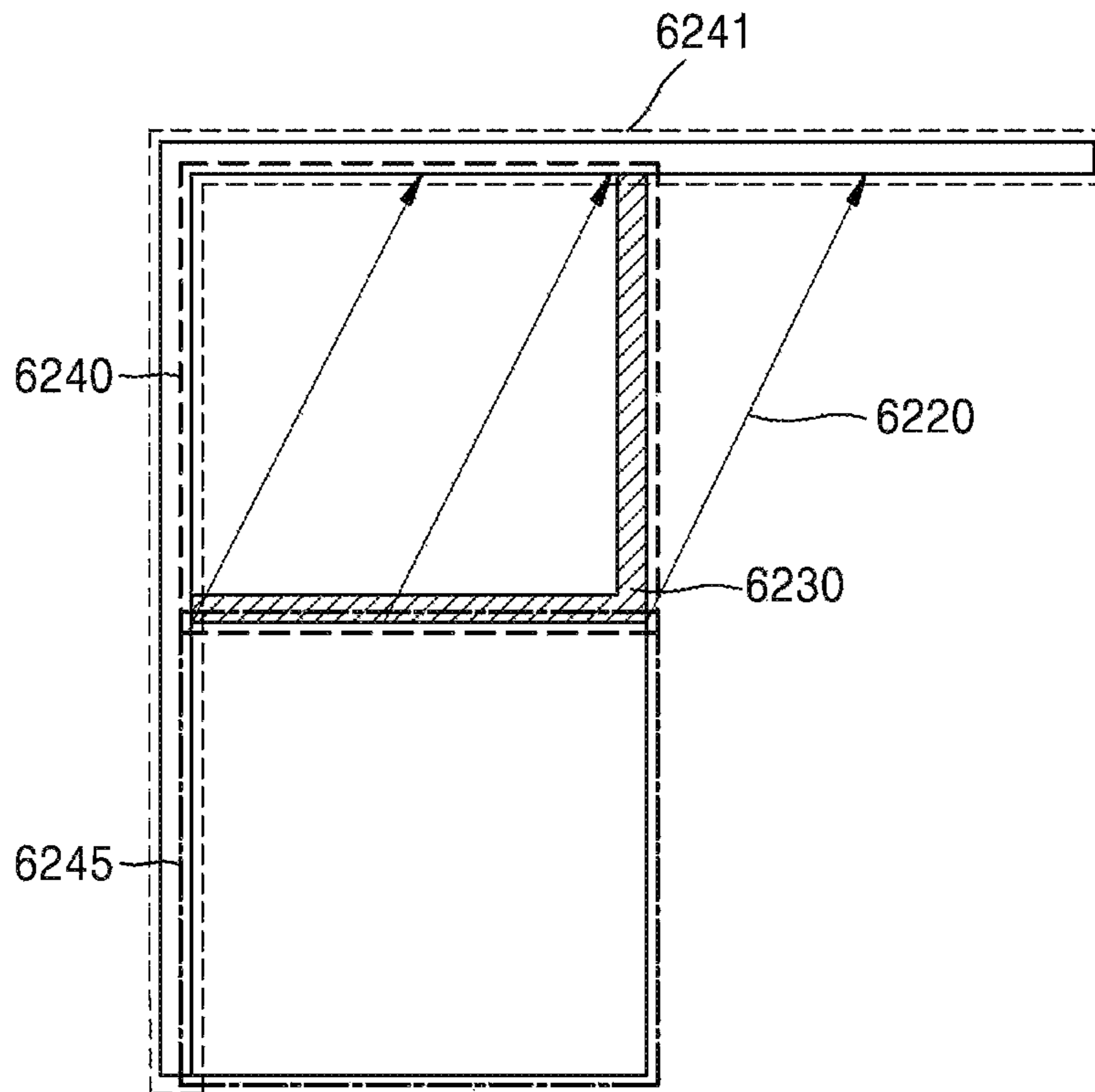

FIG. 6D

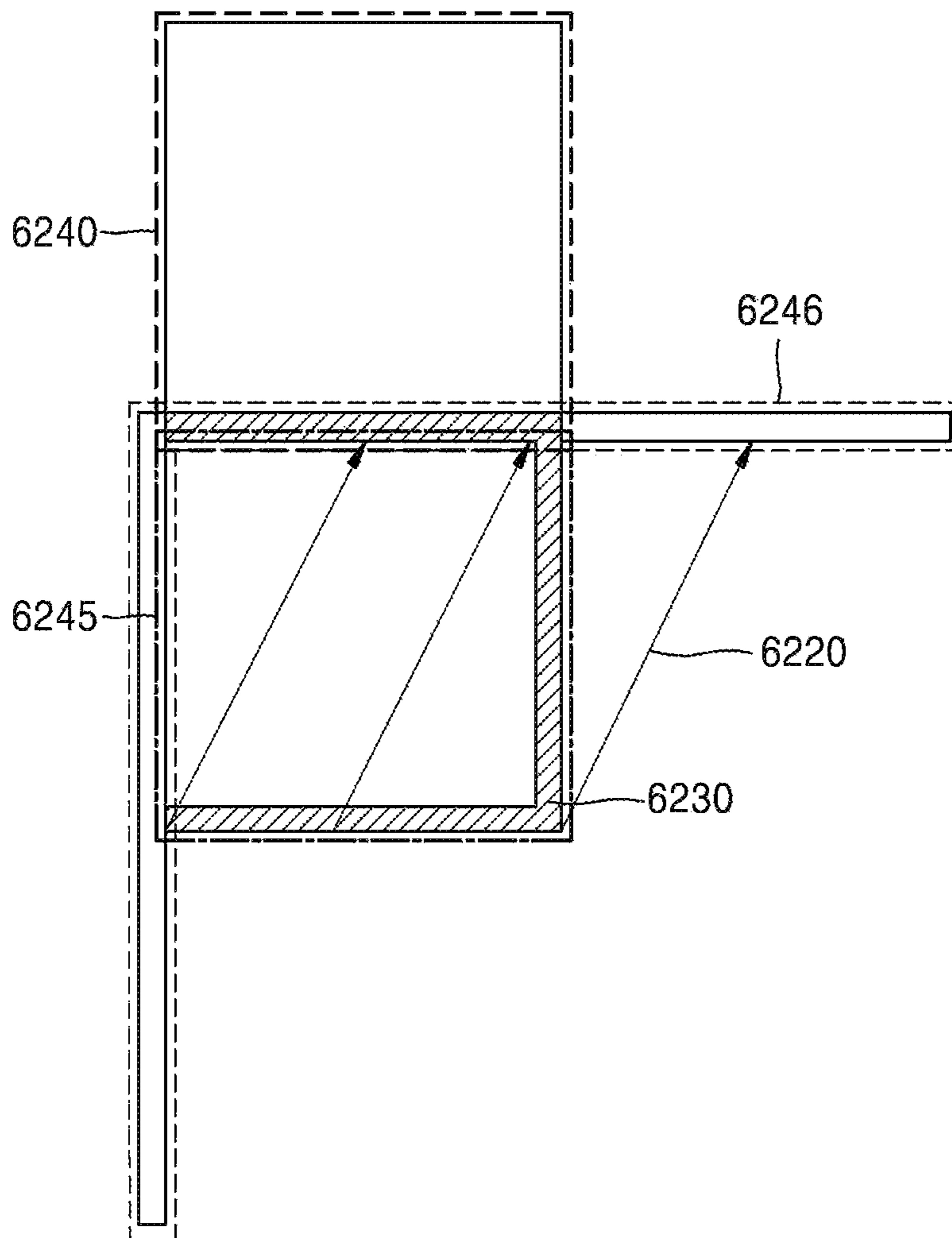

FIG. 6E

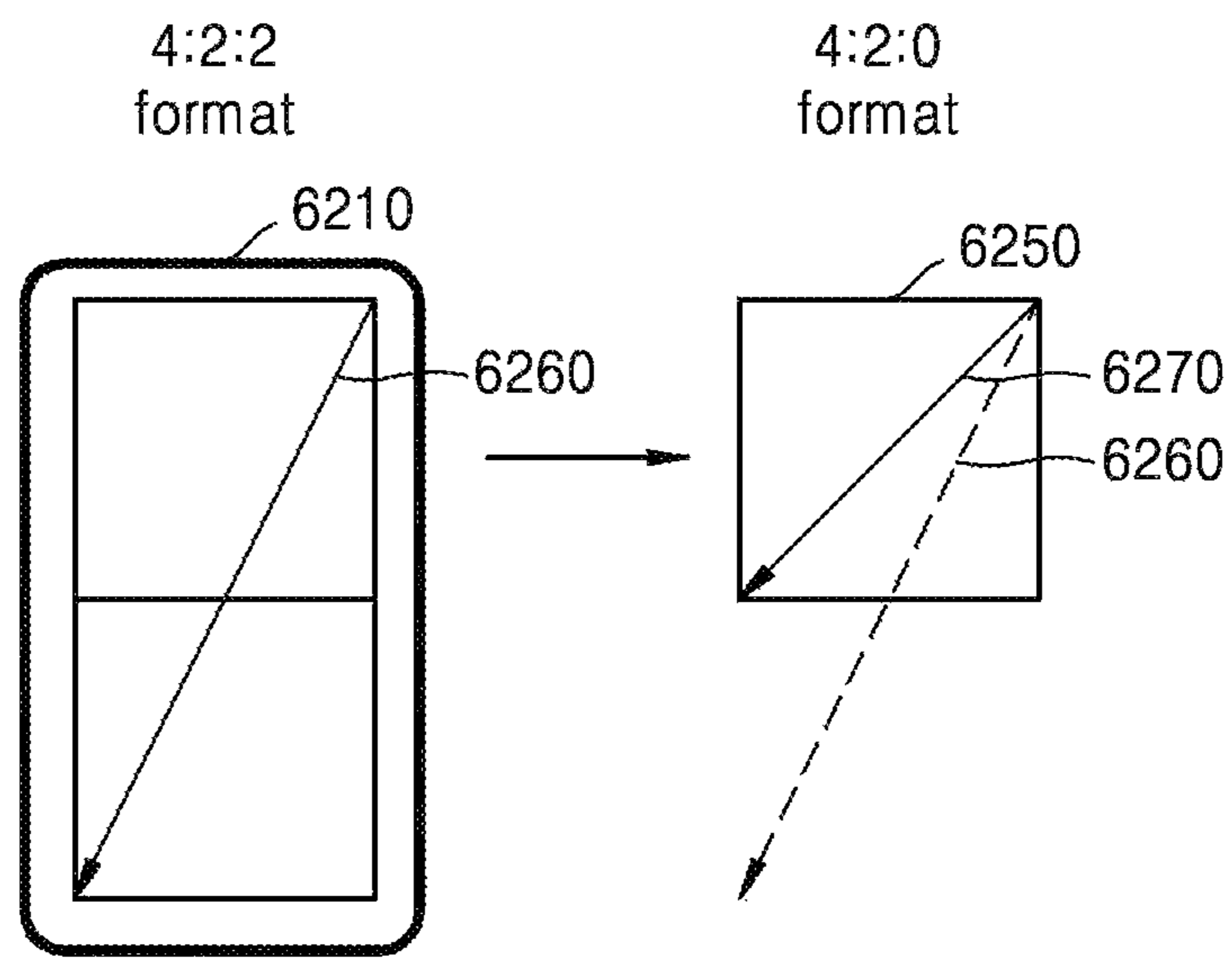

FIG. 7

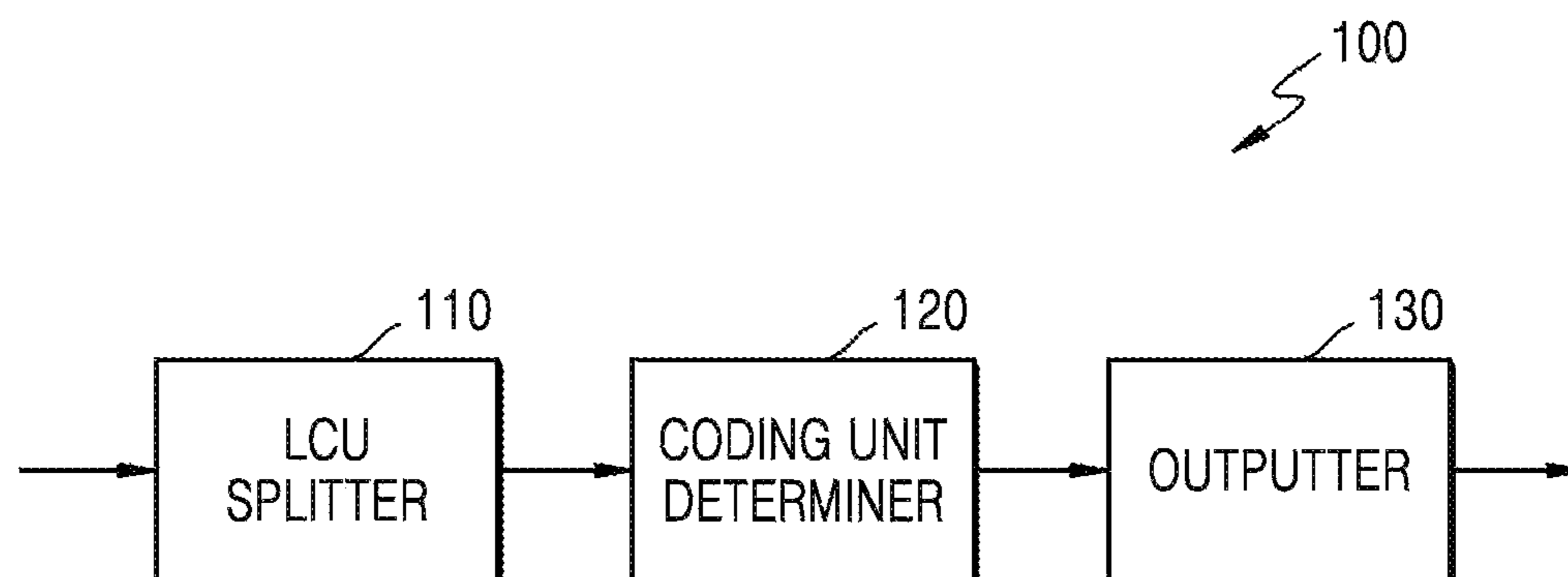

FIG. 8

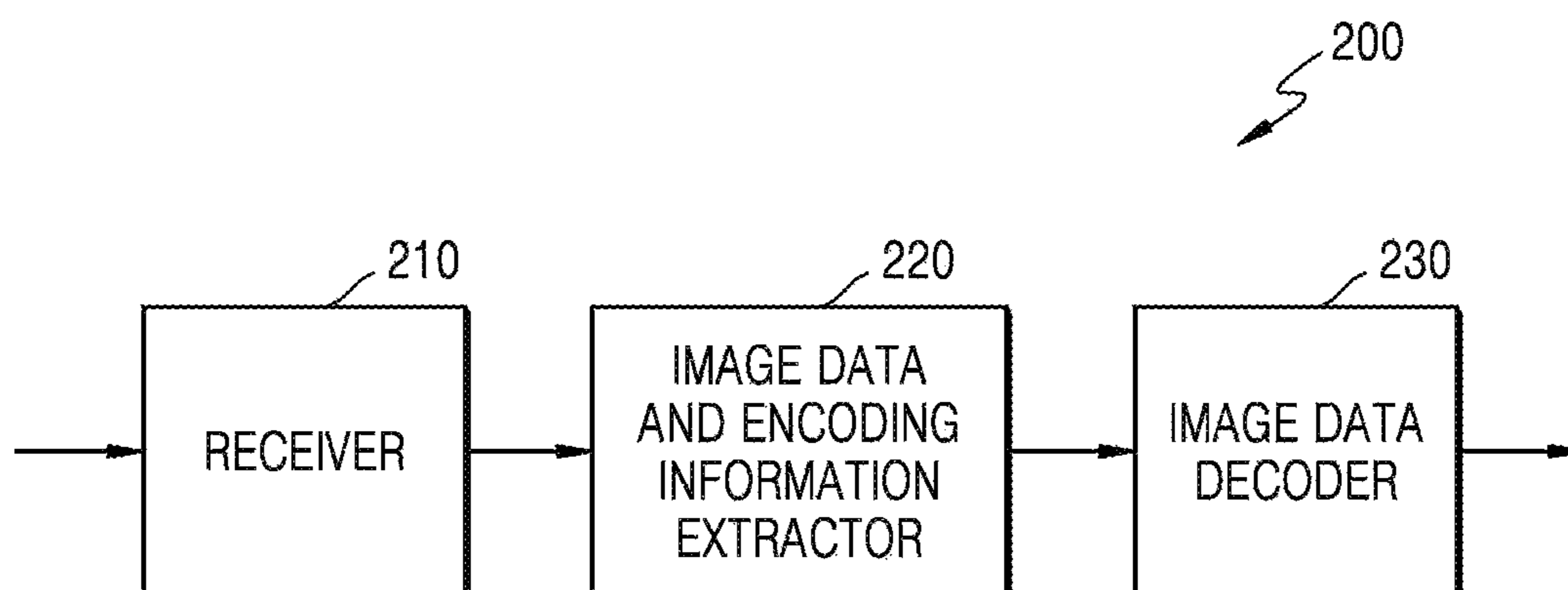

FIG. 9

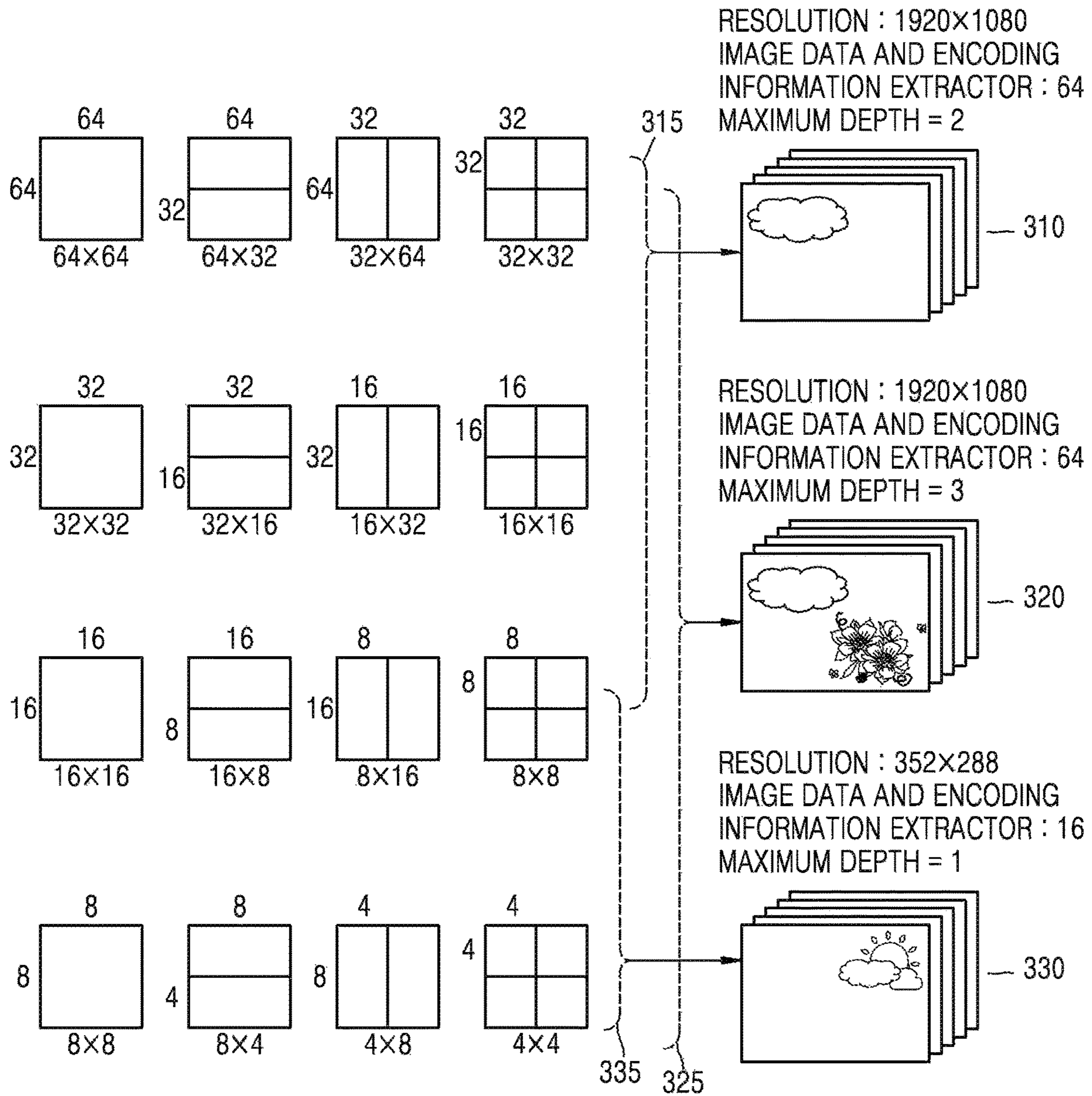

FIG. 10

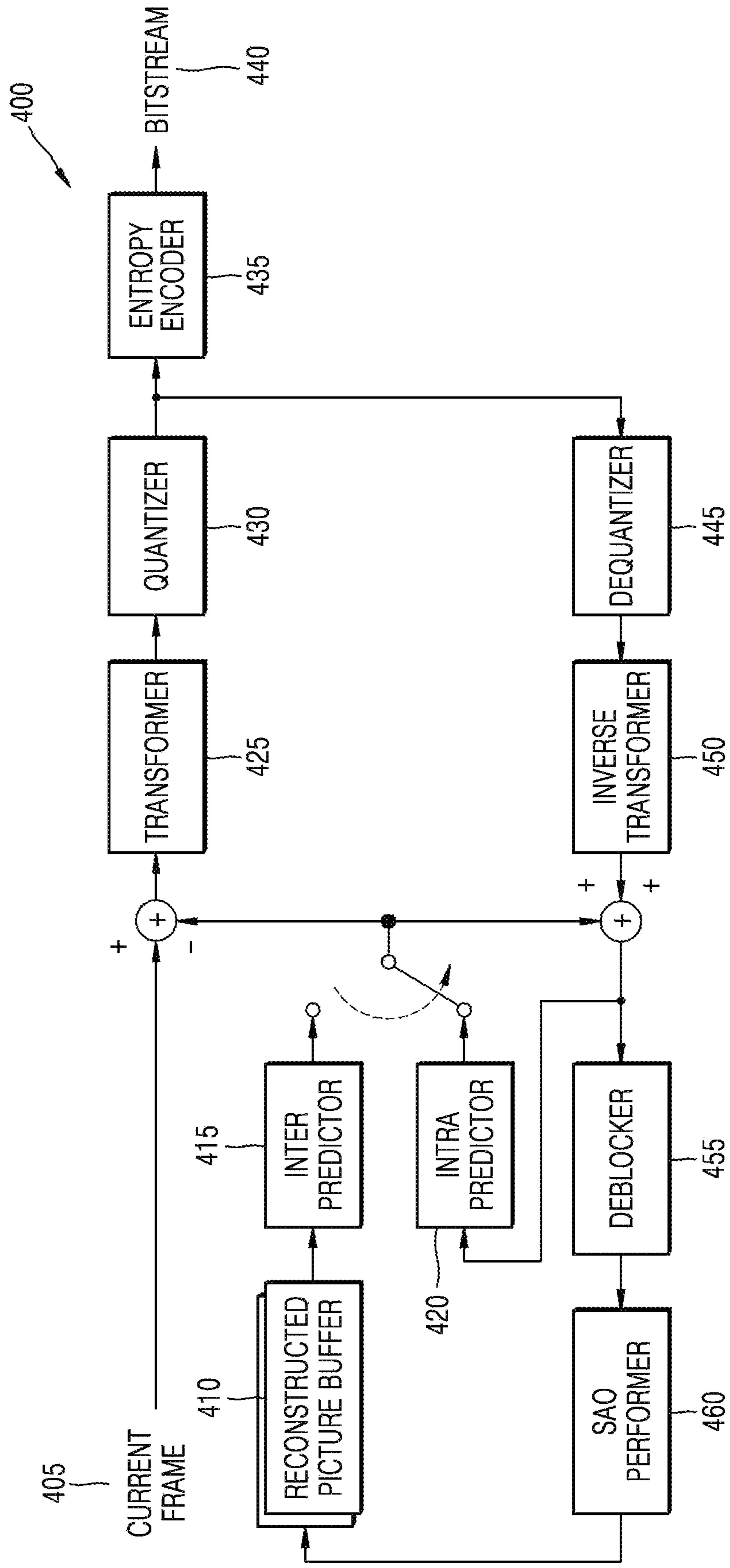

FIG. 11

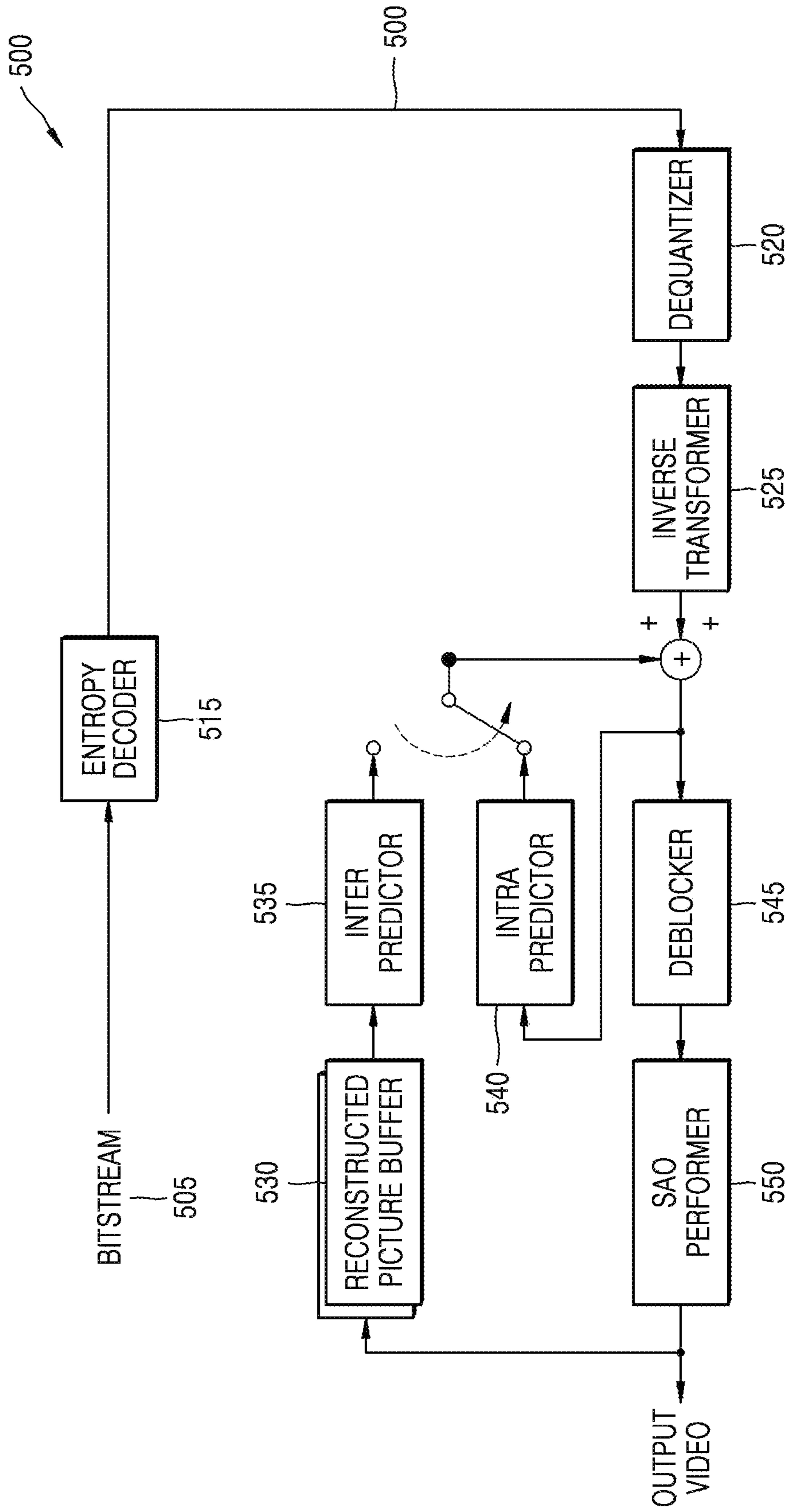

FIG. 12

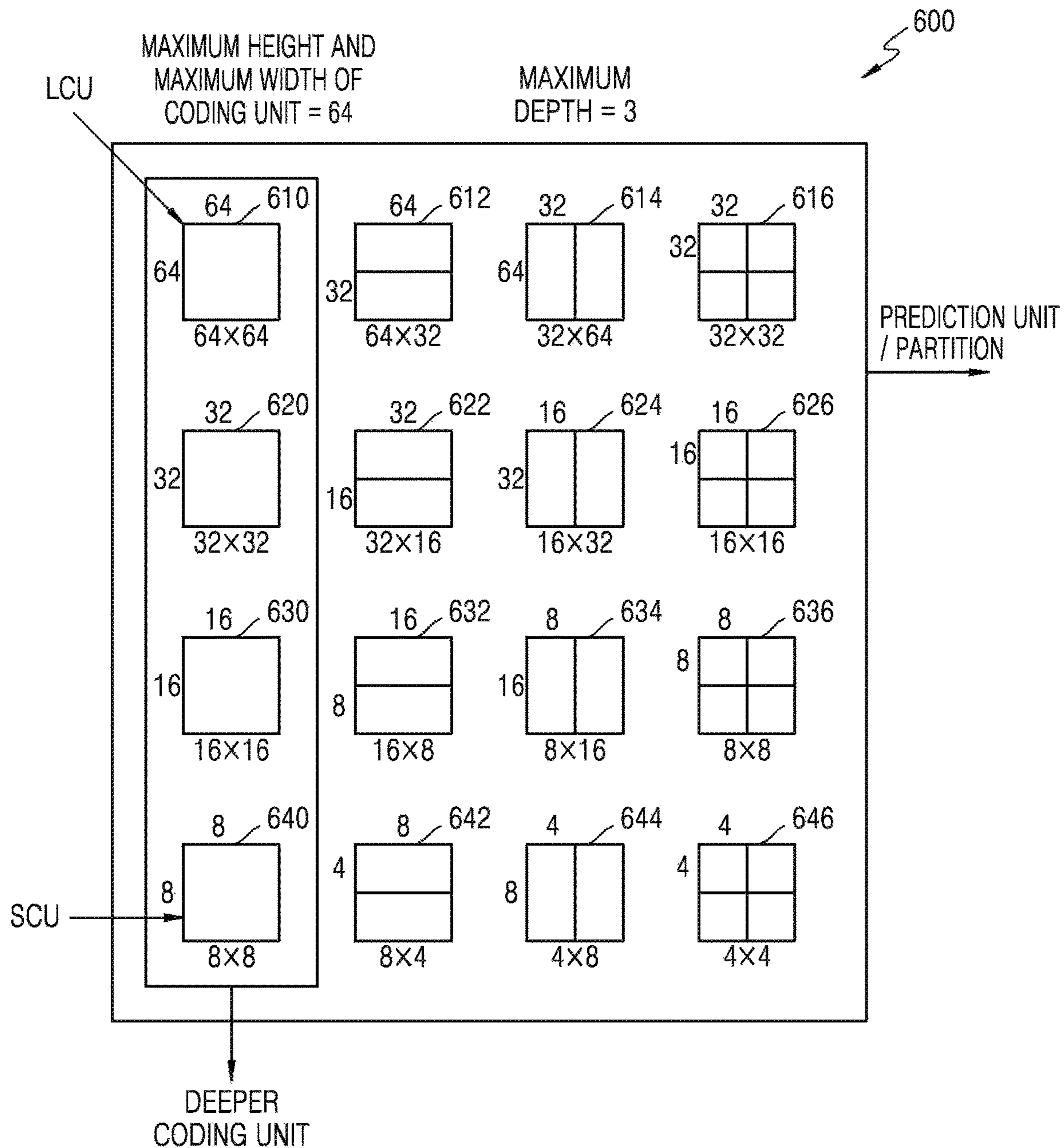

FIG. 13

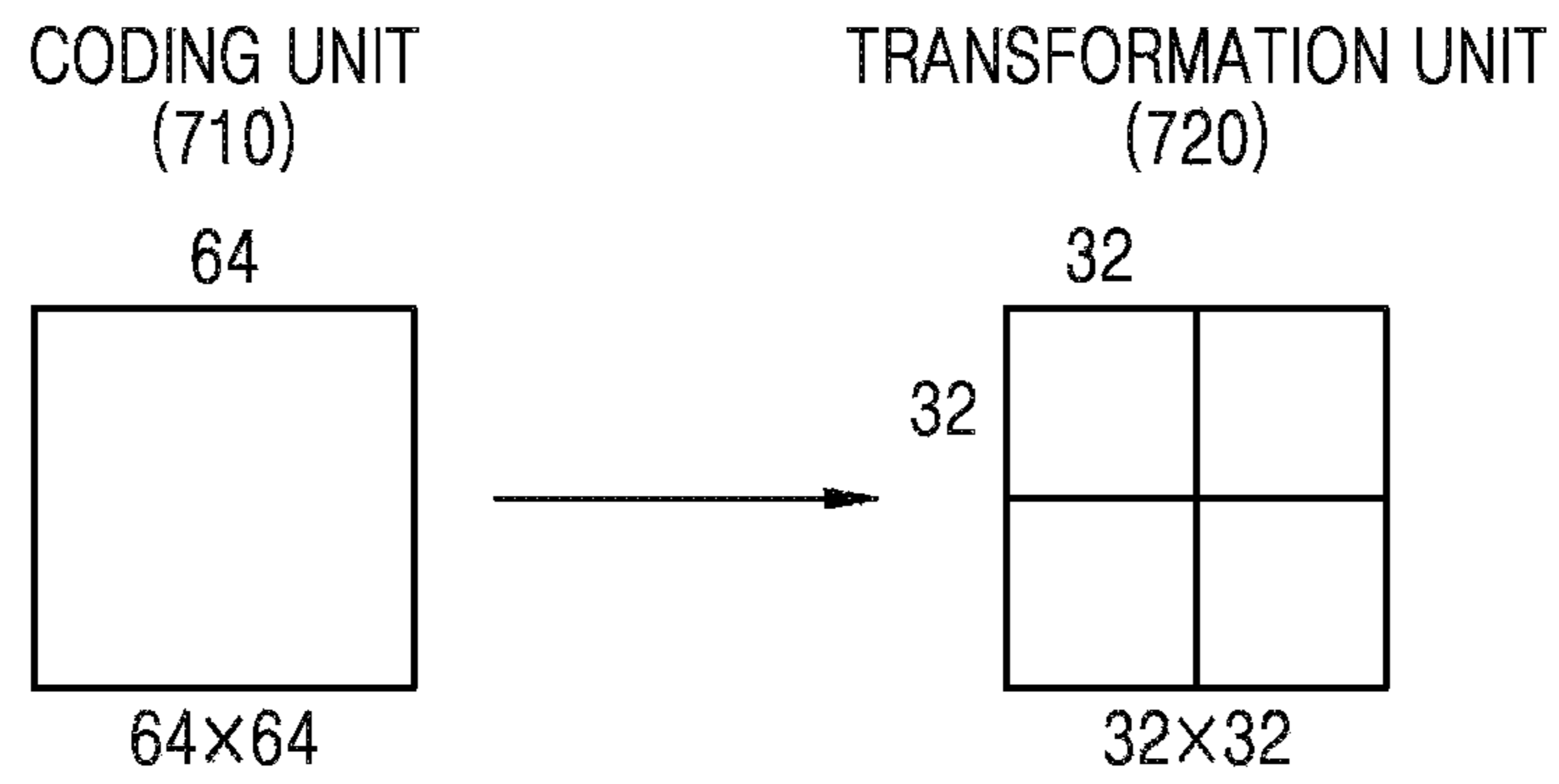

FIG. 14

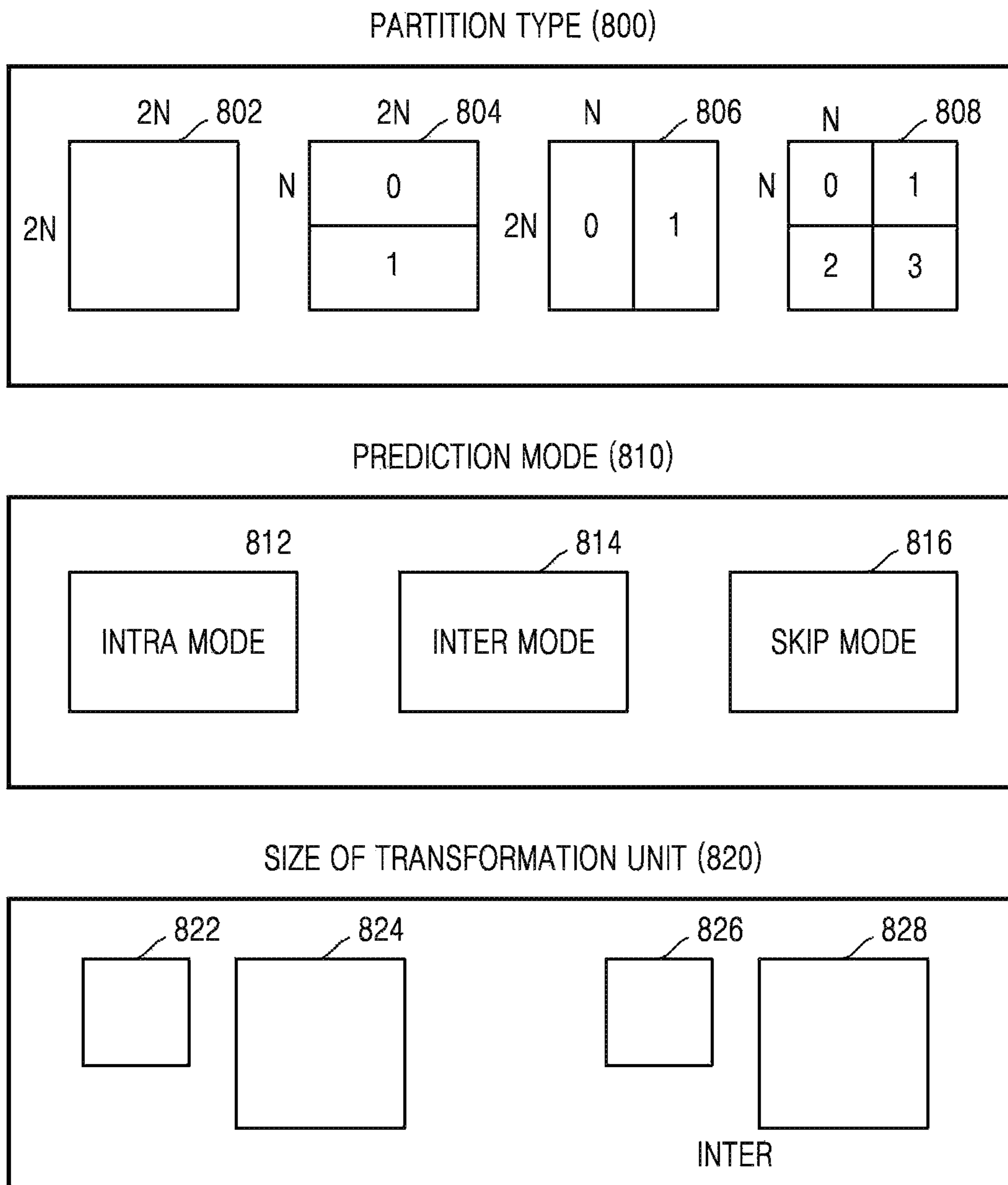

FIG. 15

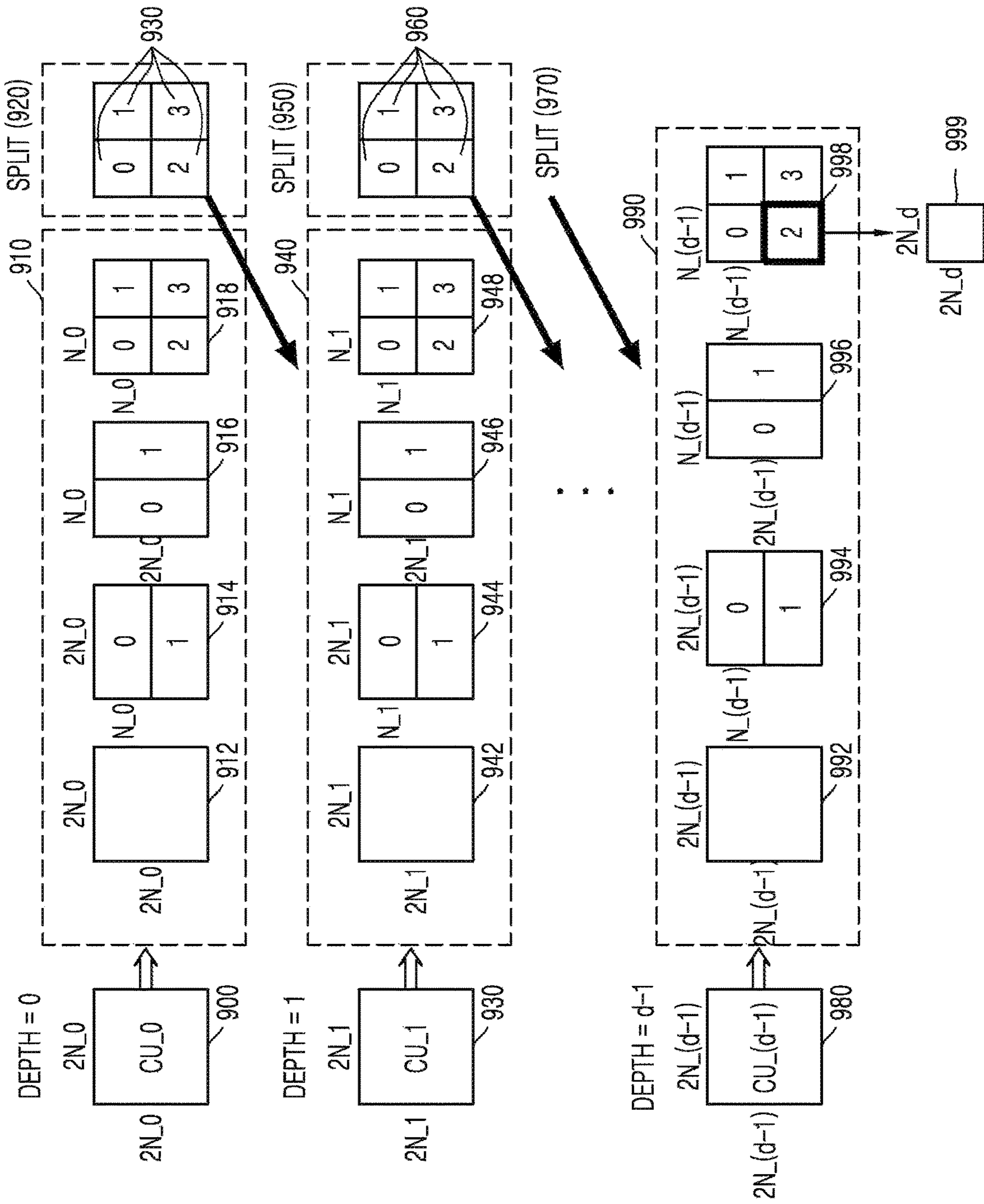
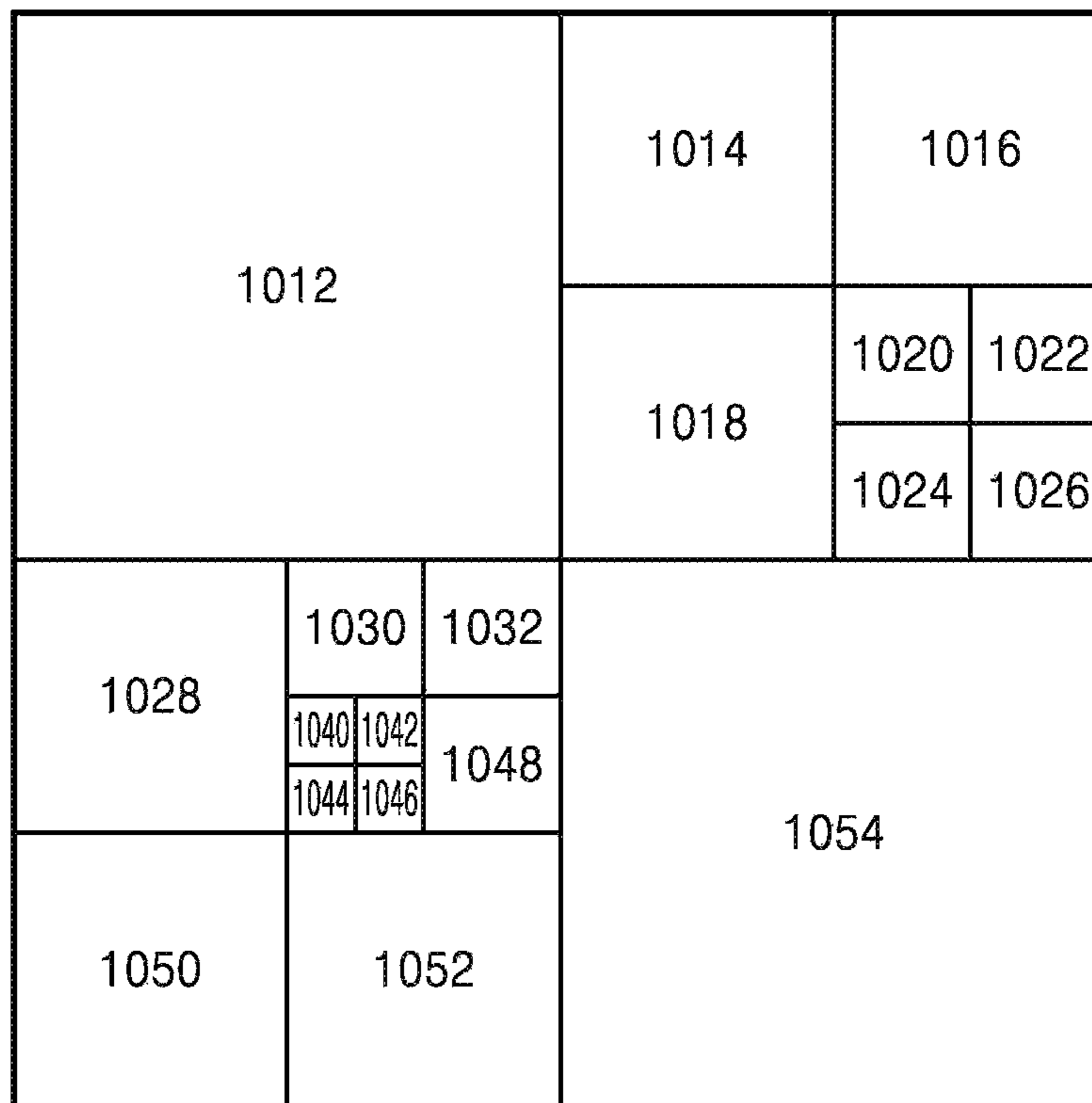

FIG. 16



CODING UNIT (1010)

FIG. 17

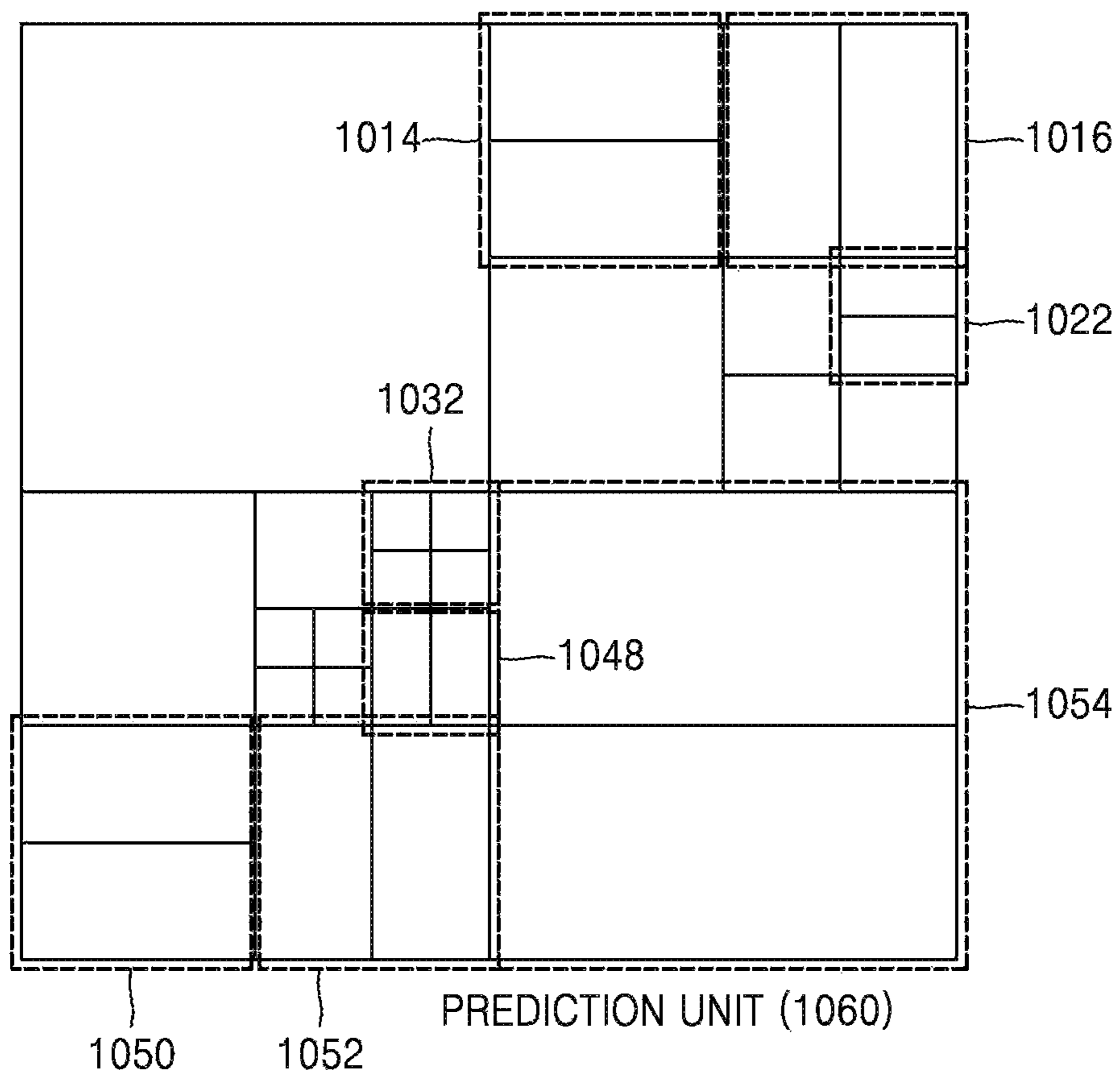

FIG. 18

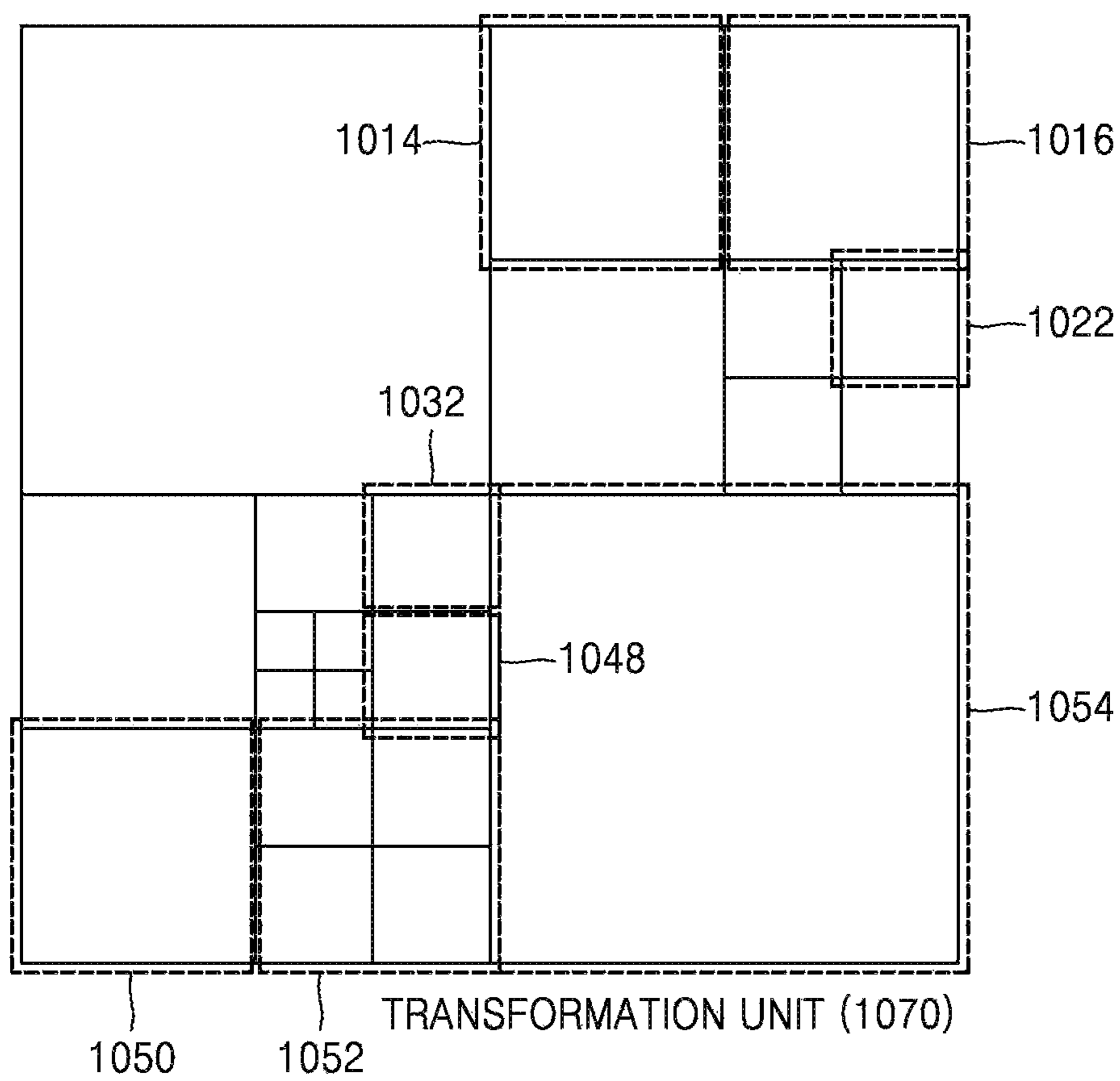

FIG. 19

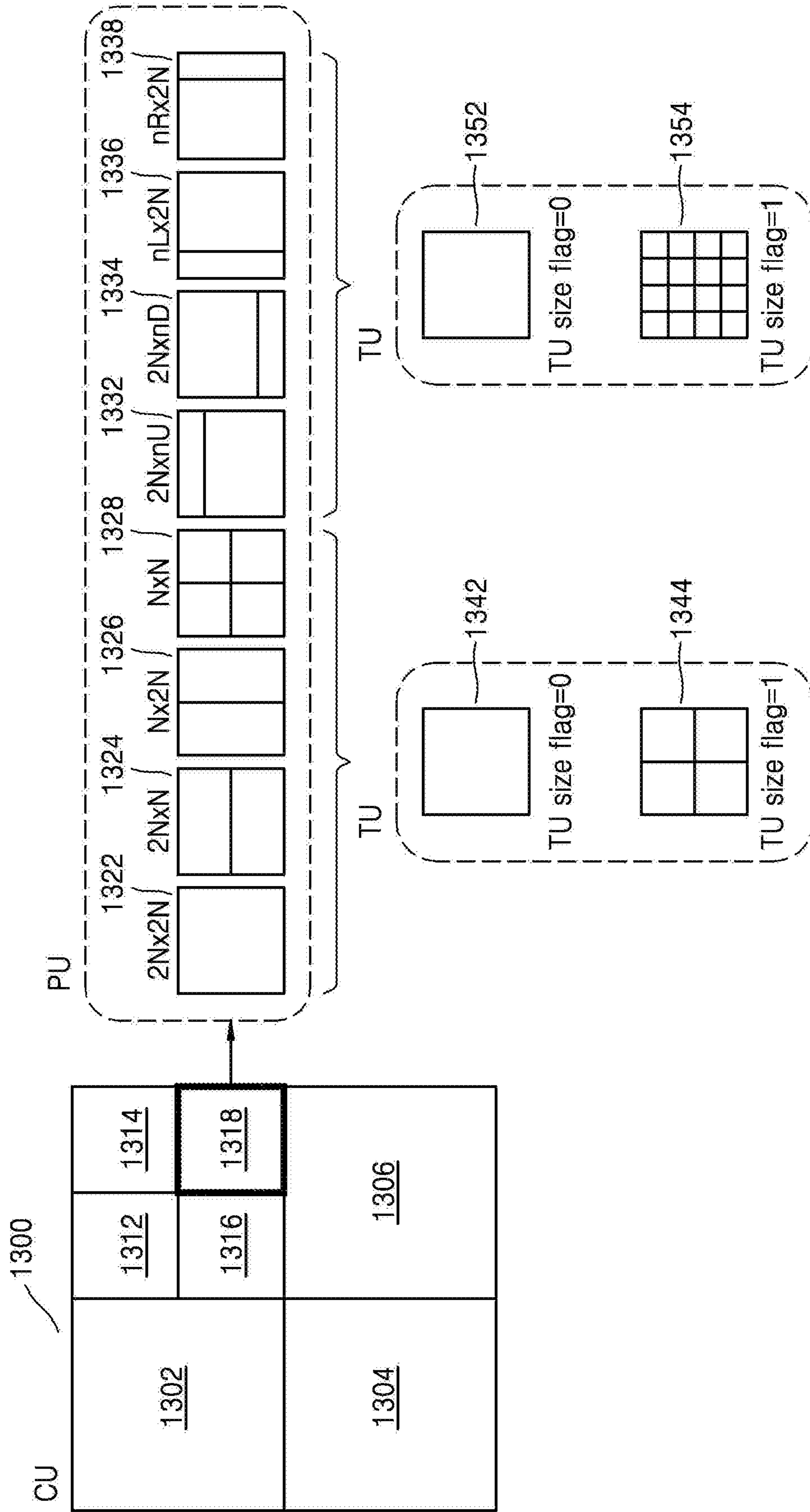

FIG. 20

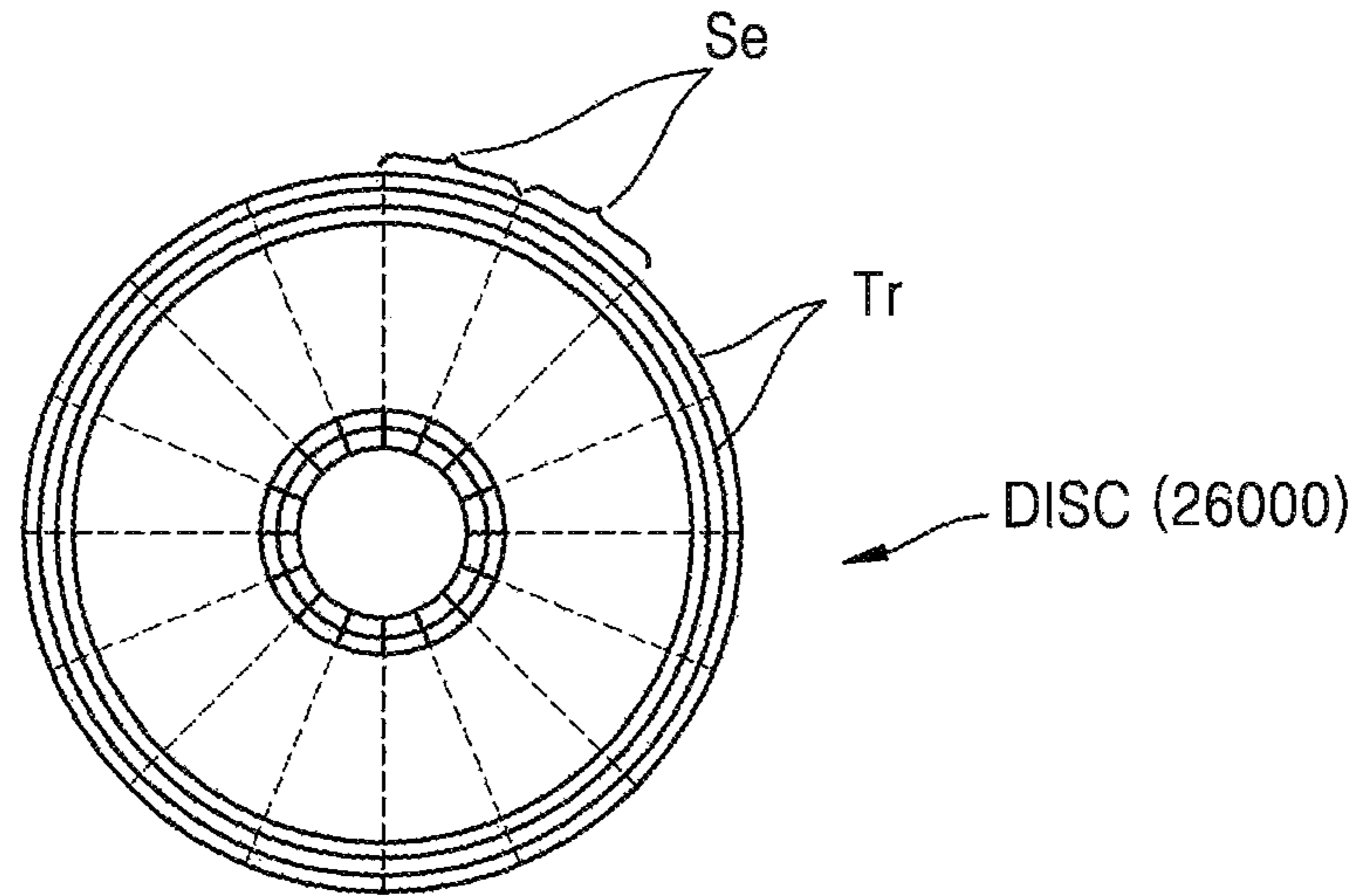

FIG. 21

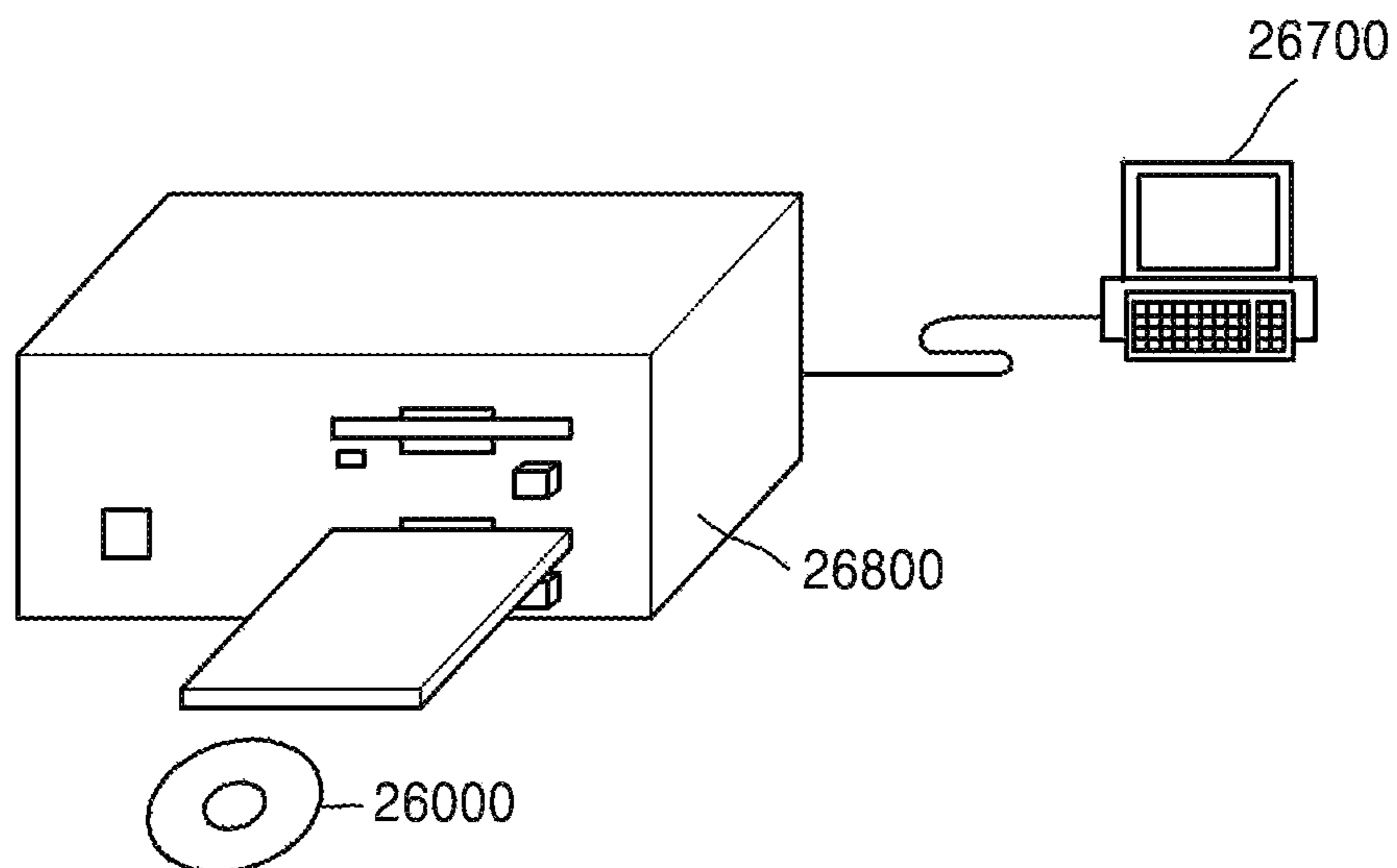

FIG. 22

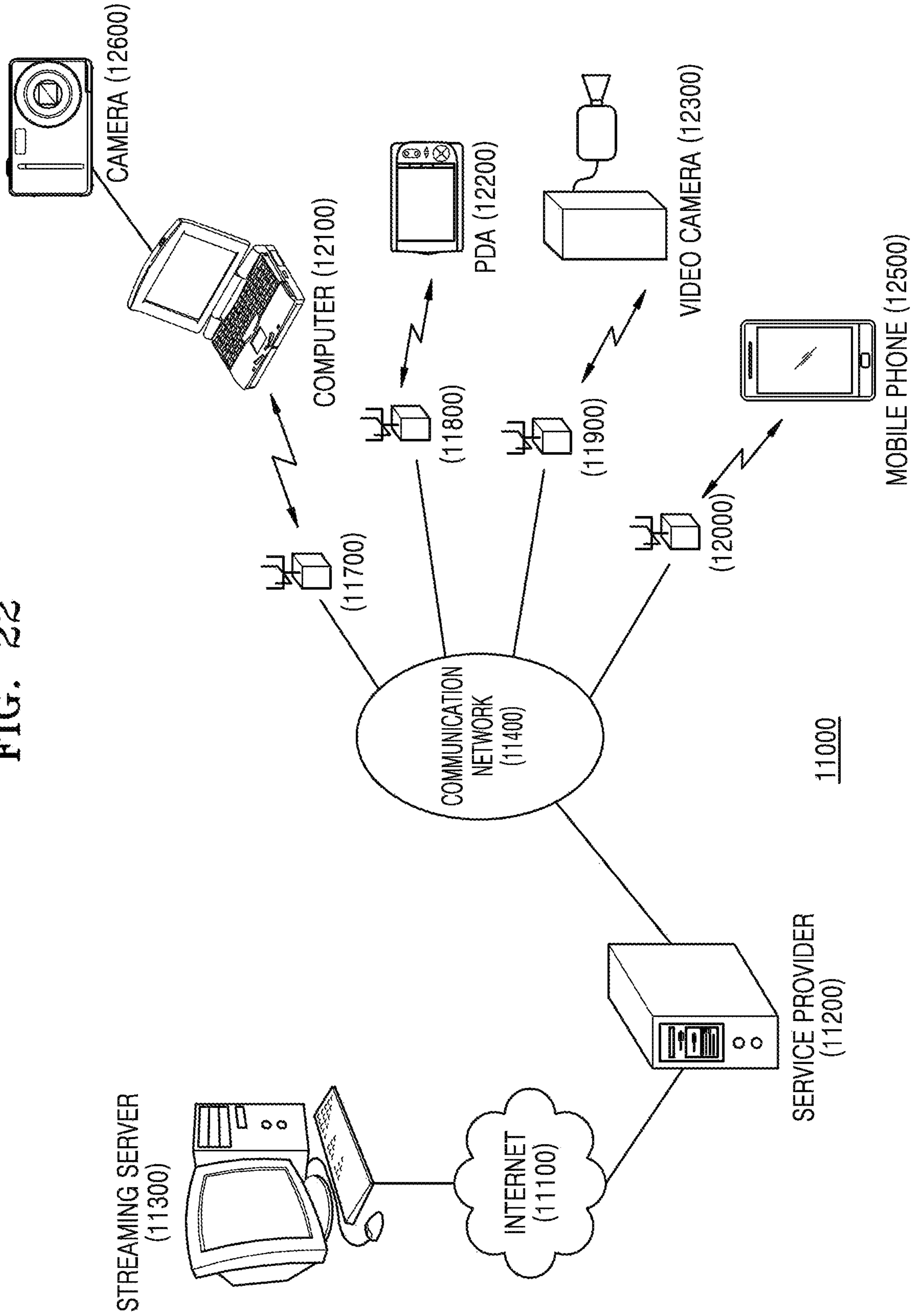

FIG. 23

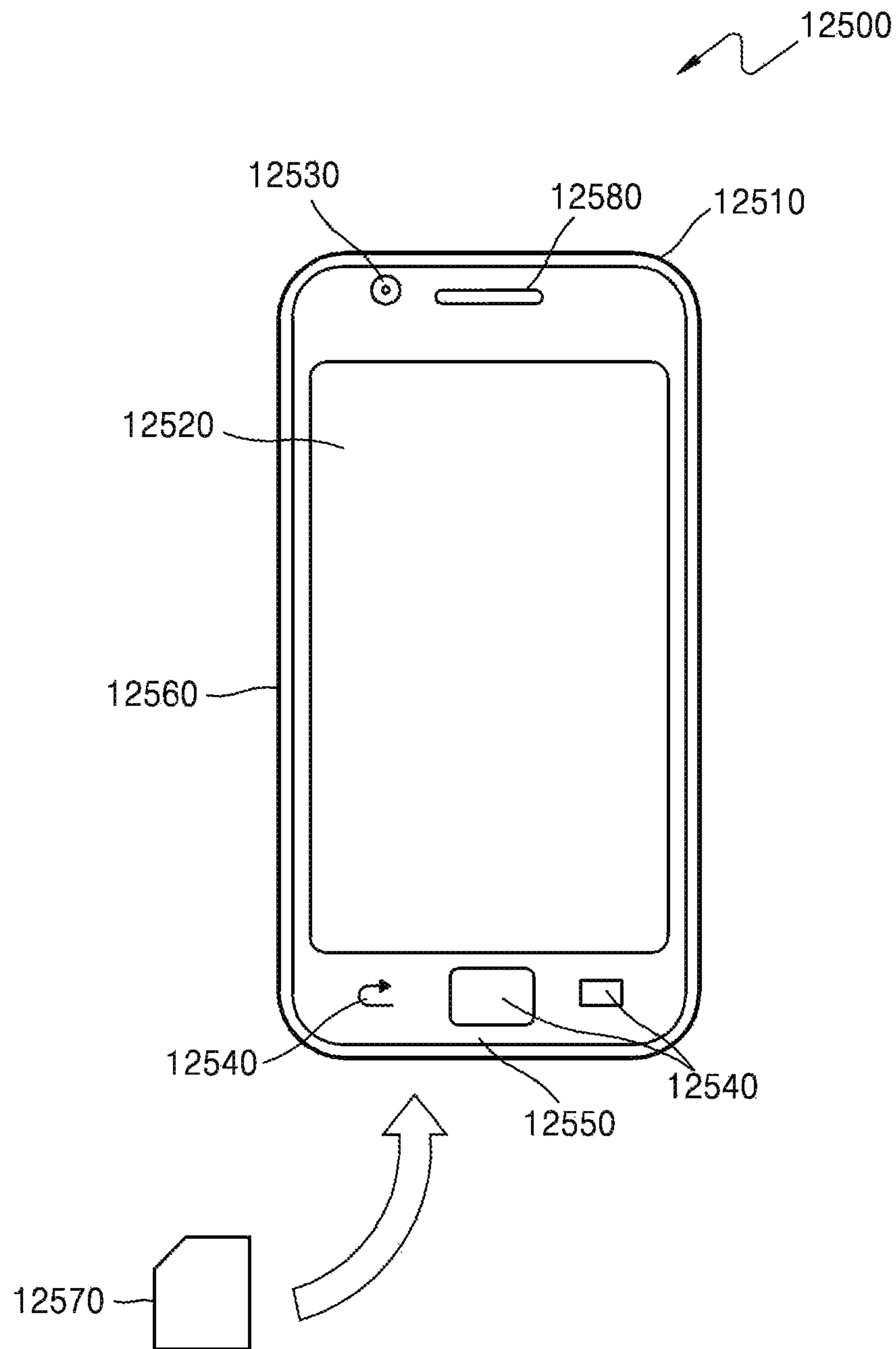

FIG. 24

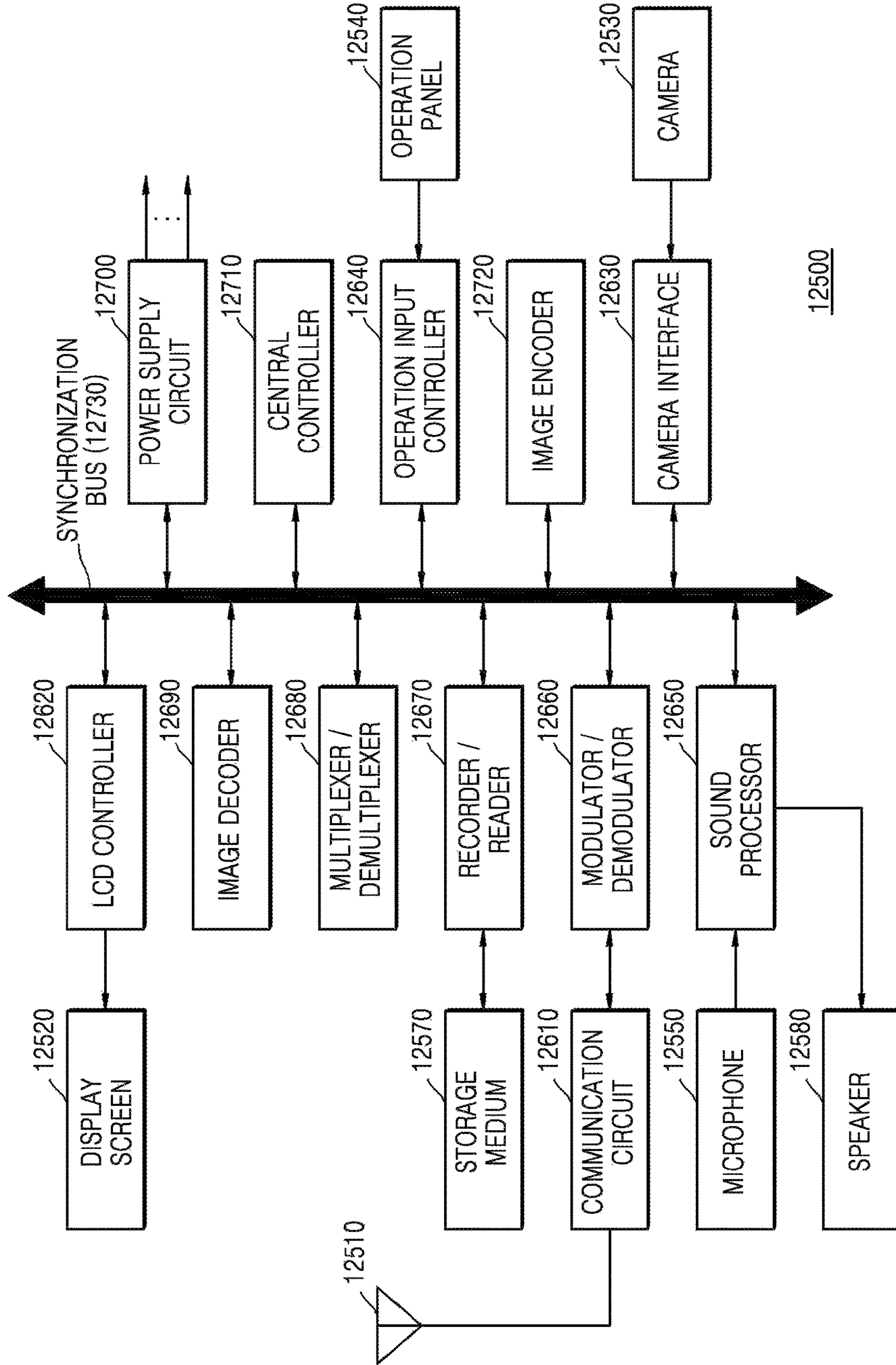

FIG. 25

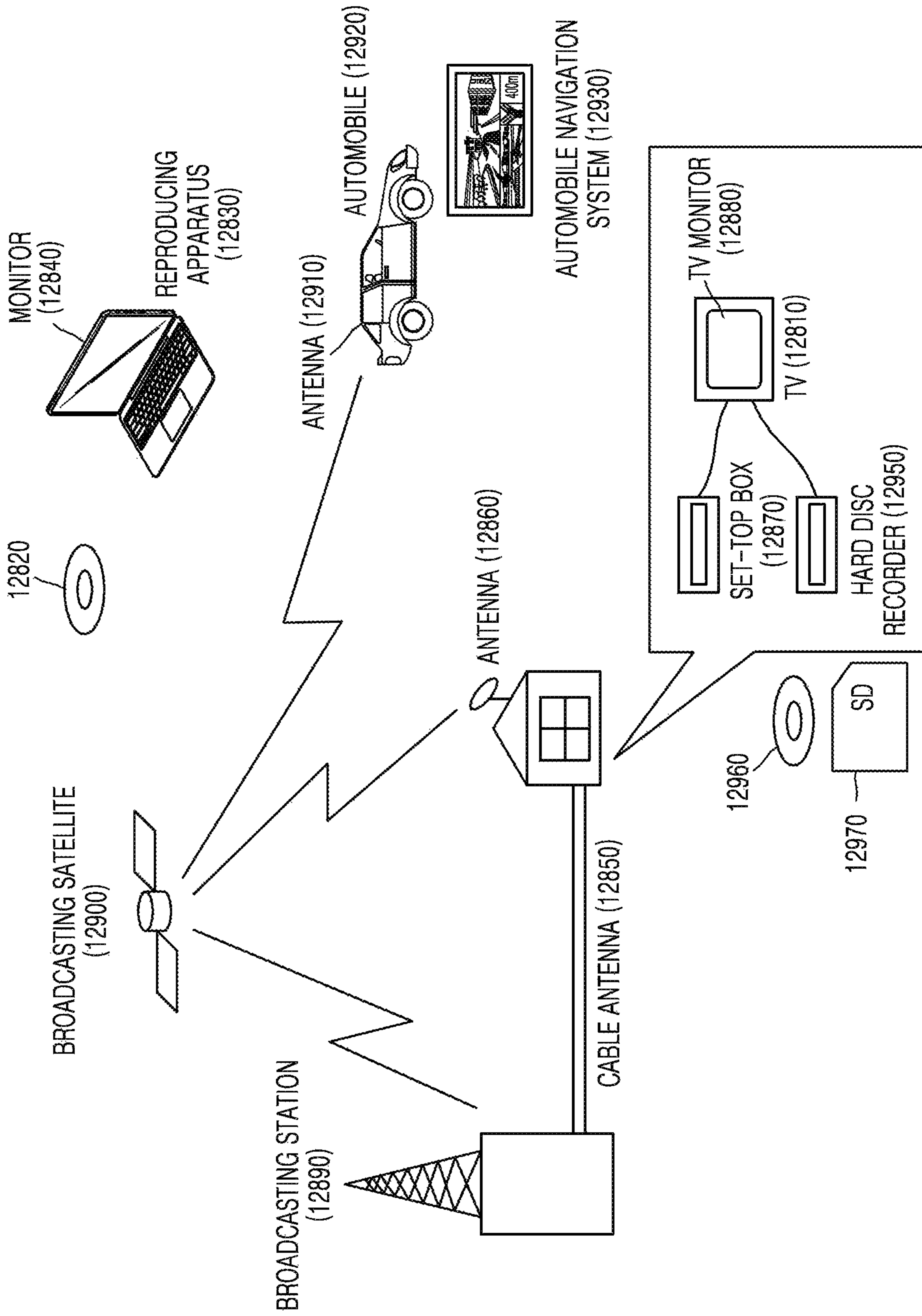
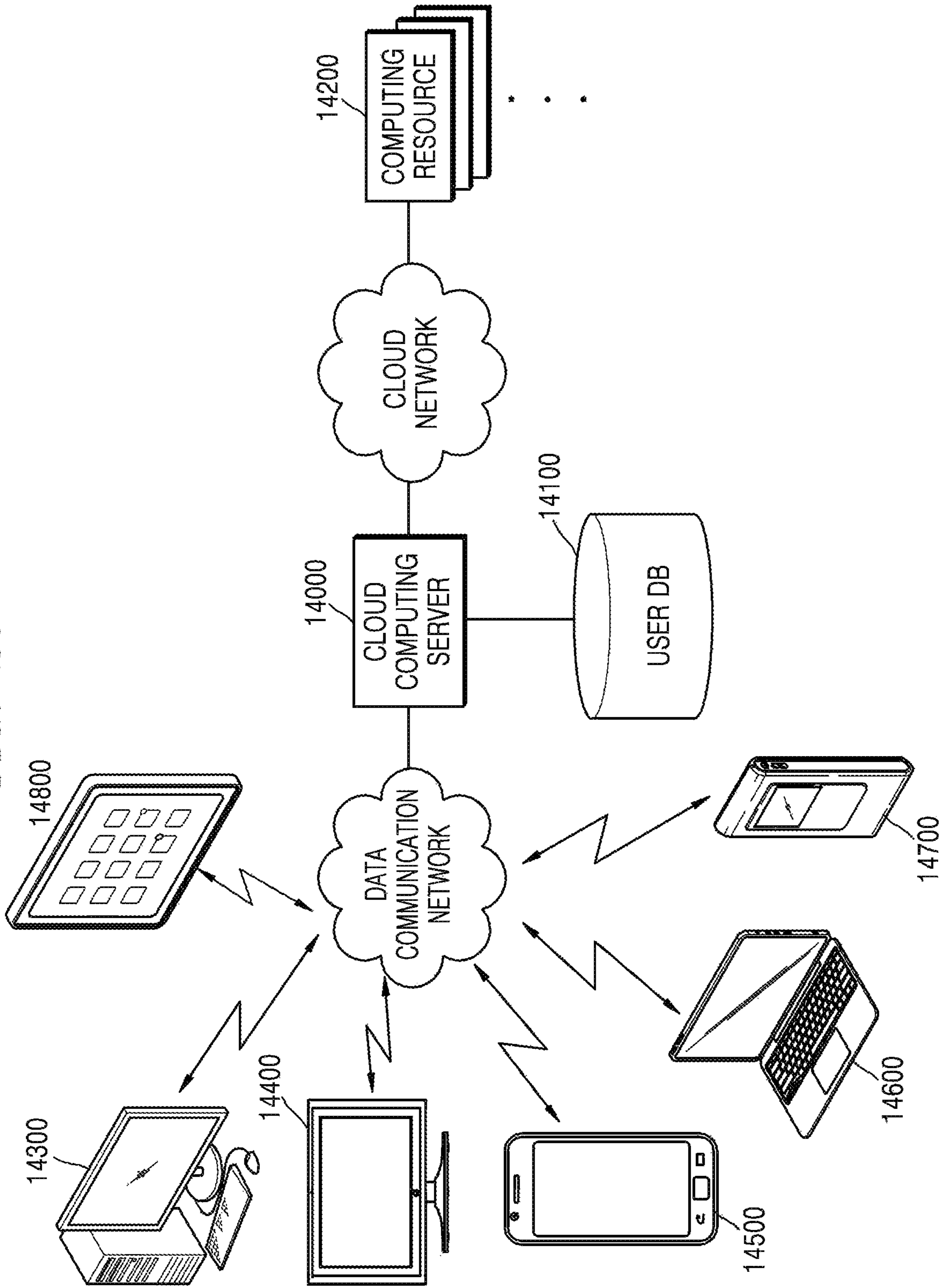

FIG. 26



1**VIDEO ENCODING METHOD AND
APPARATUS THEREFOR, AND VIDEO
DECODING METHOD AND APPARATUS
THEREFOR**

TECHNICAL FIELD

The present disclosure relates to a video encoding method and apparatus therefor, and a video decoding method and apparatus therefor, in which a bit-depth and a sampling rate are considered.

BACKGROUND ART

As hardware for reproducing and storing high resolution or high quality video content is being developed and supplied, a need for a video codec for effectively encoding or decoding the high resolution or high quality video content is increasing. According to a conventional video codec, a video is coded according to a limited coding method based on a coding unit having a predetermined size.

Image data of a spatial region is transformed into coefficients of a frequency region via frequency transformation. According to a video codec, an image is split into blocks having a predetermined size, discrete cosine transformation (DCT) is performed on each block, and frequency coefficients are encoded in block units, for rapid calculation of frequency transformation. Compared with image data of a spatial region, coefficients of a frequency region are easily compressed. In particular, since an image pixel value of a spatial region is expressed according to a prediction error via inter prediction or intra prediction of a video codec, when frequency transformation is performed on the prediction error, a large amount of data may be transformed to 0. According to a video codec, an amount of data may be reduced by replacing data that is consecutively and repeatedly generated with small-sized data.

In particular, when a video decoding apparatus receives and decodes a bitstream including a residue of a bit-depth or a sampling rate which is higher than a bit-depth or a sampling rate which can be processed based on a processing capability of the video decoding apparatus, an image quality significantly deteriorates compared to a case in which the bitstream is decoded by a video decoding apparatus capable of performing a process at the bit-depth or the sampling rate of the residue included in the bitstream.

DETAILED DESCRIPTION OF THE
INVENTION

Technical Solution

According to an aspect of the present disclosure, there is provided a video decoding method including obtaining a residue of a first bit-depth regarding a current block by decoding a bitstream; when the current block is intra predicted, generating a prediction block of the current block by using a block that is previously decoded at the first bit-depth and then is stored in a buffer; and generating a reconstruction block of the first bit-depth by using the prediction block and the residue of the first bit-depth.

According to another aspect of the present disclosure, there is provided a video decoding method including obtaining a residue of a first sampling rate with regarding a current block by decoding a bitstream; when the current block is intra predicted, generating a prediction block of the current block by using a block that is previously decoded at the first

2

sampling rate and then is stored in a buffer; and generating a reconstruction block of the first sampling rate by using the prediction block and the residue of the first sampling rate.

Advantageous Effects of the Invention

Deterioration in an image quality can be minimized by encoding and decoding a video in consideration of a bit-depth and a sampling rate.

DESCRIPTION OF THE DRAWINGS

FIG. 1A is a block diagram of a video encoding apparatus, according to an embodiment.

FIG. 1B is a flowchart of a video encoding method, according to an embodiment.

FIG. 1C is a block diagram of a video decoding apparatus, according to an embodiment.

FIG. 1D is a flowchart of a video decoding method, according to an embodiment.

FIG. 2A is a block diagram of a video encoding apparatus, according to another embodiment.

FIG. 2B is a flowchart of a video encoding method, according to another embodiment.

FIG. 2C is a block diagram of a video decoding apparatus, according to an embodiment.

FIG. 2D is a flowchart of a video decoding method, according to an embodiment.

FIG. 3 is a block diagram for describing an operation of a video decoding apparatus that decodes a high bit-depth bitstream, according to an embodiment.

FIG. 4 is a block diagram for describing an operation of a video decoding apparatus that decodes a high bit-depth bitstream, according to another embodiment.

FIG. 5 is a block diagram for describing an operation of a video decoding apparatus that decodes a high sampling rate bitstream, according to another embodiment.

FIGS. 6A through 6E are diagrams for describing a process in which a video decoding apparatus decodes a high sampling rate bitstream while varying an intra prediction scheme according to a type of a pixel to be currently predicted, according to another embodiment.

FIG. 7 illustrates a block diagram of a video encoding apparatus based on coding units of a tree structure, according to various embodiments.

FIG. 8 illustrates a block diagram of a video decoding apparatus based on coding units of a tree structure, according to various embodiments.

FIG. 9 illustrates a concept of coding units, according to various embodiments.

FIG. 10 is a block diagram of an image encoder based on coding units, according to various embodiments.

FIG. 11 is a block diagram of an image decoder based on coding units, according to various embodiments.

FIG. 12 illustrates deeper coding units according to depths, and partitions, according to various embodiments.

FIG. 13 illustrates a relationship between a coding unit and transformation units, according to various embodiments.

FIG. 14 illustrates a plurality of pieces of encoding information according to depths, according to various embodiments.

FIG. 15 illustrates deeper coding units according to depths, according to various embodiments.

FIGS. 16, 17, and 18 illustrate a relationship between coding units, prediction units, and transformation units, according to various embodiments.

FIG. 19 illustrates a relationship between a coding unit, a prediction unit, and a transformation unit, according to encoding mode information of Table 1.

FIG. 20 illustrates a physical structure of a disc in which a program is stored, according to various embodiments.

FIG. 21 illustrates a disc drive for recording and reading a program by using the disc.

FIG. 22 illustrates an overall structure of a content supply system for providing a content distribution service.

FIGS. 23 and 24 illustrate external and internal structures of a mobile phone to which a video encoding method and a video decoding method are applied, according to various embodiments.

FIG. 25 illustrates a digital broadcasting system employing a communication system.

FIG. 26 illustrates a network structure of a cloud computing system using the video encoding apparatus and the video decoding apparatus, according to various embodiments.

BEST MODE

According to an aspect of the present disclosure, there is provided a video decoding method including obtaining a residue of a first bit-depth regarding a current block by decoding a bitstream; when the current block is intra predicted, generating a prediction block of the current block by using a block that is previously decoded at the first bit-depth and then is stored in a buffer; and generating a reconstruction block of the first bit-depth by using the prediction block and the residue of the first bit-depth.

When the current block is inter predicted, a prediction block of a second bit-depth may be generated by using an image previously decoded at the second bit-depth, the prediction block of the current block may be generated by changing the generated prediction block of the second bit-depth to the first bit-depth, and the first bit-depth may be higher than the second bit-depth.

The video decoding method may further include storing the reconstruction block of the first bit-depth in the buffer.

When a block, to be decoded after the current block, is intra predicted, the video decoding method may further include generating a prediction block of the block to be decoded after the current block by using the reconstruction block of the first bit-depth.

The first bit-depth may indicate 10 bits, and the second bit-depth may indicate 8 bits.

The obtaining of the residue of the first bit-depth with respect to the current block by decoding the bitstream may include generating a transform coefficient of the first bit-depth by inverse-quantizing the bitstream; and obtaining the residue of the first bit-depth by inverse-transforming the generated transform coefficient of the first bit-depth.

The reconstruction block may be clipped in a clipping range corresponding to a range of values that can be expressed with respect to the first bit-depth.

According to another aspect of the present disclosure, there is provided a video decoding method including obtaining a residue of a first sampling rate regarding a current block by decoding a bitstream; when the current block is intra predicted, generating a prediction block of the current block by using a block that is previously decoded at the first sampling rate and then stored in a buffer; and generating a reconstruction block of the first sampling rate by using the prediction block and the residue of the first sampling rate.

When the current block is inter predicted, a prediction block of a second sampling rate may be generated by using

an image previously decoded at the second sampling rate, the prediction block of the current block may be generated by changing the generated prediction block of the second sampling rate to the first sampling rate, and the first sampling rate may be higher than the second sampling rate.

The video decoding method may further include storing the reconstruction block of the first sampling rate in the buffer.

When a block to be decoded after the current block is intra predicted, the video decoding method may further include generating a prediction block of the block to be decoded after the current block by using the reconstruction block of the first sampling rate.

In the generating, when the current block is intra predicted, of the prediction block of the current block by using the block that is previously decoded at the first sampling rate and then is stored in the buffer, a reference pixel, which is from among pixels included in the current block and is to be used in intra predicting a block to be decoded after the current block, may be predicted by using the block that is previously decoded at the first sampling rate and then is stored in the buffer, other pixels excluding the reference pixel which are included in the current block may be predicted by using a block of the second sampling rate which is previously decoded and then is stored in the buffer, and the block of the second sampling rate may be generated by changing the block that is previously decoded at the first sampling rate to the second sampling rate.

According to another aspect of the present disclosure, there is provided a video decoding apparatus including a buffer configured to store a block to be used in intra prediction; and a decoder configured to obtain a residue of a first bit-depth regarding a current block by decoding a bitstream, when the current block is intra predicted, to generate a prediction block of the current block by using the block that is previously decoded at the first bit-depth and then is stored in the buffer, and to generate a reconstruction block of the first bit-depth by using the prediction block and the residue of the first bit-depth.

When the current block is inter predicted, a prediction block of a second bit-depth may be generated by using an image previously decoded at the second bit-depth, the prediction block of the current block may be generated by changing the generated prediction block of the second bit-depth to the first bit-depth, and the first bit-depth may be higher than the second bit-depth.

According to another aspect of the present disclosure, there is provided a video decoding apparatus including a buffer configured to store a block to be used in intra prediction; and a decoder configured to obtain a residue of a first sampling rate regarding a current block by decoding a bitstream, when the current block is intra predicted, to generate a prediction block of the current block by using the block that is previously decoded at the first sampling rate and then is stored in the buffer, to generate a reconstruction block of the first sampling rate by using the prediction block and the residue of the first sampling rate.

When the current block is inter predicted, a prediction block of a second sampling rate may be generated by using an image previously decoded at the second sampling rate, the prediction block of the current block is generated by changing the generated prediction block of the second sampling rate to the first sampling rate, and the first sampling rate may be higher than the second sampling rate.

According to another aspect of the present disclosure, there is provided a video encoding method including, when a current block is intra predicted, generating a prediction

5

block of the current block by using a block that is previously decoded at a first bit-depth and then is stored in a buffer; and determining a residue of the first bit-depth by using the generated prediction block, and generating a bitstream including the determined residue of the first bit-depth.

When the current block is inter predicted, a prediction block of a second bit-depth may be generated by using an image previously decoded at the second bit-depth, the prediction block of the current block may be generated by changing the generated prediction block of the second bit-depth to the first bit-depth, the first bit-depth may be higher than the second bit-depth.

According to another aspect of the present disclosure, there is provided a video encoding method including, when a current block is intra predicted, generating a prediction block of the current block by using a block that is previously decoded at a first sampling rate and then is stored in a buffer; and determining a residue of the first sampling rate by using the generated prediction block, and generating a bitstream including the determined residue of the first sampling rate.

When the current block is inter predicted, a prediction block of a second sampling rate may be generated by using an image previously decoded at the second sampling rate, the prediction block of the current block may be generated by changing the generated prediction block of the second sampling rate to the first sampling rate, and the first sampling rate may be higher than the second sampling rate.

According to another aspect of the present disclosure, there is provided a video encoding apparatus including a buffer configured to store a block to be used in intra prediction; and an encoder configured to, when intra predicting a current block, generate a prediction block of the current block by using the block that is previously decoded at a first bit-depth and then is stored in the buffer, to determine a residue of the first bit-depth by using the prediction block, to determine the residue of the first bit-depth, and to generate a bitstream including the determined residue of the first bit-depth.

When the current block is inter predicted, a prediction block of a second bit-depth may be generated by using an image previously decoded at the second bit-depth, the prediction block of the current block may be generated by changing the generated prediction block of the second bit-depth to the first bit-depth, and the first bit-depth may be higher than the second bit-depth.

According to another aspect of the present disclosure, there is provided a video encoding apparatus including a buffer configured to store a block to be used in intra prediction; and an encoder configured to, when intra predicting a current block, generate a prediction block of the current block by using the block that is previously decoded at a first sampling rate and then is stored in the buffer, to determine a residue of the first sampling rate by using the prediction block, and to generate a bitstream including the determined residue of the first sampling rate.

When the current block is inter predicted, a prediction block of a second sampling rate may be generated by using an image previously decoded at the second sampling rate, the prediction block of the current block may be generated by changing the generated prediction block of the second sampling rate to the first sampling rate, and the first sampling rate may be higher than the second sampling rate.

According to another aspect of the present disclosure, there is provided a computer-readable recording medium

6

having recorded thereon a program for executing the video encoding and decoding methods.

MODE OF THE INVENTION

Terms such as “. . . unit”, “. . . module”, or the like described in the present specification indicate a unit for processing at least one function or operation, wherein the unit and the module may be embodied as hardware or software or embodied by combining hardware and software.

In the present specification, “an embodiment” or “embodiment” means unique characteristic, structure, feature, and the like which are described with an embodiment included in one or more embodiments. Thus, the expression “in an embodiment” or “in embodiment” which is included in throughout the present specification does not necessarily indicate the same embodiment.

With reference to FIGS. 1 through 6E, a video encoding method and a video decoding method performed in consideration of a bit-depth or a sampling rate according to various embodiments will now be described.

Furthermore, with reference to FIGS. 7 through 26, a video encoding method and a video decoding method based on coding units of a tree structure according to various embodiments will be provided. Hereinafter, an ‘image’ may indicate a still image of a video or a moving picture, i.e., the video itself.

First, with reference to FIGS. 1 through 6E, a video encoding method and a video decoding method performed in consideration of a bit-depth or a sampling rate will now be provided.

When a video decoding apparatus decodes a residue of a bit-depth (hereinafter, referred to as a high bit-depth) or a sampling rate (hereinafter, referred to as a high sampling rate), wherein the bit-depth is higher than a processible bit-depth and the sampling rate is higher than a processible sampling rate based on a processing capability of the video decoding apparatus, the video decoding apparatus performs a process of changing the residue of the high bit-depth or the high sampling rate to a residue of a bit-depth or a sampling rate which is processible based on the processing capability of the video decoding apparatus, and then performs a process of reconstructing an image by using the residue of the bit-depth or the sampling rate which is processible based on the processing capability of the video decoding apparatus. However, when the video decoding apparatus changes the residue of the high bit-depth or the high sampling rate to the residue of the bit-depth or the sampling rate which is processible based on the processing capability of the video decoding apparatus, a loss of information occurs, and due to the loss of information, a quality of a reconstructed image deteriorates.

Video encoding apparatuses 10 and 30 and video decoding apparatuses 20 and 40 according to various embodiments changelessly use a residue of a high bit-depth or a high sampling rate without changing the residue of the high bit-depth or the high sampling rate in some of encoding and decoding processes, thereby minimizing image-quality deterioration that occurs in reconstruction of an image of a bit-depth or a sampling rate which exceeds processing capabilities of video encoding and decoding apparatuses.

In more detail, the video encoding apparatuses 10 and 30 and the video decoding apparatuses 20 and 40 changelessly use a residue of a high bit-depth or a high sampling rate in a process of performing intra prediction, thereby minimizing image-quality deterioration that occurs in reconstruction of an image of a bit-depth or a sampling rate which exceeds

processing capabilities of video encoding and decoding apparatuses. The video encoding apparatuses **10** and **30** and the video decoding apparatuses **20** and **40** may have buffers to store the residue of the high bit-depth or the high sampling rate, and when the video encoding apparatuses **10** and **30** and the video decoding apparatuses **20** and **40** perform the intra prediction, the video encoding apparatuses **10** and **30** and the video decoding apparatuses **20** and **40** may changelessly use the residue of the high bit-depth or the high sampling rate stored in the buffers, thereby minimizing an image-quality deterioration phenomenon that occurs in reconstruction of the image of the bit-depth or the sampling rate which exceeds processing capabilities of video encoding and decoding apparatuses.

Hereinafter, with reference to FIGS. **1A** and **1B**, and **2A** and **2B**, operations of the video encoding apparatuses **10** and **30** according to various embodiments will now be described in detail, and with reference to FIGS. **1C** and **1D**, and **2C** and **2D**, operations of the video decoding apparatuses **20** and **40** according to various embodiments will now be described in detail.

FIG. **1A** is a block diagram of a video encoding apparatus, according to an embodiment.

Referring to FIG. **1A**, a video encoding apparatus **10** according to an embodiment includes an encoder **11**, a first buffer **18**, and a second buffer **19**.

The video encoding apparatus **10** according to an embodiment receives an input of images such as slices of a video, partitions each of the images into blocks, and encodes each of the blocks. A type of a block may be a square or a rectangle, or may be an arbitrary geometrical shape. The block is not limited to a data unit having a uniform size. The block according to an embodiment may be a largest coding unit (LCU), a coding unit (CU), a prediction unit, a transform unit, or the like from among coding units of a tree structure. Video encoding and decoding methods based on the coding units of the tree structure will be described below with reference to FIGS. **7** through **26**. The encoder **11** may include a predictor **12**, a residue generator/transformer/quantizer **15**, a bitstream generator **16**, and an inverse-quantizer/inverse-transformer/residue synthesizer **17**.

The predictor **12** may generate a prediction block of a current block by using an image that is decoded before a current image. In addition, the predictor **12** may generate the prediction block of the current block by using a block that is included in the current image and is from among blocks decoded before the current block.

In order to minimize an amount of data to be encoded, the predictor **12** may perform prediction on the current block by using by using a reconstruction block that is spatially adjacent to the current block or a reconstruction image that is temporally adjacent thereto.

The predictor **12** may include an intra predictor **13** and an inter predictor **14**.

The intra predictor **13** may generate a prediction block of a current block by using neighboring blocks that are located adjacent to the current block and are from among previously-decoded blocks.

For example, the intra predictor **13** may determine at least one reference pixel to be referenced from among pixels adjacent to the left of the current block and pixels adjacent to the top of the current block, and may generate the prediction block of the current block by using the determined reference pixel.

In more detail, the intra predictor **13** may determine a reference pixel from among neighboring pixels according to reference directions. That is, the intra predictor **13** may

determine, from among various reference directions, an optimal reference direction in which a correlation with respect to the current block is high in consideration of a Rate-Distortion Cost (RD cost), and may accordingly determine the reference pixel from among the neighboring pixels.

When the intra predictor **13** intra predicts the current block, the intra predictor **13** may generate a prediction block of the current block by using a block that is previously decoded at a first bit-depth and then is stored in the first buffer **18**. In this regard, a bit-depth means a number of bits used in expressing a sample value of one pixel. Also, the first bit-depth may mean a bit-depth of a residue included in a bitstream.

For example, the intra predictor **13** may generate the prediction block of the current block by using a block that is previously decoded at a bit-depth of **10** and then is stored in the first buffer **18**. In this regard, a bit-depth of the generated prediction block may be the first bit-depth equal to the bit-depth of the block that is previously decoded and stored in the first buffer **18**.

The inter predictor **14** may generate a prediction block of the current block by using an image that is decoded before a current image. For example, the inter predictor **14** may determine a reference image from among images decoded before the current image, and may determine a reference block of the reference image, the reference block having a high correlation with the current block.

The inter predictor **14** determines the reference block having a high correlation with the current block, thereby determining motion information such as a motion vector, a reference picture index, picture list information, or the like.

In this regard, the picture list information means information indicating a picture list including an image to be used in a reference from among one or more picture lists. The inter predictor **14** may determine the picture list information indicating at least one picture list that is to be used in prediction and is from among a L0 list and a L1 list.

The reference picture index means information indicating a picture that is to be used in a reference and is from among a plurality of pictures in a predetermined picture list. The inter predictor **14** may determine the reference picture index indicating the picture that is to be used in a reference and is from among the plurality of pictures in the predetermined picture list.

The motion vector means a vector indicating displacement between the current block and a block having a high correlation with the current block. The inter predictor **14** may determine the motion vector indicating the reference block that is to be used in inter prediction and is from among blocks included in the reference picture.

The inter predictor **14** may generate the prediction block of the current block by using the reference block included in a previously-decoded image.

In order to reduce a size of the motion information to be transmitted, the inter predictor **14** may use a correlation of motion information with respect to the current block and a neighboring block of the current block.

For example, the inter predictor **14** may compose a list including neighboring blocks for deriving motion information of the current block, and may transmit only information indicating a predetermined neighboring block in the list, thereby reducing the size of the motion information.

When the current block is inter predicted, the inter predictor **14** may generate a prediction block of a second bit-depth by using an image that is previously decoded at the second bit-depth. In this regard, the second bit-depth indicates a bit-depth different from the first bit-depth that is a

bit-depth of a residue to be encoded. The second bit-depth may be the bit-depth lower than the first bit-depth.

The inter predictor **14** may generate the prediction block of the first bit-depth by changing the prediction block of the second bit-depth to the first bit-depth. For example, the inter predictor **14** performs a left shift operation on the prediction block of the second bit-depth. That is, the inter predictor **14** shifts bits to the left by a predetermined bit, the bits expressing a sample value of a pixel included in the prediction block of the second bit-depth, and allocates 0 to an empty space created due to the shift operation. Thus, the inter predictor **14** may change the prediction block of the second bit-depth to the first bit-depth that is higher than the second bit-depth. For example, when the current block is inter predicted, the inter predictor **14** may generate a prediction block of bit-depth of 8 by using an image that is previously decoded at a bit-depth of 8. Afterward, the inter predictor **14** may change the prediction block of the bit-depth of 8 to a prediction block of a bit-depth of 10.

The residue generator/transformer/quantizer **15** determines a residue indicating a difference between an original image and the prediction block of the current block which is generated by the predictor **12**.

The residue generator/transformer/quantizer **15** determines the residue indicating the difference between the original image and the prediction block of the first bit-depth which is generated by the predictor **12**. The determined residue may be a residue of the first bit-depth.

The residue generator/transformer/quantizer **15** transforms the residue of the first bit-depth from a spatial domain to a transform domain such as a Hamadard domain. The residue generator/transformer/quantizer **15** quantizes the transformed residue by using a predetermined quantization parameter.

The bitstream generator **16** generates a bitstream including the residue quantized by the residue generator/transformer/quantizer **15**. For example, the bitstream generator **16** may generate the bitstream including the quantized residue of the first bit-depth.

The bitstream generator **16** may generate the bitstream including the residue along with an encoding parameter and the motion information determined in an image encoding process.

The inverse-quantizer/inverse-transformer/residue synthesizer **17** may inverse-quantize the residue quantized by the residue generator/transformer/quantizer **15**. The inverse-quantizer/inverse-transformer/residue synthesizer **17** may transform the inverse-quantized residue from the transform domain to the spatial domain. The inverse-quantizer/inverse-transformer/residue synthesizer **17** may generate a reconstruction block of the current block by using the transformed residue of the first bit-depth and the prediction block generated by the predictor **12**.

The inverse-quantizer/inverse-transformer/residue synthesizer **17** may generate the reconstruction block of the current block of the first bit-depth by using the prediction block of the first bit-depth and the inverse-transformed residue of the first bit-depth.

For example, the inverse-quantizer/inverse-transformer/residue synthesizer **17** may generate a reconstruction block of a bit-depth of 10 by using a prediction block of a bit-depth of 10 and an inverse-transformed residue of a bit-depth of 10.

Also, the inverse-quantizer/inverse-transformer/residue synthesizer **17** may generate a reconstruction image including reconstruction blocks. For example, the inverse-quantizer/inverse-transformer/residue synthesizer **17** may change

the reconstruction block of the first bit-depth to a reconstruction block of a second bit-depth, and may generate a reconstruction image including the changed reconstruction block of the second bit-depth.

The first buffer **18** may store the reconstruction block of the first bit-depth which is to be used in intra prediction. For example, the first buffer **18** may store neighboring pixels that are adjacent to the current block and are from among pixels reconstructed before the current block.

The second buffer **19** may store the reconstruction image of the second bit-depth which is to be used in inter prediction.

The reconstruction block stored in the first buffer **18** may be used in intra predicting a block to be encoded after the current block. The reconstruction image stored in the second buffer **19** may be used in inter predicting an image to be encoded after the current image. For example, the intra predictor **13** may generate a prediction block of a block to be encoded after the current block, by using the reconstruction block of the first bit-depth stored in the first buffer **18**.

The inter predictor **14** may generate a prediction block of an image to be encoded after the current image by using the reconstruction image of the second bit-depth stored in the second buffer **19**. The video encoding apparatus **10** according to an embodiment may include a central processor (not shown) to generally control the predictor **12**, the residue generator/transformer/quantizer **15**, the bitstream generator **16**, the inverse-quantizer/inverse-transformer/residue synthesizer **17**, the first buffer **18**, and the second buffer **19**. Alternatively, the predictor **12**, the residue generator/transformer/quantizer **15**, the bitstream generator **16**, the inverse-quantizer/inverse-transformer/residue synthesizer **17**, the first buffer **18**, and the second buffer **19** operate due to respective dedicated-processors (not shown), and the processors (not shown) systemically operate with each other so that the entire video encoding apparatus **10** may operate. Alternatively, the predictor **12**, the residue generator/transformer/quantizer **15**, the bitstream generator **16**, the inverse-quantizer/inverse-transformer/residue synthesizer **17**, the first buffer **18**, and the second buffer **19** may be controlled by the control of an external processor (not shown) of the video encoding apparatus **10** according to an embodiment.

The video encoding apparatus **10** according to an embodiment may include one or more data storages (not shown) in which input and output data of the predictor **12**, the residue generator/transformer/quantizer **15**, the bitstream generator **16**, the inverse-quantizer/inverse-transformer/residue synthesizer **17**, the first buffer **18**, and the second buffer **19** are stored. The video encoding apparatus **10** may include a memory controller (not shown) to manage data input and output of the data storages (not shown).

In order to output a video encoding result, the video encoding apparatus **10** according to an embodiment may operate in cooperation with an internal video encoding processor installed therein or an external video encoding processor so as to perform video encoding operations including transformation.

The internal video encoding processor of the video encoding apparatus **10** according to an embodiment may perform, as a separate processor, the video encoding operation. Also, basic video encoding operations may be realized as the video encoding apparatus **10**, a central processing apparatus, or a graphic processing apparatus includes a video encoding processing module.

FIG. 1B is a flowchart of a video encoding method, according to an embodiment.

11

In operation 1, when the video encoding apparatus 10 intra predicts a current block, the video encoding apparatus 10 may generate a prediction block of a current block by using a block that is previously decoded at a first bit-depth and is stored in a buffer. In this regard, a bit-depth of the prediction block may be the first bit-depth.

In operation 3, the video encoding apparatus 10 may determine a residue of the first bit-depth by using the prediction block of the current block. The video encoding apparatus 10 may determine the residue of the first bit-depth which indicates a difference between the prediction block of the first bit-depth and an original image.

In operation 5, the video encoding apparatus 10 may generate a bitstream including the residue of the first bit-depth. When the video encoding apparatus 10 inter predicts the current block, the video encoding apparatus 10 may generate the prediction block of the current block by using an image that is previously decoded at a second bit-depth. In this regard, the second bit-depth indicates a bit-depth different from the first bit-depth. For example, the first bit-depth may be higher than the second bit-depth.

After the video encoding apparatus 10 generates the prediction block of the current block of which bit depth is the second bit-depth by using the image that is previously decoded at the second bit-depth, the video encoding apparatus 10 may generate a prediction block of which bit-depth is the first bit-depth by using the prediction block of the second bit-depth. That is, the video encoding apparatus 10 may change the prediction block of the second bit-depth to the first bit-depth, thereby generating the prediction block of the first bit-depth.

FIG. 1C is a block diagram of a video decoding apparatus, according to an embodiment.

Referring to FIG. 1C, a video decoding apparatus 20 according to an embodiment includes a decoder 21, a first buffer 27, and a second buffer 28. The decoder 21 may include a bitstream obtainer 22, a predictor 23, and a reconstructor 26.

The bitstream obtainer 22 obtains a bitstream including a residue, an encoding parameter, and motion information.

The predictor 23 may generate a prediction block of a current block by using an image that is decoded before a current image. Alternatively, the predictor 23 may generate the prediction block of the current block by using a block that is from among blocks decoded before the current block and is included in the current image.

The predictor 23 may include an intra predictor 24 and an inter predictor 25.

The intra predictor 24 may generate the prediction block of the current block by using neighboring blocks that are located adjacent to the current block and are from among the blocks decoded before the current block. For example, the intra predictor 24 may determine at least one reference pixel to be referenced from among pixels adjacent to the left of the current block and pixels adjacent to the top of the current block, and may generate the prediction block of the current block by using the determined reference pixel. For example, the intra predictor 24 may obtain a reference direction from the bitstream. Afterward, the intra predictor 24 may determine the reference pixel from among the neighboring blocks by using the obtained reference direction, and may generate the prediction block of the current block by using the determined reference pixel.

When the intra predictor 24 intra predicts the current block, the intra predictor 24 may generate a prediction block of the current block by using a block that is previously decoded at a first bit-depth and then is stored in the first

12

buffer 27. For example, the intra predictor 24 may generate the prediction block of the current block by using a block that is previously decoded at a bit-depth of 10 and then is stored in the first buffer 27. In this regard, a bit-depth of the generated prediction block may be the first bit-depth equal to the bit-depth of the block that is previously decoded and stored in the first buffer 27.

The inter predictor 25 may generate a prediction block of a current block by using an image that is decoded before the current image and then is stored in the second buffer 28. For example, the inter predictor 25 may obtain motion information including a motion vector, a reference picture index, and picture list information from the bitstream. The inter predictor 25 may determine, by using the motion information, a picture list from among picture lists including images decoded before the current image, may determine a reference image from among images included in the determined picture list, and may determine a reference block of the reference image which is to be used in predicting the current block. The inter predictor 25 may determine the prediction block of the current block by using the reference block.

The inter predictor 25 determines a list including neighboring blocks for deriving the motion information, and obtains, from the bitstream, information indicating a neighboring block from among the neighboring blocks included in the list.

The inter predictor 25 may determine the neighboring block by using the information indicating the neighboring block from among the neighboring blocks included in the list, and may determine motion information of the current block by using motion information of the determined neighboring block. That is, the inter predictor 25 may determine the motion vector, the reference picture index, and the picture list information of the current block.

When the inter predictor 25 inter predicts the current block, the inter predictor 25 may generate a prediction block of a second bit-depth by using the image that is previously decoded at the second bit-depth and then is stored in the second buffer 28. In this regard, the second bit-depth indicates a bit-depth different from the first bit-depth. For example, the first bit-depth may be higher than the second bit-depth.

The inter predictor 25 may generate the prediction block of the first bit-depth by changing the prediction block of the second bit-depth to the first bit-depth. When the inter predictor 25 changes the prediction block of the second bit-depth to the first bit-depth, the inter predictor 25 performs a left shift operation on the prediction block of the second bit-depth. That is, the inter predictor 25 shifts bits to the left by a predetermined bit, the bits expressing a sample value of a pixel included in the prediction block of the second bit-depth, and allocates 0 to an empty space at the right which is created due to the shift operation, thereby changing the prediction block of the second bit-depth to the first bit-depth that is higher than the second bit-depth.

For example, when the inter predictor 25 inter predicts the current block, the inter predictor 25 may generate a prediction block of a bit-depth of 8 by using an image that is previously decoded at the bit-depth of 8.

The inter predictor 25 may change the prediction block of the bit-depth of 8 to a prediction block of a bit-depth of 10.

The reconstructor 26 may inverse-quantize the residue of the first bit-depth which is obtained from the bitstream obtainer 22. The reconstructor 26 may inverse-transform the inverse-quantized residue from a transform domain to a spatial domain, thereby obtaining the residue of the first bit-depth.

The reconstructor **26** may generate a reconstruction block of the current block by using the prediction block of the current block which is generated by the predictor **23** and the residue of the first bit-depth. In this regard, a bit-depth of the prediction block may be the first bit-depth. In addition, a bit-depth of the reconstruction block may be the first bit-depth.

The reconstructor **26** may generate a reconstruction image including reconstruction blocks. When the reconstructor **26** generates the reconstruction image, the reconstructor **26** may change the reconstruction blocks of the first bit-depth to the second bit-depth, and may generate a reconstruction image of the second bit-depth, the reconstruction image including the reconstruction blocks of the changed second bit-depth.

The first buffer **27** may store the reconstruction block generated by the reconstructor **26**. For example, the first buffer **27** may store the reconstruction block of the first bit-depth.

The second buffer **28** may store the reconstruction image including the reconstruction blocks of the second bit-depth.

The reconstruction block stored in the first buffer **27** may be used in intra predicting a block to be encoded after the current block.

The reconstruction image stored in the second buffer **28** may be used in inter predicting a block included in an image to be encoded after the current image.

For example, the intra predictor **24** may generate a prediction block of a block to be encoded after the current block, by using the reconstruction block of the first bit-depth stored in the first buffer **27**. The inter predictor **25** may generate a prediction block of an image to be encoded after the current block, by using the reconstruction image of the second bit-depth stored in the second buffer **28**.

The video decoding apparatus **20** according to an embodiment may include a central processor (not shown) to generally control the bitstream obtainer **22**, the predictor **23**, the reconstructor **26**, the first buffer **27**, and the second buffer **28**. Alternatively, the bitstream obtainer **22**, the predictor **23**, the reconstructor **26**, the first buffer **27**, and the second buffer **28** operate due to respective dedicated-processors (not shown), and the processors (not shown) systemically operate with each other so that the entire video decoding apparatus **20** may operate. Alternatively, the bitstream obtainer **22**, the predictor **23**, the reconstructor **26**, the first buffer **27**, and the second buffer **28** may be controlled by the control of an external processor (not shown) of the video decoding apparatus **20** according to an embodiment.

The video decoding apparatus **20** according to an embodiment may include one or more data storages (not shown) in which input and output data of the bitstream obtainer **22**, the predictor **23**, the reconstructor **26**, the first buffer **27**, and the second buffer **28** are stored. The video decoding apparatus **20** may include a memory controller (not shown) to manage data input and output of the data storages (not shown).

In order to reconstruct a video through video decoding, the video decoding apparatus **20** according to an embodiment may operate in cooperation with an internal video decoding processor installed therein or an external video decoding processor so as to perform video decoding operations. The internal video decoding processor of the video decoding apparatus **20** according to an embodiment may perform, as a separate processor, basic video decoding operations. Also, the basic video encoding operations may be realized as the video decoding apparatus **20**, a central processing apparatus, or a graphic processing apparatus includes a video decoding processing module.

FIG. 1D is a flowchart of a video decoding method, according to an embodiment.

In operation **2**, the video decoding apparatus **20** obtains a residue of a first bit-depth regarding a current block by decoding a bitstream. The bitstream includes the residue of the first bit-depth.

In operation **4**, when the video decoding apparatus **20** predicts the current block, the video decoding apparatus **20** generates a prediction block of the current block by using a block that is previously decoded at the first bit-depth and then is stored in a buffer. In this regard, the prediction block may be a prediction block of the first bit-depth.

In operation **6**, the video decoding apparatus **20** may generate a reconstruction block of the first bit-depth by using the prediction block and the residue of the first bit-depth.

When the video decoding apparatus **20** inter predicts the current block, the video decoding apparatus **20** may generate the prediction block of the current block by using a block that is previously decoded at a second bit-depth. In this regard, the second bit-depth indicates a bit-depth different from the first bit-depth. For example, the first bit-depth may be higher than the second bit-depth.

In more detail, after the video decoding apparatus **20** generates the prediction block of the current block of which bit depth is the second bit-depth by using an image that is previously decoded at the second bit-depth, the video decoding apparatus **20** may generate a prediction block of which bit-depth is the first bit-depth by using the prediction block of the second bit-depth. That is, the video decoding apparatus **20** may change the prediction block of the second bit-depth to the first bit-depth, thereby generating the prediction block of the first bit-depth.

When the video decoding apparatus **20** according to an embodiment intra predicts the current block, the video decoding apparatus **20** generates the prediction block of the first bit-depth by using a block that is previously decoded at the first bit-depth higher than the second bit-depth that is processible based on a processing capability of the video decoding apparatus **20**. Thus, the video decoding apparatus **20** obtains the bitstream including the residue of the first bit-depth higher than the second bit-depth that is processible based on the processing capability of the video decoding apparatus **20**, so that an image-quality deterioration phenomenon that may occur in reconstruction of an image may be minimized.

A bit-depth that is supported in inter prediction is proportional to power consumption of the video decoding apparatus. When the video decoding apparatus **20** performs inter prediction, the video decoding apparatus **20** generates the prediction block of the second bit-depth by using an image that is previously decoded at the second bit-depth. Because the video decoding apparatus **20** uses the second bit-depth that is lower than the first bit-depth, when the video decoding apparatus **20** performs inter prediction, power consumption may be sharply reduced compared to a case of using the first bit-depth.

FIG. 2A is a block diagram of a video encoding apparatus, according to another embodiment.

Referring to FIG. 2A, a video encoding apparatus **30** according to an embodiment includes an encoder **31**, a first buffer **38**, and a second buffer **39**.

The encoder **31** may include a predictor **32**, a residue generator/transformer/quantizer **35**, a bitstream generator **36**, an inverse-quantizer/inverse-transformer/residue synthesizer **37**, the first buffer **38**, and the second buffer **39**. The predictor **32** may generate a prediction block of a current block by using an image that is decoded before a current

image. Alternatively, the predictor **32** may generate a prediction block of the current image by using a block that is included in the current image and is from among blocks decoded before the current block.

In order to minimize an amount of data to be encoded, the predictor **32** may perform prediction on the current block by using a reconstruction block that is spatially adjacent to the current block or using a reconstruction image that is temporally adjacent to the current block.

The predictor **32** may include an intra predictor **33** and an inter predictor **34**.

The intra predictor **33** may generate the prediction block of the current block by using neighboring blocks that are located adjacent to the current block and are from among previously-decoded blocks. For example, the intra predictor **33** may determine a reference pixel to be referenced from among pixels adjacent to the left of the current block and pixels adjacent to the top of the current block.

For example, the intra predictor **33** may determine the reference pixel from among the neighboring pixels according to reference directions. That is, the intra predictor **33** may determine, from among various reference directions, an optimal reference direction in which a correlation with respect to the current block is high in consideration of a Rate-Distortion Cost (RD cost), and may accordingly determine the reference pixel from among the neighboring pixels.

When the intra predictor **33** intra predicts the current block, the intra predictor **33** may generate the prediction block of the current block by using a block that is previously decoded at a first sampling rate and then is stored in the first buffer **38**. For example, the intra predictor **33** may generate the prediction block of the current block by using the block that is previously decoded at a luma-chroma sampling ratio of 4:2:2 and then is stored in the first buffer **38**. In this regard, a sampling rate of the generated prediction block may be the same sampling rate as the sampling rate of the block that is previously decoded and then is stored in the first buffer **38**.

In order to reduce chroma sample information compared to luma sample information, a chroma component may be sampled at a sampling rate lower than a luma component. A scheme of sampling the chroma component at the sampling rate lower than the luma component so as to reduce the chroma sample information compared to the luma sample information is called chroma sub-sampling. When the chroma sub-sampling is performed, the chroma sub-sampling may be performed based on a luma-chroma sampling ratio.

The luma-chroma sampling ratio indicates a ratio of a sampling rate of the luma component to a sampling rate of the chroma component.

Examples of the luma-chroma sampling ratio are 4:2:2, 4:2:0, and 4:4:4. In this regard, 4:4:4 means that the luma component is sampled at the same sampling rate as the chroma component, and 4:2:2 means that the chroma component is sampled at a half of a sampling rate of the luma component. In this regard, a sampling rate of horizontal chroma is halved. 4:2:0 means that the chroma component is sampled at a quarter of the sampling rate of the luma component. In this regard, each of horizontal chroma sampling rate and vertical chroma sampling rate is halved.

The inter predictor **34** may generate the prediction block of the current block by using the image that is decoded before the current image. For example, the inter predictor **34** may determine a reference image from among images decoded before the current image, and may determine a

reference block of the reference image, the reference block having a high correlation with the current block.

The inter predictor **34** determines the reference block having a high correlation with the current block, thereby determining motion information such as a motion vector, a reference picture index, picture list information, or the like.

In order to reduce a size of the motion information to be transmitted, the inter predictor **34** may use a correlation of motion information with respect to the current block and a neighboring block of the current block.

For example, the inter predictor **34** may compose a list including neighboring blocks for deriving motion information of the current block, and may transmit only information indicating a predetermined neighboring block in the list, thereby reducing the size of the motion information used in the current block.

When the inter predictor **34** inter predicts the current block, the inter predictor **34** may generate a prediction block of a second sampling rate by using an image that is previously decoded at the second sampling rate. In this regard, the second sampling rate indicates a sampling rate different from the first sampling rate. The first sampling rate may be higher than the second sampling rate.

The inter predictor **34** may generate the prediction block of the first sampling rate by changing the prediction block of the second sampling rate to the first sampling rate.

For example when the inter predictor **34** inter predicts the current block, the inter predictor **34** may generate a prediction block of a luma-chroma sampling ratio of 4:2:0 by using an image that is previously decoded at the luma-chroma sampling ratio of 4:2:0. The inter predictor **34** may change the prediction block of the luma-chroma sampling ratio of 4:2:0 to a prediction block of a luma-chroma sampling ratio of 4:2:2.

A process of changing data of a second sampling rate to a first sampling rate is called upsampling. For example, when upsampling is performed in a manner that a ratio of luma-chroma sampling is increased, the inter predictor **34** generates a sample value of a sampling position based on a first sampling rate by using a sample value of a sampling position based on a second sampling rate, thereby generating a sample of the first sampling rate. The sampling position based on the first sampling rate may include the sampling position and a sub-position based on the second sampling rate. For example, the inter predictor **34** may generate the sample value of the sampling position based on the first sampling rate by using a sample average value at the sampling position based on the second sampling rate.

The residue generator/transformer/quantizer **35** determines a residue indicating a difference between an original image and the prediction block of the current block which is generated by the predictor **32**. The residue generator/transformer/quantizer **35** determines the residue indicating the difference between the original image and the prediction block of the first sampling rate. In this regard, the residue may be a residue of the first sampling rate.

The residue generator/transformer/quantizer **35** transforms the residue of the first sampling rate from a spatial domain to a transform domain. The residue generator/transformer/quantizer **35** may quantize the transformed residue of the first sampling rate by using a predetermined quantization parameter. The bitstream generator **36** generates a bitstream including the residue quantized by the generator/transformer/quantizer **35**. For example, the bitstream generator **36** may generate the bitstream including the residue of the first sampling rate.

The bitstream generator **36** may generate the bitstream including the residue along with an encoding parameter and the motion information determined in an image encoding process.

The inverse-quantizer/inverse-transformer/residue synthesizer **37** inverse-quantizes the quantized residue. The inverse-quantizer/inverse-transformer/residue synthesizer **37** may inverse-transform the inverse-quantized residue from the transform domain to the spatial domain. The inverse-quantizer/inverse-transformer/residue synthesizer **37** may generate a reconstruction block by using the inverse-quantized residue and the prediction block generated by the predictor **32**.

For example, the inverse-quantizer/inverse-transformer/residue synthesizer **37** may generate a reconstruction block of a luma-chroma sampling ratio of 4:2:2 by using the prediction block of the luma-chroma sampling ratio of 4:2:2 and the residue of the luma-chroma sampling ratio of 4:2:2.

The inverse-quantizer/inverse-transformer/residue synthesizer **37** may generate a reconstruction image including reconstruction blocks. For example, the inverse-quantizer/inverse-transformer/residue synthesizer **37** may change the reconstruction block of the first sampling rate to the reconstruction block of the second sampling rate, and may generate a reconstruction image of the second sampling rate which includes the reconstruction block of the second sampling rate.

The first buffer **38** may store the reconstruction block of the first sampling rate. The second buffer **39** may store the reconstruction image of the second sampling rate.

The reconstruction block of the current block which is stored in the first buffer **38** may be used in predicting a block to be encoded after the current block. The reconstruction image including the current block which is stored in the second buffer **39** may be used in predicting an image to be encoded after the current image.

For example, the intra predictor **33** may generate a prediction block of the block to be encoded after the current block, by using the reconstruction block of the first sampling rate which is stored in the first buffer **38**. The inter predictor **34** may generate a prediction block of the image to be encoded after the current image, by using the reconstruction image of the second sampling rate which is stored in the second buffer **39**.

The video encoding apparatus **30** according to an embodiment may include a central processor (not shown) to generally control the predictor **32**, the residue generator/transformer/quantizer **35**, the bitstream generator **36**, the inverse-quantizer/inverse-transformer/residue synthesizer **37**, the first buffer **38**, and the second buffer **39**. Alternatively, the predictor **32**, the residue generator/transformer/quantizer **35**, the bitstream generator **36**, the inverse-quantizer/inverse-transformer/residue synthesizer **37**, the first buffer **38**, and the second buffer **39** operate due to respective dedicated-processors (not shown), and the processors (not shown) systemically operate with each other so that the entire video encoding apparatus **30** may operate. Alternatively, the predictor **12**, the residue generator/transformer/quantizer **15**, the bitstream generator **16**, the inverse-quantizer/inverse-transformer/residue synthesizer **17**, the first buffer **18**, and the second buffer **19** may be controlled by the control of an external processor (not shown) of the video encoding apparatus **10** according to an embodiment.

Alternatively, the predictor **32**, the residue generator/transformer/quantizer **35**, the bitstream generator **36**, the inverse-quantizer/inverse-transformer/residue synthesizer **37**, the first buffer **38**, and the second buffer **39** may be

controlled by the control of an external processor (not shown) of the video encoding apparatus **30** according to an embodiment.

The video encoding apparatus **30** according to an embodiment may include one or more data storages (not shown) in which input and output data of the predictor **32**, the residue generator/transformer/quantizer **35**, the bitstream generator **36**, the inverse-quantizer/inverse-transformer/residue synthesizer **37**, the first buffer **38**, and the second buffer **39** are stored. The video encoding apparatus **30** may include a memory controller (not shown) to manage data input and output of the data storages (not shown).

In order to output a video encoding result, the video encoding apparatus **30** according to an embodiment may operate in cooperation with an internal video encoding processor installed therein or an external video encoding processor so as to perform video encoding operations including transformation.

The internal video encoding processor of the video encoding apparatus **30** according to an embodiment may perform, as a separate processor, the video encoding operation. Also, basic video encoding operations may be realized as the video encoding apparatus **30**, a central processing apparatus, or a graphic processing apparatus includes a video encoding processing module.

FIG. 2B is a flowchart of a video encoding method, according to another embodiment.

In operation **2000**, when the video encoding apparatus **30** intra predicts a current block, the video encoding apparatus **30** may generate a prediction block of the current block by using a block that is previously decoded at a first sampling rate and then is stored in a buffer.

In operation **2200**, when the video encoding apparatus **30** intra predicts the current block, the video encoding apparatus **30** determines a residue of the first sampling rate.

In operation **2400**, the video encoding apparatus **30** generate a bitstream including the residue of the first sampling rate.

When the video encoding apparatus **30** inter predicts the current block, the video encoding apparatus **30** may generate a prediction block of the current block by using an image that is previously decoded at a second sampling rate. In this regard, the second sampling rate indicates a sampling rate different from the first sampling rate. For example, the first sampling rate may be higher than the second sampling rate. In more detail, the first sampling rate may be a sampling rate based on a luma-chroma sampling ratio of 4:2:2, and the second sampling rate may be a sampling rate based on a luma-chroma sampling ratio of 4:2:0.

After the video encoding apparatus **30** generates the prediction block of the current block of which sampling rate is the second sampling rate by using the image that is previously decoded at the second sampling rate, the video encoding apparatus **30** may generate the prediction block of which sampling rate is the first sampling rate by using the prediction block of the second sampling rate.

That is, the video encoding apparatus **30** may change the prediction block of the second sampling rate to the first sampling rate, thereby generating the prediction block of the first sampling rate.

FIG. 2C is a block diagram of a video decoding apparatus, according to an embodiment.

A video decoding apparatus **40** according to an embodiment includes a decoder **41**, a first buffer **47**, and a second buffer **48**.

The decoder **41** may include a bitstream obtainer **42**, a predictor **43**, and a reconstructor **46**.

The bitstream obtainer **42** obtains a bitstream including a residue, an encoding parameter, and motion information.

The predictor **43** may generate a prediction block of a current block by using an image that is decoded before a current image. Alternatively, the predictor **43** may generate the prediction block of the current block by using a block that is from among blocks decoded before the current block and is included in the current image.

The predictor **43** may include an intra predictor **44** and an inter predictor **45**.

The intra predictor **44** may generate the prediction block of the current block by using a neighboring block that is located adjacent to the current block and is from among the blocks decoded before the current block. For example, the intra predictor **44** may determine at least one reference pixel to be referenced from among pixels adjacent to the left of the current block and pixels adjacent to the top of the current block, and may generate the prediction block of the current block by using the determined reference pixel.

For example, the intra predictor **44** may obtain a reference direction from the bitstream. Afterward, the intra predictor **44** may determine the reference pixel from among the neighboring blocks by using the obtained reference direction, and may generate the prediction block of the current block by using the determined reference pixel.

When the intra predictor **44** intra predicts the current block, the intra predictor **44** may generate a prediction block of the current block by using a block that is previously decoded at a first sampling rate and then is stored in the first buffer **47**. For example, the intra predictor **44** may generate the prediction block of the current block by using a block that is previously decoded at a luma-chroma sampling ratio of 4:2:2 and then is stored in the first buffer **47**. In this regard, a luma-chroma sampling ratio of the generated prediction block may be the luma-chroma sampling ratio equal to the luma-chroma sampling ratio of the block that is previously decoded and stored in the first buffer **47**.

The inter predictor **45** may generate a prediction block of a current block by using an image that is decoded before the current image. For example, the inter predictor **45** may obtain motion information including a motion vector, a reference picture index, and picture list information from the bitstream.

The inter predictor **45** may determine, by using the motion information, a picture list from among picture lists including images decoded before the current image, may determine a reference image from among images included in the determined picture list, and may determine a reference block of the reference image which is to be used in predicting the current block. The inter predictor **45** may determine the prediction block of the current block by using the reference block.

The inter predictor **45** determines a list including neighboring blocks for deriving the motion information, and obtains, from the bitstream, information indicating a neighboring block from among the neighboring blocks included in the list. The inter predictor **45** may determine the neighboring block by using the information indicating the neighboring block from among the neighboring blocks included in the list, and may determine motion information of the current block by using motion information of the determined neighboring block. That is, the inter predictor **45** may determine the motion vector, the reference picture index, and the picture list information of the current block.

When the inter predictor **45** inter predicts the current block, the inter predictor **45** may generate a prediction block of a second sampling rate by using the image that is

previously decoded at the second sampling rate. The inter predictor **45** may change the prediction block of the second sampling rate to a first sampling rate, thereby generating a prediction block of the first sampling rate. For example, when the inter predictor **45** inter predicts the current block, the inter predictor **45** may generate a prediction block of a luma-chroma sampling ratio of 4:2:0 by using an image that is previously decoded at the luma-chroma sampling ratio of 4:2:0. The inter predictor **45** may change the prediction block of the luma-chroma sampling ratio of 4:2:0, thereby generating a prediction block of a luma-chroma sampling ratio of 4:2:2. When the inter predictor **45** changes the second sampling rate to the first sampling rate, the inter predictor **45** may perform upsampling. For example, when upsampling is performed in a manner that a ratio of luma-chroma sampling is increased, the inter predictor **44** generates a sample value of a sampling position based on the first sampling rate by using a sample value of a sampling position based on the second sampling rate, thereby generating a sample of the first sampling rate. The sampling position based on the first sampling rate may include the sampling position and a sub-position based on the second sampling rate. For example, the inter predictor **44** may generate the sample value of the sampling position based on the first sampling rate by using a sample average value at the sampling position based on the second sampling rate which is adjacent to the sampling position based on the first sampling rate.

The reconstructor **46** may obtain the residue of the first sampling rate from the obtained bitstream. In more detail, the reconstructor **46** may inverse-quantize the bitstream, thereby obtaining the inverse-quantized residue of the first sampling rate, and may inverse-transform the inverse-quantized residue of the first sampling rate from a transform domain to a spatial domain, thereby obtaining the inverse-transformed residue of the first sampling rate.

The reconstructor **46** may generate a reconstruction block of the current block by using the residue of the first sampling rate and the prediction block of the current block which is generated by the predictor **43**.

In this regard, a sampling rate of the prediction block may be the first sampling rate. Also, a sampling rate of the reconstruction block may be the first sampling rate.

The reconstructor **46** may generate a reconstruction image including reconstruction blocks.

For example, when the reconstructor **46** generates the reconstruction image, the reconstructor **46** may change reconstruction blocks of the first sampling rate to reconstruction blocks of the second sampling rate, and may generate the reconstruction image of the second sampling rate, the reconstruction image including the reconstruction blocks that are changed to the second sampling rate.

The first buffer **47** may store the reconstruction block generated by the reconstructor **46**. The second buffer **48** may store the reconstruction image of the second sampling rate. The reconstruction block stored in the first buffer **47** may be used in intra predicting a block to be encoded after the current block.

The reconstruction image stored in the second buffer **48** may be used in inter predicting a block included in an image to be encoded after the current image.

For example, the intra predictor **44** may generate a prediction block of a block to be encoded after the current block, by using the reconstruction block of the first sampling rate stored in the first buffer **47**. The inter predictor **45** may generate a prediction block of an image to be encoded after

the current block, by using the reconstruction image of the second sampling rate stored in the second buffer 48.

The video decoding apparatus 40 according to an embodiment may include a central processor (not shown) to generally control the bitstream obtainer 42, the predictor 43, the reconstructor 46, the first buffer 47, and the second buffer 48. Alternatively, the bitstream obtainer 42, the predictor 43, the reconstructor 46, the first buffer 47, and the second buffer 48 operate due to respective dedicated-processors (not shown), and the processors (not shown) systemically operate with each other so that the entire video decoding apparatus 40 may operate. Alternatively, the bitstream obtainer 42, the predictor 43, the reconstructor 46, the first buffer 47, and the second buffer 48 may be controlled by the control of an external processor (not shown) of the video decoding apparatus 40 according to an embodiment.

The video decoding apparatus 40 according to an embodiment may include one or more data storages (not shown) in which input and output data of the bitstream obtainer 42, the predictor 43, the reconstructor 46, the first buffer 47, and the second buffer 48 are stored. The video decoding apparatus 40 may include a memory controller (not shown) to manage data input and output of the data storages (not shown).

In order to reconstruct a video through video decoding, the video decoding apparatus 40 according to an embodiment may operate in cooperation with an internal video decoding processor installed therein or an external video decoding processor so as to perform video decoding operations. The internal video decoding processor of the video decoding apparatus 40 according to an embodiment may perform, as a separate processor, basic video decoding operations. Also, the basic video encoding operations may be realized as the video decoding apparatus 40, a central processing apparatus, or a graphic processing apparatus includes a video decoding processing module.

FIG. 2D is a flowchart of a video decoding method, according to an embodiment.

In operation 2100, when the video decoding apparatus 40 intra predicts a current block, the video decoding apparatus 40 generates a prediction block of the current block by using a block that is previously decoded at a first sampling rate and then is stored in a buffer.

In operation 2300, the video decoding apparatus 40 determines a residue of the first sampling rate by using the prediction block of the current block.

In operation 2500, the video decoding apparatus 40 generates a bitstream including the determined residue of the first sampling rate.

When the video decoding apparatus 40 inter predicts the current block, the video decoding apparatus 40 may generate the prediction block of the current block by using a block that is previously decoded at a second sampling rate. In this regard, the second sampling rate indicates a sampling rate different from the first sampling rate. For example, the first sampling rate may be higher than the second sampling rate.

After the video decoding apparatus 40 generates the prediction block of the current block of which sampling rate is the second sampling rate by using an image that is previously decoded at the second sampling rate, the video decoding apparatus 40 may generate a prediction block of which sampling rate is the first sampling rate by using the prediction block of the second sampling rate. That is, the video decoding apparatus 40 may change the prediction block of the second sampling rate to the first sampling rate, thereby generating the prediction block of the first sampling rate.

When the video decoding apparatus 40 according to an embodiment intra predicts the current block, the video decoding apparatus 40 generates the prediction block of the first sampling rate by using a block that is previously decoded at the first sampling rate higher than the second sampling rate that is processible based on a processing capability of the video decoding apparatus 40.

Thus, the video decoding apparatus 40 obtains the bitstream including the residue of the first sampling rate higher than the second sampling rate that is processible based on the processing capability of the video decoding apparatus 40, so that an image-quality deterioration phenomenon that may occur in reconstruction of an image may be minimized.

When inter prediction is performed based on the processing capability of the video decoding apparatus 40, a processible sampling rate is proportional to power consumption of a video decoding apparatus. This is because the sampling rate is proportional to the number of processed samples, and the number of processed samples is proportional to the power consumption used when the inter prediction is performed. When the video decoding apparatus 40 performs the inter prediction, the video decoding apparatus 40 generates the prediction block of the second sampling rate by using the image that is previously decoded at the second sampling rate. Because the video decoding apparatus 40 uses the second sampling rate lower than the first sampling rate during the inter prediction, power consumption may be sharply reduced compared to a case of using the first sampling rate.

FIG. 3 is a block diagram for describing an operation of a video decoding apparatus that decodes a high bit-depth bitstream, according to an embodiment.

A video decoding apparatus 3000 according to an embodiment may include an inverse-quantizer 3010, an inverse-transformer 3020, a bit-depth changer 3030, a clipping performer 3040, a reference pixel buffer 3050, a bit-depth changer 3060, an intra predictor 3070, a deblocking filter 3080, a sample adaptive offset (SAO) performer 3090, a reference picture buffer 3100, an inter predictor 3110, and a bit-depth changer 3120.

The inverse-quantizer 3010 inverse-quantizes a coefficient included in a current block. The coefficient included in the current block may be obtained from a bitstream.

The inverse-quantizer 3010 may obtain a quantization parameter, and may inverse-quantize the coefficient by using the obtained quantization parameter. For example, the inverse-quantizer 3010 may inverse-quantize the coefficient. When the coefficient of a first bit-depth obtained from the bitstream is inverse-quantized, a transform coefficient of the first bit-depth may be generated. In this regard, the first bit-depth may be 10.

The inverse-transformer 3020 inverse-transforms the inverse-quantized coefficient from a transform domain to a spatial domain, thereby generating the inverse-transformed coefficient. The inverse-transformed coefficient may indicate a residue of respect to the coefficient in the spatial domain. For example, the inverse-transformer 3020 may inverse-transform the inverse-quantized coefficient of the first bit-depth, thereby generating the residue of the first bit-depth.

The residue with respect to the coefficient is determined to be a positive value or a negative value according to a sign bit. Thus, the residue with respect to the inverse-transformed coefficient may be expressed with respect to a bit obtained by adding the sign bit to a bit based on a bit-depth.

A prediction block generated by the intra predictor 3070 may be a prediction block of the first bit-depth. A prediction

block generated by the bit-depth changer **3120** through the inter predictor **3110** may be a prediction block of the first bit-depth.

The video decoding apparatus **3000** may reconstruct the coefficient of the first bit-depth by using the prediction block of the first bit-depth and the residue with respect to the inverse-transformed coefficient. That is, the video decoding apparatus **3000** may reconstruct the coefficient of the first bit-depth by summing a sample value of the prediction block of the first bit-depth and a sample value of the residue with respect to the inverse-transformed coefficient.

The video decoding apparatus **3000** may reconstruct the current block of the first bit-depth which includes one or more coefficients reconstructed at the first bit-depth.

The bit-depth changer **3030** may change the current block reconstructed at the first bit-depth to a second bit-depth. Because a sample value expressed with respect to a large number of bits is expressed with respect to a small number of bits, a loss of information may occur. In this regard, the second bit-depth means a depth different from the first bit-depth. The second bit-depth may be lower than the first bit-depth. For example, the second bit-depth may be 8.

The bit-depth changer **3030** performs a right shift operation on the reconstructed coefficient of the first bit-depth, thereby changing the coefficient to a coefficient of the second bit-depth.

When the sample value of the prediction block of the first bit-depth and the sample value of the residue with respect to the inverse-transformed coefficient are summed, a summed sample value may exceed a range of sample values expressed with respect to a bit-depth.

When the reconstructed sample value exceeds a range of sample values expressed with respect to the second bit-depth, the clipping performer **3040** may change the value to a value that is from among values that can be expressed with respect to the second bit-depth and is closest to the sample value. For example, when a reconstructed coefficient of a bit-depth of 8 is 258, the value may be changed to 255 that is closest to 258 and is expressed with respect to a bit-depth of 8.

The reference pixel buffer **3050** may store the coefficient of the second bit-depth. The bit-depth changer **3060** may change the coefficient of the second bit-depth, which is stored in the reference pixel buffer **3050**, to the first bit-depth. For example, the bit-depth changer **3060** may change a coefficient of which bit-depth is 8 and is stored in the reference pixel buffer **3050** to a coefficient of which bit-depth is 10.

When the bit-depth changer **3060** changes to a higher bit-depth, the bit-depth changer **3060** may perform a left shift operation on a bit based on a predetermined bit-depth, and may allocate 0 to an empty space created due to the shift operation, thereby changing a bit-depth.

The intra predictor **3070** may intra predict the current block by using a previously-reconstructed coefficient. In this regard, a prediction block of the current block may be generated by using the coefficient changed to the first bit-depth by the bit-depth changer **3060**.

The deblocking filter **3080** performs deblocking filtering on reconstruction blocks of the current block, the reconstruction blocks including reconstructed coefficients. In this regard, deblocking filtering means filtering performed on boundaries of reconstruction blocks so as to improve blocking deterioration that is a distortion phenomenon in which discontinuities occur according to values of quantization parameters at the boundaries of the reconstruction blocks.

In this regard, the deblocking filter **3080** performs deblocking filtering on the reconstruction blocks including the coefficients reconstructed at the second bit-depth.

The SAO performer **3090** adjusts sample values of deblocking-filtered blocks, thereby reconstructing an image close to an original image. The SAO performer **3090** adjusts the sample values of the reconstruction blocks that are deblocking filtered at the second bit-depth by the deblocking filter **3080**, thereby reconstructing an image close to the original image. In this regard, the image that is reconstructed at the second bit-depth is output.

The reference picture buffer **3100** stores the reconstruction image including the sample values adjusted by the SAO performer **3090**. For example, the reference picture buffer **3100** may store the reconstruction image of the second bit-depth.

The inter predictor **3110** generates the prediction block of the current block included in a current image, by using the image that is decoded before the current image and then is stored in the reference picture buffer **3100**. The inter predictor **3110** inter predicts the current block by using the reconstruction image of the second bit-depth which is stored in the reference picture buffer **3100**.

The bit-depth changer **3120** changes the prediction block of the second bit-depth, which is changed by the inter predictor **3110**, to the first bit-depth.

The prediction blocks of the current block generated by the intra predictor **3070** and the bit-depth changer **3120** may all correspond to the first bit-depth. Thus, a block may be reconstructed at the first bit-depth by using the prediction blocks of the first bit-depth and the inverse-transformed coefficient.

A region **3200** indicates an area that is processible at the second bit-depth. That is, because the region **3200** is processed at the second bit-depth, some modules processing at the second bit-depth which are included in a low-cost video decoding apparatus may be reused.

If the inter predictor **3110** included in the region **3200** does not use a reconstruction image of the second bit-depth but uses an image reconstructed at the first bit-depth, power consumption by the inter predictor **3110** that uses a bus interface is sharply increased. Equally, because modules such as the deblocking filter **3080** and the SAO performer **3090** also use the bus interface, if blocks reconstructed at the second bit-depth are used, required power consumption is sharply increased. Thus, when an operation is performed at a low bit-depth in the region **3200** that uses a considerable amount of power, efficiency of power consumption may be increased.

FIG. 4 is a block diagram for describing an operation of a video decoding apparatus that decodes a high bit-depth bitstream, according to another embodiment.

When the video decoding apparatus **3000** illustrated in FIG. 3 intra predicts a current block, the video decoding apparatus **3000** changes blocks, which are previously decoded at a lower second bit-depth and then are stored, to a high first bit-depth, and performs intra prediction by using the changed blocks of the first bit-depth. In this regard, because a bit-depth of the block stored in a reference pixel buffer is decreased, information is lost, and even if it is changed to the first bit-depth, the lossy information cannot be restored. Thus, a prediction block generated through the intra prediction has a low correlation with an original block, an image-quality deterioration phenomenon occurs, in which an image quality significantly deteriorates compared

to an image quality of an image reconstructed through intra prediction using a block that is previously decoded at the first bit-depth.

Referring to FIG. 4, unlike to FIG. 3, a region 4200 in which an operation is performed at a first bit-depth includes a reference pixel buffer 4040 and an intra predictor 4050. That is, the intra predictor 4050 generates a prediction block of a current block by using a reconstruction block of a first bit-depth which is stored in the reference pixel buffer 4040. Unlike to the reference pixel buffer 3050 illustrated in FIG. 3, the reference pixel buffer 4040 does not store a reconstruction block changed to a second bit-depth but stores the reconstruction block of the first bit-depth.

Because the intra predictor 4050 generates a prediction block of the first bit-depth by using a block of the first bit-depth, the block being previously reconstructed and then stored in the reference pixel buffer 4040, an image-quality deterioration phenomenon of an image may be minimized.

Because only some modules among modules included in a video decoding apparatus 4000 operate at the first bit-depth, costs may be reduced by changing only some modules of a video decoding apparatus which support a second bit-depth. In addition, an inter predictor 4100, a deblocking filter 4070, and a SAO performer 4080 which occupy a considerable portion in power consumption by using a bus interface perform a process at a second bit-depth, so that an apparatus of a low power consumption may be embodied.

Referring to FIG. 4, the video decoding apparatus 4000 according to an embodiment may include an inverse-quantizer 4010, an inverse-transformer 4020, a clipping performer 4030, the reference pixel buffer 4040, an intra predictor 4050, a bit-depth changer 4060, the deblocking filter 4070, the SAO performer 4080, a reference picture buffer 4090, the inter predictor 4100, and a bit-depth changer 4110.

The inverse-quantizer 4010 inverse-quantizes a block including at least one coefficient obtained from a bitstream. The inverse-quantizer 4010 may obtain a quantization parameter, and may inverse-quantize the coefficient by using the obtained quantization parameter. The quantization parameter may be obtained from the bitstream.

For example, the inverse-quantizer 4010 may inverse-quantize the coefficient of a first bit-depth included in the bitstream, thereby obtaining the inverse-quantized coefficient of the first bit-depth. The inverse-quantized coefficient of the first bit-depth may be a transform coefficient of the first bit-depth.

The inverse-transformer 4020 inverse-transforms the inverse-quantized coefficient from a transform domain to a spatial domain, thereby generating the inverse-transformed coefficient. In this regard, the inverse-transformed coefficient may indicate a residue with respect to a coefficient.

For example, the inverse-transformer 4020 inverse-transforms the inverse-quantized coefficient from the transform domain to the spatial domain, thereby generating the inverse-transformed coefficient of the first bit-depth. In this regard, the first bit-depth may be 10. The inverse-transformed coefficient may indicate the residue with respect to the coefficient of the first bit-depth in the spatial domain. In this regard, the first bit-depth of the inverse-transformed coefficient may be 10. The residue with respect to the coefficient obtained after inverse-transformation is determined to have a positive value or a negative value according to a sign bit. Thus, the residue with respect to the inverse-transformed coefficient may be expressed with respect to a bit obtained by adding the sign bit to a bit based on a bit-depth.

The prediction block generated by the intra predictor 4050 may be a prediction block of the first bit-depth. In addition, a prediction block generated by the bit-depth changer 4110 through the inter predictor 4100 may be a prediction block of the first bit-depth.

The video decoding apparatus 4000 may reconstruct the coefficient of the first bit-depth by using the prediction block of the first bit-depth and the residue with respect to the inverse-transformed coefficient. The video decoding apparatus 4000 may reconstruct the coefficient of the first bit-depth by summing a sample value of the prediction block of the first bit-depth and a sample value of the residue with respect to the inverse-transformed coefficient. The video decoding apparatus 4000 may reconstruct the block of the first bit-depth which includes one or more coefficients reconstructed at the first bit-depth.

When the sample value of the prediction block of the first bit-depth and the sample value of the residue with respect to the inverse-transformed coefficient are summed, a summed sample value may exceed a range of sample values expressed with respect to a bit-depth.

When the summed sample value exceeds the range of the sample values expressed with respect to the bit-depth, the clipping performer 4030 may change the value to a value that is from among values that can be expressed with respect to the bit-depth and is closest to the sample value. When the summed sample value exceeds a range of sample values expressed with respect to the bit-depth, the clipping performer 4030 may change the value to a value that is from among values that can be expressed with respect to the first bit-depth and is closest to the sample value.

For example, when a reconstructed coefficient of a first bit-depth is 1028, the value may be changed to 1023 that is closest to 1028 and is expressed with respect to a bit-depth of 10.

The reference pixel buffer 4040 may store the coefficient reconstructed at the first bit-depth. The reference pixel buffer 4040 may store a block including the at least one coefficient reconstructed at the first bit-depth.

The intra predictor 4050 may reconstruct the current block by using the coefficient that is previously reconstructed and then is stored in the reference pixel buffer 4040.

The bit-depth changer 4060 may change the coefficient reconstructed at the first bit-depth to the second bit-depth. Because a sample value expressed with respect to a large number of bits is expressed with respect to a small number of bits, a loss of information may occur. For example, the bit-depth changer 4060 performs a right shift operation on the reconstructed coefficient of the first bit-depth, thereby changing the coefficient to a coefficient of the second bit-depth.

The deblocking filter 4070 performs deblocking filtering on reconstruction blocks including reconstructed coefficients. In this regard, the deblocking filter 4070 performs deblocking filtering on reconstruction blocks including coefficients reconstructed at the second bit-depth.

The SAO performer 4080 adjusts sample values of deblocking-filtered blocks, thereby reconstructing an image close to an original image. The SAO performer 4080 adjusts the sample values of the reconstruction blocks that are deblocking filtered at the second bit-depth by the deblocking filter 4070, thereby reconstructing an image close to the original image. In this regard, the image that is reconstructed at the second bit-depth is output.

The reference picture buffer 4090 stores the reconstruction image including the sample values adjusted by the SAO

performer **4080**. For example, the reference picture buffer **4090** may store the reconstruction image of the second bit-depth.

The inter predictor **4100** generates the prediction block of the current block by using the image stored in the reference picture buffer **4090**. The inter predictor **4100** inter predicts the current block by using the reconstruction image of the second bit-depth which is stored in the reference picture buffer **4090**. The bit-depth changer **4110** changes the prediction block of the second bit-depth, which is changed by the inter predictor **4100**, to the first bit-depth.

Bit-depths of the prediction blocks generated by the intra predictor **4050** and the bit-depth changer **4110** may all correspond to the first bit-depth. Thus, the block of the first bit-depth may be reconstructed by using the prediction blocks of the first bit-depth and the inverse-transformed coefficient.

FIG. 5 is a block diagram for describing an operation of a video decoding apparatus that decodes a high sampling rate bitstream, according to another embodiment.

Referring to FIG. 5, a video decoding apparatus **5000** according to an embodiment may include an inverse-quantizer **5010**, an inverse-transformer **5020**, a clipping performer **5030**, a reference pixel buffer **5040**, an intra predictor **5050**, a sampling rate changer **5060**, a deblocking filter **5070**, a SAO performer **5080**, a reference picture buffer **5090**, an inter predictor **5100**, and a sampling rate changer **5110**.

The inverse-quantizer **5010** inverse-quantizes a block including a coefficient obtained from a bitstream.

The inverse-quantizer **5010** may obtain a quantization parameter, and may inverse-quantize the coefficient by using the quantization parameter. For example, the inverse-quantizer **5010** may inverse-quantize the coefficient of a first sampling rate which is obtained from the bitstream, thereby obtaining the inverse-quantized coefficient of the first sampling rate. The inverse-quantized coefficient of the first sampling rate may be a transform coefficient of the first sampling rate. The inverse-transformer **5020** inverse-transforms the inverse-quantized coefficient from a transform domain to a spatial domain, thereby generating the inverse-transformed coefficient. In this regard, the inverse-transformed coefficient may indicate a residue with respect to a coefficient in the spatial domain.

For example, the inverse-transformer **5020** inverse-transforms the inverse-quantized coefficient from the transform domain to the spatial domain, thereby generating the residue with respect to the coefficient of the first sampling rate. In this regard, the first sampling rate of the inverse-transformed transform coefficient may be a sampling rate according to a luma-chroma sampling ratio of 4:2:2.

All of prediction blocks generated by the intra predictor **5050** and the inverse-quantizer **5010** may be prediction blocks of the first sampling rate. The video decoding apparatus **5000** may reconstruct the coefficient of the first sampling rate by using the prediction block of the first sampling rate and the residue with respect to the inverse-transformed coefficient. The video decoding apparatus **5000** may reconstruct the coefficient of the first sampling rate by summing a sample value of the prediction block of the first sampling rate and a sample value of the residue with respect to the inverse-transformed coefficient. The video decoding apparatus **5000** may reconstruct the block of the first sampling rate which includes the coefficient of the first sampling rate.

When the sample value of the prediction block of the first sampling rate and the sample value of the residue with respect to the inverse-transformed coefficient are summed, a

sample value thereof may exceed a range of sample values expressed with respect to a predetermined bit-depth.

When the sample value thereof exceeds the range of the sample values expressed with respect to the predetermined bit-depth, the clipping performer **5030** may change the value to a value that is from among values that can be expressed with respect to the predetermined bit-depth and is closest to the sample value. For example, when a reconstructed coefficient is 1028, the value may be changed to 1023 that is closest to 1028 and is expressed with respect to a predetermined bit-depth of 10.

The reference pixel buffer **5040** may store the coefficient reconstructed at the first sampling rate. For example, the reference pixel buffer **5040** may store the coefficient reconstructed at the luma-chroma sampling ratio of 4:2:2. The intra predictor **5050** may perform intra prediction on the current block by using the coefficient of the first sampling rate which is previously reconstructed and then is stored in the reference pixel buffer **5040**.

The sampling rate changer **5060** may change the coefficient reconstructed at the first sampling rate to a second sampling rate. In this regard, a change from a high sampling rate to a low sampling rate is performed in a manner that some samples among samples that are reconstructed at the high sampling rate are not used, thus, a loss of information occurs. In this regard, the second sampling rate means a sampling rate different from the first sampling rate, and the second sampling rate may be lower than the first sampling rate. For example, the second sampling rate may be a luma-chroma sampling ratio of 4:2:0.

For example, the sampling rate changer **5060** may change the first sampling rate to the second sampling rate by performing a downsampling operation so as not to use some samples that are reconstructed at the first sampling rate.

The deblocking filter **5070** performs deblocking filtering on reconstruction blocks including reconstructed coefficients. In this regard, the deblocking filter **5070** performs deblocking filtering on reconstruction blocks including coefficients reconstructed at the second sampling rate.

The SAO performer **5080** adjusts sample values of deblocking-filtered blocks, thereby reconstructing an image close to an original image. The SAO performer **5080** adjusts the sample values of the reconstruction blocks that are deblocking filtered at the second sampling rate by the deblocking filter **5070**, thereby reconstructing an image close to the original image. In this regard, the image that is reconstructed at the second sampling rate is output.

The reference picture buffer **5090** stores the reconstruction image including the sample values adjusted by the SAO performer **5080**. In this regard, an image stored in the reference picture buffer **5090** may be the image reconstructed at the second sampling rate.

The inter predictor **5100** generates the prediction block of the current block by using the image of the second sampling rate which is stored in the reference picture buffer **5090**. The inter predictor **5100** inter predicts the current block by using the reconstruction image of the second sampling rate which is stored in the reference picture buffer **5090**.

The sampling rate changer **5110** changes the prediction block of the second sampling rate, which is changed by the inter predictor **5100**, to the first sampling rate.

Sampling rates of the prediction blocks generated by the intra predictor **5050** and the sampling rate changer **5110** may all correspond to the first sampling rate. Thus, the block of the first sampling rate may be reconstructed by using the prediction blocks of the first sampling rate and the inverse-transformed coefficient.

A region **5200** in which an operation is performed at the first sampling rate includes the reference pixel buffer **5040** and the intra predictor **5050**.

That is, the intra predictor **5050** generates the prediction block of the current block by using the reconstruction block of the first sampling rate which is stored in the reference pixel buffer **5040**. The reference pixel buffer **5040** does not store the reconstruction block changed to the second sampling rate but stores the reconstruction block of the first sampling rate. Because the intra predictor **5050** generates the prediction block of the current block by using the reconstruction block of the first sampling rate which is previously decoded and then is stored in the reference pixel buffer **5040**, an image-quality deterioration phenomenon of an image may be minimized.

Because only some modules among modules included in the video decoding apparatus **5000** operate at the first sampling rate, costs may be reduced by changelessly using some modules of a video decoding apparatus which are processed at a second sampling rate. In addition, the inter predictor **5100**, the deblocking filter **5070**, and the SAO performer **5080** which occupy a considerable portion in power consumption by using a bus interface perform a process at a second sampling rate, so that an apparatus of a low power consumption may be embodied.

FIG. **6A** is a diagram for describing a process of decoding a high sampling rate bitstream while varying an intra prediction scheme according to a type of a pixel to be currently predicted, according to another embodiment.

Referring to FIG. **6A**, unlike the intra predictor **5050** illustrated in FIG. **5**, a video decoding apparatus **6000** includes a first intra predictor **6050** and a second intra predictor **6080**. In addition, unlike the reference pixel buffer **5040** illustrated in FIG. **5**, the video decoding apparatus **6000** includes a first reference pixel buffer **6040** and a second reference pixel buffer **6070**. That is, the video decoding apparatus **6000** includes the first intra predictor **6050** and the second intra predictor **6080** which change an intra prediction scheme according to a type of a pixel to be currently predicted. The video decoding apparatus **6000** includes the first reference pixel buffer **6040** and the second reference pixel buffer **6070** which store blocks with different sampling rates.

The first reference pixel buffer **6040** stores a reconstruction block of a first sampling rate. The second reference pixel buffer **6070** stores a block changed from the first sampling rate to a second sampling rate.

When the first intra predictor **6050** intra predicts reference pixels that are from among pixels included in a current pixel and are to be used in a block to be decoded thereafter, the first intra predictor **6050** may predict the reference pixels by using a block that is previously decoded at the first sampling rate and then is stored in the first reference pixel buffer **6040**. In this regard, the reference pixels predicted by the first intra predictor **6050** may be predicted at the first sampling rate. For example, the predicted reference pixels may be samples of which luma-chroma sampling ratio is 4:2:2. Detailed descriptions with respect to determining, by the first intra predictor **6050**, the reference pixels from among the pixels included in the current block will be provided with reference to FIG. **6B**. The pixels excluding the reference pixels may be pixels that are not used in intra predicting the block to be decoded thereafter. Hereinafter, the pixels are referred to as non-reference pixels.

When the second intra predictor **6080** intra predicts the non-reference pixels from among the pixels included in the current block, the second intra predictor **6080** may predict

the non-reference pixel by using the block that is previously decoded at the second sampling rate and thus is stored in the second reference pixel buffer **6070**. In this regard, the non-reference pixels predicted by the second intra predictor **6080** may be predicted at the second sampling rate. For example, decoded non-reference pixels may be samples of which luma-chroma sampling ratio is 4:2:0. When the second intra predictor **6080** intra predicts the current block, the second intra predictor **6080** may obtain a prediction direction with respect to the current block from a bitstream. The obtained prediction direction may be a prediction direction determined based on the first sampling rate. In order to intra predict the non-reference pixels at the second sampling rate, prediction has to be performed by changing the prediction direction determined based on the first sampling rate. Descriptions with respect to changing, by the second intra predictor **6080**, the prediction direction based on the first sampling rate will be described with reference to FIG. **6E**.

The video decoding apparatus **6000** according to an embodiment may include an inverse-quantizer **6010**, an inverse-transformer **6020**, a clipping performer **6030**, a sampling rate changer **6060**, the first reference pixel buffer **6040**, the first intra predictor **6050**, the second reference pixel buffer **6070**, the second intra predictor **6080**, a sampling rate changer **6090**, a deblocking filter **6100**, a SAO performer **6110**, a reference picture buffer **6120**, an inter predictor **6130**, and a sampling rate changer **6140**.

The inverse-quantizer **6010** inverse-quantizes a coefficient obtained from the bitstream. In this regard, the inverse-quantizer **6010** may inverse-quantize the coefficient by using a predetermined quantization parameter. For example, the inverse-quantizer **6010** may inverse-quantize the coefficient of a first sampling rate which is obtained from the bitstream, thereby obtaining the inverse-quantized coefficient of the first sampling rate. The inverse-quantized coefficient of the first sampling rate may be a transform coefficient of the first sampling rate.

The inverse-transformer **6020** inverse-transforms the inverse-quantized coefficient from a transform domain to a spatial domain, thereby generating the inverse-transformed coefficient in the spatial domain. The inverse-transformed coefficient may indicate a residue with respect to the coefficient in the spatial domain.

For example, the inverse-transformer **6020** may inverse-transform the inverse-quantized coefficient of the first sampling rate. In this regard, a sampling rate of the inverse-transformed transform coefficient may be a luma-chroma sampling ratio of 4:2:2.

All prediction blocks generated by the first intra predictor **6050** and the sampling rate changers **6090** and **6140** may be prediction blocks of the first sampling rate. The video decoding apparatus **6000** may reconstruct the coefficient of the first sampling rate by using the prediction block of the first sampling rate and the residue with respect to the inverse-transformed coefficient. The video decoding apparatus **6000** may reconstruct the coefficient of the first sampling rate by summing a sample value of the prediction block of the first sampling rate and a sample value of the residue with respect to the inverse-transformed coefficient. The video decoding apparatus **6000** may reconstruct the block of the first sampling rate which includes one or more coefficients reconstructed at the first sampling rate.

When the sample value of the prediction block of the first sampling rate and the sample value of the residue with respect to the inverse-transformed coefficient are summed, a sample value thereof may exceed a range of sample values expressed with respect to a predetermined bit-depth.

When the sample value thereof exceeds the range of the sample values expressed with respect to the predetermined bit-depth, the clipping performer **6030** may change the value to a value that is from among values that can be expressed with respect to the predetermined bit-depth and is closest to the sample value. For example, when a reconstructed coefficient is 1028, the value may be changed to 1023 that is closest to 1028 and is expressed with respect to a predetermined bit-depth of 10.

The first reference pixel buffer **6040** may store the coefficient reconstructed at the first sampling rate. For example, the first reference pixel buffer **6040** may store the coefficient reconstructed at the luma-chroma sampling ratio of 4:2:2. In this regard, a neighboring pixel (i.e., the reference pixel) of the current block which is usable in predicting the current block and is from among the previously-reconstructed blocks may be the coefficient that is intra predicted and reconstructed at the luma-chroma sampling ratio of 4:2:2, and may be stored in the first reference pixel buffer **6040**.

The first intra predictor **6050** may intra predict some pixels included in the current block by using the coefficient of the first sampling rate which is previously reconstructed and then is stored in the first reference pixel buffer **6040**.

The sampling rate changer **6060** may change the coefficient reconstructed at the first sampling rate to a second sampling rate. In this regard, a change from a high sampling rate to a low sampling rate is performed in a manner that some samples among samples that are reconstructed at the high sampling rate are discarded, thus, a loss of information occurs.

For example, the sampling rate changer **6060** may change the first sampling rate to the second sampling rate by performing a downsampling operation so as not to use some samples that are reconstructed at the first sampling rate.

The second reference pixel buffer **6070** may store a reconstruction block including the coefficient changed to the second sampling rate by the sampling rate changer **6060**.

The second intra predictor **6080** may intra predict some pixels with the second sampling rate included in the current block, by using a coefficient of the second sampling rate which is previously reconstructed and then is stored in the second reference pixel buffer **6070**. The sampling rate changer **6090** may change the block, which is predicted at the second sampling rate by the second intra predictor **6080**, to the first sampling rate. For example, the sampling rate changer **6090** may reconstruct a block at a luma-chroma sampling ratio of 4:2:2, the block having been predicted at a luma-chroma sampling ratio of 4:2:0.

The deblocking filter **6100** performs deblocking filtering on reconstruction blocks including reconstructed coefficients. In this regard, the deblocking filter **6100** performs deblocking filtering on reconstruction blocks including coefficients reconstructed at the second sampling rate.

The SAO performer **6110** adjusts sample values of deblocking-filtered blocks, thereby reconstructing an image close to an original image. The SAO performer **6110** adjusts the sample values of the reconstruction blocks that are deblocking filtered at the second sampling rate by the deblocking filter **6100**, thereby reconstructing an image close to the original image. In this regard, the image that is reconstructed at the second sampling rate is output.

The reference picture buffer **6120** stores the reconstruction image including the sample values adjusted by the SAO performer **6110**. In this regard, an image stored in the reference picture buffer **6120** may be the image reconstructed at the second sampling rate.

The inter predictor **6130** generates the prediction block of the current block by using the image of the second sampling rate which is stored in the reference picture buffer **6120**.

The sampling rate changer **6140** changes the prediction block of the second sampling rate, which is generated by the inter predictor **6130**, to the first sampling rate.

Sampling rates of the prediction blocks generated by the first intra predictor **6050** and the sampling rate changers **6090** and **6140** may be the first sampling rate. Thus, the block may be reconstructed at the first sampling rate by using the prediction block of the first sampling rate and the inverse-transformed transform coefficient.

Referring to FIG. 6A, a region **6200** in which a process is performed at the first sampling rate includes the first reference pixel buffer **6040** and the first intra predictor **6050**.

The first intra predictor **6050** generates the reference pixels included in the current block by using the reconstruction block of the first sampling rate which is stored in the first reference pixel buffer **6040**. The first reference pixel buffer **6040** does not store the reconstruction block changed to the second sampling rate but stores the reconstruction block of the first sampling rate.

Because the first intra predictor **6050** predicts the reference pixels included in the current block by using the reconstruction block of the first sampling rate which is previously decoded and then is stored in the first reference pixel buffer **6040**, an image-quality deterioration phenomenon of an image may be minimized.

In more detail, because the reference pixels are generated by using the reconstruction block of the first sampling rate, an image-quality deterioration phenomenon of an image which occurs in the reference pixels may be minimized, and when intra prediction is performed in a block to be decoded thereafter, the reference pixels decoded at the first sampling rate are used so that an image-quality deterioration phenomenon of an image of the block to be decoded thereafter may be minimized.

The second intra predictor **6080** predicts the non-reference pixels included in the current block by using the reconstruction block of the second sampling rate which is previously decoded and then is stored in the second reference pixel buffer **6070**. In this regard, the non-reference pixels indicate pixels that are predicted at the second sampling rate and are not used in intra predicting the block to be decoded thereafter, the pixels being from among pixels included in the current block.

Because the non-reference pixels are predicted at the second sampling rate, the number of predicted samples is decreased compared to a case of performing intra prediction at the first sampling rate as illustrated in FIG. 5, so that computation may be efficiently decreased. Unlike the reference pixels, the non-reference pixels are not used in intra predicting the block to be decoded thereafter, so that an image-quality deterioration phenomenon due to the non-reference pixels may be minimized.

Because only some modules among modules included in the video decoding apparatus **6000** operate at the first sampling rate, costs may be reduced by changelessly using some modules of a video decoding apparatus which are processed at the second sampling rate. In addition, the inter predictor **6130**, the deblocking filter **6100**, and the SAO performer **6110** which occupy a considerable portion in power consumption by using a bus interface perform a process at the second sampling rate, so that an apparatus of a low power consumption may be embodied.

FIG. 6B is a diagram for describing a process of determining a reference pixel that is usable in intra predicting a

block to be decoded thereafter, according to another embodiment. It is assumed that the video decoding apparatus **6000** performs intra prediction so as to reconstruct a current block **6210**. (In this regard, a current block may be a block of a chroma component.)

Referring to FIG. **6B**, the video decoding apparatus **6000** may intra predict a current block by using a previously-reconstructed block.

As described above with reference to FIG. **6A**, the video decoding apparatus **6000** may determine whether to perform intra prediction by using a block reconstructed at a first sampling rate or to perform intra prediction by using a block reconstructed at a second sampling rate, according to a pixel type.

In more detail, the video decoding apparatus **6000** may determine a reference pixel that is from among pixels included in a current pixel and is to be used in intra predicting a block to be decoded after the current block.

Referring to FIG. **6B**, the block to be decoded after the current block **6210** is located at the right or the bottom of the current block **6210**. When the video decoding apparatus **6000** determines that the block to be decoded is to be intra predicted, the video decoding apparatus **6000** may predict the block to be decoded, by using pixels adjacent to the left or the top. In this regard, pixels of the current block **6210** which are included in a left region or an upper region of the block to be decoded after the current block **6210** are determined as reference pixels to be used in decoding the block to be decoded after the current block **6210**.

For example, when the video decoding apparatus **6000** intra predicts the block to be decoded after the current block **6210**, intra prediction may be performed by using pixels included in a left region **6230** or an upper region **6230** of the block to be decoded. That is, the pixels included in the region **6230** may be determined as reference pixels to be used in decoding the block to be decoded after the current block **6210**.

Thus, when the video decoding apparatus **6000** intra predicts the current block **6210**, the video decoding apparatus **6000** may intra predict the pixels included in the region **6230**, by using a block previously reconstructed at a first sampling rate.

The video decoding apparatus **6000** may intra predict non-reference pixels by using a block previously reconstructed at a second sampling rate. In this regard, pixels that are included in the current block and exclude the pixels included in the left region or the upper region of the block to be decoded after the current block may be determined as the non-reference pixels to be used in decoding the block after the current block.

For example, when the video decoding apparatus **6000** intra predicts the current block, the video decoding apparatus **6000** may intra predict, by using the previously-reconstructed block of the second sampling rate, residual pixels that exclude the pixels included in the region **6230** and are from among the pixels included in the current block **6210**.

Hereinafter, a process in which the video decoding apparatus **6000** decodes a current block based on a sampling rate will now be described.

The video decoding apparatus **6000** determines a size of the current block based on the sampling rate. The video decoding apparatus **6000** may determine the size of the current block, based on a residue of a first sampling rate which is obtained from a bitstream. The first sampling rate may be a sampling rate based on a luma-chroma sampling ratio of 4:2:2. In this regard, the size of the current block

may indicate a rectangular block that is vertically twice as large as a block based on a luma-chroma sampling ratio of 4:2:0.

The current block **6210** illustrated in FIG. **6B** is a block that is decoded assuming a case where the sampling rate indicates a sampling rate based on a luma-chroma sampling ratio of 4:2:2. It is obvious to one of ordinary skill in the art that, if the sampling rate indicates a sampling rate based on a luma-chroma sampling ratio of 4:2:0, a block **6240** may be the current block **6210**.

Hereinafter, with reference to FIGS. **6C** to **6D**, a process in which the video decoding apparatus **6000** decodes the current block **6210** at a luma-chroma sampling ratio of 4:2:2 will now be described. FIGS. **6C** to **6D** are diagrams for describing a decoding process by the current block **6210**, based on the luma-chroma sampling ratio of 4:2:2.

Referring to FIG. **6C**, when the video decoding apparatus **6000** performs intra prediction on a current block, the video decoding apparatus **6000** may perform prediction on a block with a square size. Thus, when the video decoding apparatus **6000** generates a prediction block of the current block **6210**, based on the luma-chroma sampling ratio of 4:2:2, the video decoding apparatus **6000** first generates a prediction block of the block **6240** by using some pixels from among pixels **6241** that are located in the left and the top of the block **6240** in a prediction direction **6220**, and reconstructs the block **6240** by using the prediction block.

Referring to FIG. **6D**, after the block **6240** is reconstructed, a prediction block of a block **6245** is generated by using some pixels from among pixels **6246** that are located in the left and the top of the block **6245** in the prediction direction **6220**. The video decoding apparatus **6000** reconstructs the block **6245** by using the prediction block of the block **6245**.

The video decoding apparatus **6000** may reconstruct the current block **6210** by using the reconstructed block **6240** and the reconstructed block **6245**. It is obvious to one of ordinary skill in the art that, if the sampling rate indicates a sampling rate based on a luma-chroma sampling ratio of 4:2:0, it is possible to reconstruct the current block **6210** by using the block **6240** that is reconstructed through the decoding process described with reference to FIG. **6C**, without performing the decoding process described with reference to FIG. **6D**.

FIG. **6E** is a diagram for describing a process in which a video decoding apparatus determines a prediction direction while intra predicting a non-reference pixel, according to another embodiment.

As described above with reference to FIG. **6A**, when the video decoding apparatus **6000** intra predicts a non-reference pixel from among pixels included in a current block, the video decoding apparatus **6000** may intra predict the non-reference pixel at a second sampling rate by using a block that is reconstructed at the second sampling rate.

The video decoding apparatus **6000** obtains, from a bitstream, a prediction direction of the current block determined based on a first sampling rate. Thus, in order to predict the non-reference pixel, the video decoding apparatus **6000** may change the obtained prediction direction of the first sampling rate to a prediction direction of the second sampling rate.

The reason why a prediction direction is changed based on a sampling rate is because, when intra prediction is performed from the first sampling rate to the second sampling rate, the number of pixels to be sampled is decreased such that the current block to be predicted and a size of neighboring block used in the prediction are decreased. The

video decoding apparatus **6000** may change the prediction direction by taking into account the decreased size of the block.

For example, referring to FIG. **6E**, when the first sampling rate indicates a luma-chroma sampling ratio of 4:2:2, a sample value of a chroma component is present only in an even column or an odd column.

When the second sampling rate indicates a luma-chroma sampling ratio of 4:2:0, a sample value of a chroma component is present only in one of an even row and an odd row or one of an even column and an odd column.

Thus, when the luma-chroma sampling ratio of 4:2:2 is compared to the luma-chroma sampling ratio of 4:2:0, if a luma-chroma sampling ratio is changed from 4:2:2 to 4:2:0, the number of samples in a vertical direction with respect to a chroma component is halved.

Referring to FIG. **6E**, in a case where the current block is reconstituted by re-arranging samples to contact each other with respect to a sample of the current block at the upper left end, when the luma-chroma sampling ratio is changed from the luma-chroma sampling ratio of 4:2:2 to the luma-chroma sampling ratio of 4:2:0, a size of the current block with respect to the chroma component is halved in a vertical direction.

Thus, when the luma-chroma sampling ratio is changed from 4:2:2 to 4:2:0, it is required to change a prediction direction of the luma-chroma sampling ratio of 4:2:2 to a prediction direction of 4:2:0, in consideration of a size of the reconstituted block.

For example, when an angle of a prediction direction with respect to the luma-chroma sampling ratio of 4:2:2 is 63.44 degrees ($\arctan(2)$) with respect to a horizontal direction, an angle of a prediction direction with respect to the luma-chroma sampling ratio of 4:2:0 may be determined to be 45 degrees ($\arctan(1)$), in consideration of the size of the block.

The video decoding apparatus **6000** may have in advance a predetermined change table indicating a prediction direction of a second sub-sampling rate which corresponds to a prediction direction of a first sub-sampling rate. The video decoding apparatus **6000** may determine the prediction direction of the second sub-sampling rate from the prediction direction of the first sub-sampling rate by using the predetermined change table.

When the video decoding apparatus according to an embodiment receives a bitstream and reconstructs an image by using the bitstream that includes a residue of a bit-depth higher than a processible bit-depth based on a processing capability of the video decoding apparatus, the video decoding apparatus includes some modules (e.g., an intra predictor and a reference pixel buffer, particularly, the reference pixel buffer) that support the bit-depth higher than the processible bit-depth based on the processing capability of the video decoding apparatus, so that an image-quality deterioration phenomenon may be minimized. In addition, the video decoding apparatus includes some modules (an inter predictor, an SAO performer, and a deblocking filter) that are processed at the processible bit-depth based on the processing capability, so that an apparatus of a low cost and low power consumption may be embodied.

When the video decoding apparatus according to an embodiment receives a bitstream and reconstructs an image by using the bitstream that includes a residue of a sampling rate higher than a processible sampling rate based on a processing capability of the video decoding apparatus, the video decoding apparatus includes some modules (e.g., an intra predictor and a reference pixel buffer, particularly, the

reference pixel buffer) that support the sampling rate higher than the processible sampling rate based on the processing capability of the video decoding apparatus, so that an image-quality deterioration phenomenon may be minimized. In addition, the video decoding apparatus includes some modules (an inter predictor, an SAO performer, and a deblocking filter) that are processed at the processible sampling rate based on the processing capability of the video decoding apparatus, so that an apparatus of a low cost and low power consumption may be embodied.

As described above, the video encoding apparatuses **10** and **30** according to an embodiment and the video decoding apparatuses **20** and **40** according to an embodiment split video data into largest coding units that are split blocks, and encode and decode each of the largest coding units based on coding units of a tree structure. Hereinafter, with reference to FIGS. **7** through **26**, examples of a video encoding scheme and a video decoding scheme based on coding units of a tree structure according to various embodiments will now be provided.

FIG. **7** illustrates a block diagram of a video encoding apparatus based on coding units of a tree structure **100**, according to an embodiment.

The video encoding apparatus involving video prediction based on coding units of the tree structure **100** includes a largest coding unit splitter **110**, a coding unit determiner **120**, and an output unit **130**. Hereinafter, for convenience of description, the video encoding apparatus involving video prediction based on coding units of the tree structure **100** is referred to as the 'video encoding apparatus **100**'.

The largest coding unit splitter **110** may split a current picture based on a largest coding unit that is a coding unit having a maximum size for a current picture of an image. If the current picture is larger than the largest coding unit, image data of the current picture may be split into the at least one largest coding unit. The largest coding unit according to an embodiment may be a data unit having a size of 32×32, 64×64, 128×128, 256×256, etc., wherein a shape of the data unit is a square having a width and length in powers of 2. Image data may be output to the coding unit determiner **120** according to the at least one largest coding unit.

A coding unit according to an embodiment may be characterized by a maximum size and a depth. The depth denotes the number of times the coding unit is spatially split from the largest coding unit, and as the depth deepens, deeper coding units according to depths may be split from the largest coding unit to a smallest coding unit. A depth of the largest coding unit may be defined as an uppermost depth and a depth of the smallest coding unit may be defined as a lowermost depth. Since a size of a coding unit corresponding to each depth decreases as the depth of the largest coding unit deepens, a coding unit corresponding to an upper depth may include a plurality of coding units corresponding to lower depths.

As described above, the image data of the current picture is split into the largest coding units according to a maximum size of the coding unit, and each of the largest coding units may include deeper coding units that are split according to depths. Since the largest coding unit according to an embodiment is split according to depths, the image data of a spatial domain included in the largest coding unit may be hierarchically classified according to depths.

A maximum depth and a maximum size of a coding unit, which limit the total number of times a height and a width of the largest coding unit are hierarchically split, may be predetermined.

The coding unit determiner **120** encodes at least one split region obtained by splitting a region of the largest coding unit according to depths, and determines a depth to output a finally encoded image data according to the at least one split region. That is, the coding unit determiner **120** determines a depth by encoding the image data in the deeper coding units according to depths, according to the largest coding unit of the current picture, and selecting a depth having the minimum encoding error. The determined depth and image data according to largest coding units are output to the output unit **130**.

The image data in the largest coding unit is encoded based on the deeper coding units corresponding to at least one depth equal to or below the maximum depth, and results of encoding the image data based on each of the deeper coding units are compared. A depth having the minimum encoding error may be selected after comparing encoding errors of the deeper coding units. At least one depth may be selected for each largest coding unit.

The size of the largest coding unit is split as a coding unit is hierarchically split according to depths, and as the number of coding units increases. Also, even if coding units correspond to the same depth in one largest coding unit, it is determined whether to split each of the coding units corresponding to the same depth to a lower depth by measuring an encoding error of the image data of the each coding unit, separately. Accordingly, even when image data is included in one largest coding unit, the encoding errors may differ according to regions in the one largest coding unit, and thus the depths may differ according to regions in the image data. Thus, one or more depths may be determined in one largest coding unit, and the image data of the largest coding unit may be divided according to coding units of at least one depth.

Accordingly, the coding unit determiner **120** according to the embodiment may determine coding units having a tree structure included in the current largest coding unit. The 'coding units having a tree structure' according to an embodiment include coding units corresponding to a depth determined to be the depth, from among all deeper coding units included in the current largest coding unit. A coding unit of a depth may be hierarchically determined according to depths in the same region of the largest coding unit, and may be independently determined in different regions. Equally, a depth in a current region may be independently determined from a depth in another region.

A maximum depth according to an embodiment is an index related to the number of splitting times from a largest coding unit to a smallest coding unit. A first maximum depth according to an embodiment may denote the total number of splitting times from the largest coding unit to the smallest coding unit. A second maximum depth according to an embodiment may denote the total number of depth levels from the largest coding unit to the smallest coding unit. For example, when a depth of the largest coding unit is 0, a depth of a coding unit, in which the largest coding unit is split once, may be set to 1, and a depth of a coding unit, in which the largest coding unit is split twice, may be set to 2. In this regard, if the smallest coding unit is a coding unit in which the largest coding unit is split four times, depth levels of depths 0, 1, 2, 3, and 4 exist, and thus the first maximum depth may be set to 4, and the second maximum depth may be set to 5.

Prediction encoding and transformation may be performed according to the largest coding unit. The prediction encoding and the transformation are also performed based

on the deeper coding units according to a depth equal to or depths less than the maximum depth, according to the largest coding unit.

Since the number of deeper coding units increases whenever the largest coding unit is split according to depths, encoding, including the prediction encoding and the transformation, is performed on all of the deeper coding units generated as the depth deepens. Hereinafter, for convenience of description, the prediction encoding and the transformation will be described based on a coding unit of a current depth in at least one largest coding unit.

The video encoding apparatus **100** according to the embodiment may variously select a size or shape of a data unit for encoding the image data. In order to encode the image data, operations, such as prediction encoding, transformation, and entropy encoding, are performed, and at this time, the same data unit may be used for all operations or different data units may be used for each operation.

For example, the video encoding apparatus **100** may select not only a coding unit for encoding the image data, but may also select a data unit different from the coding unit so as to perform the prediction encoding on the image data in the coding unit.

In order to perform prediction encoding in the largest coding unit, the prediction encoding may be performed based on a coding unit corresponding to a depth according to an embodiment, i.e., based on a coding unit that is no longer split to coding units corresponding to a lower depth. A prediction unit in a partition for prediction is determined from the coding unit. The prediction unit may include the coding unit and the partition obtained by splitting at least one of a height and width of the coding unit. The partition is a data unit where the prediction unit of the coding unit is split, and may have a same size as the coding unit.

For example, when a coding unit of $2N \times 2N$ (where N is a positive integer) is no longer split, it becomes a prediction unit of $2N \times 2N$, and a size of a partition may be $2N \times 2N$, $2N \times N$, $N \times 2N$, or $N \times N$. Examples of a partition mode may include symmetrical partitions obtained by symmetrically splitting a height or width of the prediction unit, and may selectively include partitions obtained by asymmetrically splitting the height or width of the prediction unit, such as $1:n$ or $n:1$, partitions obtained by geometrically splitting the prediction unit, partitions having arbitrary types, or the like.

A prediction mode of the prediction unit may be at least one of an intra mode, an inter mode, and a skip mode. For example, the intra mode and the inter mode may be performed on the partition of $2N \times 2N$, $2N \times N$, $N \times 2N$, or $N \times N$. Also, the skip mode may be performed only on the partition of $2N \times 2N$. The encoding may be independently performed on one prediction unit in a coding unit, so that a prediction mode having a minimum encoding error may be selected.

The video encoding apparatus **100** according to the embodiment may also perform the transformation on the image data in a coding unit based on not only the coding unit for encoding the image data, but also based on a data unit that is different from the coding unit. In order to perform the transformation in the coding unit, the transformation may be performed based on a transformation unit having a size smaller than or equal to the coding unit. For example, the transformation unit may include a data unit for an intra mode and a transformation unit for an inter mode.

The transformation unit in the coding unit may be recursively split into smaller sized regions in a manner similar to that in which the coding unit is split according to the tree structure, according to an embodiment. Thus, residual data

in the coding unit may be split according to the transformation unit having the tree structure according to transformation depths.

A transformation depth indicating the number of splitting times to reach the transformation unit by splitting the height and width of the coding unit may also be set in the transformation unit according to an embodiment. For example, in a current coding unit of $2N \times 2N$, a transformation depth may be 0 when the size of a transformation unit is $2N \times 2N$, may be 1 when the size of the transformation unit is $N \times N$, and may be 2 when the size of the transformation unit is $N/2 \times N/2$. That is, with respect to the transformation unit, the transformation unit having the tree structure may be set according to the transformation depths.

Encoding information according to depths requires not only information about a depth but also requires information related to prediction and transformation. Accordingly, the coding unit determiner **120** not only determines a depth having a minimum encoding error but also determines a partition mode in which a prediction unit is split to partitions, a prediction mode according to prediction units, and a size of a transformation unit for transformation.

Coding units according to a tree structure in a largest coding unit and methods of determining a prediction unit/partition, and a transformation unit, according to embodiments, will be described in detail later with reference to FIGS. 7 through 19.

The coding unit determiner **120** may measure an encoding error of deeper coding units according to depths by using Rate-Distortion Optimization based on Lagrangian multipliers.

The output unit **130** outputs, in bitstreams, the image data of the largest coding unit, which is encoded based on the at least one depth determined by the coding unit determiner **120**, and encoding mode information according to depths.

The encoded image data may correspond to a result obtained by encoding residual data of an image.

The encoding mode information according to depths may include depth information, partition mode information of the prediction unit, prediction mode information, and the size information of the transformation unit.

The depth information may be defined by using split information according to depths, which specifies whether encoding is performed on coding units of a lower depth instead of a current depth. If the current depth of the current coding unit is a depth, the current coding unit is encoded by using the coding unit of the current depth, and thus split information of the current depth may be defined not to split the current coding unit to a lower depth. On the contrary, if the current depth of the current coding unit is not the depth, the encoding has to be performed on the coding unit of the lower depth, and thus the split information of the current depth may be defined to split the current coding unit to the coding units of the lower depth.

If the current depth is not the depth, encoding is performed on the coding unit that is split into the coding unit of the lower depth. Since at least one coding unit of the lower depth exists in one coding unit of the current depth, the encoding is repeatedly performed on each coding unit of the lower depth, and thus the encoding may be recursively performed on the coding units having the same depth.

Since the coding units having a tree structure are determined for one largest coding unit, and at least one piece of encoding mode information has to be determined for a coding unit of a depth, at least one piece of encoding mode information may be determined for one largest coding unit. Also, data of the largest coding unit may vary according to

locations since the data is hierarchically split according to depths, and thus split information may be set for the data.

Accordingly, the output unit **130** according to the embodiment may assign split information to at least one of the coding unit, the prediction unit, and a minimum unit included in the largest coding unit.

The minimum unit according to an embodiment is a square data unit obtained by splitting the smallest coding unit constituting the lowermost depth by 4. Alternatively, the minimum unit according to an embodiment may be a maximum square data unit that may be included in all of the coding units, prediction units, partition units, and transformation units included in the largest coding unit.

For example, the encoding information output by the output unit **130** may be classified into encoding information according to deeper coding units, and encoding information according to prediction units. The encoding information according to the deeper coding units may include the prediction mode information and the partition size information. The encoding information according to the prediction units may include information about an estimated direction of an inter mode, about a reference image index of the inter mode, about a motion vector, about a chroma component of an intra mode, and about an interpolation method of the intra mode.

Information about a maximum size of the coding unit defined according to pictures, slices, or GOPs, and information about a maximum depth may be inserted into a header of a bitstream, a sequence parameter set, or a picture parameter set.

Information about a maximum size of the transformation unit permitted with respect to a current video, and information about a minimum size of the transformation unit may also be output through a header of a bitstream, a sequence parameter set, or a picture parameter set. The output unit **130** may encode and output an SAO parameter described above with reference to FIGS. 1A through 14.

According to the simplest embodiment of the video encoding apparatus **100**, the deeper coding unit may be a coding unit obtained by dividing a height and width of a coding unit of an upper depth, which is one layer above, by two. That is, when the size of the coding unit of the current depth is $2N \times 2N$, the size of the coding unit of the lower depth is $N \times N$. Also, a current coding unit having a size of $2N \times 2N$ may maximally include four lower-depth coding units having a size of $N \times N$.

Accordingly, the video encoding apparatus **100** may form the coding units having the tree structure by determining coding units having an optimum shape and an optimum size for each largest coding unit, based on the size of the largest coding unit and the maximum depth determined considering characteristics of the current picture. Also, since encoding may be performed on each largest coding unit by using any one of various prediction modes and transformations, an optimum encoding mode may be determined by taking into account characteristics of the coding unit of various image sizes.

Thus, if an image having a high resolution or a large data amount is encoded in a conventional macroblock, the number of macroblocks per picture excessively increases. Accordingly, the number of pieces of compressed information generated for each macroblock increases, and thus it is difficult to transmit the compressed information and data compression efficiency decreases. However, by using the video encoding apparatus according to the embodiment, image compression efficiency may be increased since a coding unit is adjusted while considering characteristics of

an image while increasing a maximum size of a coding unit while considering a size of the image.

The video encoding apparatus **100** of FIG. 7 may perform operations of the video encoding apparatuses **10** and **30** described above with reference to FIGS. 1A and 6.

FIG. 8 illustrates a block diagram of a video decoding apparatus based on coding units of a tree structure **200**, according to an embodiment.

The video decoding apparatus involving video prediction based on coding units of the tree structure **200** according to the embodiment includes a receiver **210**, an image data and encoding information extractor **220**, and an image data decoder **230**. Hereinafter, for convenience of description, the video decoding apparatus involving video prediction based on coding units of the tree structure **200** according to the embodiment is referred to as the 'video decoding apparatus **200**'.

Definitions of various terms, such as a coding unit, a depth, a prediction unit, a transformation unit, and various encoding mode information, for decoding operations of the video decoding apparatus **200** according to an embodiment are identical to those described with reference to FIG. 15 and the video encoding apparatus **100**.

The receiver **210** receives and parses a bitstream of an encoded video. The image data and encoding information extractor **220** extracts encoded image data for each coding unit from the parsed bitstream, wherein the coding units have a tree structure according to each largest coding unit, and outputs the extracted image data to the image data decoder **230**. The image data and encoding information extractor **220** may extract information about a maximum size of a coding unit of a current picture, from a header about the current picture, a sequence parameter set, or a picture parameter set.

Also, the image data and encoding information extractor **220** extracts, from the parsed bitstream, split information and encoding information about the coding units having a tree structure according to each largest coding unit. The extracted split information and the extracted encoding information are output to the image data decoder **230**. That is, the image data in a bitstream is split into the largest coding unit so that the image data decoder **230** may decode the image data for each largest coding unit.

Split information and encoding information split information according to each largest coding unit and encoding information may be set with respect to at least one split information, and encoding information according to depths may include partition mode information of a corresponding coding unit, prediction mode information, split information of a transformation unit, or the like.

Also, as final depth information, the split information according to depths may be extracted.

The split information and the encoding information according to each of the largest coding units extracted by the image data and encoding information extractor **220** are split information and encoding information determined to generate a minimum encoding error when an encoder, such as the video encoding apparatus **100**, repeatedly performs encoding on each deeper coding unit according to depths according to each largest coding unit. Accordingly, the video decoding apparatus **200** may reconstruct an image by decoding data according to an encoding method that generates the minimum encoding error.

Because the split information and the encoding information according to an embodiment may be assigned to a predetermined data unit from among a corresponding coding unit, a prediction unit, and a minimum unit, the image data

and encoding information extractor **220** may extract the split information and the encoding information according to the predetermined data units. If the split information and the encoding information of a corresponding largest coding unit are recorded according to each of the predetermined data units, predetermined data units having same split information and encoding information may be inferred to be the data units included in the same largest coding unit.

The image data decoder **230** may reconstruct the current picture by decoding the image data in each largest coding unit based on the split information and the encoding information according to the largest coding units. That is, the image data decoder **230** may decode the encoded image data, based on a read partition mode, a prediction mode, and a transformation unit for each coding unit from among the coding units having the tree structure included in each largest coding unit. A decoding process may include a prediction process including intra prediction and motion compensation, and an inverse transformation process.

The image data decoder **230** may perform intra prediction or motion compensation according to a partition and a prediction mode of each coding unit, based on the information about the partition mode and the prediction mode of the prediction unit of the coding unit according to depths.

In addition, for inverse transformation for each largest coding unit, the image data decoder **230** may read information about a transformation unit according to a tree structure for each coding unit so as to perform inverse transformation based on transformation units for each coding unit. Due to the inverse transformation, a pixel value of a spatial domain of the coding unit may be reconstructed.

The image data decoder **230** may determine a final depth of a current largest coding unit by using split information according to depths. If the split information indicates that image data is no longer split in the current depth, the current depth is a final depth. Accordingly, the image data decoder **230** may decode the image data of the current largest coding unit by using the information about the partition mode of the prediction unit, the prediction mode, and the split of the transformation unit for each coding unit corresponding to the current depth.

That is, data units containing the encoding information including the same split information may be gathered by observing the encoding information set assigned for the predetermined data unit from among the coding unit, the prediction unit, and the minimum unit, and the gathered data units may be considered to be one data unit to be decoded by the image data decoder **230** in the same encoding mode. As such, the current coding unit may be decoded by obtaining the information about the encoding mode for each coding unit.

In addition, the video decoding apparatus **200** of FIG. 8 may perform operations of the video decoding apparatuses **20** and **40** described above with reference to FIG. 2A.

FIG. 9 illustrates a concept of coding units, according to various embodiments.

A size of a coding unit may be expressed by width×height, and may be 64×64, 32×32, 16×16, and 8×8. A coding unit of 64×64 may be split into partitions of 64×64, 64×32, 32×64, or 32×32, and a coding unit of 32×32 may be split into partitions of 32×32, 32×16, 16×32, or 16×16, a coding unit of 16×16 may be split into partitions of 16×16, 16×8, 8×16, or 8×8, and a coding unit of 8×8 may be split into partitions of 8×8, 8×4, 4×8, or 4×4.

In video data **310**, a resolution is 1920×1080, a maximum size of a coding unit is 64, and a maximum depth is 2. In video data **320**, a resolution is 1920×1080, a maximum size

of a coding unit is 64, and a maximum depth is 3. In video data **330**, a resolution is 352×288, a maximum size of a coding unit is 16, and a maximum depth is 1. The maximum depth shown in FIG. **19** denotes a total number of splits from a largest coding unit to a smallest coding unit.

If a resolution is high or a data amount is large, it is preferable that a maximum size of a coding unit is large so as to not only increase encoding efficiency but also to accurately reflect characteristics of an image. Accordingly, the maximum size of the coding unit of the video data **310** and **320** having a higher resolution than the video data **330** may be selected to 64.

Since the maximum depth of the video data **310** is 2, coding units **315** of the video data **310** may include a largest coding unit having a long axis size of 64, and coding units having long axis sizes of 32 and 16 since depths are deepened to two layers by splitting the largest coding unit twice. On the other hand, since the maximum depth of the video data **330** is 1, coding units **335** of the video data **330** may include a largest coding unit having a long axis size of 16, and coding units having a long axis size of 8 since depths are deepened to one layer by splitting the largest coding unit once.

Since the maximum depth of the video data **320** is 3, coding units **325** of the video data **320** may include a largest coding unit having a long axis size of 64, and coding units having long axis sizes of 32, 16, and 8 since the depths are deepened to 3 layers by splitting the largest coding unit three times. As a depth deepens, detailed information may be precisely expressed.

FIG. **10** illustrates a block diagram of an image encoder **400** based on coding units, according to various embodiments.

The image encoder **400** according to an embodiment performs operations of a picture encoder **120** of the video encoding apparatus **100** so as to encode image data. That is, an intra predictor **420** performs intra prediction on coding units in an intra mode, from among a current image **405**, per prediction unit, and an inter predictor **415** performs inter prediction on coding units in an inter mode by using the current image **405** and a reference image obtained from a reconstructed picture buffer **410** according to prediction units. The current picture **405** may be split into largest coding units, and then the largest coding units may be sequentially encoded. In this regard, the largest coding unit that is to be split into coding units having a tree structure may be encoded.

Residual data is generated by subtracting prediction data of a coding unit of each mode output from the intra predictor **420** or the inter predictor **415** from data of the current image **405** to be encoded, and the residual data is output as a quantized transformation coefficient through a transformer **425** and a quantizer **430** per transformation unit. The quantized transformation coefficient is reconstructed as the residue data in a spatial domain through an inverse-quantizer **445** and an inverse-transformer **450**. The reconstructed residue data in the spatial domain is added to the prediction data of the coding unit of each mode output from the intra predictor **420** or the inter predictor **415** to be reconstructed as data in a spatial domain of the coding unit of the current image **405**. The reconstructed data in the spatial domain is generated as a reconstructed image through a deblocking unit **455** and an SAO performer **460**. The reconstructed image is stored in the reconstructed picture buffer **410**. Reconstructed images stored in the reconstructed picture buffer **410** may be used as a reference image for inter prediction of another image. The transformation coefficient

quantized by the transformer **425** and the quantizer **430** may be output as a bitstream **440** through an entropy encoder **435**.

In order for the image encoder **400** to be applied in the video encoding apparatus **100**, all elements of the image encoder **400**, i.e., the inter predictor **415**, the intra predictor **420**, the transformer **425**, the quantizer **430**, the entropy encoder **435**, the inverse-quantizer **445**, the inverse-transformer **450**, the deblocking unit **455**, and the SAO performer **460**, may perform operations based on each coding unit among coding units having a tree structure according to each largest coding unit.

In particular, the intra predictor **420** and the inter predictor **415** may determine a partition mode and a prediction mode of each coding unit from among the coding units having a tree structure, by taking into account the maximum size and the maximum depth of a current largest coding unit, and the transformer **425** may determine whether to split a transformation unit according to a quad tree in each coding unit from among the coding units having a tree structure.

FIG. **11** illustrates a block diagram of an image decoder **500** based on coding units, according to various embodiments.

An entropy decoder **515** parses, from a bitstream **505**, encoded image data to be decoded and encoding information required for decoding. The encoded image data corresponds to a quantized transformation coefficient, and an inverse-quantizer **520** and an inverse-transformer **525** reconstruct residue data from the quantized transformation coefficient.

An intra predictor **540** performs intra prediction on a coding unit in an intra mode according to prediction units. An inter predictor **535** performs inter prediction by using a reference image with respect to a coding unit in an inter mode from among a current image, wherein the reference image is obtained by a reconstructed picture buffer **530** according to prediction units.

Prediction data and residue data regarding coding units of each mode, which passed through the intra predictor **540** and the inter predictor **535**, are summed, so that data in a spatial domain regarding coding units of the current image **405** may be reconstructed, and the reconstructed data in the spatial domain may be output as a reconstructed image **560** through a deblocking unit **545** and a sample compensator **550**. Also, reconstructed images that are stored in the reconstructed picture buffer **530** may be output as reference images.

In order for a picture decoder **230** of the video decoding apparatus **200** to decode the image data, operations after the entropy decoder **515** of the image decoder **500** according to an embodiment may be performed.

In order for the image decoder **500** to be applied in the video decoding apparatus **200** according to an embodiment, all elements of the image decoder **500**, i.e., the entropy decoder **515**, the inverse-quantizer **520**, the inverse-transformer **525**, the intra predictor **540**, the inter predictor **535**, the deblocking unit **545**, and the sample compensator **550** may perform operations based on coding units having a tree structure for each largest coding unit.

In particular, the intra predictor **540** and the inter predictor **535** may determine a partition mode and a prediction mode of each coding unit from among the coding units according to a tree structure, and the inverse-transformer **525** may determine whether or not to split a transformation unit according to a quad-tree structure in each coding unit.

FIG. **12** illustrates deeper coding units according to depths, and partitions, according to an embodiment.

The video encoding apparatus **100** according to an embodiment and the video decoding apparatus **200** according to an embodiment use hierarchical coding units so as to consider characteristics of an image. A maximum height, a maximum width, and a maximum depth of coding units may be adaptively determined according to the characteristics of the image, or may be variously set according to user requirements. Sizes of deeper coding units according to depths may be determined according to the predetermined maximum size of the coding unit.

In a hierarchical structure of coding units **600** according to an embodiment, the maximum height and the maximum width of the coding units are each 64, and the maximum depth is 4. In this case, the maximum depth refers to a total number of times the coding unit is split from the largest coding unit to the smallest coding unit. Since a depth deepens along a vertical axis of the hierarchical structure of coding units **600**, a height and a width of the deeper coding unit are each split. Also, a prediction unit and partitions, which are bases for prediction encoding of each deeper coding unit, are shown along a horizontal axis of the hierarchical structure of coding units **600**.

That is, a coding unit **610** is a largest coding unit in the hierarchical structure of coding units **600**, wherein a depth is 0 and a size, i.e., a height by width, is 64×64. The depth deepens along the vertical axis, and a coding unit **620** having a size of 32×32 and a depth of 1, a coding unit **630** having a size of 16×16 and a depth of 2, and a coding unit **640** having a size of 8×8 and a depth of 3 are present. The coding unit **640** having a size of 4×4 and a depth of 3 is a smallest coding unit.

The prediction unit and the partitions of a coding unit are arranged along the horizontal axis according to each depth. That is, if the coding unit **610** having a size of 64×64 and a depth of 0 is a prediction unit, the prediction unit may be split into partitions included in the coding unit **610** having the size of 64×64, i.e. a partition **610** having a size of 64×64, partitions **612** having the size of 64×32, partitions **614** having the size of 32×64, or partitions **616** having the size of 32×32.

Equally, a prediction unit of the coding unit **620** having the size of 32×32 and the depth of 1 may be split into partitions included in the coding unit **620**, i.e. a partition **620** having a size of 32×32, partitions **622** having a size of 32×16, partitions **624** having a size of 16×32, and partitions **626** having a size of 16×16.

Equally, a prediction unit of the coding unit **630** having the size of 16×16 and the depth of 2 may be split into partitions included in the coding unit **630**, i.e. a partition having a size of 16×16 included in the coding unit **630**, partitions **632** having a size of 16×8, partitions **634** having a size of 8×16, and partitions **636** having a size of 8×8.

Equally, a prediction unit of the coding unit **640** having the size of 8×8 and the depth of 3 may be split into partitions included in the coding unit **640**, i.e. a partition **640** having a size of 8×8 included in the coding unit **640**, partitions **642** having a size of 8×4, partitions **644** having a size of 4×8, and partitions **646** having a size of 4×4.

In order to determine a final depth of the largest coding unit **610**, the coding unit determiner **120** of the video encoding apparatus **100** has to perform encoding on coding units respectively corresponding to depths included in the largest coding unit **610**.

The number of deeper coding units according to depths including data in the same range and the same size increases as the depth deepens. For example, four coding units corresponding to a depth of 2 are required to cover data that is

included in one coding unit corresponding to a depth of 1. Accordingly, in order to compare results of encoding the same data according to depths, the data has to be encoded by using each of the coding unit corresponding to the depth of 1 and four coding units corresponding to the depth of 2.

In order to perform encoding according to each of the depths, a minimum encoding error that is a representative encoding error of a corresponding depth may be selected by performing encoding on each of prediction units of the coding units according to depths, along the horizontal axis of the hierarchical structure of coding units **600**. Also, the minimum encoding error may be searched for by comparing representative encoding errors according to depths, by performing encoding for each depth as the depth deepens along the vertical axis of the hierarchical structure of coding units **600**. A depth and a partition generating the minimum encoding error in the largest coding unit **610** may be selected as a final depth and a partition mode of the largest coding unit **610**.

FIG. **13** illustrates a relationship between a coding unit and transformation units, according to an embodiment.

The video encoding apparatus **100** according to an embodiment or the video decoding apparatus **200** according to an embodiment encodes or decodes an image according to coding units having sizes smaller than or equal to a largest coding unit for each largest coding unit. Sizes of transformation units for transformation during an encoding process may be selected based on data units that are not larger than a corresponding coding unit.

For example, in the video encoding apparatus **100** or the video decoding apparatus **200**, when a size of the coding unit **710** is 64×64, transformation may be performed by using the transformation units **720** having a size of 32×32.

Also, data of the coding unit **710** having the size of 64×64 may be encoded by performing the transformation on each of the transformation units having the size of 32×32, 16×16, 8×8, and 4×4, which are smaller than 64×64, and then a transformation unit having the minimum coding error with respect to an original image may be selected.

FIG. **14** illustrates a plurality of pieces of encoding information according to depths, according to an embodiment.

The output unit **130** of the video encoding apparatus **100** according to an embodiment may encode and transmit, as encoding mode information, partition mode information **800**, prediction mode information **810**, and transformation unit size information **820** for each coding unit corresponding to a final depth.

The partition mode information **800** indicates information about a type of a partition obtained by splitting a prediction unit of a current coding unit, wherein the partition is a data unit for prediction encoding the current coding unit. For example, a current coding unit CU_0 having a size of 2N×2N may be split into any one of a partition **802** having a size of 2N×2N, a partition **804** having a size of 2N×N, a partition **806** having a size of N×2N, and a partition **808** having a size of N×N. In this case, the partition mode information **800** about a current coding unit is set to indicate one of the partition **802** having a size of 2N×2N, the partition **804** having a size of 2N×N, the partition **806** having a size of N×2N, and the partition **808** having a size of N×N.

The prediction mode information **810** indicates a prediction mode of each partition. For example, the prediction mode information **810** may indicate a mode of prediction encoding performed on a partition indicated by the partition mode information **800**, i.e., an intra mode **812**, an inter mode **814**, or a skip mode **816**.

The transformation unit size information **820** represents a transformation unit to be based on when transformation is performed on a current coding unit. For example, the transformation unit may be one of a first intra transformation unit **822**, a second intra transformation unit **824**, a first inter transformation unit **826**, and a second intra transformation unit **828**.

The image data and encoding information extractor **220** of the video decoding apparatus **200** may extract and use the partition mode information **800**, the prediction mode information **810**, and the transformation unit size information **820** for each deeper coding unit.

FIG. **15** illustrates deeper coding units according to depths, according to an embodiment.

Split information may be used to represent a change in a depth. The split information indicates whether a coding unit of a current depth is split into coding units of a lower depth.

A prediction unit **910** for prediction encoding a coding unit **900** having a depth of 0 and a size of $2N_0 \times 2N_0$ may include partitions of a partition mode **912** having a size of $2N_0 \times 2N_0$, a partition mode **914** having a size of $2N_0 \times N_0$, a partition mode **916** having a size of $N_0 \times 2N_0$, and a partition mode **918** having a size of $N_0 \times N_0$. Only the partition modes **912**, **914**, **916**, and **918** which are obtained by symmetrically splitting the prediction unit are illustrated, but as described above, a partition mode is not limited thereto and may include asymmetrical partitions, partitions having a predetermined shape, and partitions having a geometrical shape.

According to each partition mode, prediction encoding has to be repeatedly performed on one partition having a size of $2N_0 \times 2N_0$, two partitions having a size of $2N_0 \times N_0$, two partitions having a size of $N_0 \times 2N_0$, and four partitions having a size of $N_0 \times N_0$. The prediction encoding in an intra mode and an inter mode may be performed on the partitions having the sizes of $2N_0 \times 2N_0$, $N_0 \times 2N_0$, $2N_0 \times N_0$, and $N_0 \times N_0$. The prediction encoding in a skip mode may be performed only on the partition having the size of $2N_0 \times 2N_0$.

If an encoding error is smallest in one of the partition modes **912**, **914**, and **916** having the sizes of $2N_0 \times 2N_0$, $2N_0 \times N_0$ and $N_0 \times 2N_0$, the prediction unit **910** may not be split into a lower depth.

If the encoding error is the smallest in the partition mode **918** having the size of $N_0 \times N_0$, a depth is changed from 0 to 1 and split is performed (operation **920**), and encoding may be repeatedly performed on coding units **930** of a partition mode having a depth of 2 and a size of $N_0 \times N_0$ so as to search for a minimum encoding error.

A prediction unit **940** for prediction encoding the coding unit **930** having a depth of 1 and a size of $2N_1 \times 2N_1$ ($=N_0 \times N_0$) may include a partition mode **942** having a size of $2N_1 \times 2N_1$, a partition mode **944** having a size of $2N_1 \times N_1$, a partition mode **946** having a size of $N_1 \times 2N_1$, and a partition mode **948** having a size of $N_1 \times N_1$.

If an encoding error is the smallest in the partition mode **948** having the size of $N_1 \times N_1$, a depth is changed from 1 to 2 and split is performed (in operation **950**), and encoding is repeatedly performed on coding units **960** having a depth of 2 and a size of $N_2 \times N_2$ so as to search for a minimum encoding error.

When a maximum depth is d , deeper coding units according to depths may be set until when a depth corresponds to $d-1$, and split information may be set until when a depth corresponds to $d-2$. That is, when encoding is performed up to when the depth is $d-1$ after a coding unit corresponding to a depth of $d-2$ is split (in operation **970**), a prediction unit

990 for prediction encoding a coding unit **980** having a depth of $d-1$ and a size of $2N_{(d-1)} \times 2N_{(d-1)}$ may include partitions of a partition mode **992** having a size of $2N_{(d-1)} \times 2N_{(d-1)}$, a partition mode **994** having a size of $2N_{(d-1)} \times N_{(d-1)}$, a partition mode **996** having a size of $N_{(d-1)} \times 2N_{(d-1)}$, and a partition mode **998** having a size of $N_{(d-1)} \times N_{(d-1)}$.

Prediction encoding may be repeatedly performed on one partition having a size of $2N_{(d-1)} \times 2N_{(d-1)}$, two partitions having a size of $2N_{(d-1)} \times N_{(d-1)}$, two partitions having a size of $N_{(d-1)} \times 2N_{(d-1)}$, four partitions having a size of $N_{(d-1)} \times N_{(d-1)}$ from among the partition modes so as to search for a partition mode generating a minimum encoding error.

Even when the partition mode **998** having the size of $N_{(d-1)} \times N_{(d-1)}$ has the minimum encoding error, since a maximum depth is d , a coding unit $CU_{(d-1)}$ having a depth of $d-1$ is no longer split into a lower depth, and a depth for the coding units constituting a current largest coding unit **900** is determined to be $d-1$ and a partition mode of the current largest coding unit **900** may be determined to be $N_{(d-1)} \times N_{(d-1)}$. Also, since the maximum depth is d , split information for a coding unit **952** having a depth of $d-1$ is not set.

A data unit **999** may be a 'minimum unit' for the current largest coding unit. A minimum unit according to the embodiment may be a square data unit obtained by splitting a smallest coding unit having a lowermost depth by 4. By performing the encoding repeatedly, the video encoding apparatus **100** according to the embodiment may select a depth generating the minimum encoding error by comparing encoding errors according to depths of the coding unit **900** to determine a depth, and may set a corresponding partition mode and a prediction mode as an encoding mode of the depth.

As such, the minimum encoding errors according to depths are compared in all of the depths of 0, 1, . . . , $d-1$, d , and a depth having a minimum encoding error may be determined as a depth. The depth, the partition mode of the prediction unit, and the prediction mode may be encoded and transmitted as information about the encoding mode. Also, since a coding unit has to be split from a depth of 0 to a depth, only split information of the depth is set to '0', and split information of depths excluding the depth is set to '1'.

The image data and encoding information extractor **220** of the video decoding apparatus **200** according to the embodiment may extract and use a depth and prediction unit information about the coding unit **900** so as to decode the coding unit **912**. The video decoding apparatus **200** according to the embodiment may determine a depth, in which split information is '0', as a depth by using split information according to depths, and may use, for decoding, encoding mode information about the corresponding depth.

FIGS. **16**, **17**, and **18** illustrate a relationship between coding units, prediction units, and transformation units, according to an embodiment.

Coding units **1010** are deeper coding units according to depths determined by the video encoding apparatus **100**, in a largest coding unit. Prediction units **1060** are partitions of prediction units of each of the Coding units **1010** according to depths, and transformation units **1070** are transformation units of each of the coding units according to depths.

When a depth of a largest coding unit is 0 in the deeper coding units **1010**, depths of coding units **1012** and **1054** are 1, depths of coding units **1014**, **1016**, **1018**, **1028**, **1050**, and

1052 are 2, depths of coding units **1020**, **1022**, **1024**, **1026**, **1030**, **1032**, and **1048** are 3, and depths of coding units **1040**, **1042**, **1044**, and **1046** are 4.

Some partitions **1014**, **1016**, **1022**, **1032**, **1048**, **1050**, **1052**, and **1054** from among the prediction units **1060** are obtained by splitting the coding unit. That is, partitions **1014**, **1022**, **1050**, and **1054** are a partition mode having a size of $2N \times N$, partitions **1016**, **1048**, and **1052** are a partition mode having a size of $N \times 2N$, and a partition **1032** is a partition mode having a size of $N \times N$. Prediction units and partitions of the deeper coding units **1010** are smaller than or equal to each coding unit.

Transformation or inverse transformation is performed on image data of the coding unit **1052** in the transformation units **1070** in a data unit that is smaller than the coding unit **1052**. Also, the coding units **1014**, **1016**, **1022**, **1032**, **1048**, **1050**, **1052**, and **1054** in the transformation units **1760** are data units different from those in the Prediction units **1060** in terms of sizes and shapes. That is, the video encoding apparatus **100** and the video decoding apparatus **200** according to the embodiments may perform intra prediction/motion estimation/motion compensation/and transformation/inverse transformation on an individual data unit in the same coding unit.

Accordingly, encoding is recursively performed on each of coding units having a hierarchical structure in each region of a largest coding unit so as to determine an optimum coding unit, and thus coding units according to a recursive tree structure may be obtained. Encoding information may include split information about a coding unit, partition mode information, prediction mode information, and transformation unit size information. Table 1 below shows the encoding information that may be set by the video encoding apparatus **100** and the video decoding apparatus **200** according to the embodiments.

TABLE 1

Split Information 0 (Encoding on Coding Unit having Size of $2N \times 2N$ and Current Depth of d)					
Prediction Mode	Partition Type		Size of Transformation Unit		Split Information 1
Intra	Symmetrical	Asymmetrical	Split	Split	Repeatedly
Inter	Partition Type	Partition Type	Information 0 of Transformation Unit	Information 1 of Transformation Unit	of Encode Coding Units having Lower Depth of d + 1
Skip (Only $2N \times 2N$)	$2N \times 2N$	$2N \times nU$	$2N \times 2N$	$N \times N$	
	$2N \times N$	$2N \times nD$		(Symmetrical Partition Type)	
	$N \times 2N$	$nL \times 2N$		$N/2 \times N/2$	
	$N \times N$	$nR \times 2N$		(Asymmetrical Partition Type)	

The output unit **130** of the video encoding apparatus **100** according to the embodiment may output the encoding information about the coding units having a tree structure, and the image data and encoding information extractor **220** of the video decoding apparatus **200** according to the embodiment may extract the encoding information about the coding units having a tree structure from a received bit-stream.

Split information indicates whether a current coding unit is split into coding units of a lower depth. If split information of a current depth d is 0, a depth, in which a current coding unit is no longer split into a lower depth, is a final depth, and thus partition mode information, prediction mode information, and transformation unit size information may be

defined for the final depth. If the current coding unit has to be further split according to the split information, encoding has to be independently performed on each of four split coding units of a lower depth.

A prediction mode may be one of an intra mode, an inter mode, and a skip mode. The intra mode and the inter mode may be defined in all partition modes, and the skip mode may be defined only in a partition mode having a size of $2N \times 2N$.

The partition mode information may indicate symmetrical partition modes having sizes of $2N \times 2N$, $2N \times N$, $N \times 2N$, and $N \times N$, which are obtained by symmetrically splitting a height or a width of a prediction unit, and asymmetrical partition modes having sizes of $2N \times nU$, $2N \times nD$, $nL \times 2N$, and $nR \times 2N$, which are obtained by asymmetrically splitting the height or width of the prediction unit. The asymmetrical partition modes having the sizes of $2N \times nU$ and $2N \times nD$ may be respectively obtained by splitting the height of the prediction unit in 1:3 and 3:1, and the asymmetrical partition modes having the sizes of $nL \times 2N$ and $nR \times 2N$ may be respectively obtained by splitting the width of the prediction unit in 1:3 and 3:1.

The size of the transformation unit may be set to be two types in the intra mode and two types in the inter mode. That is, if split information of the transformation unit is 0, the size of the transformation unit may be $2N \times 2N$, which is the size of the current coding unit. If split information of the transformation unit is 1, the transformation units may be obtained by splitting the current coding unit. Also, if a partition mode of the current coding unit having the size of $2N \times 2N$ is a symmetrical partition mode, a size of a transformation unit may be $N \times N$, and if the partition mode of the current coding unit is an asymmetrical partition mode, the size of the transformation unit may be $N/2 \times N/2$.

The encoding information about coding units having a tree structure according to the embodiment may be assigned to at least one of a coding unit corresponding to a depth, a prediction unit, and a minimum unit. The coding unit corresponding to the depth may include at least one of a prediction unit and a minimum unit containing the same encoding information.

Accordingly, it is determined whether adjacent data units are included in the coding unit corresponding to the same depth by comparing a plurality of pieces of encoding information of the adjacent data units. Also, a corresponding coding unit corresponding to a depth is determined by using encoding information of a data unit, and thus a distribution of depths in a largest coding unit may be inferred.

Accordingly, if a current coding unit is predicted based on adjacent data units, encoding information of data units in deeper coding units adjacent to the current coding unit may be directly referred to and used.

In another embodiment, if a current coding unit is prediction-encoded based on adjacent data units, the adjacent data units may be referred to in a manner that data adjacent to the current coding unit is searched for in deeper coding units by using encoding information of the deeper coding units adjacent to the current coding unit.

FIG. 19 illustrates a relationship between a coding unit, a prediction unit, and a transformation unit, according to encoding mode information of Table 1.

A largest coding unit **1300** includes coding units **1302**, **1304**, **1306**, **1312**, **1314**, **1316**, and **1318** of depths. Here, since the coding unit **1318** is a coding unit of a depth, split information may be set to 0. Partition mode information of the coding unit **1318** having a size of $2N \times 2N$ may be set to be one of partition modes including $2N \times 2N$ **1322**, $2N \times N$ **1324**, $N \times 2N$ **1326**, $N \times N$ **1328**, $2N \times nU$ **1332**, $2N \times nD$ **1334**, $nL \times 2N$ **1336**, and $nR \times 2N$ **1338**.

Transformation unit split information (TU size flag) is a type of a transformation index, and a size of a transformation unit corresponding to the transformation index may be changed according to a prediction unit type or partition mode of the coding unit.

For example, when the partition mode information is set to be one of symmetrical partition modes $2N \times 2N$ **1322**, $2N \times N$ **1324**, $N \times 2N$ **1326**, and $N \times N$ **1328**, if the transformation unit split information is 0, a transformation unit **1342** having a size of $2N \times 2N$ is set, and if the transformation unit split information is 1, a transformation unit **1344** having a size of $N \times N$ may be set.

When the partition mode information is set to be one of asymmetrical partition modes $2N \times nU$ **1332**, $2N \times nD$ **1334**, $nL \times 2N$ **1336**, and $nR \times 2N$ **1338**, if the transformation unit split information (TU size flag) is 0, a transformation unit **1352** having a size of $2N \times 2N$ may be set, and if the transformation unit split information is 1, a transformation unit **1354** having a size of $N/2 \times N/2$ may be set.

The transformation unit split information (TU size flag) described above with reference to FIG. 12 is a flag having a value of 0 or 1, but the transformation unit split information according to an embodiment is not limited to a flag having 1 bit, and the transformation unit may be hierarchically split while the transformation unit split information increases in a manner of 0, 1, 2, 3 . . . etc., according to setting. The transformation unit split information may be an example of the transformation index.

In this case, the size of a transformation unit that has been actually used may be expressed by using the transformation unit split information according to the embodiment, together with a maximum size of the transformation unit and a minimum size of the transformation unit. The video encoding apparatus **100** according to the embodiment may encode maximum transformation unit size information, minimum transformation unit size information, and maximum transformation unit split information. The result of encoding the maximum transformation unit size information, the minimum transformation unit size information, and the maximum transformation unit split information may be inserted into an SPS. The video decoding apparatus **200** according to the embodiment may decode video by using the maximum transformation unit size information, the minimum transformation unit size information, and the maximum transformation unit split information.

For example, (a) if the size of a current coding unit is 64×64 and a maximum transformation unit size is 32×32 , (a-1) then the size of a transformation unit may be 32×32 when a TU size flag is 0, (a-2) may be 16×16 when the TU size flag is 1, and (a-3) may be 8×8 when the TU size flag is 2.

As another example, (b) if the size of the current coding unit is 32×32 and a minimum transformation unit size is 32×32 , (b-1) then the size of the transformation unit may be 32×32 when the TU size flag is 0. Here, the TU size flag cannot be set to a value other than 0, since the size of the transformation unit cannot be less than 32×32 .

As another example, (c) if the size of the current coding unit is 64×64 and a maximum TU size flag is 1, then the TU size flag may be 0 or 1. Here, the TU size flag cannot be set to a value other than 0 or 1.

Thus, if it is defined that the maximum TU size flag is 'MaxTransformSizeIndex', a minimum transformation unit size is 'MinTransformSize', and a transformation unit size is 'RootTuSize' when the TU size flag is 0, then a current minimum transformation unit size 'CurrMinTuSize' that can be determined in a current coding unit may be defined by Equation (1):

$$\text{CurrMinTuSize} = \max(\text{MinTransformSize}, \text{RootTuSize} / (2^{\text{MaxTransformSizeIndex}})) \quad (1)$$

Compared to the current minimum transformation unit size 'CurrMinTuSize' that can be determined in the current coding unit, a transformation unit size 'RootTuSize' when the TU size flag is 0 may denote a maximum transformation unit size that can be selected in the system. In Equation (1), 'RootTuSize/(2^{MaxTransformSizeIndex})' denotes a transformation unit size when the transformation unit size 'RootTuSize', when the TU size flag is 0, is split by the number of times corresponding to the maximum TU size flag, and 'MinTransformSize' denotes a minimum transformation size. Thus, a smaller value from among 'RootTuSize/(2^{MaxTransformSizeIndex})' and 'MinTransformSize' may be the current minimum transformation unit size 'CurrMinTuSize' that can be determined in the current coding unit.

According to an embodiment, the maximum transformation unit size RootTuSize may vary according to the type of a prediction mode.

For example, if a current prediction mode is an inter mode, then 'RootTuSize' may be determined by using Equation (2) below. In Equation (2), 'MaxTransformSize' denotes a maximum transformation unit size, and 'PUSize' denotes a current prediction unit size.

$$\text{RootTuSize} = \min(\text{MaxTransformSize}, \text{PUSize}) \quad (2)$$

That is, if the current prediction mode is the inter mode, the transformation unit size 'RootTuSize', when the TU size flag is 0, may be a smaller value from among the maximum transformation unit size and the current prediction unit size.

If a prediction mode of a current partition unit is an intra mode, 'RootTuSize' may be determined by using Equation (3) below. 'PartitionSize' denotes the size of the current partition unit.

$$\text{RootTuSize} = \min(\text{MaxTransformSize}, \text{PartitionSize}) \quad (3)$$

That is, if the current prediction mode is the intra mode, the transformation unit size 'RootTuSize' when the TU size flag is 0 may be a smaller value from among the maximum transformation unit size and the size of the current partition unit.

However, the current maximum transformation unit size 'RootTuSize' that varies according to the type of a predic-

tion mode in a partition unit is just an embodiment, and a factor for determining the current maximum transformation unit size is not limited thereto.

According to the video encoding method based on coding units of a tree structure described above with reference to FIGS. 7 through 19, image data of a spatial domain is encoded in each of the coding units of the tree structure, and the image data of the spatial domain is reconstructed in a manner that decoding is performed on each largest coding unit according to the video decoding method based on the coding units of the tree structure, so that a video that is formed of pictures and picture sequences may be reconstructed. The reconstructed video may be reproduced by a reproducing apparatus, may be stored in a storage medium, or may be transmitted via a network.

Also, offset parameters may be signaled with respect to each picture, each slice, each largest coding unit, each of coding units of a tree structure, each prediction unit of the coding units, or each transformation unit of the coding units. For example, values of reconstructed pixels of each largest coding unit may be adjusted by using offset values reconstructed based on received offset parameters, and thus a largest coding unit having a minimum error between an original block and the largest coding unit may be reconstructed.

For convenience of description, the video encoding methods described above with reference to FIGS. 1A through 18 are collectively referred to as 'video encoding method'. In addition, the video decoding methods described above with reference to FIGS. 1A through 18 are referred to as 'video decoding method'.

Also, a video encoding apparatus including the video encoding apparatus 10, the video encoding apparatus 100, or the image encoder 400, which has been described with reference to FIGS. 1A through 18, will be collectively referred to as a 'video encoding apparatus'. Also, a video decoding apparatus including the video decoding apparatus 20, the video decoding apparatus 200, or the image decoder 500 which are described with reference to FIGS. 2A through 19 will be collectively referred to as a 'video decoding apparatus'.

A computer-readable recording medium such as a disc 26000 that stores the programs according to an embodiment will now be described in detail.

FIG. 20 illustrates a physical structure of the disc 26000 in which a program is stored, according to an embodiment. The disc 26000, which is a storage medium, may be a hard drive, a compact disc-read only memory (CD-ROM) disc, a Blu-ray disc, or a digital versatile disc (DVD). The disc 26000 includes a plurality of concentric tracks Tr that are each divided into a specific number of sectors Se in a circumferential direction of the disc 26000. In a specific region of the disc 26000, a program that executes the quantized parameter determining method, the video encoding method, and the video decoding method described above may be assigned and stored.

A computer system embodied using a storage medium that stores a program for executing the video encoding method and the video decoding method as described above will now be described with reference to FIG. 21.

FIG. 21 illustrates a disc drive 26800 for recording and reading a program by using the disc 26000. A computer system 27000 may store a program that executes at least one of a video encoding method and a video decoding method, in the disc 26000 via the disc drive 26800. In order to run the program stored in the disc 26000 in the computer system

26700, the program may be read from the disc 26000 and may be transmitted to the computer system 26700 by using the disc drive 26800.

The program that executes at least one of the video encoding method and the video decoding method may be stored not only in the disc 26000 illustrated in FIGS. 20 and 21 but may also be stored in a memory card, a ROM cassette, or a solid state drive (SSD).

A system to which the video encoding method and the video decoding method according to the embodiments described above are applied will be described below.

FIG. 22 illustrates an overall structure of a content supply system 11000 for providing a content distribution service. A service area of a communication system is divided into predetermined-sized cells, and wireless base stations 11700, 11800, 11900, and 12000 are installed in these cells, respectively.

The content supply system 11000 includes a plurality of independent devices. For example, the plurality of independent devices, such as a computer 12100, a personal digital assistant (PDA) 12200, a video camera 12300, and a mobile phone 12500, are connected to the Internet 11100 via an internet service provider 11200, a communication network 11400, and the wireless base stations 11700, 11800, 11900, and 12000.

However, the content supply system 11000 is not limited to the structure as illustrated in FIG. 16 (22?), and devices may be selectively connected thereto. The plurality of independent devices may be directly connected to the communication network 11400, not via the wireless base stations 11700, 11800, 11900, and 12000.

The video camera 12300 is an imaging device, e.g., a digital video camera, which is capable of capturing video images. The mobile phone 12500 may employ at least one communication method from among various protocols, e.g., Personal Digital Communications (PDC), Code Division Multiple Access (CDMA), Wideband-Code Division Multiple Access (W-CDMA), Global System for Mobile Communications (GSM), and Personal Handyphone System (PHS).

The video camera 12300 may be connected to a streaming server 11300 via the wireless base station 11900 and the communication network 11400. The streaming server 11300 allows content received from a user via the video camera 12300 to be streamed via a real-time broadcast. The content received from the video camera 12300 may be encoded by the video camera 12300 or the streaming server 11300. Video data captured by the video camera 12300 may be transmitted to the streaming server 11300 via the computer 12100.

Video data captured by a camera 12600 may also be transmitted to the streaming server 11300 via the computer 12100. The camera 12600 such as a digital camera is an imaging device capable of capturing both still images and video images. The video data captured by the camera 12600 may be encoded by using the camera 12600 or the computer 12100. Software that performs encoding and decoding video may be stored in a computer-readable recording medium, e.g., a CD-ROM disc, a floppy disc, a hard disc drive, an SSD, or a memory card, which may be accessed by the computer 12100.

If video data is captured by a camera built in the mobile phone 12500, the video data may be received from the mobile phone 12500.

The video data may also be encoded by a large scale integrated circuit (LSI) system installed in the video camera 12300, the mobile phone 12500, or the camera 12600.

In the content supply system **11000** according to an embodiment, content data, e.g., content recorded during a concert, which has been recorded by a user using the video camera **12300**, the camera **12600**, the mobile phone **12500**, or another imaging device is encoded and is transmitted to the streaming server **11300**. The streaming server **11300** may transmit the encoded content data in a type of a streaming content to other clients that request the content data.

The clients are devices capable of decoding the encoded content data, e.g., the computer **12100**, the PDA **12200**, the video camera **12300**, or the mobile phone **12500**. Thus, the content supply system **11000** allows the clients to receive and reproduce the encoded content data. Also, the content supply system **11000** allows the clients to receive the encoded content data and to decode and reproduce the encoded content data in real-time, thereby enabling personal broadcasting.

The video encoding apparatus and the video decoding apparatus may be applied to encoding and decoding operations of the plurality of independent devices included in the content supply system **11000**.

With reference to FIGS. **23** and **24**, the mobile phone **12500** included in the content supply system **11000** according to an embodiment will now be described in detail.

FIG. **23** illustrates an external structure of the mobile phone **12500** to which the video encoding method and the video decoding method are applied, according to an embodiment. The mobile phone **12500** may be a smart phone, the functions of which are not limited and a large number of the functions of which may be changed or expanded.

The mobile phone **12500** includes an internal antenna **12510** via which a radio-frequency (RF) signal may be exchanged with the wireless base station **12000**, and includes a display screen **12520** for displaying images captured by a camera **12530** or images that are received via the antenna **12510** and decoded, e.g., a liquid crystal display (LCD) or an organic light-emitting diode (OLED) screen. The mobile phone **12500** includes an operation panel **12540** including a control button and a touch panel. If the display screen **12520** is a touch screen, the operation panel **12540** further includes a touch sensing panel of the display screen **12520**. The mobile phone **12500** includes a speaker **12580** for outputting voice and sound or another type of a sound output unit, and a microphone **12550** for inputting voice and sound or another type of a sound input unit. The mobile phone **12500** further includes the camera **12530**, such as a charge-coupled device (CCD) camera, to capture video and still images. The mobile phone **12500** may further include a storage medium **12570** for storing encoded/decoded data, e.g., video or still images captured by the camera **12530**, received via email, or obtained according to various ways; and a slot **12560** via which the storage medium **12570** is loaded into the mobile phone **12500**. The storage medium **12570** may be a flash memory, e.g., a secure digital (SD) card or an electrically erasable and programmable read only memory (EEPROM) included in a plastic case.

FIG. **24** illustrates an internal structure of the mobile phone **12500**. In order to systemically control parts of the mobile phone **12500** including the display screen **12520** and the operation panel **12540**, a power supply circuit **12700**, an operation input controller **12640**, an image encoder **12720**, a camera interface **12630**, an LCD controller **12620**, an image decoder **12690**, a multiplexer/demultiplexer **12680**, a recording/reading unit **12670**, a modulation/demodulation unit **12660**, and a sound processor **12650** are connected to a central controller **12710** via a synchronization bus **12730**.

If a user operates a power button and sets from a 'power off' state to a 'power on' state, the power supply circuit **12700** supplies power to all the parts of the mobile phone **12500** from a battery pack, thereby setting the mobile phone **12500** to an operation mode.

The central controller **12710** includes a central processing unit (CPU), a read-only memory (ROM), and a random access memory (RAM).

While the mobile phone **12500** transmits communication data to the outside, a digital signal is generated by the mobile phone **12500** under control of the central controller **12710**. For example, the sound processor **12650** may generate a digital sound signal, the image encoder **12720** may generate a digital image signal, and text data of a message may be generated via the operation panel **12540** and the operation input controller **12640**. When a digital signal is transmitted to the modulation/demodulation unit **12660** by the control of the central controller **12710**, the modulation/demodulation unit **12660** modulates a frequency band of the digital signal, and a communication circuit **12610** performs digital-to-analog conversion (DAC) and frequency conversion on the frequency band-modulated digital sound signal.

A transmission signal output from the communication circuit **12610** may be transmitted to a voice communication base station or the wireless base station **12000** via the antenna **12510**.

For example, when the mobile phone **12500** is in a conversation mode, a sound signal obtained via the microphone **12550** is converted to a digital sound signal by the sound processor **12650** by the control of the central controller **12710**. The generated digital sound signal may be converted to a transmission signal through the modulation/demodulation unit **12660** and the communication circuit **12610**, and may be transmitted via the antenna **12510**.

When a text message, e.g., email, is transmitted in a data communication mode, text data of the text message is input via the operation panel **12540** and is transmitted to the central controller **12610** via the operation input controller **12640**. By the control of the central controller **12610**, the text data is transformed into a transmission signal via the modulation/demodulation unit **12660** and the communication circuit **12610** and is transmitted to the wireless base station **12000** via the antenna **12510**.

In order to transmit image data in the data communication mode, image data captured by the camera **12530** is provided to the image encoder **12720** via the camera interface **12630**. The image data captured by the camera **12530** may be directly displayed on the display screen **12520** via the camera interface **12630** and the LCD controller **12620**.

A structure of the image encoder **12720** may correspond to that of the video encoding apparatus described above. The image encoder **12720** may transform the image data received from the camera **12530** into compressed and encoded image data according to the aforementioned video encoding method, and then output the encoded image data to the multiplexer/demultiplexer **12680**.

During a recording operation of the camera **12530**, a sound signal obtained by the microphone **12550** of the mobile phone **12500** may be transformed into digital sound data via the sound processor **12650**, and the digital sound data may be transmitted to the multiplexer/demultiplexer **12680**.

The multiplexer/demultiplexer **12680** multiplexes the encoded image data received from the image encoder **12720**, together with the sound data received from the sound processor **12650**. A result of multiplexing the data may be transformed into a transmission signal via the modulation/

demodulation unit **12660** and the communication circuit **12610**, and may then be transmitted via the antenna **12510**.

While the mobile phone **12500** receives communication data from the outside, frequency recovery and analog-to-digital conversion (ADC) are performed on a signal received via the antenna **12510** so as to convert the received signal into a digital signal. The modulation/demodulation unit **12660** modulates a frequency band of the digital signal. The frequency-band modulated digital signal is transmitted to the video decoder **12690**, the sound processor **12650**, or the LCD controller **12620**, according to the type of the digital signal.

In the conversation mode, the mobile phone **12500** amplifies a signal received via the antenna **12510**, and obtains a digital sound signal by performing frequency conversion and ADC on the amplified signal. A received digital sound signal is converted to an analog sound signal via the modulation/demodulation unit **12660** and the sound processor **12650**, and the analog sound signal is output via the speaker **12580** by the control of the central controller **12710**.

When, in the data communication mode, data of a video file accessed at an Internet website is received, a signal received from the wireless base station **12000** via the antenna **12510** is output as multiplexed data via the modulation/demodulation unit **12660**, and the multiplexed data is transmitted to the multiplexer/demultiplexer **12680**.

In order to decode the multiplexed data received via the antenna **12510**, the multiplexer/demultiplexer **12680** demultiplexes the multiplexed data into an encoded video data stream and an encoded audio data stream. Via the synchronization bus **12730**, the encoded video data stream and the encoded audio data stream are provided to the video decoder **12690** and the sound processor **12650**, respectively.

A structure of the image decoder **12690** may correspond to that of the video decoding apparatus described above. The image decoder **12690** may decode the encoded video data to obtain reconstructed video data and provide the reconstructed video data to the display screen **12520** via the LCD controller **12620**, by using the aforementioned video decoding method.

Thus, the data of the video file accessed at the Internet website may be displayed on the display screen **12520**. At the same time, the sound processor **12650** may transform audio data into an analog sound signal, and provide the analog sound signal to the speaker **12580**. Thus, audio data contained in the video file accessed at the Internet website may also be reproduced via the speaker **12580**.

The mobile phone **12500** or a communication terminal in a different form may be a transceiving terminal including both a video encoding apparatus and a video decoding apparatus, a transmitting terminal including only the aforementioned video encoding apparatus, or a receiving terminal including only the video decoding apparatus.

A communication system is not limited to the communication system described above with reference to FIG. **23**. For example, FIG. **25** illustrates a digital broadcasting system employing a communication system, according to an embodiment. The digital broadcasting system of FIG. **25** according to an embodiment may receive a digital broadcast transmitted via a satellite or a terrestrial network by using the video encoding apparatus and the video decoding apparatus.

In more detail, a broadcasting station **12890** transmits a video data stream to a communication satellite or a broadcasting satellite **12900** by using radio waves. The broadcasting satellite **12900** transmits a broadcast signal, and the broadcast signal is transmitted to a satellite broadcast

receiver via a household antenna **12860**. In every house, an encoded video stream may be decoded and reproduced by a TV receiver **12810**, a set-top box **12870**, or another device.

When the video decoding apparatus is implemented in a reproducing apparatus **12830**, the reproducing apparatus **12830** may parse and decode an encoded video stream recorded on a storage medium **12820**, such as a disc or a memory card to reconstruct digital signals. Thus, the reconstructed video signal may be reproduced, for example, on a monitor **12840**.

In the set-top box **12870** connected to the antenna **12860** for a satellite/terrestrial broadcast or a cable antenna **12850** for receiving a cable television (TV) broadcast, the video decoding apparatus may be installed. Data output from the set-top box **12870** may also be reproduced on a TV monitor **12880**.

As another example, the video decoding apparatus may be installed in the TV receiver **12810** instead of the set-top box **12870**.

An automobile **12920** that has an appropriate antenna **12910** may receive a signal transmitted from the satellite **12900** or the wireless base station **11700**. A decoded video may be reproduced on a display screen of an automobile navigation system **12930** installed in the automobile **12920**.

A video signal may be encoded by the video encoding apparatus and may then be recorded to and stored in a storage medium. In more detail, an image signal may be stored in a DVD disc **12960** by a DVD recorder or may be stored in a hard disc by a hard disc recorder **12950**. As another example, the video signal may be stored in an SD card **12970**. If the hard disc recorder **12950** includes the video decoding apparatus according to the embodiment, a video signal recorded on the DVD disc **12960**, the SD card **12970**, or another storage medium may be reproduced on the TV monitor **12880**.

The automobile navigation system **12930** may not include the camera **12530**, the camera interface **12630**, and the image encoder **12720** of FIG. **25**. For example, the computer **12100** and the TV receiver **12810** may not include the camera **12530**, the camera interface **12630**, and the image encoder **12720** of FIG. **25**.

FIG. **26** illustrates a network structure of a cloud computing system using a video encoding apparatus and a video decoding apparatus, according to an embodiment.

The cloud computing system may include a cloud computing server **14100**, a user database (DB) **14100**, a plurality of computing resources **14200**, and a user terminal.

The cloud computing system provides an on-demand outsourcing service of the plurality of computing resources **14200** via a data communication network, e.g., the Internet, in response to a request from the user terminal. Under a cloud computing environment, a service provider provides users with desired services by combining computing resources at data centers located at physically different locations by using virtualization technology. A service user does not have to install computing resources, e.g., an application, a storage, an operating system (OS), and security software, into his/her own terminal in order to use them, but may select and use desired services from among services in a virtual space generated through the virtualization technology, at a desired point in time.

A user terminal of a specified service user is connected to the cloud computing server **14000** via a data communication network including the Internet and a mobile telecommunication network. User terminals may be provided cloud computing services, and particularly video reproduction services, from the cloud computing server **14000**. The user

terminals may be various types of electronic devices capable of being connected to the Internet, e.g., a desktop PC **14300**, a smart TV **14400**, a smart phone **14500**, a notebook computer **14600**, a portable multimedia player (PMP) **14700**, a tablet PC **14100**, and the like.

The cloud computing server **14100** may combine the plurality of computing resources **14200** distributed in a cloud network and provide user terminals with a result of combining. The plurality of computing resources **14200** may include various data services, and may include data uploaded from user terminals. As described above, the cloud computing server **14100** may provide user terminals with desired services by combining video database distributed in different regions according to the virtualization technology.

User information about users who have subscribed for a cloud computing service is stored in the user DB **14100**. The user information may include logging information, addresses, names, and personal credit information of the users. The user information may further include indexes of videos. Here, the indexes may include a list of videos that have already been reproduced, a list of videos that are being reproduced, a pausing point of a video that was being reproduced, and the like.

Information about a video stored in the user DB **14100** may be shared between user devices. For example, when a video service is provided to the notebook computer **14600** in response to a request from the notebook computer **14600**, a reproduction history of the video service is stored in the user DB **14100**. When a request to reproduce the video service is received from the smart phone **14500**, the cloud computing server **14000** searches for and reproduces the video service, based on the user DB **14100**. When the smart phone **14500** receives a video data stream from the cloud computing server **14000**, a process of reproducing video by decoding the video data stream is similar to an operation of the mobile phone **12500** described above with reference to FIG. **23**.

The cloud computing server **14000** may refer to a reproduction history of a desired video service, stored in the user DB **14100**. For example, the cloud computing server **14000** receives a request to reproduce a video stored in the user DB **14100**, from a user terminal. If this video was being reproduced, then a method of streaming this video, performed by the cloud computing server **14000**, may vary according to the request from the user terminal, i.e., according to whether the video will be reproduced, starting from a start thereof or a pausing point thereof. For example, if the user terminal requests to reproduce the video, starting from the start thereof, the cloud computing server **14000** transmits streaming data of the video starting from a first frame thereof to the user terminal. If the user terminal requests to reproduce the video, starting from the pausing point thereof, the cloud computing server **14000** transmits streaming data of the video starting from a frame corresponding to the pausing point, to the user terminal.

In this case, the user terminal may include the video decoding apparatus as described above with reference to FIGS. **1A** through **26**. As another example, the user terminal may include the video encoding apparatus as described above with reference to FIGS. **1A** through **26**. Alternatively, the user terminal may include both the video decoding apparatus and the video encoding apparatus as described above with reference to FIGS. **1A** through **26**.

Various applications of a video encoding method, a video decoding method, a video encoding apparatus, and a video decoding apparatus according to various embodiments described above with reference to FIGS. **1A** through **26** have been described above with reference to FIGS. **13** through **19**.

However, various embodiments of methods of storing the video encoding method and the video decoding method in a storage medium or various embodiments of methods of implementing the video encoding apparatus and the video decoding apparatus in a device described above with reference to FIGS. **1A** through **19** are not limited to the embodiments of FIGS. **20** through **26**.

Throughout the specification, the description "A may include one of a1, a2, and a3" may mean that an exemplary element that may be included in an A element may be a1, a2, or a3.

However, the element that may be included in the A element is not limited to a1, a2, or a3 due to the description. Thus, the element that may be included in the A element should not be exclusively construed as being limited to a1, a2, and a3 excluding other elements that are not specified herein.

The description means that the A element may include a1, may include a2, or may include a3. The description does not mean that elements included in the A element should be selectively determined from a predetermined group. For example, the description should not be construed as being limited to that a1, a2, or a3 selected from a group necessarily including a1, a2, and a3 configures an A component.

Throughout the specification, the description "at least one of a1, a2, and/or a3" indicates one of "a1", "a2", "a3", "a1 and a2", "a1 and a3", "a2 and a3", and "a1, a2 and a3".

Therefore, the description should not be construed as being limited to that the description "at least one of a1, a2, and/or a3" means "at least one of a1", "at least one of a2", and/or "at least one of a3", unless there is a particular description "at least one of a1, at least one of a2, and/or at least one of a3".

The one or more embodiments may be written as computer programs and may be implemented in general-use digital computers that execute the programs by using a computer-readable recording medium. Examples of the computer-readable recording medium include magnetic storage media (e.g., ROM, floppy disks, hard disks, etc.), optical recording media (e.g., CD-ROMs, or DVDs), etc.

While this disclosure has been particularly shown and described with reference to embodiments thereof, it will be understood by those of ordinary skill in the art that various changes in form and details may be made therein without departing from the spirit and scope of the disclosure. The embodiments should be considered in a descriptive sense only and not for purposes of limitation. The scope of the disclosure is defined not by the detailed description of the disclosure but by the appended claims, and all differences within the scope will be construed as being included in the present disclosure.

The invention claimed is:

1. A video decoding method comprising:

obtaining a residue of a first sampling rate regarding a current block by decoding a bitstream;

when the current block is intra predicted, generating a prediction block of the current block of the first sampling rate which is same as the first sampling rate of the residue by using a block that is previously decoded at the first sampling rate and then stored in a buffer;

when the current block is inter predicted, generating a prediction block of a second sampling rate, which is different from the first sampling rate of the residue, by using an image previously decoded at the second sampling rate which is changed from at least one block of the first sampling rate comprised in the image previously decoded, wherein the at least one block of

61

the first sampling rate is based on another residue of the first sampling rate, and wherein the another residue of the first sampling rate is obtained from the bitstream and is related to the image previously decoded, and then generating the prediction block of the current block of the first sampling rate which is same as the first sampling rate of the residue by changing the generated prediction block of the second sampling rate to the prediction block of the first sampling rate; and
 5
 generating a reconstruction block of the first sampling rate by using the prediction block of the first sampling rate and the residue of the first sampling rate,
 10
 wherein the first sampling rate is higher than the second sampling rate.

2. The video decoding method of claim 1, further comprising storing the reconstruction block of the first sampling rate in the buffer. 15

3. The video decoding method of claim 1, further comprising, when a block to be decoded after the current block is intra predicted, generating a prediction block of the block to be decoded after the current block by using the reconstruction block of the first sampling rate. 20

4. The video decoding method of claim 1, wherein in the generating, when the current block is intra predicted, of the prediction block of the current block by using the block that is previously decoded at the first sampling rate and then is stored in the buffer, 25
 a reference pixel, which is from among pixels comprised in the current block and is to be used in intra predicting a block to be decoded after the current block, is predicted by using the block that is previously decoded at the first sampling rate and then is stored in the buffer, other pixels excluding the reference pixel which are comprised in the current block are predicted by using a block of the second sampling rate which is previously decoded and then is stored in the buffer, and 30
 the block of the second sampling rate is generated by changing the block that is previously decoded at the first sampling rate to the second sampling rate.

5. A non-transitory computer readable recording medium having recorded thereon a program for executing the method of claim 1. 35
 40

6. A video decoding apparatus comprising:
 a buffer configured to store a block to be used in intra prediction; and 45
 a decoder configured to:
 obtain a residue of a first sampling rate regarding a current block by decoding a bitstream,
 when the current block is intra predicted, generate a prediction block of the current block of the first sampling rate which is same as the first sampling rate of the residue by using a block that is previously decoded at the first sampling rate and then is stored in the buffer, and 50
 and

62

when the current block is inter predicted, generate a prediction block of a second sampling rate which is different from the first sampling rate of the residue, by using an image previously decoded at the second sampling rate which is changed from at least one block of the first sampling rate comprised in the image previously decoded, wherein the at least one block of the first sampling rate is based on another residue of the first sampling rate, and wherein the another residue of the first sampling rate is obtained from the bitstream and is related to the image previously decoded, and generate the prediction of the current block of the first sampling rate which is same as the first sampling rate of the residue by changing the generated prediction block of the second sampling rate to the prediction block of the first sampling rate,
 generate a reconstruction block of the first sampling rate by using the prediction block and the residue of the first sampling rate,
 wherein the first sampling rate is higher than the second sampling rate.

7. A video encoding method comprising:
 when a current block is intra predicted, generating a prediction block of the current block of a first sampling rate which is same as a sampling rate of a residue by using a block that is previously decoded at the first sampling rate and then is stored in a buffer;
 when the current block is inter predicted, generating a prediction block of a second sampling rate which is different from the first sampling rate of the residue, by using an image previously decoded at the second sampling rate which is changed from at least one block of the first sampling rate comprised in the image previously decoded, wherein the at least one block of the first sampling rate is based on another residue of the first sampling rate, and the another residue of the first sampling rate is to be included in a bitstream and is related to the image previously decoded and generate the prediction block of the current block of the first sampling rate which is same as the first sampling rate of the residue by changing the generated prediction block of the second sampling rate to the prediction block of the first sampling rate; and
 determining the residue of the first sampling rate regarding the current block by using the generated prediction block of the first sampling rate, and generating the bitstream comprising the determined residue of the first sampling rate,
 wherein the first sampling rate is higher than the second sampling rate.

* * * * *