



US011021862B2

(12) **United States Patent**  
**Schuster**

(10) **Patent No.:** **US 11,021,862 B2**  
(45) **Date of Patent:** **Jun. 1, 2021**

(54) **TOILET SEALS**

- (71) Applicant: **Danco, Inc.**, Irving, TX (US)
- (72) Inventor: **Michael J. Schuster**, Shorewood, IL (US)
- (73) Assignee: **Danco, Inc.**, Irving, TX (US)
- (\* ) Notice: Subject to any disclaimer, the term of this patent is extended or adjusted under 35 U.S.C. 154(b) by 0 days.

- (21) Appl. No.: **15/944,442**
- (22) Filed: **Apr. 3, 2018**

- (65) **Prior Publication Data**  
US 2018/0258629 A1 Sep. 13, 2018

**Related U.S. Application Data**

- (63) Continuation of application No. 13/771,773, filed on Feb. 20, 2013, now Pat. No. 10,683,653.
- (60) Provisional application No. 61/600,794, filed on Feb. 20, 2012, provisional application No. 61/667,377, filed on Jul. 2, 2012.

- (51) **Int. Cl.**  
*E03D 11/16* (2006.01)  
*E03D 11/17* (2006.01)  
*F16L 5/10* (2006.01)

- (52) **U.S. Cl.**  
CPC ..... *E03D 11/16* (2013.01); *E03D 11/17* (2013.01); *F16L 5/10* (2013.01); *Y10T 29/49826* (2015.01)

- (58) **Field of Classification Search**  
CPC ..... E03D 11/16–17  
USPC ..... 4/252.1–252.6, 300; 285/56–60  
See application file for complete search history.

(56) **References Cited**

U.S. PATENT DOCUMENTS

1,333,368 A	3/1920	Auer
2,427,431 A	9/1947	Wieland
2,750,216 A	12/1953	Thies
2,908,513 A	10/1956	Karlinski
2,976,543 A	3/1961	Turner et al.
3,224,014 A	12/1965	Pietrzak
3,238,538 A	3/1966	Turner

(Continued)

FOREIGN PATENT DOCUMENTS

BR	102013031190	4/2016
CA	2137033	5/1996

(Continued)

OTHER PUBLICATIONS

Non-final Office Action dated Dec. 4, 2015 in related U.S. Appl. No. 13/771,773.

(Continued)

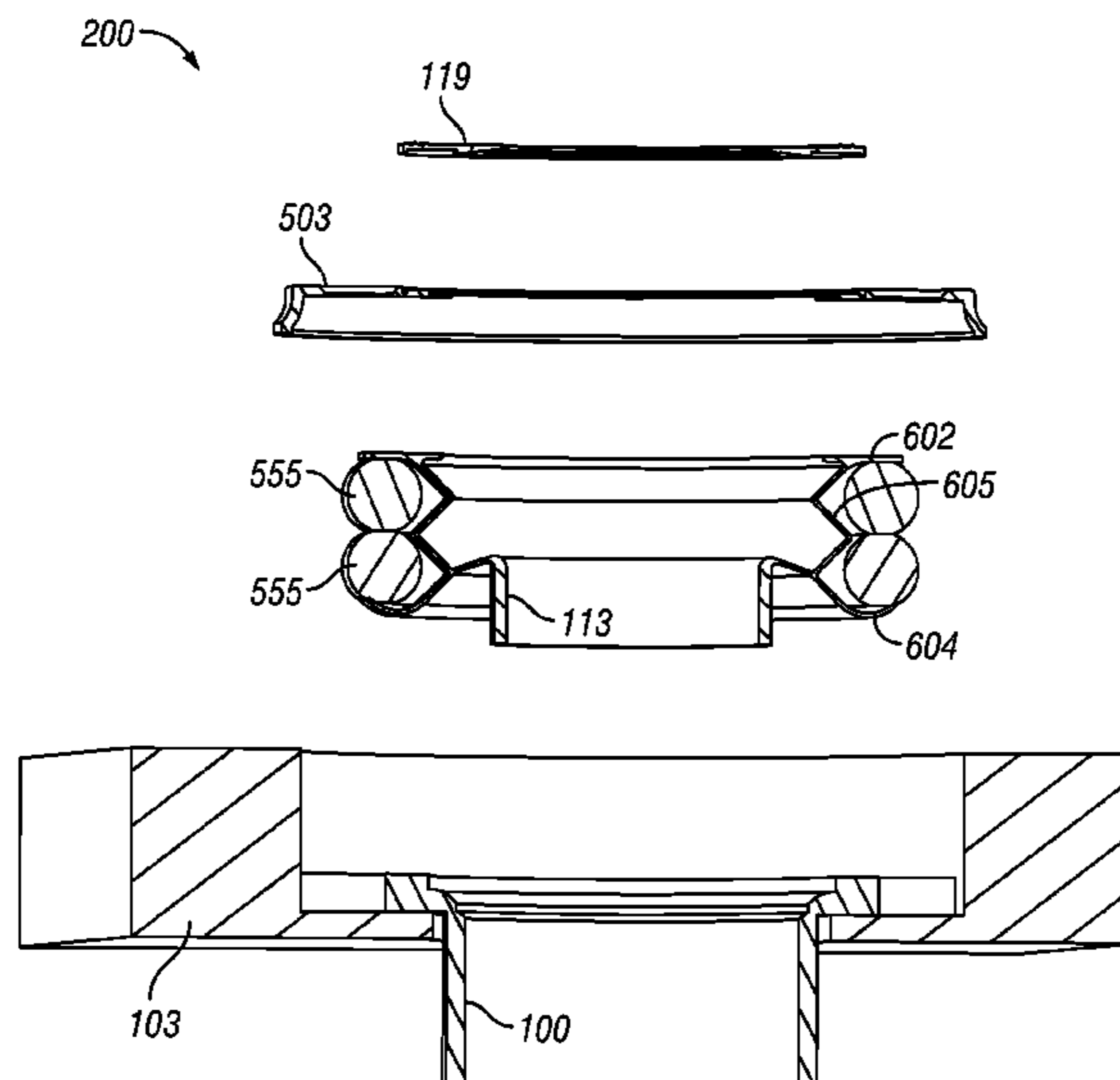
*Primary Examiner* — David P Angwin  
*Assistant Examiner* — William R Klotz

(74) *Attorney, Agent, or Firm* — Thomas | Horstemeyer, LLP

(57) **ABSTRACT**

Disclosed are various embodiments for facilitating the installation of a toilet over a closet collar for a drain pipe. According to various embodiments, a toilet seal assembly is positioned between the toilet and the closet collar, providing a seal between the toilet and the flange of the closet collar. The toilet seal assembly may include a flexible rubber seal and a compressible foam seal ring. The flexible rubber seal may include an annular wall, an upper ring that extends radially inward from the annular wall, and a lower ring that extends radially outward from the annular wall. The compressible foam seal ring may be disposed on the lower ring of the flexible rubber seal.

**30 Claims, 47 Drawing Sheets**



(56)

References Cited

FOREIGN PATENT DOCUMENTS

U.S. PATENT DOCUMENTS

3,349,412 A 10/1967 Schwartz et al.  
 3,400,411 A 9/1968 Harvey  
 3,501,172 A \* 3/1970 Pickard ..... E03D 11/16  
 285/374  
 3,821,820 A 7/1974 Thompson  
 3,952,340 A 4/1976 Cuschera  
 4,090,267 A 5/1978 Cuschera  
 4,237,667 A 12/1980 Pallucci et al.  
 4,406,480 A 9/1983 Izzi  
 4,482,161 A 11/1984 Izzi, Sr.  
 4,502,166 A 3/1985 Brown  
 4,515,398 A 5/1985 Machon, Sr.  
 5,018,224 A 5/1991 Hodges  
 5,185,890 A 2/1993 Dismore et al.  
 5,219,619 A 6/1993 Trouve et al.  
 5,377,361 A 1/1995 Piskula  
 5,432,957 A 7/1995 Fernie et al.  
 5,695,222 A 12/1997 Hodges  
 5,862,533 A 1/1999 Johnson et al.  
 6,332,632 B1 12/2001 Hodges  
 6,519,784 B2 2/2003 Carwile  
 6,581,214 B1 6/2003 Love et al.  
 6,644,670 B2 11/2003 Etcheverry  
 6,691,331 B2 2/2004 Gallacher et al.  
 6,694,537 B2 2/2004 Telles  
 6,719,294 B2 4/2004 Nguyen et al.  
 6,745,408 B2 6/2004 Spells, Sr.  
 6,789,275 B2 9/2004 Spells et al.  
 6,883,187 B2 4/2005 Cornwall  
 7,069,603 B2 7/2006 Flushing  
 D574,931 S 8/2008 Hughes  
 7,584,970 B2 9/2009 Ponce  
 7,814,580 B2 10/2010 Coronado et al.  
 8,069,502 B2 12/2011 Coronado  
 8,099,801 B2 1/2012 Hughes  
 D656,591 S 3/2012 Miller et al.  
 8,671,470 B2 3/2014 Miller et al.  
 8,875,320 B2 11/2014 Peñúñuri et al.  
 8,955,172 B2 2/2015 Culwell  
 9,062,445 B2 6/2015 Duncan et al.  
 9,273,455 B2 3/2016 Schuster  
 9,512,605 B2 12/2016 Duncan  
 9,556,603 B2 1/2017 Guthrie  
 9,663,934 B2 5/2017 Duncan  
 9,816,261 B2 11/2017 Schuster  
 10,017,932 B2 7/2018 Mehari  
 10,100,505 B2 10/2018 Coronado  
 10,151,095 B2 12/2018 Coronado et al.  
 10,280,606 B1 5/2019 Smith  
 10,294,647 B2 5/2019 Fong et al.  
 2001/0023505 A1 9/2001 Atkins  
 2001/0040348 A1 11/2001 Kojima  
 2003/0009820 A1 1/2003 Telles  
 2003/0052461 A1 3/2003 Ponce  
 2003/0126676 A1 7/2003 Gallacher et al.  
 2004/0098798 A1 5/2004 Atkins et al.  
 2004/0128752 A1 \* 7/2004 Atkins ..... E03D 11/17  
 4/252.6  
 2004/0163165 A1 8/2004 Ortiz et al.  
 2005/0108814 A1 5/2005 Thompson  
 2005/0278841 A1 12/2005 Coronado et al.  
 2006/0225195 A1 10/2006 Scholer  
 2007/0256220 A1 11/2007 Lee et al.  
 2009/0119826 A1 5/2009 Coronado  
 2009/0165195 A1 7/2009 Atkins et al.  
 2010/0037376 A1 2/2010 Hughes  
 2010/0123307 A1 5/2010 Coronado  
 2011/0094024 A1 4/2011 Grech et al.  
 2011/0185487 A1 8/2011 Miller et al.  
 2011/0185488 A1 8/2011 Miller et al.  
 2014/0062035 A1 3/2014 Coronado et al.  
 2014/0366256 A1 12/2014 Coronado  
 2017/0321410 A1 11/2017 Connell  
 2019/0003170 A1 1/2019 Loggia et al.  
 2019/0085548 A1 3/2019 Guthrie

CA 2578327 8/2008  
 CN 2931606 8/2007  
 CN 106836429 6/2017  
 CN 107044163 8/2017  
 DE 2205532 8/1973  
 DE 2525203 12/1976  
 EP 1054112 11/2000  
 EP 1655528 10/2006  
 EP 3336268 6/2018  
 GB 1512600 6/1978  
 GB 1531449 11/1978  
 GB 2012902 8/1979  
 GB 1567326 5/1980  
 GB 2136905 9/1984  
 JP 7331726 12/1995  
 JP 2010007286 1/2010  
 KR 200388701 7/2005  
 KR 100841718 6/2008  
 KR 20090109601 10/2009  
 KR 20100007292 7/2010  
 KR 20110027239 3/2011  
 KR 101038117 5/2011  
 KR 101971165 4/2019  
 KR 101975327 5/2019  
 WO 0125556 4/2001  
 WO 0132996 5/2001  
 WO 0198595 12/2001  
 WO 2014016703 1/2014  
 WO 2016054771 4/2016

OTHER PUBLICATIONS

Final Office Action dated May 19, 2016 in related U.S. Appl. No. 13/771,773.  
 Non-final Office Action dated Oct. 25, 2016 in related U.S. Appl. No. 13/771,773.  
 Final Office Action dated May 18, 2017 in related U.S. Appl. No. 13/771,773.  
 Final Office Action dated Oct. 2, 2017 in related U.S. Appl. No. 13/771,773.  
 Notice of Allowance dated Aug. 20, 2015 in related U.S. Appl. No. 14/488,804.  
 Notice of Allowance dated Dec. 18, 2015 in related U.S. Appl. No. 14/488,804.  
 Non-final Office Action dated Dec. 3, 2015 in related U.S. Appl. No. 14/693,584.  
 Final Office Action dated May 19, 2016 in related U.S. Appl. No. 14/693,584.  
 Non-final Office Action dated Dec. 14, 2016 in related U.S. Appl. No. 14/693,584.  
 Final Office Action dated Jul. 28, 2017 in related U.S. Appl. No. 14/693,584.  
 Final Office Action dated Jan. 20, 2016 in related U.S. Appl. No. 13/974,918.  
 Non-final Office Action dated Apr. 7, 2016 in related U.S. Appl. No. 13/974,918.  
 Notice of Allowance dated Sep. 22, 2016 in related U.S. Appl. No. 13/974,918.  
 Notice of Allowance dated Jan. 10, 2017 in related U.S. Appl. No. 13/974,918.  
 Notice of Allowance dated Apr. 25, 2017 in related U.S. Appl. No. 13/974,918.  
 Final Office Action dated Jan. 20, 2016 in related U.S. Appl. No. 14/693,472.  
 Non-final Office Action dated Mar. 18, 2016 in related U.S. Appl. No. 14/693,472.  
 Notice of Allowance dated Aug. 26, 2016 in related U.S. Appl. No. 14/693,472.  
 Notice of Allowance dated Jan. 3, 2017 in related U.S. Appl. No. 14/693,472.  
 Notice of Allowance dated May 8, 2017 in related U.S. Appl. No. 14/693,472.



(56)

## References Cited

## OTHER PUBLICATIONS

Notice of Allowance dated Feb. 17, 2017 in related U.S. Appl. No. 15/407,620.

Notice of Allowance dated Jan. 30, 2017 in related U.S. Appl. No. 15/407,620.

Non-final Office Action dated Jan. 31, 2018 in related U.S. Appl. No. 15/791,950.

U.S. Appl. No. 09/904,058, filed Jul. 11, 2011, now U.S. Pat. No. 6,694,537.

Non-Final Office Action in related U.S. Appl. No. 13/974,918 dated Jun. 12, 2015.

Non-Final Office Action in related U.S. Appl. No. 14/693,472, dated Jul. 20, 2015.

Non-Final Office Action in related U.S. Appl. No. 14/488,804 dated May 21, 2015.

Elastic Toilet Gasket (Wax Free) with Toilet Bolts Included—EG1002—The Home Depot Date. (<https://www.homedepot.com/p/Elastic-Toilet-Gasket-Wax-Free-with-Toilet-Bolts-Included-EG>) Access Date: Jul. 15, 2019.

BlueSeal Toilet Donut Seal Ring—Superior to Standard Wax Rings—Ends Toilet Base Leaking and Subfloor Damage—Amazon.com. Date First Available: Jan. 2, 2017 (<https://www.amazon.com/BlueSeal-Toilet-Donut-Seal-Ring/dp/B00MQAT3UA>) Access Date: Jul. 15, 2019.

Fernco Inc. Available Fernco FTS-3 3-Inch Wax Free Toilet Seal—Wax Gasket—Amazon.com. Date First Available: May 3, 2006. ([https://www.amazon.com/Fernco-Available-FTS-3-3-Inch-Toilet/dp/B000BQUJEA/ref=pd\\_rhf](https://www.amazon.com/Fernco-Available-FTS-3-3-Inch-Toilet/dp/B000BQUJEA/ref=pd_rhf)) Access Date: Jul. 15, 2019.

Sticky Elastomer Toilet Gasket Kit with Extension and Bolts-TFK-123—The Home Depot. (<https://www.homedepot.com/p/Sticky-Elastomer-Toilet-Gasket-Kit-with-Extension-and-Bolts>) Access Date: Jul. 15, 2019.

Fernco Inc. FTS-4 Wax Free Toilet Seal, 4-Inch, Iron—Toilet and Urinal Parts—Amazon.com. Date First Available: Feb. 17, 2007. ([https://www.amazon.com/Fernco-Inc-FTS-4-Toilet-4-Inch/dp/B000BVMZUG/ref=pd\\_sbs\\_60\\_](https://www.amazon.com/Fernco-Inc-FTS-4-Toilet-4-Inch/dp/B000BVMZUG/ref=pd_sbs_60_)) Access Date: Jul. 15, 2019.

EasyDrain Ref. 030706-424 Soft Rubber Universal Better Than Wax Toilet seat Seal, Wax-Free Toilet Bowl Gasket—Amazon.com. Date First Available: Oct. 4, 2017 ([https://www.amazon.com/dp/B07666QBYS/ref=sspa\\_dk\\_detail\\_4?psc=1](https://www.amazon.com/dp/B07666QBYS/ref=sspa_dk_detail_4?psc=1)) Access Date: Jul. 15, 2019.

Plumbcraft 7140300 Seal Tight Waxless Gasket Kit-Universal FIT Any Toilet—Amazon.com. Date First Available: Sep. 7, 2016. ([https://www.amazon.com/dp/B01LQIH3XQ/ref=psdc\\_3226967011\\_t3\\_B00NOD4R7M](https://www.amazon.com/dp/B01LQIH3XQ/ref=psdc_3226967011_t3_B00NOD4R7M)) Access Date: Jul. 15, 2019.

Korky 6000BP Universal Toilet WaxFree Seal with Hardware—Toilet Installation Made Easy—Made in USA—Amazon.com. Date First Available: Sep. 18, 2014 (<https://www.amazon.com/Korky-6000BP-Universal-WaxFree-Hardware/dp/B00NOD4R7M/re>) Access Date: Jul. 15, 2019.

Fluidmaster 7530P8 Universal Better Than Wax Toilet Seal, Wax-Free Toilet Bowl Gasket—Amazon.com. Date First Available: Dec. 19, 2014. (<https://www.amazon.com/Fluidmaster-7530P8-Universal-Better-Wax-Free/dp/B00R7D35TQ/r>) Access Date: Jul. 15, 2019.

Sani Seal Llc BL01 Waxless Toilet Gasket—Toilet Wax Seal—Amazon.com. Date First Available: Dec. 4, 2010 ([https://www.amazon.com/Sani-BL01-Waxless-Toilet-Gasket/dp/B005K89RQU/ref=pd\\_cp\\_60](https://www.amazon.com/Sani-BL01-Waxless-Toilet-Gasket/dp/B005K89RQU/ref=pd_cp_60)) Access Date: Jul. 15, 2019.

Examiner's Report dated Dec. 17, 2018 for Application No. 2,806,916. [Proposed] Order Denying Danco, Inc.'s Motion to Dismiss/Strike Defendant's Inequitable Counterclaim/Affirmative Defense for Failure to State a Claim filed Mar. 31, 2017 in the litigation case of *Danco, Inc. v. Lavelle Industries, Inc.*, Civil Action No. 5:16-CV-00048-CMC.

Defendant Lavelle Industries, Inc.'s Proposed Second Amended Answer, Affirmative Defenses, and Counterclaims to Danco, Inc.'s Complaint for Patent Infringement filed Mar. 31, 2017 in the litigation case of *Danco, Inc. v. Lavelle Industries, Inc.*, Civil Action No. 5:16-CV-00048-CMC.

Defendant, Lavelle Industries, Inc.'s Answer, Affirmative Defenses and Counterclaims to Danco, Inc.'s Complaint for Patent Infringement filed on Aug. 8, 2016 in Case No. 5:16-CV-00048-CMC, Eastern District of Texas, Texarkana Division.

Defendant, Lavelle Industries, Inc.'s Amended Answer, Affirmative Defenses and Amended Counterclaim to Danco, Inc.'s Complaint for Patent Infringement filed Feb. 28, 2017 in the litigation case of *Danco, Inc. v. Lavelle Industries, Inc.*, Civil Action No. 5:16-CV-00048-CMC.

Email to Attorney Culbertson dated Sep. 12, 2016 in the litigation case of *Danco, Inc. v. Lavelle Industries, Inc.*, Civil Action No. 5:16-CV-00048-CMC.

Invalidity Contentions of Lavelle Industries, Inc. in the litigation case of *Danco, Inc. v. Lavelle Industries, Inc.*, Civil Action No. 5:16-CV-00048-CMC mailed on Oct. 11, 2016.

Lavelle Industries, Inc.'s Response to Danco, Inc.'s Motion to Dismiss/Strike Defendant's Inequitable Counterclaim/Affirmative Defense for Failure to State a Claim filed Mar. 31, 2017 in the litigation case of *Danco, Inc. v. Lavelle Industries, Inc.*, Civil Action No. 5:16-CV-00048-CMC.

Petition for Inter Partes Review under 35 U.S.C. 311-319 and 37 CFR 42.100, et, seq. filed on Oct. 28, 2016 in the *Lavelle Industries, Inc. v. Danco, Inc.* case, United States Patent and Trademark Office before the Patent Trial and Appeal Board for U.S. Pat. No. 9,273,455. Examiner's Report dated Jul. 16, 2019 for Application No. 2,806,916. Response to Examiners Report dated Dec. 17, 2018 dated Jun. 6, 2019 for Application No. 2,806,916.

Non-Final Office Action dated Jun. 14, 2018 for U.S. Appl. No. 13/771,773.

Notice of Allowance dated Mar. 26, 2019 for U.S. Appl. No. 15/791,950.

Notice of Allowance dated Apr. 30, 2019 for U.S. Appl. No. 15/791,950.

Notice of Allowance dated Aug. 8, 2017 for U.S. Appl. No. 13/974,918.

Notice of Allowance dated Aug. 13, 2019 for U.S. Appl. No. 15/791,950.

Notice of Allowance dated Aug. 18, 2017 for U.S. Appl. No. 14/693,472.

Notice of Allowance dated Aug. 18, 2017 for U.S. Appl. No. 15/407,620.

Notice of Allowance dated Dec. 14, 2018 for U.S. Appl. No. 15/791,950.

Notice of Allowance dated Jan. 29, 2016 for U.S. Appl. No. 14/488,804.

Notice of Allowance dated Sep. 27, 2019 for U.S. Appl. No. 13/771,773.

Notice of Appeal dated Mar. 26, 2019 for U.S. Appl. No. 14/693,584. Final Office Action dated Aug. 14, 2018 for U.S. Appl. No. 15/791,950.

Final Office Action dated Dec. 27, 2018 for U.S. Appl. No. 13/771,773.

Response to Final Office Action dated Jan. 20, 2016 dated Feb. 9, 2016 for U.S. Appl. No. 14/693,472.

Response to Final Office Action dated Jan. 20, 2016 dated Mar. 15, 2016 for U.S. Appl. No. 13/974,918.

Response to Final Office Action dated Aug. 14, 2018 dated Nov. 14, 2018 for U.S. Appl. No. 15/791,950.

Response to Final Office Action dated May 18, 2017 dated Aug. 18, 2017 for U.S. Appl. No. 13/771,773.

Response to Final Office Action dated May 19, 2016 dated Jul. 15, 2016 for U.S. Appl. No. 13/771,773.

Response to Final Office Action dated Oct. 2, 2017 dated Feb. 1, 2018 for U.S. Appl. No. 13/771,773.

Response to Final Office Action dated Dec. 27, 2018 dated Apr. 29, 2019 for U.S. Appl. No. 13/771,773.

Response to Non-Final Office Action dated Jan. 31, 2018 dated Apr. 30, 2018 for U.S. Appl. No. 15/791,950.

Response to Non-Final Office Action dated Mar. 18, 2016 dated May 13, 2016 for U.S. Appl. No. 14/693,472.

Response to Non-Final Office Action dated Apr. 7, 2016 dated Jun. 24, 2016 for U.S. Appl. No. 13/974,918.

(56)

**References Cited**

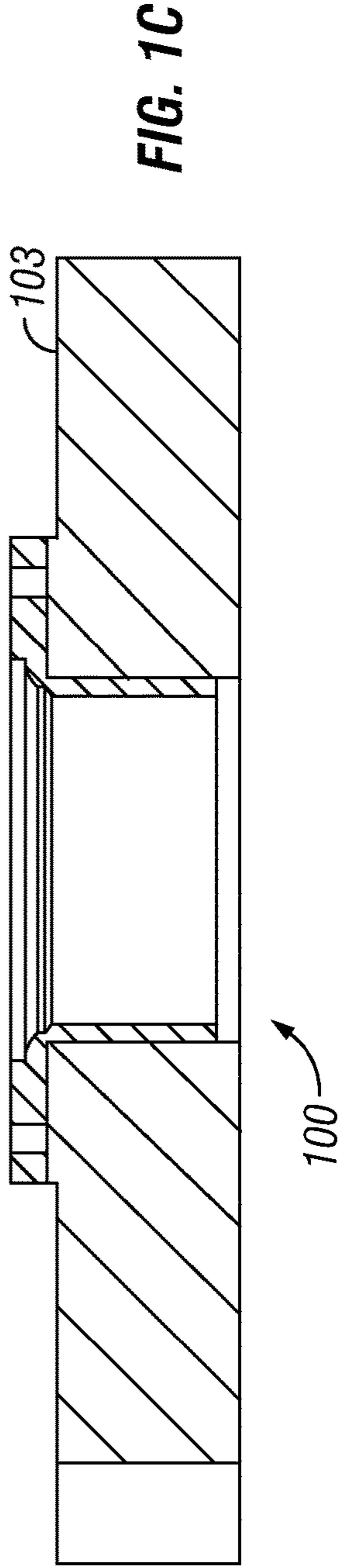
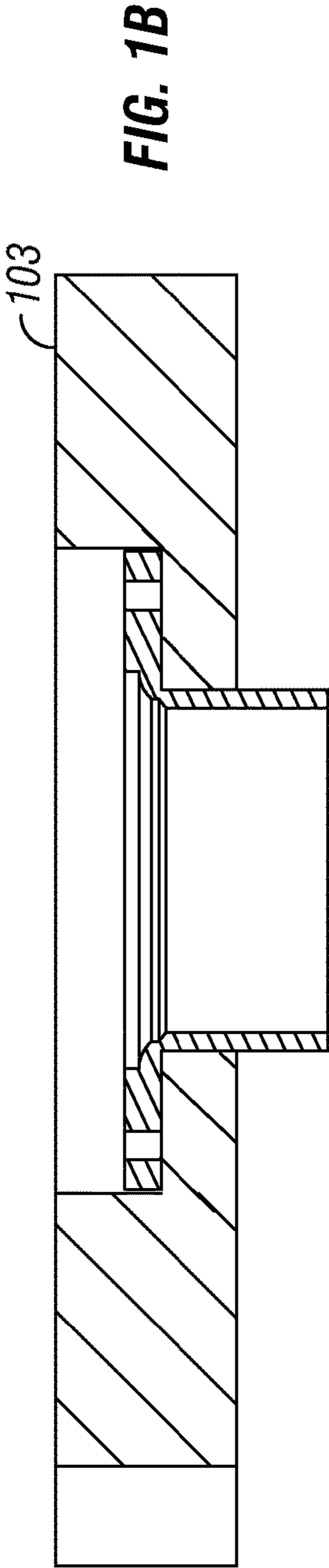
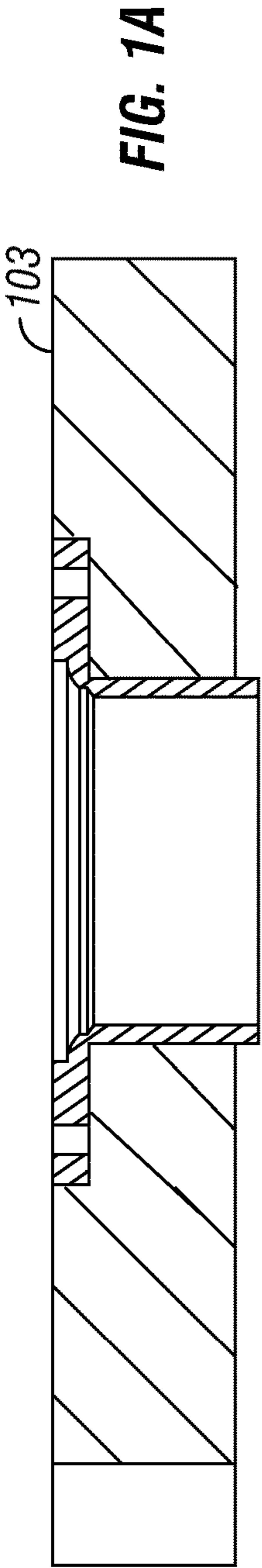
OTHER PUBLICATIONS

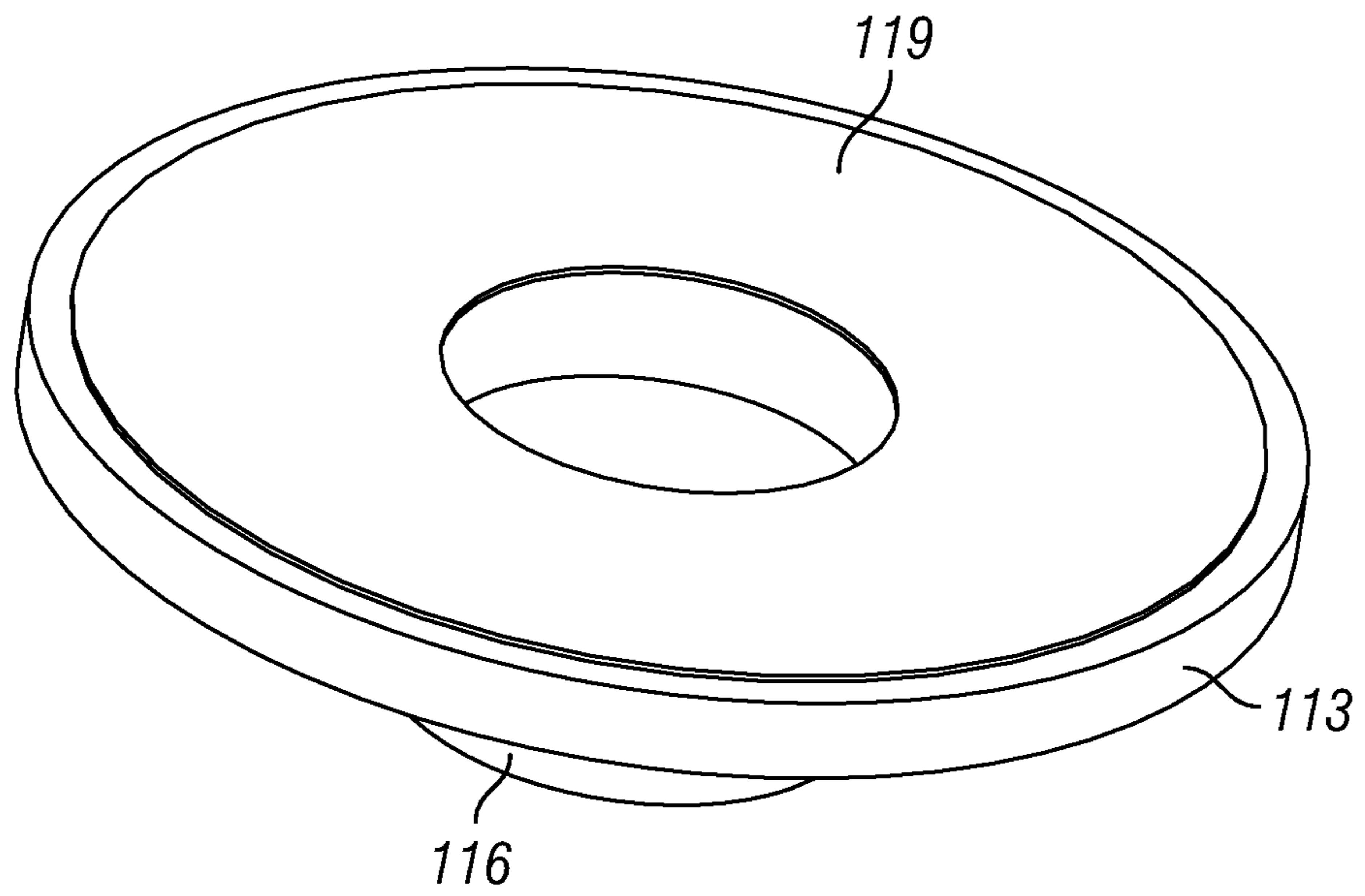
Response to Non-final Office Action dated May 21, 2015 dated Aug. 3, 2015 U.S. Appl. No. 14/488,804.  
Response to Non-Final Office Action dated Jun. 12, 2015 dated Oct. 8, 2015 for U.S. Appl. No. 13/974,918.  
Response to Non-Final Office Action dated Jul. 20, 2015 dated Oct. 13, 2015 for U.S. Appl. No. 14/693,472.  
Response to Non-Final Office Action dated Jun. 14, 2018 dated Nov. 6, 2018 for U.S. Appl. No. 13/771,773.  
Response to Non-Final Office Action dated Oct. 25, 2016 dated Jan. 23, 2017 for U.S. Appl. No. 13/771,773.  
Response to Non-Final Office Action dated Dec. 4, 2015 dated Feb. 10, 2016 for U.S. Appl. No. 13/771,773.  
Response to Restriction/Election dated Aug. 12, 2015 dated Nov. 9, 2015 for U.S. Appl. No. 13/771,773.  
Response to Restriction/Election dated Dec. 18, 2014 dated Jan. 19, 2015 for U.S. Appl. No. 14/488,804.  
Restriction/Election dated Aug. 12, 2015 for U.S. Appl. No. 13/771,773.  
Restriction/Election dated Dec. 18, 2014 for U.S. Appl. No. 14/488,804.

U.S. Appl. No. 14/693,584, filed Apr. 22, 2015, Final Office Action dated Dec. 27, 2018.  
U.S. Appl. No. 14/693,584, filed Apr. 22, 2015, Non-Final Office Action dated Jun. 5, 2018.  
U.S. Appl. No. 14/693,584, filed Apr. 22, 2015, Notice of Allowance dated Oct. 1, 2019.  
U.S. Appl. No. 14/693,584, filed Apr. 22, 2015, Response to Final Office Action dated May 19, 2016 dated Jul. 15, 2016.  
U.S. Appl. No. 14/693,584, filed Apr. 22, 2015, Response to Final Office Action dated Jul. 28, 2017 dated Oct. 23, 2017.  
U.S. Appl. No. 14/693,584, filed Apr. 22, 2015, Response to Non-Final Office Action dated Jun. 5, 2018 dated Oct. 5, 2018.  
U.S. Appl. No. 14/693,584, filed Apr. 22, 2015, Response to Non-Final Office Action dated Dec. 3, 2015 dated Jan. 19, 2016.  
U.S. Appl. No. 14/693,584, filed Apr. 22, 2015, Response to Non-Final Office Action dated Dec. 14, 2016 dated Apr. 14, 2017.  
U.S. Appl. No. 14/693,584, filed Apr. 22, 2015, Response to Restriction/Election dated Jul. 10, 2015 dated Oct. 8, 2015.  
U.S. Appl. No. 14/693,584, filed Apr. 22, 2015, Restriction/Election dated Jul. 10, 2015.

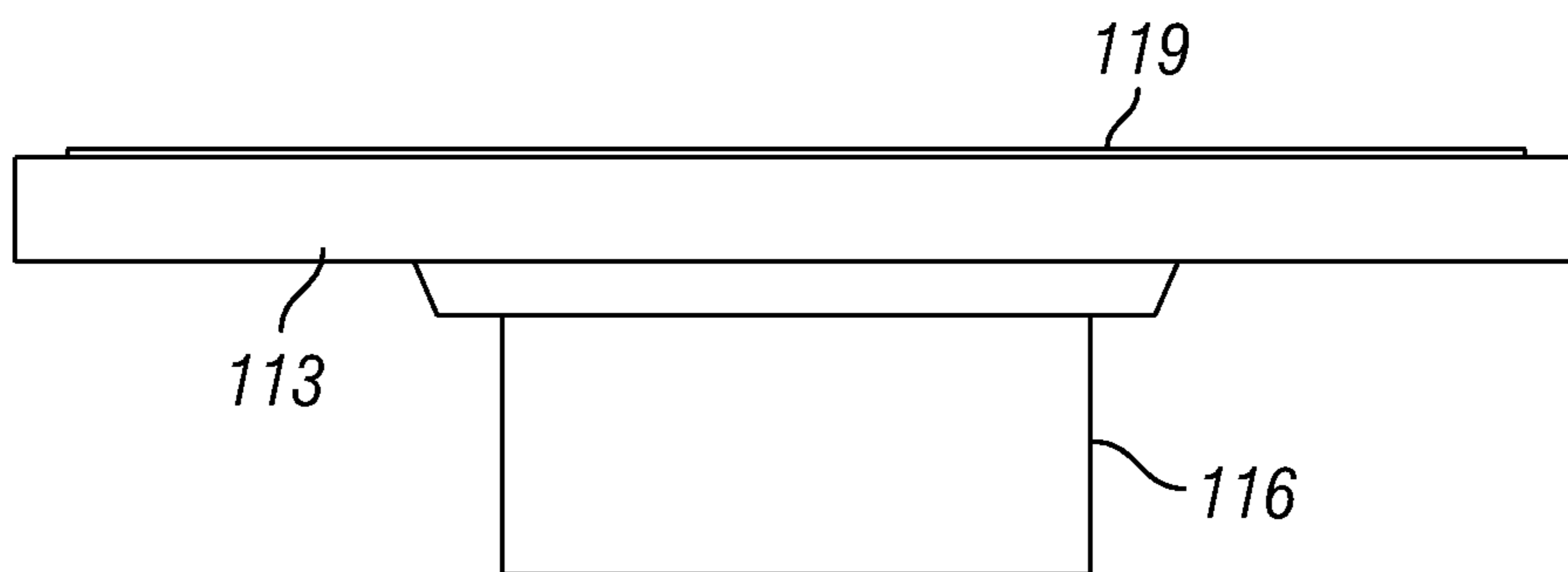
\* cited by examiner



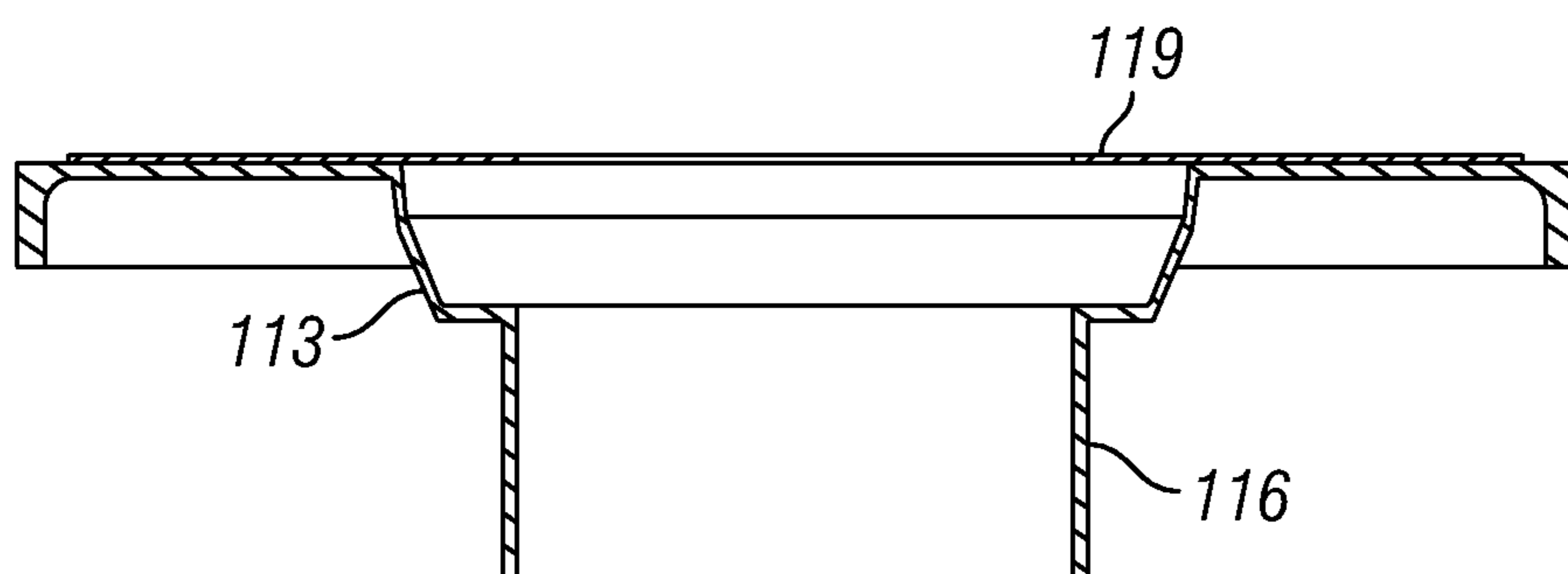




**FIG. 2A**



**FIG. 2B**



**FIG. 2C**

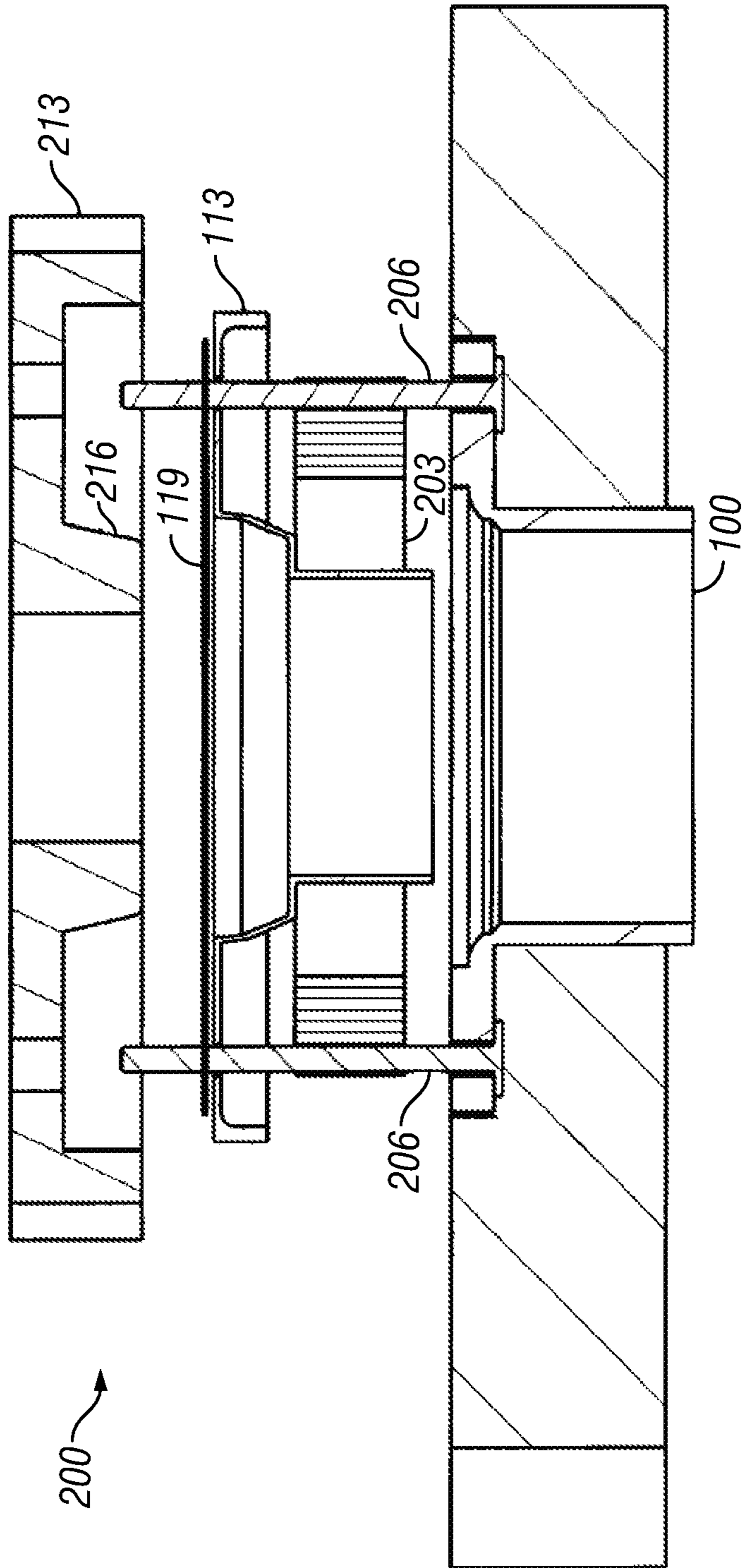


FIG. 3

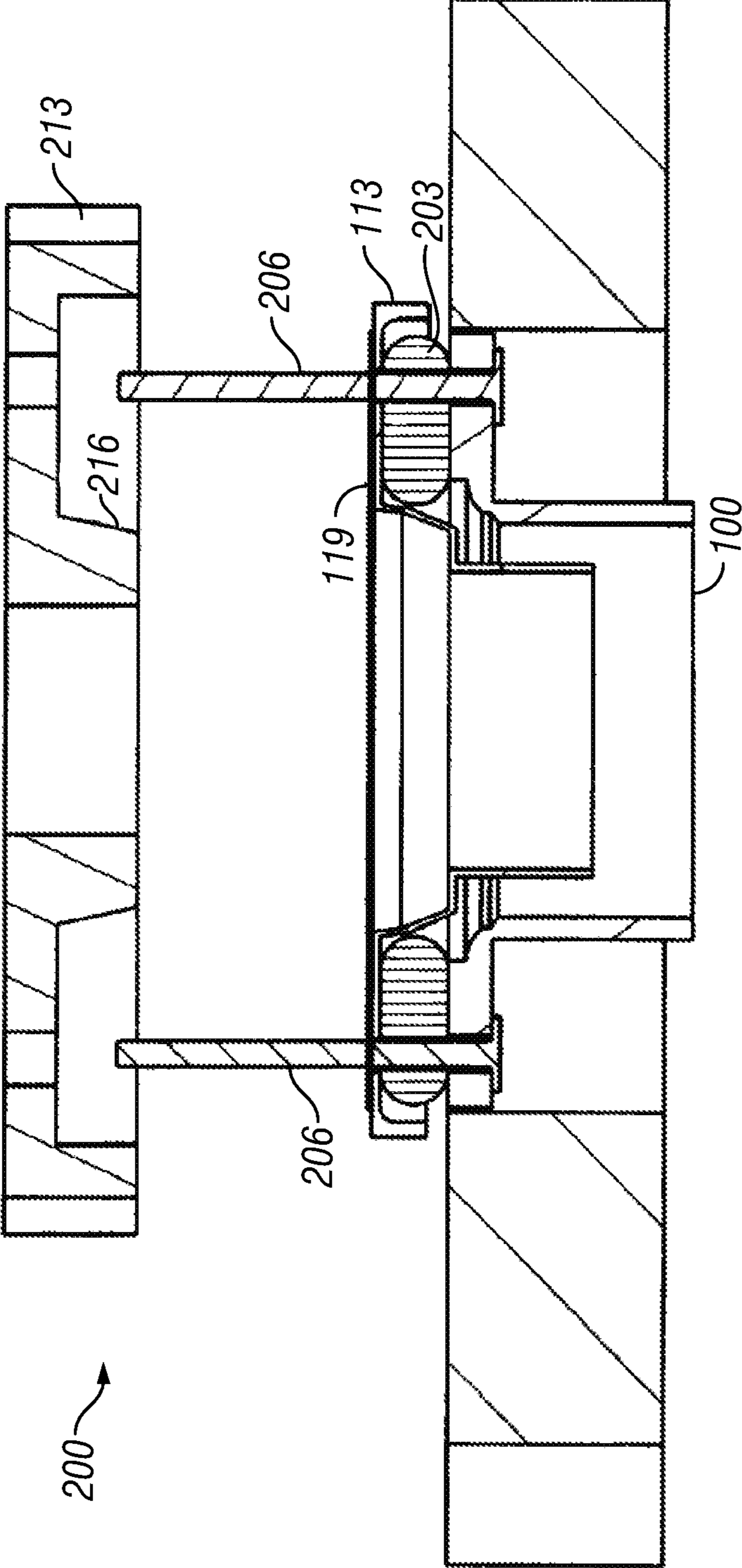


FIG. 4



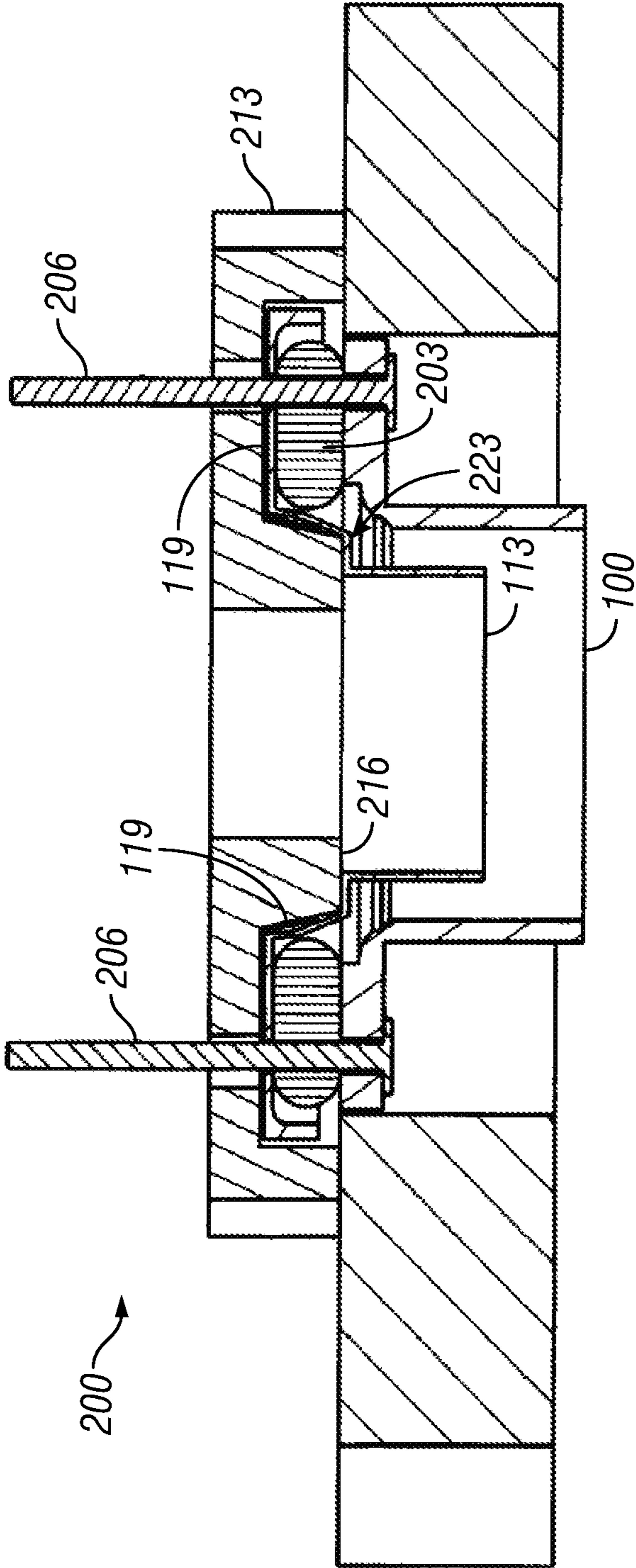


FIG. 5

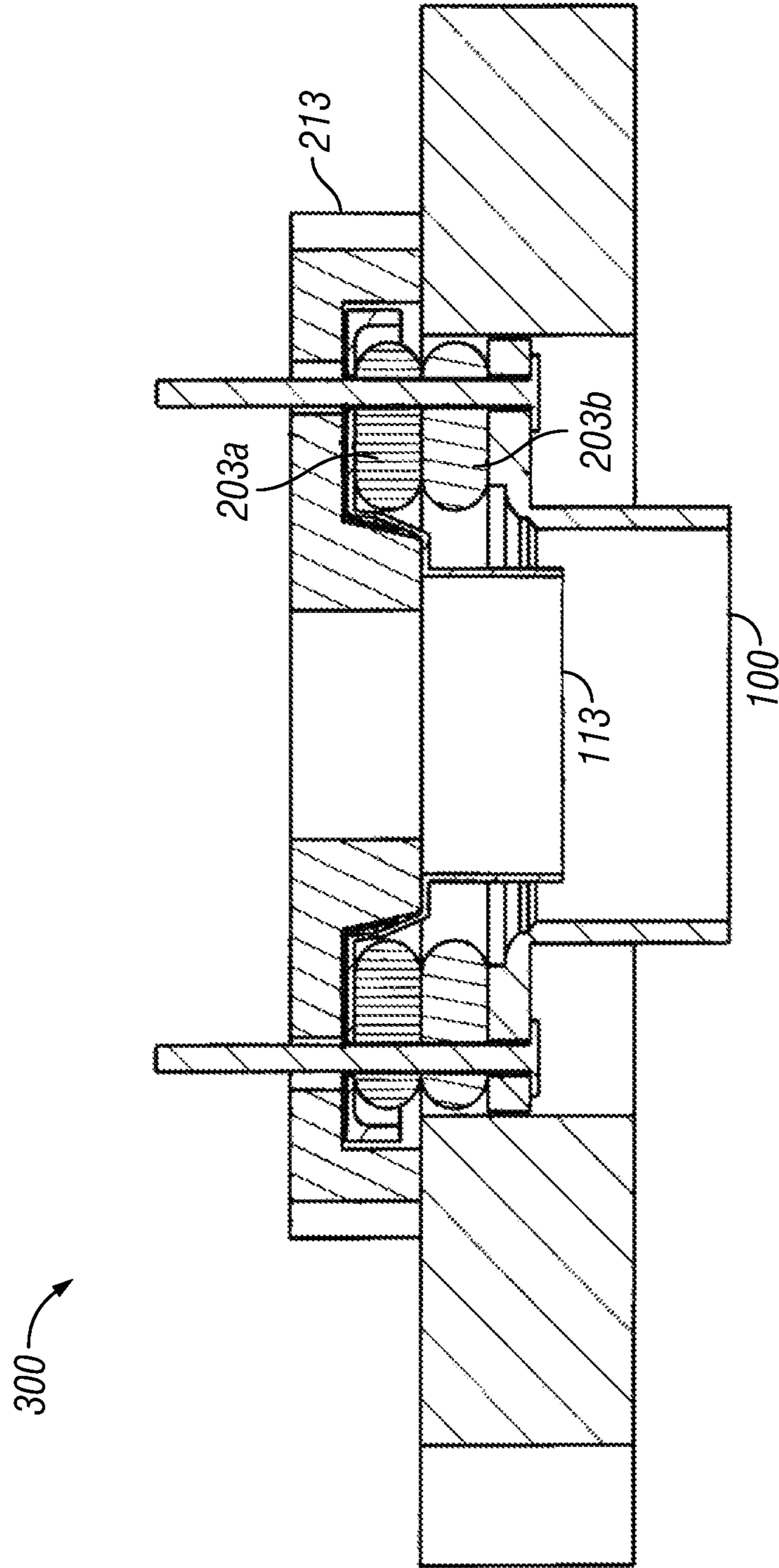


FIG. 6

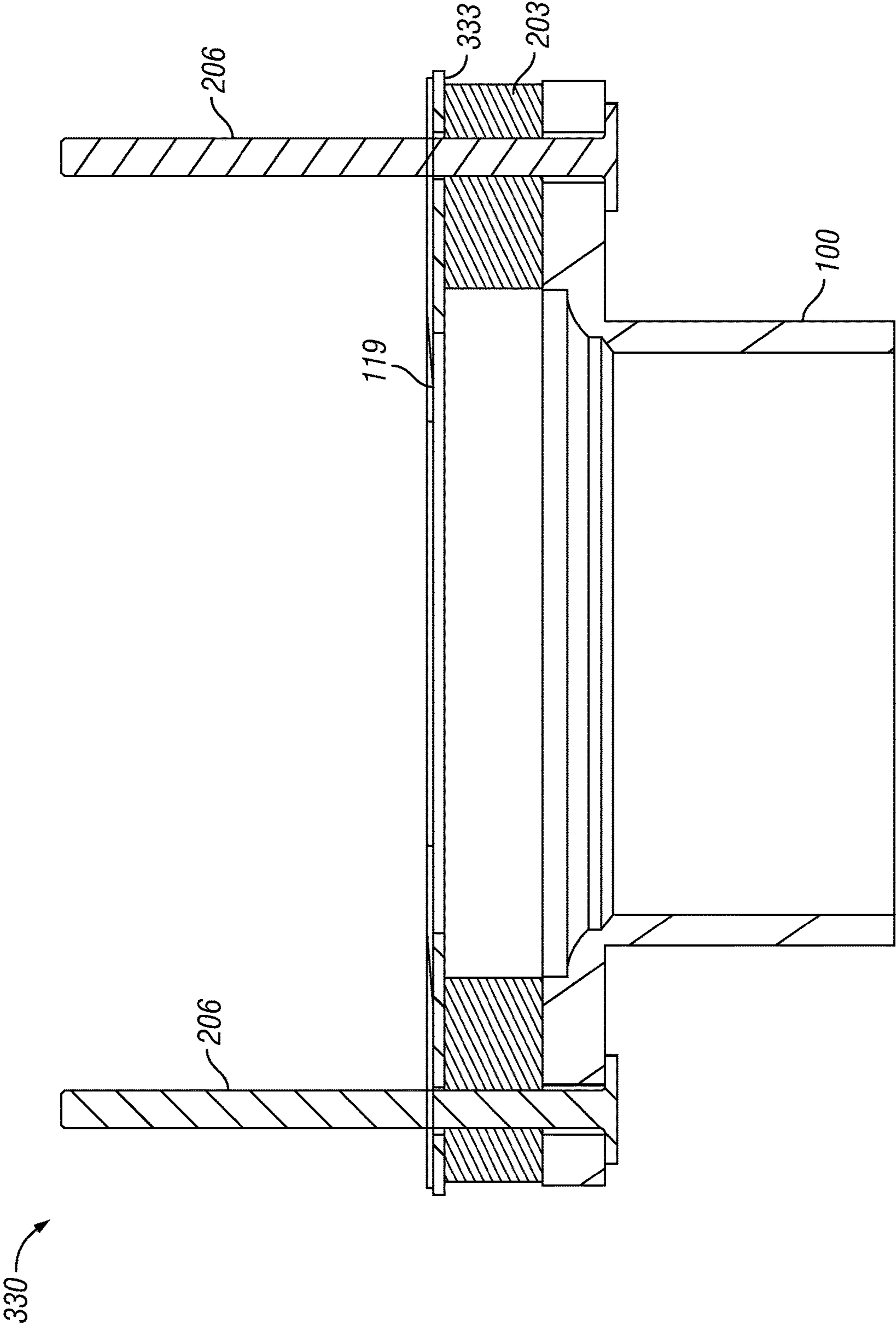


FIG. 7



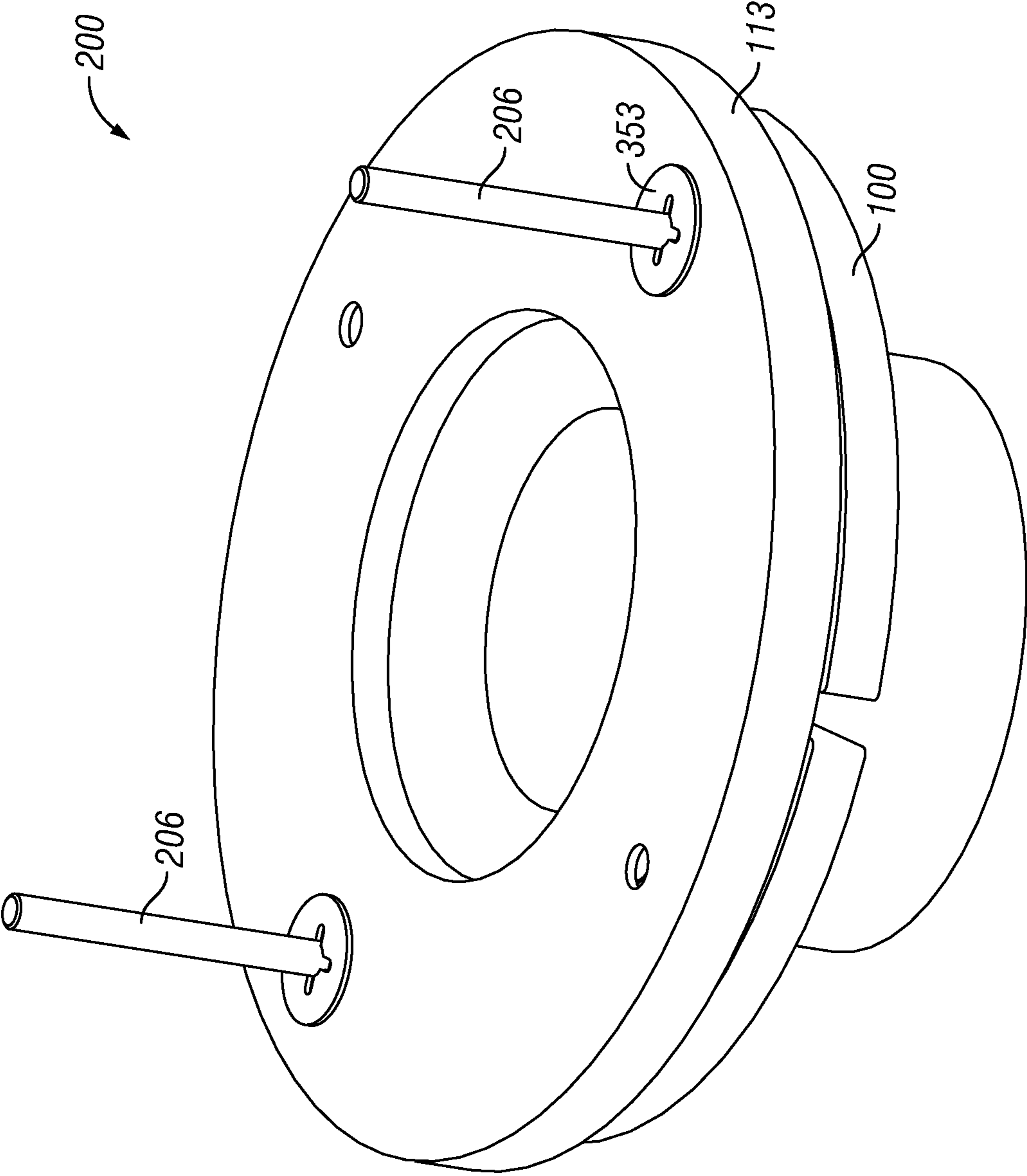


FIG. 8

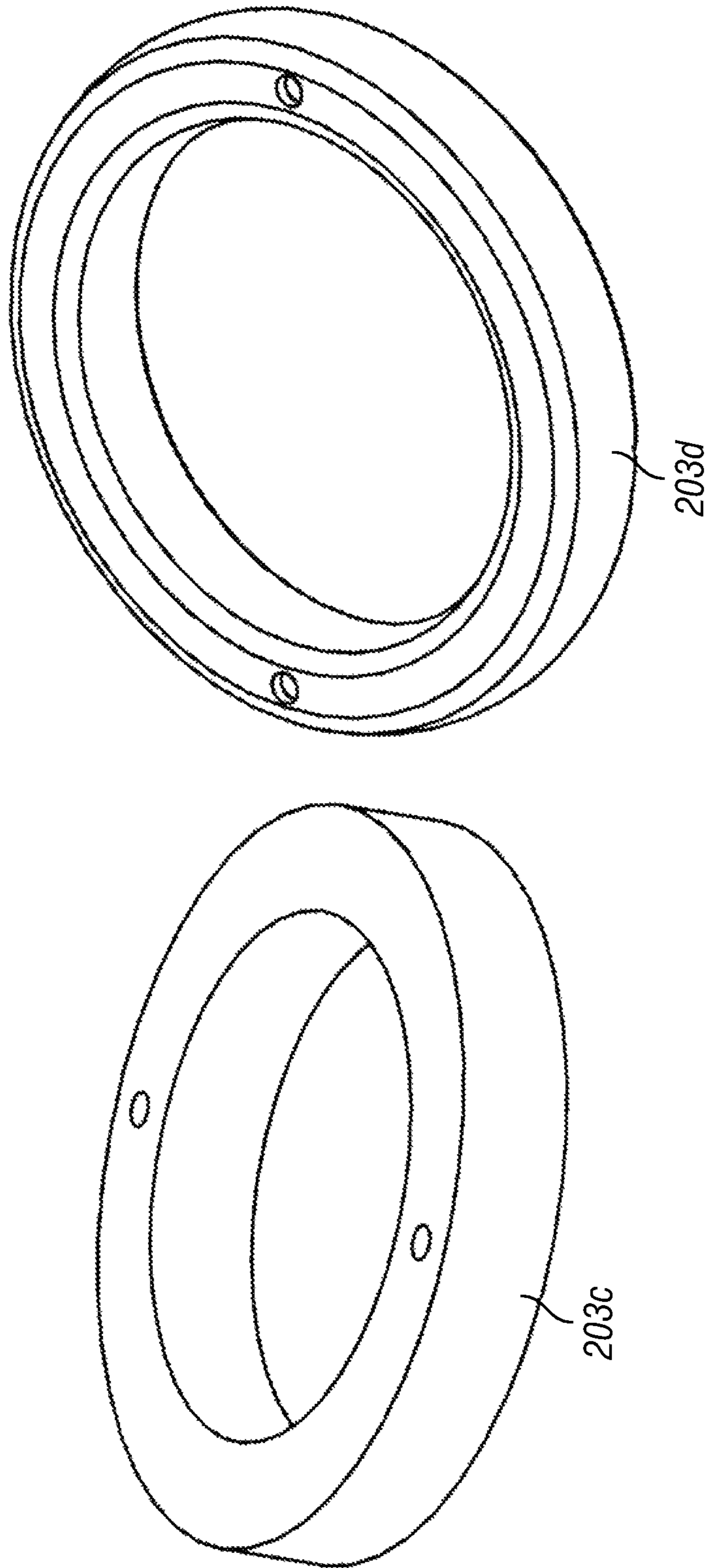
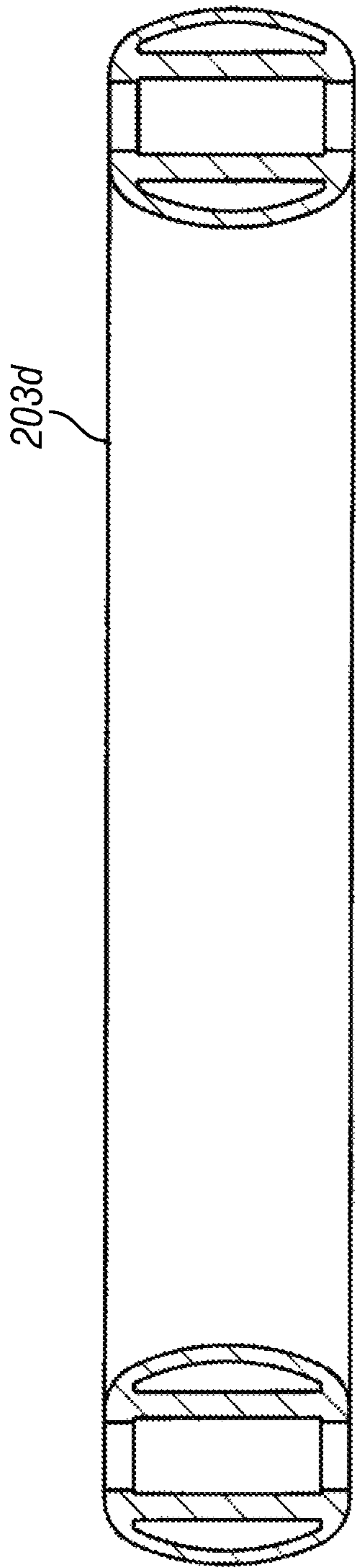
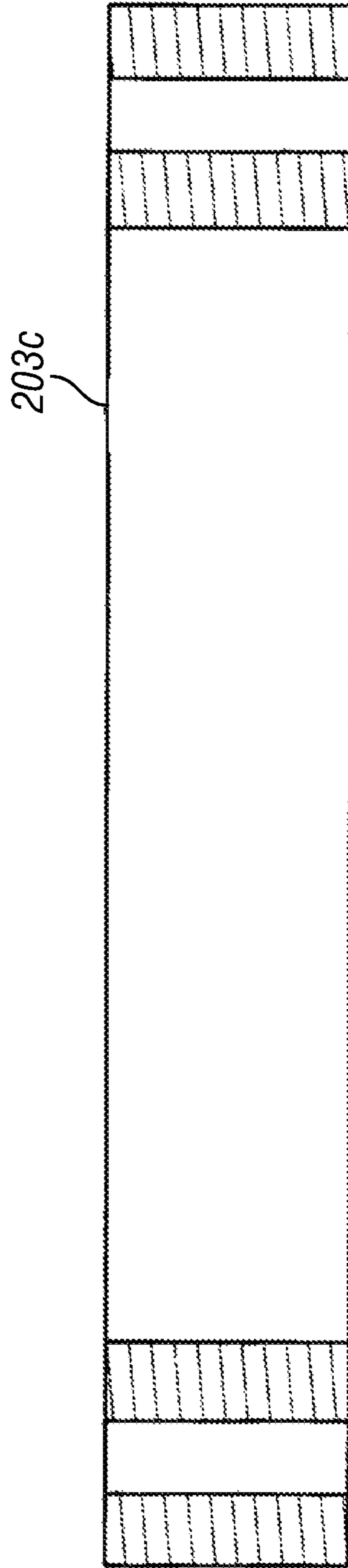


FIG. 9

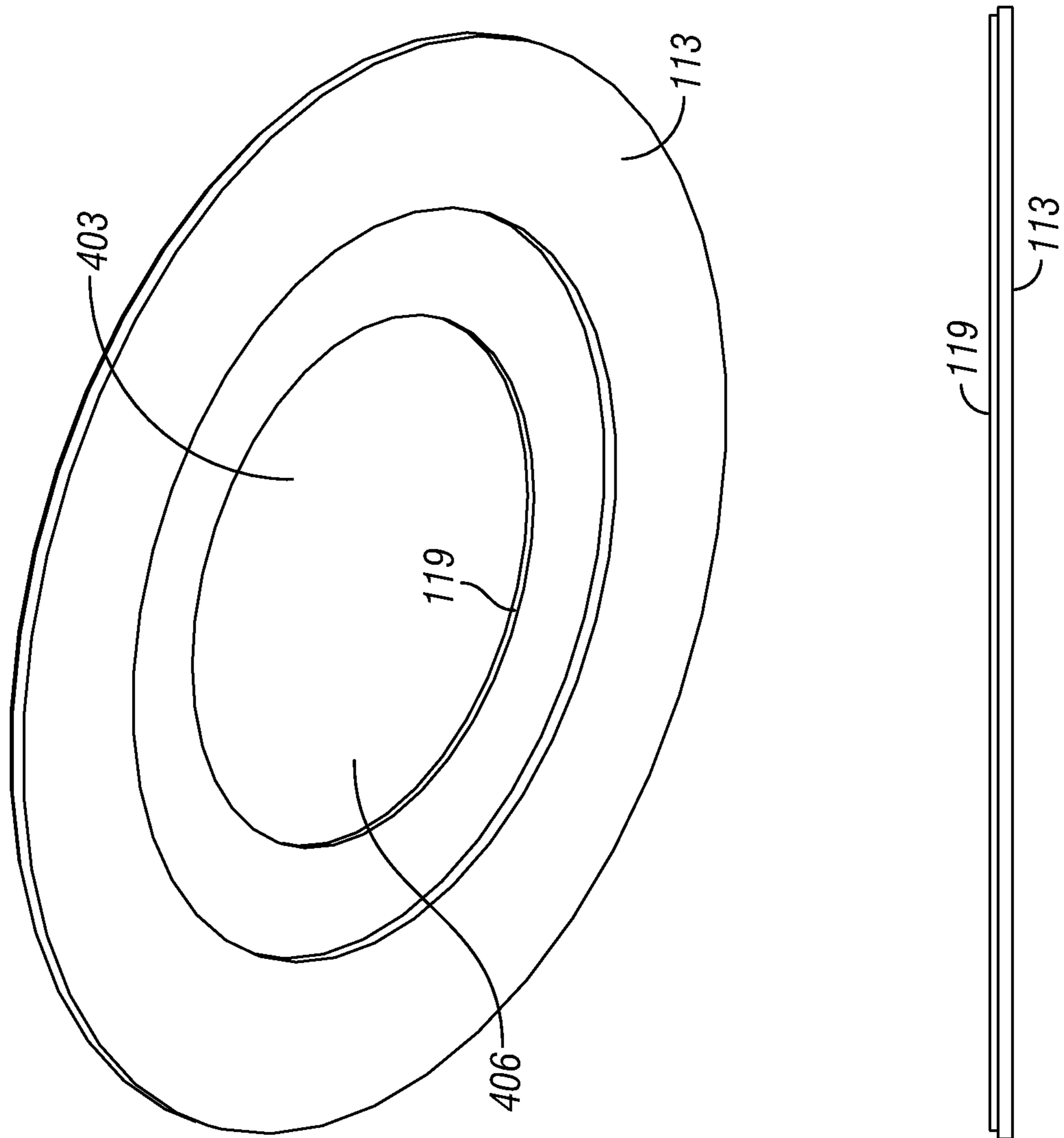


**FIG. 10A**



**FIG. 10B**





**FIG. 11**

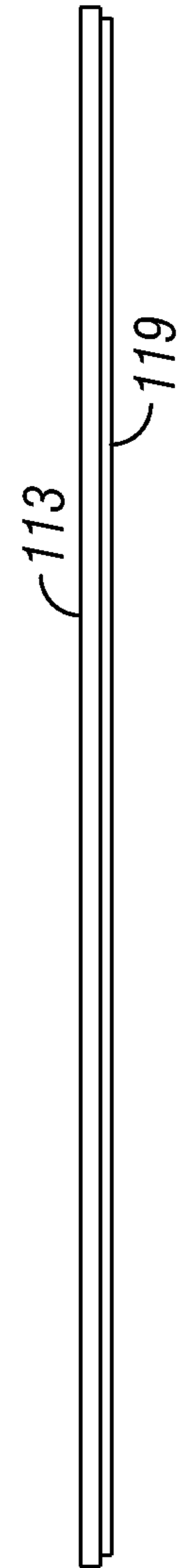
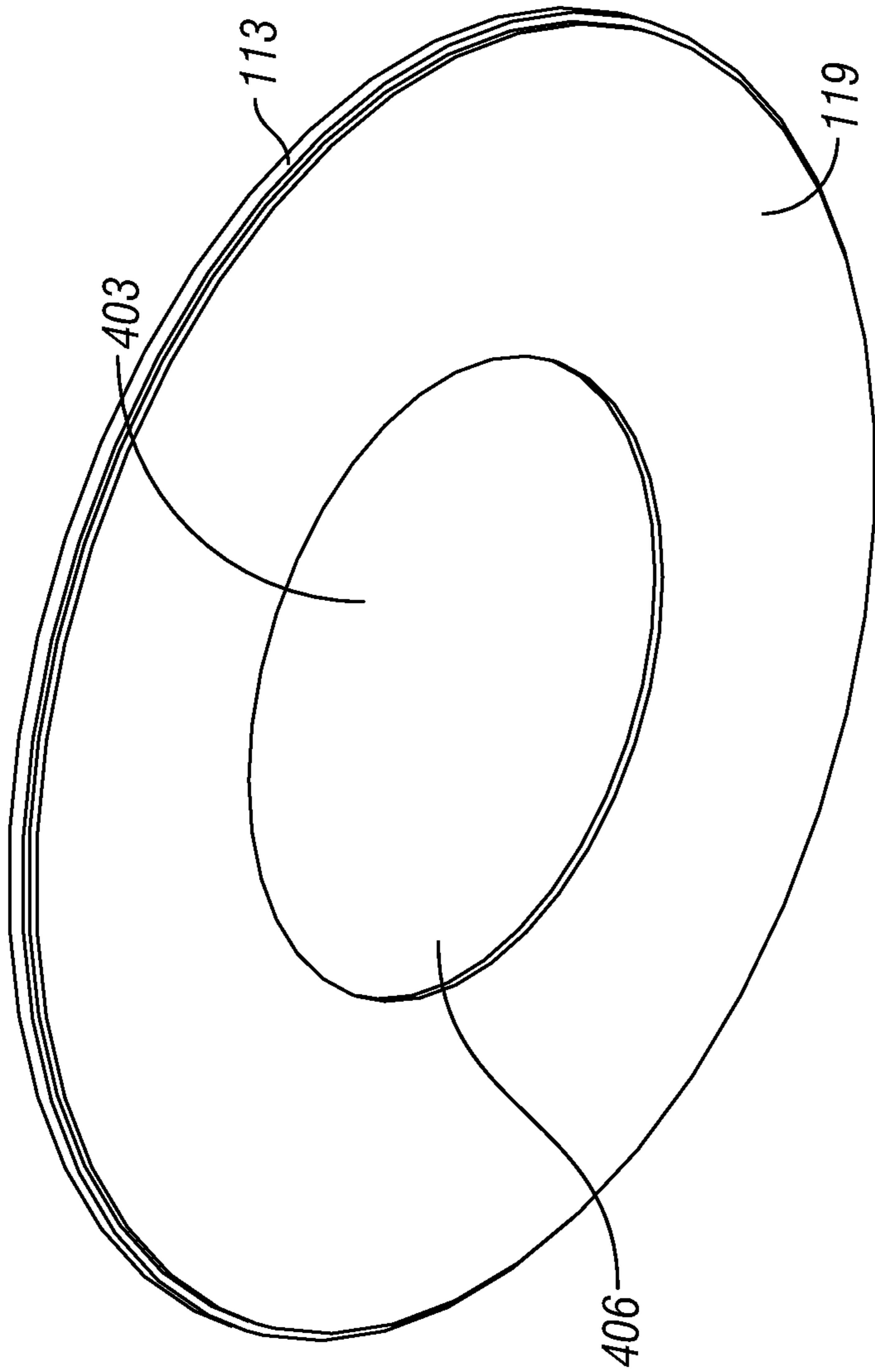


FIG. 12

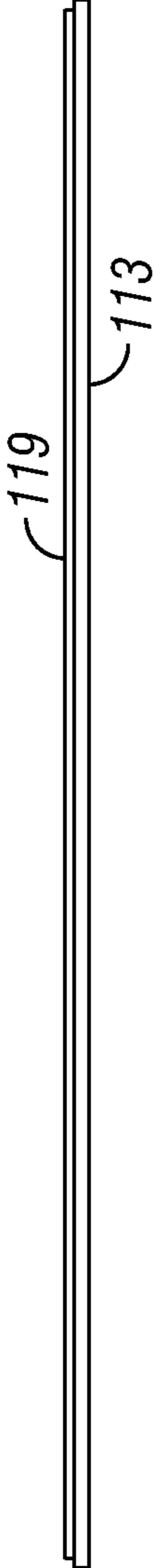
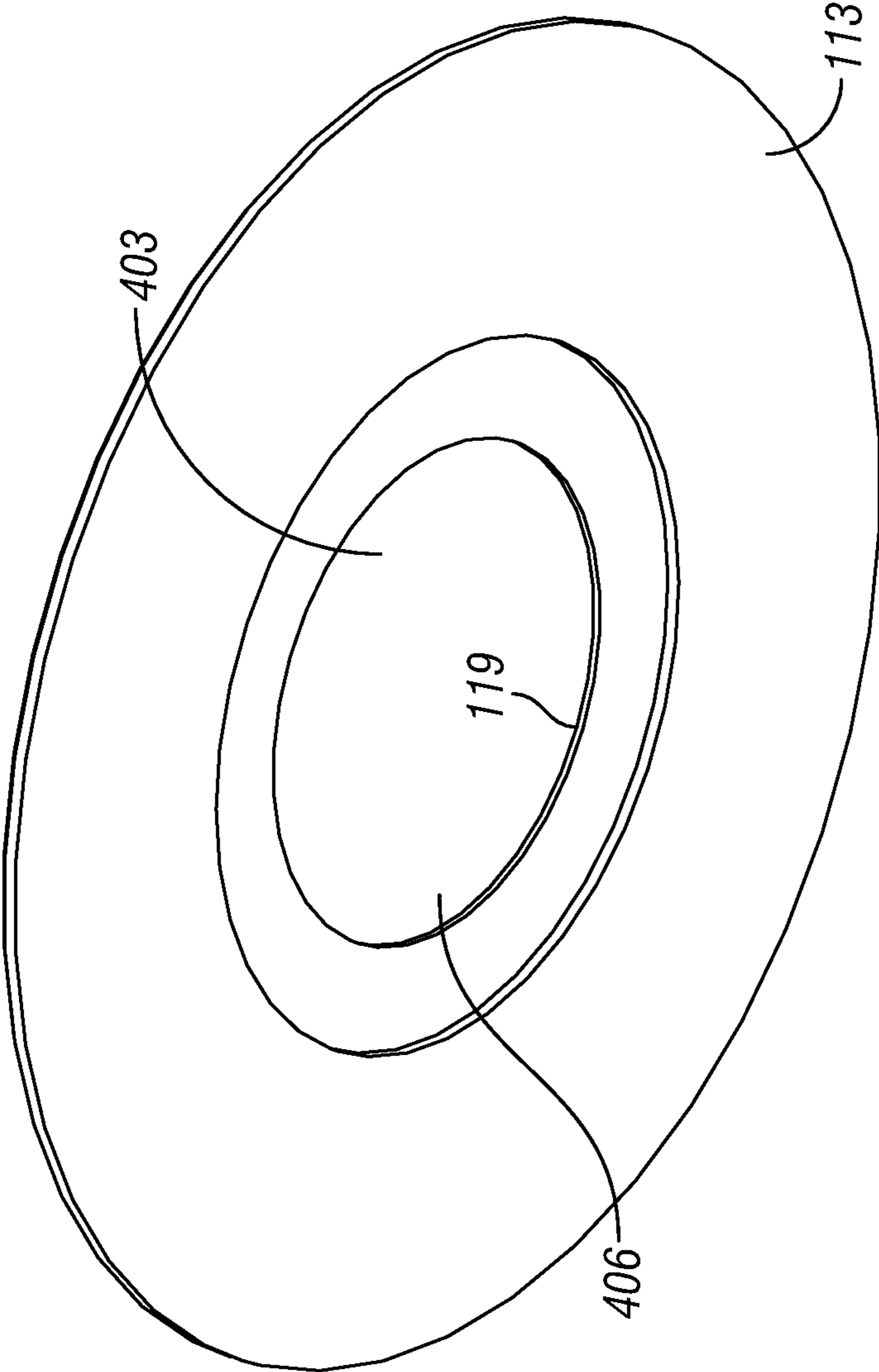


FIG. 13



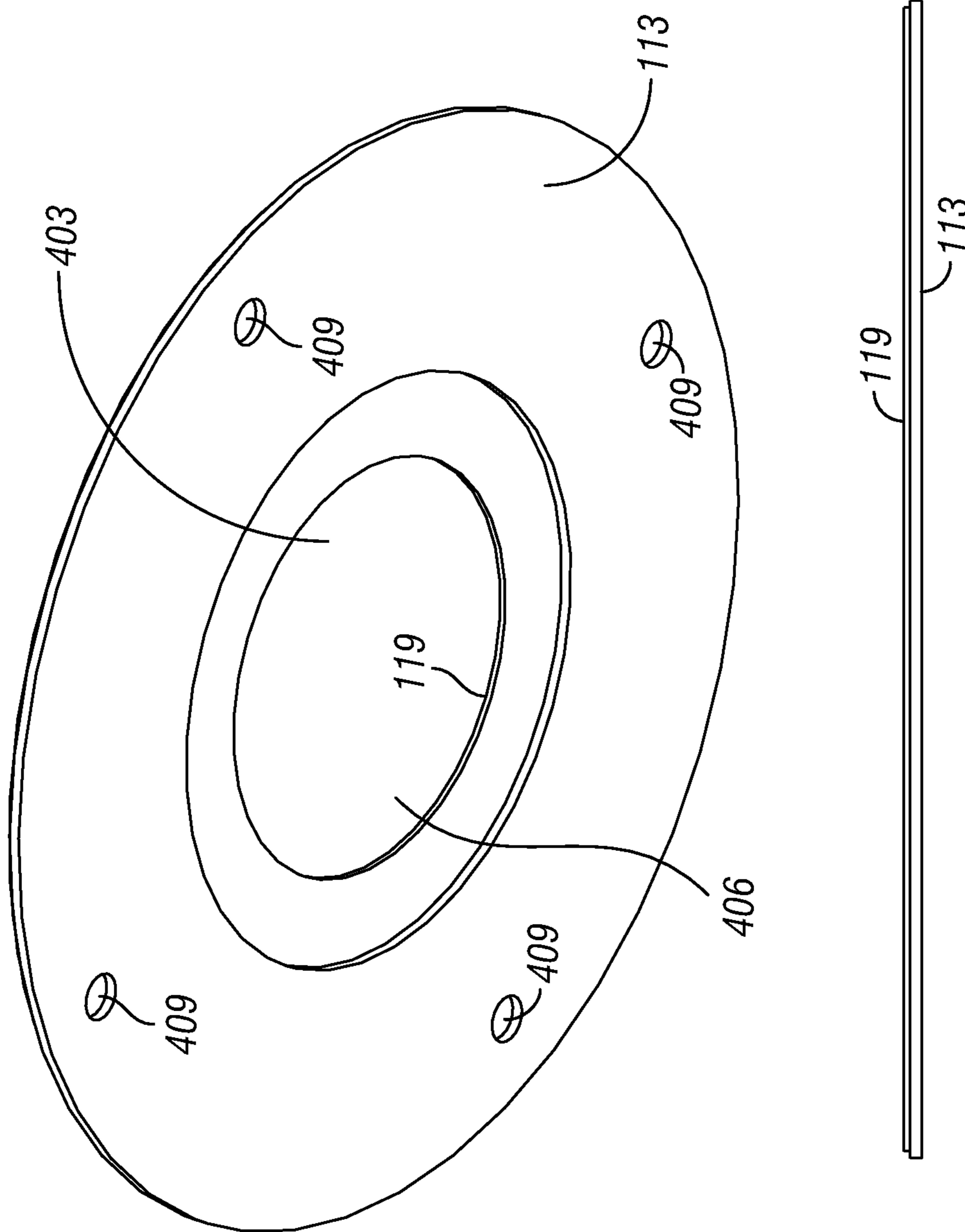


FIG. 14

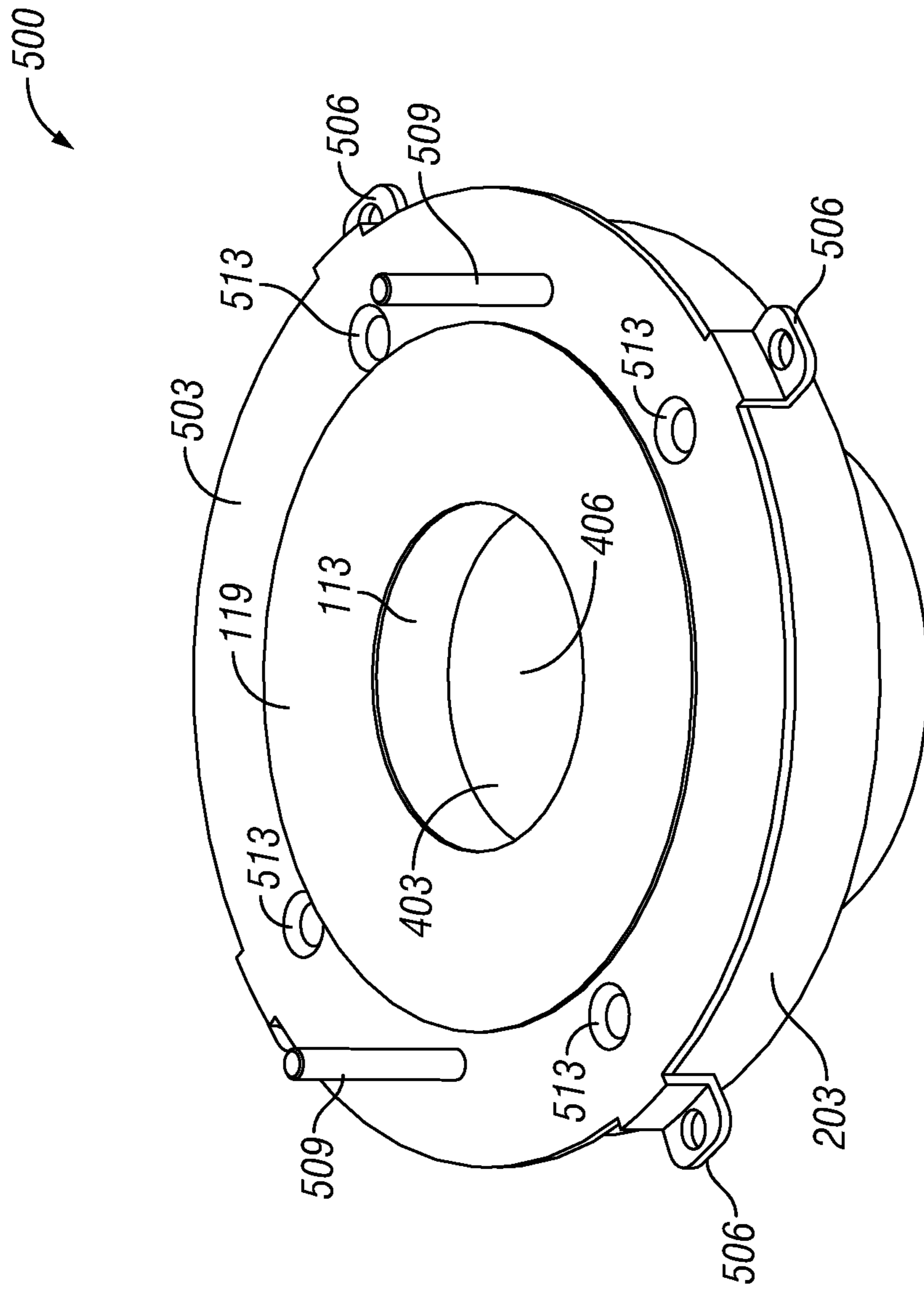


FIG. 15

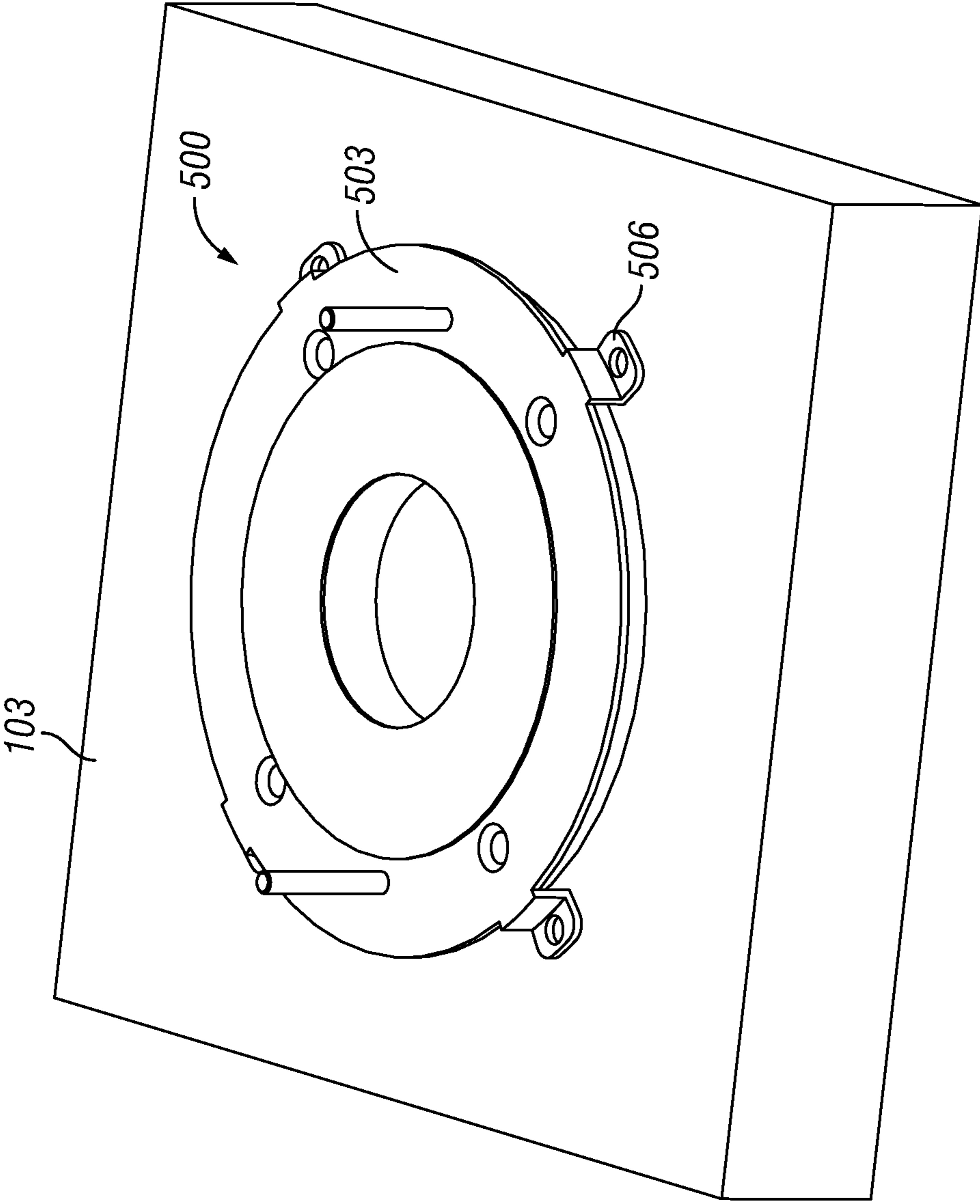


FIG. 16

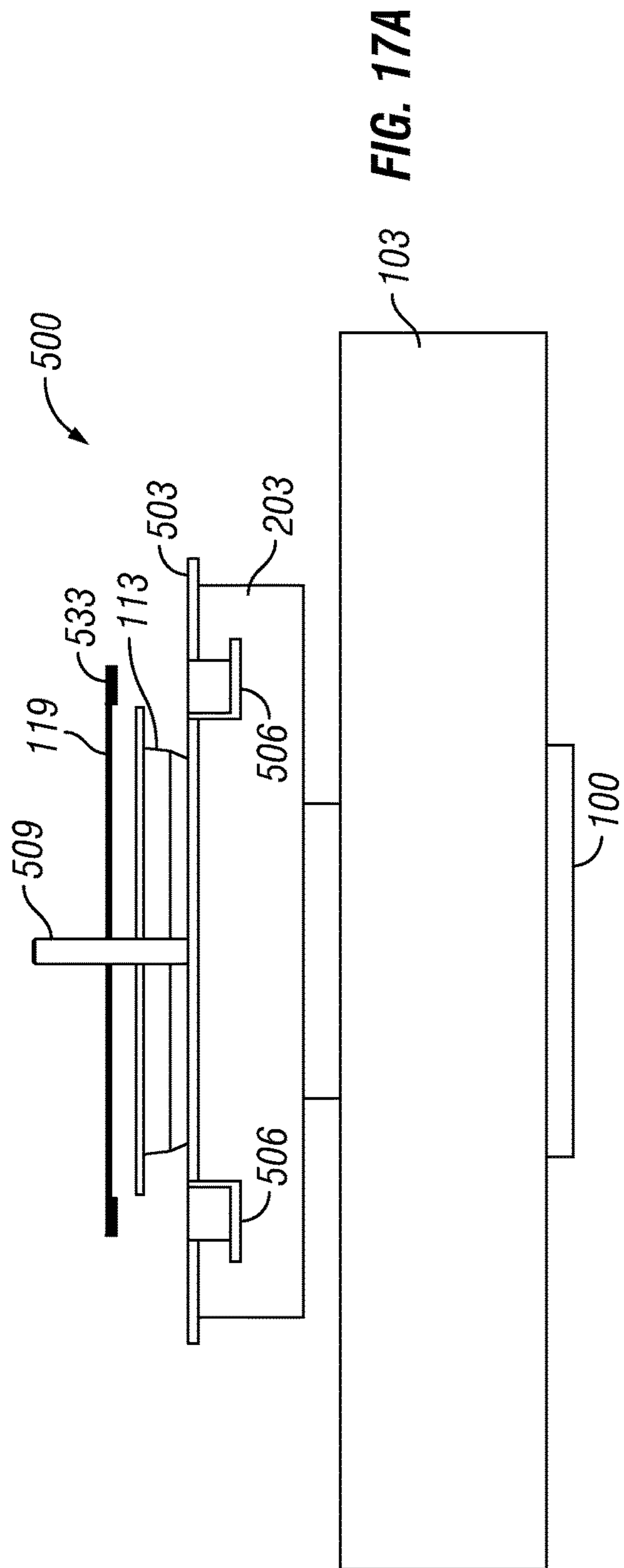


FIG. 17A

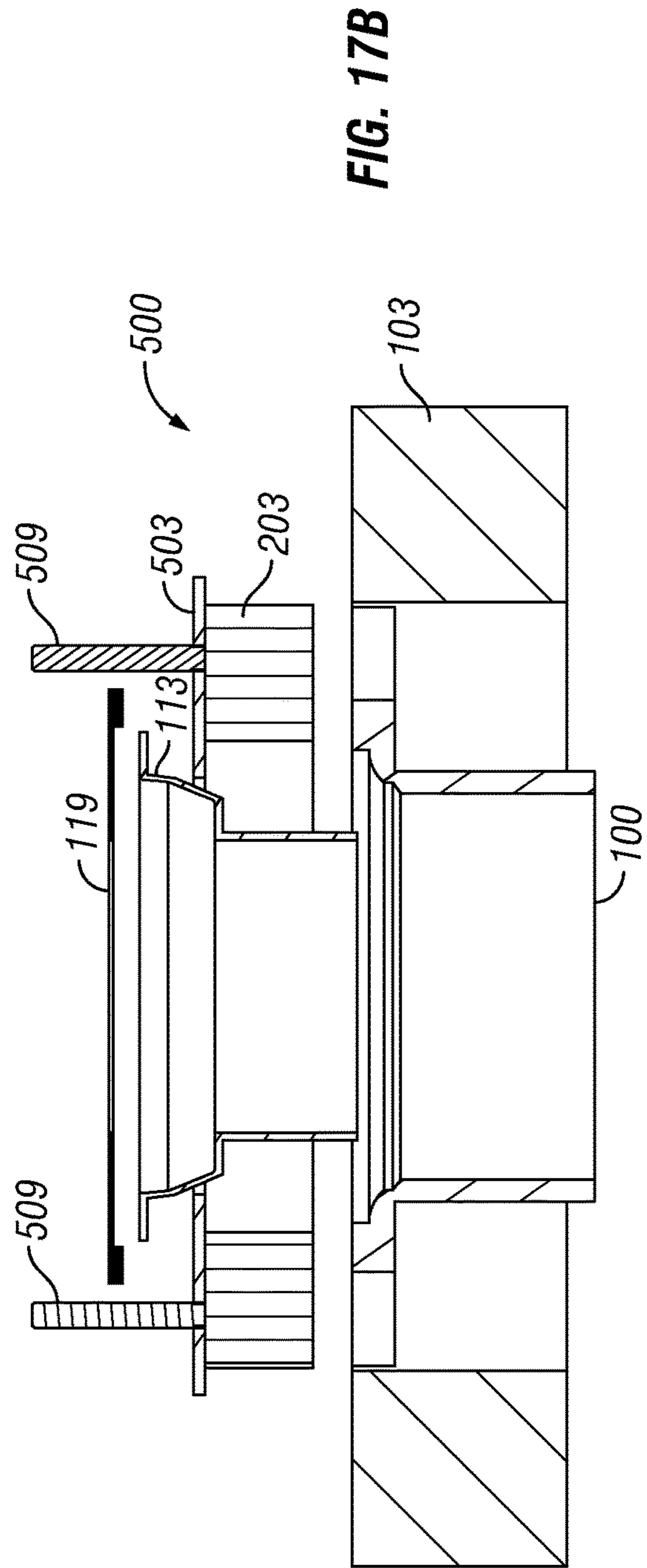


FIG. 17B



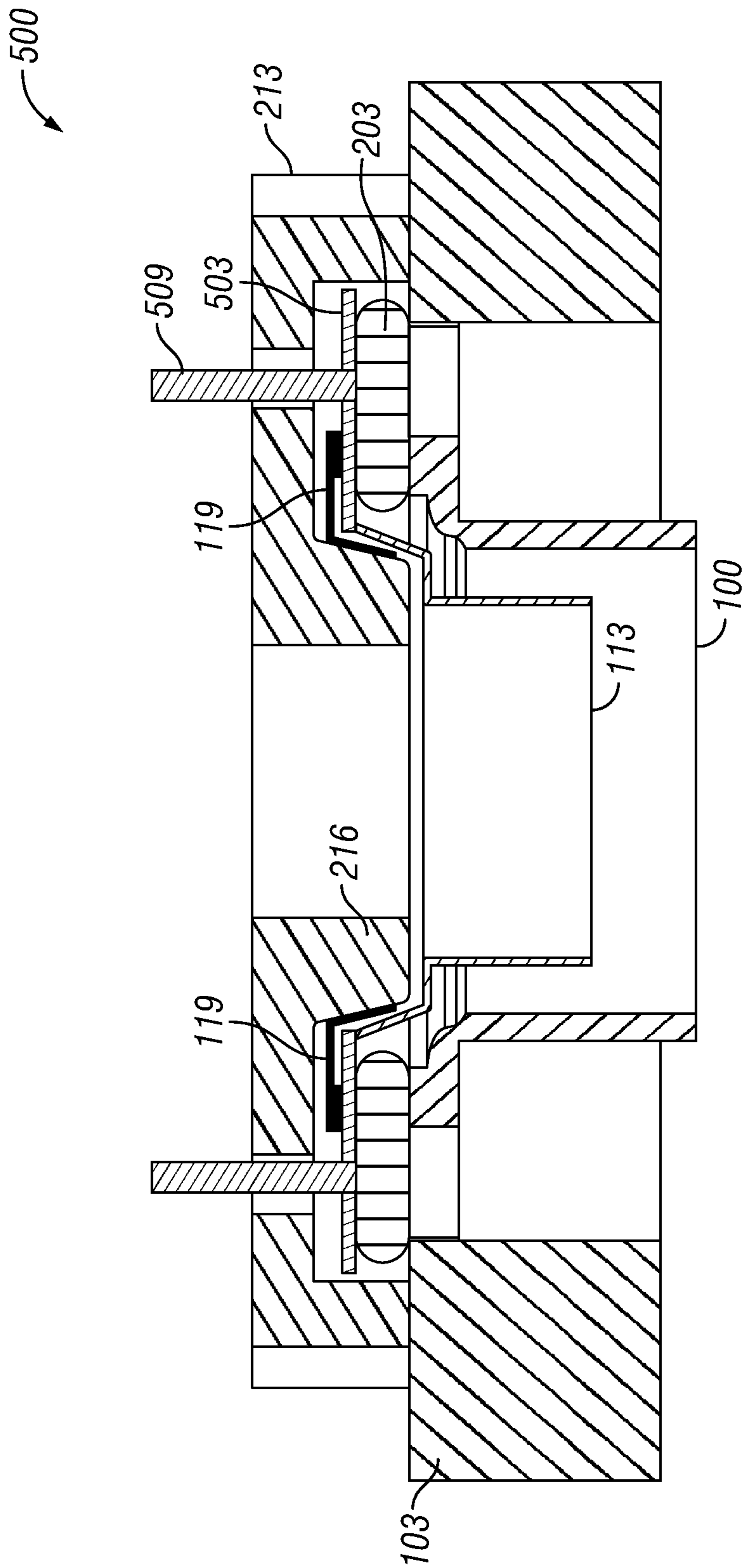


FIG. 18

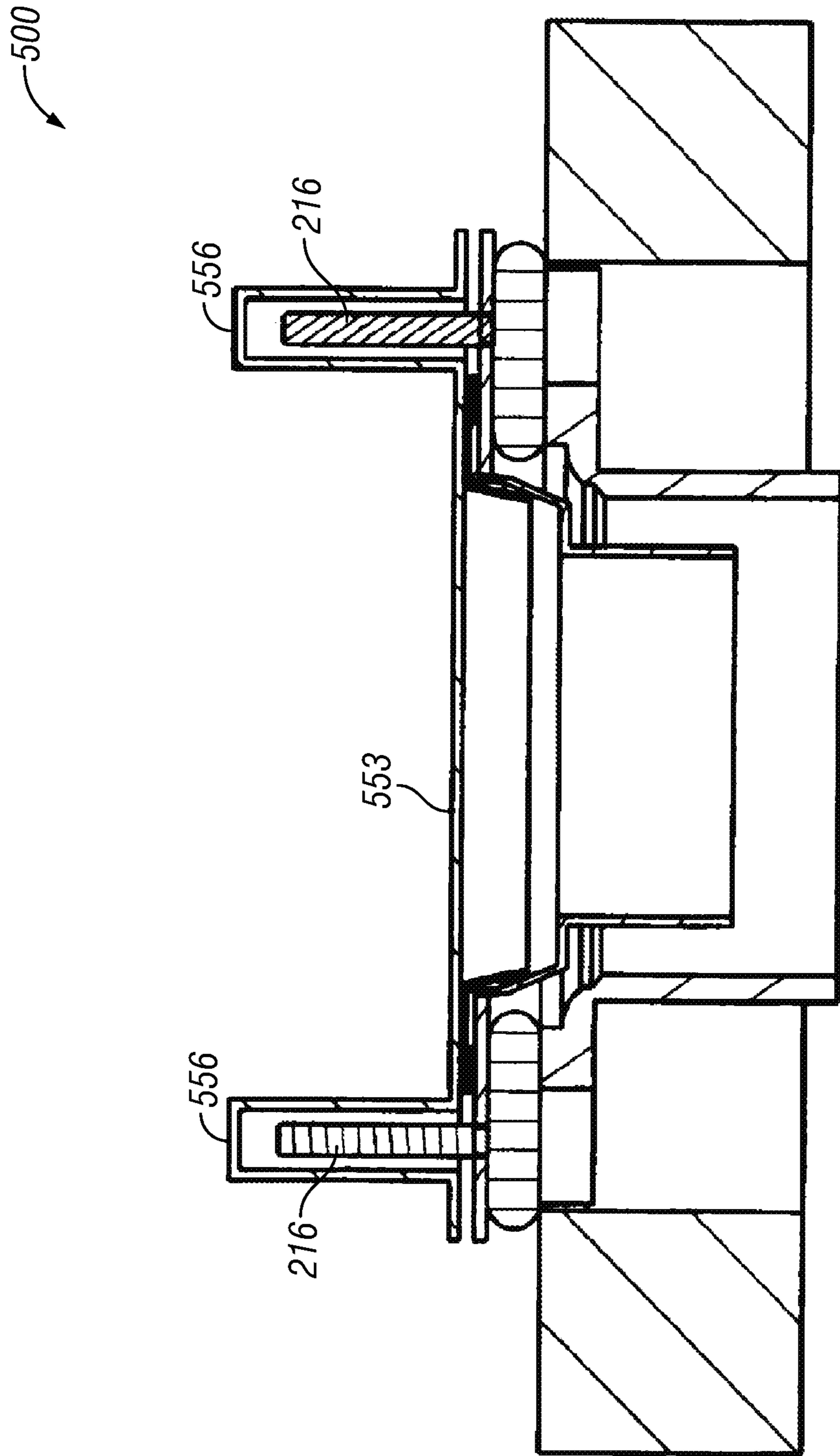


FIG. 19

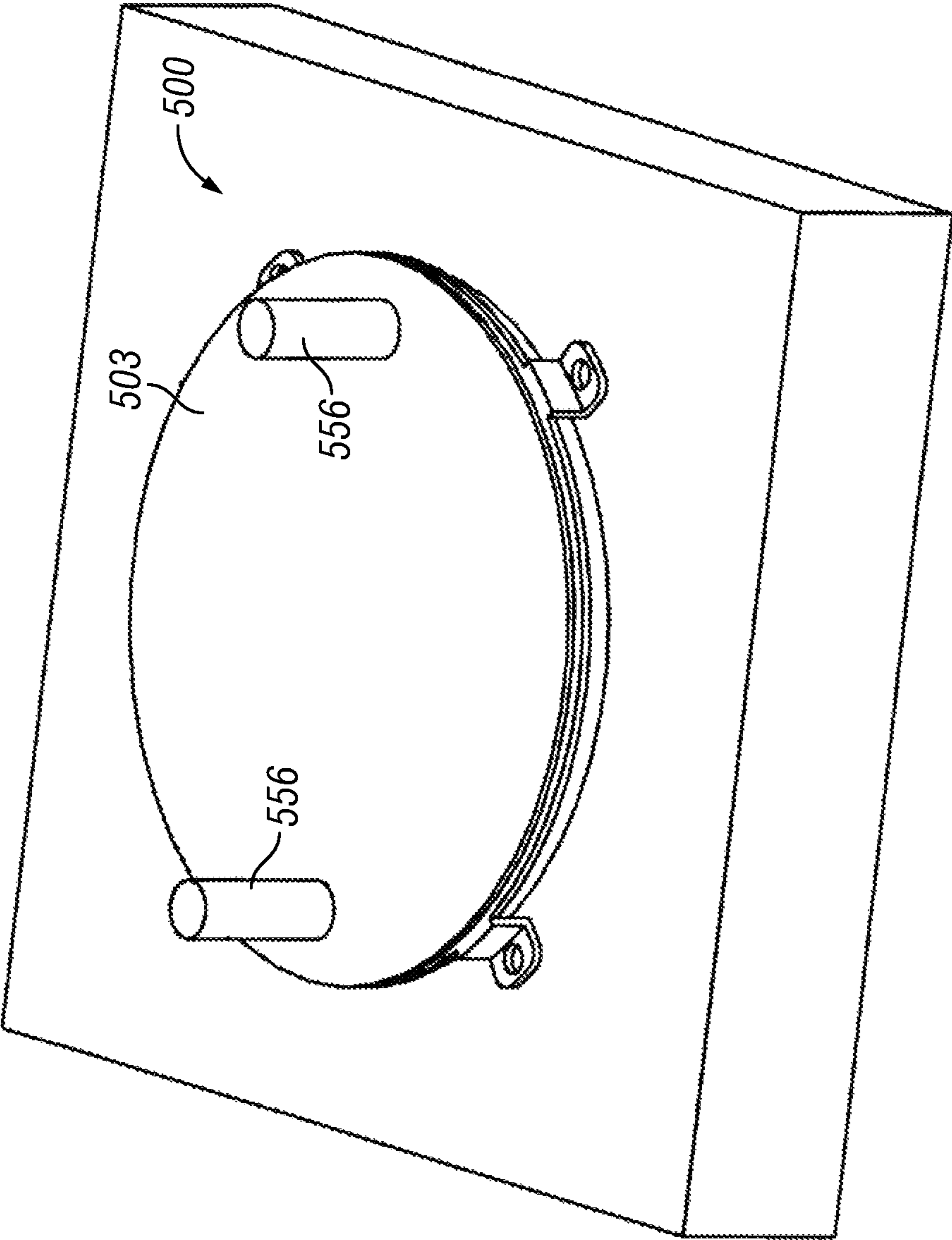


FIG. 20

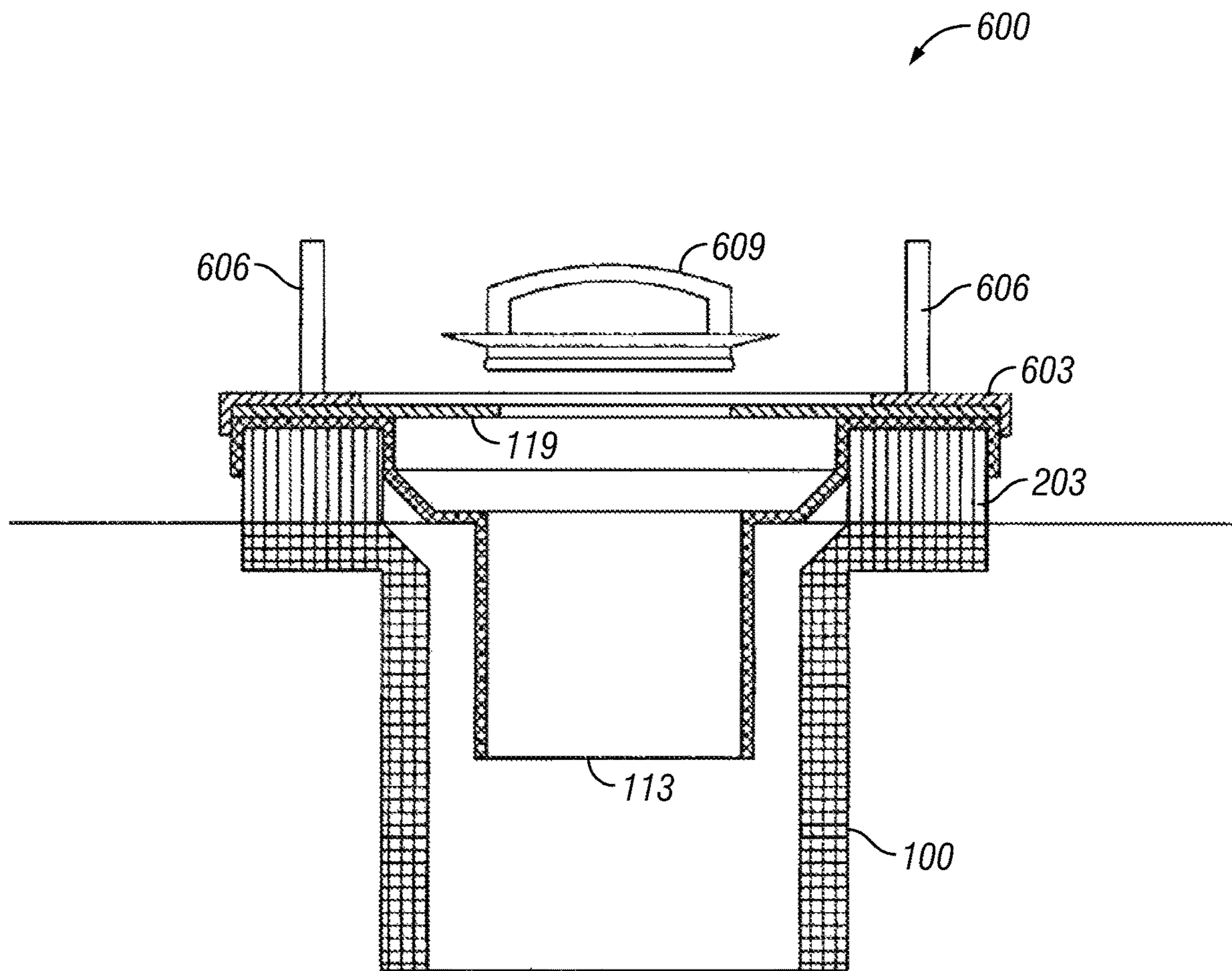
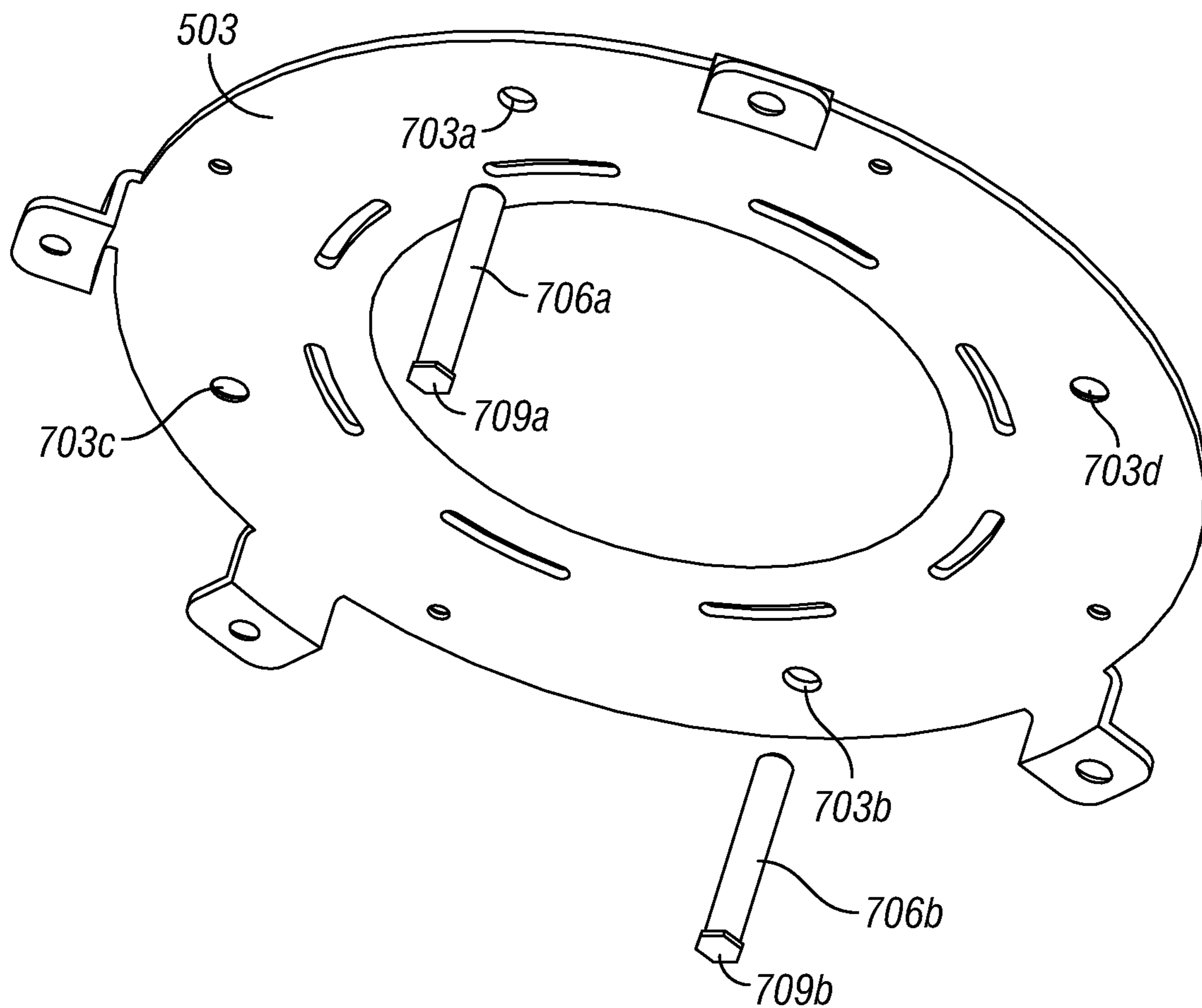
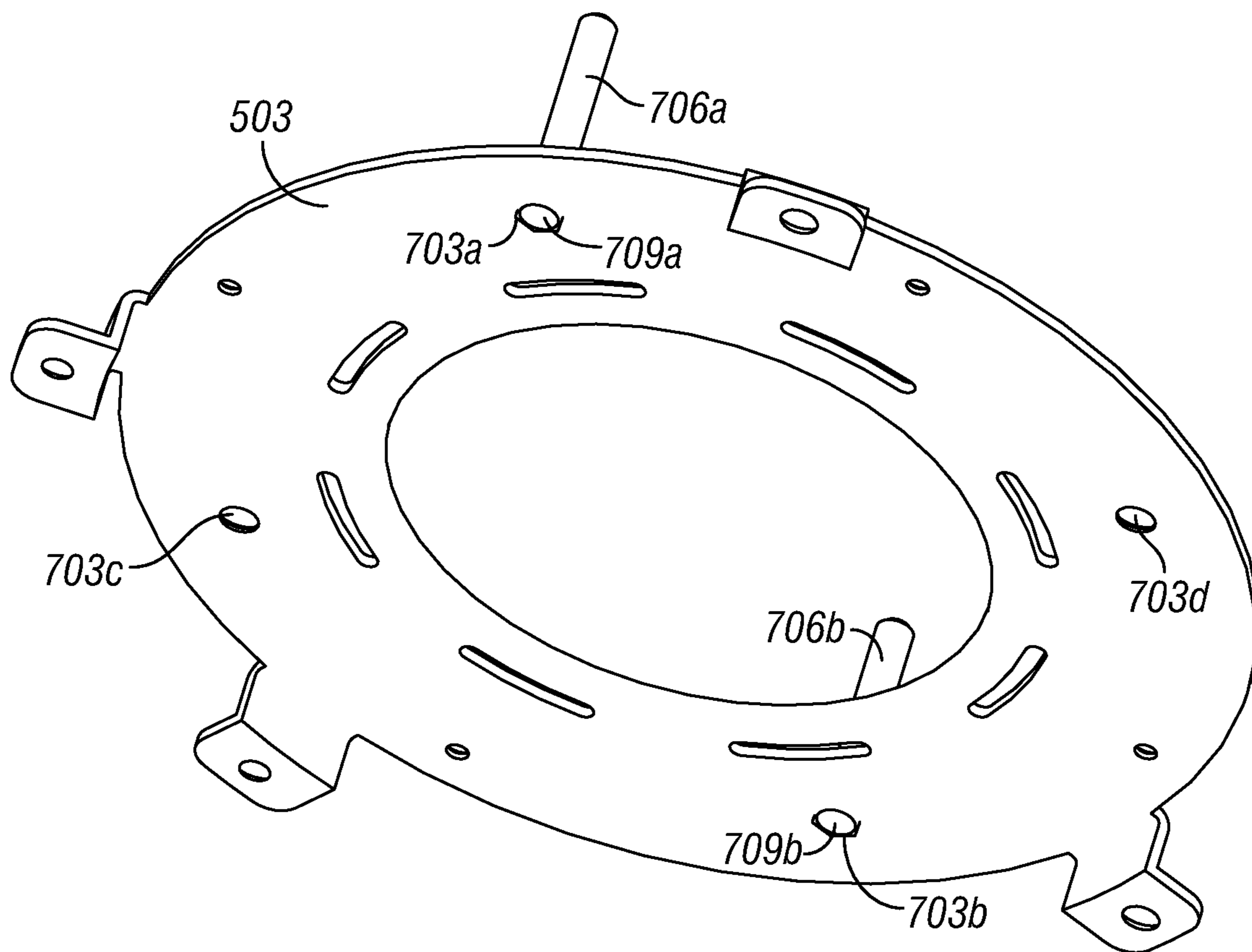


FIG. 21

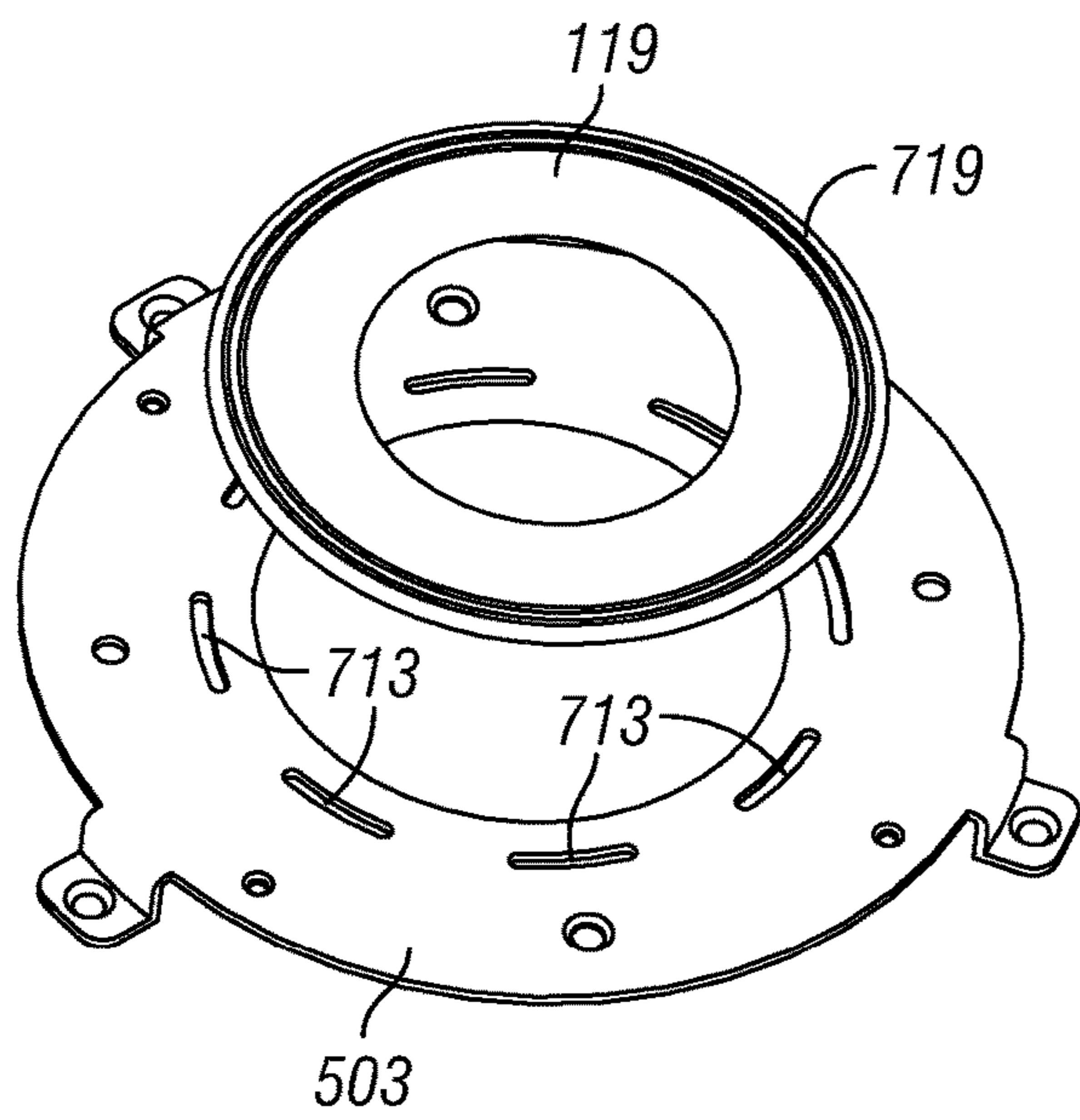




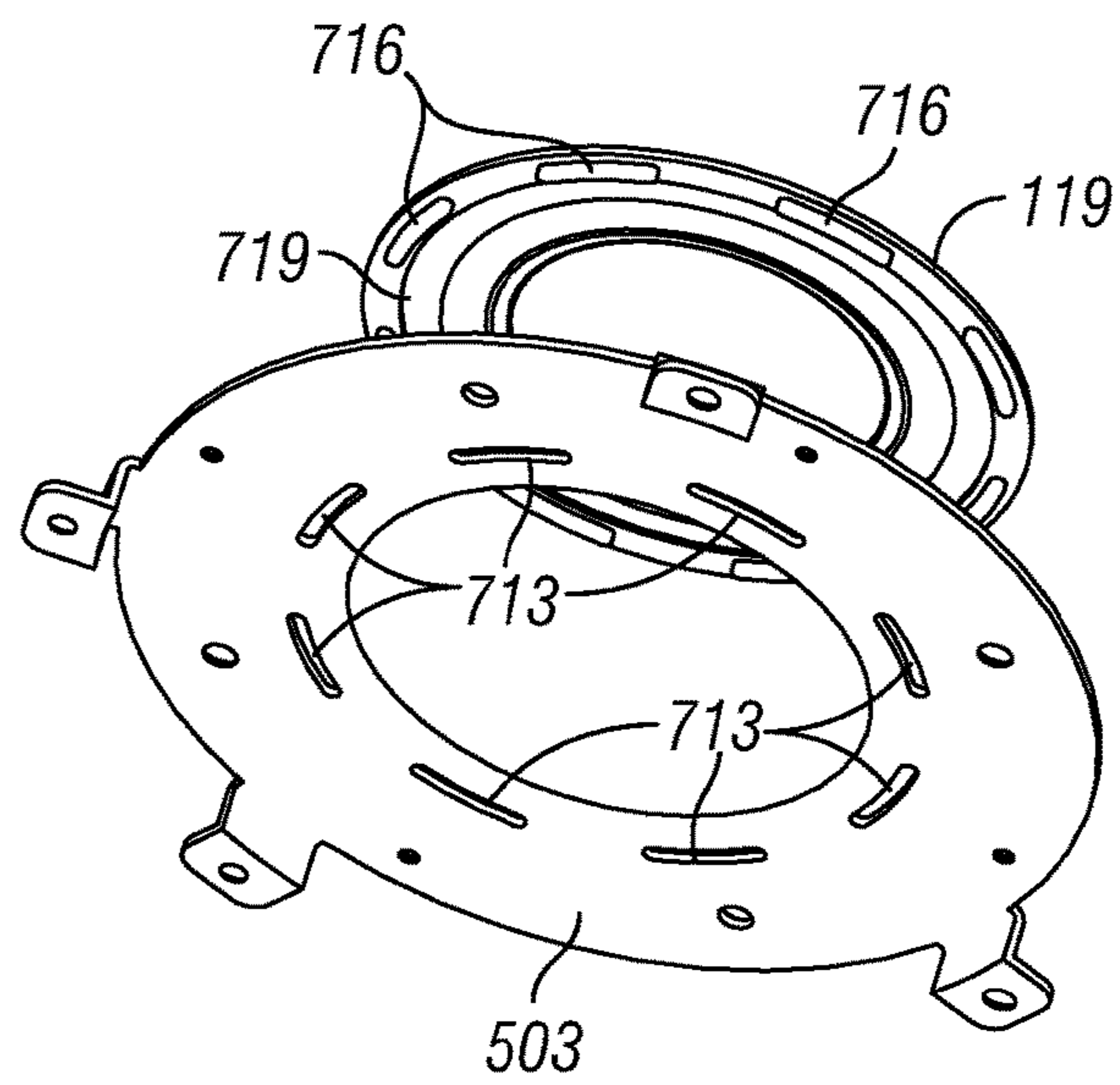
**FIG. 22A**



**FIG. 22B**



**FIG. 23A**



**FIG. 23B**

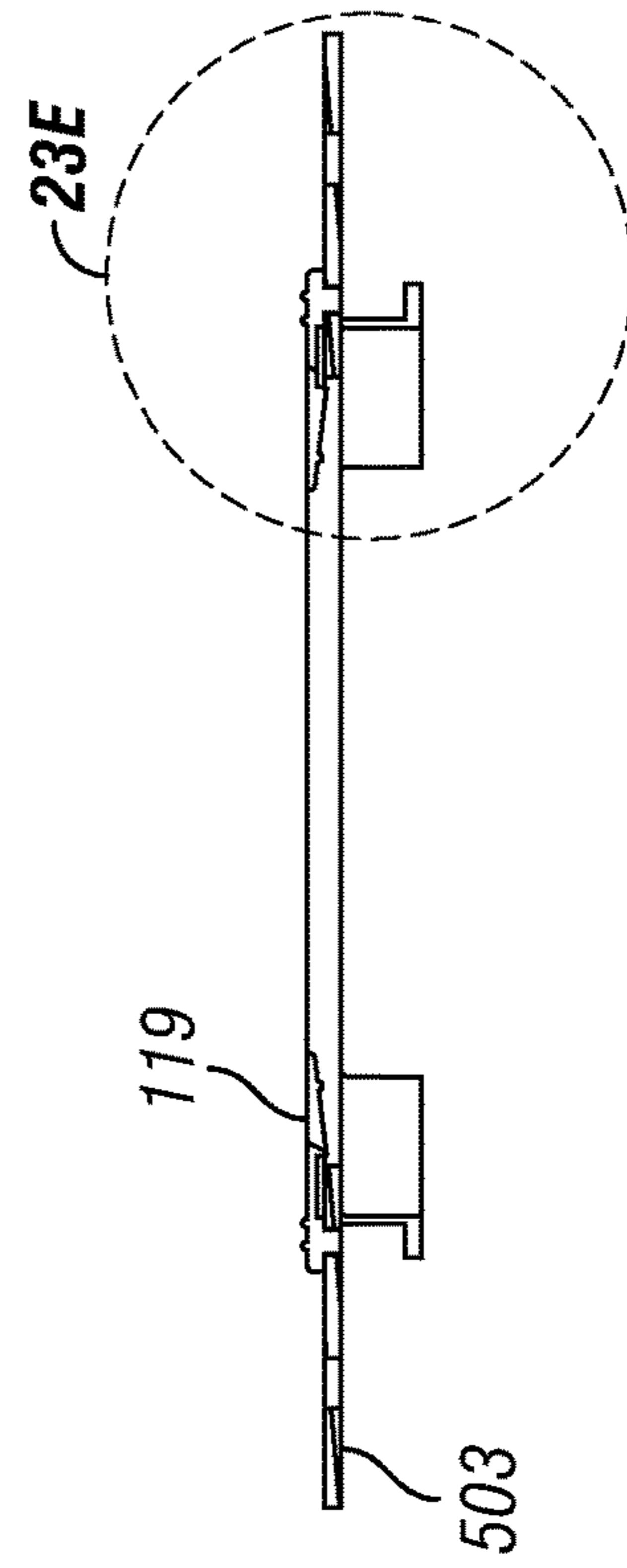
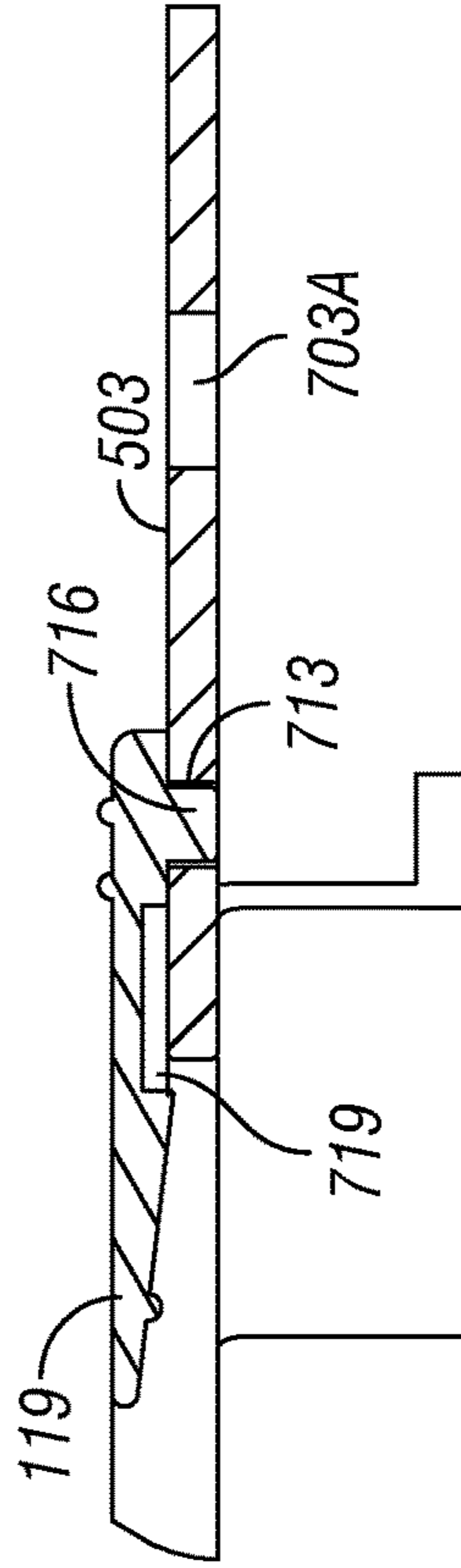
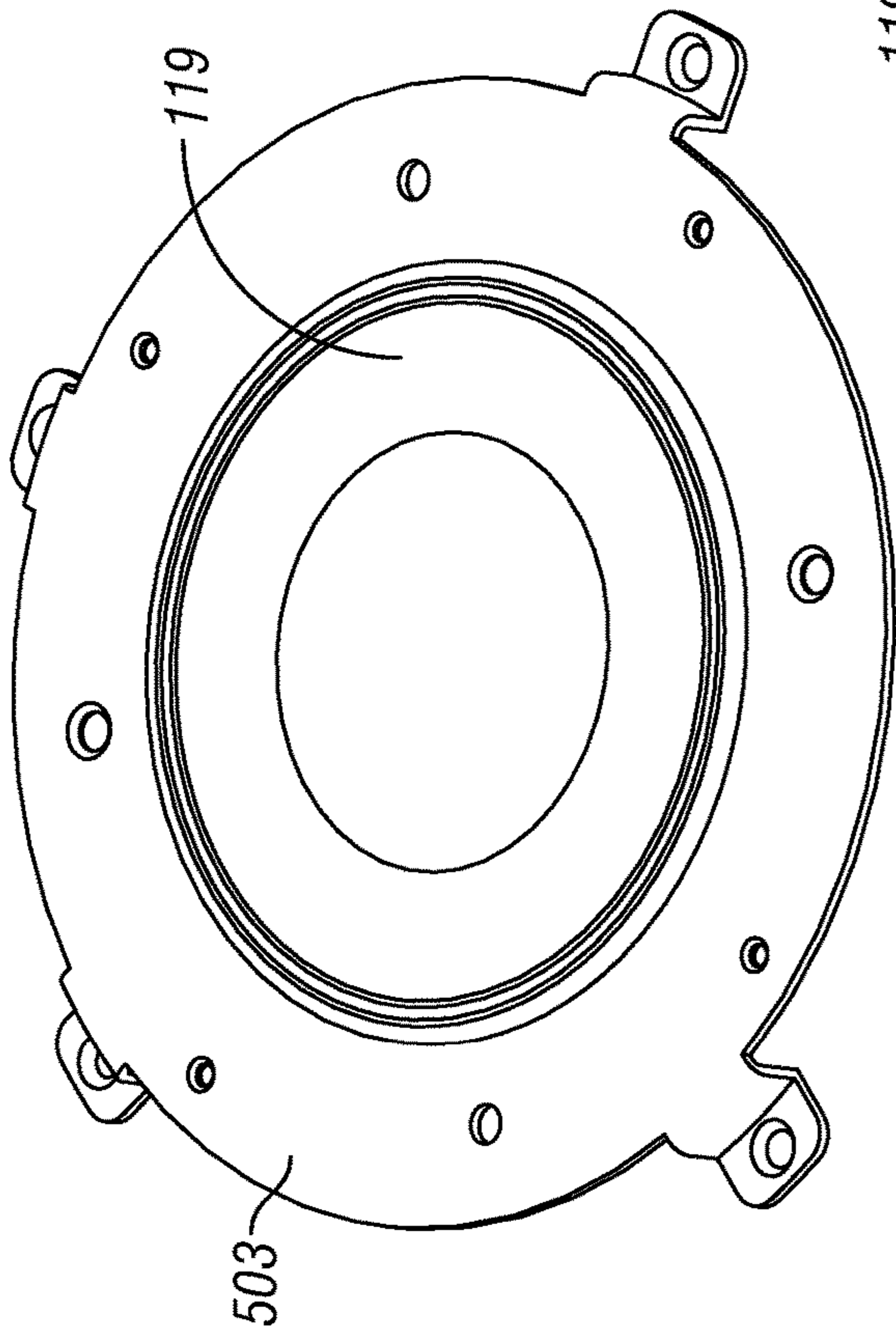


FIG. 23C

FIG. 23E

FIG. 23D



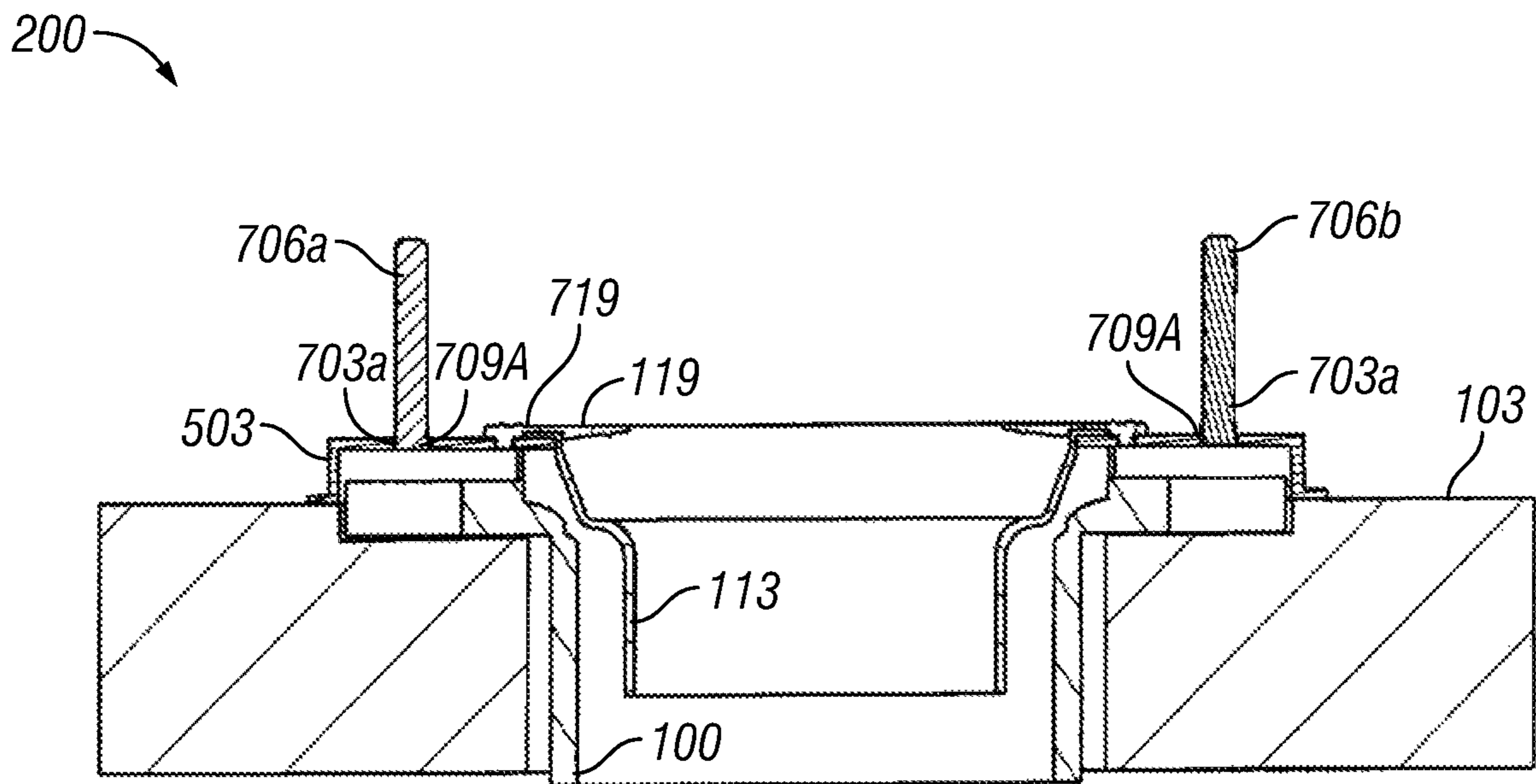
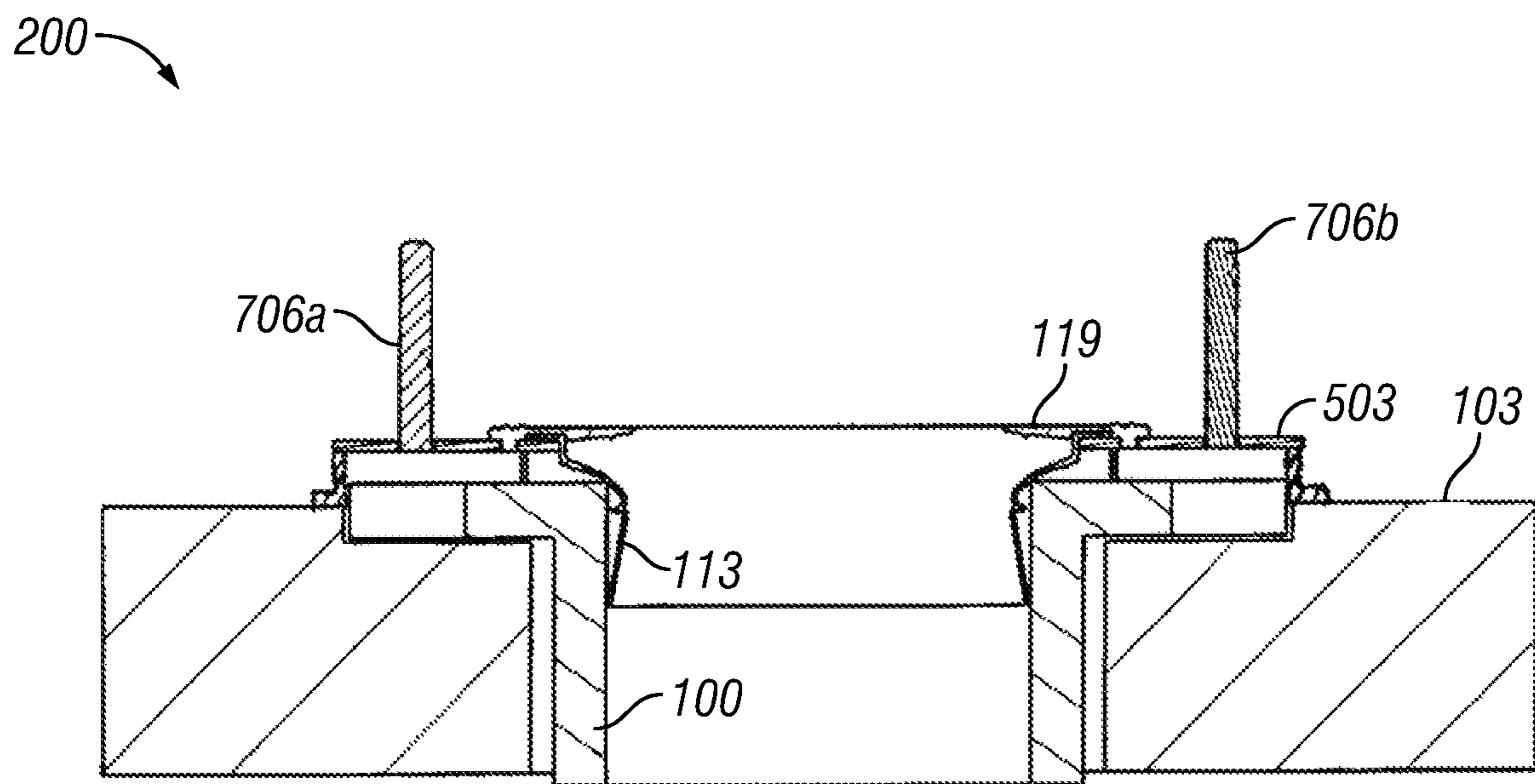
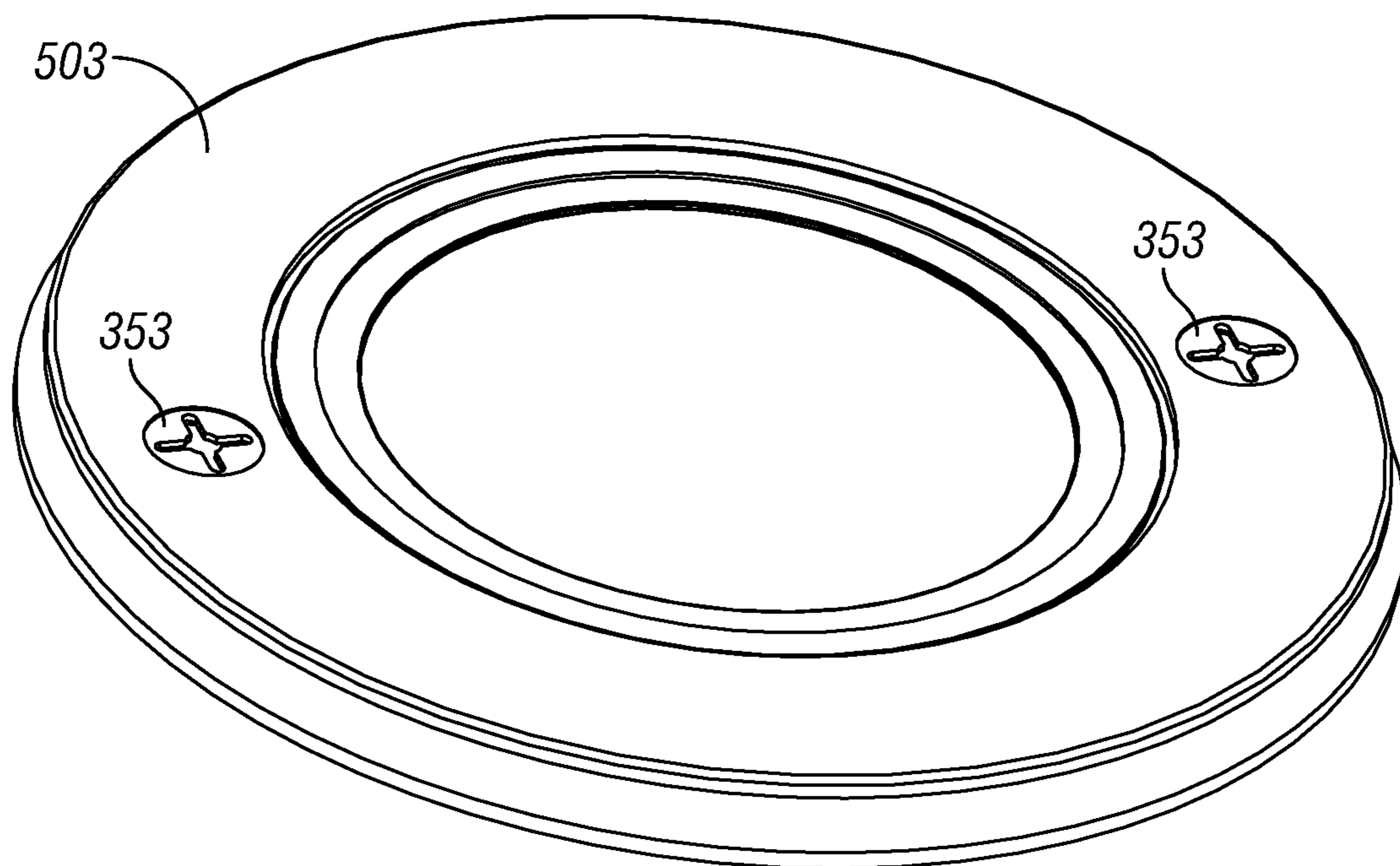


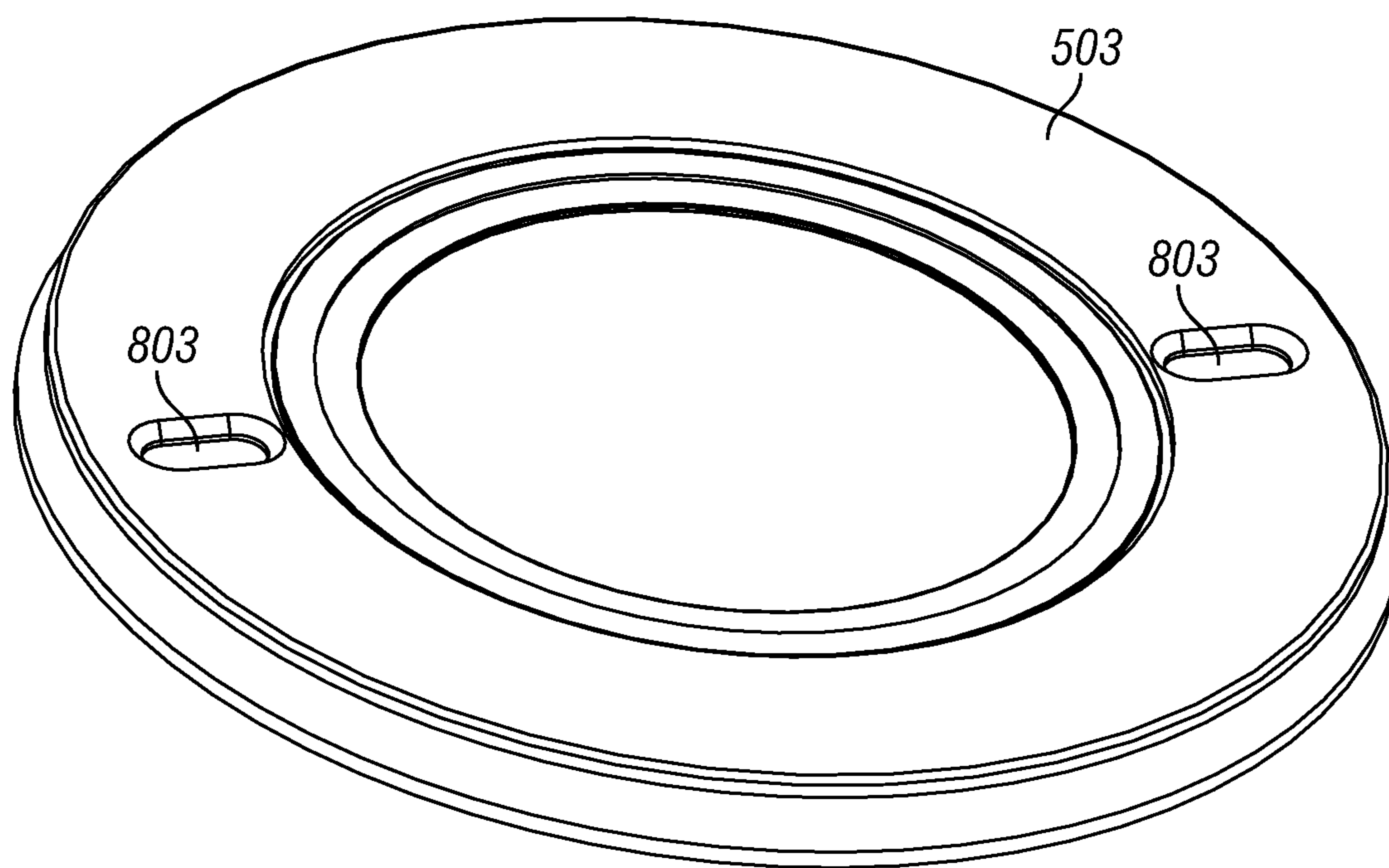
FIG. 24A



**FIG. 24B**

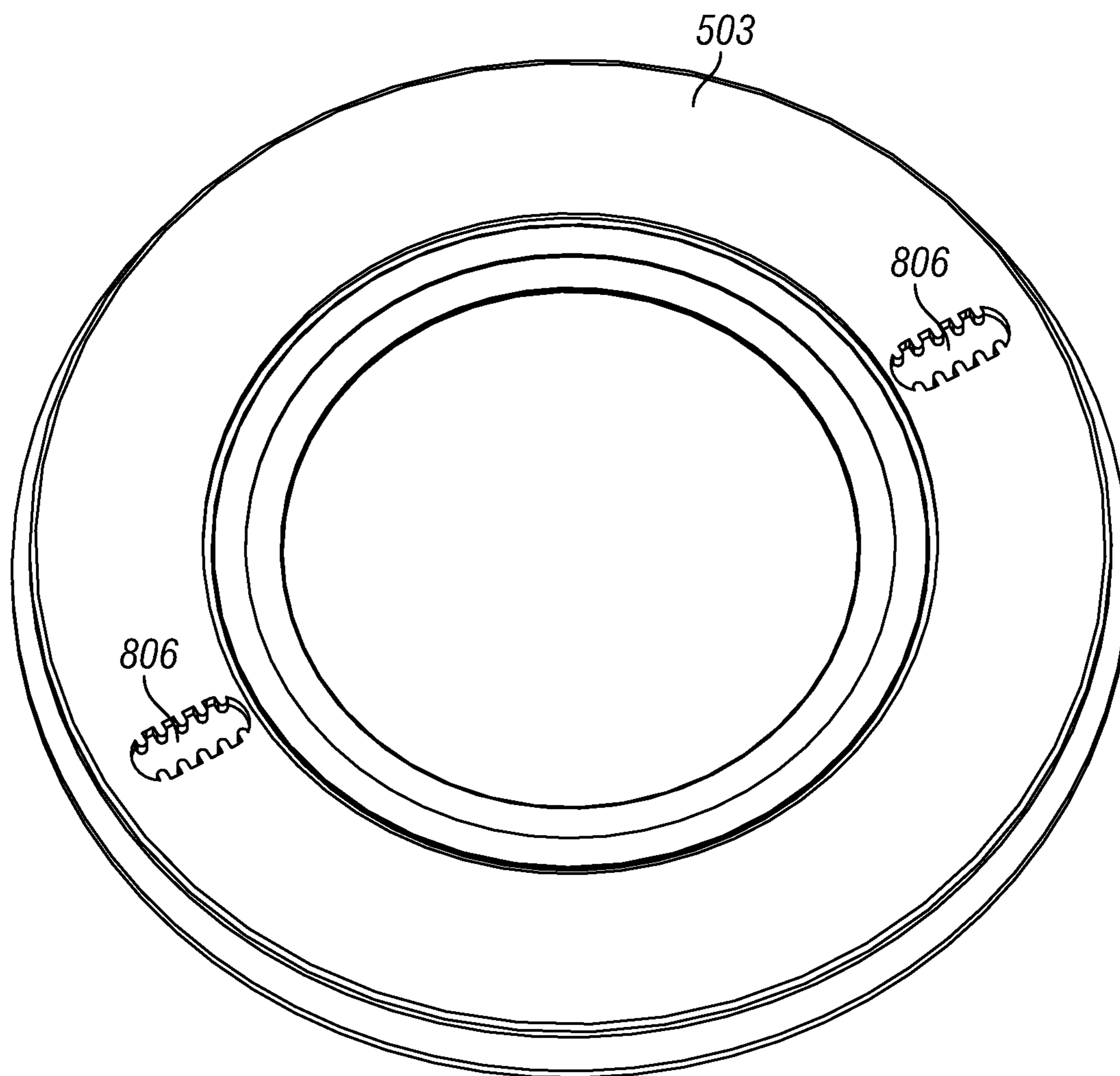


**FIG. 25A**

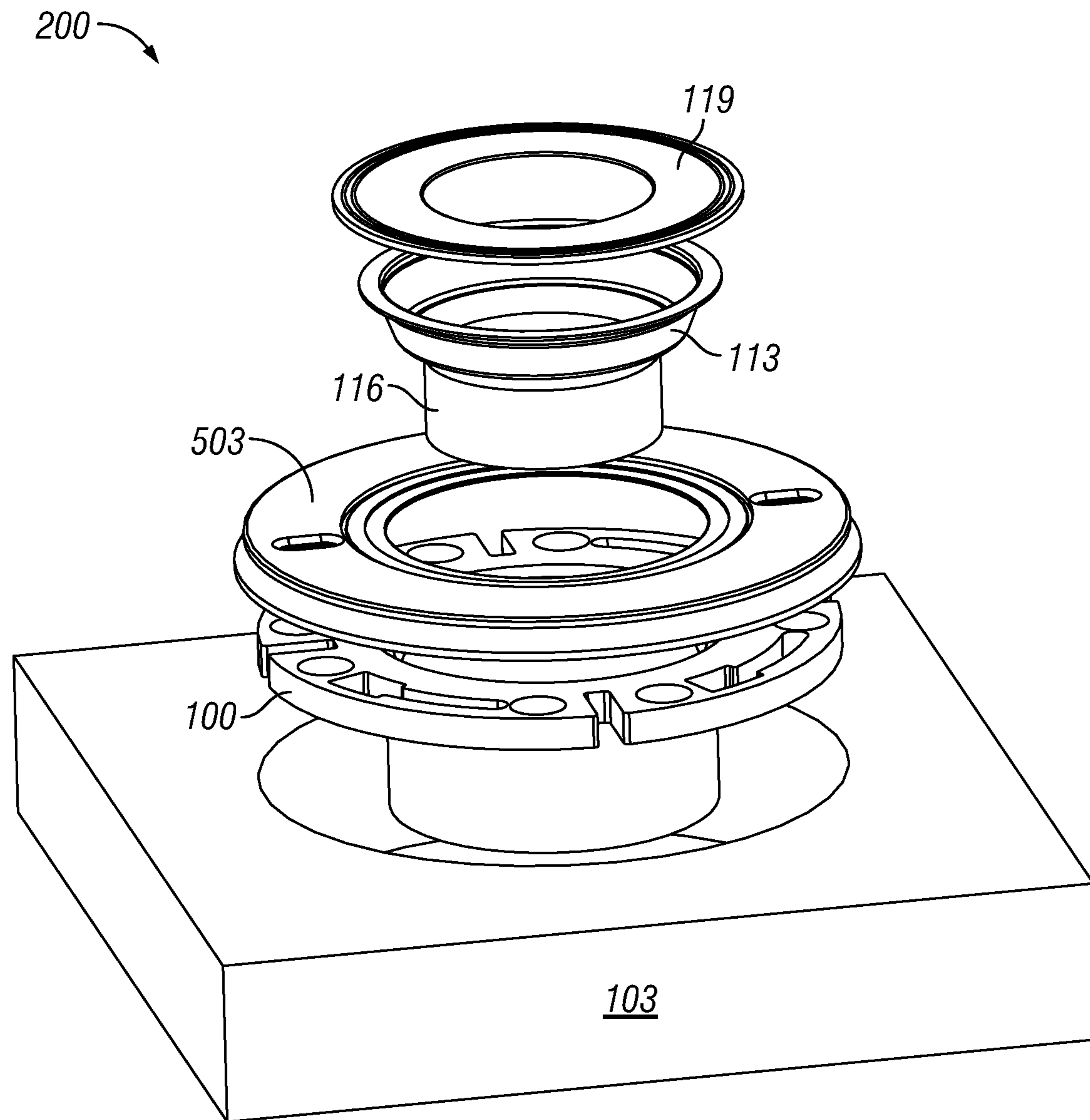


**FIG. 25B**

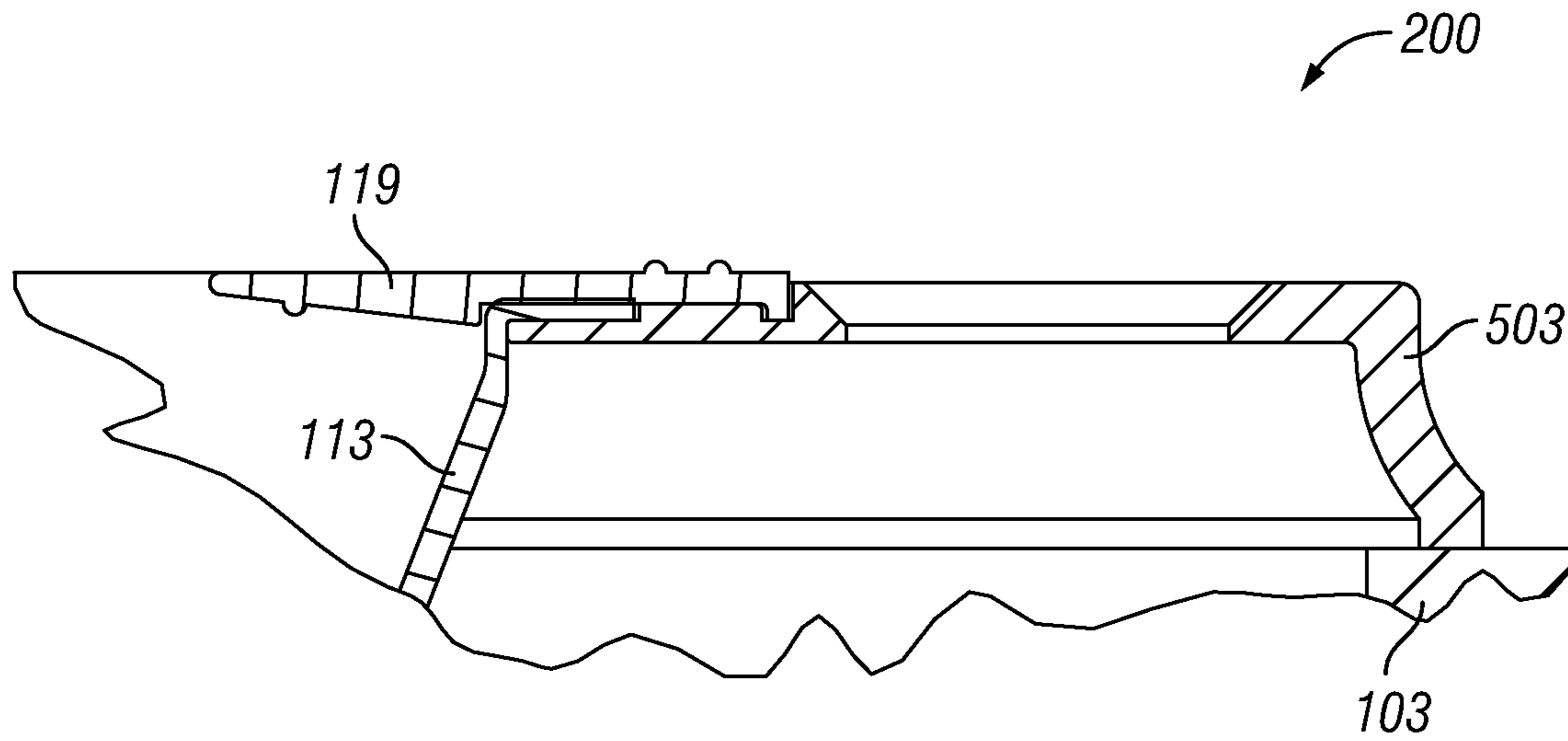




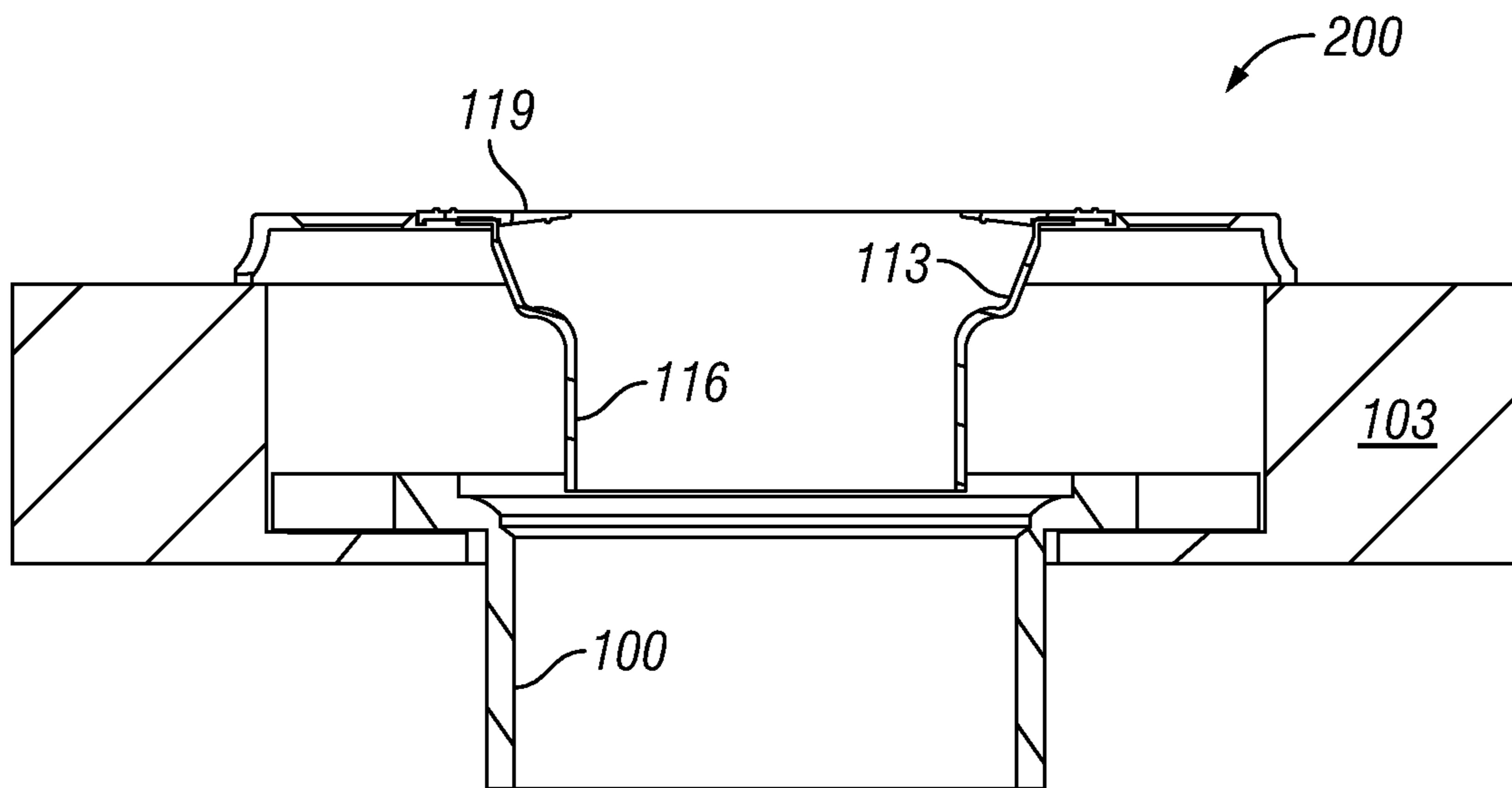
**FIG. 25C**



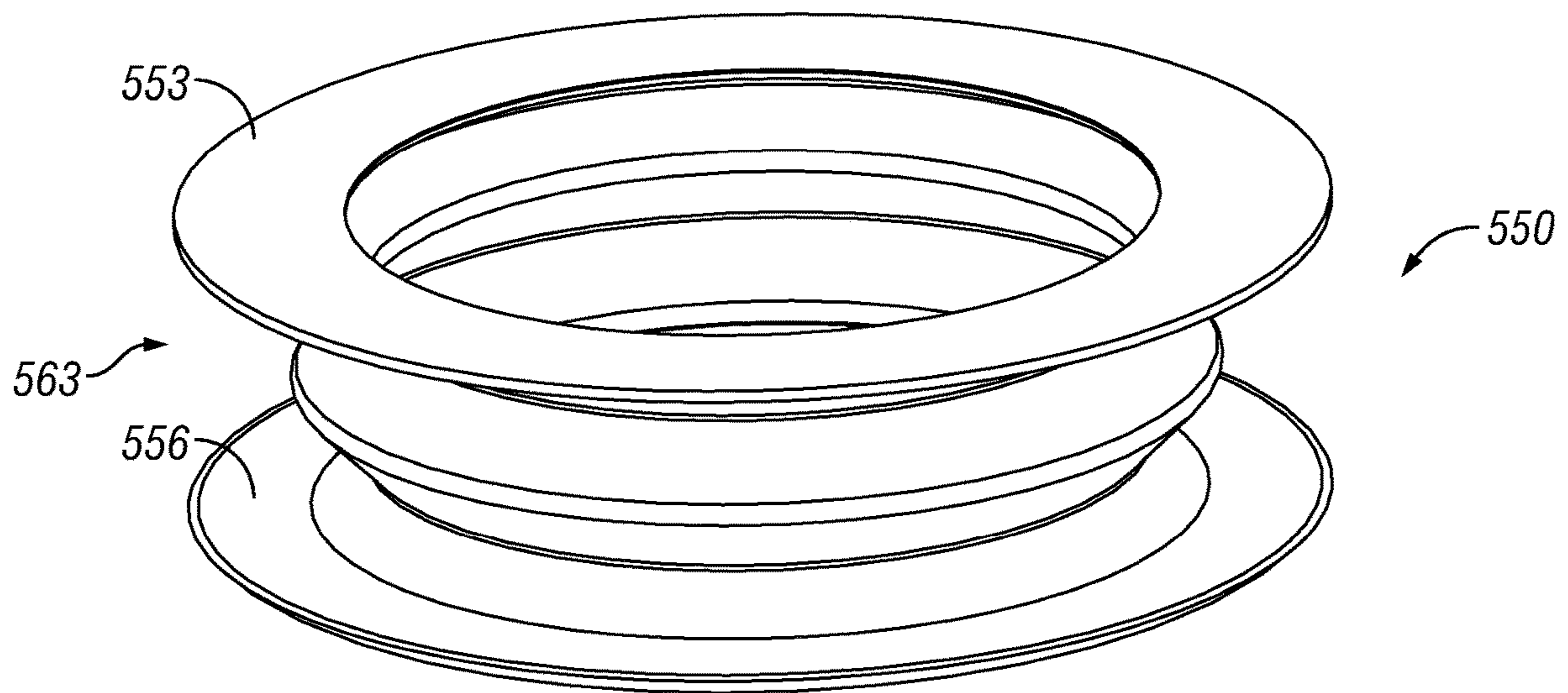
**FIG. 26A**



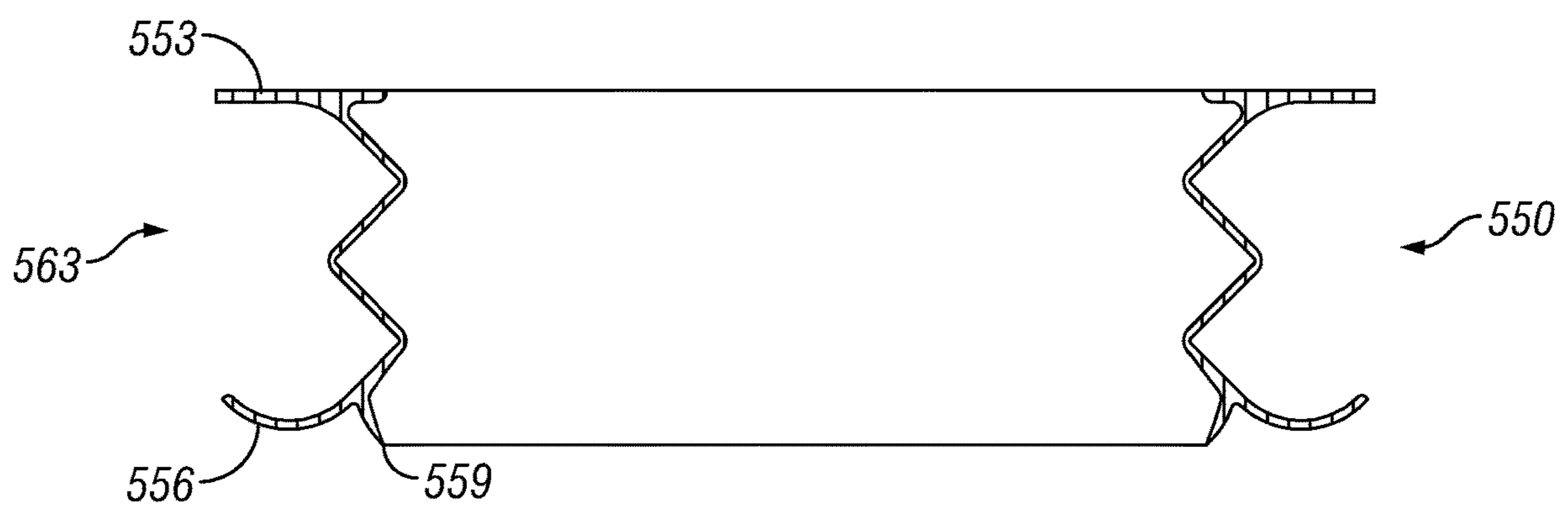
**FIG. 26B**



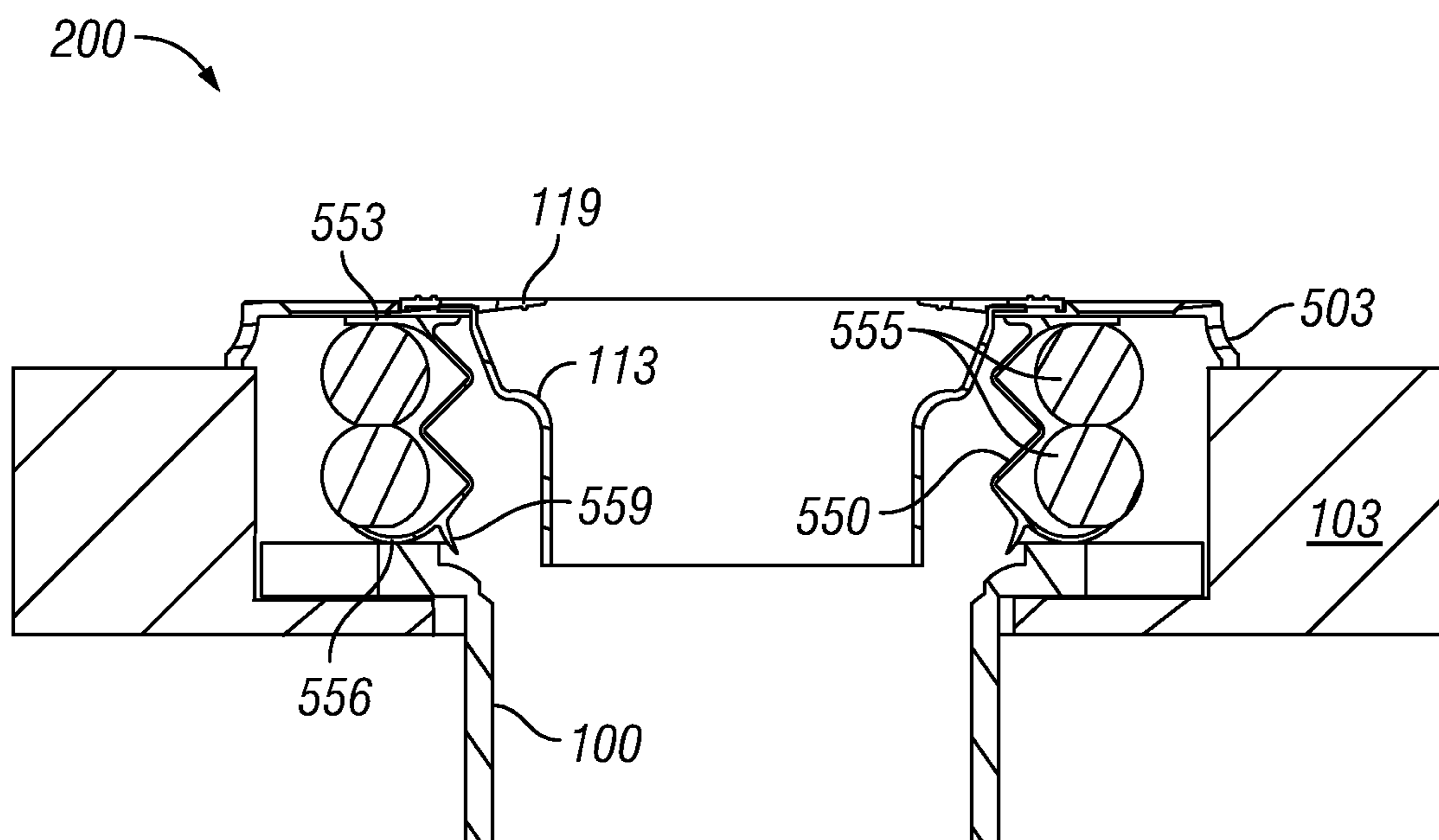
**FIG. 26C**



**FIG. 27A**

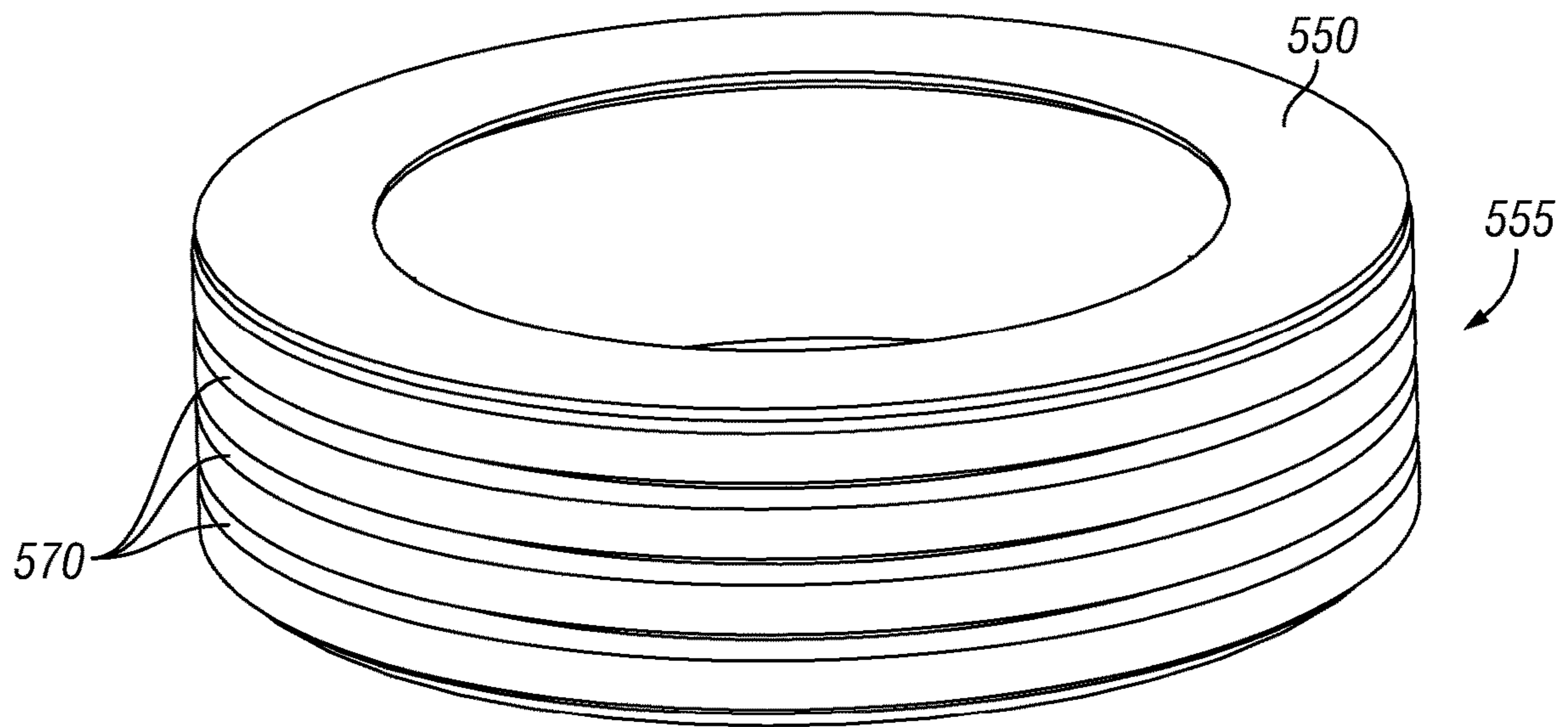


**FIG. 27B**



**FIG. 27C**





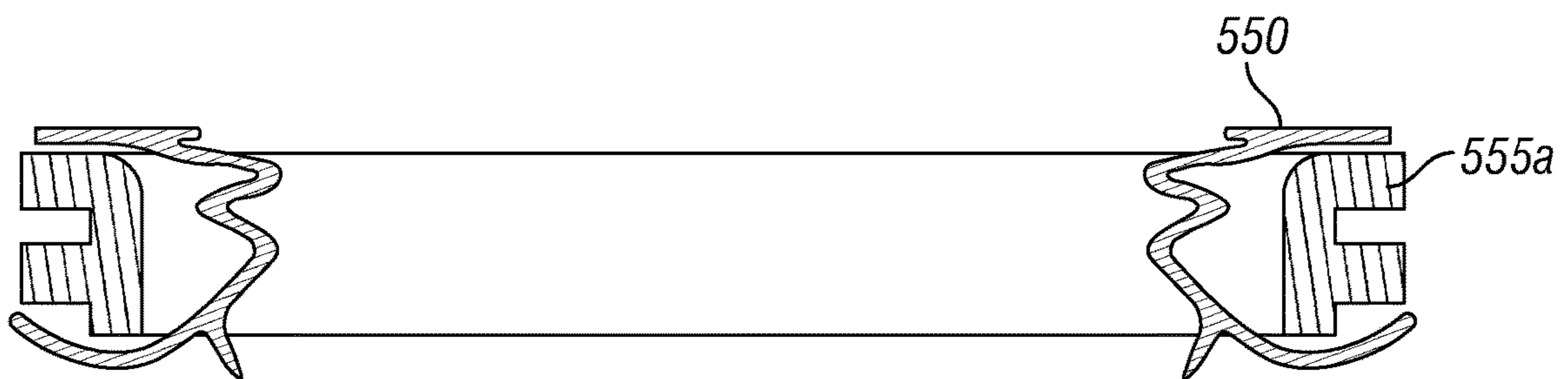
**FIG. 28A**



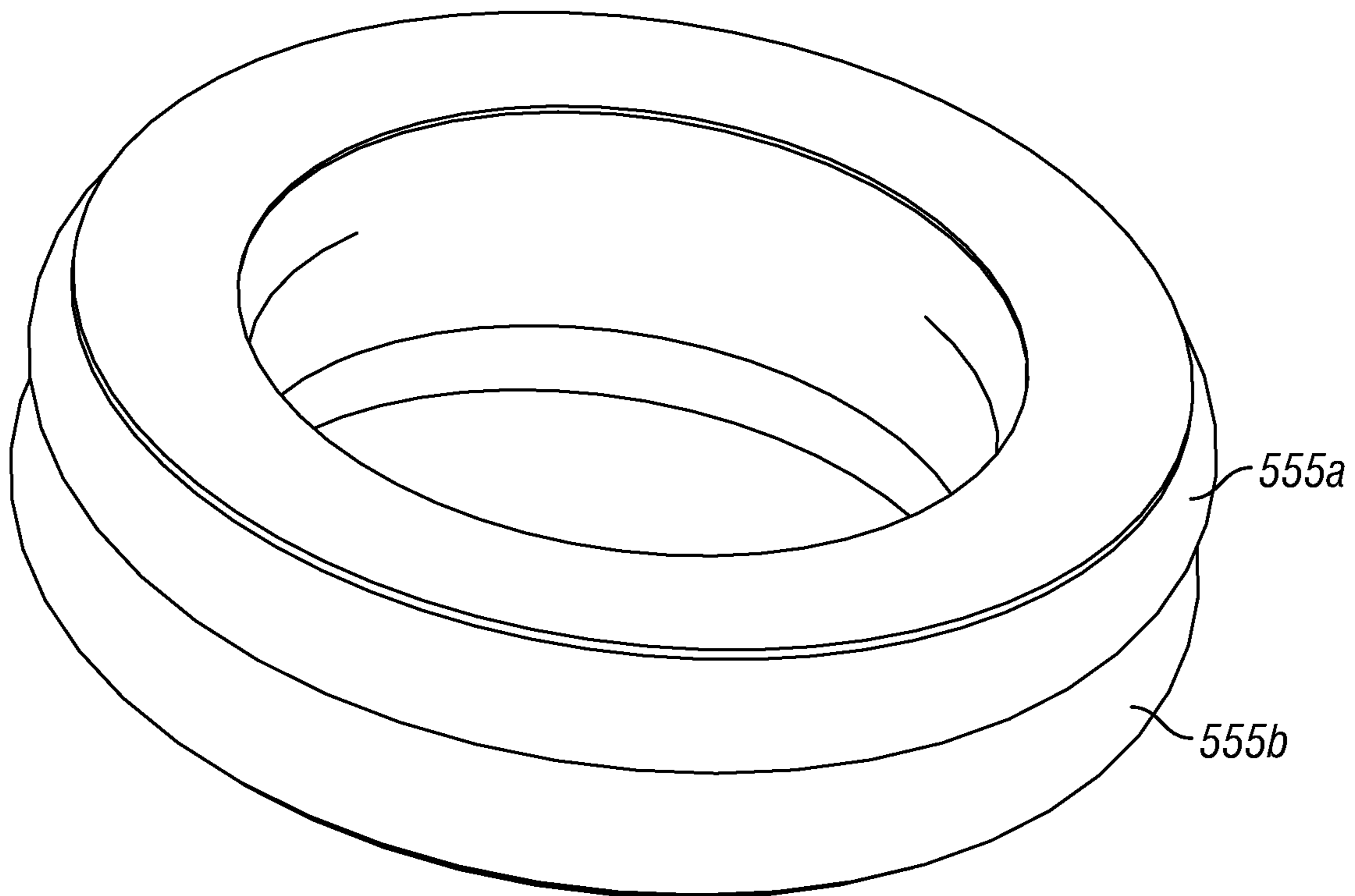
**FIG. 28B**



**FIG. 29A**



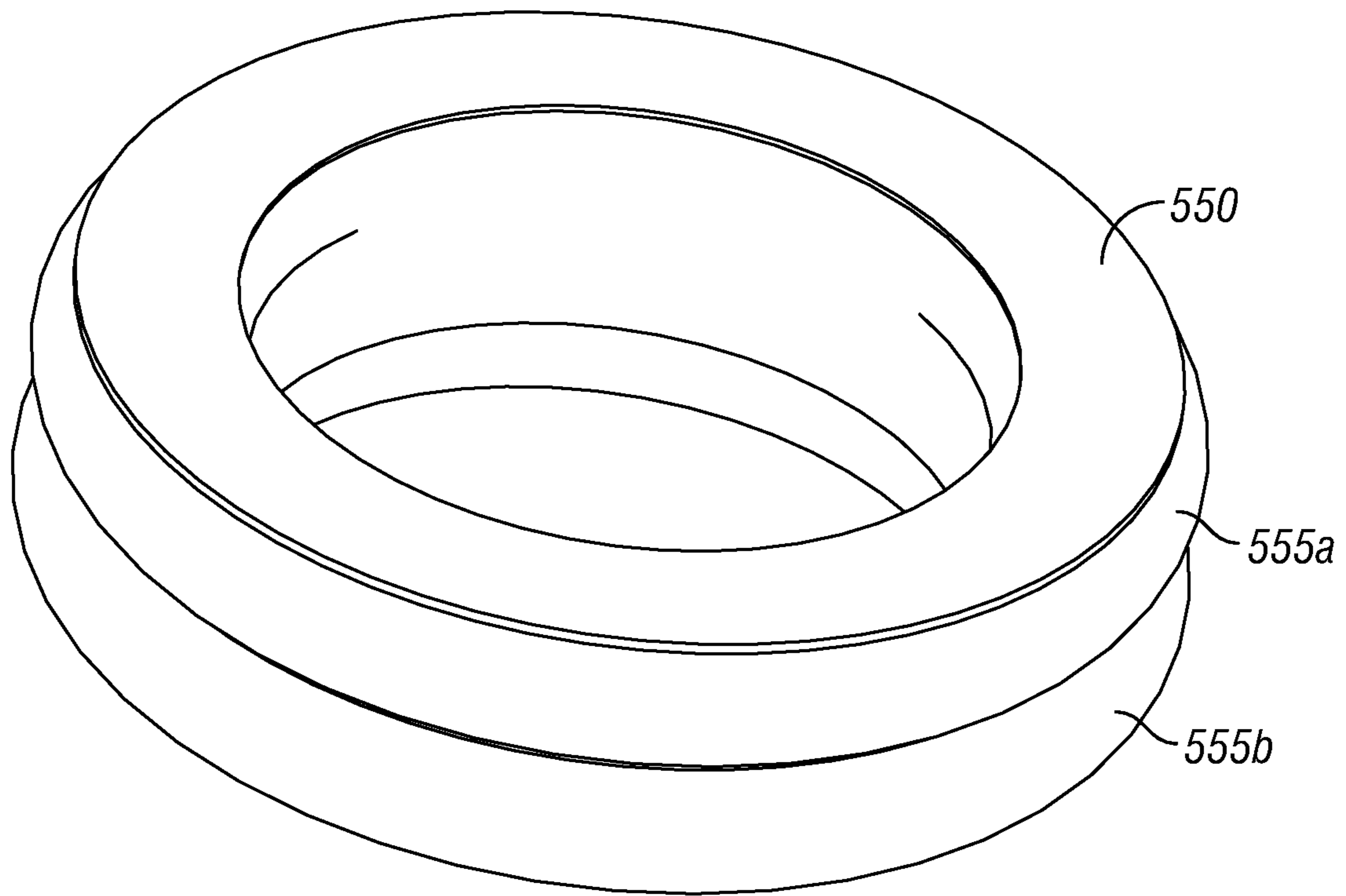
**FIG. 29B**



**FIG. 30A**



**FIG. 30B**



**FIG. 30C**



**FIG. 30D**

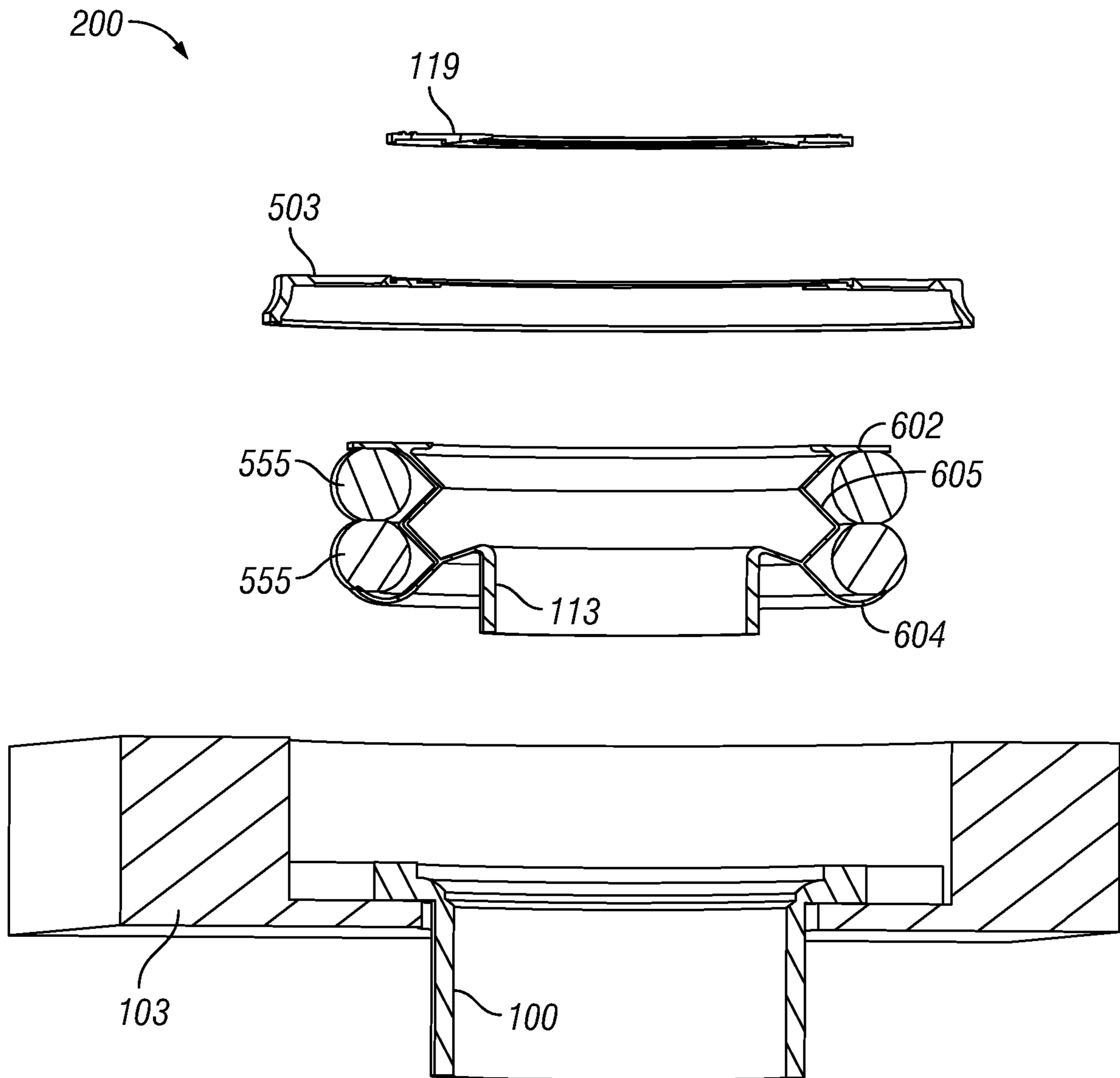
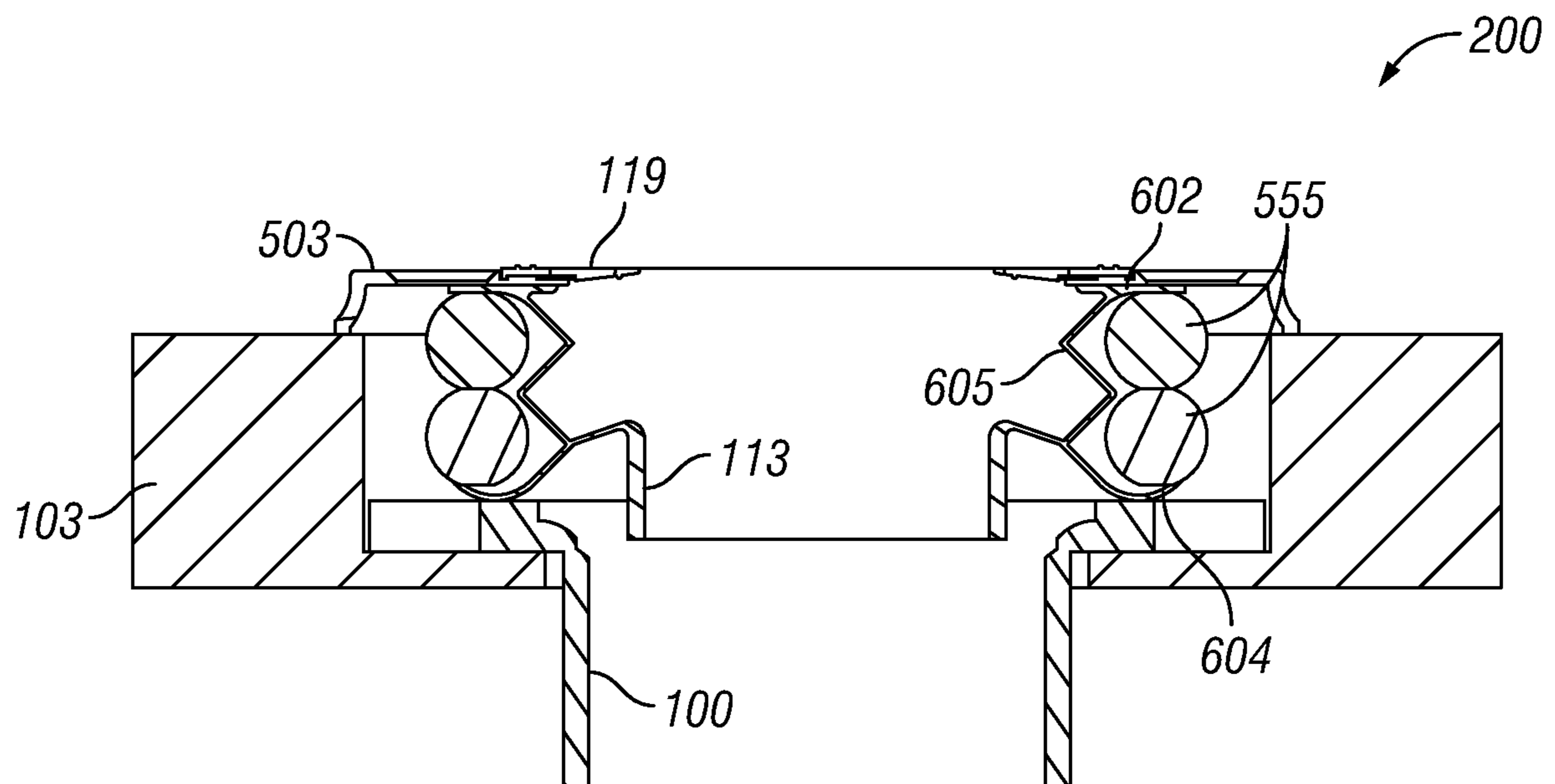
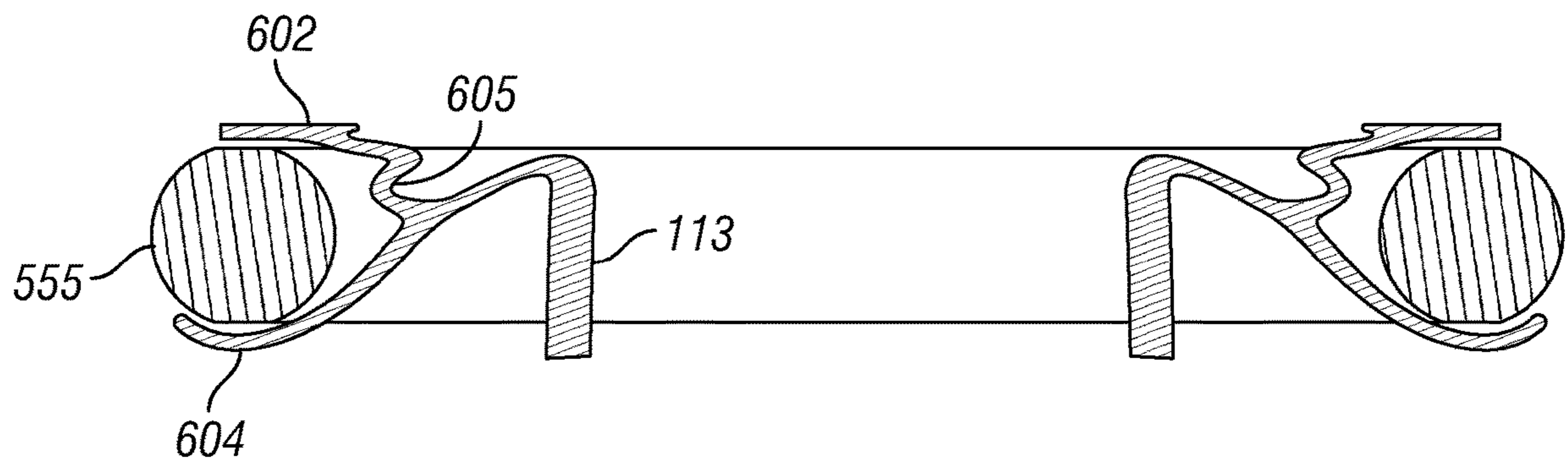


FIG. 31A

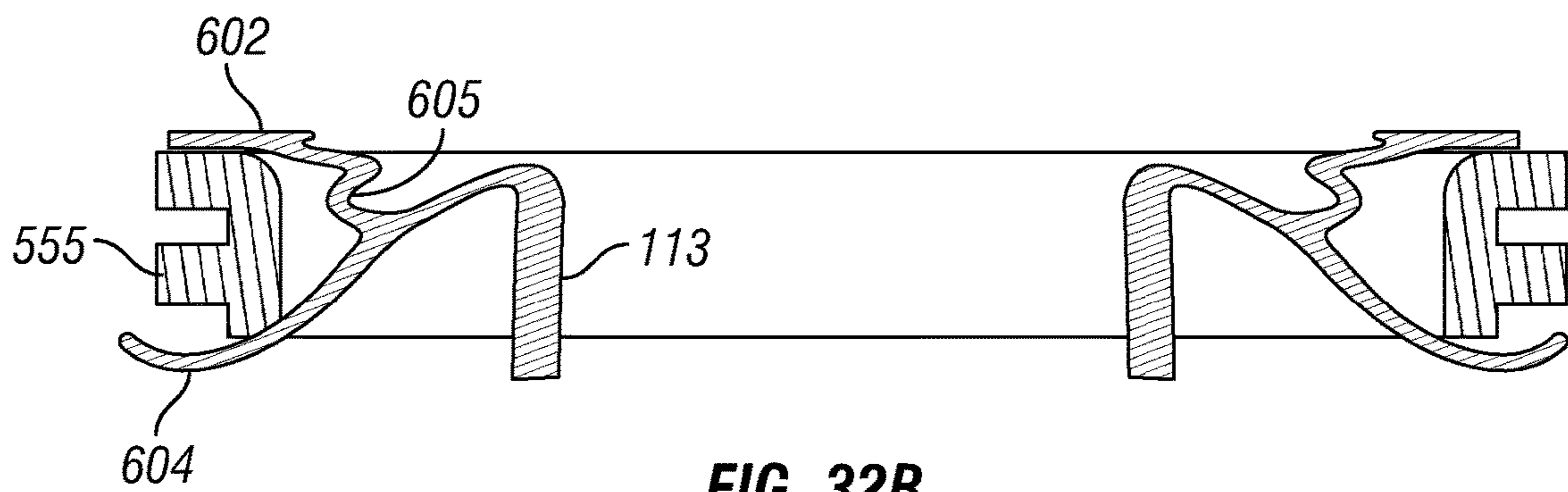




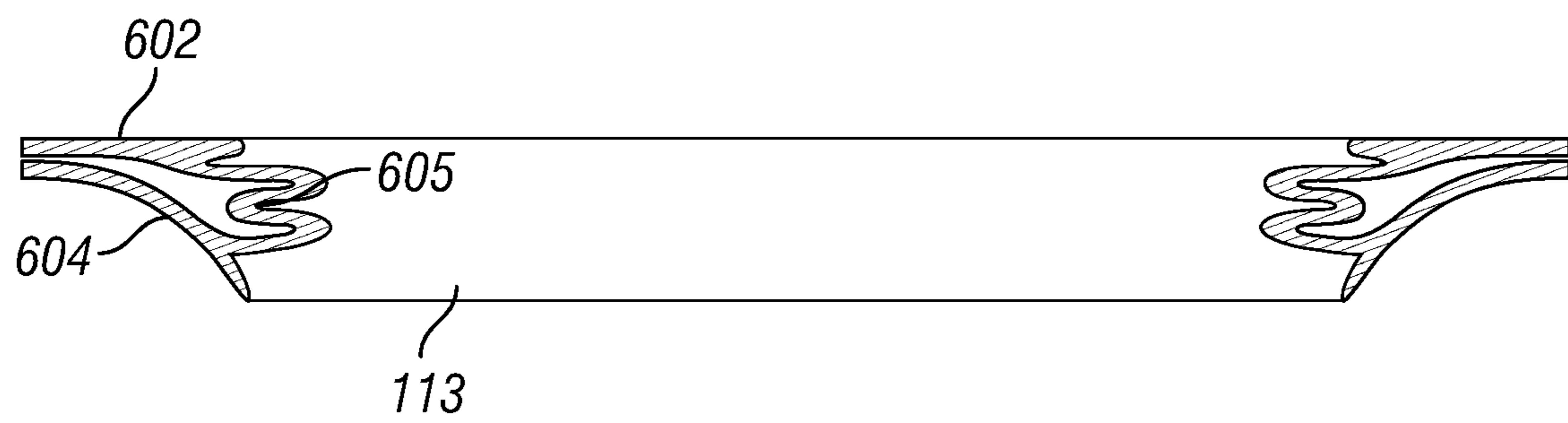
**FIG. 31B**



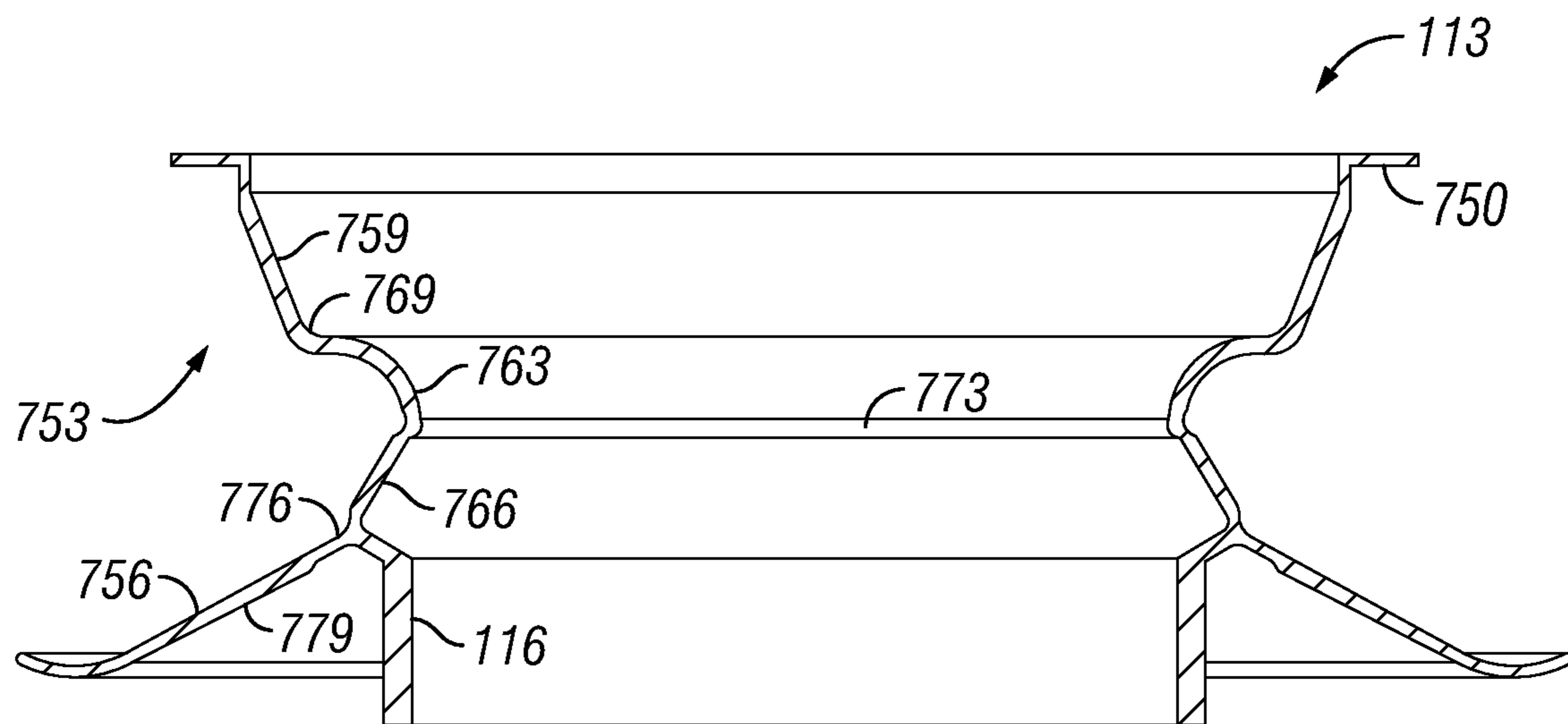
**FIG. 32A**



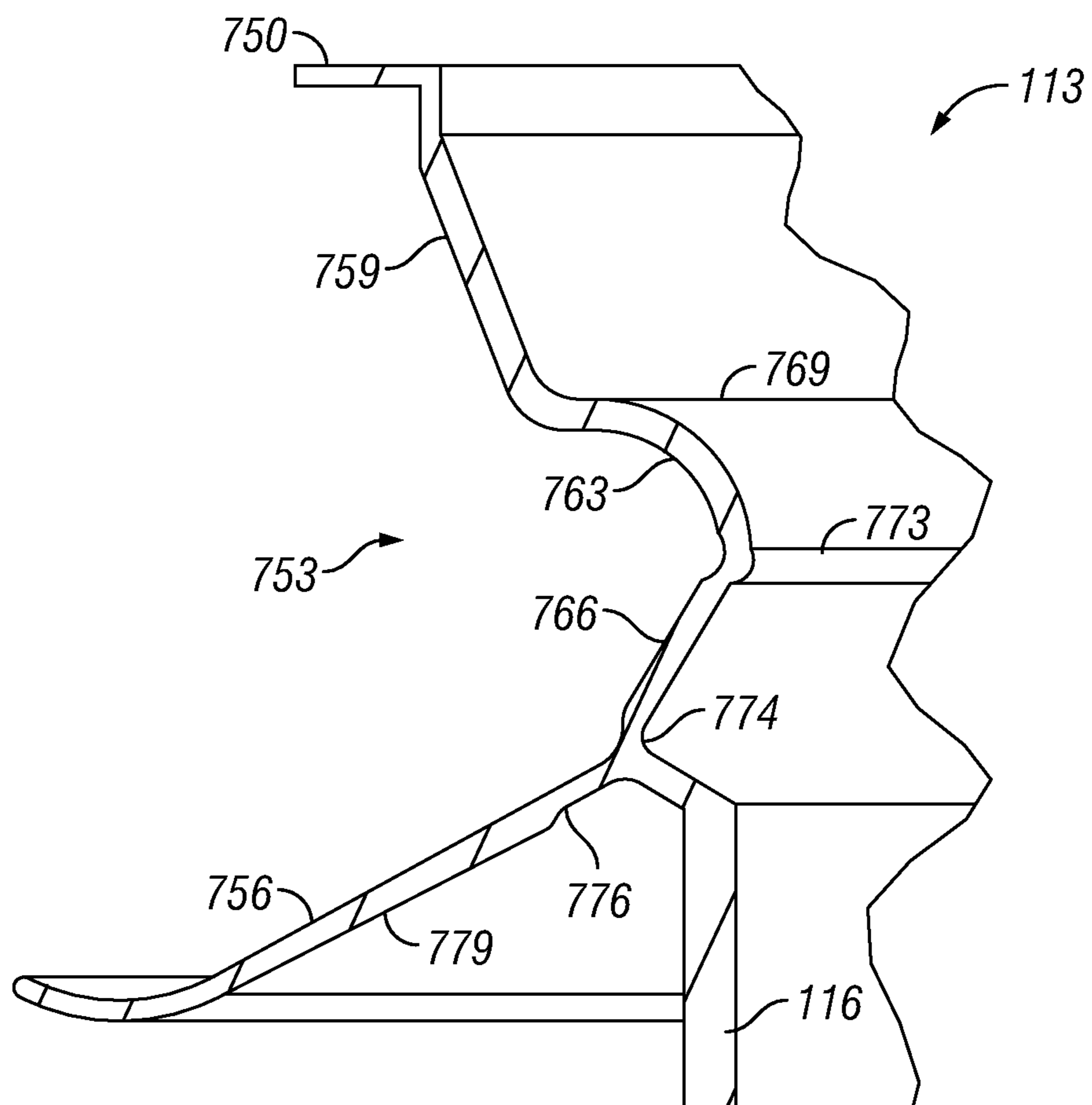
**FIG. 32B**



**FIG. 32C**

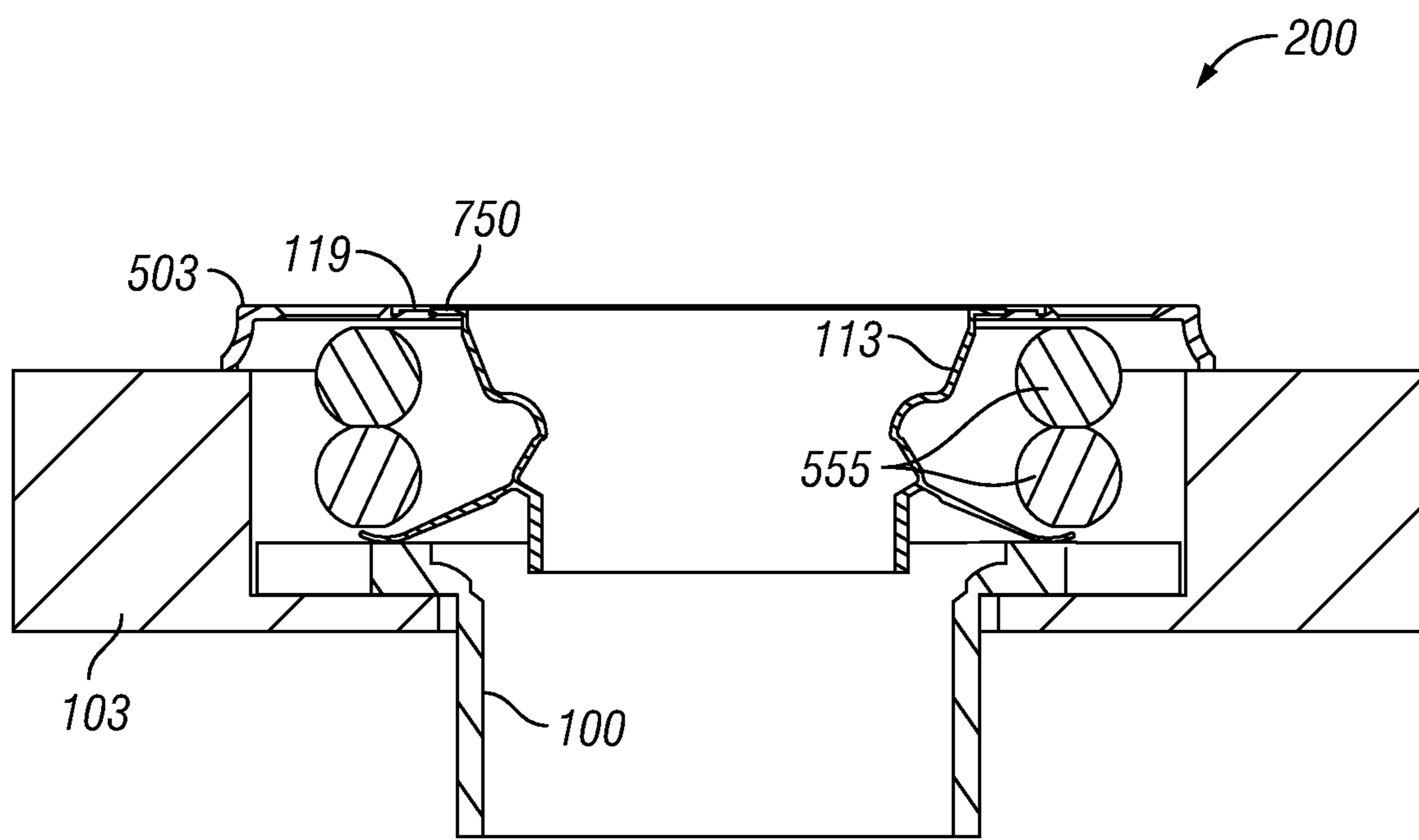


**FIG. 33A**

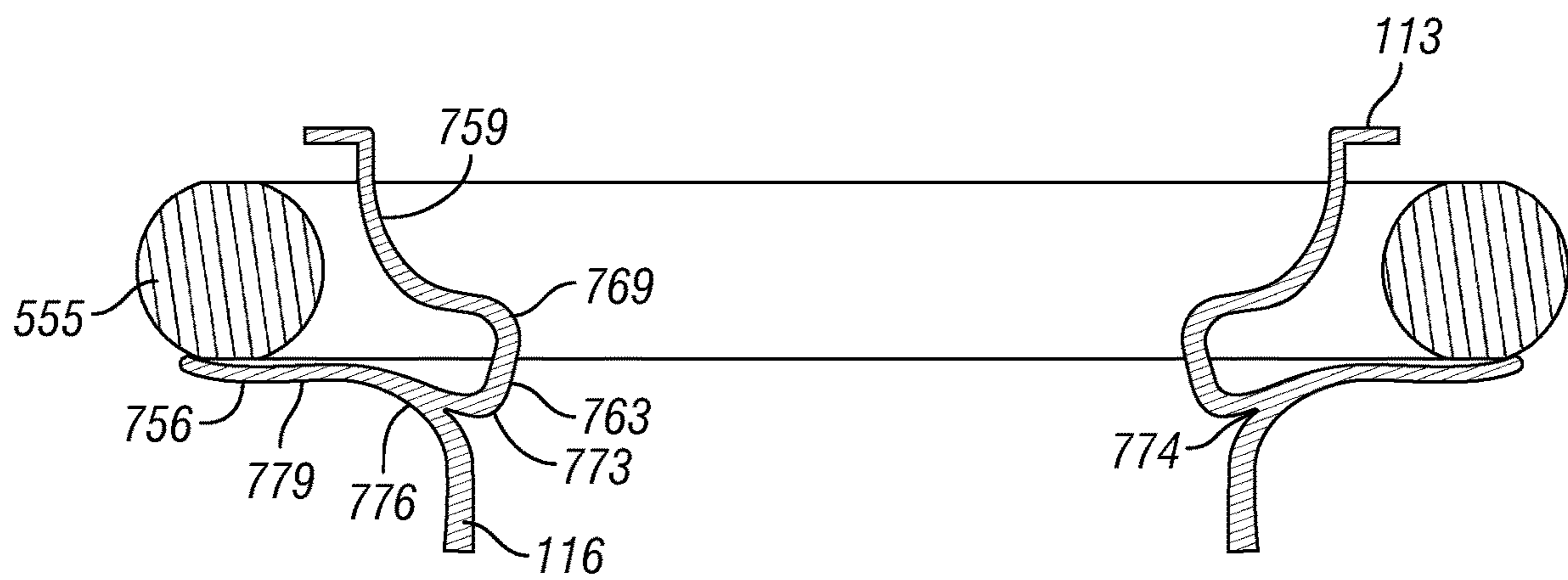


**FIG. 33B**

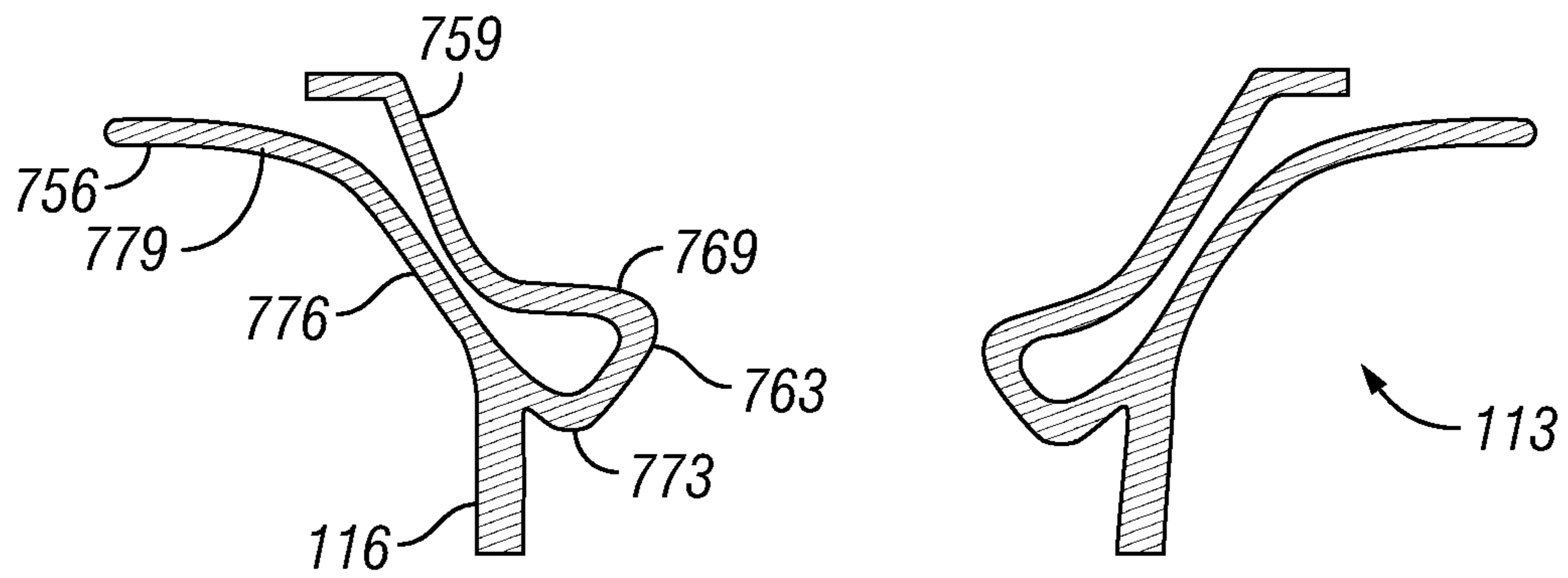




**FIG. 33C**



**FIG. 33D**



**FIG. 33E**



## TOILET SEALS

## CROSS-REFERENCE TO RELATED CASES

This application is a continuation of, and claims priority to, U.S. Utility Patent Application entitled "CLOSET COLLAR ADAPTATIONS" filed on Feb. 20, 2013 and assigned application Ser. No. 13/771,773, which claims priority to both U.S. Provisional Patent Application titled "CLOSET COLLAR ADAPTATION" filed on Feb. 20, 2012 and assigned application No. 61/600,794 and U.S. Provisional Patent Application titled "CLOSET COLLAR ADAPTATION" filed on Jul. 2, 2012 and assigned application No. 61/667,377. Each of these applications is incorporated by reference herein in its entirety.

## BACKGROUND

A closet collar may provide a connection between a toilet and a drain pipe. Closet collars can be installed improperly making it difficult to install a toilet without a leaky seal.

## BRIEF DESCRIPTION OF THE DRAWINGS

Many aspects of the present disclosure can be better understood with reference to the following drawings. The components in the drawings are not necessarily to scale, emphasis instead being placed upon clearly illustrating the principles of the disclosure. Moreover, in the drawings, like reference numerals designate corresponding parts throughout the several views.

FIGS. 1A-1C are drawings showing examples of a closet collar according to various embodiments of the present disclosure.

FIGS. 2A-2C are drawings showing examples of a closet collar adapter according to various embodiments of the present disclosure.

FIGS. 3-5 are drawings showing an example of a closet collar adaptation assembly according to various embodiments of the present disclosure.

FIG. 6 is a drawing showing another example of a closet collar adaptation assembly according to various embodiments of the present disclosure.

FIG. 7 is a drawing showing another example of a closet collar adaptation assembly according to various embodiments of the present disclosure.

FIG. 8 is a drawing showing an example of clips that may be used with a closet collar adaptation assembly according to various embodiments of the present disclosure.

FIGS. 9 and 10A-10B are drawings showing examples of flexible seal rings that may be used with a closet collar adaptation assembly according to various embodiments of the present disclosure.

FIGS. 11-14 are drawings showing an example of a sealing washer that may be used with a closet collar adaptation assembly according to various embodiments of the present disclosure.

FIG. 15 is a drawing showing another example of a closet collar adaptation assembly according to various embodiments of the present disclosure.

FIG. 16 is a drawing showing another example of a closet collar adaptation assembly according to various embodiments of the present disclosure.

FIGS. 17A-17B are drawings of another example of a closet collar adaptation assembly according to various embodiments of the present disclosure.

FIG. 18 is a drawing of an example of a toilet installed with a closet collar adaptation assembly according to various embodiments of the present disclosure.

FIGS. 19-20 are drawings of a closet collar adaptation assembly with a lid according to various embodiments of the present disclosure.

FIG. 21 is a drawing of another example of a closet collar adaptation assembly according to various embodiments of the present disclosure.

FIGS. 22A-22B are drawings of an example of an adapter plate for a closet collar adaptation assembly according to various embodiments of the present disclosure.

FIGS. 23A-23E are drawings of another embodiment of a sealing washer for a closet collar adaptation assembly according to various embodiments of the present disclosure.

FIGS. 24A-24B are drawings showing another example of a closet collar adaptation assembly according to various embodiments of the present disclosure.

FIGS. 25A-25C are drawings showing examples of an adapter plate for a closet collar adaptation assembly according to various embodiments of the present disclosure.

FIGS. 26A-26C are drawings showing examples of a closet collar adaptation assembly according to various embodiments of the present disclosure.

FIGS. 27A-27B are drawings showing an example of a bellow for a closet collar adaptation assembly according to various embodiments of the present disclosure.

FIG. 27C is a drawing showing another example of a closet collar adaptation assembly according to various embodiments of the present disclosure.

FIGS. 28A-28B, 29A-29B, and 30A-30D are drawings showing examples of flexible rings for a closet collar adaptation assembly according to various embodiments of the present disclosure.

FIGS. 31A-31B and 32A-32C are drawings showing another example of a closet collar adaptation assembly according to various embodiments of the present disclosure.

FIGS. 33A-33E are drawings showing another example of a closet collar adapter for a closet collar adaptation assembly according to various embodiments of the present disclosure.

## DETAILED DESCRIPTION

With reference to FIGS. 1A, 1B, and 1C, shown are examples of closet collars **100** upon which toilets may be installed. The closet collars **100** provide the drain point for a toilet where sewage leaves the toilet and is provided to a sewage system as can be appreciated. The closet collars **100** are shown relative to flooring **103**. In the embodiment of FIG. 1A, the closet collar **100** is recessed with respect to the flooring **103** so that the upper surface of the closet collar **100** is flush with the surface of the flooring **103**. Such may occur, for example, where the closet collar **100** is installed on subflooring and then finished flooring **103** is installed around the closet collar **100**. For example, ceramic tile or other types of a flooring **103** may be installed on subflooring and result in the upper surface of the closet collar **100** being flush with the surface of the flooring **103**. Referring to FIG. 1B, shown is a situation in which the closet collar **100** is recessed with respect to the flooring **103** such that the top surface of the closet collar **100** is below the top surface of the flooring **103**. Such may occur, for example, where the closet collar **100** is installed onto subflooring and then finished flooring having a relatively large thickness is installed around it. With reference to FIG. 1C, shown is a situation in which the closet collar **100** is installed on top of the flooring **103**. In the embodiment of FIG. 1C, the top surface of the closet collar



100 is above the top surface of the flooring 103. As contemplated herein, the closet collar 100 in any given installation might fall within any one of the configurations described with reference to FIG. 1A, 1B, or 1C.

With reference to FIGS. 2A, 2B, and 2C, shown is an example of a closet collar adapter 113 according to various embodiments. A closet collar adapter 113 includes a pipe extension 116 that is configured to extend down into a closet collar 100 (FIGS. 1A-1C). Also, a sealing washer 119 may be disposed on top of the closet collar adapter 113. According to various embodiments, the sealing washer 119 may be affixed to an upper surface of the closet collar adapter 113 by way of an appropriate adhesive, for example, thereby forming a sealed junction between the sealing washer 119 and the upper surface of the closet collar adapter 113. In alternative embodiments, the sealing washer 119 may be affixed to the upper surface of the closet collar adapter 113 by being overmolded or by using any other suitable process. In further alternative embodiments, the sealing washer 119 and the closet collar adapter 113 may be integrally molded as a single part. The sealing washer 119 may be made from rubber or other appropriate material that facilitates an appropriate seal with a horn extending from the underside of a toilet as will be described.

With reference to FIG. 3, shown is an example of a closet collar adaptation assembly 200 according to various embodiments of the present disclosure. According to various embodiments, the closet collar adaptation assembly 200 may include the closet collar adapter 113, a flexible seal ring 203, one or more anchor bolts 206, the sealing washer 119, and possibly other components. The closet collar adapter 113 may mount to and form a seal with the closet collar 100. Although the embodiment of FIG. 3 shows the components of the closet collar adaptation assembly 200 as being separate components, in alternative embodiments, one or more of the components of the adaptation assembly 200 may be integrally molded as a single component. In further alternative embodiments, one or more of the components of the closet collar adaptation assembly 200 may be bonded to form a single component using, for example, an overmolding process or any other suitable method.

Positioned above the closet collar adaptation assembly 200 is the bottom of a toilet 213 that includes the horn 216. The horn 216 of the toilet 213 mates with the closet collar adaptation assembly 200 to form a seal between the horn 216 and the closet collar 100. The seal between the horn 216 and the closet collar adaptation assembly 200 facilitates the passage of sewage matter from the toilet 213 through the closet collar 100 and down the drain pipe as can be appreciated.

The flexible seal ring 203 may be made of a material that facilitates the flexible seal ring 203 flexing and at least partially collapsing with pressure, thereby forming a seal between the underside of the closet collar adapter 113 and the sealing surface of the closet collar 100. In alternative embodiments, a wax ring may be used instead of or in addition to the flexible seal ring 203. Such a flexible seal ring 203 may be made of, for example, neoprene, foam rubber, polyvinylchloride (PVC) rubber, thermoplastic elastomer (TPE), thermoplastic rubber (TPR), styrene-butadiene rubber (SBR), ethylene propylene diene monomer (EPDM) rubber, or any other material that facilitates the flexible seal ring 203 at least partially collapsing and sealing against the respective surfaces. These materials may facilitate the flexible seal ring 203 being reusable, unlike a wax ring which typically is made for a single use. In this sense, when the toilet 213 and/or the closet collar adaptation assembly 200 is

removed, the flexible seal ring 203 may return at least partially to the shape in which it was prior to the toilet 213 and/or the closet collar adaptation assembly 200 causing the flexible seal ring 203 to at least partially collapse. Additionally, the flexible seal ring 203 may comprise an antimicrobial material. For example, the flexible seal ring 203 may comprise an antimicrobial coating.

Additionally, the material selected for the flexible seal ring 203 may be chosen so that it may withstand the corrosive effects of the sewage gases and matter that flows from the toilet 213 into the drain through the closet collar 100 as can be appreciated. The closet collar adaptation assembly 200 is shown in FIG. 3 using an exploded view in which components have not yet been completely assembled.

Referring to FIG. 4, shown is the closet collar adaptation assembly 200 in which the closet collar adapter 113 has been pushed down onto the flexible seal ring 203, thereby compressing the flexible seal ring 203 as shown. The sealing washer 119 is disposed at the top of the closet collar adapter 113 and includes a hole through which the horn 216 of the toilet 213 protrudes. The sealing washer 119 may thereby form a seal with the sides of the horn 216 to prevent sewage gases or other matter from escaping during the toilet flush cycle or at other times. The anchor bolts 206 may be restricted to the closet collar 100 in holes or slots that are typically found within closet collars 100 as can be appreciated.

With reference to FIG. 5, shown is an example of the closet collar adaptation assembly 200 in which the toilet 213 has been placed over the closet collar adaptation assembly 200 and the horn 216 has been pressed through the center opening of the sealing washer 119. As shown, the sealing washer 119 may be stretched down around the sides of the horn 216, thereby forming a seal between the side of the horn 216 and the sealing washer 119. In addition, wax may be provided at strategic locations inside the closet collar adapter 113 so that the sides of the horn 216 may come into contact with the wax to form a seal in addition to, or as an alternative to, the use of the sealing washer 119. For example, such wax may be placed in the corner 223 or in other locations formed in the closet collar adapter 113. As a result, the wax may contact a portion of the horn 216 to further form a seal between the horn 216 and closet collar adapter 113. In alternative embodiments, the side walls of the closet collar adapter 113 may be shaped to provide for holding areas or reservoirs in which wax or other sealants may be retained. When the horn 216 is inserted into closet collar adapter 113, the wax or other sealants in the holding areas or reservoirs may come into contact with the horn 216. The holding areas or reservoirs may provide for greater precision in terms of sealing to prevent sewage leaks and may also facilitate assembly and/or installation of the closet collar adaptation assembly 200.

With reference to FIG. 6, shown is a closet collar adaptation assembly 300 according to another embodiment of the present disclosure. The closet collar adaptation assembly 300 is similar to the closet collar adaptation assembly 200 described above, with the exception that the closet collar adaptation assembly 300 shown in FIG. 6 includes multiple flexible seal rings 203a and 203b that are sandwiched together as shown. In the embodiment shown in FIG. 6, the closet collar adaptation assembly 300 includes two flexible seal rings 203a and 203b. However, fewer or greater quantities of flexible seal rings 203a and 203b may be used in alternative embodiments. Having multiple flexible seal rings 203a and 203b may provide a proper seal between the closet collar adapter 113 and the closet collar 100 when the closet



## 5

collar **100** is recessed relatively far down in the flooring **103** (FIG. 1) as can be appreciated.

With reference to FIG. 7, shown is another example of a closet collar adaptation assembly **330** according to various embodiments. The closet collar adaptation assembly **330** in the embodiment of FIG. 7 includes an adapter plate **333** that includes a hole through which the horn **216** (FIG. 3) of a toilet may protrude. The sealing washer **119** may be affixed to the top of the adapter plate **333** and may form a sealed joint therebetween. The flexible seal ring **203** is disposed between the adapter plate **333** and the closet collar **100** as shown. The horn **216** of a toilet may be positioned to extend through the sealing washer **119** and the inner hole of the adapter plate **333**, thereby forming a seal between the sides of the horn **216** of the toilet, as described above, via the sealing washer **119**. Thus, the closet collar adaptation assembly **330** provides for the installation of a toilet **213** without the use of the closet collar adapter **113** described above.

Although the embodiment of FIG. 7 shows the components of the closet collar adaptation assembly **330** as being separate components, in alternative embodiments, one or more of the components of the adaptation assembly **330** may be integrally molded as a single component. In further alternative embodiments, one or more of the components of the closet collar adaptation assembly **330** may be bonded to form a single component using, for example, an overmolding process or any other suitable method. For example, the sealing washer **119** may be overmolded to the adapter plate **333** in various embodiments.

Referring next to FIG. 8, shown is a view of an example of clips **353** that may be used with various closet collar adaptation assemblies **200** according to various embodiments. In FIG. 8, the clips **353** are shown being used with the closet collar adaptation assembly **200**. In alternative embodiments, the clips **353** may be used with the closet collar adaptation assembly **300** (FIG. 6), the closet collar adaptation assembly **330** (FIG. 7), or with other embodiments. The clips **353** may be slid onto the anchor bolts **206** so that they make contact with the sealing washer **119** (FIG. 2) that is disposed on top of the closet collar adapter **113**. The clips **353** may be pushed down such that the flexible seal ring (not shown) is compressed by the clips **353** to hold the closet collar adaptation assembly **200** and to hold the anchor bolts **206** in place, thereby facilitating the toilet **213** (FIG. 3) being positioned over the closet collar adaptation assembly **200**.

Referring to FIG. 9, shown are two examples of the flexible seal ring **203**, denoted here as flexible seal ring **203c** and flexible seal ring **203d**. The flexible seal ring **203c** may comprise foam rubber, PVC rubber, neoprene, or other types of sealing materials. Such materials may be antimicrobial according to various embodiments. Additionally, the flexible seal ring **203** according to various embodiments may comprise a coating, such as an antimicrobial coating. The flexible seal ring **203d** may be manufactured from extruded rubber or other types of suitable materials as can be appreciated.

Referring next to FIGS. 10A and 10B, shown are cross-sectional views of the flexible seal rings **203c** and **203d**. As shown, the flexible seal ring **203d** has several walls that may facilitate the flexible seal ring **203d** at least partially collapsing when compressed. The flexible seal ring **203c** comprises a material that may facilitate the flexible seal ring **203c** at least partially collapsing to form the appropriate seals as can be appreciated.

With reference to FIGS. 11, 12, 13, and 14, shown is the sealing washer **119** positioned on the upper flat surface of the

## 6

closet collar adapter **113** according to various embodiments. In the embodiments of FIGS. 11, 12, 13, and 14, the sealing washer **119** comprises a center hole **403** with a radius that is less than the radius of the opening **406** for the closet collar adapter **113**. According to various embodiments, the closet collar adapter **113** may comprise one or more holes **409** through which bolts, screws, or any other suitable type of fasteners may insert to hold at least portions of the system down as can be appreciated.

Referring next to FIG. 15, shown is another example of a closet collar adaptation assembly **500** according to various embodiments. The closet collar adaptation assembly **500** in the embodiment of FIG. 15 includes the sealing washer **119** and the closet collar adapter **113**. In addition, disposed over the closet collar adapter **113** is an adapter plate **503**. The adapter plate **503** may be constructed of steel, aluminum, or other metal as can be appreciated. In alternative embodiments, the adapter plate **503** may be constructed of plastic, for example, or any other type of suitable material. The adapter plate **503** according to various embodiments may also comprise an integrated antimicrobial agent. Additionally or alternatively, various embodiments of the adapter plate **503** may include an antimicrobial coating, such as an antimicrobial paint, an antimicrobial metal powder coating, or any other type of finish.

Although the embodiment of FIG. 15 shows the components of the closet collar adaptation assembly **500** as being separate components, in alternative embodiments, one or more of the components of the adaptation assembly **500** may be integrally molded as a single component. In further alternative embodiments, one or more of the components of the closet collar adaptation assembly **500** may be bonded to form a single component using, for example, an overmolding process or any other suitable method. For example, the sealing washer **119**, the closet collar adapter **113**, and/or other components may be overmolded to the adapter plate **503** in various embodiments.

The adapter plate **503** may include one or more legs **506** that can be used to fasten the adapter plate **503** to the flooring **103** (FIG. 1A), thereby holding the closet collar adaptation assembly **500** in proper position with respect to the closet collar **100** (FIG. 1A). It may be that the feet of the legs **506** come into contact with the flooring **103**, or they might be suspended above the flooring **103** such that a screw or bolt rigidly adheres the legs **506** to the flooring **103**.

Protruding from the adapter plate **503** are bolts **509** that may be, for example, affixed directly to the adapter plate **503** according to various embodiments. The bolts **509** may insert into corresponding holes in the toilet **213** (FIG. 3) and be used to fasten the toilet **213** to the closet collar adaptation assembly **500**. The flexible seal ring **203** may be disposed under the closet collar adapter **113** as described above. The adapter plate **503** may provide greater stability in that it may be attached to the flooring **103** around the closet collar **100** for cases, for example, where the closet collar **100** may be broken or otherwise compromised. In addition, screws may be used to affix the adapter plate **503** to the floor structure through the holes **513** as shown. Such screws may protrude through the flexible seal ring **203** according to various embodiments.

With reference to FIG. 16, shown is an example of the closet collar adaptation assembly **500** after it has been installed over a closet collar **100** (not visible) such that the legs **506** come into contact with flooring **103**. By bolting the adapter plate **503** to the flooring **103**, greater stability of the connection between the toilet and the closet collar **100** may be provided.



With reference to FIGS. 17A and 17B, shown are additional drawings of the closet collar adaptation assembly 500 according to various embodiments of the present disclosure. In particular, FIG. 17A shows a partially-exploded side view, and FIG. 17B shows a partially-exploded cross-section view of the closet collar adaptation assembly 500 according to various embodiments. According to various embodiments, the sealing washer 119 may include thickened portions 533 along the outside diameter of the sealing washer 119 that are configured to contact the adapter plate 503. According to various embodiments, the thickened portions 533 may be adhered to the adapter plate 503. Also, the sealing washer 119 is configured to contact the closet collar adapter 113. According to various embodiments, the sealing washer 119 may be sealed or affixed to the closet collar adapter 113 to form a seal between the closet collar adapter 113 and the sealing washer 119. Thus, the sealing washer 119 may be affixed to both the closet collar adapter 113 and the adapter plate 503 to promote a seal to prevent sewage gases from escaping as can be appreciated. In another embodiment, the sealing washer 119 may comprise a constant thickness and simply may be bent down around the upper surface of the closet collar adapter 113 to be affixed to the adapter plate 503.

With reference to FIG. 18, shown is the closet collar adaptation assembly 500 for which a toilet 213 has been installed over a closet collar 100. As shown, the sealing washer 119 makes contact with the horn 216 of the toilet 213. Additionally, the sealing washer 119 may be adhered to both the closet collar adapter 113 and the adapter plate 503 so as to prevent sewage gases from escaping through the junction of the closet collar adapter 113 and the adapter plate 503.

Referring to FIGS. 19 and 20, shown is the closet collar adaptation assembly 500 with a lid 553 positioned over the opening provided by the closet collar adaptation assembly 500. The lid 553 may include protrusions 556 into which the anchor bolts 206 may insert to thereby facilitate the anchor bolts 206 coupling the lid 553 to the closet collar adaptation assembly 500. In some embodiments, the protrusions 556 may include internal teeth, ribs, and/or other features that may facilitate the anchor bolts 206 being restricted in the protrusions 556. The lid 553 being coupled to the closet collar adaptation assembly 500 may provide a seal over the closet collar 100.

With reference to FIG. 21, shown is an example of the closet collar adaptation assembly 600 according to another embodiment of the present disclosure. As shown, the closet collar adaptation assembly 600 includes the closet collar adapter 113 that is positioned over the closet collar 100 with the flexible seal ring 203 disposed therebetween. As shown, the flexible seal ring 203 may provide a direct seal between the closet collar adapter 113 and the closet collar 100. The sealing washer 119 is disposed on the upper surface of the closet collar adapter 113. In addition, an adapter plate 603 is positioned above the sealing washer 119. The adapter plate 603 may be affixed to the sealing washer 119 by, for example, an appropriate adhesive, fasteners, or any other suitable mechanism. Alternatively, the adapter plate 603 may simply be placed over the assembly as shown. The adapter plate 603 may include holes 513 (FIG. 15) and legs 506 (FIG. 15) that are not shown in the embodiment of FIG. 21. Bolts 606 extend from the upper surface of the adapter plate 603 in the present embodiment.

According to various embodiments, the closet collar adaptation assembly 600 may be advantageous in that there are fewer joints to seal to prevent sewage gases and other

matter from escaping the joint between the toilet 213 (FIG. 3) and the closet collar 100. Specifically, the flexible seal ring 203 provides for sealing between the closet collar adapter 113 and the closet collar 100. Also, the sealing washer 119 is directly positioned on the upper surface of the closet collar adapter 113. This may provide greater surface area for a greater seal. Further, the adapter plate 603 may provide greater stability for all of the seals and may hold the entire closet collar adaptation assembly 600 in place over the closet collar 100 as can be appreciated.

In addition, a plug 609 may be provided that may be pushed into the hole presented by the sealing washer 119 to plug the hole over the closet collar 100. The plug 609 may prevent the escape of sewage gases when a toilet has not been installed. To this end, the plug 609 may be employed with any one of the embodiments of the various closet collar adaptation assemblies described herein.

Although the embodiment of FIG. 21 shows the components of the closet collar adaptation assembly 600 as being separate components, in alternative embodiments, one or more of the components of the adaptation assembly 600 may be integrally molded as a single component. In further alternative embodiments, one or more of the components of the closet collar adaptation assembly 600 may be bonded to form a single component using, for example, an overmolding process or any other suitable method. For example, the sealing washer 119, the closet collar adapter 113, and/or other components may be overmolded to the adapter plate 603 in various embodiments.

With reference to FIGS. 22A-22B, shown is the adapter plate 503 according to various embodiments. In the embodiment shown, the bolts 706a-706b are separate components from the adapter plate 503. The adapter plate 503 in FIGS. 22A-22B includes one or more holes 703a-703d to receive the bolts 706a-706b. The bolts 706a-706b may be passed into the corresponding holes 703a-703d so that the bolt heads 709a-709b may be flush with the adapter plate 503. A press fit, threads, or any other suitable type of mechanism may retain the bolts 706a-706b in the holes 703a-703d.

Turning now to FIGS. 23A-23E, shown is an interaction of the adapter plate 503 and the sealing washer 119 according to various embodiments. In the embodiment shown, the adapter plate 503 now includes one or more receptacles 713, and the sealing washer 119 includes corresponding protrusions 716. When the sealing washer 119 is seated on the adapter plate 503 during assembly, for example, the protrusions 716 of the sealing washer 119 may insert into the receptacles 713 of the adapter plate 503. Having the protrusions 716 fit in the receptacles 713 may facilitate a proper concentric alignment of the sealing washer 119 with respect to the adapter plate 503. As best shown in FIG. 23E, the sealing washer 119 may also include a lip 719 that provides a space to accommodate the closet collar adapter 113, as will be shown later.

With reference to FIG. 24A, shown is the closet collar adaptation assembly 200 according to various embodiments. The closet collar adaptation assembly 200 may include the adapter plate 503, the closet collar adapter 113, the sealing washer 119, and potentially other components. The adapter plate 503 may be mounted to the surface of the flooring 103, and the closet collar adapter 113 may be seated on the adapter plate 503 as shown. Additionally, the sealing washer 119 may be seated on the closet collar adapter 113 and the adapter plate 503. A portion of the closet collar adapter 113 may also fit between the adapter plate 503 and the lip 719 of the sealing washer 119. By the protrusions 716 of the sealing washer 119 being inserted into the receptacles 713 of the



adapter plate **503**, proper concentric alignments of the adapter plate **503**, the sealing washer **119**, and the closet collar adapter **113** may be obtained. As shown in FIG. **24A**, the bolts **706a-706b** may pass through and be retained in the corresponding holes **703a-703b** of the adapter plate **503** so that the bolt heads **709a-709b** are flush with the adapter plate **503**.

Turning to FIG. **24B**, shown is the closet collar adaptation assembly **200** according to various embodiments. As shown in FIG. **24B**, the closet collar adapter **113** may be flexible to accommodate various flooring **103**, closet collar **100**, and/or drain pipe geometries. To this end, the closet collar adapter **113** may comprise a neoprene, foam rubber, polyvinylchloride (PVC) rubber, thermoplastic elastomer (TPE), thermoplastic rubber (TPR), styrene-butadiene rubber (SBR), ethylene propylene diene monomer (EPDM) rubber, flexible PVC, or another type of suitable material. One or more of the components of the closet collar adaptation assembly **200**, such as the closet collar adapter **113** and/or the sealing washer **119** may comprise an antimicrobial material, such as an integrated antimicrobial agent and/or an antimicrobial coating.

Further, one or more of the components of the closet collar adaptation assembly **200**, such as the closet collar adapter **113** and/or the sealing washer **119**, may be constructed using an overmolding process. The use of thermoplastic rubber flexible PVC, or thermoplastic elastomer may facilitate construction of the closet collar adapter **113** using injection molding processes. Additionally, one or more of the components of the closet collar adaptation assembly **200**, such as the closet collar adapter **113** and/or the sealing washer **119** may be integrally molded as a single part according to various embodiments.

Turning to FIG. **25A**, shown is an alternative embodiment of the adapter plate **503** according to various embodiments. As shown, the clips **353** may be formed as part of the adapter plate **503**. The clips **353** may also accept and retain the anchor bolts **206**. The clips **353** in the present embodiment comprise mouths that may grip anchor bolts **206**.

Referring now to FIG. **25B**, shown is another embodiment of the adapter plate **503**. In this embodiment, the adapter plate **503** includes elongated slots **803** that receive the anchor bolts **206** (FIG. **3**). Because the slots **803** are elongated, the closet collar adapter **113** may accept anchor bolts **206** that are at various radial distances with respect to the center of the adapter plate **503**.

Turning to FIG. **25C**, shown is another embodiment of the adapter plate **503**. In the embodiment shown, elongated clips **806** are now formed as part of the adapter plate **503**. The elongated clips **806** in the present example comprise teeth that may grip anchor bolts **206** (FIG. **3**). The elongated clips **806** may accept and retain the anchor bolts **206** that are at various radial distances with respect to the center of the adapter plate **503**.

With reference to FIGS. **26A-26C**, shown is the closet collar adaptation assembly **200** according to various embodiments. As shown, the adapter plate **503** may be seated on the flooring **103**. Also, the closet collar adapter **113** may be seated between the sealing washer **119** and the adapter plate **503**. The sealing washer **119** and/or the closet collar adapter **113** may be glued to the adapter plate **503**, for example, during assembly of the closet collar adaptation assembly **200**. Further, the sealing washer **119** and the closet collar adapter **113** may be glued together. In some embodiments, gluing the closet collar adapter **113** may be omitted,

because the closet collar adapter **113** may be seated and retained between the sealing washer **119** and the adapter plate **503**.

As best shown in FIG. **26C**, the bottom opening of the pipe extension **116** for the closet collar adapter **113** is at a level that is lower than the top opening of the closet collar **100**. Thus, wastes passing through the pipe extension **116** may pass from the closet collar adapter **113** through the closet collar **100**.

Turning now to FIGS. **27A-27B**, shown is a bellow **550** according to various embodiments. The bellow **550** may include a first lip **553**, a second lip **556**, a ridge **559**, and a collapsible portion **563**. The bellow **550** may comprise a flexible material, such as flexible PVC, thermoplastic rubber, a thermoplastic elastomer, or any other type of material. In various embodiments, the bellow **550**, sealing washer **119**, closet collar adapter **113**, and/or other components may be constructed using overmolding techniques. For example, these components may be overmolded to the adapter plate **503** using through-holes in the adapter plate **503** to facilitate a bond between the components.

With reference now to FIG. **27C**, shown is the closet collar adaptation assembly **200** according to various embodiments. The closet collar adaptation assembly **200** includes the adapter plate **503** seated on the flooring **103**. The sealing washer **119** may be seated on the adapter plate **503**, and the closet collar adapter **113** may be seated between the adapter plate **503** and the sealing washer **119**. Additionally, the bellow **550** may be disposed between the top of the closet collar **100** and the bottom of the adapter plate **503**. In this sense, the first lip **553** of the bellow **550** may be in contact with the adapter plate **503**, and the second lip **556** and the ridge **559** may be in contact with the closet collar **100**. In some embodiments, an adhesive may be disposed on the first lip **553** and/or the second lip **556** to facilitate installation and/or a seal. Also, in various embodiments, the first lip **553** of the bellow may be overmolded to the adapter plate **503**. Thus, the bellow **550** may act as a seal and thereby prevent liquids and/or gases from escaping from the closet collar adaptation assembly **200**.

One or more of the flexible rings **555** may be located between the bellow **550** and the flooring **103**. The flexible rings **555** may comprise rubber, foam, or any other type of material. Additionally, the flexible rings **555** may be compressible and thereby facilitate the closet collar adaptation assembly **200** being compatible with closet collars **100** that are at various heights with respect to the flooring **103**.

Turning now to FIG. **28A**, shown is an alternative embodiment of the flexible ring **555** according to various embodiments. The flexible ring **555** may include one or more grooves **570**, for example, along an exterior circumference of the flexible ring **555**. The flexible ring **555** may be manufactured using an extrusion process or other type of process, and ends of the extruded material may be glued together in order to form the ring shape.

FIG. **28B** shows an interaction of the flexible ring **555** of FIG. **28A** with the bellow **550** according to various embodiments. The flexible ring **555** may be disposed between the first lip **553** and the second lip **556** of the bellow **550**.

With reference to FIG. **29A**, shown is an interaction of the bellow **550** with the flexible ring **555** according to various embodiments. In the embodiment shown, the flexible ring **555** has a circular cross-section. As shown, the collapsible portion **563** of the bellow **550** may at least partially collapse. Upon the collapsible portion **563** at least partially collapsing



## 11

due to a force exerted, for example by the adapter plate **503**, the first lip **553** and second lip **556** may be in contact with the flexible ring **555**.

Turning now to FIG. **29B**, shown is an interaction of the bellow **550** with the flexible ring **555** according to further 5 embodiments. In this embodiment, the flexible ring **555**, referred to herein as the flexible ring **555a**, may be a portion that has been cut and removed from the flexible ring **555** shown in FIG. **28A**.

With reference to FIG. **30A** shown is an alternative 10 embodiment of the flexible ring **555a**. FIG. **30A** shows multiple flexible rings **555**, referred to herein as the flexible ring **555a** and the flexible ring **555b**. The flexible rings **555a-555b** may be hollow according to various embodiments.

FIG. **30B** shows an interaction of the flexible rings **555a-555b** of FIG. **30A** with the bellow **550** according to various embodiments. One or more flexible rings **555a-555b** may be stacked to facilitate a proper seal between the closet collar adapter **113** (FIG. **24A**) and the closet collar **100** (FIG. 20 **24A**) when the closet collar **100** is recessed in the flooring **103** (FIG. **24A**).

With reference to FIGS. **30C-30D**, shown is an alternative 25 embodiment of the first flexible ring **555a** and the second flexible ring **555b** and their interactions with the bellow **550** according to various embodiments. As shown, the first flexible ring **555a** and the second flexible ring **555b** may be connected at a joint **575** and thus formed as a single component. A user, for example, may cut along the joint **575** to separate the first flexible ring **555a** from the second 30 flexible ring **555b**.

Referring to FIGS. **31A-31B**, shown is an alternative 35 embodiment of the closet collar adaptation assembly **200** according to various embodiments. In the embodiment shown, the closet collar adaptation assembly **200** includes the sealing washer **119**, the adapter plate **503**, one or more flexible rings **555**, and the closet collar adapter **113**. The closet collar adapter **113** in the embodiment shown may perform a similar function as the bellow **550** (FIG. **30A**) discussed above. In particular, the closet collar adapter **113** 40 in the present embodiment may act as a seal and thereby prevent liquids and/or gases from escaping from the closet collar adaptation assembly **200**. To this end, the closet collar adapter **113** may include a first lip **602**, a second lip **604**, and a collapsible portion **605**. As best shown in FIG. **31B**, the first lip **602** may abut the adapter plate **503** and one of the flexible rings **555**. Similarly, the second lip **604** may abut the closet collar **100** and one of the flexible rings **555**. Thus, the closet collar adapter **113** may provide a seal and thereby 45 prevent liquids and/or gases from escaping from the closet collar adaptation assembly **200**.

In some embodiments, the first lip **602** may be positioned between the adapter plate **503** and the sealing washer **119**. Also, some or all of the flexible components may be molded as a single component. For instance, all of the flexible 50 components may be overmolded onto the adapter plate **503**.

Referring to FIG. **32A**, shown is an example of a portion of the closet collar adaptation assembly **200** of FIGS. **31A-31B** for which a single flexible ring **555** is being used. As shown, the first lip **602** and the second lip **604** of the closet collar adapter **113** are in contact with the flexible ring **555**, and the collapsible portion **605** of the closet collar adapter **113** is now at least partially collapsed.

With reference to FIG. **32B**, shown is an example of a 65 portion of the closet collar adaptation assembly **200** of FIGS. **31A-31B** according to various embodiments. In the present example, a portion of the flexible ring **555** of FIG. **28A** is

## 12

being used. As shown, the first lip **602** and the second lip **604** of the closet collar adapter **113** are in contact with the flexible ring **555**, and the collapsible portion **605** of the closet collar adapter **113** is now at least partially collapsed.

Referring to FIG. **32C**, shown is an example of a portion 5 of the closet collar adaptation assembly **200** of FIGS. **31A-31B** for the case in which a flexible ring **555** (FIG. **32B**) is not used. As shown, the collapsible portion **605** of the closet collar adapter **113** has partially collapsed to an extent that is even greater than as shown in FIGS. **32A-32B**.

With reference now to FIGS. **33A-33B**, shown is another 10 example of a closet collar adapter **113** according to various embodiments. The closet collar adapter **113** shown may include a lip **750**, a collapsible portion **753**, a base **756**, and the pipe extension **116**. The collapsible portion **753** may further include a first portion **759**, a second portion **763**, and a third portion **766** of the closet collar adapter **113**. A first edge **769** may connect the first portion **759** and the second portion **763** of the collapsible portion **753**. Further, a second 15 edge **773** may connect the second portion **763** and the third portion **766** of the collapsible portion **753** of the closet collar adapter **113**. Additionally, a third edge **774** may connect the third portion **766** of the collapsible portion **753** to the base **756**.

The first portion **759** of the collapsible portion **753** of the closet collar adapter **113** may have a wall thickness that is greater than the wall thickness of the second portion **763** and the third portion **766** of the collapsible portion **753**. Additionally, the second edge **773** may be recessed inward with 25 respect to the closet collar adapter **113**. The base **756** may further include a first portion **776** and a second portion **779**. The wall for the first portion **776** of the base **756** may be thinner than the wall for the second portion **779** of the base.

Turning to FIG. **33C**, shown is another embodiment of the closet collar adaptation assembly **200** for which the closet collar adapter **113** of FIG. **33A** is being used. As shown, the lip **750** of the closet collar adapter **113** may be disposed between the sealing washer **119** and the adapter plate **503**. The base **756** of the closet collar adapter may be seated on the closet collar **100**. One or more flexible rings **555** may be 40 disposed between the closet collar adapter **113** and the flooring **103** as shown.

With reference to FIG. **33D**, shown is a portion of the closet collar adaptation assembly **200** of FIG. **33B** for the case in which a single flexible ring **555** is being used. As shown, the collapsible portion **753** of the closet collar adapter **113** has partially collapsed. In particular, the first portion **776** of the base **756** may flex and thereby facilitate the base **756** displacing downward. Additionally, the third 45 edge **774** of the collapsible portion **753** may flex and facilitate the third portion **766** of the collapsible portion **753** displacing downward. Thus, a vertical distance between the third edge **774** and the second edge **773** may decrease.

The second portion **763** of the collapsible portion **753** may extend inward and downward by flexing about the second edge **773** and the first edge **769**. As such, a vertical distance between the first edge **769** and the second edge **773** may decrease. Additionally, the first edge **769** may flex and facilitate the lip **750** and the first portion of the collapsible 50 portion **753** displacing downward.

Turning now to FIG. **33E**, shown is a portion of the closet collar adapter **113** collapsed, for example, in the event that a flexible ring **555** (**33D**) is not being used in conjunction with the closet collar adaptation assembly **200** (FIG. **33D**).

It is emphasized that the above-described embodiments of the present disclosure are merely possible examples of implementations set forth for a clear understanding of the



## 13

principles of the disclosure. Many variations and modifications may be made to the above-described embodiment(s) without departing substantially from the spirit and principles of the disclosure. All such modifications and variations are intended to be included herein within the scope of this disclosure.

Therefore, the following is claimed:

1. A toilet system, comprising:
  - a drain pipe;
  - a closet collar coupled to the drain pipe, the closet collar comprising a flange;
  - a toilet positioned over the closet collar, the toilet comprising a horn that extends from an underside of the toilet; and
  - a toilet seal assembly positioned between the toilet and the closet collar, the toilet seal assembly providing a seal between the toilet and the flange of the closet collar, the toilet seal assembly comprising:
    - a flexible rubber seal comprising:
      - a flexible rubber annular wall;
      - a rubber upper ring affixed to the flexible rubber annular wall that extends radially inward from the flexible rubber annular wall, the rubber upper ring making direct contact with the horn of the toilet that extends from the underside of the toilet;
      - a rubber lower ring affixed to the flexible rubber annular wall that extends radially outward from the flexible rubber annular wall, the rubber lower ring making direct contact with the flange of the closet collar; and
      - a rubber funnel portion that extends from the flexible rubber annular wall into the closet collar; and
      - a compressible foam seal ring disposed on the rubber lower ring of the flexible rubber seal, the compressible foam seal ring circumscribing at least a portion of the flexible rubber annular wall of the flexible rubber seal.
  2. The toilet system of claim 1, further comprising an additional compressible foam seal ring disposed directly on the compressible foam seal ring.
  3. The toilet system of claim 1, wherein the flexible rubber annular wall comprises a collapsible wall.
  4. The toilet system of claim 3, wherein the flexible rubber annular wall comprises a pleated bellow.
  5. The toilet system of claim 1, wherein the rubber upper ring is at least a portion of a sealing washer.
  6. The toilet system of claim 1, wherein the rubber lower ring is a flexible lip.
  7. The toilet system of claim 1, wherein the rubber upper ring is flexed downward toward the closet collar by the horn of the toilet.
  8. The toilet system of claim 1, wherein at least a portion of the rubber funnel portion forms a ridge.
  9. The toilet system of claim 1, wherein at least a portion of the rubber funnel portion forms a pipe extension.
  10. The toilet system of claim 1, further comprising a plurality of anchor bolts that extend through a plurality of corresponding holes in the toilet seal assembly.
  11. A toilet seal assembly, comprising:
    - a flexible rubber seal comprising:
      - a flexible rubber annular wall;
      - a flexible rubber upper ring affixed to the flexible rubber annular wall that extends radially inward from the flexible rubber annular wall, the flexible rubber upper ring being configured to make direct contact with a horn of a toilet that extends from an

## 14

- underside of the toilet when the toilet is positioned over the flexible rubber seal; and
- a flexible rubber lower ring affixed to the flexible rubber annular wall that extends radially outward from the flexible rubber annular wall, the flexible rubber lower ring being configured to make direct contact with a flange of a closet collar that couples to a drain pipe; and
- a compressible foam seal ring disposed on the flexible rubber lower ring such that the compressible foam seal ring circumscribes at least a portion of the flexible rubber annular wall of the flexible rubber seal.
12. The toilet seal assembly of claim 11, further comprising a flexible rubber funnel portion that extends from the flexible rubber annular wall.
13. The toilet seal assembly of claim 11, wherein the flexible rubber annular wall is collapsible.
14. The toilet seal assembly of claim 11, wherein all of the flexible rubber seal is molded as a single component.
15. The toilet seal assembly of claim 11, wherein the flexible rubber upper ring is configured to be flexed by the horn of the toilet.
16. The toilet seal assembly of claim 11, wherein the compressible foam seal ring is flexible.
17. The toilet seal assembly of claim 11, further comprising an additional compressible foam seal ring disposed on the compressible foam seal ring.
18. The toilet seal assembly of claim 11, wherein the compressible foam seal ring comprises a flat upper surface and a flat lower surface.
19. The toilet seal assembly of claim 11, wherein the toilet seal assembly is compatible with a plurality of closet collars installed at various heights relative to the surrounding flooring.
20. A toilet seal assembly, comprising:
  - a flexible rubber seal comprising:
    - a flexible rubber annular wall;
    - a rubber upper ring affixed to the flexible rubber annular wall that extends radially inward from the flexible rubber annular wall, the rubber upper ring being configured to make direct contact with a horn of a toilet that extends from an underside of the toilet; and
    - a rubber lower ring affixed to the flexible rubber annular wall that extends radially outward from the flexible rubber annular wall, the rubber lower ring being configured to make direct contact with a flange of a closet collar that couples to a drain pipe; and
    - a compressible seal ring disposed on the rubber lower ring, the compressible seal ring circumscribing at least a portion of the flexible rubber annular wall of the flexible rubber seal.
  21. The toilet seal assembly of claim 20, wherein the flexible rubber seal further comprises a flexible rubber funnel portion that extends from the flexible rubber annular wall, the flexible rubber funnel portion being configured to extend into the closet collar when the rubber lower ring of the flexible rubber flexible seal makes direct contact with the flange of the closet collar.
  22. The toilet seal assembly of claim 20, wherein all of the flexible seal is rubber.
  23. The toilet seal assembly of claim 20, wherein the compressible seal ring is a foam seal ring.
  24. The toilet seal assembly of claim 20, wherein the flexible rubber annular wall comprises a collapsible wall.
  25. The toilet seal assembly of claim 20, wherein the rubber upper ring is flexible and configured to be flexed by



15

the horn of the toilet, and wherein the flexible seal is configured such that at least a portion of the rubber upper ring contacts at least a portion of the flexible rubber annular wall when the horn of the toilet flexes the rubber upper ring.

26. The toilet seal assembly of claim 20, wherein the rubber lower ring is a flexible lip.

27. The toilet seal assembly of claim 20, wherein the compressible seal ring comprises a flat upper surface and a flat lower surface.

28. The toilet seal assembly of claim 20, further comprising an additional compressible seal ring configured to be disposed on the compressible seal ring.

29. The toilet seal assembly of claim 20, wherein the toilet seal assembly is compatible with a plurality of closet collars installed at various heights relative to the surrounding flooring.

30. A method, comprising:

positioning a toilet seal assembly on a closet collar coupled to a drain pipe, the toilet seal assembly comprising a flexible rubber seal and a compressible foam seal ring, the flexible rubber seal comprising a collapsible rubber annular wall, a flexible rubber upper ring affixed to the collapsible rubber annular wall that extends radially inward from the collapsible rubber

16

annular wall, a flexible rubber lower ring affixed to the collapsible rubber annular wall that extends radially outward from the collapsible rubber annular wall, and a flexible rubber funnel portion that extends from the collapsible rubber annular wall, the compressible foam seal ring being disposed directly on the flexible rubber lower ring of the flexible rubber seal and circumscribing at least a portion of the collapsible rubber annular wall of the flexible rubber seal, the toilet seal assembly being positioned on the closet collar such that the flexible rubber lower ring of the flexible rubber seal directly contacts a flange of the closet collar and the flexible rubber funnel portion of the flexible rubber seal extends into the closet collar;

positioning a toilet on the toilet seal assembly such that a horn on an underside of the toilet makes direct contact with the flexible rubber upper ring of the flexible rubber seal and cause the flexible rubber upper ring to be flexed downward towards the flexible rubber lower ring; and

fastening a plurality of bolts that extend through the flange of the closet collar, the toilet seal assembly and the toilet.

\* \* \* \* \*