



(12) **United States Patent**
James et al.

(10) **Patent No.:** **US 10,995,939 B2**
(45) **Date of Patent:** ***May 4, 2021**

(54) **REMOVABLE POSITIONING OF LIGHT FIXTURES**

(71) Applicant: **AXIS LIGHTING INC.**, Lasalle (CA)

(72) Inventors: **Thomas James**, Lasalle (CA); **Howard Yaphe**, Lasalle (CA); **Andrew Miles**, Lasalle (CA)

(73) Assignee: **Axis Lighting Inc.**, LaSalle (CA)

(*) Notice: Subject to any disclaimer, the term of this patent is extended or adjusted under 35 U.S.C. 154(b) by 0 days.

This patent is subject to a terminal disclaimer.

(21) Appl. No.: **16/676,109**

(22) Filed: **Nov. 6, 2019**

(65) **Prior Publication Data**

US 2020/0141563 A1 May 7, 2020

Related U.S. Application Data

(63) Continuation of application No. 15/909,457, filed on Mar. 1, 2018, now Pat. No. 10,473,307.

(60) Provisional application No. 62/532,970, filed on Jul. 14, 2017, provisional application No. 62/521,795, filed on Jun. 19, 2017.

(51) **Int. Cl.**

F21V 21/04 (2006.01)
F21S 8/02 (2006.01)
F21S 8/04 (2006.01)
F21Y 103/00 (2016.01)

(52) **U.S. Cl.**

CPC **F21V 21/045** (2013.01); **F21S 8/026** (2013.01); **F21V 21/048** (2013.01); **F21S 8/043** (2013.01); **F21Y 2103/00** (2013.01)

(58) **Field of Classification Search**

CPC F21V 21/044-049
See application file for complete search history.

(56) **References Cited**

U.S. PATENT DOCUMENTS

3,512,313 A 5/1970 Harz
3,704,906 A 12/1972 Abercrombie
(Continued)

FOREIGN PATENT DOCUMENTS

KR 20110003394 U 4/2011

OTHER PUBLICATIONS

XAL Inc., "Leno—Zero Plenum Luminaire," (Apr. 29, 2015).
U.S. Appl. No. 15/909,457, filed Mar. 1, 2018.

Primary Examiner — Alexander K Garlen

(74) *Attorney, Agent, or Firm* — Barnes & Thornburg LLP

(57) **ABSTRACT**

A linear light fixture assembly for supporting a light fixture in a ceiling structure, comprises a light fixture mounting structure having a pair of opposed boundary regions configured to fit within a designated light fixture receiving region in the ceiling structure, and a plurality of spring elements configured to spaced outwardly from at least one of the boundary regions, each spring element having a mounting region configured to be anchored to the mounting structure and a free end region to extend therefrom and to be laterally outwardly biased in a first position to form a path of contact with a support surface region on the ceiling structure to anchor the structure in the receiving region, each of the spring elements configured to be movable toward the corresponding boundary region in a second position to release the path of contact to release the light fixture from the receiving region.

10 Claims, 12 Drawing Sheets

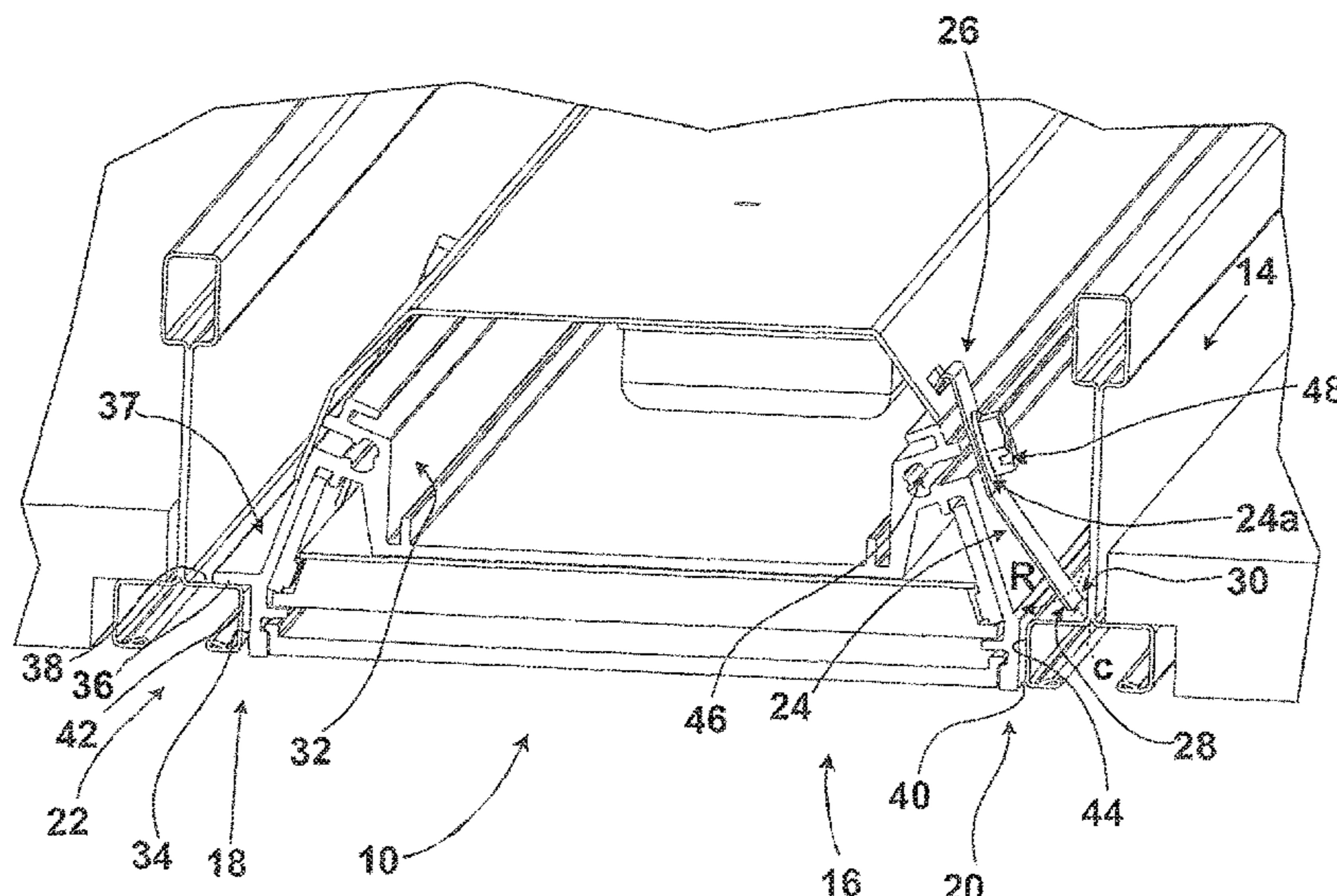

(56)

References Cited

U.S. PATENT DOCUMENTS

3,918,751	A	11/1975	Blake	
4,043,689	A	8/1977	Spencer et al.	
4,449,166	A	5/1984	Sharp	
5,997,158	A	12/1999	Fischer	
D669,208	S	10/2012	Hierzer et al.	
RE45,162	E	9/2014	Hierzer	
9,206,948	B1	12/2015	Scribante	
2008/0086962	A1	4/2008	Jahn	
2010/0213654	A1	8/2010	Lin	
2011/0176295	A1	7/2011	Chang et al.	
2011/0235342	A1	9/2011	Liang	
2011/0239503	A1	10/2011	Liao	
2012/0020067	A1	1/2012	Mai	
2012/0182744	A1*	7/2012	Santiago	F21S 8/026 362/365
2014/0268829	A1	9/2014	Mandy	
2015/0085476	A1	3/2015	Mandy	
2016/0010817	A1	1/2016	Hierzer	
2016/0138788	A1	5/2016	Sareyka et al.	
2017/0356605	A1	12/2017	Hierzer	

* cited by examiner

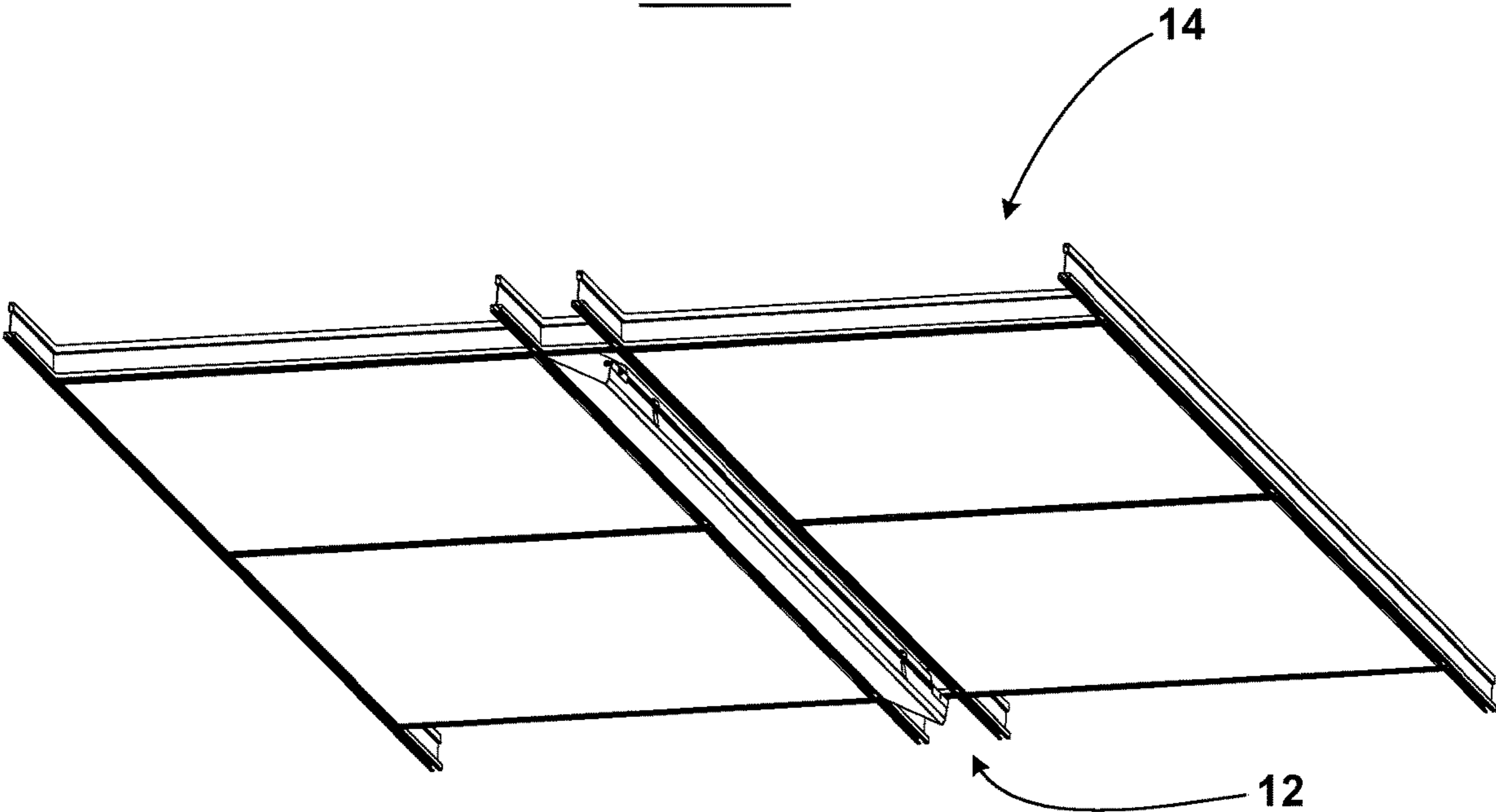
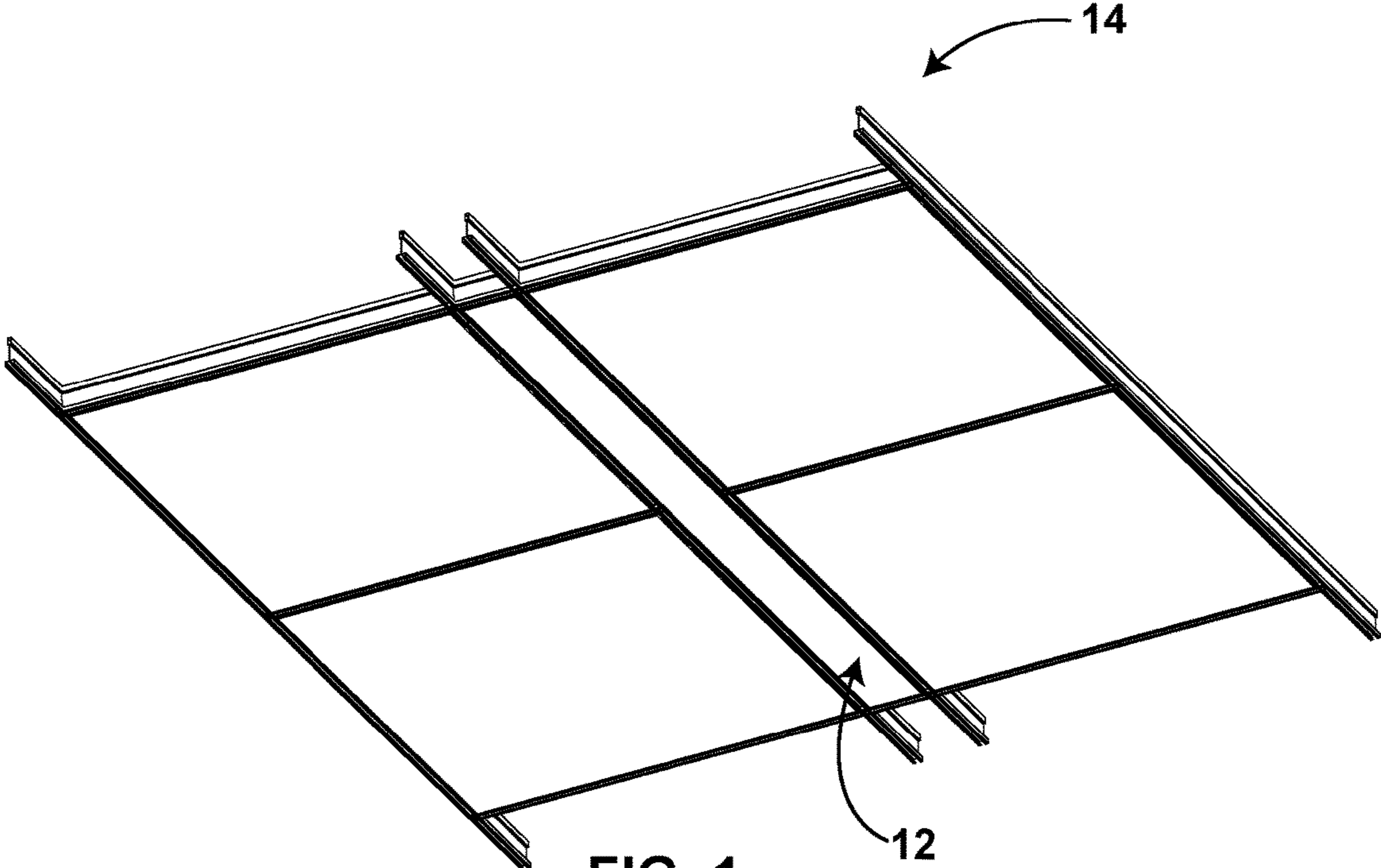

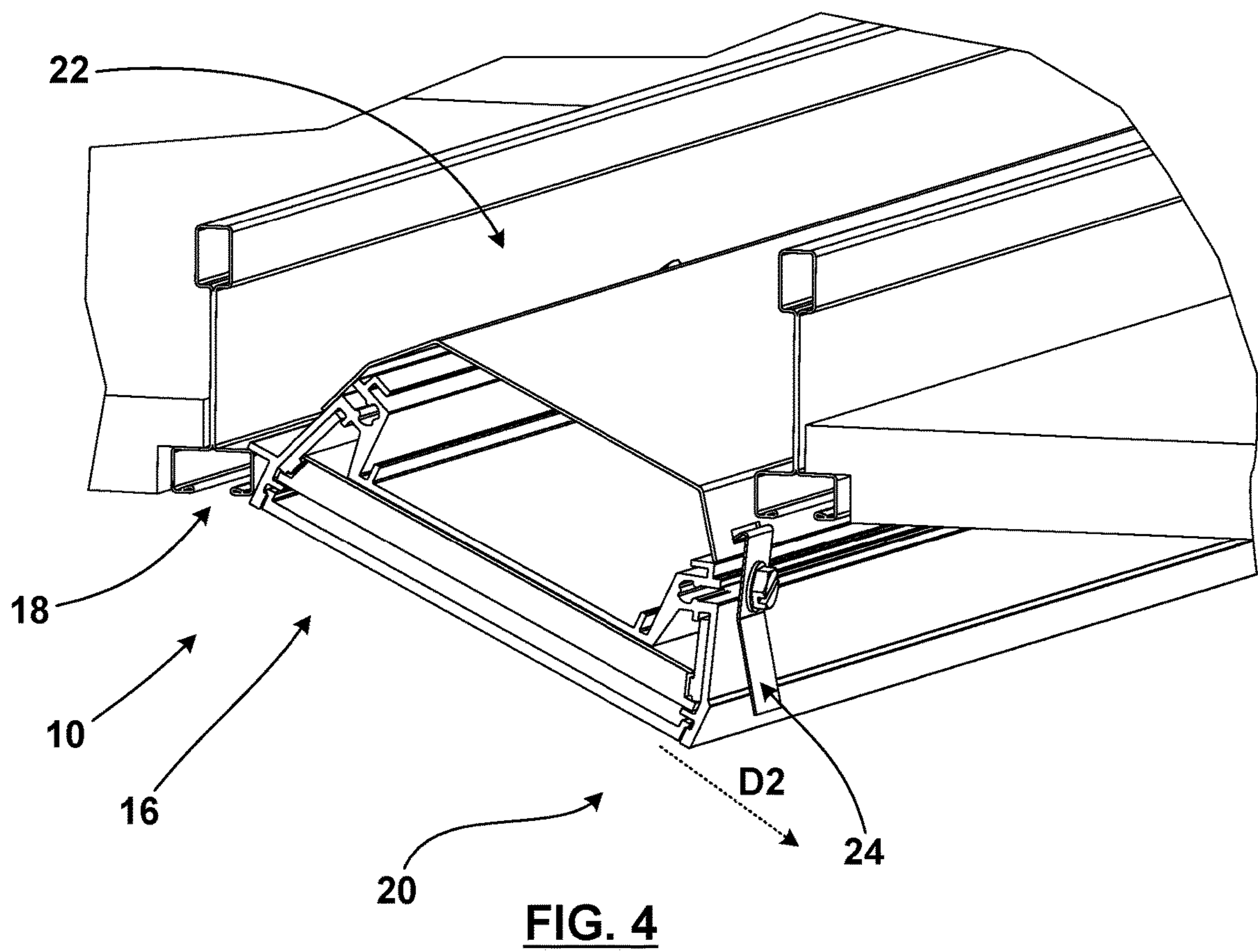
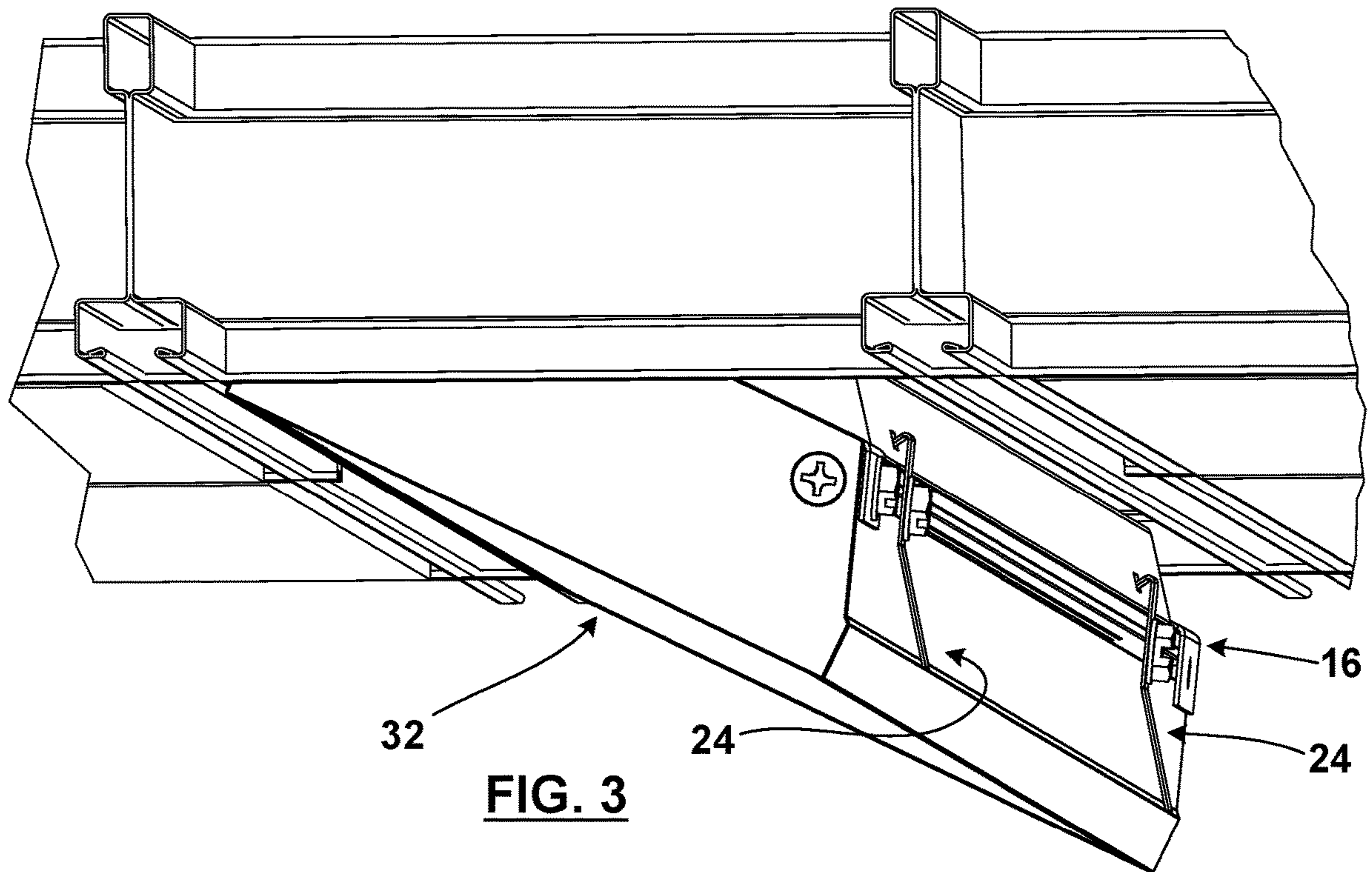

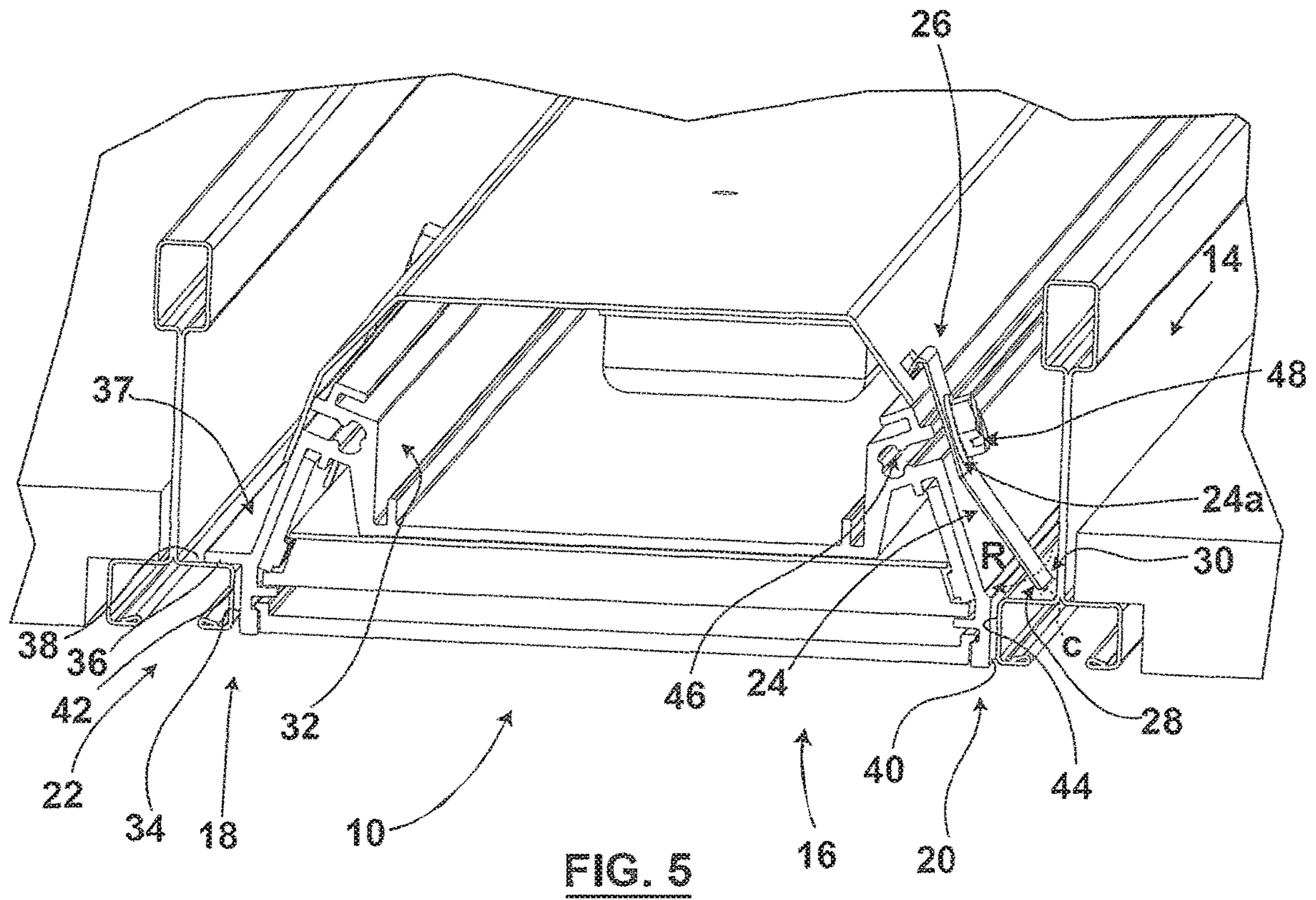

FIG. 5

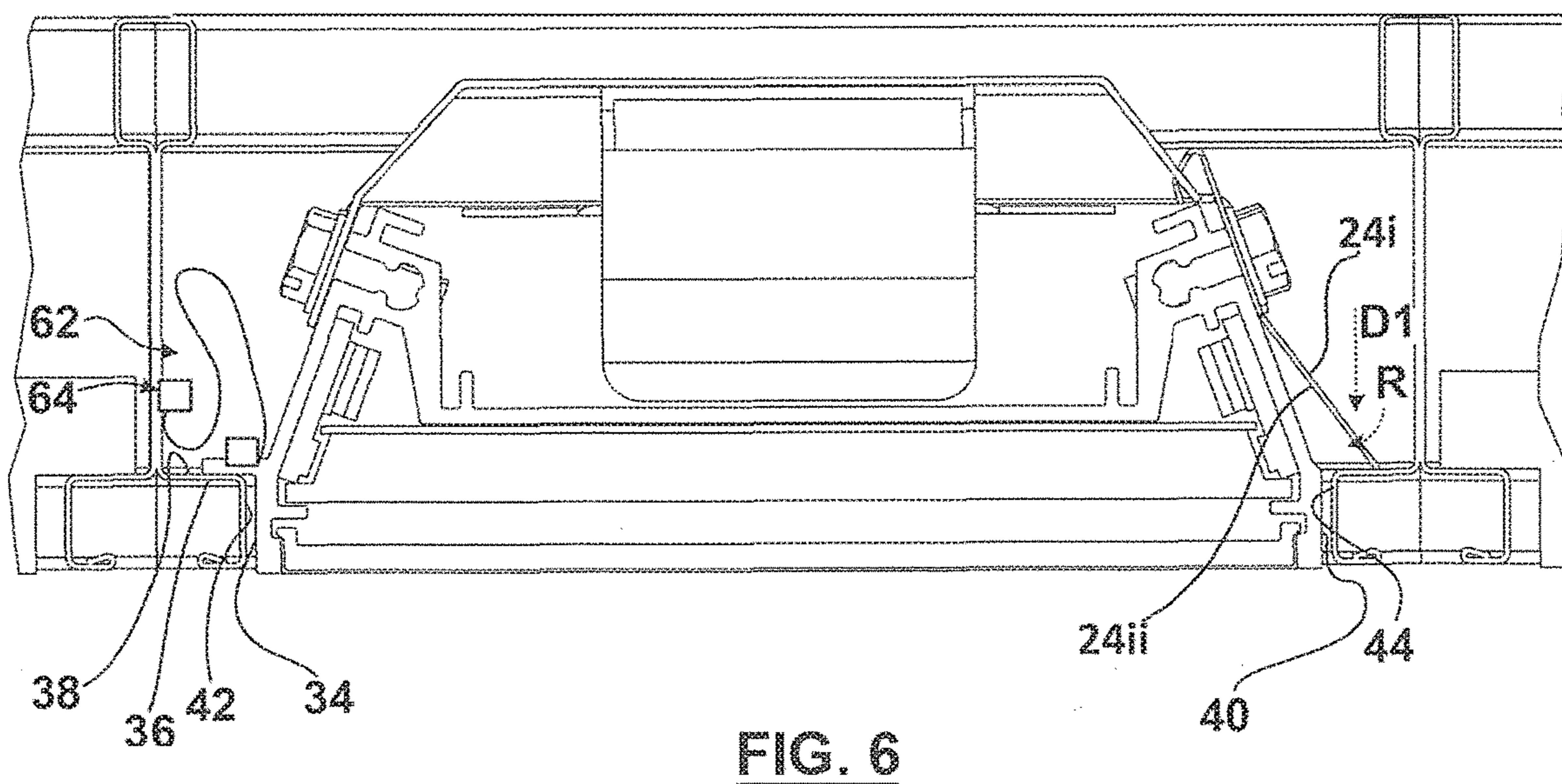

FIG. 6

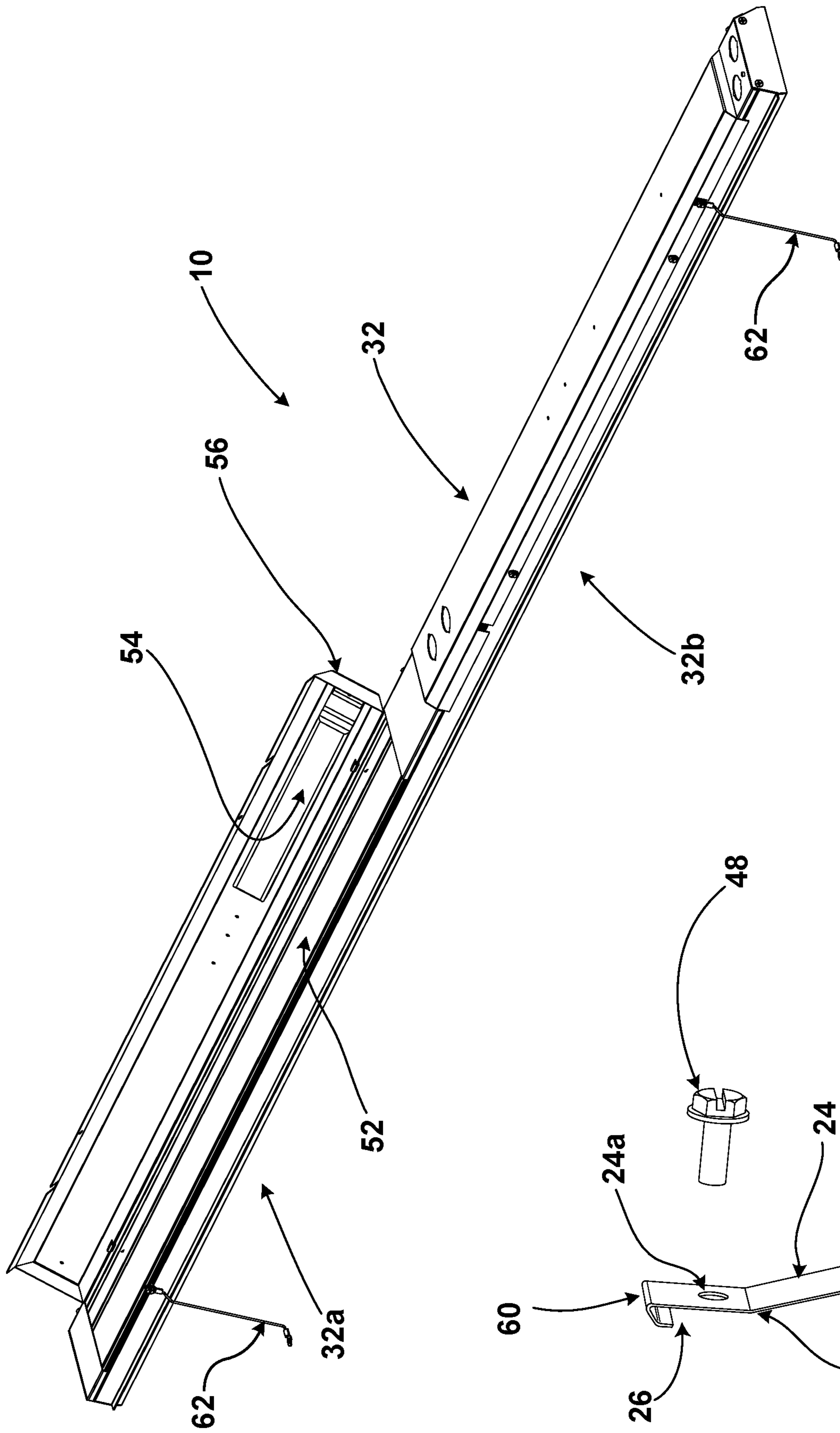

FIG. 8

FIG. 7

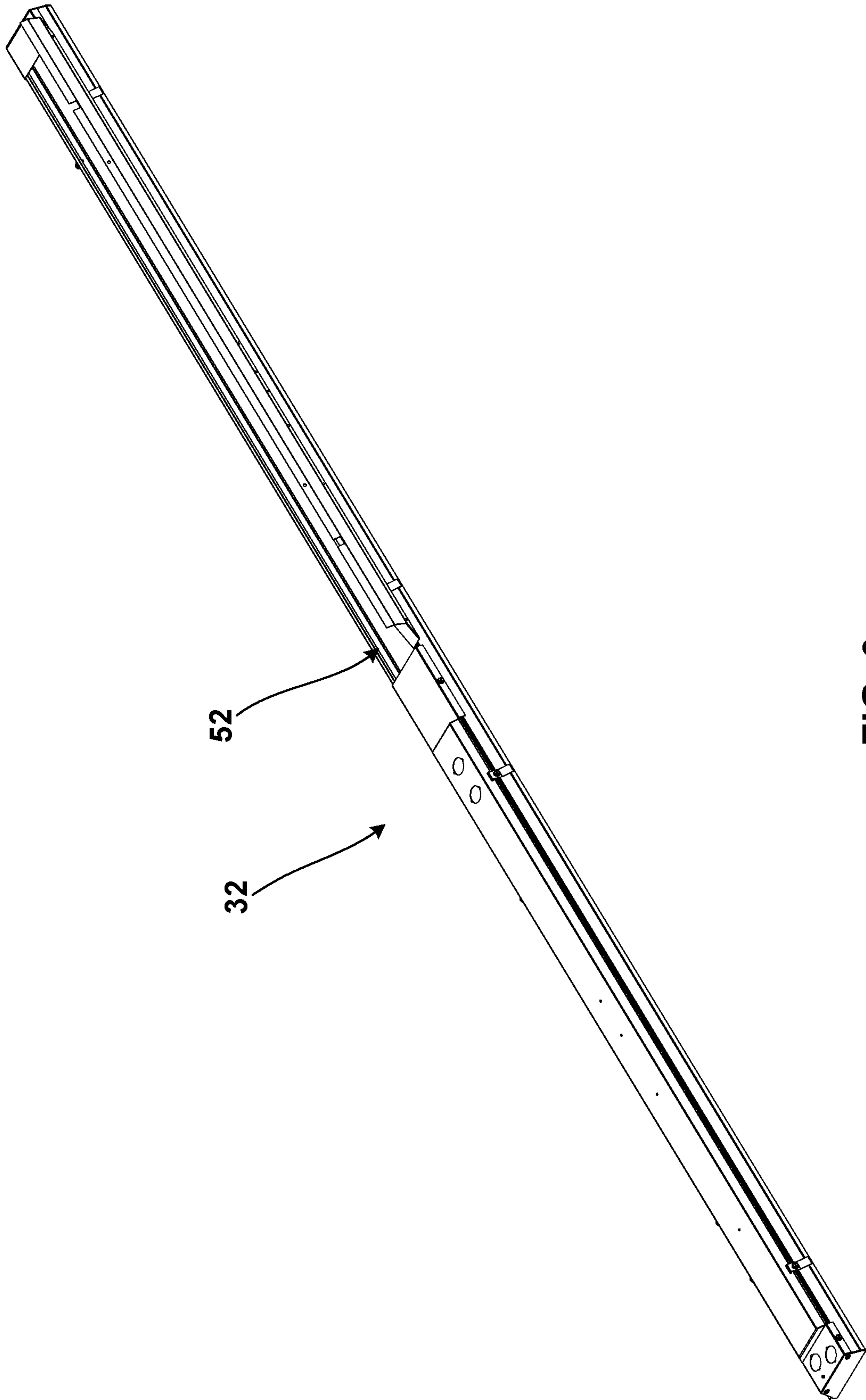

FIG. 9

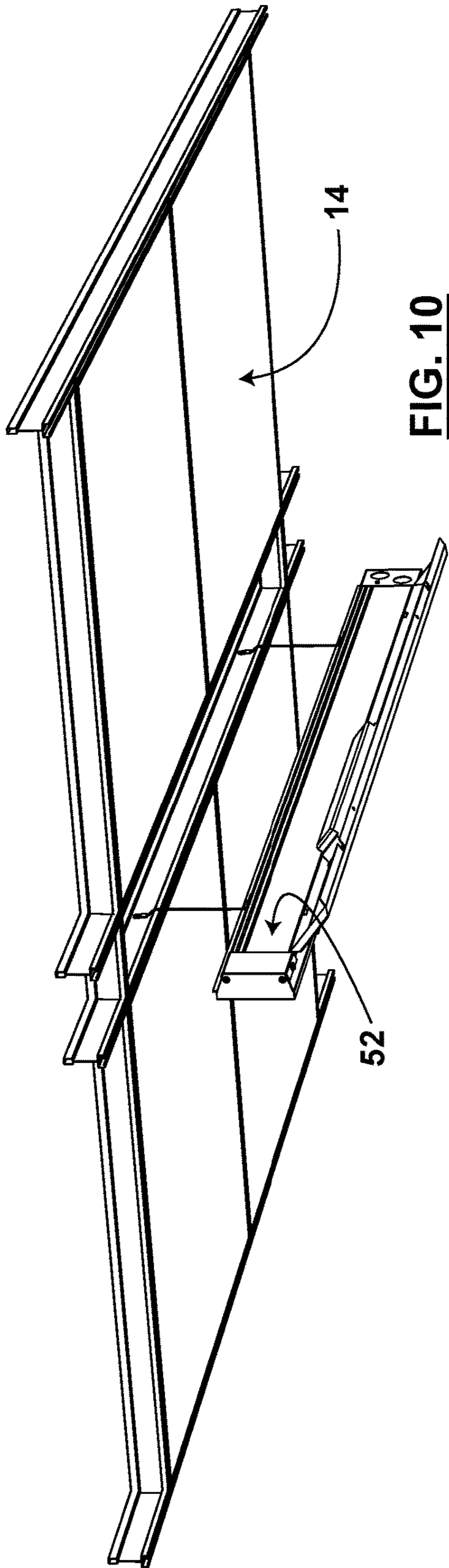

FIG. 10

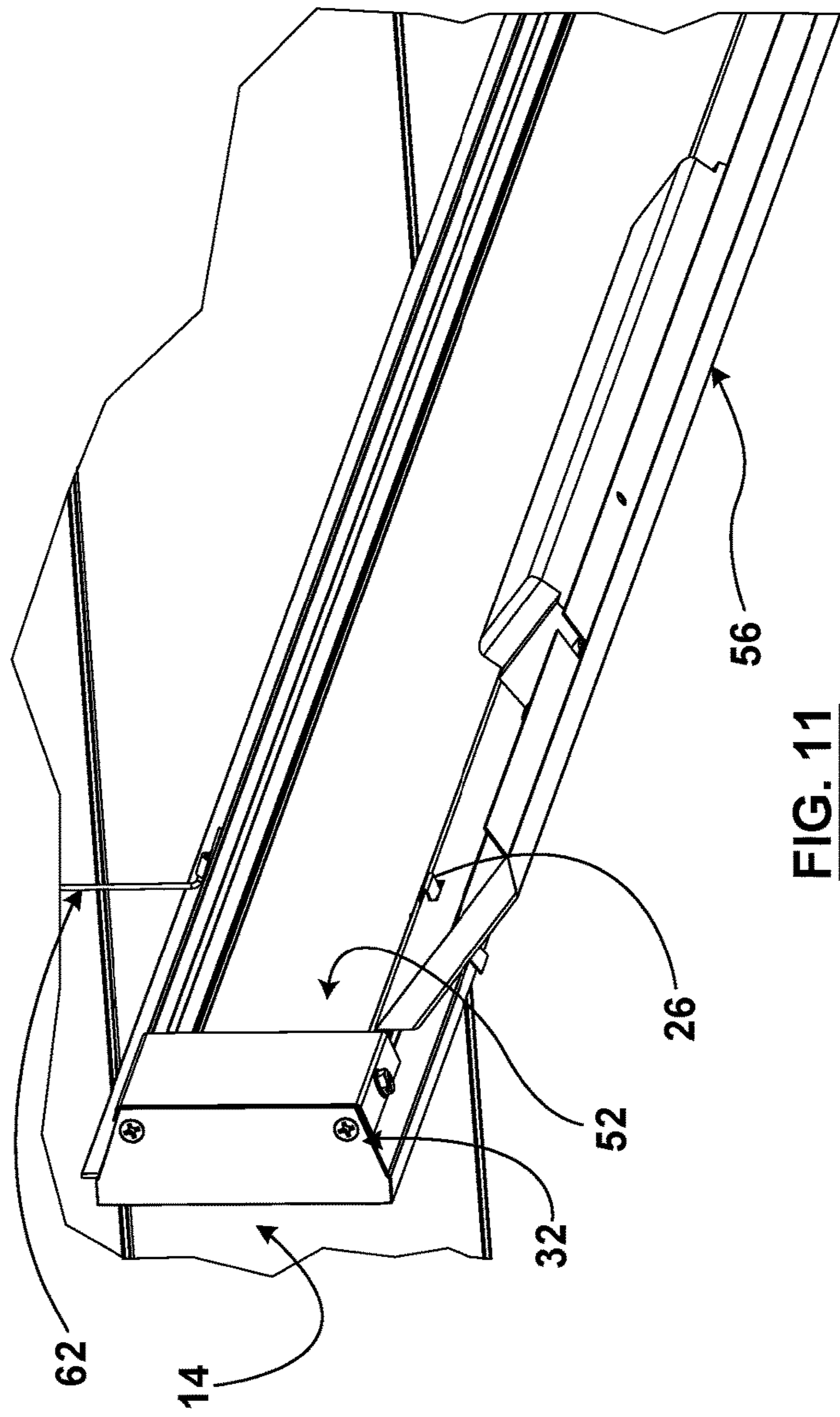

FIG. 11

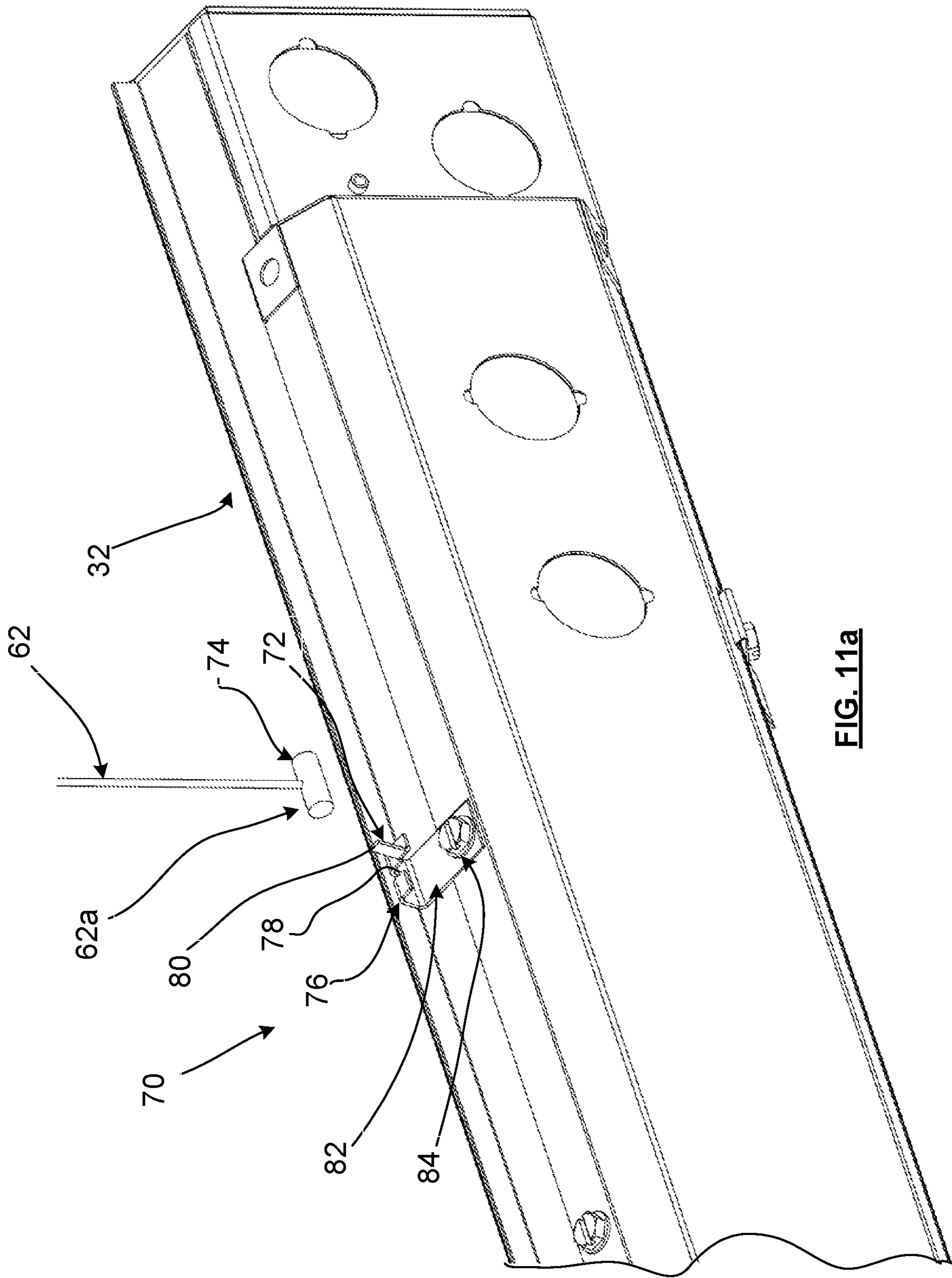

FIG. 11a

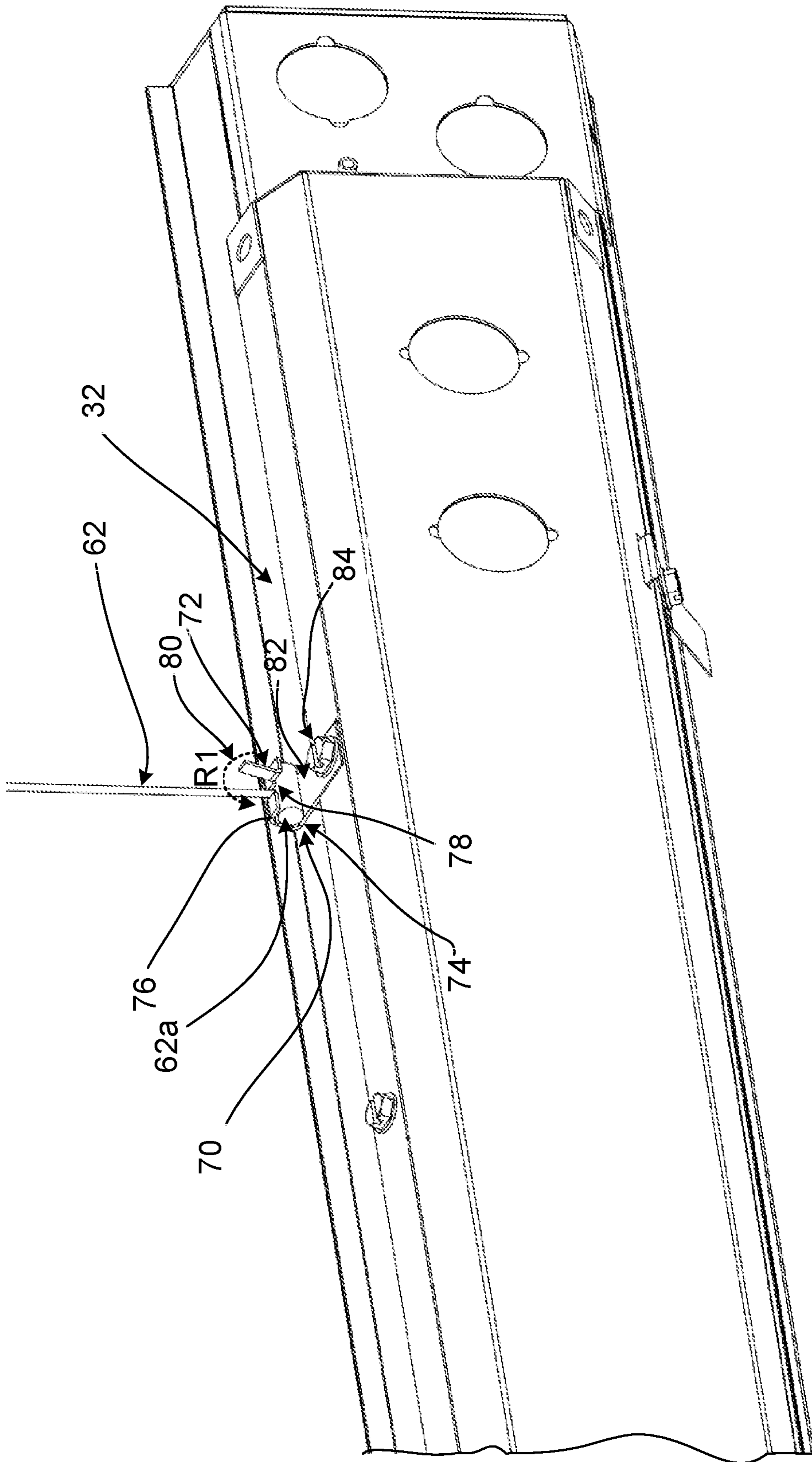

FIG. 11b

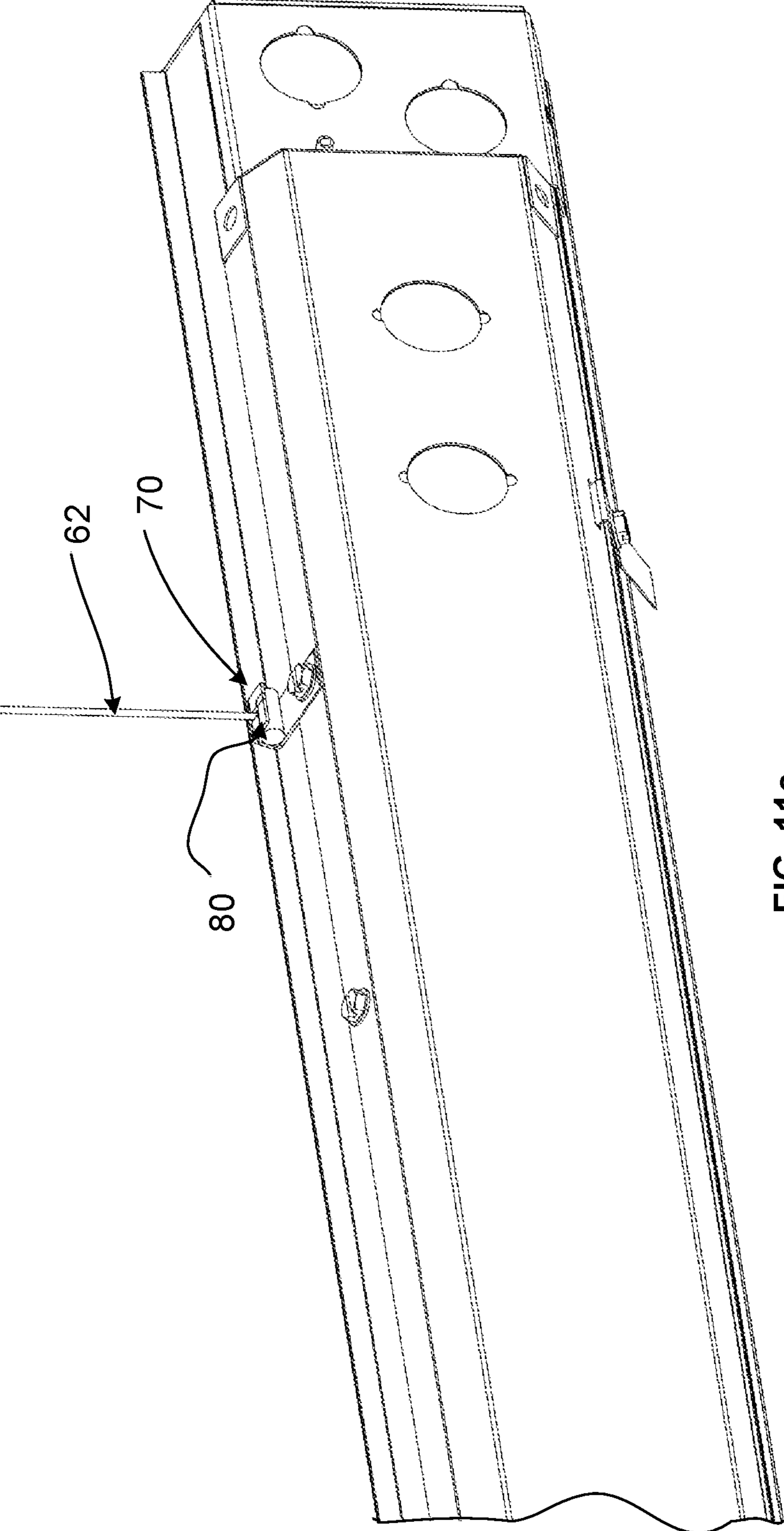
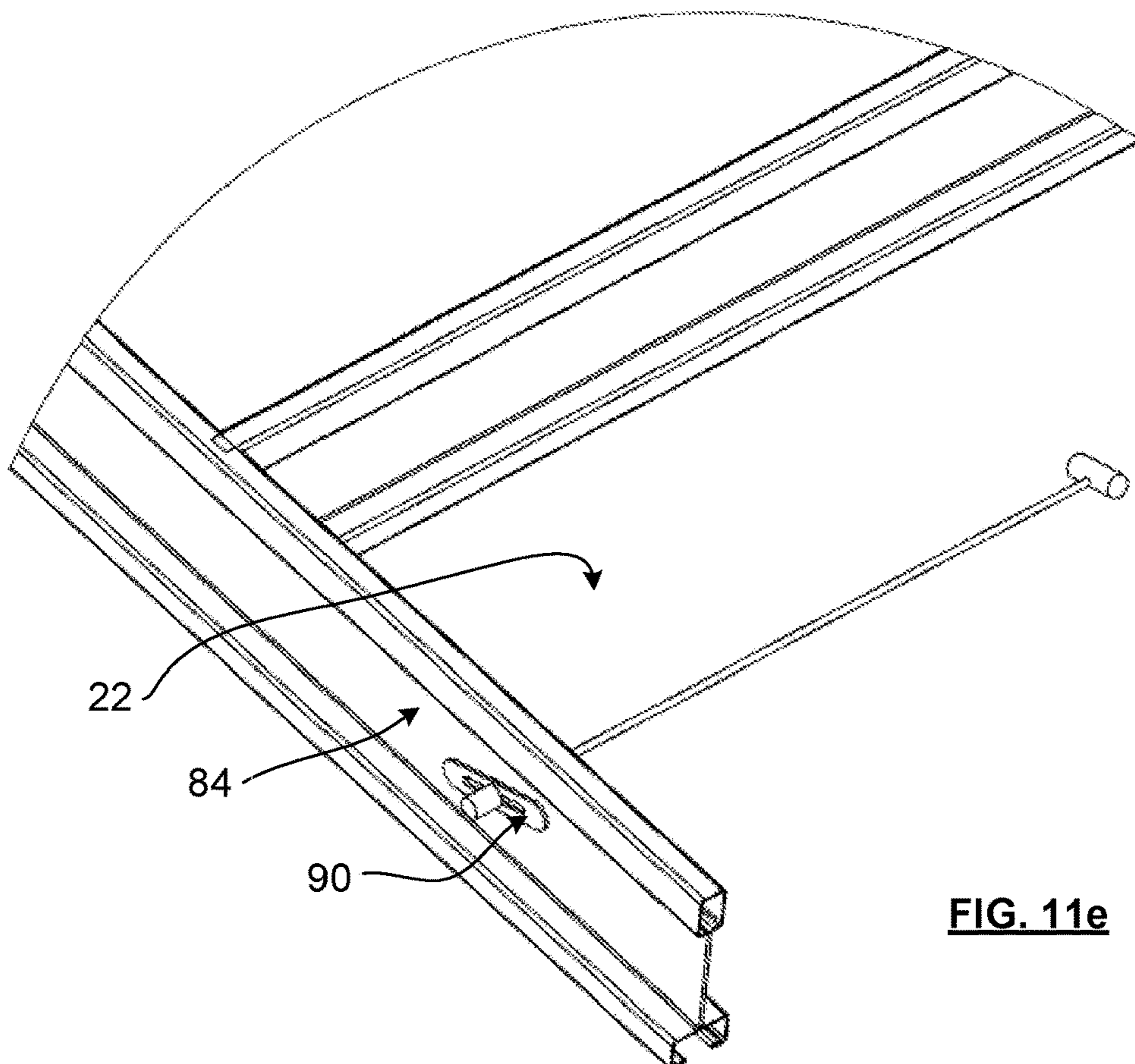
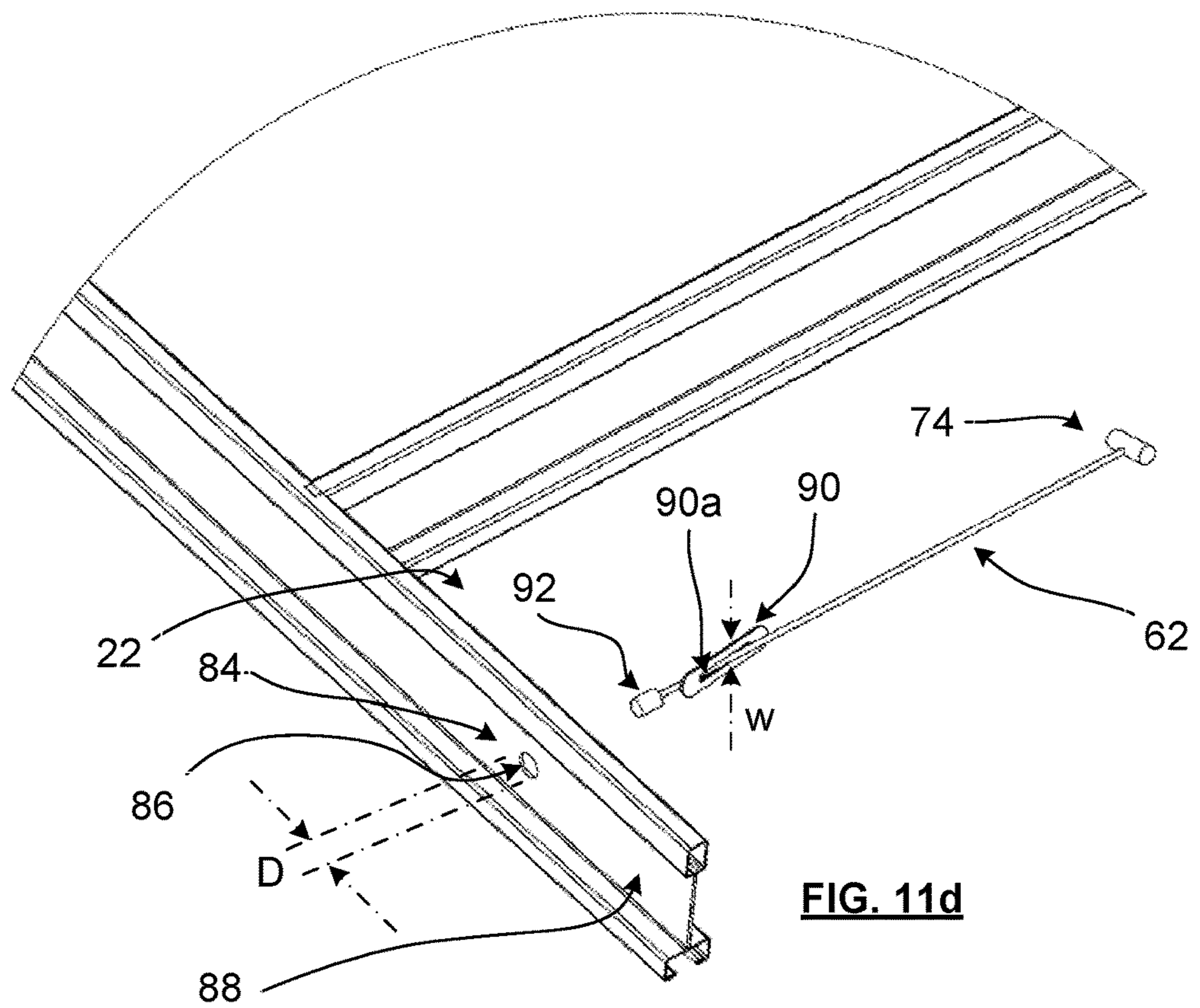

FIG. 11C



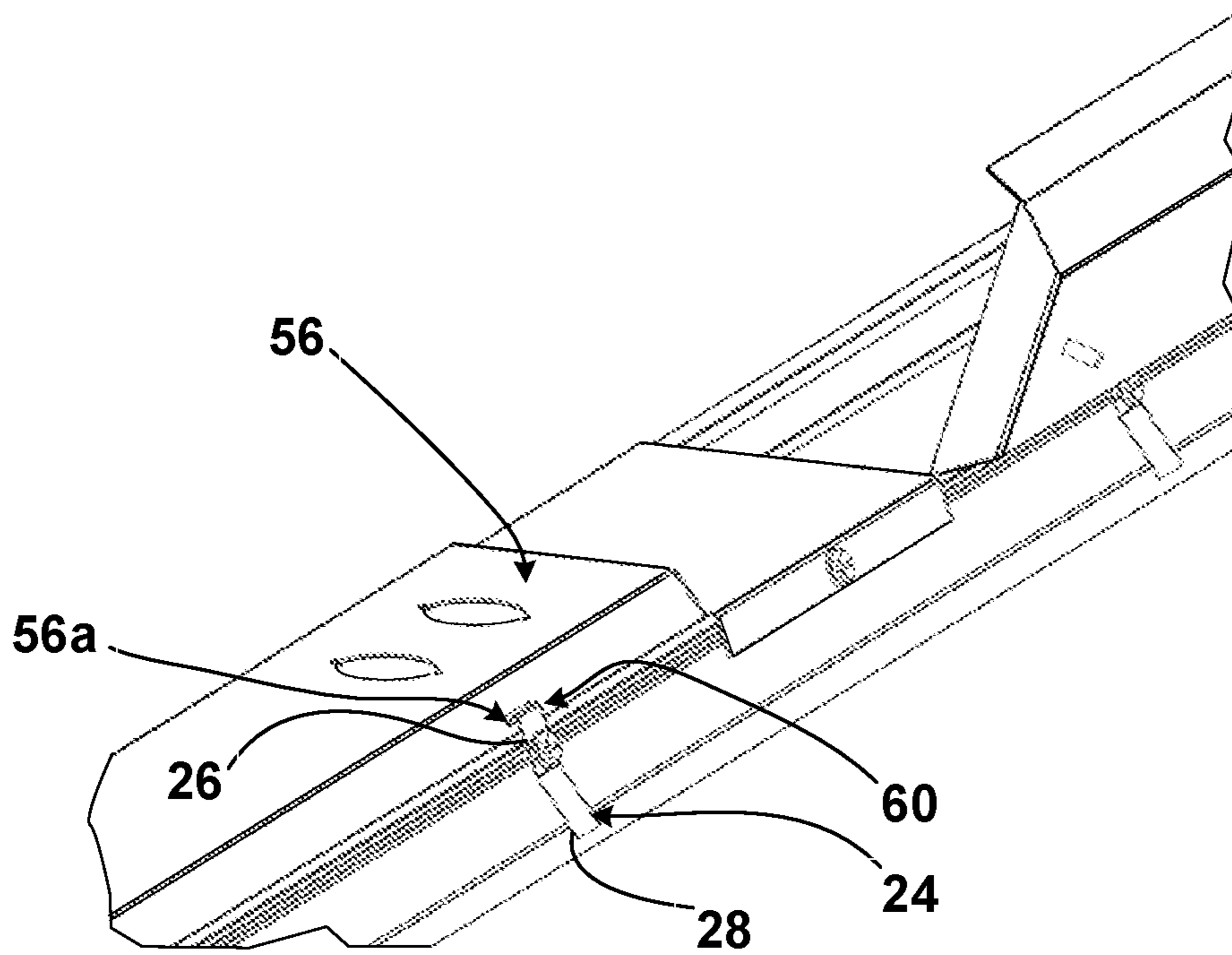

FIG. 12

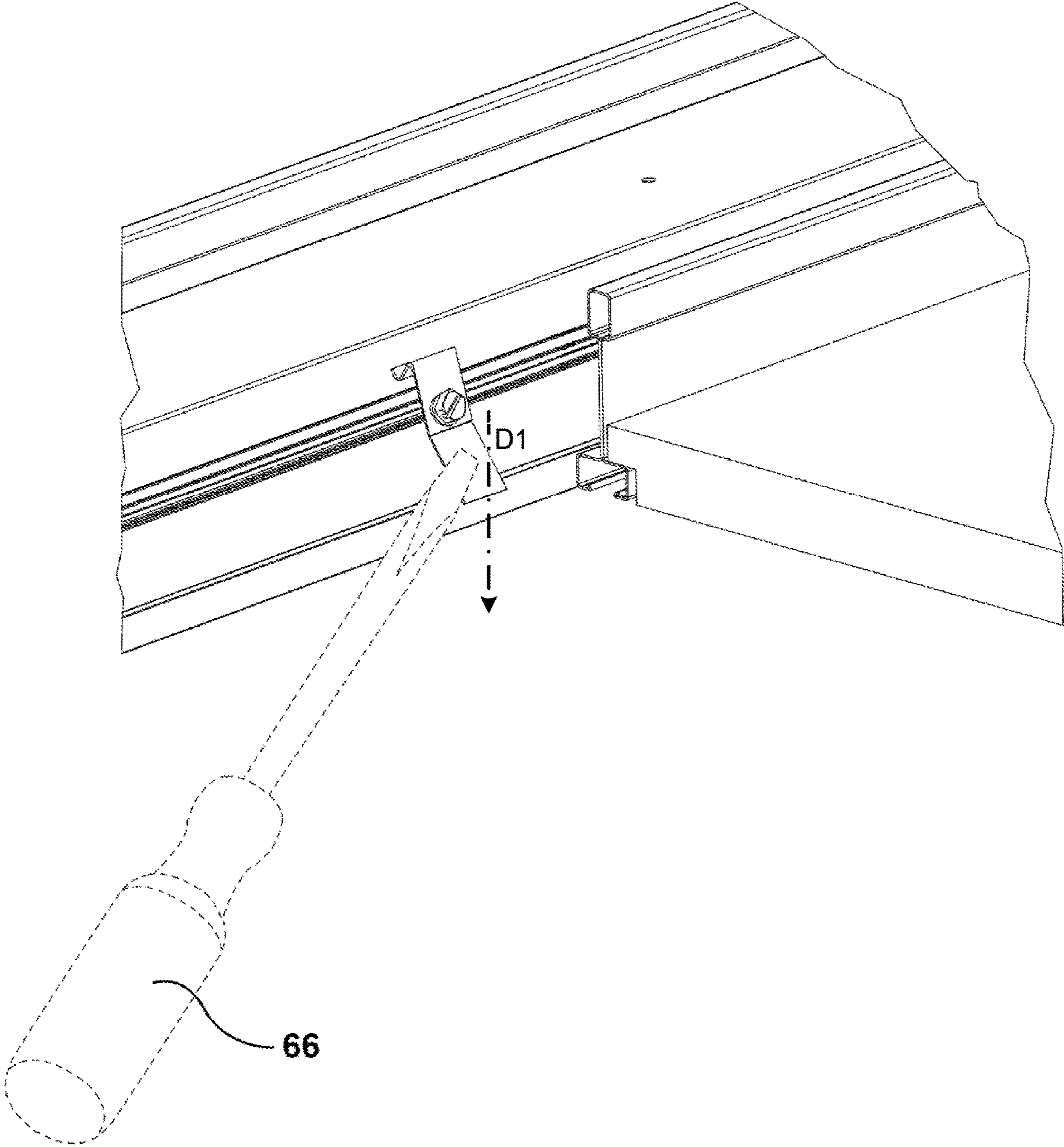

FIG. 13

REMOVABLE POSITIONING OF LIGHT FIXTURES

REFERENCE TO CO-PENDING APPLICATION

This application is a Continuation of U.S. application Ser. No. 15/909,457, filed Mar. 1, 2018, which claims the benefit of priority under 35 U.S.C. § 119(e) to U.S. Provisional Patent Application No. 62/521,795, filed Jun. 19, 2017, entitled REMOVABLE POSITIONING OF LIGHT FIXTURES, and U.S. Provisional Patent Application No. 62/532,970, filed Jul. 14, 2017, entitled REMOVABLE POSITIONING OF LIGHT FIXTURES. The disclosures set forth in the referenced applications are incorporated herein by reference in their entireties.

FIELD OF THE DISCLOSURE

The present disclosure relates to light fixtures and other ceiling mountable articles and, for example, to methods and devices for positioning light fixtures in ceiling structures.

BACKGROUND

Light fixtures are widely used in ceiling structures formed from ceiling support grids made with t-bars or other supporting grid members. Installation involves forming the grid with a present a light fixture receiving region, usually with opposed exposed horizontal surfaces to engage opposed sides of the light fixtures, which are configured with releasable attachment mechanisms that permit them to be installed in the light fixture receiving region. Examples of such light fixtures are shown in US 2016/0010817 A1 to HIERZER, and US 2016/0138788 to Sareyka et al. In both instances, the releasable attachment mechanisms rely on releasable catches, akin to door latches or the like formed with a sloping edge portion and spring loaded. However, these mechanisms are relatively bulky and can be tedious to release. Furthermore, ongoing maintenance requires access to the light fixture either from above the ceiling structure, which can be limited in many cases, or complete removal of the fixture from the ceiling structure.

It may thus be desirable to provide novel approaches for positioning light fixtures in ceiling structures, or at least to provide the public with one or more useful alternatives.

SUMMARY

In an aspect, there is provided a light fixture assembly for supporting a light fixture in a ceiling structure. The assembly comprises a light fixture mounting structure having a pair of opposed boundary regions configured to fit within a designated light fixture receiving region in the ceiling structure, and a plurality of spring elements configured to be spaced outwardly from at least one of the boundary regions. Each spring element comprises a mounting region configured to be anchored to the mounting structure and a free end region to extend therefrom and to be laterally outwardly biased in a first position to form a path of contact with a support surface region on the ceiling structure to anchor the mounting structure in the receiving region. Each of the spring elements is configured to be movable toward the corresponding boundary region in a second position to release the path of contact to release the mounting structure from the receiving region.

In some exemplary embodiments, the light fixture mounting structure may be integrally formed with a light fixture body.

In some exemplary embodiments, the light fixture body may comprise a first boundary region which presents at least one support surface to engage a corresponding support surface on the ceiling structure, and a second boundary region with the plurality of spring elements to be positioned therealong.

In some exemplary embodiments, the second boundary region may include a recess to receive an anchor fastener extending through the mounting region of a corresponding spring element, for anchoring the spring element therealong.

In some exemplary embodiments each spring element may be provided as a flat spring.

In some exemplary embodiments, each spring element may include an opening to receive the anchor fastener, and a bend region adjacent the opening to delineate the mounting and free end regions.

In some exemplary embodiments, the light fixture body may define an opening, and further comprises a cover to close the opening. Each spring element may further comprise a hinge region adjacent the mounting region and opposite the free end region. The cover may be configured to engage the hinge region for movement of the cover relative thereto.

In some exemplary embodiments, the cover may include a number of hinge openings, each to receive a hinge region of a corresponding spring element. The hinge region may be hook shaped in cross section in some examples.

Some exemplary embodiments may further comprise one or more suspension structures to suspend the light fixture body when in a servicing mode with the opening laterally oriented below the ceiling structure for servicing.

In some exemplary embodiments, the cover may be configured to pivot relative to the hinge region toward an open position in which the cover is oriented below the light fixture body when in the servicing mode.

In some exemplary embodiments, the suspension structures may comprise at least two cables, ropes, chains and/or linkages, each of which is configured to be anchored between the first boundary region and a corresponding location adjacent the light fixture receiving region.

Some exemplary embodiments may further comprise an anchoring structure positionable on the light fixture body and configured to receive an end region of the suspension structure. A locking structure may be provided which is movable from a releasable position to receive a designated mounting location on the suspension structure and a lock position to hold the suspension structure in the anchoring structure.

In some exemplary embodiments, the anchoring structure may include a designated anchoring location to engage the designated mounting location and a locking structure movable between releasable and locked positions to control access to one of said designated mounting and locking locations.

In some exemplary embodiments, the suspension structure may include a cable, and the designated mounting location may be provided by an enlarged cable end structure.

In some exemplary embodiments, the anchoring structure may include a yoke portion to receive the enlarged cable end structure. The yoke portion may further comprise a gap to receive the cable. The locating structure may further comprise a tab configured to extend across the gap in the locking position to hold the cable in the gap.

3

In another aspect, there is provided a linear light fixture mounting structure comprising a pair of opposed boundary regions configured to fit within a designated light fixture receiving region in a ceiling structure. At least one spring element is to extend outwardly from the mounting structure, the at least one spring element having a free end configured to abut a support surface open to the light fixture receiving region, to provide at least one path of contact between the at least one spring element and the support surface to hold the light fixture mounting structure in an operative position in the light fixture receiving region. The at least one spring element is configured to be flexed inwardly toward the light fixture mounting structure to release the free end from the path of contact with the support surface, and thereby to release the light fixture mounting structure from the light fixture receiving region.

In some exemplary embodiments, the at least one spring element may include a plurality of flat springs.

In another aspect, there is provided a linear light fixture for installation in a ceiling structure, comprising an elongate body configured to be received in a light fixture receiving region in the ceiling structure. The elongate body includes an elongate opening when in a servicing mode and an elongate cover hingedly engaged to the elongate body adjacent a first boundary of the elongate opening to cover the opening. One or more suspension structures are configured to be coupled between the body adjacent a second boundary of the opening and the ceiling structure. The light fixture is configured to be releasable from an operative mode in the elongate receiving region to a servicing mode when suspended by the suspension structures below the ceiling structure with the first boundary of the elongate opening positioned below the second boundary, and the cover oriented below the first boundary in the servicing mode to laterally present the opening and/or an inside surface of the cover laterally, thereby to permit servicing of components in the housing and/or on the inside and/or an outside surface of the cover.

In another aspect, there is provided a linear light fixture for installation in a linear light fixture receiving region in a ceiling structure, comprising a linear light fixture body configured to locate in the linear light fixture receiving region in an operative mode. The linear light fixture body comprises a pair of linear light fixture body sections pivotally coupled about a pivot axis along adjacent first longitudinal edge regions thereof. One of the light fixture body sections is configured to be suspended from the ceiling structure at a second longitudinal edge region opposite the first longitudinal edge region thereof, wherein in a servicing mode the linear light fixture body sections open by pivoting relative to the pivot axis to expose opposed inner surfaces on the respective linear light fixture body sections in a lateral direction relative to the ceiling structure to enable serviceable access to components installed in or on one or both of the body sections.

Some exemplary embodiments may further comprise a plurality of suspension structures configured to extend between the ceiling structure and the second longitudinal edge region.

In some exemplary embodiments, the linear light fixture body is configured for attachment to a neighbouring linear light fixture body or an intermediate structure, while in the servicing mode.

In another aspect, there is provided a method of assembling a plurality of linear light fixtures as defined in any aspect, exemplary embodiment or example in the present disclosure or claims, comprising providing a plurality of

4

instances of the linear light fixture, installing each of the instances in the servicing mode by joining a plurality of the suspension structures between each the instances and the corresponding receiving region, joining the instances together directly or indirectly to form a unitary linear light fixture assembly, and installing the unitary linear light fixture assembly in the corresponding receiving region.

BRIEF DESCRIPTION OF THE FIGURES

Several exemplary embodiments of the present disclosure will be provided, by way of examples only, with reference to the appended drawings, wherein:

FIGS. 1 and 2 are perspective views of a light fixture installation in respective configurations;

FIG. 3 is a magnified perspective view of a portion of the installation according to FIG. 2;

FIG. 4 is a magnified perspective sectional view of the installation shown in FIG. 3;

FIG. 5 is a magnified perspective sectional view of a portion of the installation according to FIG. 1;

FIG. 6 is a side view of the portion shown in FIG. 5;

FIG. 7 is an exploded view of components of the installation of FIGS. 5 and 6;

FIGS. 8 and 9 are perspective views of a light fixture assembly of the installation according to FIG. 1 in another configuration;

FIG. 10 is a perspective view of a light fixture installation of FIGS. 1 and 2 in still another configuration;

FIG. 11 is a magnified perspective view of a portion of the installation of FIG. 10;

FIGS. 11a to 11e are fragmentary perspective views of portions of another installation;

FIG. 12 is a magnified perspective view of a portion of the light fixture of FIGS. 8 and 9; and

FIG. 13 is a further magnified perspective view of a portion of the light fixture of FIG. 12 with a tool.

DETAILED DESCRIPTION

It should be understood that the invention is not limited in its application to the details of construction and the arrangement of components set forth in the following description or illustrated in the drawings. The invention is capable of other embodiments and of being practiced or of being carried out in various ways. Also, it is to be understood that the phraseology and terminology used herein is for the purpose of description and should not be regarded as limiting. The use of “including,” “comprising,” or “having” and variations thereof herein is meant to encompass the items listed thereafter and equivalents thereof as well as additional items. Unless limited otherwise, the terms “connected,” “coupled,” and “mounted,” and variations thereof herein are used broadly and encompass direct and indirect connections, couplings, and mountings. In addition, the terms “connected” and “coupled” and variations thereof are not restricted to physical, mechanical or other connections or couplings. The terms upper, lower, and vertical are intended for operative context only and are not necessarily intended to limit the invention only to those configurations or orientations. Furthermore, and as described in subsequent paragraphs, the specific mechanical and/or other configurations illustrated in the drawings are intended to exemplify embodiments of the invention. However, other alternative mechanical and/or other configurations are possible which are considered to be within the teachings of the instant disclosure.

5

An exemplary embodiment is shown in FIGS. 1 to 4, wherein there is provided a light fixture assembly 10 (FIG. 4) for supporting a light fixture 12 in a ceiling structure 14. The light fixture 12 is, in this case, a linear light fixture, while other exemplary embodiments may include non-linear light fixtures. The assembly 10 comprises a light fixture mounting structure generally shown at 16 in FIG. 4, having a pair of opposed boundary regions 18, 20 which are configured to fit within a designated light fixture receiving region 22 in the ceiling structure. A plurality of spring elements 24 are configured to be spaced outwardly from at least one of the boundary regions. In this case, the spring elements 24 are of a flat spring configuration with opposed planar surface regions 24*i*, 24*ii* as shown in FIG. 6, and are formed from a metal blank by one or more bending functions to the structure as shown more particularly in FIG. 7. Other exemplary embodiments may utilize spring elements of other configurations, such as by being formed integrally with a mounting structure or a portion thereof, to provide one or more of the functions and features as disclosed herein.

Referring to FIG. 5, each spring element 24 has a mounting region 26 configured to be anchored to the mounting structure 16 and a free end region 28 adjacent the opposed surface regions 24*i* and 24*ii* to extend therefrom and to be laterally outwardly biased in a first position, as shown in FIG. 5, to form a path of contact (for example a line of contact) C with a support surface 30 on the ceiling structure 14 to anchor the mounting structure 16 in the receiving region 22. Each of the spring elements 24 is configured to be movable (as represented by arrow R) toward the boundary region 20 in a second position, to release the path of contact "C", and thereby to release the mounting structure 16 and thus the light fixture 12, from the light fixture receiving region 22.

In the present exemplary embodiment, the light fixture mounting structure 16 is integrally formed with a light fixture body 32. In some exemplary embodiments, the light fixture mounting structure 16 may provide a mounting location for one or more light fixtures joined thereto, while providing the benefits of the mode by which the mounting structure 16 may be installed in the light fixture receiving region 22. The light fixture body 32, in this case, is formed, at least in part, from an extrusion process, though other manufacturing processes may also be utilized as desired.

Referring to FIG. 5, the boundary region 18 presents at least one support surface 36 on an outwardly extending flange 37 to engage a corresponding support surface 38 on the ceiling structure 14 adjacent the light fixture receiving region 22, while the spring elements 24 are positioned along the second boundary region 20. The first and second boundary regions 18, 20 each provide a respective surface 34, 40 (as viewed in FIGS. 5 and 6), to be positioned adjacent corresponding upright surfaces 42, 44 on the ceiling structure 14 and to face the light fixture receiving region 22. Thus, in some exemplary embodiments, the spring elements 24 are mounted only along the boundary region 20 though, in other exemplary embodiments, the spring elements 24 may also be provided along the boundary region 18 in place of the support surface 36. In the present exemplary embodiment, the spring elements 24 are configured to lock the mounting structure 16 in position in the light fixture receiving region 22 as a second step, following a first step of placing the boundary region 18 in an initial position with the associated support surface 36 in contact with the support surface 38, as shown in FIGS. 3 and 4.

6

Referring to FIG. 5, the boundary region 20 may include a recess 46 to receive an anchor fastener 48, for anchoring a corresponding spring element 24. Each spring element 24 may thus be provided with an opening 24*a* (as seen in FIG. 7) to receive the anchor fastener 48, though other configurations may also be utilized to anchor the spring element 24 and, for example, by the anchor fastener 48, such as by the use of intermediate clamping elements between the anchor fastener 48 and the spring element 24 which may be integral to the anchor fastener 48 or the spring element 24. The spring element 24 may also be provided with a bend line or region 50 (as shown in FIG. 7), in the present exemplary embodiment adjacent the opening 24*a*, to delineate the mounting and free end regions 26, 28, though the spring element 24 may alternatively provide a gradual transition between the mounting region 26 and the free end region 28.

Referring to FIGS. 8 and 9, the body 32 may be formed from a number of segments, in this case two as shown at 32*a* and 32*b*, to form the linear light fixture assembly 10. The body 32 may be further configured to provide an opening 52 to access light fixture components 54 therein, along with a cover 56 to close the opening 52. In this case, the light fixture components may be mounted in the body 32, or on the inside surface of the cover 56, or both. Referring to FIGS. 7, 12 and 13, each spring element 24 may further comprise a hinge region 60 adjacent the mounting region 26 and opposite the free end region 28, so that the cover 56 may be configured to engage the hinge region 60 for movement of the cover 56 relative thereto. As shown in FIG. 12, the cover may include a number of hinge openings 56*a*, each to receive a corresponding hinge region 60. Further, as seen in FIG. 7, in some exemplary embodiments, the hinge region 60 may be configured, such as for example in a hook-shape in cross section, to provide that the cover 56 remains engaged therewith during its range of travel between its open and closed positions, as both represented in FIG. 8, for segments 32*a* and 32*b* respectively.

In some exemplary embodiments as shown in FIGS. 5, 6, 10 and 11, the assembly 10 may provide one or more suspension structures 62 to suspend the body 32 when in a servicing mode with the opening 52 laterally oriented below the ceiling structure 14 for servicing. In this case, the cover 56 may be configured to hinge relative to the mounting region 26 to an open position, for example with the cover 56 oriented below the body 32 when in the servicing mode, or otherwise configured to present the light fixture components for servicing.

The suspension structures 62 may be provided in the form of at least two cables 62, ropes, chains and/or linkages or the like, to be anchored or coupled between the boundary region 18 and a corresponding location adjacent the light fixture receiving region 22, such as on a structure above the surface 38 as shown by the fastener 64 in FIG. 6.

Thus, while in some exemplary embodiments as shown in FIG. 6, the suspension structures 62 may be fastened at their respective opposite ends with anchor fasteners 64, other exemplary embodiments may use other fastening modes. For instance, as shown in FIGS. 11*a* to 11*c*, such anchoring may be achieved by way of an anchoring structure shown at 70 which is positionable on the light fixture body 32, and configured to receive an end region 62*a* of the suspension structure 62. As will be described, a locking structure, shown at 72, is movable between a releasable position as shown in FIG. 11*b* to receive the end region of the suspension structure 62 and a lock position as shown in FIG. 11*c* to hold the suspension structure 62 in the anchoring structure 70.

In some embodiments, the suspension structure **62** may be provided in the form of a cable **62**, while the end region of the cable **62** may be configured with an enlarged cable end structure **74**. The anchoring structure **70** includes a yoke portion **76** to receive the enlarged cable end structure **74** (as shown in FIG. **11b**), along with a gap **78** to receive the cable **62**. The locating structure **72** may be provided as a tab **80** which is configured to rotate according to arrow R1 from its upright (gap-open) position (FIG. **11b**) to an inclined (gap-closed) position (FIG. **11c**) wherein it extends across the gap **78** in the locking position to hold the cable therein. In this case, the tab **80** may be formed together with the yoke portion **76** from a single blank of metal, along with a mounting portion **82** to receive fastener **84** to mount the anchoring structure on the light fixture body **32**.

In some exemplary embodiments, as shown in FIGS. **11d** and **11e**, the suspension structures **62** may be anchored to a corresponding location shown at **84**, adjacent to the light fixture receiving region **22**, which in this case is provided by a passage **86** in a corresponding ceiling structural unit **88**, for example at t-bar structural unit. The suspension structure **62**, in this case cable **62**, may be provided with an anchoring unit **90** with a lateral dimension W and a passage **90a** to receive the cable **62** therethrough and which is held thereon by way of cable end structure **92**, to fit through the diameter D of the passage **86**. The cable **62** is of sufficient length to enable the anchoring unit to be drawn through the passage **86**, in the orientation shown in FIG. **11d**, and then reoriented laterally to cross the passage, as shown in FIG. **11e**, thus to anchor the cable **62**.

Thus, in some exemplary embodiments, one or more light fixtures **12** may be mounted in a corresponding receiving region **22** by first attaching the suspension structures **62** such as described above and as shown, for example, in FIG. **6** or in FIGS. **11a** to **11c**, between each of the light fixtures **12** and the corresponding receiving region **22**, thereby to provide the light fixtures **12** in the servicing mode as shown in FIG. **10** for one such light fixture. Thus, with the opening **52** open to the side of the housing in the servicing mode and below the ceiling structure **14**, the installer may complete such tasks as installing and/or switching components and completing wiring attachments between neighbouring light fixtures in the servicing mode and/or to one or more power supplies, all the while maintaining the light fixtures in the servicing mode below the ceiling structure. If desired, the light fixtures **12** may also be joined together directly, in end to end fashion, or joined to intermediate connection structures, hubs and the like to form assembled light fixtures, for example by way of the coupling assembly described in co-pending U.S. application Ser. No. 15/603,070, filed May 23, 2017, entitled ROTATIONAL COUPLERS FOR LIGHT FIXTURES, the entire subject matter of which is incorporated herein by reference. Such coupling assembly enables the installer to use a drive tool in a horizontal direction (i.e. with the drive axis of the drive tool being horizontal) which, in some cases, may be particularly beneficial because the light fixtures are below the ceiling structure **14**. The servicing mode thus enables a number of such light fixtures to be joined together with the installer not needing access for a sight line above the light fixture, and further without requiring access for a sight line above the ceiling structure **14** itself, to make carry out the above described assembly steps as is usually required with conventional light fixtures.

In some exemplary embodiments, once the two or more light fixtures may thus be fully assembled and joined together, their covers may be closed. The so formed light fixture assembly thus may present a composite flange **37**

made up of the individual aligned flanges **37** of the two or more light fixtures, along with a number of spring elements **24** located along the assembled length of the assembly. Thus, to complete the installation, the installer may first locate the aligned flanges **37** on the support surface **38** as shown in FIGS. **3** and **4**, and progressively raise the second boundary region **40** upwardly to cause the spring elements **24** to make contact with and slide against upright surface **40** until they pass above first support surface **30** and return to the first position to form the line path of contact C with a support surface **30** to anchor the mounting structure in the receiving region.

The light fixture assembly may be provided in a kit of parts or in two or more subassemblies, including various combinations of the features described in the present disclosure. Other features, such as the spring element **24** and components associated therewith, may also be provided in one or more kits or subassemblies.

Referring to FIGS. **6** and **14**, a release tool may be deployed to displace the spring element **24** to its released position according to arrow R. Such tool may be a screw driver **66** as shown in FIG. **13**, or the like which is suitably dimensioned to be oriented through the gap between surfaces **40** and **44** and then configured to contact the spring **24**. A downward motion by the tool, as represented by arrow D1 in FIGS. **6** and **13**, thus causes the spring element **24** to displace according to arrow R. These steps may then be carried out for each of the spring elements **24** to progressively release the linear light fixture **12**, thus causing it to rotate from the position shown in FIG. **6** to the intermediate inclined position as shown in FIGS. **3** and **4**. Next, the linear light fixture **12** may then be transferred as shown by D2 in FIG. **4**, to disengage the surface **36** from the surface **38** to release the linear light fixture **12** from its operative mode in the light fixture receiving region **22** toward, for example, the servicing mode as shown in FIG. **10**. Thus, in some exemplary embodiments, the light mounting structure **16**, or the light fixture **10** when the former is integrated therewith, may be installed and removed from the light fixture receiving region **22** without requiring any special tools. In the case of screw driver **66** need not be aligned with any particular location on the spring element **24**, other than to be oriented to be displaced downwardly along D1 to cause to rotation R.

Thus, in some exemplary embodiments, the light fixture assembly **10** may be configured to provide a linear light fixture installation, wherein the ceiling structure **14** is provided with an elongate receiving region in the example of light fixture receiving region **22**. The linear light fixture **12** may thus be configured with an elongate body such as the light fixture body **32**, to define an elongate opening **52** to expose one or more light fixture components when in a servicing mode and accessible through the opening. An elongate cover, such as cover **56** may be hingedly engaged along a boundary of the elongate opening **52** to cover the opening **52**. In this case, the cover **56** may be configured to present an otherwise inner surface with one or more light fixture components positioned thereon. One or more support elements, such as the suspension structures **62**, may be configured to join a second boundary of the body **32** with the ceiling structure **14**. The light fixture may be further configured to be releasable from an operative mode when installed in the elongate receiving region of the ceiling structure **14** to a servicing mode, when suspended by the suspension structures **62** below the ceiling structure with the first boundary of the elongate opening **52** positioned above the second boundary of the elongate opening **52**, and with the cover **56** oriented below the second boundary of the

elongate opening to present the elongate opening **52** laterally to permit servicing of the light fixture **12** from a side thereof in the servicing mode.

Thus, in some exemplary embodiments, the cover **56** may present a surface on which one or more components may be installed and thus be presented in a serviceably accessible condition in the servicing mode. Thus, the light fixture body **32** and cover **56** may be configured to open in a manner similar to a clam shell, by providing two hinged or pivotally coupled halves or sections of the light fixture body and with each half including one of a pair of opposed surfaces defining boundaries of an interior and which, in the servicing mode, open to present both surfaces laterally (or in a horizontal direction) relative to the ceiling structure, when suspended therefrom in a manner to allow such opening to occur, by securing the suspension structures **62** adjacent a longitudinal boundary of one of the halves and distal to a hinge point between the hinged halves or sections.

While the present disclosure describes various exemplary embodiments, the disclosure is not so limited. To the contrary, the disclosure is intended to cover various modifications and equivalent arrangements, as will be readily appreciated by the person of ordinary skill in the art.

The invention claimed is:

1. A light fixture assembly for supporting a light fixture in a ceiling structure, comprising a light fixture mounting structure having a pair of opposed boundary regions configured to fit within a designated light fixture receiving region in the ceiling structure, and a plurality of flat spring elements configured to be spaced outwardly from at least one of the boundary regions, each flat spring element having parallel opposed surface regions and a mounting region configured to be anchored to the mounting structure and a free end region adjacent the parallel opposed surface regions to extend therefrom and to be laterally outwardly biased in a first position away from the corresponding boundary region, each flat spring element includes an opening to receive an anchor fastener, and a bend region adjacent the opening to delineate the mounting and free end regions, each of the flat spring elements configured to be movable from the first position toward the corresponding boundary region in a second position as the flat spring elements make contact with and slide against an upright surface of the designated light fixture receiving region until the flat spring elements pass above a support surface region on the ceiling structure and return to the first position to form a path of contact with the support surface region to anchor the mounting structure in the receiving region, each of the flat spring elements configured to be movable from the first position toward the corresponding boundary region in a second position to release the path of contact to release the mounting structure from the receiving region; and wherein the light fixture body defines an opening, and further comprises a cover to close the opening, each flat spring element further comprising a hinge region adjacent the mounting region and opposite the free end region, and wherein the cover is configured to engage the hinge region for movement of the cover relative thereto.

2. An assembly as defined in claim **1**, wherein the cover includes a number of hinge openings, each to receive the hinge region of a corresponding flat spring element.

3. An assembly as defined in claim **2**, wherein the hinge region is hook shaped in cross section.

4. A light fixture assembly for supporting a light fixture in a ceiling structure, comprising: a light fixture mounting structure having a pair of opposed boundary regions con-

figured to fit within a designated light fixture receiving region in the ceiling structure, and a plurality of flat spring elements configured to be spaced outwardly from at least one of the boundary regions, each flat spring element having parallel opposed surface regions, a mounting region, and a free end region; each flat spring element includes an opening to receive an anchor fastener, and a bend region adjacent the opening to delineate the mounting and free end regions; each flat spring element is anchored to the mounting structure and the free end region adjacent the parallel opposed surface regions to extend therefrom and to be laterally outwardly biased in a first position away from the corresponding boundary region, each of the flat spring elements configured to be movable from the first position toward the corresponding boundary region in a second position as the flat spring elements make contact with and slide against an upright surface of the designated light fixture receiving region until the flat spring elements pass above a support surface region on the ceiling structure and return to the first position to form a path of contact with the support surface region to anchor the mounting structure in the receiving region, each of the flat spring elements configured to be movable from the first position toward the corresponding boundary region in a second position to release the path of contact to release the mounting structure from the receiving region; the light fixture body defines an opening, a cover to close the opening, each flat spring element including a hinge region adjacent the mounting region and opposite the free end region, with the cover configured to engage the hinge region for movement of the cover relative thereto; and one or more suspension structures to suspend the light fixture body when in a servicing mode with the opening laterally oriented below the ceiling structure for servicing.

5. An assembly as defined in claim **4**, wherein the cover is configured to pivot relative to the hinge region toward an open position in which the cover is oriented below the light fixture body when in the servicing mode.

6. An assembly as defined in claim **4**, wherein the suspension structures comprise at least one of a pair of cables, ropes, chains and linkages, each of which is configured to be anchored between a boundary region and a corresponding location adjacent the light fixture receiving region.

7. An assembly as defined in claim **4**, further comprising an anchoring structure positionable on the light fixture body and configured to receive an end region of the suspension structure, and a locking structure movable from a releasable position to receive a designated mounting location on the suspension structure and a lock position to hold the suspension structure in the anchoring structure.

8. An assembly as defined in claim **7**, wherein the anchoring structure includes a designated anchoring location to engage the designated mounting location and a locking structure movable between releaseable and locked positions to control access to one of said designated mounting and locking locations.

9. An assembly as defined in claim **7**, wherein the suspension structure includes a cable, the designated mounting location being provided by an enlarged cable end structure.

10. An assembly as defined in claim **9**, wherein the anchoring structure includes a yoke portion to receive the enlarged cable end structure, the yoke portion further comprising a gap to receive the cable, the locating structure further comprising a tab configured to extend across the gap in the locking position to hold the cable in the gap.