



US010989788B2

(12) **United States Patent**  
**Lo Monte et al.**

(10) **Patent No.:** **US 10,989,788 B2**  
(45) **Date of Patent:** **Apr. 27, 2021**

(54) **RADIO FREQUENCY IDENTIFICATION (RFID) SYSTEM FOR DETERMINING LOCATION**

(71) Applicant: **Lion Group, Inc.**, Dayton, OH (US)

(72) Inventors: **Lorenzo Lo Monte**, Huntington, NY (US); **Daniel Labarowski**, Mason, OH (US); **Daniel Wetzel**, Kettering, OH (US); **Steven C. Schafer**, Beavercreek, OH (US); **Michael C. Wicks**, Utica, NY (US); **Andrew E. Bogle**, Beavercreek, OH (US); **Daryl M. Osterloh**, Dayton, OH (US); **Devin Smarra**, Beavercreek, OH (US); **Devin Spatz**, Beavercreek, OH (US)

(73) Assignee: **Lion Group, Inc.**, Dayton, OH (US)

(\* ) Notice: Subject to any disclaimer, the term of this patent is extended or adjusted under 35 U.S.C. 154(b) by 441 days.

(21) Appl. No.: **15/816,808**

(22) Filed: **Nov. 17, 2017**

(65) **Prior Publication Data**

US 2018/0136309 A1 May 17, 2018

**Related U.S. Application Data**

(60) Provisional application No. 62/423,528, filed on Nov. 17, 2016.

(51) **Int. Cl.**  
**G01S 5/06** (2006.01)  
**G01S 13/00** (2006.01)  
(Continued)

(52) **U.S. Cl.**  
CPC ..... **G01S 5/06** (2013.01); **G01S 5/0231** (2013.01); **G01S 5/12** (2013.01); **G01S 13/003** (2013.01);  
(Continued)

(58) **Field of Classification Search**  
CPC . G01S 5/0231; G01S 5/06; G01S 5/12; G01S 7/023; G01S 13/003; G01S 13/42;  
(Continued)

(56) **References Cited**

U.S. PATENT DOCUMENTS

3,701,150 A 10/1972 Dame  
4,307,397 A 12/1981 Holscher  
(Continued)

FOREIGN PATENT DOCUMENTS

CN 103550892 A 2/2014  
GB 2238210 A \* 5/1991 ..... G01S 13/755  
(Continued)

OTHER PUBLICATIONS

Definition for UHF, Wiley Dictionary of communications Technology: Terms, Definitions and Abbreviations (3rd ed.). Credo Reference: <https://search.credoreference.com/content/entry/wileycommtech/uhf/0> (Year: 1998).\*

(Continued)

*Primary Examiner* — Bernarr E Gregory

*Assistant Examiner* — Fred H Mull

(74) *Attorney, Agent, or Firm* — Mintz Levin Cohn Ferris Glovsky and Popeo, P.C.

(57) **ABSTRACT**

A system and bent-pipe transponder component for determining a location of an individual or object in three dimensional space. The system includes a transmitter configured to transmit a first wireless electromagnetic signal at a first frequency and at least one transponder that is configured to responsively emit a second wireless electromagnetic signal having a second frequency that is frequency-shifted from the first frequency. An included receiver detecting the first and second wireless electromagnetic signals is configured to provide an output of location information for the at least one transponder. A bent-pipe transponder component may

(Continued)

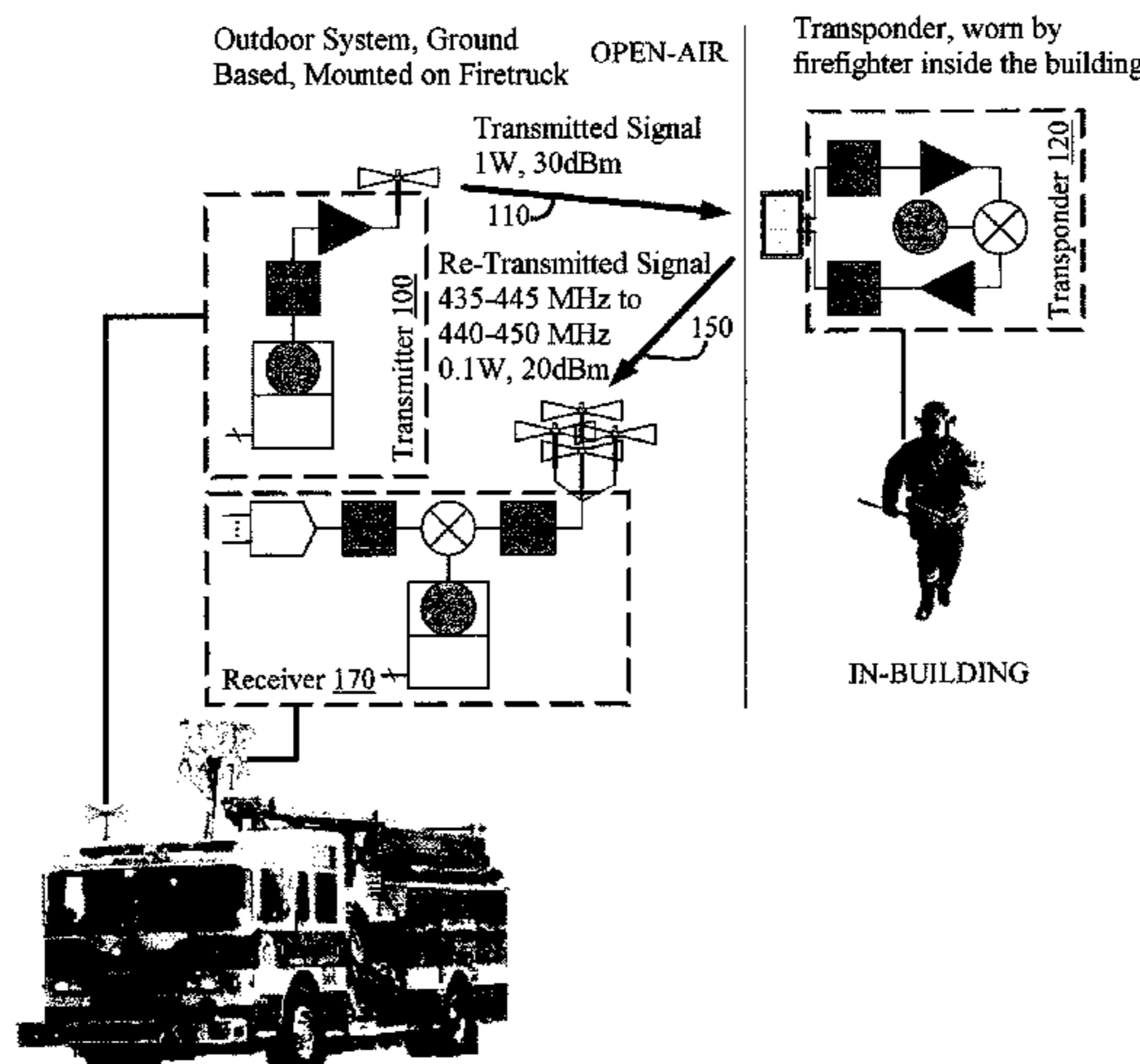

include a receiving antenna, an emitting antenna, and a frequency shift stage comprising an oscillator and a first mixer, with the frequency stage mixing a received first wireless electromagnetic signal with the output of the oscillator via the first mixer to produce the emitted second wireless electromagnetic signal.

**14 Claims, 11 Drawing Sheets**

(51) **Int. Cl.**

**G01S 13/82** (2006.01)  
**G01S 13/42** (2006.01)  
**G01S 5/12** (2006.01)  
**G01S 13/88** (2006.01)  
**G01S 13/76** (2006.01)  
**G01S 5/02** (2010.01)  
**G01S 7/02** (2006.01)  
**G01S 13/02** (2006.01)

(52) **U.S. Cl.**

CPC ..... **G01S 13/42** (2013.01); **G01S 13/76**  
 (2013.01); **G01S 13/82** (2013.01); **G01S**  
**13/888** (2013.01); **G01S 7/023** (2013.01);  
**G01S 2013/0245** (2013.01)

(58) **Field of Classification Search**

CPC ..... G01S 13/753; G01S 13/76; G01S 13/767;  
 G01S 13/82; G01S 13/878; G01S 13/888;  
 G01S 2013/0245; G01S 13/758; G01S  
 13/784; G01S 13/825; G06K 2017/0045  
 USPC ..... 342/44, 133  
 See application file for complete search history.

(56) **References Cited**

**U.S. PATENT DOCUMENTS**

4,804,961 A 2/1989 Hane  
 5,014,061 A \* 5/1991 Ghose ..... G01S 13/784  
 342/100  
 5,613,197 A 3/1997 Copeland et al.  
 5,955,991 A \* 9/1999 Kawakubo ..... G01S 13/345  
 342/108  
 6,150,921 A 11/2000 Werb et al.  
 6,351,215 B2 \* 2/2002 Rodgers ..... G01S 13/753  
 340/572.1  
 6,614,239 B2 9/2003 Borghi  
 6,965,344 B1 11/2005 Halsey et al.  
 7,109,844 B2 9/2006 Taki et al.  
 7,242,259 B2 7/2007 Heide et al.  
 7,242,303 B2 7/2007 Patel et al.  
 7,424,271 B2 9/2008 Shih et al.  
 7,511,604 B2 3/2009 Raphaeli  
 7,605,696 B2 10/2009 Quatro  
 7,633,387 B2 12/2009 Carmichael et al.  
 7,737,850 B2 6/2010 Malik  
 7,855,639 B2 12/2010 Patel et al.  
 7,868,760 B2 1/2011 Smith et al.  
 8,138,919 B2 3/2012 Christopher  
 8,188,908 B2 5/2012 Landt  
 8,334,808 B2 12/2012 Remez et al.  
 8,599,011 B2 12/2013 Schantz et al.  
 8,981,927 B2 3/2015 McSheffrey  
 9,014,635 B2 4/2015 Sadr  
 9,291,699 B2 3/2016 Sadr et al.  
 9,367,785 B2 6/2016 Sabesan et al.  
 9,699,621 B1 7/2017 Jarrett  
 10,129,704 B1 11/2018 Huseth et al.  
 2003/0007473 A1 1/2003 Strong et al.  
 2005/0102026 A1 \* 5/2005 Turner ..... A61B 5/0031  
 623/2.1

2005/0237953 A1 10/2005 Carrender et al.  
 2005/0270158 A1 12/2005 Corbett, Jr.  
 2006/0044179 A1 \* 3/2006 Fossum ..... G01S 13/82  
 342/46  
 2006/0187051 A1 \* 8/2006 Wu ..... G08B 13/2471  
 340/572.7  
 2006/0250271 A1 11/2006 Zimmerman  
 2007/0103273 A1 \* 5/2007 Feller ..... G01S 13/758  
 340/10.2  
 2008/0068267 A1 3/2008 Huseth et al.  
 2008/0122696 A1 5/2008 Huseth et al.  
 2009/0033500 A1 2/2009 Malik et al.  
 2010/0109844 A1 5/2010 Carrick et al.  
 2010/0271179 A1 10/2010 Maltseff  
 2010/0277338 A1 11/2010 Laroche  
 2011/0187600 A1 8/2011 Landt  
 2012/0280862 A1 11/2012 Moffatt et al.  
 2013/0194100 A1 8/2013 Granhed et al.  
 2015/0108210 A1 4/2015 Zhou  
 2015/0194030 A1 \* 7/2015 Davidson ..... G08B 13/248  
 340/572.7  
 2015/0373494 A1 \* 12/2015 Van Rijn ..... G01S 5/06  
 455/456.1  
 2017/0195834 A1 \* 7/2017 Na ..... G01S 5/12

**FOREIGN PATENT DOCUMENTS**

WO 2016/164031 4/2015  
 WO WO 2018094229 5/2018

**OTHER PUBLICATIONS**

Definition for badge, The American Heritage Dictionary of the English Language (6th ed.). Houghton Mifflin. Credo Reference: <https://search.credoreference.com/content/entry/hmdictenglang/badge/0> (Year: 2016).\*

Amendment to 47 CFR 15.247, Federal Register vol. 85, No. 63/Wednesday, p. 18149, Apr. 1, 2020 (Year: 2020).\*

47 CFR 15.247, <https://www.ecfr.gov>, Nov. 6, 2020 (Year: 2020).\*

Web page of Crowdrise featuring “TaskForceTracker: A New Way to Help First Responders,” <https://www.crowdrise.com/taskforcetracker-a-new-way-to-help-first-responders/>, 2 pages, first publication at least as early as Sep. 7, 2016.

Web page featuring “ResponderX Official—You Tube”, featuring two (2) on-line video presentations, entitled “TaskForceTracker from ResponderX” (Sep. 2016) and “Introducing TaskForceTracker”, <https://www.youtube.com/channel/UCF3qxwwO84bqGMSp2FHmMA>, Jul. 2016.

Web page featuring “TaskForceTracker from ResponderX—You Tube”, featuring on-line video presentation entitled “TaskForce Tracker from ResponderX” [https://www.youtube.com/watch?v=Vj54Ulk\\_Bss&feature=youtu.be&t=107](https://www.youtube.com/watch?v=Vj54Ulk_Bss&feature=youtu.be&t=107), 2 pages, Sep. 1, 2016.

ResponderX photograph of system with RF development board with AC4490 transceiver (by Laird), <https://www.facebook.com/responderx/photos/a.517904071700149.1073741828.480461448777745/517904045033485/?type=3&theater>, first publication at least as early as Sep. 1, 2015.

“Ramp-AC RF DVK Hardware User’s Guide Version 1.0”, by Laird, 10 pages, 2014.

Product literature entitled “The fastest way to wireless.” featuring AC4490 900MHz transceiver by AEROCOMM, 2 pages, <https://media.digikay.com/pdf/Data%20Sheets/Laird%20Technologies/AC4490.pdf>, first publication at least as early as Sep. 20, 2005.

ResponderX photograph of prototype system with AC4490LR transceiver (by AEROCOMM), 2 pages, <https://www.facebook.com/responderx/photos/a.525639017593321.1073741829.480461448777745/680590455431509/?type=3&theater>, first publication at least as early as Sep. 19, 2016.

ResponderX photographs of The Innovation Underground Grand Opening Party, 5 pages, <https://www.facebook.com/responderx/photos/a.535317486575474.1073741830.480461448777745/535817499908806/?type=3&theater>, Oct. 17, 2015.

(56)

**References Cited**

## OTHER PUBLICATIONS

ResponderX article entitled “Bryan (TX) Startup to Unveil New Firefighter Accountability Technology,” Fire Engineering, 2 pages, [http://www.fireengineering.com/articles/fe12017/04/responderx-firefighter-technology.html?cmpid=enl\\_fe\\_fireengineeringdaily2017-04-19&email\\_address=mkrolick@bullex.com&eid=293126198&bid=1729837](http://www.fireengineering.com/articles/fe12017/04/responderx-firefighter-technology.html?cmpid=enl_fe_fireengineeringdaily2017-04-19&email_address=mkrolick@bullex.com&eid=293126198&bid=1729837), Apr. 19, 2017.

ResponderX web page regarding TaskForceTracker, <https://responderx.com>, 9 pages, 2017.

“S&T’s POINTER System More Precisely Pinpoints First Responder Locations,” Science and Technology, 2 pages, <https://www.dhs.gov/science-and-technology/st-pointer-pinpoints-first-responder-locations>, Jan. 5, 2016.

New Technology Could Help Track Firefighters for Safety, Fire Apparatus & Emergency Equipment, 2 pages, [http://www.fireapparatusmagazine.com/articles/pt/2016/12/new-technology-could-help-track-firefighters-for-safety.html?cmpid=enl\\_FAEE\\_FireApparatusWeekly\\_2016-12-28&email\\_address=mwaterhouse@bullex.com&eid=293172460&bid=1621949](http://www.fireapparatusmagazine.com/articles/pt/2016/12/new-technology-could-help-track-firefighters-for-safety.html?cmpid=enl_FAEE_FireApparatusWeekly_2016-12-28&email_address=mwaterhouse@bullex.com&eid=293172460&bid=1621949), Dec. 19, 2016.

“Firefighter location technology: What’s available”, Fire Rescue news, 6 pages, <https://www.firerescue1.com/fire-products/communications/articles/2022412-Firefighter-location-technology-Whats-available/>, Dec. 14, 2014.

PCT, International Search Report and Written Opinion of the International Searching Authority, International Application No. PCT/US2017/062332, 12 pages, dated Feb. 16, 2018.

Psychoudakis, D. et al., “A Portable Low-Power Harmonic Radar System and Conformal Tag for Insect Tracking,” IEEE Antennas and Wireless Propagation Letters, vol. 7, pp. 444-447, 2008.

“GLANSER System Locates and Tracks Firefighters in Buildings,” Fire Apparatus & Emergency Equipment, 4 pages, Apr. 1, 2012.

“On Scene Firefighter Personnel Tracking Products,” 2 pages, 2016 <http://www.firecommand.org/on-scene-firefighter-personnel-tracking-products/>.

McKenna, C., RFID System Tracks Firefighters in Real Time, Improves Incident Management, featured on Government Technology, 2 pages, 2010 <http://www.govtech.com/featured/RFID-System-Tracks-Firefighters-in-Real.html>, Feb. 11, 2020.

“Lithium Battery Failures,” Electropaedia, Battery and Energy Technologies, 5 pages, first publication at least as early as 2011 [http://www.mpoweruk.com/lithium\\_failures.htm#breakdown](http://www.mpoweruk.com/lithium_failures.htm#breakdown).

“GPS Basics,” 9 pages, first publication at least as early as 2013 <https://learn.sparkfun.com/tutorials/gps-basics>.

“GLANSER: A Scalable Emergency Responder Locator System”, WPI Workshop, 21 pages, Aug. 1, 2011 [https://web.wpi.edu/Images/CMS/ECE/GLANSER-WPI\\_PPL\\_2011-AmitKulkarni-Aug1\(1\).pdf](https://web.wpi.edu/Images/CMS/ECE/GLANSER-WPI_PPL_2011-AmitKulkarni-Aug1(1).pdf).

Zack, K. et al., “Compact Spiral Antenna for Space Based Applications,” Antennas and Propagation Society International Symposium (APSURSI), IEEE 2014, pp. 1708-1709.

Stimson, G.W., Airborne Radar (2nd Edition), Raleigh, N.C., Sci-Tech Publishing Inc., pp. 6, 7, 91 and 100, 1998.

Galdorisi, G. et al., Leave No Man Behind, Hudson, WI, BMI Publishing, p. 391, 2009.

Lau, Z., “A No-Tune 2-Meter Bandpass Filter,” QST, pp. 54-55, May 2000.

Cho, C. et al., “Passive Wireless Frequency Doubling Antenna Sensor for Strain and Crack Sensing,” IEEE Sensors Journal, vol. 16, No. 14, pp. 5725-5733, Jul. 16, 2016.

Murata Manufacturing Co., product datasheet for SF2038B, 76.500 MHz SAW Filter, Mar. 27, 2014.

Lewis, M. “Surface Skimming Bulk Waves,” Ultrasonic Symposium Proceedings, pp. 744-752, 1977.

Moell, J., “Transmitter Hunting: Tracking Down the Fun—Part 1,” QST, pp. 48-51, Apr. 1993.

“Navigating Budget Cuts,” Taxpayers for Common Sense, 2 pages, Jan. 15, 2010 <http://www.taxpayer.net/budget-appropriations-tax/navigating-budget-cuts/>.

Chaniotakis et al., “Frequency Response: Resonance, Bandwidth, Q factor,” 11 pages, Spring 2006 [https://ocw.mit.edu/courses/electrical-engineering-and-computer-science/6-071-introduction-to-electronics-signals-and-measurement-spring-2006/lecture-notes/resonance\\_qfactr.pdf](https://ocw.mit.edu/courses/electrical-engineering-and-computer-science/6-071-introduction-to-electronics-signals-and-measurement-spring-2006/lecture-notes/resonance_qfactr.pdf).

DeMartino, C., “6 Types of Resonators Used Across the RF/Microwave Universe,” 11 pages, Sep. 9, 2015 <http://www.mwrf.com/components/6-types-resonators-used-across-rfmicrowave-universe>.

“Coplanar Waveguide,” 3 pages, first publication at least as early as 2014 <https://www.microwaves101.com/encyclopedias/327-coplanar-waveguide-microwave-encyclopedia-microwaves101-com>.

“S&T’s Pointer System More Precisely Pinpoints First Responder Locations,” Science and Technology, U.S. Department of Homeland Security, 2 pages (Jan. 5, 2016).

“Precision Outdoor and Indoor Navigation and Tracking for Emergency Responders (POINTER),” DHS Science and Technology Directorate, U.S. Department of Homeland Security, 1 page (Jan. 11, 2016).

EP, Search Report, European Application No, 17871214.7, 9 pages. (dated May 26, 2020).

\* cited by examiner

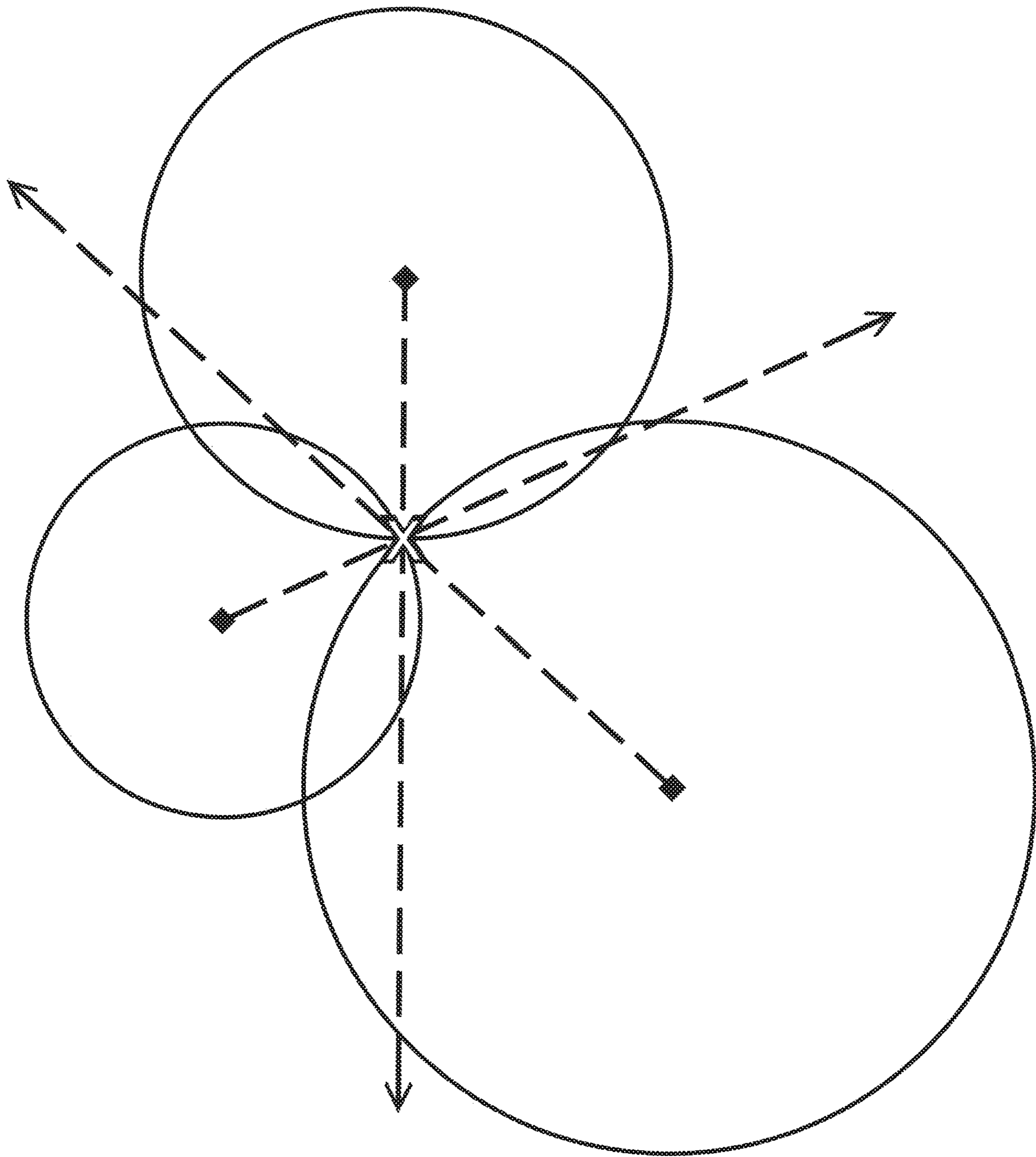

(prior art)

**Fig. 1**

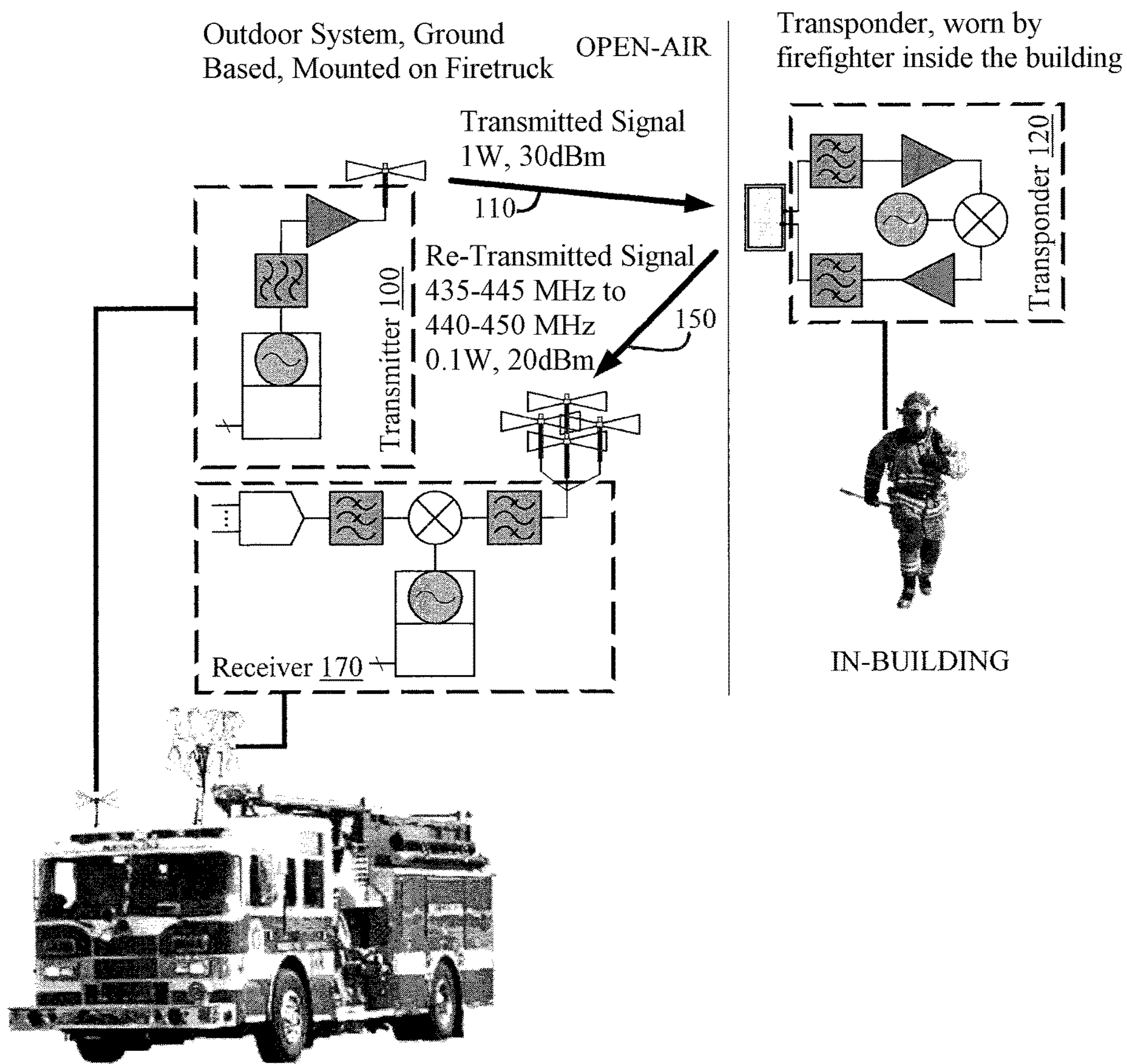
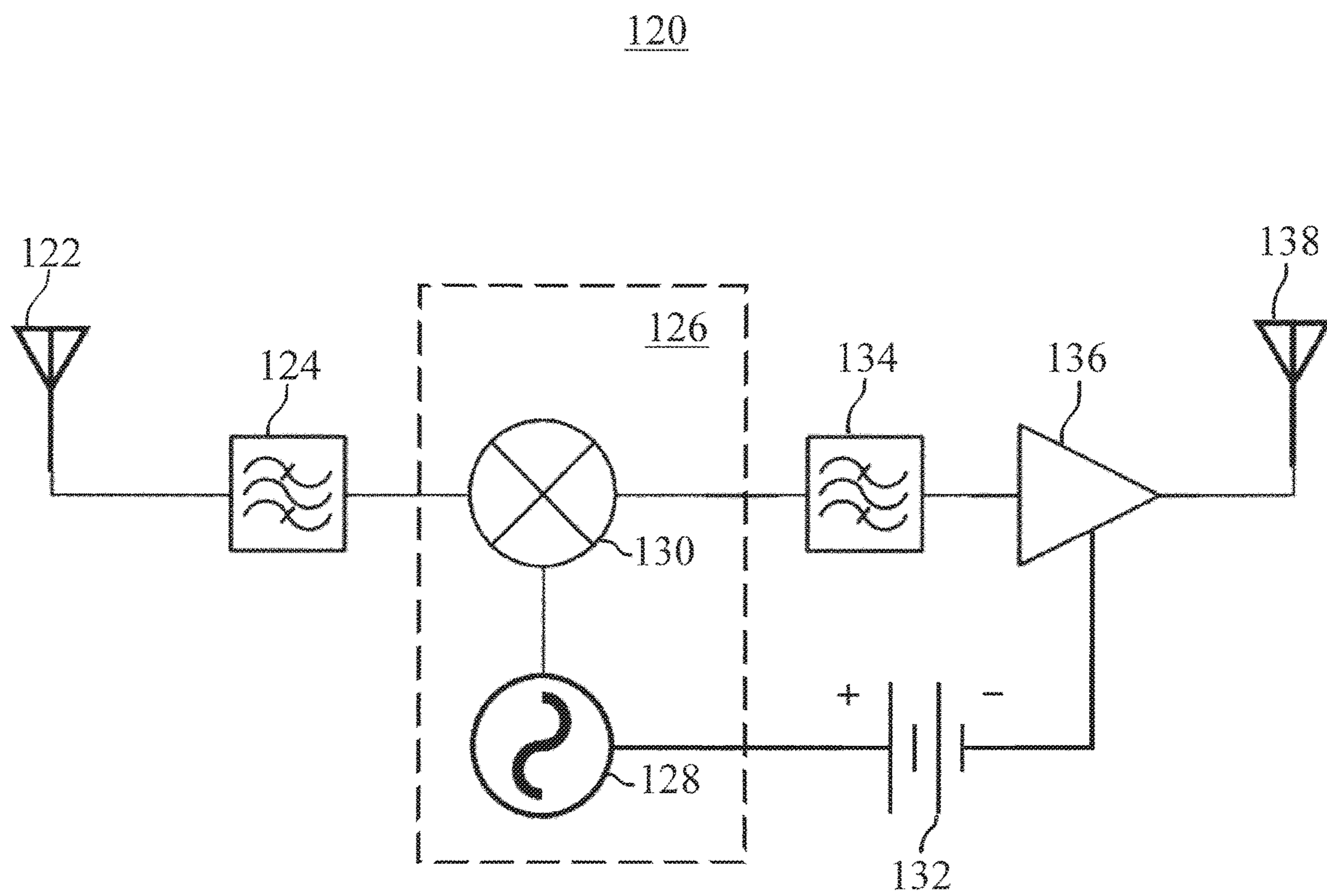

Fig. 2



**Fig. 3**

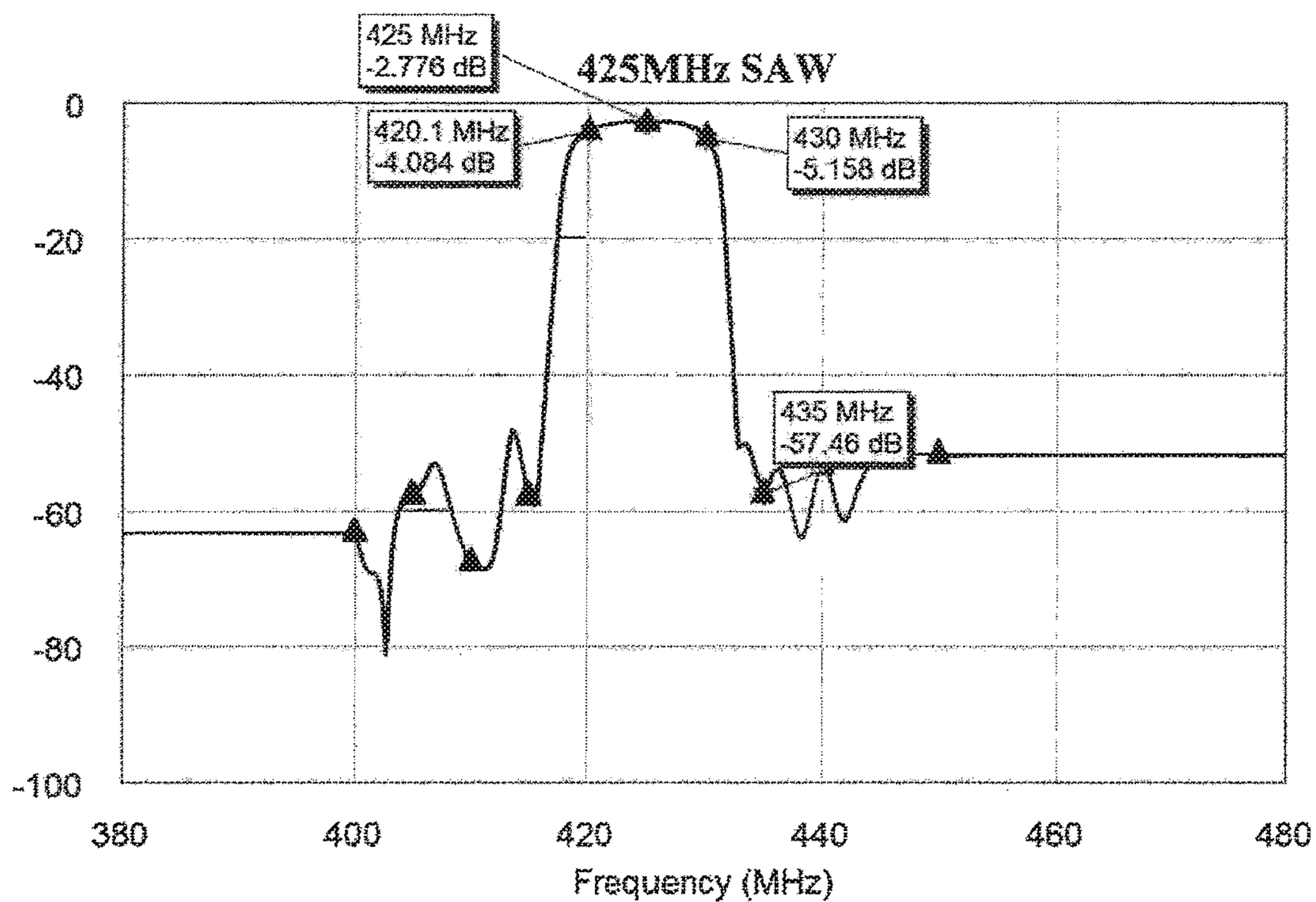

Fig. 4

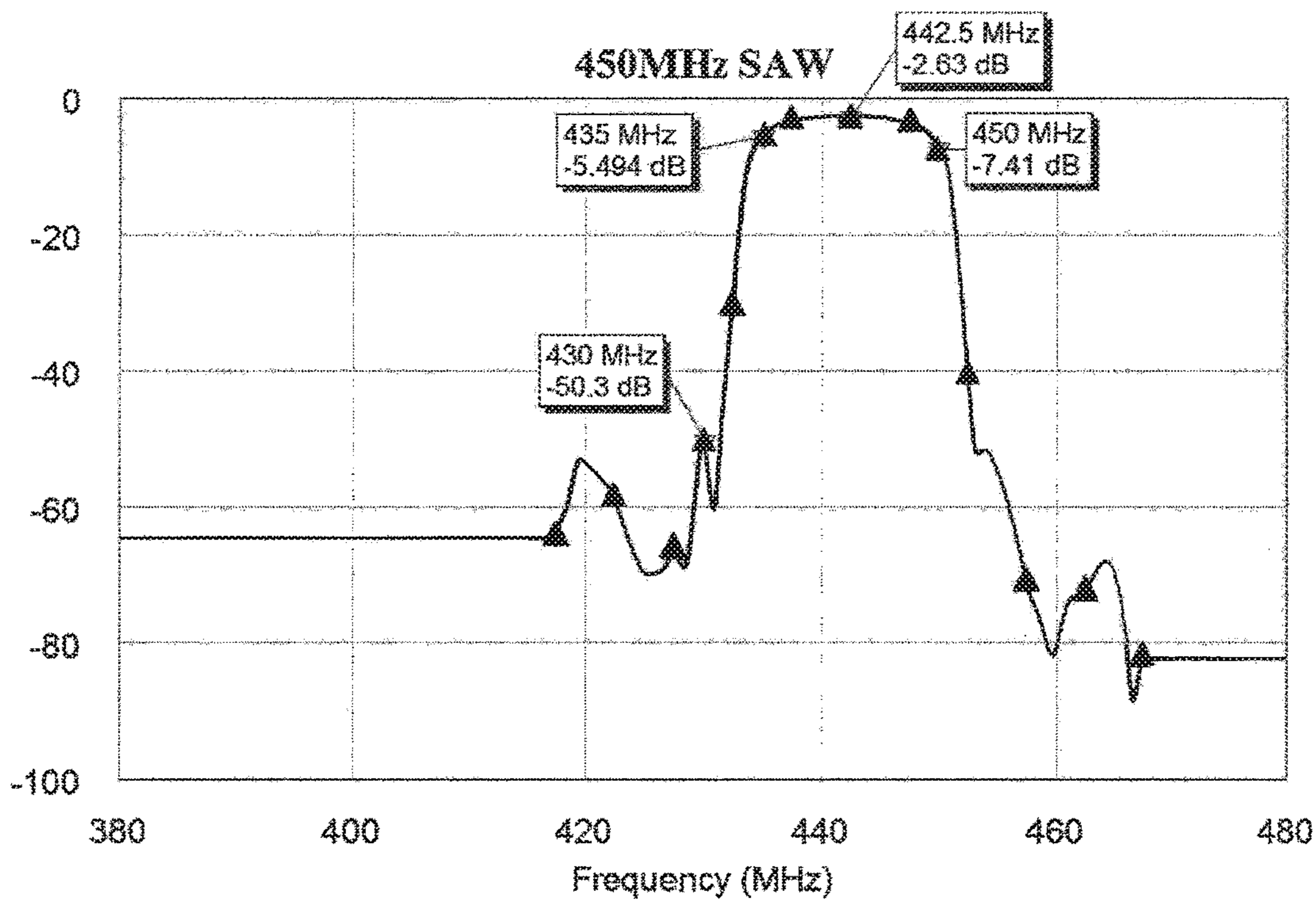

Fig. 5

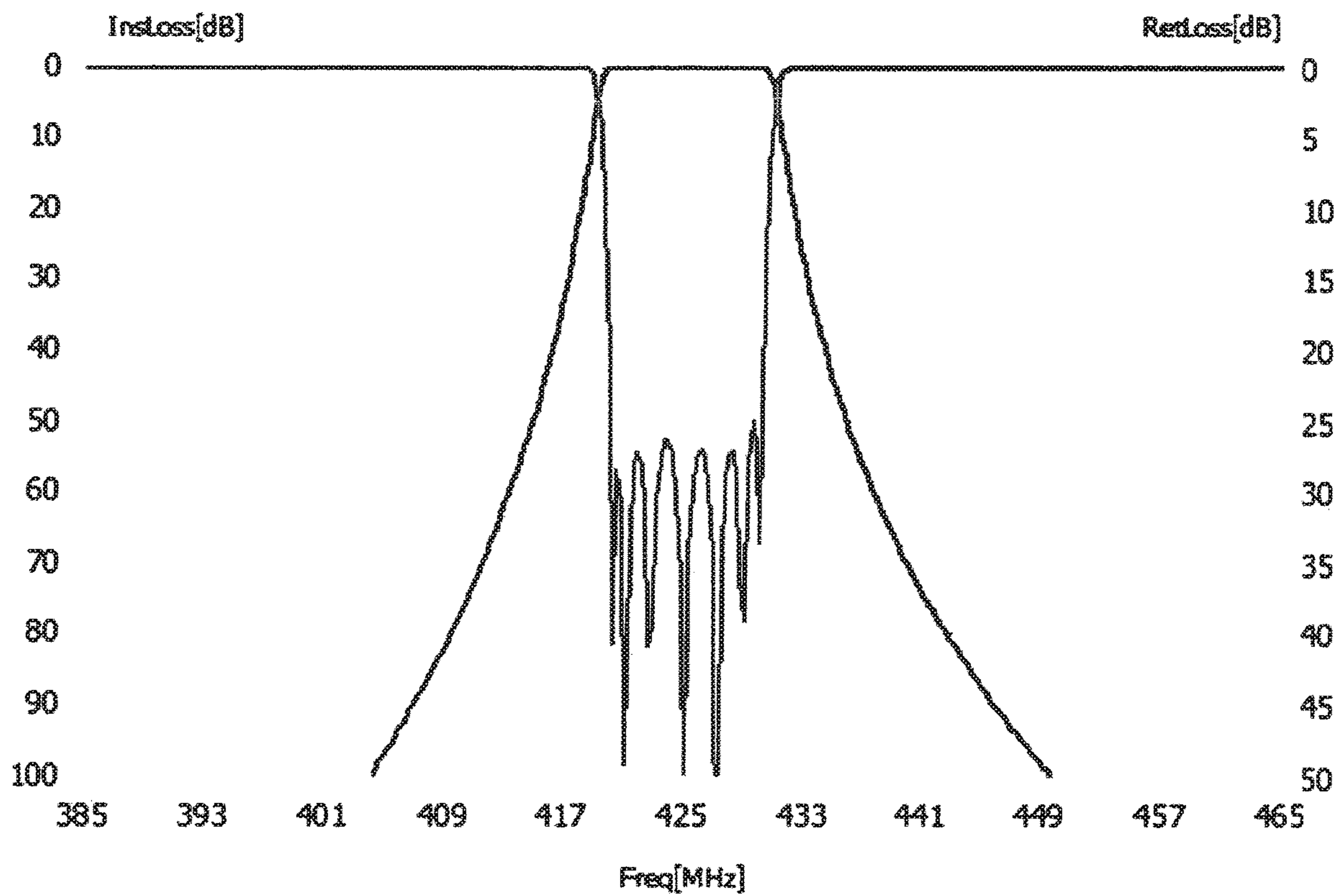

Fig. 6

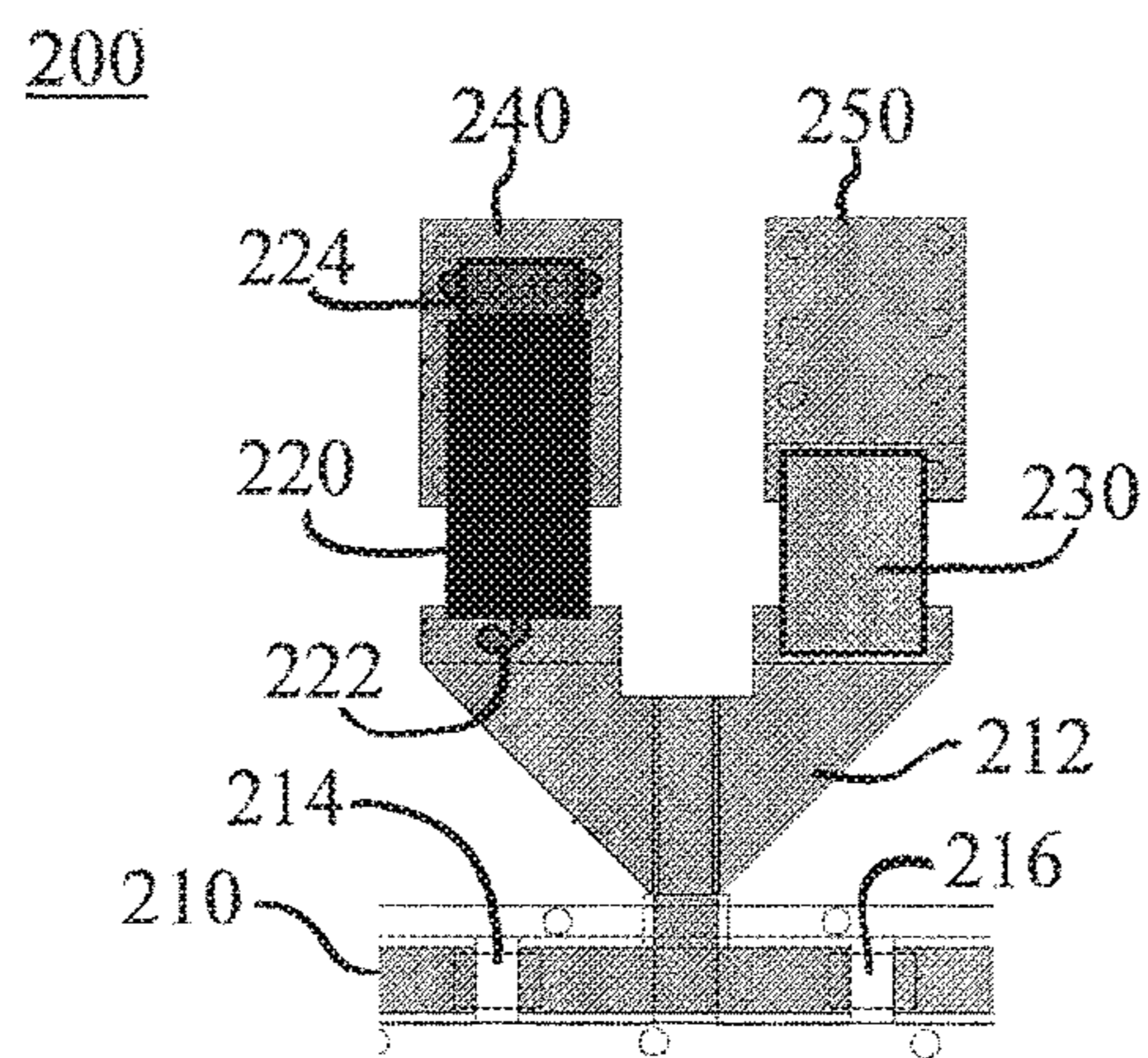

Fig. 7



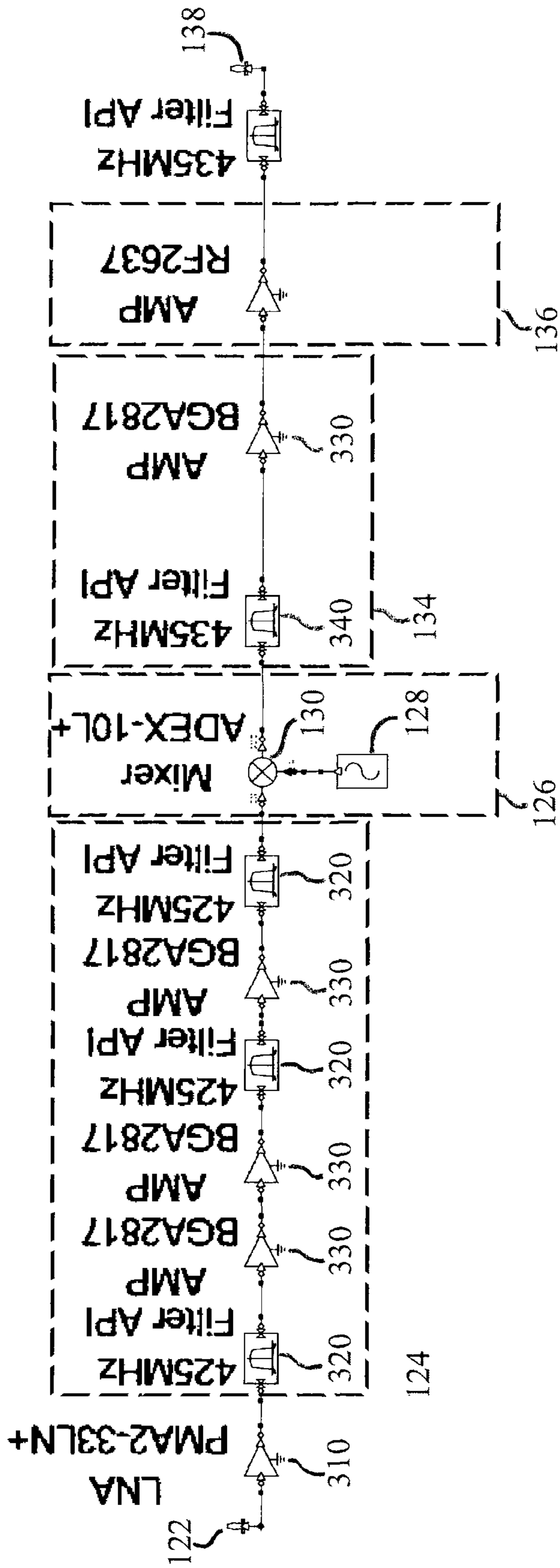
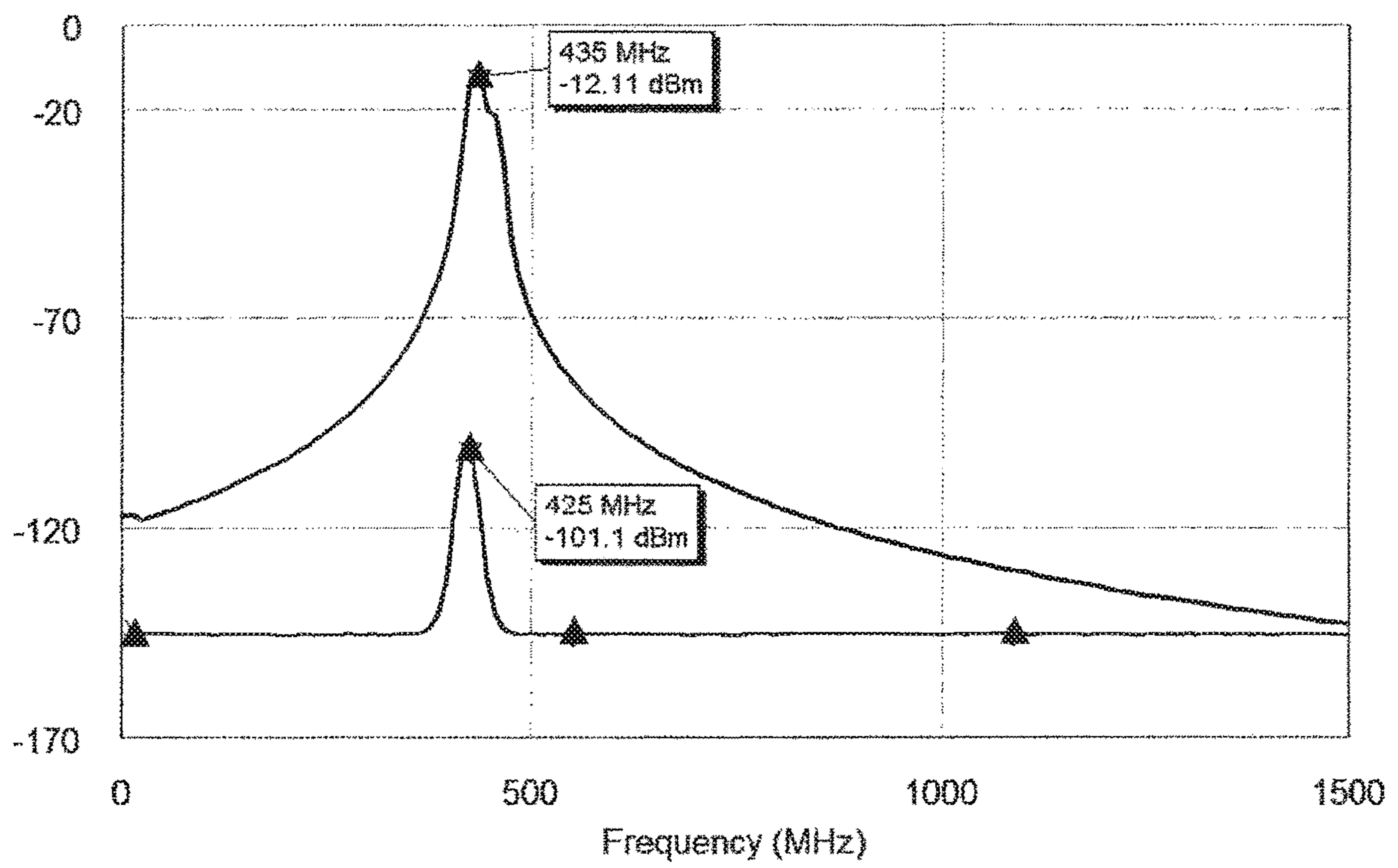

Fig. 8



**Fig. 9**

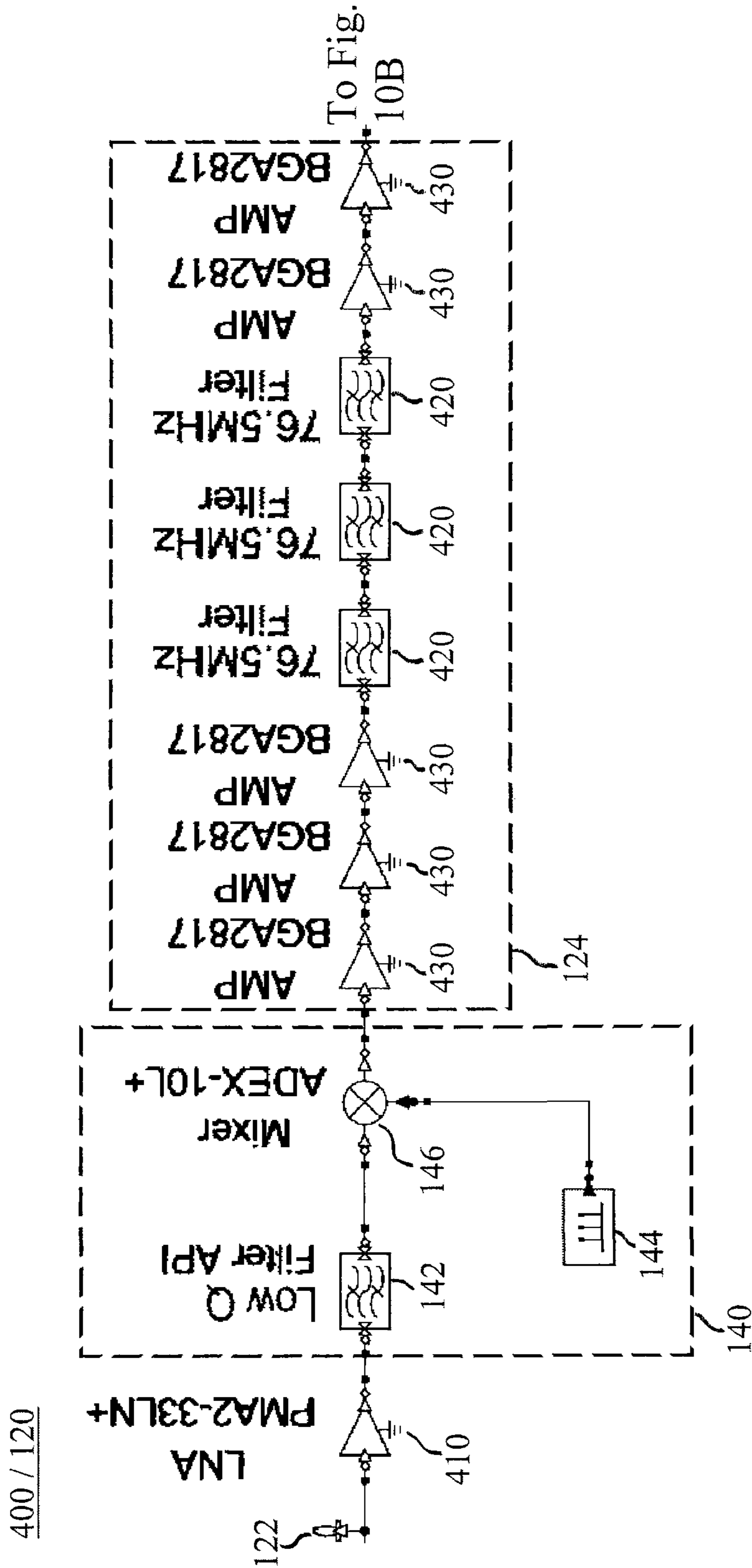

Fig. 10A

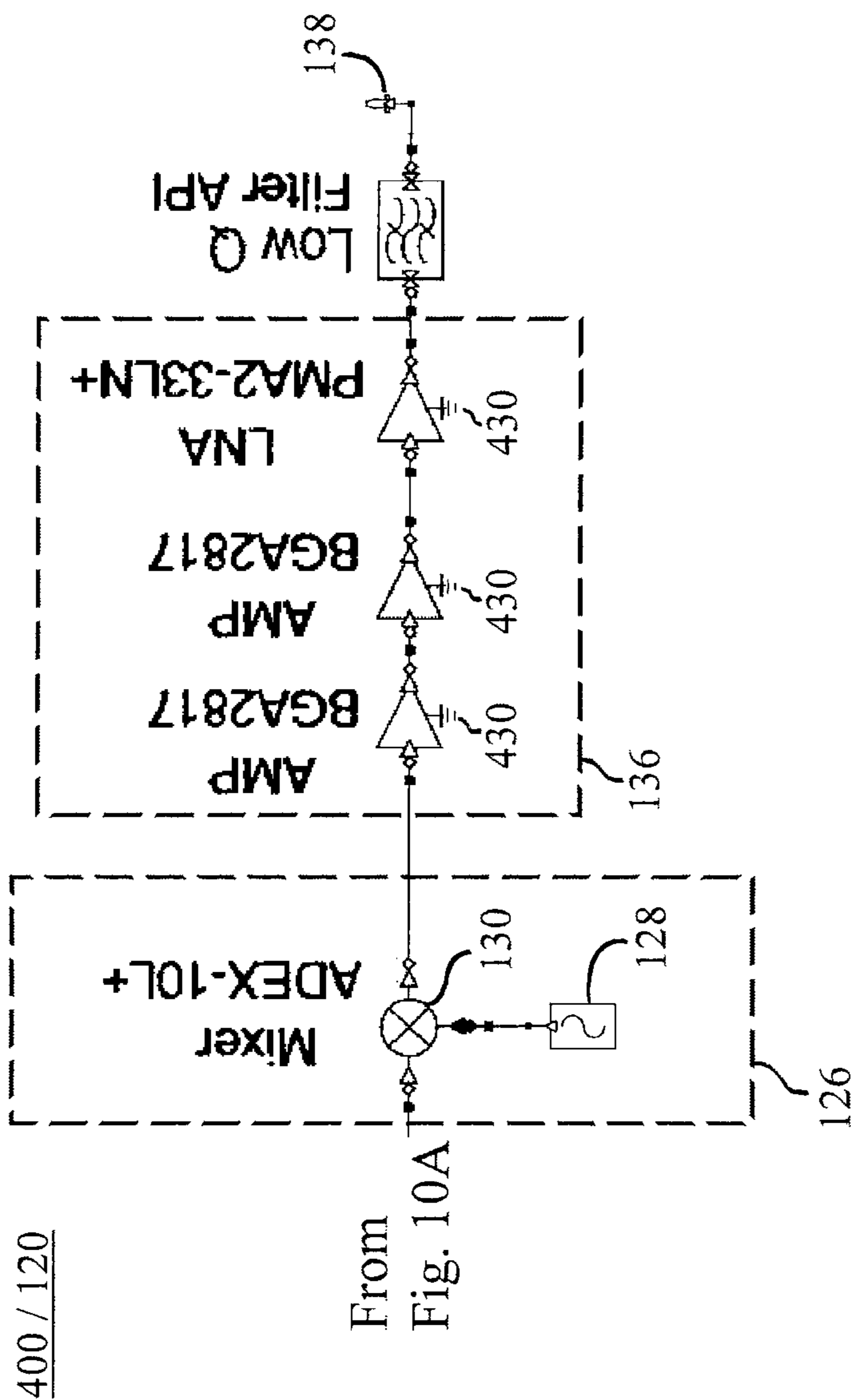
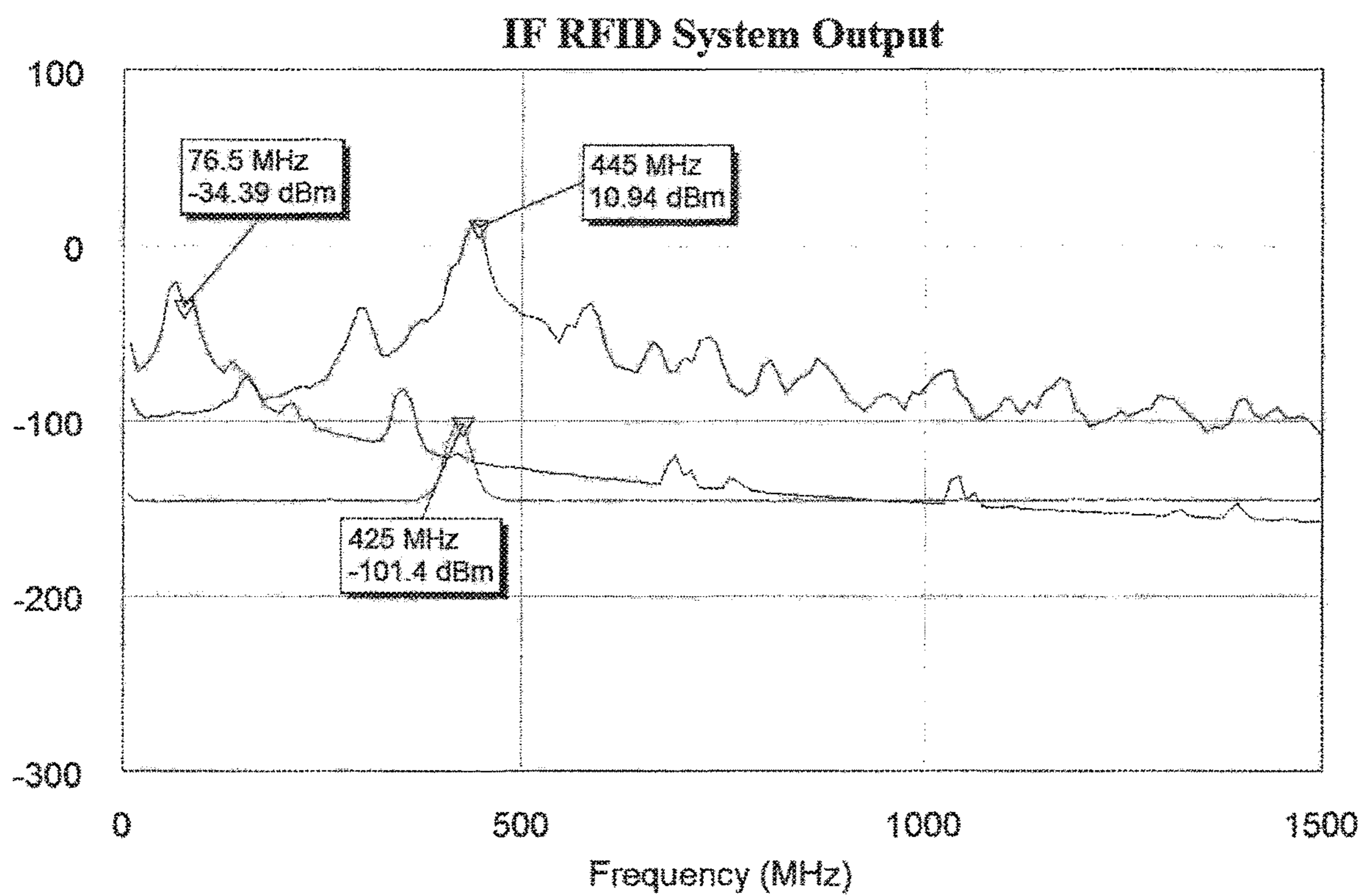

Fig. 10B



**Fig. 11**

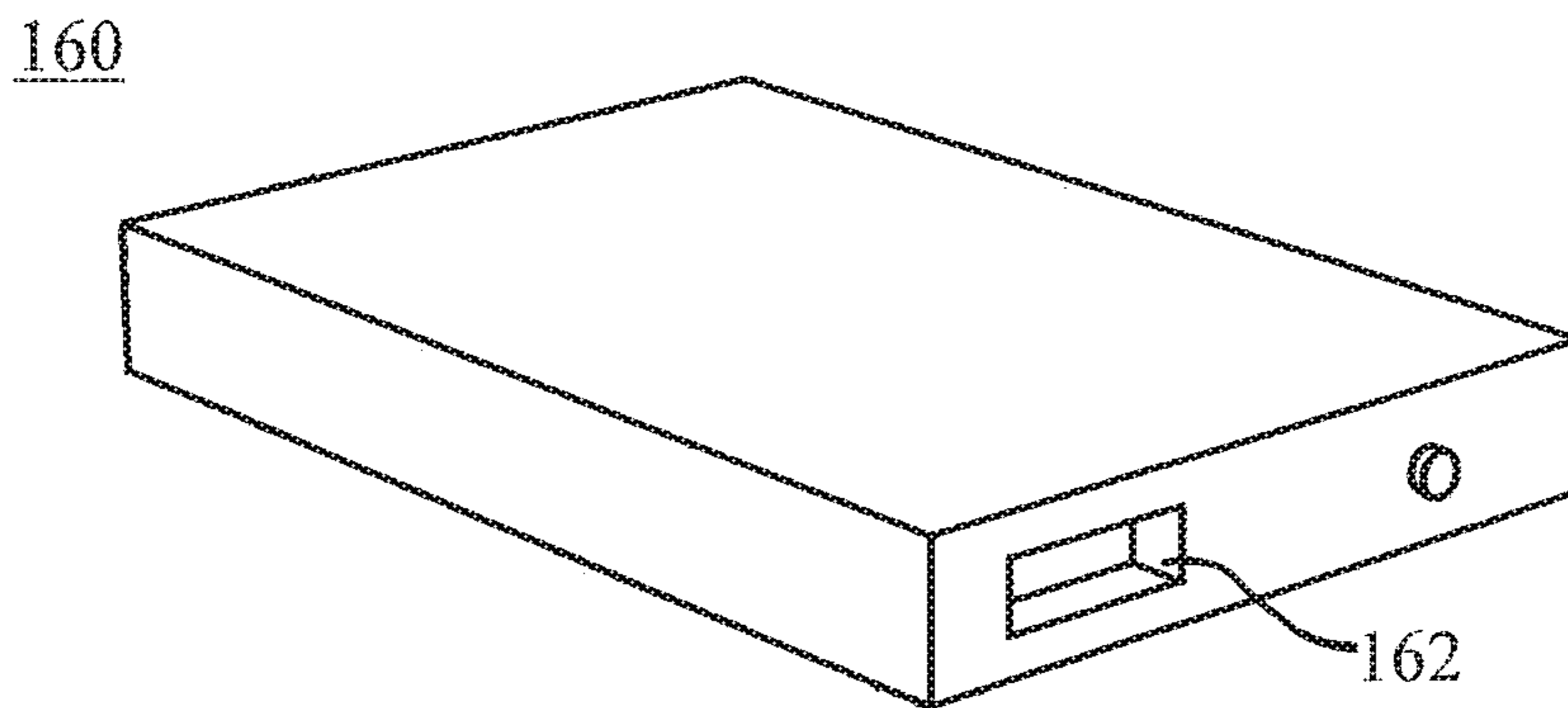

Fig. 12

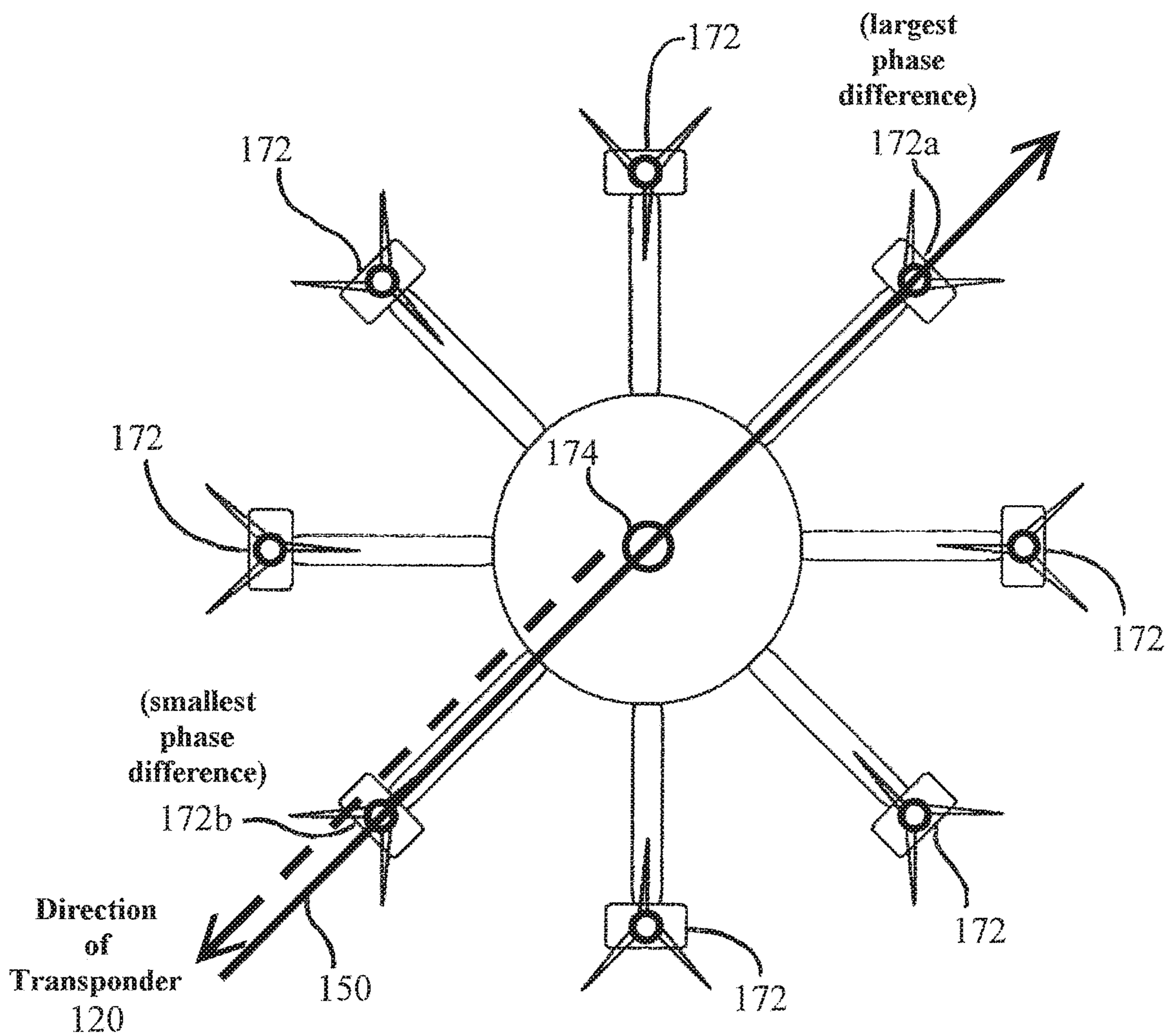

Fig. 13

## 1

**RADIO FREQUENCY IDENTIFICATION  
(RFID) SYSTEM FOR DETERMINING  
LOCATION**

BACKGROUND

Some fire departments may use accountability systems to identify which firefighters are on-site at an incident and, particularly, which are deployed within a building or structure. Such accountability systems track the status of firefighters as present and/or as having entered and exited a building; however, such systems are unable to provide geolocation within a building. In order to track firefighters within a building, additional technologies such as global positioning systems (GPS), Wi-Fi, and other wearable systems may be employed.

GPS systems are well-known and widely available. However, GPS signals rapidly deteriorate within a building, which weakens the ability of this approach to determine the location of an individual after entry. Alternately, wearable Wi-Fi emitters may be used to advertise the location of an individual. The reader will appreciate that Wi-Fi tracking systems typically use trilateration and/or triangulation to determine the location of an emitter, where trilateration uses received signal strength or time-of-flight to determine the distance to an emitter and triangulation uses angle of arrival to determine direction to an emitter, and that both methods can require placing a set of distributed receivers around a building at known or determined locations. However, it is often time consuming to distribute receivers around a building at previously determined locations and/or to determine the position of a newly selected location. Thus, this approach may not be practical during an urgent situation such as a fire.

Inertial systems using doubly integrated accelerometer data may track and report movement away from a starting point. However, the localization accuracy of an inertial tracking system decreases over time due to accumulated errors, even during periods when an individual remains stationary. Thus, this approach may not be practical since the starting location of each firefighter would have to be the same or otherwise known, and the reported location of each firefighter would become less and less accurate over time.

Finally, through-the-wall radar systems have been used to locate targets behind walls and inside buildings. However, these radar systems frequently lack the ability to discern a target, such as a firefighter or other first responder, from background objects and clutter, such as furniture, debris, lumber, or thick vegetation. This issue is further exacerbated at distances of about forty meters or more from the radar system transceiver, so that this approach may be unusable for large and/or densely stocked structures such as warehouses and factories, or even smaller structures for which there is limited access and/or a need to maintain a large standoff distance.

Accordingly, there is a need for a reliable, accurate, and economical system for determining the location of individuals within mixed environments that include buildings or other structures.

SUMMARY

A first embodiment is a system for tracking individuals in three dimensional space, and providing an output. The reader will appreciate that although a system for tracking firefighters or other first responders is described, the disclosure is not limited to this specific application. Indeed, the

## 2

disclosed systems and methods may be used in other embodiments for tracking objects, such as equipment, within three dimensional space. In still other embodiments, the system may be used for monitoring the location of a nominally fixed location, such as a wall or ceiling of a building, within three dimensional space.

The system can include a transmitter that transmits a first wireless electromagnetic signal, such as a pulsed signal, a frequency modulated continuous wave, and/or an orthogonal frequency division multiplexed signal, in the radio or microwave frequency range.

The system can also include a number of transponders that may be secured to individuals, (and/or, in other embodiments, objects other than people and nominally fixed locations). The reader will appreciate that although multiple transponders are described, “a number” may include only one transponder, and the plural “transponders” will be used to refer to one or more transponders throughout this application. The transponders are configured to receive the first wireless electromagnetic signal and to responsively emit a second wireless electromagnetic signal, such as the same pulsed signal or frequency modulated continuous wave, in the radio or microwave frequency range. Each transponder includes a frequency shift stage such that the second wireless electromagnetic signal is responsively emitted at a different frequency relative to that of the first wireless electromagnetic signal. In other embodiments, each transponder may be configured to emit the second wireless electromagnetic signal at a different frequency relative to that of the first wireless electromagnetic signal and the frequencies of the second wireless electromagnetic signals emitted by the other transponders.

The system can further include a receiver that detects and processes the second wireless electromagnetic signals emitted by the transponders. The receiver has an array of antenna elements distributed across a three dimensional volume of space. In some constructions, the receiver may be at the same location as, and physically coupled to, the transmitter. In other constructions, the receiver may be separated from, but operatively coupled to, the transmitter. The physical or operative coupling of the receiver and transmitter provides an input to the receiver for time-of-flight information concerning the first wireless electromagnetic signal, where such input is used with a respective second wireless electromagnetic signal to determine the distance to a respective transponder.

The receiver provides an output of location information for the number of transducers. The output may be a visual or representative output on a display screen that shows the location of individual responders relative to each other and/or a building and/or geographic indicators such as streets or geographic information system (GIS) data. For example, the receiver may include the display screen, with the output being the displayed visual or representative output. The output may alternately be data, including the location information, that is transmitted to a remote device. For example, the receiver may transmit location information to an application executing on a tablet device, a mobile phone, a desktop computer, a laptop computer, or the like that displays the visual or representative output.

By emitting a frequency-shifted response signal, each transponder can be easily identified by the receiver as being distinct from the emissions of the transmitter and back-scattered reflections of the first wireless electromagnetic signal. Each transponder may, in some constructions, be a solely analog transponder and lack any digital electronics, digital processing circuitry, digital signal processors, or the

like. Thus, each transponder may be considered a “dumb” transponder that does not attach or append any signals, stored data, or identification information to the emitted response signal, and instead merely repeats the transmitter’s signal as a frequency-shifted response signal.

#### BRIEF DESCRIPTION OF THE DRAWINGS

FIG. 1 graphically illustrates exemplary, trilateralization-based and triangulation-based methods for determining the location of an individual on a two dimensional plane.

FIG. 2 is a schematic illustration of an embodiment of the disclosed system.

FIG. 3 is a schematic illustration of an exemplary transponder.

FIG. 4 illustrates insertion loss and isolation for a receive-side Surface Acoustic Wave filter of an exemplary transponder of the system.

FIG. 5 illustrates insertion loss and isolation for an emitting-side Surface Acoustic Wave filter of an exemplary transponder of the system.

FIG. 6 illustrates isolation for a receive-side coaxial-cable-based resonant filter of another exemplary transponder of the system.

FIG. 7 illustrates a resonator unit of a receive-side coaxial-cable-based resonant filter of the exemplary transponder of FIG. 6.

FIG. 8 is a schematic diagram of a first working example of such a transponder.

FIG. 9 is a time-averaged power spectral density plot of received and emitted signals in the working example of FIG. 8.

FIGS. 10A and 10B are a schematic diagram of a second working example of such a transponder.

FIG. 11 is a time-averaged power spectral density plot of received and emitted signals in the working example of FIGS. 10A and 10B.

FIG. 12 is an exemplary housing and form factor for such a transponder.

FIG. 13 is an exemplary receiver antenna arrangement.

#### DETAILED DESCRIPTION

Stated simply, the goal of any tracking system is to find the location of one or more targets from one or more reference points. At a simple level, FIG. 1 illustrates a method of locating a target positioned at known distances from a set of observation points commonly known as trilateralization. The location of each observation point (X symbol) is known, while only the target’s distance from each observation point is known. With respect to each individual observation point, the target could be located anywhere on the respective circular boundaries shown in FIG. 1. Combining the information from at least three differently-located observation points adds additional constraints that limit the possible locations to a single location where all three circular boundaries intersect (marked by an X symbol). Trilateralization forms the basis of many terrestrial radio navigation systems. While it is difficult to illustrate, one can imagine a three dimensional system where, instead of being on respective circular boundaries, the target could be located anywhere on respective spherical boundaries centered on the respective observation points. Combining the information from at least four differently-located observation points limits the possible locations to a single location where all four spherical boundaries mutually intersect in three dimensional space. This approach forms the basis of systems like

the Global Positioning System, although this is a gross oversimplification of the technical details of that system. Another method of locating a target, where only the target’s direction from at least two such observation points is known, is commonly known as triangulation, where, with respect to each individual observation point, the target could be located anywhere on the respective rays shown in FIG. 1. If an observation point can determine both direction and distance, then it is possible to track a target using only a single observation point, which can be a significant advantage for reasons such as simplicity, budget, or availability of space and/or equipment. This approach forms the basis of early radar systems. However, practical systems are only able to discern a target’s distance and/or direction within certain accuracies. Accordingly, multiple direction-and-distance determining observation points are sometimes used in hybrid methods broadly described as “triangulation.”

A wireless electromagnetic signal propagates through free space at  $c$  ( $\sim 3 \times 10^8$  meters per second). By measuring the “time-of-flight” of the electromagnetic wave, i.e., the time it takes a portion of the wireless electromagnetic signal propagating from a source to reach a receiver, the distance from the source to that receiver can be calculated by the simple relationship  $d = t * c$ , where  $d$  is distance and  $t$  is time. For radar systems, where the target is a quasi-source that reflects or echoes a transmitted wireless electromagnetic signal, this technique is called pulse-delay ranging. The complication of measuring distance is that the receiver needs to know, at a minimum, when the pulse was initially transmitted from the actual source. This can be relatively simple in single observation point systems such as radar systems, where the transmitter and receiver can be co-located and thus share a signal source. However, in multiple observation point systems, each observation point, and also the target in some cases, has a separate signal source, and those signal sources must use clock synchronization or other techniques beyond relative locks to a received waveform to permit unambiguous calculations of distance. Wireless electromagnetic signal propagation can also be used to determine direction from a receiver to a source. Traditionally this would be done using a highly directional (narrow beamwidth) antenna that is mechanically rotated about a tracking area. Alternately, multiple omnidirectional or near-omnidirectional receiving antennas could be disposed in an array. Phased array antennas can be constructed using analog phase shifters for each antenna element and a combiner circuit that combines the phase shifted signals from each element. The relative phases of the antenna elements are varied by the phase shifters to sweep the look direction in the same manner that a mechanically rotated directional antenna would. A non-phased array antenna and system may instead separately analyze the signals from each antenna element to detect differences in the received phase, such as by performing an element-by-element, sequential phase analysis or electronically sampling the signals received by each antenna element, rather than steering the array look direction, effectively determining the direction of the received signal through minor differences in the time-of-flight to the individual antenna elements of the array.

The disclosed systems and methods are distance-and-direction-based technologies for tracking individuals (through a worn object), other objects, and/or nominally fixed locations in three dimensional space. With initial reference to FIG. 2, the system includes a transmitter 100 that transmits a first wireless electromagnetic signal 110. The system also includes a number of transponders 120 configured to receive the first wireless electromagnetic sig-



nal **110** and, in response, emit a second wireless electromagnetic signal **150**. Each transponder **120** may be a so-called-“bent-pipe transceiver,” meaning that the transponder includes a frequency shift stage that re-transmits received signals at a different frequency, such that the second wireless electromagnetic signal **150** is responsively emitted by the transponder at a different frequency relative to that of the first wireless electromagnetic signal **110**. The system further includes a receiver **170** that detects and processes the second wireless electromagnetic signals **150** emitted by the transponders **120** to determine a distance, azimuth or horizontal angle, and relative elevation or vertical angle between the receiver and the respective transponders **120**.

The transmitter **100** transmits the first wireless electromagnetic signal **110** in the radio or microwave frequency range. The transmitter **100** may transmit the signal at a frequency that can penetrate through buildings and other structures. In one case the transmitter **100** broadcasts in a frequency range between about 200 MHz and about 12000 MHz (including UHF, L band, S band, C band, and/or X band frequencies; for open-air and outdoor environments), or in another case a frequency range between about 200 MHz and about 1000 MHz (principally UHF frequencies; for developed environments), and in one particular case a frequency range of between about 420 MHz and about 450 MHz. The later represents a band that the United States Federal Communications Commission has allocated to radio location systems. The transmitter **100** may broadcast omnidirectionally in a range of power outputs, such as up to about 1 Watt in one construction. Greater power outputs may be used in open-air and outdoor environments. The transmitter may include a Field-Programmable Gate Array (FPGA), or other suitable integrated circuit such as an ASIC or Digital Signal Processor, for signal generation.

The first wireless electromagnetic signal **110** may in some cases comprise a pulsed signal and in other cases may comprise a frequency modulated continuous wave (FMCW). For a pulsed signal, the signal must be cycled on and off over an interval. The receiver **170**, discussed in detail below, then determines the time delay from when the transmitter **100** transmitted a particular pulse of the first wireless electromagnetic signal **110** (with transponders **120** receiving and responsively emitting a frequency-shifted second wireless electromagnetic signal **150**) and the receiver received a corresponding pulse of the second electromagnetic signal(s) **150** from the transponders **120**, e.g., by comparing the start or end times of reception of the respective signals. While the delays between pulses may be reduced depending upon the desired maximum range of the system, a fixed-frequency, non-encoded signal must be pulsed because otherwise only the relative phase of the electromagnetic signals **110**, **150** can be determined and the absolute distance of each transponder **120** will remain unknown. In contrast, for a FMCW signal **110**, a continuous wave signal has a frequency that is continuously swept across a first frequency band, i.e., between a lower bound of the first frequency band and a different, higher bound of the first frequency band. The receiver **170** then determines the time delay from when the transmitter **100** transmitted the first wireless electromagnetic signal **110** at a particular frequency within the first frequency band (with transponders **120** receiving and responsively emitting a frequency-shifted, frequency-modulated second wireless electromagnetic signal **150**) and the receiver received a second wireless electromagnetic signal **150** with a corresponding, frequency-shifted frequency within a second frequency band, i.e., a corresponding frequency between a lower bound of the second frequency band and a

different, higher bound of the second frequency band. For example, the first frequency band may span 10 MHz, e.g., from 420 to 430 MHz, and the second frequency band may span 10 MHz, e.g., from 435 to 445 MHz, or, if the transponders **120** include different frequency shifts as described below, may span 15 MHz, e.g., from 435 to 450 MHz, with individual transponders operating within some but not all of the second frequency band. The FMCW signal **110** offers the advantage that tracking may be continuous and that a comparatively large number of samples may be collected within a given time interval, allowing for errors to be averaged out and for an increase in the accuracy of an output of distance and direction. In addition, transmission hardware can be simplified by not having to pulse the first wireless electromagnetic signal **110**, and receiving hardware may be able to detect differences in frequency more accurately than differences in phase. Finally, depending upon the bandwidth of the first (and, correspondingly, second) frequency band, the system may be more resistant to sources of interference and multipath behaviors at specific frequencies.

The first wireless electromagnetic signal **110** may also comprise an orthogonal frequency division multiplexed (OFDM) signal. Such a signal **110** includes a plurality of sub-carriers which are distributed within a passband bandwidth of the complex OFDM signal (“orthogonally” such that the sub-carrier spacing is equal to the reciprocal of a symbol period). Advantageously, multipath effects associated with environmental obstructions or reflections will tend to affect each sub-carrier differently, such that some sub-carriers may experience relatively low multipath interference while others may experience relatively high multipath interference or so-called “deep fading.” By initially transmitting and, as described below, subsequently re-emitting a frequency-shifted version of an OFDM signal, the system may more accurately estimate the distance, azimuth, and relative elevation between the receiver and transponders **120**, for example, by averaging across individual sub-carrier-based estimates so as to decrease RMS error in an averaged estimate.

Upon receiving the first wireless electromagnetic signal **110**, the transponders **120** responsively emit the second wireless electromagnetic signal **150** in the radio or microwave frequency range. The transponders **120** may be unpowered devices such as so-called “passive” radio frequency identification (RFID) devices in one construction. However, as shown in FIG. 3, the transponders **120** may be self-powered devices, e.g., so-called “active” RFID devices, that include the aforementioned frequency shift stage, **126**, as well as a plurality of antennas (exemplary receiving antenna **122** and emitting antenna **138** are shown), a battery **132**, and a signal amplifier **136**. Such self-powered devices may advantageously emit the second wireless electromagnetic signal **150** with sufficient power to ensure propagation through buildings and other structures. The transponders **120** may emit omnidirectionally in a range of power outputs, such as up to about 0.1 Watt in one construction. The transponders **120** may emit at greater power outputs (after considering filter and amplifier limitations, power consumption/runtime requirements, and electromagnetic radiation safety concerns), however, the first wireless electromagnetic signal **110** may be significantly attenuated by intervening walls, equipment, and objects, so that the transponders should be able to detect a such a signal at just above the noise floor and amplify that signal within a wearable, compact, and lightweight device. Amplification to ~+10 dBm (with just over 100 dBm gain) permits the use of

off-the-shelf gain stages while maintaining reasonable size, weight, and emitter performance.

The frequency shift stage **126** receives signals such as the first wireless electromagnetic signal **110** and re-transmits them at a different frequency, such that the transponder **120** emits a signal, including the responsively emitted second wireless electromagnetic signal **150**, at a different frequency than that of the received signals. With respect to the first wireless electromagnetic signal **110**, the emission of a frequency-shifted second wireless electromagnetic signal **150** allows the transponders **120** to function as beacons and be tracked in cluttered and lossy indoor environments. The transponders **120** may emit at a comparatively different frequency than non-moving or slowly moving environmental responses to the first wireless electromagnetic signal **110**, distinguishing the second wireless electromagnetic signal(s) **150** from single- and multi-path reflections of the former signal. For example, the frequency shift stage **126** may shift the emitted signals by about 5, 10, or 15 MHz or more from the received signals. The reader will appreciate that the frequency shift may be quite small, as small as about 0.1% in some cases or less than about 1% in other cases, or less than about 10% in yet other cases. There are several advantages to keeping the frequency shift relatively small. First, the frequency range for the transmitter **100** may be selected to provide desirable properties for signal propagation, such as the ability to penetrate through buildings. By ensuring that the frequency range of the signal emitted by the transponders **120** is different than but close to the frequency range of the signal transmitted by the transmitter **100**, those desirable signal propagation qualities can be maintained. Secondly, in some cases only certain frequency bands are available or approved for use. Thus the use of other similar frequencies can help to ensure that the entire system operates within a relatively narrow band of frequencies approved for use, making approval of use and compliance with operating restrictions easier.

In one construction, the frequency shift stage **126** includes an oscillator **128** and a first mixer **130**, whereupon the stage mixes received signals with the output of the oscillator via the first mixer to re-transmit a frequency downshifted or upshifted signal. Accordingly, the transponders **120** may be purely analog transponders and lack any digital electronics, digital processing circuitry, digital signal processors, or the like. Other constructions, including constructions using digital signal processors to analyze the first wireless electromagnetic signal **110** and to digitally construct the second wireless electromagnetic signal **150**, will be apparent to those of skill in the art. However, the disclosed “analog” transponders have the advantage that they may be used with any transmitter **100** that transmits within an appropriate frequency range, regardless of signal type, and need not understand or be updated to understand different or new signal schemes. Each transponder **120**, via the oscillator **128**, may be configured to emit the second wireless electromagnetic **150** signal at a different frequency relative to that of the first wireless electromagnetic signal **110** and the frequencies of the second wireless electromagnetic signals emitted by the other transponders. In one construction, the oscillator **128** may be a resistor-set adjustable oscillator, although other types of adjustable oscillator will be apparent to those of skill in the art. In one construction, the oscillator **128** may be a pluggable module, such that different oscillators may be substituted to provide different frequencies relative to that of the first wireless electromagnetic signal **110** and the frequencies of the second wireless electromagnetic signals emitted by the other transponders. For example,

each transponder **120** may provide a shift in frequency including a base shift, e.g., 10 MHz from the transmitted frequency, and an incremental shift, e.g. 5 or 10 kHz, from the emitted frequencies of others of the plurality of transducers. The different-frequency second wireless electromagnetic signals allow individual transponders **120**, and therefore individual persons or objects, to be tracked through the emitted frequency corresponding to that specific transponder. Although a difference of 5 kHz can provide some overlap in the emitted signals, different signals are able to be identified by the receiver **170**.

The plurality of antennas, e.g., receiving antenna **122** and emitting antenna **138**, may take various forms. A first construction may use patch antennas. A second construction may use a spiral antenna, such as a compact, PCB-borne spiral antenna disclosed in Compact Spiral Antenna for Space Based Applications, Antennas and Propagation Society International Symposium (APSURSI), IEEE 2014 (DOI 10.1109/APS.2014.6905180), developed by Kevin Zack et al. Separate receiving **122** and emitting **138** antennas may be disposed on opposite sides of a multilayer PCB containing a layered ground plane and vias to minimize inter-antenna coupling. A third construction uses two concentric patch antennas operated in a differential configuration. A fourth construction uses conventional monopole antennas. The referenced patch and spiral antennas are at least somewhat directional, and as a result the transponders **120** may include multiple antennas that may be disposed, for example, dorsally and ventrally on an individual, or the system may use multiple transponders disposed, for example, dorsally and ventrally on the individual. The referenced monopole antennas are omnidirectional, but frequently require that the transponder **120** include a projecting antenna rather than an internally-housed antenna.

The transponders **120** may include a receive filter **124** that limits the received signals to a set frequency range encompassing the first wireless electromagnetic signal **110**. The receive filter **124** may remove undesired sources of interference and ensure that the transponder **120** does not oscillate due to its own emissions. The transponders **120** may also include an emission filter **134** to block undesired emissions and/or further reduce the potential for the transponder to oscillate due to its own emissions. In systems with both high gain (e.g., the exemplary 100 dBm gain mentioned above) and closely spaced transmitter and emitter frequencies, there should be a comparable degree of isolation between the receiving side and the emitting side, otherwise portions of the emitted signal may be the strongest signal passed to the frequency shift stage **126**, and the transponders **120** may oscillate rather than function as bent-pipe transceivers. For constructions in which the frequency shift is relatively large, e.g., from a transmitting frequency of ~400 MHz to a frequency-doubled emitted frequency of ~800 MHz, the filters **124**, **134** may include chip capacitors and inductors arranged to form a 3-5 pole discrete filter. However, for constructions in which the frequency shift is relatively small, the filters **124**, **134** may include a high Q-factor filter (where the Q factor=the filter center frequency divided by the bandwidth passed by the filter). The receive filter **124** should have considerable attenuation at the emitting frequency of the transponder **120**. Because the frequency shift stage **126** and signal amplifier **136** will amplify system noise, the emission filter **134** should have considerable attenuation at the transmitting frequency of the transmitter **100**.

In one construction the filters **124** and **134** include so-called Surface Acoustic Wave (SAW) filters. In the case of

the receive filter **124**, a SAW filter may provide, for example, a 10 MHz passband centered at 425 MHz, 3-5 dB insertion loss in the passband, and >40 dB rejection outside the passband. FIG. 4 illustrates the performance of a prototype, exemplary SAW filter, while SAW filters are available for other frequency ranges. In the case of the emission filter **134**, another SAW filter may be used to provide a filter with a 15 MHz passband centered at 442.5 MHz, 3-7 dB insertion loss in the passband, and >40 dB rejection outside the passband. FIG. 5 illustrates the performance of a prototype, exemplary SAW filter, while, again, SAW filters are available for other frequency ranges. Multiple filter elements may be cascaded to meet attenuation/rejection requirements, and amplifier elements may be inserted between such filters to minimize amplifier compression and noise. Surface-Skimming Bulk Wave SAW filters may be particularly suitable for the transponders **120**, since they have decreased susceptibility to filter substrate impurities, have lower losses, and are less susceptible to temperature effects than traditional SAW filters.

In another construction, the filters **124** and **134** include coaxial resonator filters. In the case of the receive filter **124**, a seven-resonator, chip capacitor-coupled coaxial filter may provide, for example, a 10 MHz passband centered at 425 MHz, low insertion loss in the passband, and exponentially increasing rejection outside the passband (>20 dB at 435 MHz). FIG. 6 illustrates the performance of a prototype, exemplary filter, while coaxial resonator filters are available for other frequency ranges. In the case of the emission filter **134**, another such filter may provide a 15 MHz passband centered at 442.5 MHz. As with SAW filters, multiple filter elements may be cascaded to meet attenuation/rejection requirements, and amplifier elements may be inserted between such filters to minimize amplifier compression and noise. Alternately, a single filter may be tuned using a parallel, adjustable capacitance to alter each resonator's resonant frequency to improve rejection. The reader will appreciate that coaxial resonator filters may alternately be formed using lengths of coaxial cable, with the cable being sized to  $\frac{1}{4}$  of the passband-centered wavelength (and short-circuited at one end to form a quarter wavelength resonator) or  $\frac{1}{2}$  of the passband-centered wavelength (and left open at one end to form a half wavelength resonator), however those elements will be physically larger (e.g., ~4.5 inches for the 420-450 MHz frequency band in quarter wavelength mode, ~9 inches in half wavelength mode) and losses will be higher. In order to reduce the areal extent of the filter, fine-diameter coaxial cables may be coiled into a helical configuration. Since the performance of such coaxial-cable-based resonator filters will be dependent upon variance about the design length, the cable-based resonator may also be tuned using a parallel, adjustable capacitance to alter the cable's resonant frequency and improve rejection. FIG. 7 shows an exemplary resonator unit **200** for a PCB-mounted cable-based resonator. The unit includes a signal line **210**, a split **212** that interconnects the signal line **210** to a coaxial cable **220** and adjustable capacitor **230**, and first and second ground planes, **240**, **250**, respectively. The center conductor **222** of the coaxial cable **220** is connected to the split **212** and the shield **224** is connected to the first ground plane **240**. The adjustable capacitor is connected to the split **220** and the second ground plane **250**. First and second chip capacitors **214**, **216** may be provided on the signal line **210** before and after the split **212** so that the unit may be tuned in isolation from the effects of other such units in a multiple resonator coaxial filter.

## Transponder Working Example 1

FIG. 8 is a schematic illustration of a working example **300** of a transponder **120**. The receive side of the transponder includes an ultra-low noise amplifier **310** (Mini-Circuits PMA2-33LN+) which increases the gain of the signal received by a receiving antenna **122** and reduces the susceptibility of the signal to amplifier-introduced noise. The output of the amplifier **310** is passed to a receive filter **124** which includes a series of SSBW SAW filters **320** (passing the first frequency band) and wideband amplifiers **330** (NXP Semiconductors BGA 2817) to provide further amplification while reducing the effects of amplifier compression and amplifier-introduced noise. The output of the receive filter **124** is passed to a first mixer **130** (Mini Circuits ADEX-10L+) where an adjustable oscillator **128** (Linear Technologies LTC1799) provides a 1 kHz to 33 MHz feed to the local oscillator port. The frequency-shifted output of the first mixer is passed to an emission filter **134** which includes a series of SSBW SAW filters **340** (passing the second frequency band) and wideband amplifiers **330** (NXP Semiconductors BGA 2817) to provide emission amplification while reducing noise transmitted around the emitted frequency. The output of the emission filter **134** is passed to a signal amplifier **136** (Qorvo RF2637) that may include automatic gain control so as to prevent unnecessary amplification and consumption of device power. The reader will note that there may be a final emission filter-like element to reject noise potentially introduced into the signal by the signal amplifier **136**. The output of the signal amplifier **136** is otherwise passed to the emitting antenna **138** for broadcast and reception by the receiver **170** of the system.

FIG. 9 is a time-averaged power spectral density (PSD) plot of the received and emitted signals of the transponder of the working example of FIG. 8, simulated via a model in National Instruments' AWR Visual Systems Simulator with a thermal noise floor of -144 dBm to simulate one extreme of the device's dynamic range. The bottom, received signal, at 425 MHz, is frequency shifted to 435 MHz with ~90 dB of gain. Power detector and AGC control circuits may be used to add up to 50 dB of additional gain via the Qorvo RF2637 to achieve a steady +10 dBm output.

## Transponder Working Example 2

The transponders **120** may include an intermediate frequency (IF) stage **140** so that existing commercial filters may be used. Also, since Q factor is a measure of fractional bandwidth, it is frequently possible to for a given filter technology to achieve a narrower passband at lower passband center frequencies. The intermediate frequency stage may further include a pre-filter **142**, which may be a low Q-factor filter, to reject noise potentially introduced into the signal by the IF stage **140** and prevent out-of-band (transmission and emission band) signal emissions. With reference to FIG. 10, a working example **400** of another transponder **120** has a receive side that includes an ultra-low noise amplifier **410** (Mini-Circuits PMA2-33LN+), as otherwise described in working example 1 above. The output of the amplifier **410** is passed to an intermediate frequency stage **140** that includes a pre-filter **142** that may comprise a series of capacitors and inductors since strong isolation of the received signal is not yet required. The output of the pre-filter is passed to the second mixer **144** (The intermediate frequency stage **140** includes a second mixer **144** (in a subordinate, not sequential sense; Mini Circuits ADEX-10L+) where a local oscillator **146** (e.g., 348.5 MHz refer-

## 11

ence oscillator) provides feed to the local oscillator port. The frequency-downshifted output of the second mixer **164** is passed to a receive filter **124** which includes a series of SAW filters **420** (MuRata SF2038B) and wideband amplifiers **430** (NXP Semiconductors BGA 2817) to provide further amplification while reducing the effects of amplifier compression and amplifier-introduced noise. The output of the receive filter **124** is passed to a first mixer **126** (Mini Circuits ADEX-10L+) where an adjustable oscillator **128** (Linear Technologies LTC1799) provides an 368.5 MHz feed (adjustable to lesser and greater frequencies to provide different emitted frequencies) to the local oscillator port. The frequency-shifted output of the first mixer **126** is passed, without use of an emission filter **134**, to a signal amplifier **136** that, in this construction, includes a series of wideband amplifiers **430** (NXP Semiconductors BGA 2817s with a final Mini-Circuits PMA2-33LN+ to avoid signal compression). The reader will appreciate that, as in working example 1 above, a signal amplifier **136** including automatic gain control could be substituted within the series. The reader will note that there may be a final low-Q filter element to reject noise potentially introduced into the signal by the signal amplifier **136** and prevent out-of-band (transmission and emission band) signal emissions. The output of the signal amplifier **136** is otherwise passed to the emitting antenna **138** for broadcast and reception by the receiver **170** of the system.

FIG. **11** is a time-averaged power spectral density (PSD) plot of the received and emitted signals of the transponder of the working example, again simulated via a model in Visual Systems Simulator with a thermal noise floor of  $-144$  dBm. From the left hand side of the figure, the bottom, received signal, at 425 MHz, is frequency shifted to the middle, emitted signal, at 445 MHz with  $\sim 110$  dB of gain. The top, intermediate frequency signal is shown for reference, but not significantly emitted by the transponder.

The reader will appreciate that the aforescribed amplifier and filter elements may be included in various orders and combinations based upon a target frequency shift, a target gain, a target isolation between received and emitted signals, the performance characteristics of commercially available versus custom components, and the like. The components may be interconnected with coplanar waveguides or conductor-backed waveguides so as to have an  $\sim 50$  Ohm impedance with line widths compatible with surface mount components. For example, the working examples employ a 1.6 mm FR4 PCB with a 57.5 mil conducting track linewidth, 10 mil gaps to the return conductors, and 0.7 mil line thickness to provide a 55 Ohm circuit that could be interfaced directly with discrete chip components. Coplanar waveguides and conductor-backed waveguides also advantageously allow for increased isolation between the stages of the transducer **120** due to the presence of return conductors, the ground plane, and/or stitching vias.

The transponder electronics, potentially including the antennas **122** and **138**, are contained within a housing **160**, such the one shown in FIG. **12**. The housing **160** should be transparent to the radio and/or microwave frequency range, based upon the frequencies of the first and second wireless electromagnetic signals, and may be constructed from fiberglass or nylon weave, for example. The battery **132** may be a removable battery with a non-flammable electrolyte chemistry, such as LiFePO<sub>4</sub> 32650 cells or alkaline C and D cells. The housing **160** may include a port **162** through which an adjustable oscillator **128** may be set or a modular, pluggable oscillator **128** may be substituted in order to set the fre-

## 12

quency of the emitted, second wireless electromagnetic signal of the transponder **120**.

The receiver **170** receives and detects the response signals emitted by the transponders **120**. As noted above, the emitted second wireless electromagnetic signals **150** are frequency-shifted from the transmitted first wireless electromagnetic signal **110**, making the response signals easy to identify and enabling the transponders **120** to act as beacons. In addition, as noted above, the response signals emitted by each transponder **120** may be uniquely frequency shifted relative to all of, or even only some of, the other transponders in the system, enabling the receiver to identify individual transponders and persons. The beacon-like quality of the response signal emitted by each transponder **120** enables the receiver **170** to identify azimuth (or horizontal angle) of the beacon/transponder, the relative elevation (or vertical angle) of the beacon/transponder, and the time-of-flight of response signals emitted by the beacon/transponder.

The receiver **170**, an example of which is shown in FIG. **13**, includes at least three receiving antenna elements **172** arranged about a center point. A calibration antenna **174** may be disposed proximate to the center point so that a sample signal may be broadcast from the calibration antenna and phase measurements taken at the receiving antenna elements **172**. The reader will appreciate that the exemplary antenna system may be used to identify the horizontal angles or azimuths to the transponders **120** and the times-of-flight of response signals emitted by the transponders, but not the vertical angles or altitudes of the transponders. At least one additional receive antenna element **172** may be disposed above or below the illustrated antennas to permit identification of such vertical angles or altitudes. In one construction, the receive antenna elements may be configured as a pyramid, e.g., a triangular, square, or higher-edge-numbered, regular or potentially irregular pyramidal arrangement. In another construction, the receive antenna elements **172** may be configured as a bipyramid, e.g., a triangular, square, or higher-edge-numbered, regular or potentially irregular bipyramidal arrangement. In yet another construction, the receive antenna elements **172** may be configured in two or more vertically-separated layers, with the layers being arranged identically, in a rotated aspect, or potentially differently with respect to other layers. The arrangement of the receiving antenna elements **172** is used to triangulate or triangulate the location of the transponders **120**. The calibration antenna **174** may be used to normalize any variance in the receiving electronics of the receiver based upon the known arrangement of receiving and calibration antennas.

The receiver **170** may include a Field-Programmable Gate Array (FPGA), or other suitable integrated circuit such as an ASIC or Digital Signal Processor, for signal analysis. By measuring the overall phase delay between the transmitted first wireless electromagnetic signal **110** and the emitted second wireless electromagnetic signals **150**, the distances to the transducers **120** can be calculated. So long as the placement of the transmitter **100** relative to the receiver **170** is known, the difference in time-of-flight of the first wireless electromagnetic signal **110** from the transmitter **100** to a respective transponder **120** from the time-of-flight of the second wireless electromagnetic signal **150** from the respective transponder **120** to the receiver **170** can be accounted for and distance to the respective transponder identified. By measuring the relative phase of respective second wireless electromagnetic signals **150** at each receiving antenna element **172**, at least an approximate horizontal angle or azimuth to the respective transponder **120** can be identified.

For example, as shown in FIG. 12, a vector drawn from the receiving antenna 172a measuring the greatest phase shift to the receiving antenna 172b measuring the least phase shift will point approximately toward the respective transponder. Interpolation, or in arrangements such as the aforementioned pyramidal, bipyramidal, or layered arrangements of receiving antennas 172, triangulation, triangulation, or other mathematical techniques based upon models of the arrangement, may be used for to increase the accuracy of the identified horizontal angle or azimuth and vertical angle or elevation. In cases where the transmitted first wireless electromagnetic signal 110 and the emitted second wireless electromagnetic signals 150 comprise OFDM signals, such methods may be applied to each of the plurality of sub-carriers of the second wireless electromagnetic signal 150 and simple averages of the estimated distance, azimuth or horizontal angle, and relative elevation or vertical angle, respectively, used to reduce the RMS error of the averaged estimate. Alternately, the OFDM signal components may be analyzed and any significantly delayed/obscured sub-carrier signals rejected, with such methods being applied to the remainder of the plurality of sub-carriers of the second wireless electromagnetic signal 150 so that qualified averages of the estimated distance, azimuth or horizontal angle, and relative elevation or vertical angle are determined.

The receiver 170 may be operatively coupled to the transmitter 100 (and, if not physically coupled to the transmitter, programmed to determine or receive as an input the distance between the two) so that the receiver can determine and analyze time-of-flight information for wireless electronic signals emitted by each transponder 120; and in this manner analyze the distance to the various transponders. For instance, the receiver 170 and transmitter 100 may be disposed upon the same vehicle, such as a firetruck, or upon the same vehicle-towable carrier, such as a trailer. Alternately, the receiver 170 and transmitter 100 may be coupled to separate vehicles, to a vehicle and separable vehicle-towable carrier, or to separate moveable carriers, such as protective or so-called hard cases. When disposed upon the same vehicle or towable carrier, the distance and relative orientation of the receiver 170 and transmitter 100 may be known and pre-programmed into the system, allowing the system to determine and subtract time-of-flight of the first wireless signal 150 from the transmitter 100 respective transponders 120. When disposed on separate or separable carriers, GPS locators may be used to locate and supply the locations of the receiver 170 and transmitter 100 to the system, or the system may be programmed to self-determine the distance and relative direction of the transmitter 100 from the receiver 170. Since each transponder 120 can be relatively simple and analog, there is no (or very little) delay for each transponder between receiving the wireless electromagnetic signals transmitted by the transmitter and emitting its own wireless electromagnetic signal in response. Moreover, if there is any sort of delay, again since the transponder can be analog and very simple, the delay can be known and predictable, and can be easily accounted for in time-of-flight calculations. Thus, by determining the elevation, the azimuth, and the distance to the emitter of a response signal, the location of each transponder 120 can be determined in a three dimensional space.

The receiver 170 is configured to produce an output that may be communicated to a human user in a variety of manners. In one case the receiver 170 is operatively coupled to a display screen or an output device such as a tablet device, a mobile phone, a desktop computer, a laptop computer, or the like. In this case a 2-D (including a

numerical representation of relative elevation) or 3-D representation of the surrounding space may be provided and displayed, and the position of each transponder 120 (and/or the individual or item to which the transponder is attached) also displayed relative to the surrounding space. The locations of transponders 120 relative to each other and/or the building and/or other geographic indicators, such as streets or GIS data, can be provided. The locations of each of the transponders 120 may be displayed, or only certain operator-selected transponders, based on their qualities/characteristics (e.g., firefighters within a certain battalion; first responders other than firefighters or vice versa, firefighters showing certain risk factors, or the like). Identifying information may also be displayed; for example the name of each individual may be displayed, or may be available for display if selected by the operator.

A variety of public service and industrial occupations may benefit from a tracking system capable of precisely tracking the location and movement of various individuals or objects in mixed indoor/outdoor worksites. The present field-deployable system specifically addresses the needs of tracking personnel working in such mixed indoor/outdoor environments, and can increase the safety and efficiency of personnel working at such sites, especially in the case of critical operations such as firefighting or first response. Individuals can be alerted if they are entering an unsafe area; help can be sent if an individual is determined to not be moving; and the location of injured or incapacitated individuals can be accurately reported in order to assist with rescue by others.

Having described the invention in detail and by reference to the various embodiments, it should be understood that modifications and variations thereof are possible without departing from the scope of the claims of the present application.

What is claimed is:

1. A system for determining a location of an individual in three dimensional space, the system comprising:

a transmitter for transmitting a first wireless electromagnetic signal having a first signal frequency, wherein the transmitter sweeps in frequency within a first frequency band including the first signal frequency, wherein the first wireless electromagnetic signal is transmitted within the first frequency band selected to propagate through a building and is transmitted at a power level selected to propagate through the building and towards the individual;

a plurality of wearable-transponders each configured to be worn by a corresponding individual entering the building, wherein each of the plurality of wearable-transponders is configured, in response to receiving the first wireless electromagnetic signal having the first signal frequency from the transmitter, to emit a second wireless electromagnetic signal having a second signal frequency that is frequency-shifted from the first signal frequency, wherein the second wireless electromagnetic signal comprises a frequency-shifted, repeated version of the first wireless electromagnetic signal, wherein the second signal frequency, at which each of the plurality of wearable-transponders emits its respective second wireless electromagnetic signal, includes a base frequency shift and an incremental frequency shift, wherein the incremental frequency shift is unique to each of the plurality of wearable-transponders to enable identification of each of the plurality of wearable-transponders from the other of the plurality of wearable-transponders;

15

wherein each of the plurality of wearable-transponders comprises:

- a receive antenna configured to receive, in the first frequency band, the first wireless electromagnetic signal,
  - a low-noise amplifier coupled to the receive antenna, an intermediate frequency stage coupled to the output of the low noise amplifier, wherein the intermediate stage mixes the first wireless electromagnetic signal received by the receive antenna to produce one or more intermediate frequency electromagnetic signals to enable intermediate frequency processing of the one or more intermediate frequency electromagnetic signals,
  - a frequency shift stage coupled to the intermediate frequency stage, wherein the frequency shift stage mixes the processed one or more intermediate electromagnetic signals to produce the second wireless electromagnetic signal, and
  - a transmit antenna configured to transmit, in a second frequency band, the second wireless electromagnetic signal, and
  - a receiver for detecting the first and second wireless electromagnetic signals, wherein the receiver is configured, based upon detection of the first and second wireless electromagnetic signals, to provide an output of location information for at least one of the plurality of wearable-transponders.
2. The system of claim 1, wherein the first wireless electromagnetic signal comprises a frequency modulated continuous wave, and the second wireless electromagnetic signal comprises a frequency-shifted version of the frequency modulated continuous wave.
3. The system of claim 1, wherein the transmitter is configured to transmit the first wireless electromagnetic signal with a first signal frequency of between 200 MHz and 1000 MHz.
4. The system of claim 1, wherein the first frequency band is from 420 MHz to 430 MHz.
5. The system of claim 1, wherein the frequency shift stage comprises an oscillator and a first mixer configured to produce the second wireless electromagnetic signal.

16

6. The system of claim 5, wherein to provide the base frequency shift and the incremental frequency shift such that the incremental frequency shift is unique to each of the plurality of wearable-transponders, the oscillator of each of the plurality of wearable-transponders has a different frequency relative to the oscillators of each of the others of the plurality of wearable-transponders.

7. The system of claim 6, wherein the oscillator comprises at least one oscillator adjustable to a plurality of different frequencies.

8. The system of claim 1, wherein each of the plurality of wearable-transponders is configured to emit the second wireless electromagnetic signal with a second signal frequency of between 200 MHz and 1000 MHz.

9. The system of claim 8, wherein the second wireless electromagnetic signal is transmitted in a second frequency band between 435 MHz and 450 MHz.

10. The system of claim 9, wherein the first signal frequency and the second signal frequency differ by at least 5 MHz.

11. The system of claim 1, wherein the receiver includes a plurality of antenna elements distributed across a three dimensional volume of space, and the receiver is configured to estimate a distance, a horizontal angle, and a vertical angle between the receiver and a respective one of the plurality of wearable-transponders based upon analysis of a phase delay between the first wireless electromagnetic signal and the second wireless electromagnetic signal as received by the plurality of antenna elements.

12. The system of claim 11, wherein the receiver includes a phased array antenna comprised of the plurality of antenna elements.

13. The system of claim 11, wherein the receiver includes a non-phased array antenna comprised of the plurality of antenna elements, and the receiver is configured to separately analyze the phase delay for each of the plurality of antenna elements.

14. The system of claim 1, wherein the receiver includes a display screen, and the output is a representative output on the display screen showing the location of individual ones of the plurality of wearable-transponders.

\* \* \* \* \*