



US010980507B2

(12) **United States Patent**  
**Al-Ali et al.**

(10) **Patent No.:** **US 10,980,507 B2**  
(45) **Date of Patent:** **Apr. 20, 2021**

(54) **PHYSIOLOGICAL ACOUSTIC MONITORING SYSTEM**

(71) Applicant: **MASIMO CORPORATION**, Irvine, CA (US)

(72) Inventors: **Ammar Al-Ali**, San Juan Capistrano, CA (US); **Sung Uk Lee**, Irvine, CA (US)

(73) Assignee: **Masimo Corporation**, Irvine, CA (US)

(\*) Notice: Subject to any disclaimer, the term of this patent is extended or adjusted under 35 U.S.C. 154(b) by 172 days.

(21) Appl. No.: **16/159,395**

(22) Filed: **Oct. 12, 2018**

(65) **Prior Publication Data**

US 2019/0254622 A1 Aug. 22, 2019

**Related U.S. Application Data**

(63) Continuation of application No. 15/184,951, filed on Jun. 16, 2016, now Pat. No. 10,098,610, which is a (Continued)

(51) **Int. Cl.**

**A61B 5/00** (2006.01)

**A61B 7/00** (2006.01)

(Continued)

(52) **U.S. Cl.**

CPC ..... **A61B 7/003** (2013.01); **A61B 5/0022** (2013.01); **A61B 5/02416** (2013.01); **A61B 5/6822** (2013.01); **A61B 5/725** (2013.01); **A61B 5/742** (2013.01); **A61B 5/746** (2013.01); **A61B 7/04** (2013.01); **G10L 19/00** (2013.01); **A61B 5/0004** (2013.01); **A61B 5/082** (2013.01); **A61B 5/0803** (2013.01); **A61B 5/0816** (2013.01);

(Continued)

(58) **Field of Classification Search**

CPC ... A61B 5/725; A61B 5/0022; A61B 5/02416; A61B 5/6822; A61B 5/742; A61B 5/746; A61B 5/0803; A61B 5/082; A61B 5/0823; A61B 7/003; A61B 7/04; G01L 19/00

See application file for complete search history.

(56) **References Cited**

**U.S. PATENT DOCUMENTS**

4,960,128 A 10/1990 Gordon et al.

4,964,408 A 10/1990 Hink et al.

(Continued)

*Primary Examiner* — Max F Hindenburg

(74) *Attorney, Agent, or Firm* — Knobbe Martens Olson & Bear, LLP

(57) **ABSTRACT**

A physiological acoustic monitoring system receives physiological data from an acoustic sensor, down-samples the data to generate raw audio of breathing sounds and compresses the raw audio. The acoustic monitoring system has an acoustic sensor signal responsive to tracheal sounds in a person. An A/D converter is responsive to the sensor signal so as to generate breathing sound data. A decimation filter and mixer down-samples the breathing sound data to raw audio data. A coder/compressor generates compressed audio data from the raw audio data. A decoder/decompressor decodes and decompresses the compressed audio data into decompressed audio data. The decompressed audio data is utilized to generate respiration-related parameters in real-time. The compressed audio data is stored and retrieved so as to generate respiration-related parameters in non-real-time. The real-time and non-real-time parameters are compared to verify matching results across multiple monitors.

**12 Claims, 11 Drawing Sheets**

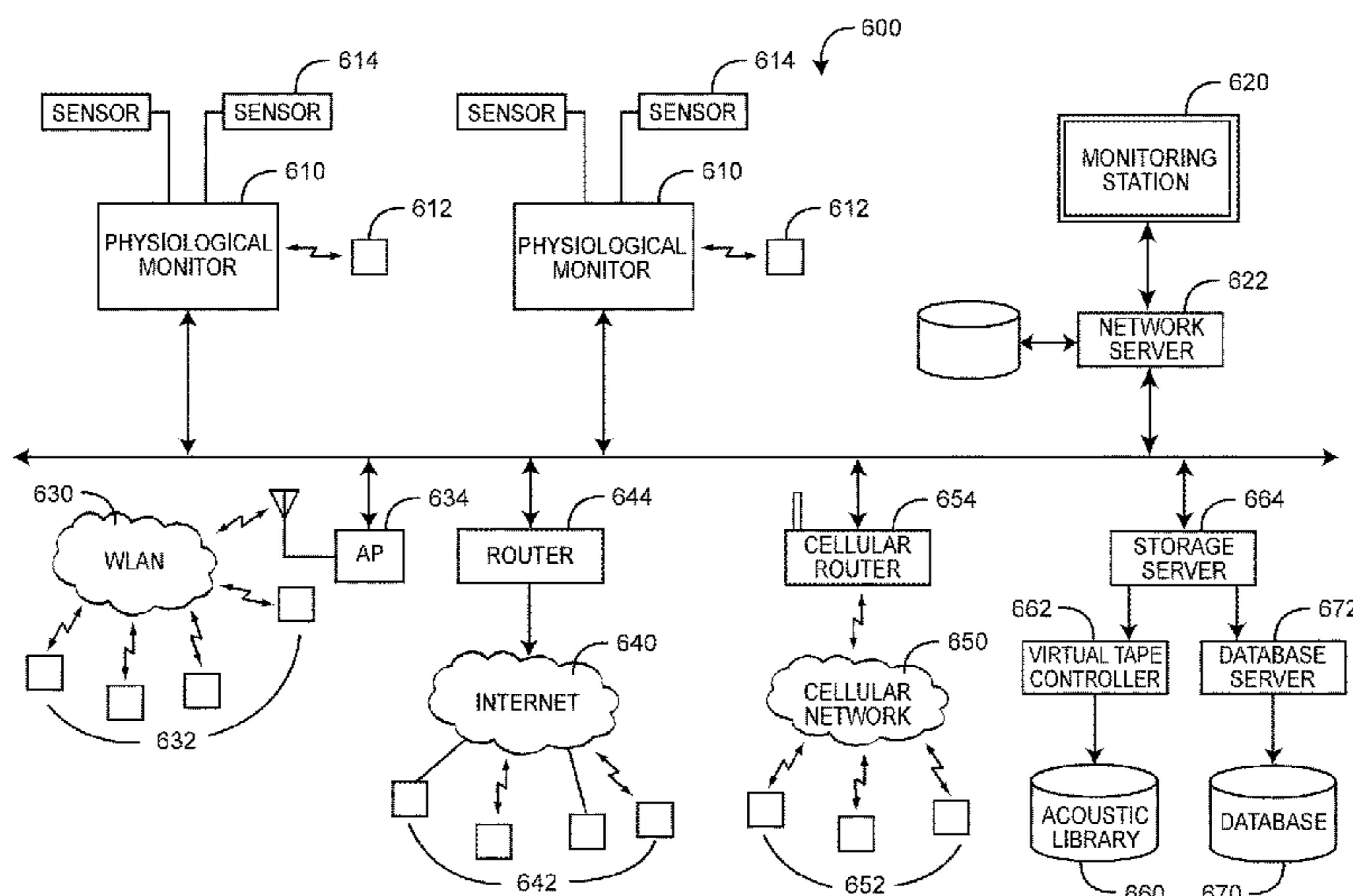

**Related U.S. Application Data**

continuation of application No. 14/522,474, filed on Oct. 23, 2014, now Pat. No. 9,370,335, which is a continuation of application No. 13/650,775, filed on Oct. 12, 2012, now Pat. No. 8,870,792, which is a continuation-in-part of application No. 12/905,036, filed on Oct. 14, 2010, now Pat. No. 8,821,415.

(60) Provisional application No. 61/547,007, filed on Oct. 31, 2011, provisional application No. 61/391,098, filed on Oct. 8, 2010, provisional application No. 61/252,099, filed on Oct. 15, 2009.

(51) **Int. Cl.**

*A61B 7/04* (2006.01)  
*G10L 19/00* (2013.01)  
*A61B 5/024* (2006.01)  
*A61B 5/08* (2006.01)

(52) **U.S. Cl.**

CPC ..... *A61B 5/0823* (2013.01); *A61B 5/7225* (2013.01); *A61B 5/7232* (2013.01); *A61B 5/7278* (2013.01); *A61B 5/7405* (2013.01); *A61B 5/7415* (2013.01)

(56) **References Cited**

U.S. PATENT DOCUMENTS

5,041,187 A 8/1991 Hink et al.  
 5,069,213 A 12/1991 Polczynski  
 5,163,438 A 11/1992 Gordon et al.  
 5,319,355 A 6/1994 Russek  
 5,337,744 A 8/1994 Branigan  
 5,341,805 A 8/1994 Stavridi et al.  
 D353,195 S 12/1994 Savage et al.  
 D353,196 S 12/1994 Savage et al.  
 5,377,676 A 1/1995 Vari et al.  
 D359,546 S 6/1995 Savage et al.  
 5,431,170 A 7/1995 Mathews  
 D361,840 S 8/1995 Savage et al.  
 D362,063 S 9/1995 Savage et al.  
 5,452,717 A 9/1995 Branigan et al.  
 D363,120 S 10/1995 Savage et al.  
 5,456,252 A 10/1995 Vari et al.  
 5,479,934 A 1/1996 Imran  
 5,482,036 A 1/1996 Diab et al.  
 5,490,505 A 2/1996 Diab et al.  
 5,494,043 A 2/1996 O'Sullivan et al.  
 5,533,511 A 7/1996 Kaspari et al.  
 5,534,851 A 7/1996 Russek  
 5,561,275 A 10/1996 Savage et al.  
 5,562,002 A 10/1996 Lalin  
 5,590,649 A 1/1997 Caro et al.  
 5,602,924 A 2/1997 Durand et al.  
 5,632,272 A 5/1997 Diab et al.  
 5,638,816 A 6/1997 Kiani-Azarbayjany et al.  
 5,638,818 A 6/1997 Diab et al.  
 5,645,440 A 7/1997 Tobler et al.  
 5,685,299 A 11/1997 Diab et al.  
 D393,830 S 4/1998 Tobler et al.  
 5,743,262 A 4/1998 Lepper, Jr. et al.  
 5,758,644 A 6/1998 Diab et al.  
 5,760,910 A 6/1998 Lepper, Jr. et al.  
 5,769,785 A 6/1998 Diab et al.  
 5,782,757 A 7/1998 Diab et al.  
 5,785,659 A 7/1998 Caro et al.  
 5,791,347 A 8/1998 Flaherty et al.  
 5,810,734 A 9/1998 Caro et al.  
 5,823,950 A 10/1998 Diab et al.  
 5,830,131 A 11/1998 Caro et al.  
 5,833,618 A 11/1998 Caro et al.  
 5,860,919 A 1/1999 Kiani-Azarbayjany et al.  
 5,890,929 A 4/1999 Mills et al.  
 5,904,654 A 5/1999 Wohltmann et al.

5,919,134 A 7/1999 Diab  
 5,934,925 A 8/1999 Tobler et al.  
 5,940,182 A 8/1999 Lepper, Jr. et al.  
 5,987,343 A 11/1999 Kinast  
 5,995,855 A 11/1999 Kiani et al.  
 5,997,343 A 12/1999 Mills et al.  
 6,002,952 A 12/1999 Diab et al.  
 6,011,986 A 1/2000 Diab et al.  
 6,027,452 A 2/2000 Flaherty et al.  
 6,036,642 A 3/2000 Diab et al.  
 6,045,509 A 4/2000 Caro et al.  
 6,067,462 A 5/2000 Diab et al.  
 6,081,735 A 6/2000 Diab et al.  
 6,088,607 A 7/2000 Diab et al.  
 6,110,522 A 8/2000 Lepper, Jr. et al.  
 6,124,597 A 9/2000 Shehada  
 6,128,521 A 10/2000 Marro et al.  
 6,129,675 A 10/2000 Jay  
 6,144,868 A 11/2000 Parker  
 6,151,516 A 11/2000 Kiani-Azarbayjany et al.  
 6,152,754 A 11/2000 Gerhardt et al.  
 6,157,850 A 12/2000 Diab et al.  
 6,165,005 A 12/2000 Mills et al.  
 6,184,521 B1 2/2001 Coffin, IV et al.  
 6,206,830 B1 3/2001 Diab et al.  
 6,229,856 B1 5/2001 Diab et al.  
 6,232,609 B1 5/2001 Snyder et al.  
 6,236,872 B1 5/2001 Diab et al.  
 6,241,683 B1 6/2001 Macklem et al.  
 6,253,097 B1 6/2001 Aronow et al.  
 6,256,523 B1 7/2001 Diab et al.  
 6,263,222 B1 7/2001 Diab et al.  
 6,278,522 B1 8/2001 Lepper, Jr. et al.  
 6,280,213 B1 8/2001 Tobler et al.  
 6,285,896 B1 9/2001 Tobler et al.  
 6,301,493 B1 10/2001 Marro et al.  
 6,308,089 B1 10/2001 von der Ruhr et al.  
 6,317,627 B1 11/2001 Ennen et al.  
 6,321,100 B1 11/2001 Parker  
 6,325,761 B1 12/2001 Jay  
 6,334,065 B1 12/2001 Al-Ali et al.  
 6,343,224 B1 1/2002 Parker  
 6,349,228 B1 2/2002 Kiani et al.  
 6,360,114 B1 3/2002 Diab et al.  
 6,368,283 B1 4/2002 Xu et al.  
 6,371,921 B1 4/2002 Caro et al.  
 6,377,829 B1 4/2002 Al-Ali  
 6,388,240 B2 5/2002 Schulz et al.  
 6,397,091 B2 5/2002 Diab et al.  
 6,430,437 B1 8/2002 Marro  
 6,430,525 B1 8/2002 Weber et al.  
 6,463,311 B1 10/2002 Diab  
 6,470,199 B1 10/2002 Kopotic et al.  
 6,501,975 B2 12/2002 Diab et al.  
 6,505,059 B1 1/2003 Kollias et al.  
 6,515,273 B2 2/2003 Al-Ali  
 6,519,487 B1 2/2003 Parker  
 6,525,386 B1 2/2003 Mills et al.  
 6,526,300 B1 2/2003 Kiani et al.  
 6,541,756 B2 4/2003 Schulz et al.  
 6,542,764 B1 4/2003 Al-Ali et al.  
 6,580,086 B1 6/2003 Schulz et al.  
 6,584,336 B1 6/2003 Ali et al.  
 6,595,316 B2 7/2003 Cybulski et al.  
 6,597,932 B2 7/2003 Tian et al.  
 6,597,933 B2 7/2003 Kiani et al.  
 6,606,511 B1 8/2003 Ali et al.  
 6,632,181 B2 10/2003 Flaherty et al.  
 6,639,668 B1 10/2003 Trepagnier  
 6,640,116 B2 10/2003 Diab  
 6,643,530 B2 11/2003 Diab et al.  
 6,650,917 B2 11/2003 Diab et al.  
 6,654,624 B2 11/2003 Diab et al.  
 6,658,276 B2 12/2003 Kiani et al.  
 6,661,161 B1 12/2003 Lanzo et al.  
 6,671,531 B2 12/2003 Al-Ali et al.  
 6,678,543 B2 1/2004 Diab et al.  
 6,684,090 B2 1/2004 Ali et al.  
 6,684,091 B2 1/2004 Parker

(56)

## References Cited

## U.S. PATENT DOCUMENTS

6,697,656 B1	2/2004	Al-Ali	7,292,883 B2	11/2007	De Felice et al.
6,697,657 B1	2/2004	Shehada et al.	7,295,866 B2	11/2007	Al-Ali
6,697,658 B2	2/2004	Al-Ali	7,328,053 B1	2/2008	Diab et al.
RE38,476 E	3/2004	Diab et al.	7,332,784 B2	2/2008	Mills et al.
6,699,194 B1	3/2004	Diab et al.	7,340,287 B2	3/2008	Mason et al.
6,714,804 B2	3/2004	Al-Ali et al.	7,341,559 B2	3/2008	Schulz et al.
RE38,492 E	4/2004	Diab et al.	7,343,186 B2	3/2008	Lamego et al.
6,721,582 B2	4/2004	Trepagnier et al.	D566,282 S	4/2008	Al-Ali et al.
6,721,585 B1	4/2004	Parker	7,355,512 B1	4/2008	Al-Ali
6,725,075 B2	4/2004	Al-Ali	7,356,365 B2	4/2008	Schurman
6,728,560 B2	4/2004	Kollias et al.	7,371,981 B2	5/2008	Abdul-Hafiz
6,735,459 B2	5/2004	Parker	7,373,193 B2	5/2008	Al-Ali et al.
6,745,060 B2	6/2004	Diab et al.	7,373,194 B2	5/2008	Weber et al.
6,760,607 B2	7/2004	Al-Ali	7,376,453 B1	5/2008	Diab et al.
6,770,028 B1	8/2004	Ali et al.	7,377,794 B2	5/2008	Al Ali et al.
6,771,994 B2	8/2004	Kiani et al.	7,377,899 B2	5/2008	Weber et al.
6,792,300 B1	9/2004	Diab et al.	7,383,070 B2	6/2008	Diab et al.
6,813,511 B2	11/2004	Diab et al.	7,415,297 B2	8/2008	Al-Ali et al.
6,816,741 B2	11/2004	Diab	7,428,432 B2	9/2008	Ali et al.
6,822,564 B2	11/2004	Al-Ali	7,438,683 B2	10/2008	Al-Ali et al.
6,826,419 B2	11/2004	Diab et al.	7,440,787 B2	10/2008	Diab
6,830,711 B2	12/2004	Mills et al.	7,454,240 B2	11/2008	Diab et al.
6,850,787 B2	2/2005	Weber et al.	7,467,002 B2	12/2008	Weber et al.
6,850,788 B2	2/2005	Al-Ali	7,469,157 B2	12/2008	Diab et al.
6,852,083 B2	2/2005	Caro et al.	7,471,969 B2	12/2008	Diab et al.
6,861,639 B2	3/2005	Al-Ali	7,471,971 B2	12/2008	Diab et al.
6,898,452 B2	5/2005	Al-Ali et al.	7,483,729 B2	1/2009	Al-Ali et al.
6,920,345 B2	7/2005	Al-Ali et al.	7,483,730 B2	1/2009	Diab et al.
6,931,268 B1	8/2005	Kiani-Azarbayjany et al.	7,489,958 B2	2/2009	Diab et al.
6,934,570 B2	8/2005	Kiani et al.	7,496,391 B2	2/2009	Diab et al.
6,939,305 B2	9/2005	Flaherty et al.	7,496,393 B2	2/2009	Diab et al.
6,943,348 B1	9/2005	Coffin, IV	D587,657 S	3/2009	Al-Ali et al.
6,950,687 B2	9/2005	Al-Ali	7,499,741 B2	3/2009	Diab et al.
6,961,598 B2	11/2005	Diab	7,499,835 B2	3/2009	Weber et al.
6,970,792 B1	11/2005	Diab	7,500,950 B2	3/2009	Al-Ali et al.
6,979,812 B2	12/2005	Al-Ali	7,509,154 B2	3/2009	Diab et al.
6,985,764 B2	1/2006	Mason et al.	7,509,494 B2	3/2009	Al-Ali
6,993,371 B2	1/2006	Kiani et al.	7,510,849 B2	3/2009	Schurman et al.
6,996,427 B2	2/2006	Ali et al.	7,526,328 B2	4/2009	Diab et al.
6,999,904 B2	2/2006	Weber et al.	7,530,942 B1	5/2009	Diab
7,003,338 B2	2/2006	Weber et al.	7,530,949 B2	5/2009	Al Ali et al.
7,003,339 B2	2/2006	Diab et al.	7,530,955 B2	5/2009	Diab et al.
7,015,451 B2	3/2006	Dalke et al.	7,563,110 B2	7/2009	Al-Ali et al.
7,024,233 B2	4/2006	Ali et al.	7,596,398 B2	9/2009	Al-Ali et al.
7,027,849 B2	4/2006	Al-Ali	7,618,375 B2	11/2009	Flaherty
7,030,749 B2	4/2006	Al-Ali	D606,659 S	12/2009	Kiani et al.
7,039,449 B2	5/2006	Al-Ali	7,647,083 B2	1/2010	Al-Ali et al.
7,041,060 B2	5/2006	Flaherty et al.	D609,193 S	2/2010	Al-Ali et al.
7,044,918 B2	5/2006	Diab	D614,305 S	4/2010	Al-Ali et al.
7,048,687 B1	5/2006	Reuss et al.	RE41,317 E	5/2010	Parker
7,067,893 B2	6/2006	Mills et al.	7,729,733 B2	6/2010	Al-Ali et al.
7,096,052 B2	8/2006	Mason et al.	7,734,320 B2	6/2010	Al-Ali
7,096,054 B2	8/2006	Abdul-Hafiz et al.	7,761,127 B2	7/2010	Al-Ali et al.
7,132,641 B2	11/2006	Schulz et al.	7,761,128 B2	7/2010	Al-Ali et al.
7,142,901 B2	11/2006	Kiani et al.	7,764,982 B2	7/2010	Dalke et al.
7,149,561 B2	12/2006	Diab	D621,516 S	8/2010	Kiani et al.
7,186,966 B2	3/2007	Al-Ali	7,791,155 B2	9/2010	Diab
7,190,261 B2	3/2007	Al-Ali	7,801,581 B2	9/2010	Diab
7,215,984 B2	5/2007	Diab	7,822,452 B2	10/2010	Schurman et al.
7,215,986 B2	5/2007	Diab	RE41,912 E	11/2010	Parker
7,221,971 B2	5/2007	Diab	7,844,313 B2	11/2010	Kiani et al.
7,225,006 B2	5/2007	Al-Ali et al.	7,844,314 B2	11/2010	Al-Ali
7,225,007 B2	5/2007	Al-Ali	7,844,315 B2	11/2010	Al-Ali
RE39,672 E	6/2007	Shehada et al.	7,865,222 B2	1/2011	Weber et al.
7,239,905 B2	7/2007	Kiani-Azarbayjany et al.	7,873,497 B2	1/2011	Weber et al.
7,245,953 B1	7/2007	Parker	7,880,606 B2	2/2011	Al-Ali
7,254,429 B2	8/2007	Schurman et al.	7,880,626 B2	2/2011	Al-Ali et al.
7,254,431 B2	8/2007	Al-Ali	7,891,355 B2	2/2011	Al-Ali et al.
7,254,433 B2	8/2007	Diab et al.	7,894,868 B2	2/2011	Al-Ali et al.
7,254,434 B2	8/2007	Schulz et al.	7,899,507 B2	3/2011	Al-Ali et al.
7,272,425 B2	9/2007	Al-Ali	7,899,518 B2	3/2011	Trepagnier et al.
7,274,955 B2	9/2007	Kiani et al.	7,904,132 B2	3/2011	Weber et al.
D554,263 S	10/2007	Al-Ali	7,909,772 B2	3/2011	Popov et al.
7,280,858 B2	10/2007	Al-Ali et al.	7,910,875 B2	3/2011	Al-Ali
7,289,835 B2	10/2007	Mansfield et al.	7,919,713 B2	4/2011	Al-Ali et al.
			7,937,128 B2	5/2011	Al-Ali
			7,937,129 B2	5/2011	Mason et al.
			7,937,130 B2	5/2011	Diab et al.
			7,941,199 B2	5/2011	Kiani

(56)

## References Cited

## U.S. PATENT DOCUMENTS

7,951,086 B2	5/2011	Flaherty et al.	8,455,290 B2	6/2013	Siskavich
7,957,780 B2	6/2011	Lamego et al.	8,457,703 B2	6/2013	Al-Ali
7,962,188 B2	6/2011	Kiani et al.	8,457,707 B2	6/2013	Kiani
7,962,190 B1	6/2011	Diab et al.	8,463,349 B2	6/2013	Diab et al.
7,976,472 B2	7/2011	Kiani	8,466,286 B2	6/2013	Bellot et al.
7,988,637 B2	8/2011	Diab	8,471,713 B2	6/2013	Poeze et al.
7,990,382 B2	8/2011	Kiani	8,473,020 B2	6/2013	Kiani et al.
7,991,446 B2	8/2011	Al-Ali et al.	8,483,787 B2	7/2013	Al-Ali et al.
8,000,761 B2	8/2011	Al-Ali	8,489,364 B2	7/2013	Weber et al.
8,008,088 B2	8/2011	Bellott et al.	8,498,684 B2	7/2013	Weber et al.
RE42,753 E	9/2011	Kiani-Azarbayjany et al.	8,504,128 B2	8/2013	Blank et al.
8,019,400 B2	9/2011	Diab et al.	8,509,867 B2	8/2013	Workman et al.
8,028,701 B2	10/2011	Al-Ali et al.	8,515,509 B2	8/2013	Bruinsma et al.
8,029,765 B2	10/2011	Bellott et al.	8,523,781 B2	9/2013	Al-Ali
8,036,727 B2	10/2011	Schurman et al.	8,529,301 B2	9/2013	Al-Ali et al.
8,036,728 B2	10/2011	Diab et al.	8,532,727 B2	9/2013	Ali et al.
8,046,040 B2	10/2011	Ali et al.	8,532,728 B2	9/2013	Diab et al.
8,046,041 B2	10/2011	Diab et al.	D692,145 S	10/2013	Al-Ali et al.
8,046,042 B2	10/2011	Diab et al.	8,547,209 B2	10/2013	Kiani et al.
8,048,040 B2	11/2011	Kiani	8,548,548 B2	10/2013	Al-Ali
8,050,728 B2	11/2011	Al-Ali et al.	8,548,549 B2	10/2013	Schurman et al.
RE43,169 E	2/2012	Parker	8,548,550 B2	10/2013	Al-Ali et al.
8,118,620 B2	2/2012	Al-Ali et al.	8,560,032 B2	10/2013	Al-Ali et al.
8,126,528 B2	2/2012	Diab et al.	8,560,034 B1	10/2013	Diab et al.
8,128,572 B2	3/2012	Diab et al.	8,570,167 B2	10/2013	Al-Ali
8,130,105 B2	3/2012	Al-Ali et al.	8,570,503 B2	10/2013	Vo et al.
8,145,287 B2	3/2012	Diab et al.	8,571,617 B2	10/2013	Reichgott et al.
8,150,487 B2	4/2012	Diab et al.	8,571,618 B1	10/2013	Lamego et al.
8,175,672 B2	5/2012	Parker	8,571,619 B2	10/2013	Al-Ali et al.
8,180,420 B2	5/2012	Diab et al.	8,577,431 B2	11/2013	Lamego et al.
8,182,443 B1	5/2012	Kiani	8,581,732 B2	11/2013	Al-Ali et al.
8,185,180 B2	5/2012	Diab et al.	8,584,345 B2	11/2013	Al-Ali et al.
8,190,223 B2	5/2012	Al-Ali et al.	8,588,880 B2	11/2013	Abdul-Hafiz et al.
8,190,227 B2	5/2012	Diab et al.	8,600,467 B2	12/2013	Al-Ali et al.
8,203,438 B2	6/2012	Kiani et al.	8,606,342 B2	12/2013	Diab
8,203,704 B2	6/2012	Merritt et al.	8,626,255 B2	1/2014	Al-Ali et al.
8,204,566 B2	6/2012	Schurman et al.	8,630,691 B2	1/2014	Lamego et al.
8,219,172 B2	7/2012	Schurman et al.	8,634,889 B2	1/2014	Al-Ali et al.
8,224,411 B2	7/2012	Al-Ali et al.	8,641,631 B2	2/2014	Sierra et al.
8,228,181 B2	7/2012	Al-Ali	8,652,060 B2	2/2014	Al-Ali
8,229,533 B2	7/2012	Diab et al.	8,663,107 B2	3/2014	Kiani
8,233,955 B2	7/2012	Al-Ali et al.	8,666,468 B1	3/2014	Al-Ali
8,244,325 B2	8/2012	Al-Ali et al.	8,667,967 B2	3/2014	Al-Ali et al.
8,255,026 B1	8/2012	Al-Ali	8,670,811 B2	3/2014	O'Reilly
8,255,027 B2	8/2012	Al-Ali et al.	8,670,814 B2	3/2014	Diab et al.
8,255,028 B2	8/2012	Al-Ali et al.	8,676,286 B2	3/2014	Weber et al.
8,260,577 B2	9/2012	Weber et al.	8,682,407 B2	3/2014	Al-Ali
8,265,723 B1	9/2012	McHale et al.	RE44,823 E	4/2014	Parker
8,274,360 B2	9/2012	Sampath et al.	RE44,875 E	4/2014	Kiani et al.
8,280,473 B2	10/2012	Al-Ali	8,690,799 B2	4/2014	Telfort et al.
8,301,217 B2	10/2012	Al-Ali et al.	8,700,112 B2	4/2014	Kiani
8,306,596 B2	11/2012	Schurman et al.	8,702,627 B2	4/2014	Telfort et al.
8,310,336 B2	11/2012	Muhsin et al.	8,706,179 B2	4/2014	Parker
8,315,683 B2	11/2012	Al-Ali et al.	8,712,494 B1	4/2014	MacNeish, III et al.
RE43,860 E	12/2012	Parker	8,715,206 B2	5/2014	Telfort et al.
8,337,403 B2	12/2012	Al-Ali et al.	8,718,735 B2	5/2014	Lamego et al.
8,346,330 B2	1/2013	Lamego	8,718,737 B2	5/2014	Diab et al.
8,353,842 B2	1/2013	Al-Ali et al.	8,718,738 B2	5/2014	Blank et al.
8,355,766 B2	1/2013	MacNeish, III et al.	8,720,249 B2	5/2014	Al-Ali
8,359,080 B2	1/2013	Diab et al.	8,721,541 B2	5/2014	Al-Ali et al.
8,364,223 B2	1/2013	Al-Ali et al.	8,721,542 B2	5/2014	Al-Ali et al.
8,364,226 B2	1/2013	Diab et al.	8,723,677 B1	5/2014	Kiani
8,374,665 B2	2/2013	Lamego	8,740,792 B1	6/2014	Kiani et al.
8,385,995 B2	2/2013	Al-ali et al.	8,754,776 B2	6/2014	Poeze et al.
8,385,996 B2	2/2013	Smith et al.	8,755,535 B2	6/2014	Telfort et al.
8,388,353 B2	3/2013	Kiani et al.	8,755,856 B2	6/2014	Diab et al.
8,399,822 B2	3/2013	Al-Ali	8,755,872 B1	6/2014	Marinow
8,401,602 B2	3/2013	Kiani	8,761,850 B2	6/2014	Lamego
8,405,608 B2	3/2013	Al-Ali et al.	8,764,671 B2	7/2014	Kiani
8,414,499 B2	4/2013	Al-Ali et al.	8,768,423 B2	7/2014	Shakespeare et al.
8,418,524 B2	4/2013	Al-Ali	8,771,204 B2	7/2014	Telfort et al.
8,423,106 B2	4/2013	Lamego et al.	8,777,634 B2	7/2014	Kiani et al.
8,428,967 B2	4/2013	Olsen et al.	8,781,543 B2	7/2014	Diab et al.
8,430,817 B1	4/2013	Al-Ali et al.	8,781,544 B2	7/2014	Al-Ali et al.
8,437,825 B2	5/2013	Dalvi et al.	8,781,549 B2	7/2014	Al-Ali et al.
			8,788,003 B2	7/2014	Schurman et al.
			8,790,268 B2	7/2014	Al-Ali
			8,801,613 B2	8/2014	Al-Ali et al.
			8,821,397 B2	9/2014	Al-Ali et al.

(56)

## References Cited

## U.S. PATENT DOCUMENTS

8,821,415 B2	9/2014	Al-Ali et al.	9,295,421 B2	3/2016	Kiani et al.
8,830,449 B1	9/2014	Lamego et al.	9,307,928 B1	4/2016	Al-Ali et al.
8,831,700 B2	9/2014	Schurman et al.	9,323,894 B2	4/2016	Kiani
8,840,549 B2	9/2014	Al-Ali et al.	D755,392 S	5/2016	Hwang et al.
8,847,740 B2	9/2014	Kiani et al.	9,326,712 B1	5/2016	Kiani
8,849,365 B2	9/2014	Smith et al.	9,333,316 B2	5/2016	Kiani
8,852,094 B2	10/2014	Al-Ali et al.	9,339,220 B2	5/2016	Lamego et al.
8,852,994 B2	10/2014	Wojtczuk et al.	9,341,565 B2	5/2016	Lamego et al.
8,868,147 B2	10/2014	Stippick et al.	9,351,673 B2	5/2016	Diab et al.
8,868,150 B2	10/2014	Al-Ali et al.	9,351,675 B2	5/2016	Al-Ali et al.
8,870,792 B2	10/2014	Al-Ali et al.	9,364,181 B2	6/2016	Kiani et al.
8,886,271 B2	11/2014	Kiani et al.	9,368,671 B2	6/2016	Wojtczuk et al.
8,888,539 B2	11/2014	Al-Ali et al.	9,370,325 B2	6/2016	Al-Ali et al.
8,888,708 B2	11/2014	Diab et al.	9,370,326 B2	6/2016	McHale et al.
8,892,180 B2	11/2014	Weber et al.	9,370,335 B2	6/2016	Al-Ali et al.
8,897,847 B2	11/2014	Al-Ali	9,375,185 B2	6/2016	Ali et al.
8,909,310 B2	12/2014	Lamego et al.	9,386,953 B2	7/2016	Al-Ali
8,911,377 B2	12/2014	Al-Ali	9,386,961 B2	7/2016	Al-Ali et al.
8,912,909 B2	12/2014	Al-Ali et al.	9,392,945 B2	7/2016	Al-Ali et al.
8,920,317 B2	12/2014	Al-Ali et al.	9,397,448 B2	7/2016	Al-Ali et al.
8,921,699 B2	12/2014	Al-Ali et al.	9,408,542 B1	8/2016	Kinast et al.
8,922,382 B2	12/2014	Al-Ali et al.	9,436,645 B2	9/2016	Al-Ali et al.
8,929,964 B2	1/2015	Al-Ali et al.	9,445,759 B1	9/2016	Lamego et al.
8,942,777 B2	1/2015	Diab et al.	9,466,919 B2	10/2016	Kiani et al.
8,948,834 B2	2/2015	Diab et al.	9,474,474 B2	10/2016	Lamego et al.
8,948,835 B2	2/2015	Diab	9,480,422 B2	11/2016	Al-Ali
8,965,471 B2	2/2015	Lamego	9,480,435 B2	11/2016	Olsen
8,983,564 B2	3/2015	Al-Ali	9,492,110 B2	11/2016	Al-Ali et al.
8,989,831 B2	3/2015	Al-Ali et al.	9,510,779 B2	12/2016	Poeze et al.
8,996,085 B2	3/2015	Kiani et al.	9,517,024 B2	12/2016	Kiani et al.
8,998,809 B2	4/2015	Kiani	9,532,722 B2	1/2017	Lamego et al.
9,028,429 B2	5/2015	Telfort et al.	9,538,949 B2	1/2017	Al-Ali et al.
9,037,207 B2	5/2015	Al-Ali et al.	9,538,980 B2	1/2017	Telfort et al.
9,060,721 B2	6/2015	Reichgott et al.	9,549,696 B2	1/2017	Lamego et al.
9,066,666 B2	6/2015	Kiani	9,554,737 B2	1/2017	Schurman et al.
9,066,680 B1	6/2015	Al-Ali et al.	9,560,996 B2	2/2017	Kiani
9,072,474 B2	7/2015	Al-Ali et al.	9,560,998 B2	2/2017	Al-Ali et al.
9,078,560 B2	7/2015	Schurman et al.	9,566,019 B2	2/2017	Al-Ali et al.
9,084,569 B2	7/2015	Weber et al.	9,579,039 B2	2/2017	Jansen et al.
9,095,316 B2	8/2015	Welch et al.	9,591,975 B2	3/2017	Dalvi et al.
9,106,038 B2	8/2015	Telfort et al.	9,622,692 B2	4/2017	Lamego et al.
9,107,625 B2	8/2015	Telfort et al.	9,622,693 B2	4/2017	Diab
9,107,626 B2	8/2015	Al-Ali et al.	D788,312 S	5/2017	Al-Ali et al.
9,113,831 B2	8/2015	Al-Ali	9,636,055 B2	5/2017	Al-Ali et al.
9,113,832 B2	8/2015	Al-Ali	9,636,056 B2	5/2017	Al-Ali
9,119,595 B2	9/2015	Lamego	9,649,054 B2	5/2017	Lamego et al.
9,131,881 B2	9/2015	Diab et al.	9,662,052 B2	5/2017	Al-Ali et al.
9,131,882 B2	9/2015	Al-Ali et al.	9,668,679 B2	6/2017	Schurman et al.
9,131,883 B2	9/2015	Al-Ali	9,668,680 B2	6/2017	Bruinsma et al.
9,131,917 B2	9/2015	Telfort et al.	9,668,703 B2	6/2017	Al-Ali
9,138,180 B1	9/2015	Coverston et al.	9,675,286 B2	6/2017	Diab
9,138,182 B2	9/2015	Al-Ali et al.	9,687,160 B2	6/2017	Kiani
9,138,192 B2	9/2015	Weber et al.	9,693,719 B2	7/2017	Al-Ali et al.
9,142,117 B2	9/2015	Muhsin et al.	9,693,737 B2	7/2017	Al-Ali
9,153,112 B1	10/2015	Kiani et al.	9,697,928 B2	7/2017	Al-Ali et al.
9,153,121 B2	10/2015	Kiani et al.	9,717,425 B2	8/2017	Kiani et al.
9,161,696 B2	10/2015	Al-Ali et al.	9,717,458 B2	8/2017	Lamego et al.
9,161,713 B2	10/2015	Al-Ali et al.	9,724,016 B1	8/2017	Al-Ali et al.
9,167,995 B2	10/2015	Lamego et al.	9,724,024 B2	8/2017	Al-Ali
9,176,141 B2	11/2015	Al-Ali et al.	9,724,025 B1	8/2017	Kiani et al.
9,186,102 B2	11/2015	Bruinsma et al.	9,730,640 B2	8/2017	Diab et al.
9,192,312 B2	11/2015	Al-Ali	9,743,887 B2	8/2017	Al-Ali et al.
9,192,329 B2	11/2015	Al-Ali	9,749,232 B2	8/2017	Sampath et al.
9,192,351 B1	11/2015	Telfort et al.	9,750,442 B2	9/2017	Olsen
9,195,385 B2	11/2015	Al-Ali et al.	9,750,443 B2	9/2017	Smith et al.
9,211,072 B2	12/2015	Kiani	9,750,461 B1	9/2017	Telfort
9,211,095 B1	12/2015	Al-Ali	9,775,545 B2	10/2017	Al-Ali et al.
9,218,454 B2	12/2015	Kiani et al.	9,775,546 B2	10/2017	Diab et al.
9,226,696 B2	1/2016	Kiani	9,775,570 B2	10/2017	Al-Ali
9,241,662 B2	1/2016	Al-Ali et al.	9,778,079 B1	10/2017	Al-Ali et al.
9,245,668 B1	1/2016	Vo et al.	9,782,077 B2	10/2017	Lamego et al.
9,259,185 B2	2/2016	Abdul-Hafiz et al.	9,782,110 B2	10/2017	Kiani
9,267,572 B2	2/2016	Barker et al.	9,787,568 B2	10/2017	Lamego et al.
9,277,880 B2	3/2016	Poeze et al.	9,788,735 B2	10/2017	Al-Ali
9,289,167 B2	3/2016	Diab et al.	9,788,768 B2	10/2017	Al-Ali et al.
			9,795,300 B2	10/2017	Al-Ali
			9,795,310 B2	10/2017	Al-Ali
			9,795,358 B2	10/2017	Telfort et al.
			9,795,739 B2	10/2017	Al-Ali et al.

(56)

## References Cited

## U.S. PATENT DOCUMENTS

9,801,556 B2	10/2017	Kiani	10,213,108 B2	2/2019	Al-Ali
9,801,588 B2	10/2017	Weber et al.	10,219,706 B2	3/2019	Al-Ali
9,808,188 B1	11/2017	Perea et al.	10,219,746 B2	3/2019	McHale et al.
9,814,418 B2	11/2017	Weber et al.	10,226,187 B2	3/2019	Al-Ali et al.
9,820,691 B2	11/2017	Kiani	10,226,576 B2	3/2019	Kiani
9,833,152 B2	12/2017	Kiani et al.	10,231,657 B2	3/2019	Al-Ali et al.
9,833,180 B2	12/2017	Shakespeare et al.	10,231,670 B2	3/2019	Blank et al.
9,839,379 B2	12/2017	Al-Ali et al.	10,231,676 B2	3/2019	Al-Ali et al.
9,839,381 B1	12/2017	Weber et al.	RE47,353 E	4/2019	Kiani et al.
9,847,002 B2	12/2017	Kiani et al.	10,251,585 B2	4/2019	Al-Ali et al.
9,847,749 B2	12/2017	Kiani et al.	10,251,586 B2	4/2019	Lamego
9,848,800 B1	12/2017	Lee et al.	10,255,994 B2	4/2019	Sampath et al.
9,848,806 B2	12/2017	Al-Ali et al.	10,258,265 B1	4/2019	Poeze et al.
9,848,807 B2	12/2017	Lamego	10,258,266 B1	4/2019	Poeze et al.
9,861,298 B2	1/2018	Eckerbom et al.	2006/0161054 A1	7/2006	Reuss et al.
9,861,304 B2	1/2018	Al-Ali et al.	2007/0282478 A1	12/2007	Al-Ali et al.
9,861,305 B1	1/2018	Weber et al.	2009/0247984 A1	10/2009	Lamego et al.
9,867,578 B2	1/2018	Al-Ali et al.	2009/0275813 A1	11/2009	Davis
9,872,623 B2	1/2018	Al-Ali	2009/0275844 A1	11/2009	Al-Ali
9,876,320 B2	1/2018	Coverston et al.	2010/0004518 A1	1/2010	Vo et al.
9,877,650 B2	1/2018	Muhsin et al.	2010/0030040 A1	2/2010	Poeze et al.
9,877,686 B2	1/2018	Al-Ali et al.	2011/0082711 A1	4/2011	Poeze et al.
9,891,079 B2	2/2018	Dalvi	2011/0125060 A1	5/2011	Telfort et al.
9,895,107 B2	2/2018	Al-Ali et al.	2011/0208015 A1	8/2011	Welch et al.
9,913,617 B2	3/2018	Al-Ali et al.	2011/0230733 A1	9/2011	Al-Ali
9,924,893 B2	3/2018	Schurman et al.	2012/0165629 A1	6/2012	Merritt et al.
9,924,897 B1	3/2018	Abdul-Hafiz	2012/0209082 A1	8/2012	Al-Ali
9,936,917 B2	4/2018	Poeze et al.	2012/0209084 A1	8/2012	Olsen et al.
9,943,269 B2	4/2018	Muhsin et al.	2012/0283524 A1	11/2012	Kiani et al.
9,949,676 B2	4/2018	Al-Ali	2013/0023775 A1	1/2013	Lamego et al.
9,955,937 B2	5/2018	Telfort	2013/0041591 A1	2/2013	Lamego
9,965,946 B2	5/2018	Al-Ali	2013/0060147 A1	3/2013	Welch et al.
9,980,667 B2	5/2018	Kiani et al.	2013/0096405 A1	4/2013	Garfio
D820,865 S	6/2018	Muhsin et al.	2013/0096936 A1	4/2013	Sampath et al.
9,986,919 B2	6/2018	Lamego et al.	2013/0243021 A1	9/2013	Siskavich
9,986,952 B2	6/2018	Dalvi et al.	2013/0253334 A1	9/2013	Al-Ali et al.
9,989,560 B2	6/2018	Poeze et al.	2013/0296672 A1	11/2013	O'Neil et al.
9,993,207 B2	6/2018	Al-Ali et al.	2013/0296713 A1	11/2013	Al-Ali et al.
10,007,758 B2	6/2018	Al-Ali et al.	2013/0324808 A1	12/2013	Al-Ali et al.
D822,215 S	7/2018	Al-Ali et al.	2013/0331660 A1	12/2013	Al-Ali et al.
D822,216 S	7/2018	Barker et al.	2014/0012100 A1	1/2014	Al-Ali et al.
10,010,276 B2	7/2018	Al-Ali et al.	2014/0051953 A1	2/2014	Lamego et al.
10,032,002 B2	7/2018	Kiani et al.	2014/0120564 A1	5/2014	Workman et al.
10,039,482 B2	8/2018	Al-Ali et al.	2014/0121482 A1	5/2014	Merritt et al.
10,052,037 B2	8/2018	Kinast et al.	2014/0127137 A1	5/2014	Bellott et al.
10,058,275 B2	8/2018	Al-Ali et al.	2014/0163344 A1	6/2014	Al-Ali
10,064,562 B2	9/2018	Al-Ali	2014/0166076 A1	6/2014	Kiani et al.
10,086,138 B1	10/2018	Novak, Jr.	2014/0171763 A1	6/2014	Diab
10,092,200 B2	10/2018	Al-Ali et al.	2014/0180038 A1	6/2014	Kiani
10,092,249 B2	10/2018	Kiani et al.	2014/0180154 A1	6/2014	Sierra et al.
10,098,550 B2	10/2018	Al-Ali et al.	2014/0180160 A1	6/2014	Brown et al.
10,098,591 B2	10/2018	Al-Ali et al.	2014/0187973 A1	7/2014	Brown et al.
10,098,610 B2	10/2018	Al-Ali et al.	2014/0213864 A1	7/2014	Abdul-Hafiz et al.
D833,624 S	11/2018	DeJong et al.	2014/0275835 A1	9/2014	Lamego et al.
10,123,726 B2	11/2018	Al-Ali et al.	2014/0275871 A1	9/2014	Lamego et al.
10,130,289 B2	11/2018	Al-Ali et al.	2014/0275872 A1	9/2014	Merritt et al.
10,130,291 B2	11/2018	Schurman et al.	2014/0288400 A1	9/2014	Diab et al.
D835,282 S	12/2018	Barker et al.	2014/0316217 A1	10/2014	Purdon et al.
D835,283 S	12/2018	Barker et al.	2014/0316218 A1	10/2014	Purdon et al.
D835,284 S	12/2018	Barker et al.	2014/0316228 A1	10/2014	Blank et al.
D835,285 S	12/2018	Barker et al.	2014/0323825 A1	10/2014	Al-Ali et al.
10,149,616 B2	12/2018	Al-Ali et al.	2014/0323897 A1	10/2014	Brown et al.
10,154,815 B2	12/2018	Al-Ali et al.	2014/0323898 A1	10/2014	Purdon et al.
10,159,412 B2	12/2018	Lamego et al.	2014/0330092 A1	11/2014	Al-Ali et al.
10,188,296 B2	1/2019	Al-Ali et al.	2014/0330098 A1	11/2014	Merritt et al.
10,188,331 B1	1/2019	Al-Ali et al.	2014/0357966 A1	12/2014	Al-Ali et al.
10,188,348 B2	1/2019	Kiani et al.	2015/0005600 A1	1/2015	Blank et al.
RE47,218 E	2/2019	Al-Ali	2015/0011907 A1	1/2015	Purdon et al.
RE47,244 E	2/2019	Kiani et al.	2015/0032029 A1	1/2015	Al-Ali et al.
RE47,249 E	2/2019	Kiani et al.	2015/0038859 A1	2/2015	Dalvi et al.
10,194,847 B2	2/2019	Al-Ali	2015/0080754 A1	3/2015	Purdon et al.
10,194,848 B1	2/2019	Kiani et al.	2015/0087936 A1	3/2015	Al-Ali et al.
10,201,298 B2	2/2019	Al-Ali et al.	2015/0094546 A1	4/2015	Al-Ali
10,205,272 B2	2/2019	Kiani et al.	2015/0099950 A1	4/2015	Al-Ali et al.
10,205,291 B2	2/2019	Scruggs et al.	2015/0101844 A1	4/2015	Al-Ali et al.
			2015/0106121 A1	4/2015	Muhsin et al.
			2015/0112151 A1	4/2015	Muhsin et al.
			2015/0165312 A1	6/2015	Kiani
			2015/0196249 A1	7/2015	Brown et al.

(56)

## References Cited

## U.S. PATENT DOCUMENTS

2015/0216459	A1	8/2015	Al-Ali et al.	2018/0055430	A1	3/2018	Diab et al.
2015/0238722	A1	8/2015	Al-Ali	2018/0064381	A1	3/2018	Shakespeare et al.
2015/0245773	A1	9/2015	Lamego et al.	2018/0069776	A1	3/2018	Lamego et al.
2015/0245794	A1	9/2015	Al-Ali	2018/0070867	A1	3/2018	Smith et al.
2015/0257689	A1	9/2015	Al-Ali et al.	2018/0082767	A1	3/2018	Al-Ali et al.
2015/0272514	A1	10/2015	Kiani et al.	2018/0085068	A1	3/2018	Telfort
2015/0351697	A1	12/2015	Weber et al.	2018/0087937	A1	3/2018	Al-Ali et al.
2015/0359429	A1	12/2015	Al-Ali et al.	2018/0103874	A1	4/2018	Lee et al.
2015/0366507	A1	12/2015	Blank	2018/0103905	A1	4/2018	Kiani
2016/0029932	A1	2/2016	Al-Ali	2018/0110478	A1	4/2018	Al-Ali
2016/0058347	A1	3/2016	Reichgott et al.	2018/0116575	A1	5/2018	Perea et al.
2016/0066824	A1	3/2016	Al-Ali et al.	2018/0125368	A1	5/2018	Lamego et al.
2016/0081552	A1	3/2016	Wojtczuk et al.	2018/0125430	A1	5/2018	Al-Ali et al.
2016/0095543	A1	4/2016	Telfort et al.	2018/0125445	A1	5/2018	Telfort et al.
2016/0095548	A1	4/2016	Al-Ali et al.	2018/0130325	A1	5/2018	Kiani et al.
2016/0103598	A1	4/2016	Al-Ali et al.	2018/0132769	A1	5/2018	Weber et al.
2016/0166182	A1	6/2016	Al-Ali et al.	2018/0132770	A1	5/2018	Lamego
2016/0166183	A1	6/2016	Poeze et al.	2018/0146901	A1	5/2018	Al-Ali et al.
2016/0196388	A1	7/2016	Lamego	2018/0146902	A1	5/2018	Kiani et al.
2016/0197436	A1	7/2016	Barker et al.	2018/0153442	A1	6/2018	Eckerbom et al.
2016/0213281	A1	7/2016	Eckerbom et al.	2018/0153446	A1	6/2018	Kiani
2016/0228043	A1	8/2016	O'Neil et al.	2018/0153447	A1	6/2018	Al-Ali et al.
2016/0233632	A1	8/2016	Scruggs et al.	2018/0153448	A1	6/2018	Weber et al.
2016/0234944	A1	8/2016	Schmidt et al.	2018/0161499	A1	6/2018	Al-Ali et al.
2016/0270735	A1	9/2016	Diab et al.	2018/0168491	A1	6/2018	Al-Ali et al.
2016/0283665	A1	9/2016	Sampath et al.	2018/0174679	A1	6/2018	Sampath et al.
2016/0287090	A1	10/2016	Al-Ali et al.	2018/0174680	A1	6/2018	Sampath et al.
2016/0287786	A1	10/2016	Kiani	2018/0182484	A1	6/2018	Sampath et al.
2016/0296169	A1	10/2016	McHale et al.	2018/0184917	A1	7/2018	Kiani
2016/0310052	A1	10/2016	Al-Ali et al.	2018/0192924	A1	7/2018	Al-Ali
2016/0314260	A1	10/2016	Kiani	2018/0192953	A1	7/2018	Shreim et al.
2016/0324488	A1	11/2016	Olsen	2018/0192955	A1	7/2018	Al-Ali et al.
2016/0327984	A1	11/2016	Al-Ali et al.	2018/0199871	A1	7/2018	Pauley et al.
2016/0331332	A1	11/2016	Al-Ali	2018/0206795	A1	7/2018	Al-Ali
2016/0367173	A1	12/2016	Dalvi et al.	2018/0206815	A1	7/2018	Telfort
2017/0000394	A1	1/2017	Al-Ali et al.	2018/0213583	A1	7/2018	Al-Ali
2017/0007134	A1	1/2017	Al-Ali et al.	2018/0214031	A1	8/2018	Kiani et al.
2017/0007198	A1	1/2017	Al-Ali et al.	2018/0214090	A1	8/2018	Al-Ali et al.
2017/0014083	A1	1/2017	Diab et al.	2018/0218792	A1	8/2018	Muhsin et al.
2017/0014084	A1	1/2017	Al-Ali et al.	2018/0225960	A1	8/2018	Al-Ali et al.
2017/0024748	A1	1/2017	Haider	2018/0238718	A1	8/2018	Dalvi
2017/0042488	A1	2/2017	Muhsin	2018/0242853	A1	8/2018	Al-Ali
2017/0055851	A1	3/2017	Al-Ali	2018/0242921	A1	8/2018	Muhsin et al.
2017/0055882	A1	3/2017	Al-Ali et al.	2018/0242923	A1	8/2018	Al-Ali et al.
2017/0055887	A1	3/2017	Al-Ali	2018/0242924	A1	8/2018	Barker et al.
2017/0055896	A1	3/2017	Al-Ali et al.	2018/0242926	A1	8/2018	Muhsin et al.
2017/0079594	A1	3/2017	Telfort et al.	2018/0247353	A1	8/2018	Al-Ali et al.
2017/0086723	A1	3/2017	Al-Ali et al.	2018/0247712	A1	8/2018	Muhsin et al.
2017/0143281	A1	5/2017	Olsen	2018/0249933	A1	9/2018	Schurman et al.
2017/0147774	A1	5/2017	Kiani	2018/0253947	A1	9/2018	Muhsin et al.
2017/0156620	A1	6/2017	Al-Ali et al.	2018/0256087	A1	9/2018	Al-Ali et al.
2017/0173632	A1	6/2017	Al-Ali	2018/0256113	A1	9/2018	Weber et al.
2017/0187146	A1	6/2017	Kiani et al.	2018/0285094	A1	10/2018	Housel et al.
2017/0188919	A1	7/2017	Al-Ali et al.	2018/0289325	A1	10/2018	Poeze et al.
2017/0196464	A1	7/2017	Jansen et al.	2018/0289337	A1	10/2018	Al-Ali et al.
2017/0196470	A1	7/2017	Lamego et al.	2018/0296161	A1	10/2018	Shreim et al.
2017/0224262	A1	8/2017	Al-Ali	2018/0300919	A1	10/2018	Muhsin et al.
2017/0228516	A1	8/2017	Sampath et al.	2018/0310822	A1	11/2018	Indorf et al.
2017/0245790	A1	8/2017	Al-Ali et al.	2018/0310823	A1	11/2018	Al-Ali et al.
2017/0251974	A1	9/2017	Shreim et al.	2018/0317826	A1	11/2018	Muhsin
2017/0251975	A1	9/2017	Shreim et al.	2018/0317841	A1	11/2018	Novak, Jr.
2017/0258403	A1	9/2017	Abdul-Hafiz et al.	2018/0333055	A1	11/2018	Lamego et al.
2017/0311851	A1	11/2017	Schurman et al.	2018/0333087	A1	11/2018	Al-Ali
2017/0311891	A1	11/2017	Kiani et al.	2019/0000317	A1	1/2019	Muhsin et al.
2017/0325728	A1	11/2017	Al-Ali et al.	2019/0000362	A1	1/2019	Kiani et al.
2017/0332976	A1	11/2017	Al-Ali et al.	2019/0015023	A1	1/2019	Monfre
2017/0340293	A1	11/2017	Al-Ali et al.	2019/0021638	A1	1/2019	Al-Ali et al.
2017/0360310	A1	12/2017	Kiani et al.	2019/0029574	A1	1/2019	Schurman et al.
2017/0367632	A1	12/2017	Al-Ali et al.	2019/0029578	A1	1/2019	Al-Ali et al.
2018/0008146	A1	1/2018	Al-Ali et al.	2019/0038143	A1	2/2019	Al-Ali
2018/0013562	A1	1/2018	Haider et al.	2019/0058280	A1	2/2019	Al-Ali et al.
2018/0014752	A1	1/2018	Al-Ali et al.	2019/0058281	A1	2/2019	Al-Ali et al.
2018/0028124	A1	2/2018	Al-Ali et al.	2019/0069813	A1	3/2019	Al-Ali
2018/0055385	A1	3/2018	Al-Ali	2019/0069814	A1	3/2019	Al-Ali
2018/0055390	A1	3/2018	Kiani et al.	2019/0076028	A1	3/2019	Al-Ali et al.
				2019/0082979	A1	3/2019	Al-Ali et al.
				2019/0090748	A1	3/2019	Al-Ali
				2019/0090760	A1	3/2019	Kinast et al.
				2019/0090764	A1	3/2019	Al-Ali

(56)

**References Cited**

U.S. PATENT DOCUMENTS

2019/0104973	A1	4/2019	Poeze et al.
2019/0110719	A1	4/2019	Poeze et al.
2019/0117070	A1	4/2019	Muhsin et al.
2019/0117139	A1	4/2019	Al-Ali et al.
2019/0117140	A1	4/2019	Al-Ali et al.
2019/0117141	A1	4/2019	Al-Ali
2019/0117930	A1	4/2019	Al-Ali
2019/0122763	A1	4/2019	Sampath et al.



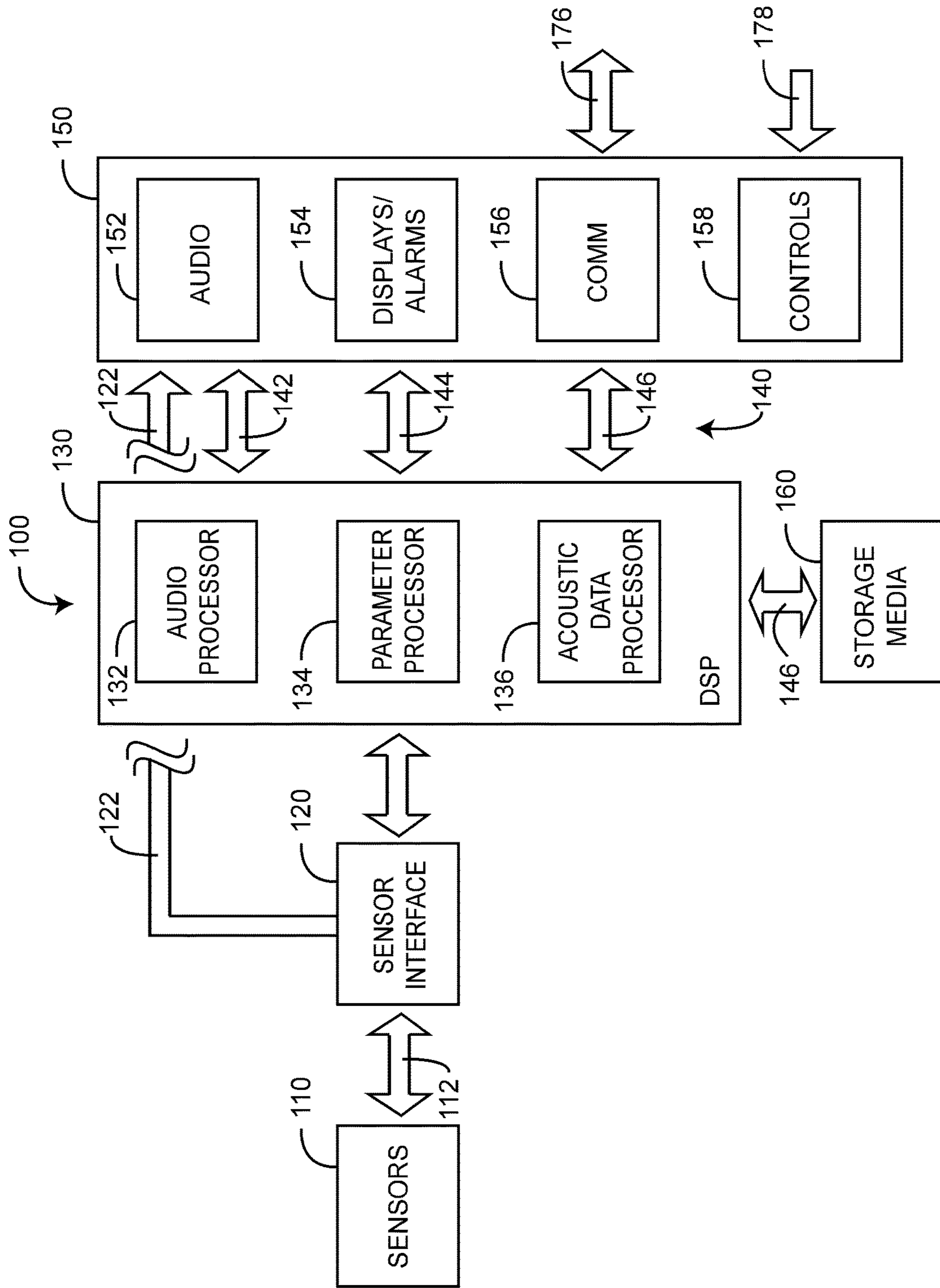

FIG. 1

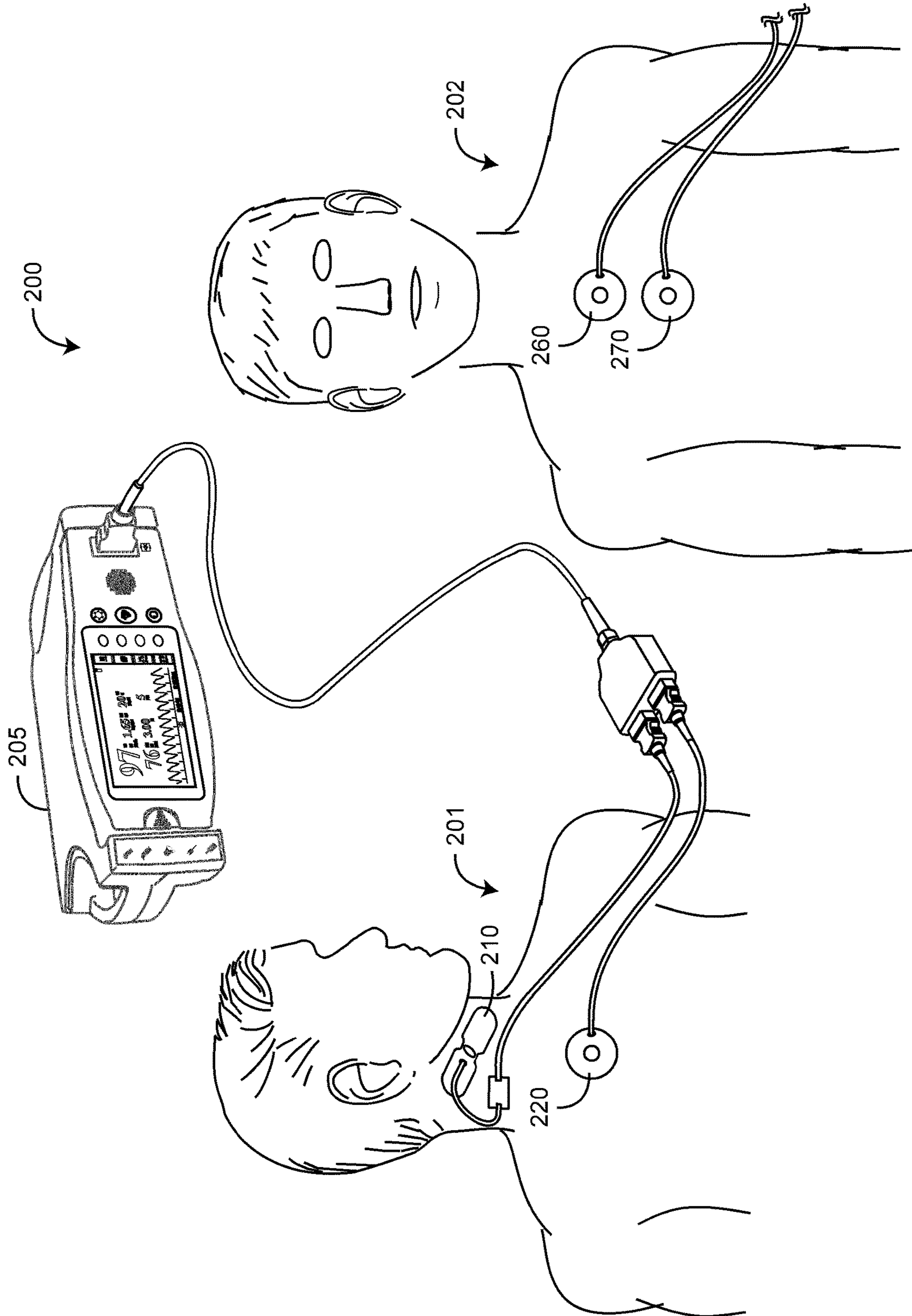

FIG. 2B

FIG. 2A

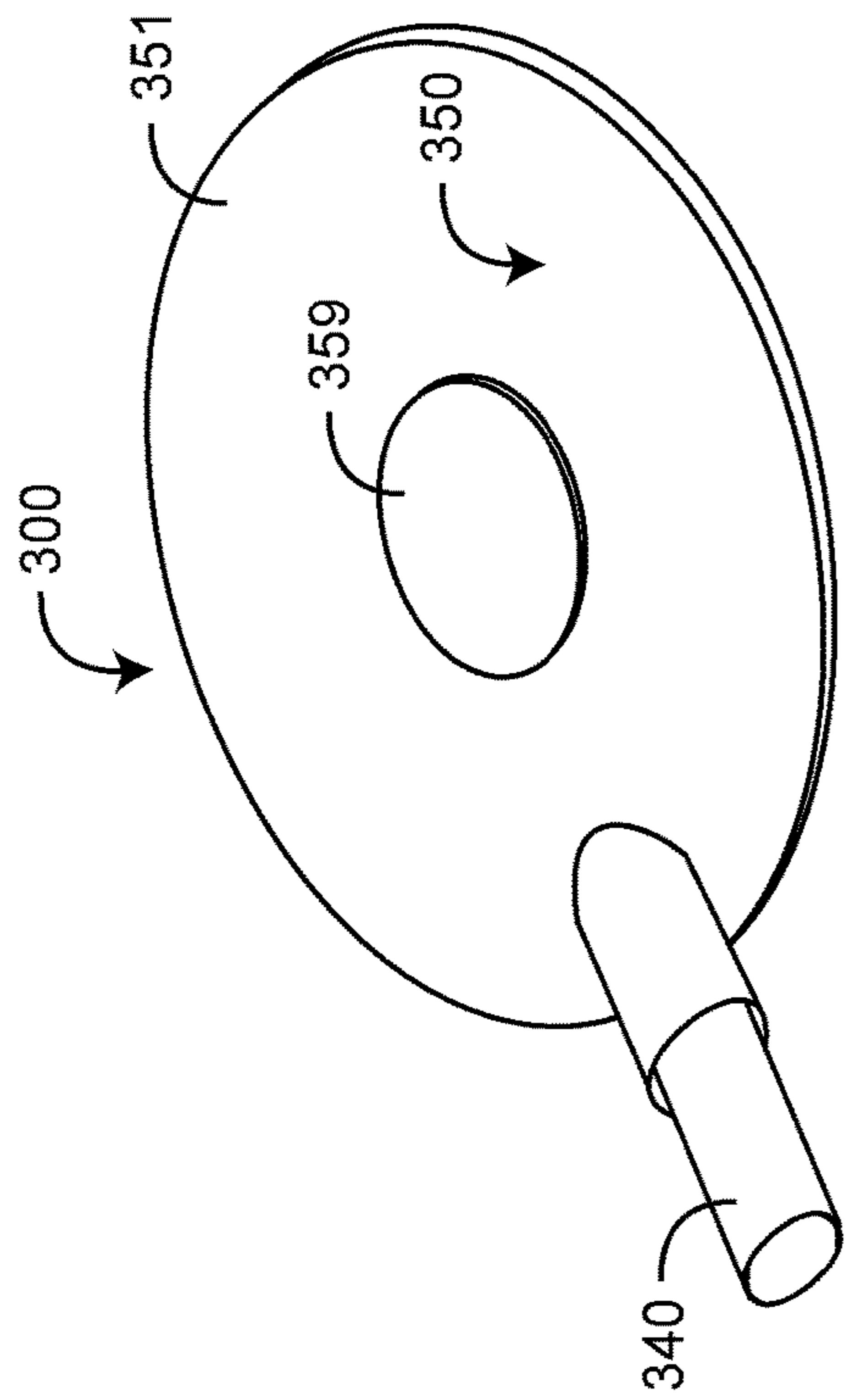

FIG. 3A

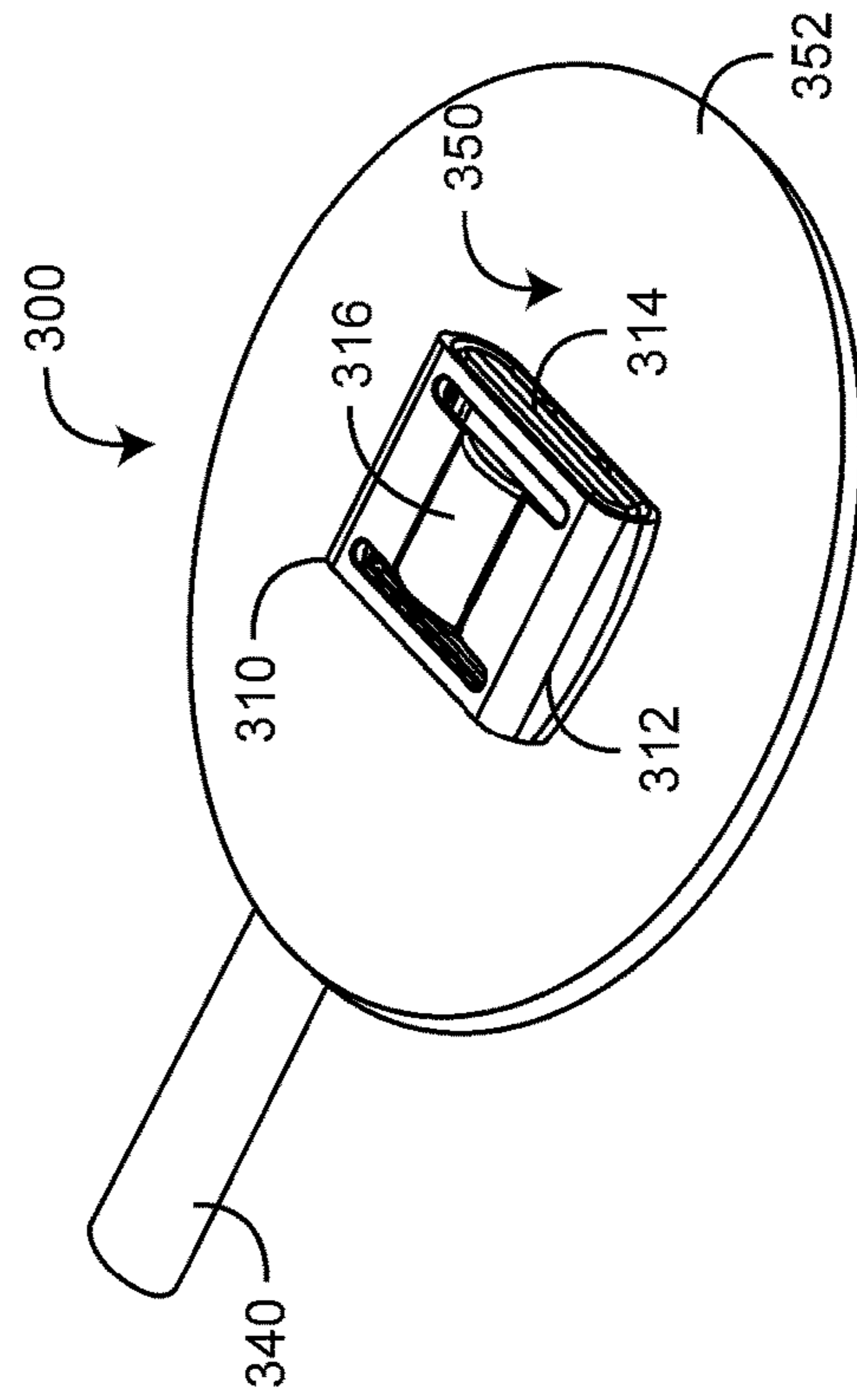

FIG. 3B

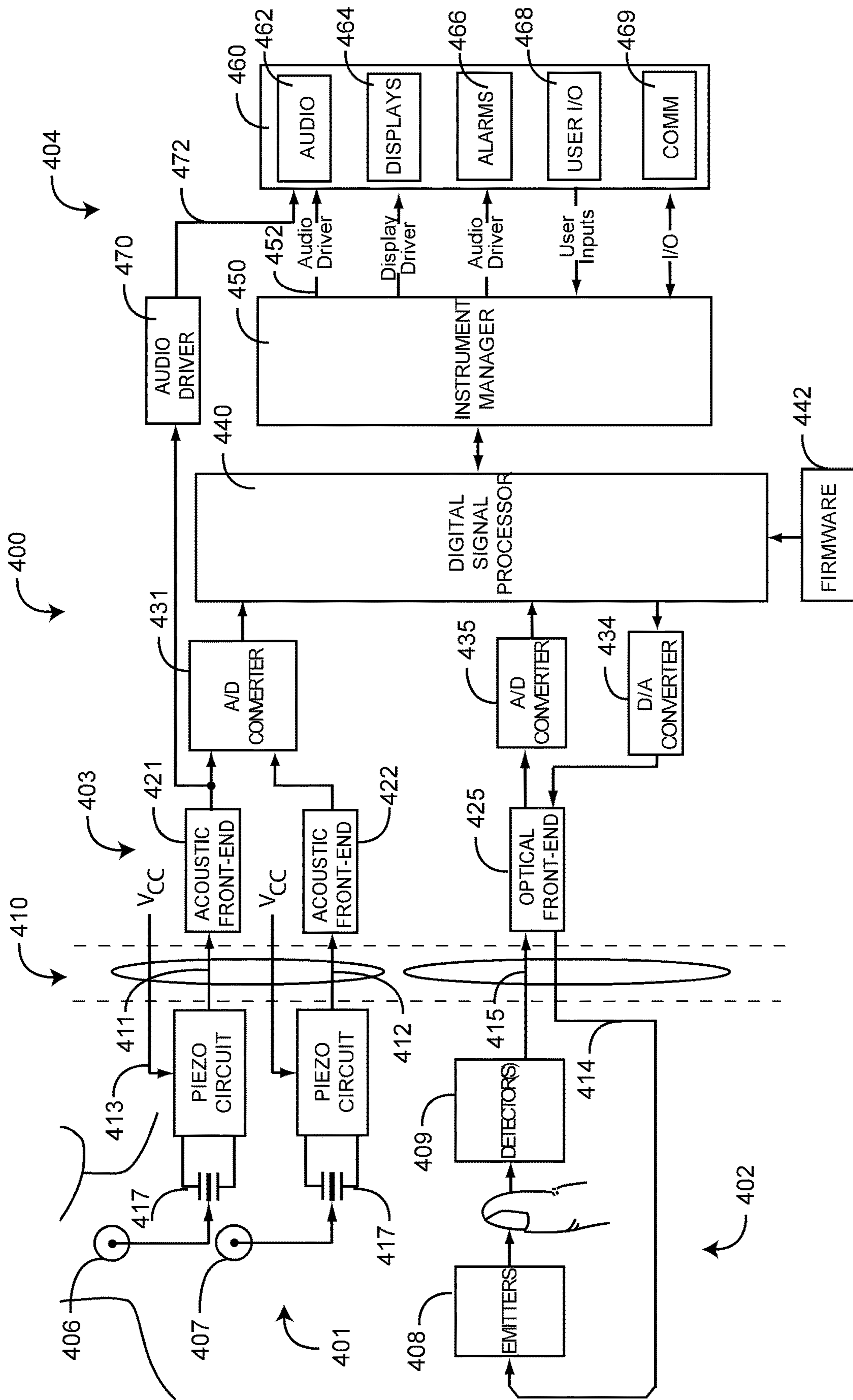

FIG. 4

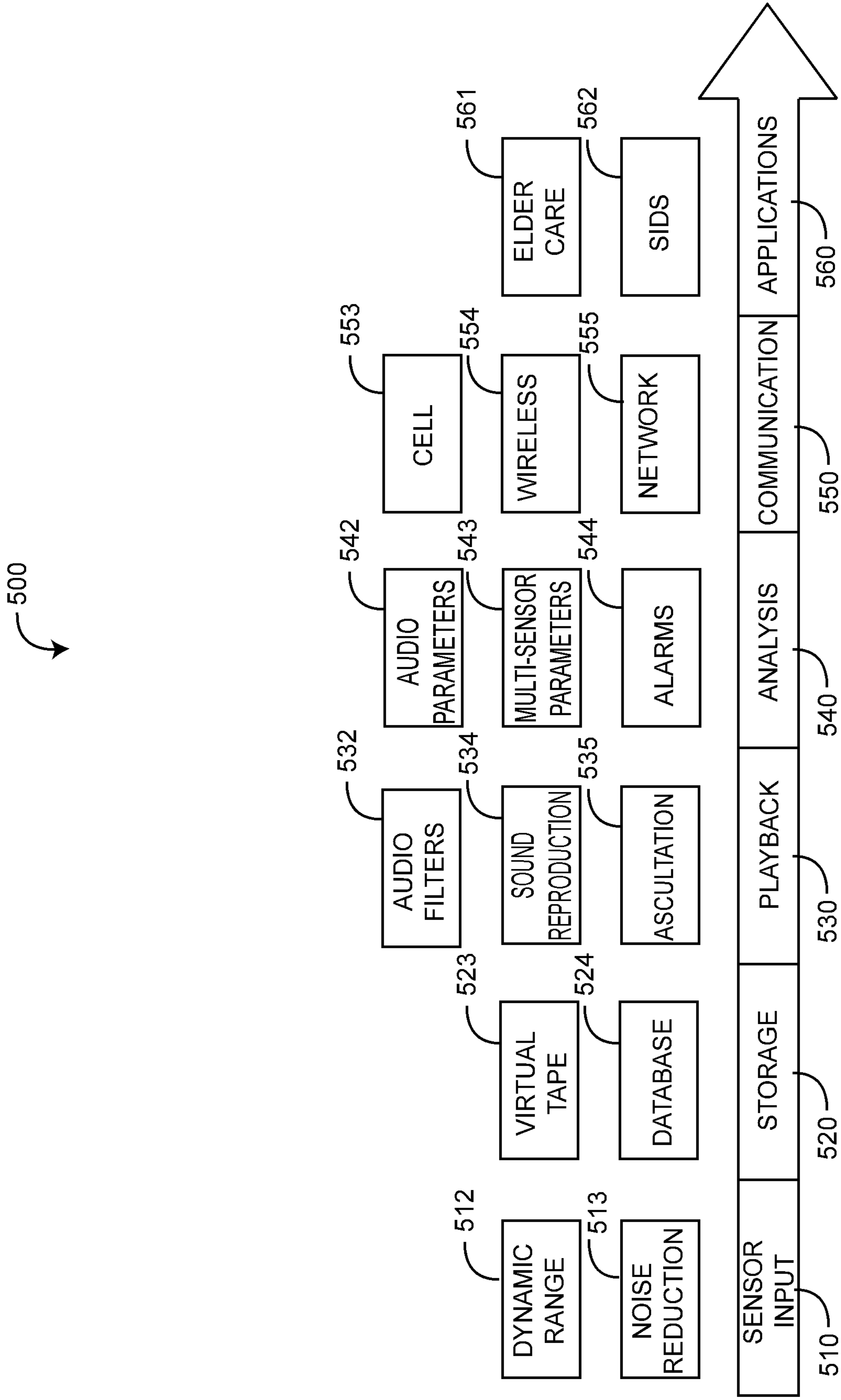

FIG. 5

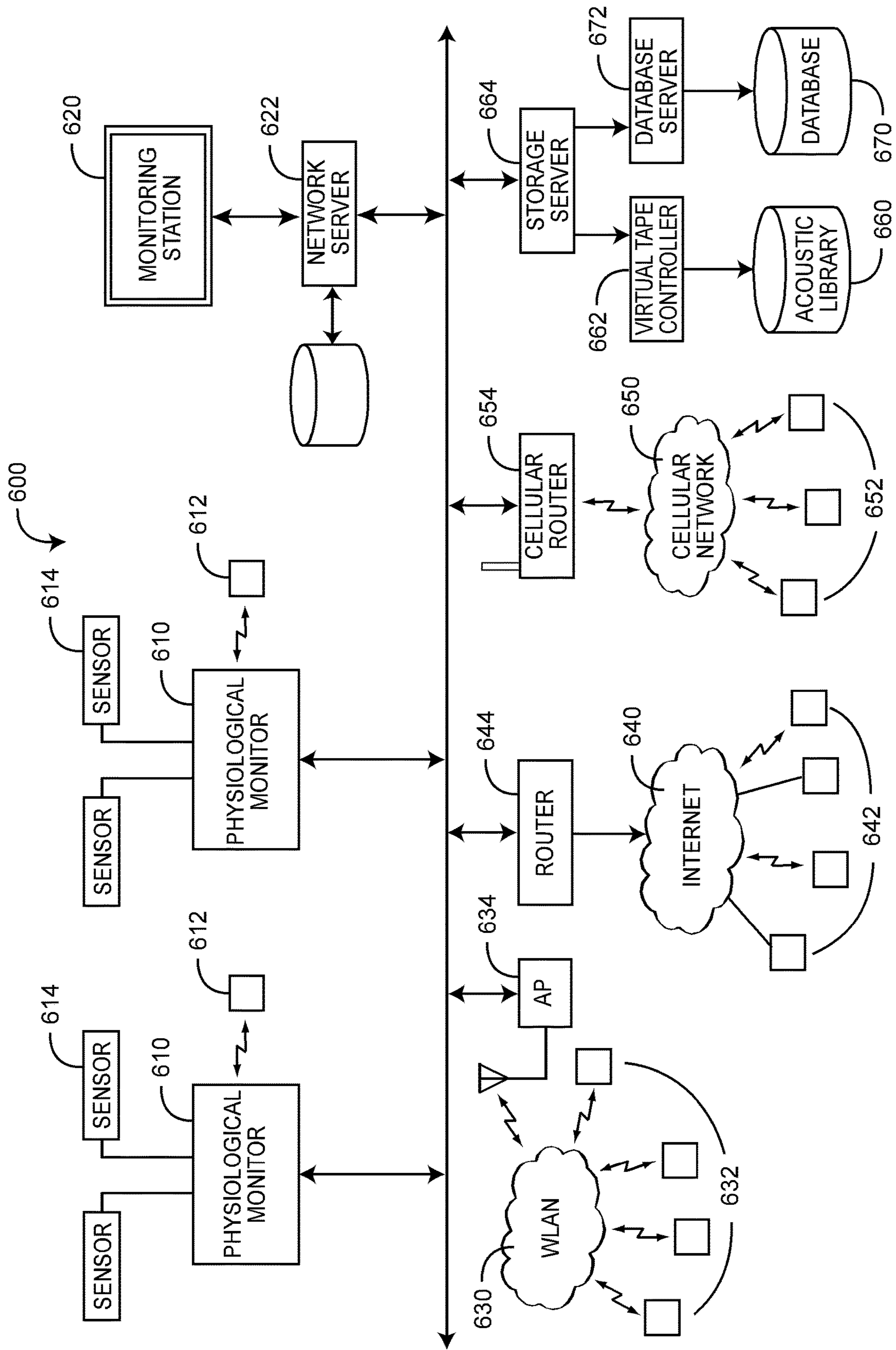

FIG. 6

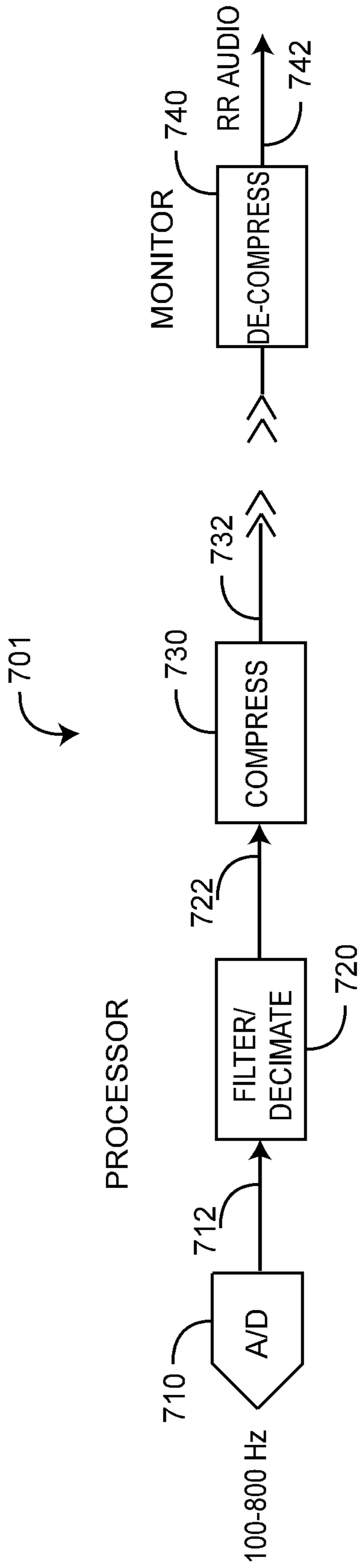

FIG. 7A

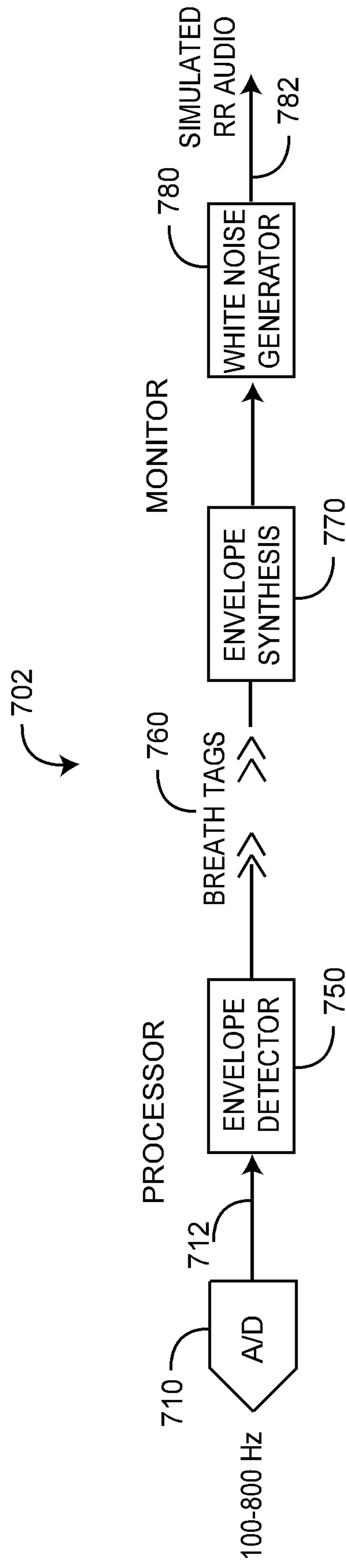

FIG. 7B

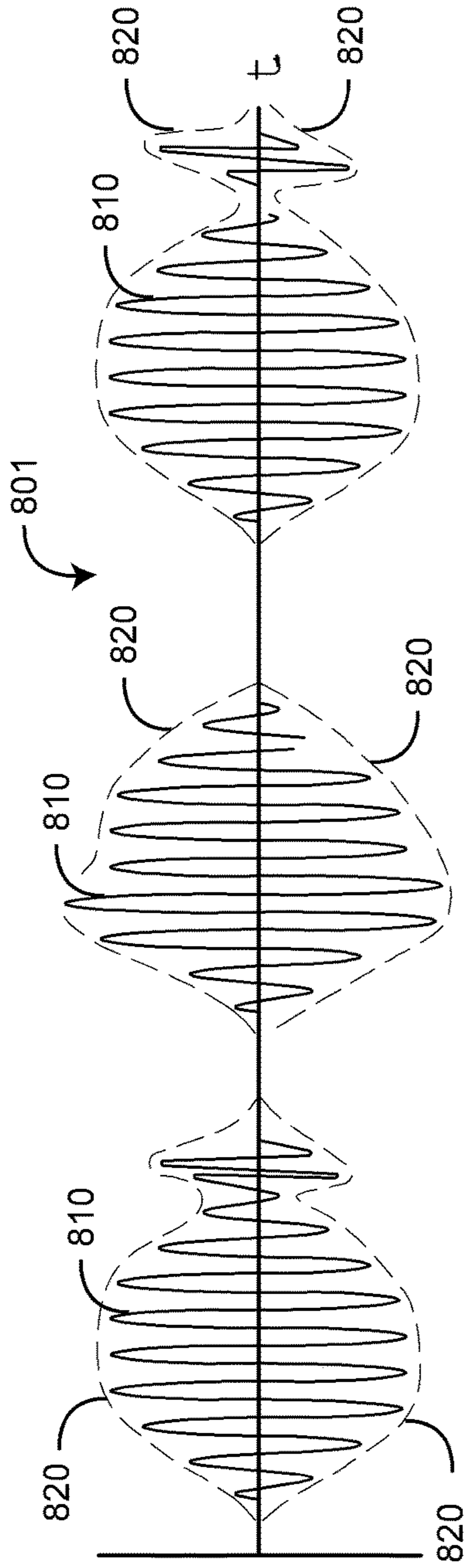

FIG. 8A

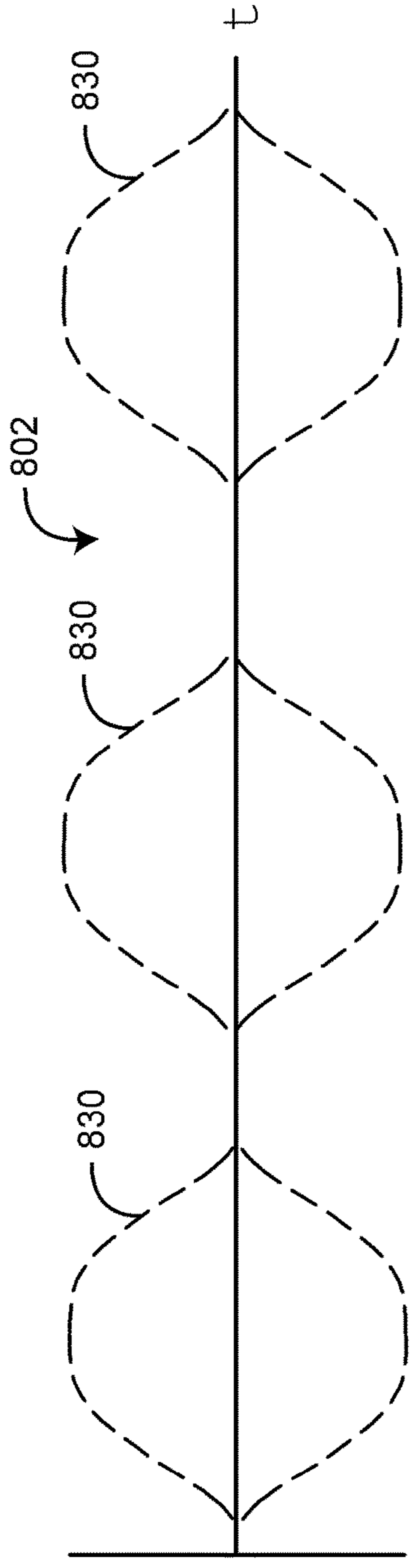

FIG. 8B

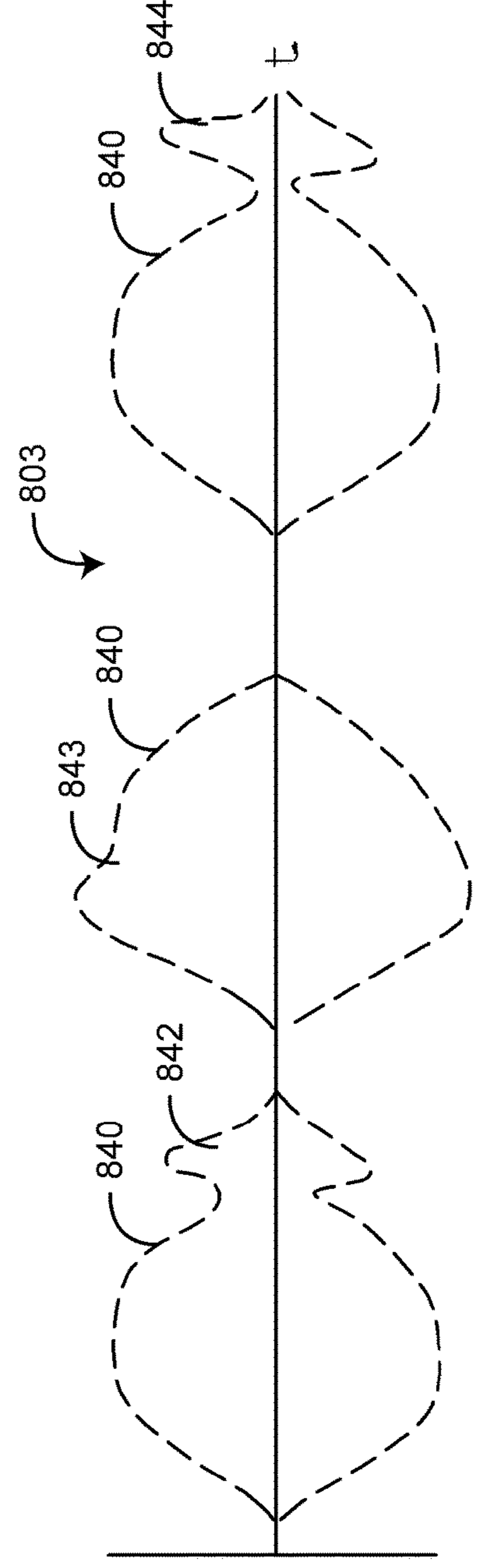

FIG. 8C



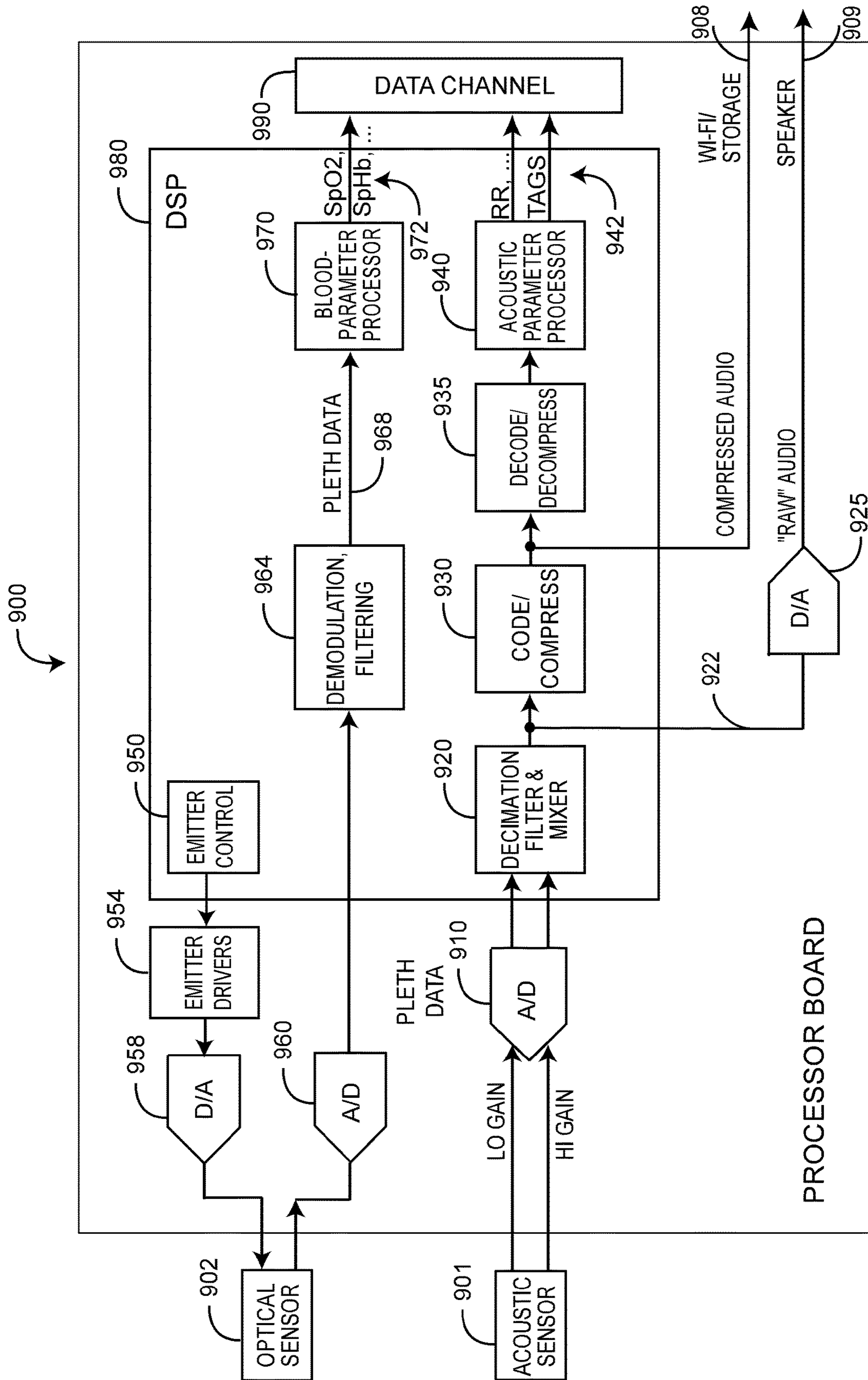

FIG. 9

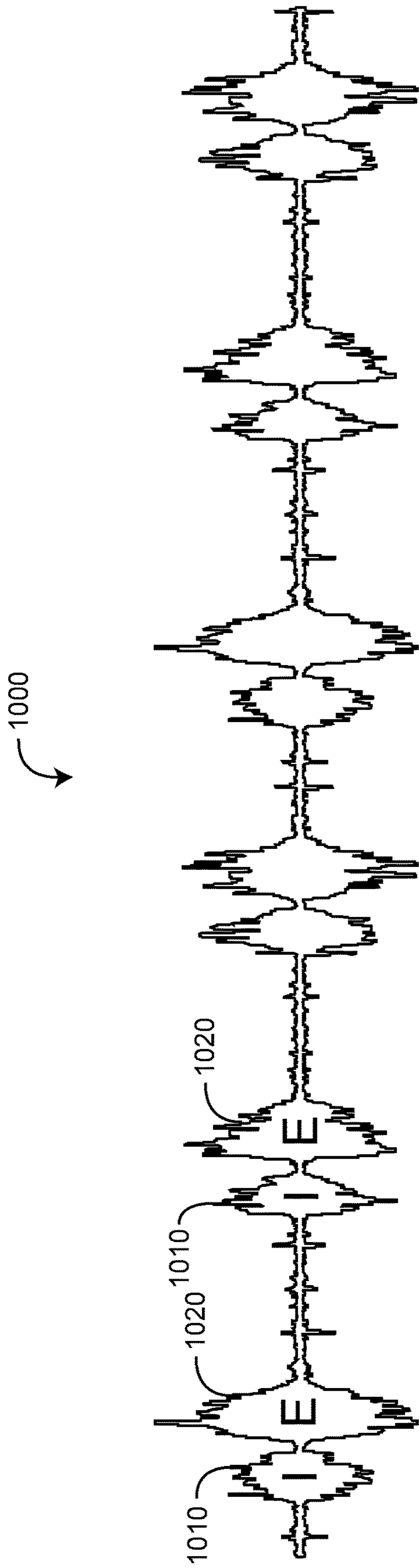

FIG. 10A

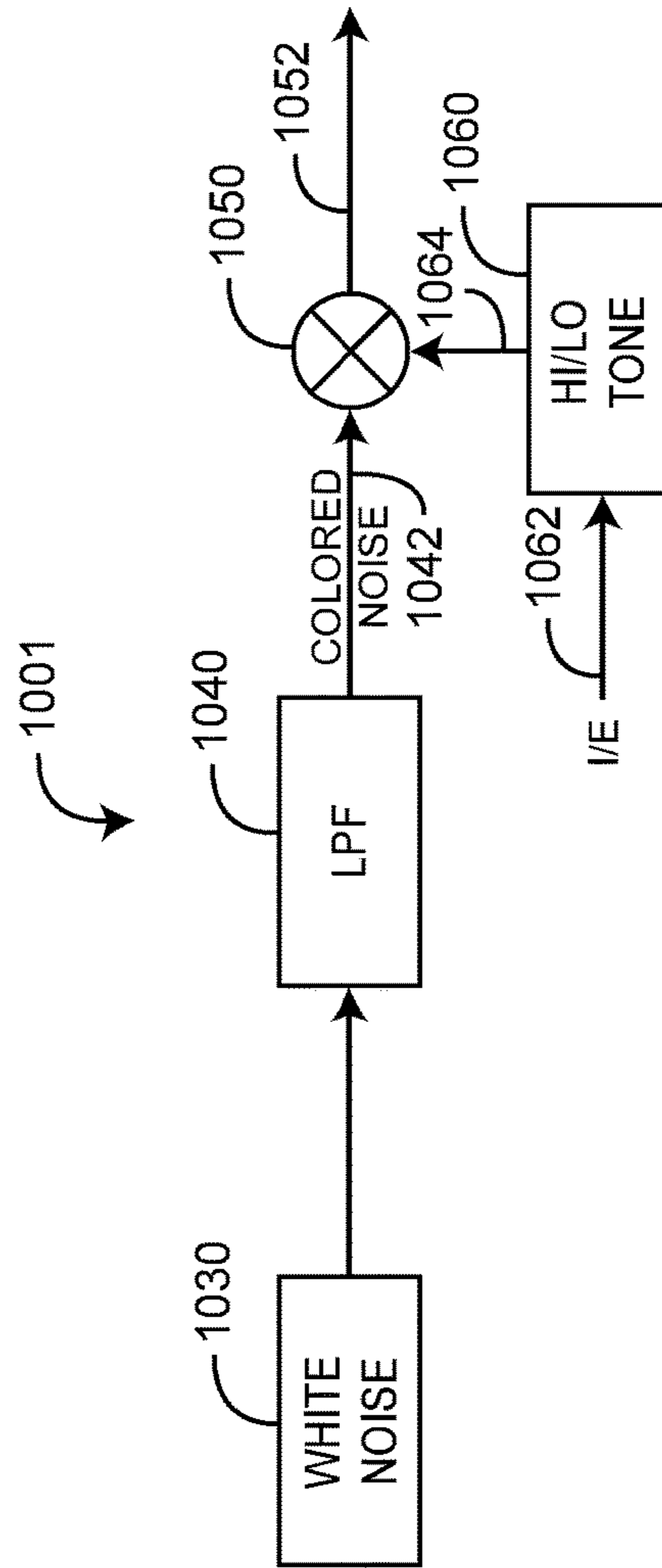

FIG. 10B

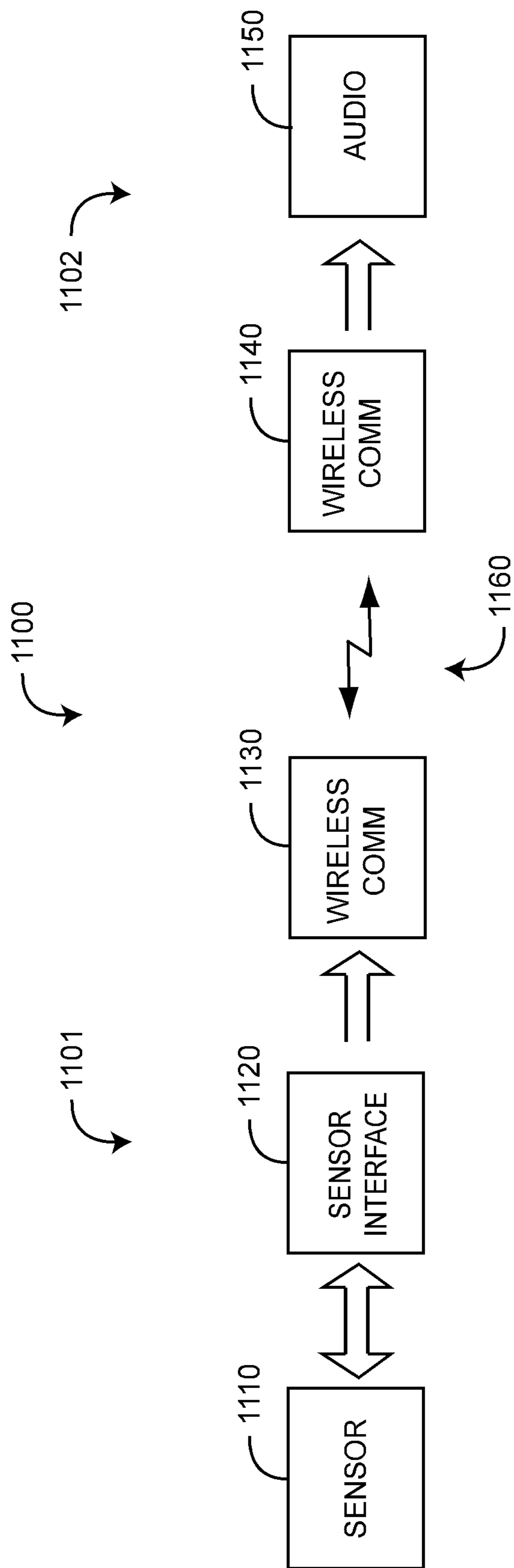

FIG. 11

## PHYSIOLOGICAL ACOUSTIC MONITORING SYSTEM

This application is a continuation of U.S. patent application Ser. No. 15/184,951, filed Jun. 16, 2016, titled PHYSIOLOGICAL ACOUSTIC MONITORING SYSTEM, which is a continuation of U.S. patent application Ser. No. 14/522,474, filed Oct. 23, 2014, now U.S. Pat. No. 9,370,335, titled PHYSIOLOGICAL ACOUSTIC MONITORING SYSTEM, which is a continuation of U.S. patent application Ser. No. 13/650,775, filed Oct. 12, 2012, now U.S. Pat. No. 8,870,792, titled PHYSIOLOGICAL ACOUSTIC MONITORING SYSTEM, which claims the benefit of priority under 35 U.S.C. § 119(e) of U.S. Provisional Patent Application No. 61/547,007, filed Oct. 13, 2011, titled Physiological Acoustic Monitoring System, and is a continuation-in-part of U.S. patent application Ser. No. 12/905,036, filed Oct. 14, 2010, now U.S. Pat. No. 8,821,415, titled Physiological Acoustic Monitoring System, which claims the benefit of priority under 35 U.S.C. § 119(e) of U.S. Provisional Patent Application No. 61/252,099, filed Oct. 15, 2009, and U.S. Provisional Patent Application No. 61/391,098, filed Oct. 8, 2010, the disclosures of which are hereby incorporated in their entirety by reference herein. Additionally, this application relates to the following U.S. patent applications, the disclosures of which are incorporated in their entirety by reference herein:

App. No.	Filing Date	Title
60/893,853	Mar. 8, 2007	MULTI-PARAMETER PHYSIOLOGICAL MONITOR
60/893,850	Mar. 8, 2007	BACKWARD COMPATIBLE PHYSIOLOGICAL SENSOR WITH INFORMATION ELEMENT
60/893,858	Mar. 8, 2007	MULTI-PARAMETER SENSOR FOR PHYSIOLOGICAL MONITORING
60/893,856	Mar. 8, 2007	PHYSIOLOGICAL MONITOR WITH FAST GAIN ADJUST DATA ACQUISITION
12/044,883	Mar. 8, 2008	SYSTEMS AND METHODS FOR DETERMINING A PHYSIOLOGICAL CONDITION USING AN ACOUSTIC MONITOR
61/252,083	Oct. 15, 2009	DISPLAYING PHYSIOLOGICAL INFORMATION
12/904,823	Oct. 14, 2010	BIDIRECTIONAL PHYSIOLOGICAL INFORMATION DISPLAY
61/141,584	Dec. 30, 2008	ACOUSTIC SENSOR ASSEMBLY
61/252,076	Oct. 15, 2009	ACOUSTIC SENSOR ASSEMBLY
12/643,939	Dec. 21, 2009	ACOUSTIC SENSOR ASSEMBLY
61/313,645	Mar. 12, 2010	ACOUSTIC RESPIRATORY MONITORING SENSOR HAVING MULTIPLE SENSING ELEMENTS
12/904,890	Oct. 14, 2010	ACOUSTIC RESPIRATORY MONITORING SENSOR HAVING MULTIPLE SENSING ELEMENTS
12/904,931	Oct. 14, 2010	ACOUSTIC RESPIRATORY MONITORING SENSOR HAVING MULTIPLE SENSING ELEMENTS
12/904,938	Oct. 14, 2010	ACOUSTIC RESPIRATORY MONITORING SENSOR HAVING MULTIPLE SENSING ELEMENTS
12/904,907	Oct. 14, 2010	ACOUSTIC PATIENT SENSOR
12/904,789	Oct. 14, 2010	ACOUSTIC RESPIRATORY MONITORING SYSTEMS AND METHODS
61/252,062	Oct. 15, 2009	PULSE OXIMETRY SYSTEM WITH LOW NOISE CABLE HUB
61/265,730	Dec. 1, 2009	PULSE OXIMETRY SYSTEM WITH ACOUSTIC SENSOR
12/904,775	Oct. 14, 2010	PULSE OXIMETRY SYSTEM WITH LOW NOISE CABLE HUB
12/905,036	Oct. 14, 2010	PHYSIOLOGICAL ACOUSTIC MONITORING SYSTEM
61/331,087	May 4, 2010	ACOUSTIC RESPIRATION DISPLAY
14/473,831	Aug. 29, 2014	PHYSIOLOGICAL ACOUSTIC MONITORING SYSTEM

Many of the embodiments described herein are compatible with embodiments described in the above related applications. Moreover, some or all of the features described herein can be used or otherwise combined with many of the features described in the applications listed above.

### BACKGROUND OF THE INVENTION

The “piezoelectric effect” is the appearance of an electric potential and current across certain faces of a crystal when it is subjected to mechanical stresses. Due to their capacity to convert mechanical deformation into an electric voltage, piezoelectric crystals have been broadly used in devices such as transducers, strain gauges and microphones. However, before the crystals can be used in many of these applications they must be rendered into a form which suits the requirements of the application. In many applications, especially those involving the conversion of acoustic waves into a corresponding electric signal, piezoelectric membranes have been used.

Piezoelectric membranes are typically manufactured from polyvinylidene fluoride plastic film. The film is endowed with piezoelectric properties by stretching the plastic while it is placed under a high-poling voltage. By stretching the film, the film is polarized and the molecular structure of the plastic aligned. A thin layer of conductive metal (typically

nickel-copper) is deposited on each side of the film to form electrode coatings to which connectors can be attached.

Piezoelectric membranes have a number of attributes that make them interesting for use in sound detection, including: a wide frequency range of between 0.001 Hz to 1 GHz; a low acoustical impedance close to water and human tissue; a high dielectric strength; a good mechanical strength; and piezoelectric membranes are moisture resistant and inert to many chemicals.

Due in large part to the above attributes, piezoelectric membranes are particularly suited for the capture of acoustic waves and the conversion thereof into electric signals and, accordingly, have found application in the detection of body sounds. However, there is still a need for a reliable acoustic sensor, particularly one suited for measuring bodily sounds in noisy environments.

#### SUMMARY OF THE INVENTION

An aspect of a physiological acoustic monitoring system receives physiological data from an acoustic sensor, down-samples the data to generate raw audio of breathing sounds and compresses the raw audio. The acoustic monitoring system has an acoustic sensor signal responsive to tracheal sounds in a person. An A/D converter is responsive to the sensor signal so as to generate breathing sound data. A decimation filter and mixer down-samples the breathing sound data to raw audio data. A coder/compressor generates compressed audio data from the raw audio data. A decoder/decompressor decodes and decompresses the compressed audio data into decompressed audio data. The decompressed audio data is utilized to generate respiration-related parameters in real-time. The compressed audio data is stored and retrieved so as to generate respiration-related parameters in non-real-time. The real-time and non-real-time parameters are compared to verify matching results across multiple monitors.

Another aspect of a physiological acoustic monitoring system inputs an acoustic sensor signal responsive to tracheal sounds of a person and generates breath tags and a respiration rate. The breath tags represent the acoustic envelope of the tracheal sound, and the respiration rate represents the inverse period of the acoustic envelope. The breath tags and respiration rate have a sufficiently low bandwidth to share a data channel with other physiological parameters. In an embodiment, the acoustic monitor has an acoustic sensor input and an A/D converter that digitizes the sensor input and outputs a digitized sensor signal. A decimation filter and mixer reduces the data rate of the digitized sensor signal and outputs a digitized raw audio. An acoustic parameter processor generates a respiration rate and breath tags in response to the digitized raw audio.

In various embodiments, the acoustic monitoring system has a coder/compressor that compresses the digitized raw audio to generate compressed audio data, which is stored and retrieved so as to generate respiration-related parameters in non-real-time. A decoder/decompressor decompresses the compressed audio data for the acoustic parameter processor. A D/A converter inputs the digitized raw audio and generates a raw audio analog signal for local playback and listening to the acoustic sensor signal. The compressed audio is transmitted to a remote location as a troubleshooting aid at a remote monitor.

A further aspect of a physiological acoustic monitoring system inputs a sensor signal responsive to respiratory sounds of a living being, digitizes the sensor signal so as to generate acoustic data, extracts an envelope from the acous-

tic data, defines an idealized envelope from the extracted envelope, describes the idealized envelope as breath tags and transmits the breath tags over a data channel. In various embodiments, the breath tags are received from the data channel, a reconstructed envelope is synthesized in response to the breath tags and reconstructed acoustic data is generated by filling the envelope with an artificial waveform. In an embodiment, the artificial waveform is white noise.

An additional aspect of a physiological acoustic monitoring system detects a physiological feature in the extracted envelope and includes the physiological feature in the breath tags. The reconstructed envelope is modified with the detected physiological feature, which may be wheezing or coughing, as examples. The respiratory sounds are approximately reproduced by playing the reconstructed acoustic data on an audio transducer.

Yet another aspect of a physiological acoustic monitoring system is a sensor signal responsive to respiratory sounds of a living being. An A/D converter digitizes the sensor signal into acoustic data. A parameter generator extracts a respiratory sound envelope from the acoustic data so as to generate a breath tag, which is transmitted over a data channel as a representation of the respiratory sounds. In various embodiments, a remote monitoring station receives the breath tag and a corresponding respiration rate. The monitoring station synthesizes an envelope from the breath tag and the respiration rate and fills the envelope with an artificial waveform so as to generate reconstituted respiratory sounds. In an embodiment, the artificial waveform is white noise.

In various other embodiments, a decimation filter and mixer down-samples the acoustic data to raw audio data, a D/A converter converts the raw audio data to a raw audio signal and a speaker that plays the raw audio signal. The parameter generator detects a physiological feature in the extracted envelope and includes the physiological feature in the breath tag. The remote monitor modifies the reconstructed envelope with the detected physiological feature. An audio transducer approximately reproduces the reconstructed acoustic data as compared to the raw audio signal. A compressor generates compressed audio data, which is stored and retrieved so as to generate respiration-related parameters in non-real-time.

#### BRIEF DESCRIPTION OF THE DRAWINGS

FIG. 1 is a general block diagram of a physiological acoustic monitoring system;

FIGS. 2A-B are illustrations of dual channel acoustic sensors;

FIG. 2A illustrates a neck sensor for physiological measurements and a chest sensor for monaural body sound monitoring;

FIG. 2B illustrates a dual acoustic sensor for stereo body sound monitoring;

FIGS. 3A-B are top and bottom perspective views of a body sound sensor;

FIG. 4 is a general schematic diagram of acoustic and optical sensors and sensor drive elements and a corresponding digital signal processor and I/O drive elements;

FIG. 5 is a matrix diagram of processor modules and corresponding functionality;

FIG. 6 is a network diagram for a physiological acoustic monitoring system;

FIGS. 7A-B are block diagrams of respiration sound generator embodiments;

FIGS. 8A-C are graphs illustrating breath tag generator embodiments;

FIG. 9 is a block diagram illustrating a physiological parameter processor embodiment for generating acoustic and optical sensor parameters, breath tags and compressed and raw audio outputs;

FIGS. 10A-B are a waveform and a block diagram illustrating a respiration beep generator embodiment; and

FIG. 11 is a block diagram of a physiological acoustic monitoring system for wireless monitoring applications.

#### DETAILED DESCRIPTION OF THE PREFERRED EMBODIMENTS

FIG. 1 generally illustrates a physiological acoustic monitoring system 100 embodiment having one or more sensors 110 in communications with one or more processors 130 via a sensor interface 120. The processors 130 both initiate and respond to input/output 150, including audio output 152, displays and alarms 154, communications 156 and controls 158. In an embodiment, the processors 130 are implemented in firmware executing on one or more digital signal processors (DSP), as described with respect to FIGS. 4-5, below. At least a portion of the sensors 110 generate acoustic signals, which may be directly utilized by the processors 130 or recorded onto or played back from storage media 160 or both.

The processors 130 include an audio processor 132 that outputs audio waveforms 142, a parameter processor 134 that derives physiological parameters 144 from sensor signals 112 and an acoustic data processor 136 that stores, retrieves and communicates acoustic data 146. Parameters include, as examples, respiration rate, heart rate and pulse rate. Audio waveforms include body sounds from the heart, lungs, gastrointestinal system and other organs. These body sounds may include tracheal air flow, heart beats and pulsatile blood flow, to name a few. Displays allow parameters 144 and acoustic data 146 to be visually presented to a user in various forms such as numbers, waveforms and graphs, as examples. Audio 152 allows audio waveforms to be reproduced through speakers, headphones or similar transducers. Raw audio 122 allows acoustic sensor signals 112 to be continuously reproduced through speakers, headphones or similar transducers, bypassing A/D conversion 120 and digital signal processing 130.

Storage media 160 allows acoustic data 146 to be recorded, organized, searched, retrieved and played back via the processors 130, communications 156 and audio output 152. Communications 156 transmit or receive acoustic data or audio waveforms via local area or wide area data networks or cellular networks 176. Controls 158 may cause the audio processor 132 to amplify, filter, shape or otherwise process audio waveforms 142 so as to emphasize, isolate, deemphasize or otherwise modify various features of an audio waveform or spectrum. In addition, controls 158 include buttons and switches 178, such as a "push to play" button that initiates local audio output 152 or remote transmission 176 of live or recorded acoustic waveforms.

As shown in FIG. 1, acoustic data 146 is initially derived from one or more acoustic sensor signals 112, along with, perhaps, other data inputs, such as from optical, blood pressure, EEG and ECG sensors, to name a few. The acoustic data 146 provides audio outputs 142, including audio respiration indicators, described with respect to FIGS. 7-10, below. The acoustic data 146, when analyzed, provides physiological parameters 144 that provide an indication of patient status, such as respiration rate or heart rate. Such

analyses may result in visual or audible alerts or alarms 154 that are viewed locally or via notifications transmitted over local or wide area networks 176 to medical staff or other persons. Acoustic data 146 is utilized in real time or stored and retrieved for later use. Acoustic data 146 may be written on various storage media 160, such as a hard drive, and organized for convenient search and retrieval. In an embodiment, acoustic data 146 is advantageously organized on one or more hard drives as virtual magnetic tape so as to more easily manage, search, retrieve and playback acoustic data volumes. Further, the virtual tape volumes and/or the acoustic data itself may be entered into a database and organized as an acoustic library according to various search parameters including patient information, dates, corresponding physiological parameters and acoustic waveform features, to name a few. Applications for a physiological acoustic monitoring system include auscultation of body sounds by medical staff or by audio processors or both; SIDS monitoring; heart distress monitoring including the early detection and mitigation of myocardial infarction and cardiopulmonary arrest, as examples; and elder care, to name a few.

In an embodiment, sensor sounds 142 may be continuously "piped" to a remote device/listener or a central monitor or both. Listening devices may variously include pagers, cell phones, PDAs, electronic pads or tablets and laptops or other computers to name a few. Medical staff or other remote listeners are notified by the acoustic monitoring system according to flexible pre-programmed protocols to respond to the notification so as to hear breathing sounds, voice, heart sounds or other body sounds.

FIGS. 2A-B illustrate physiological acoustic monitoring system 200 embodiments each having dual channel acoustic sensors 201, 202 in communications with a physiological monitor 205. As shown in FIG. 2A, a first acoustic sensor 210 is utilized for deriving one or more physiological parameters, such as respiration rate. A second acoustic sensor 220 is utilized to continuously monitor body sounds. In an embodiment, the second acoustic sensor 220 has a different color or shape than the first acoustic sensor 210 so as to identify the sensor as a body sound listening device rather than an acoustic sensing device for determining a physiological parameter. In an embodiment, the body sound sensor 220 is placed over the heart to allow the monitoring of heart sounds or for determination of heart rate. In an embodiment, the body sound sensor 220 generates a signal that bypasses monitor digitization and signal processing so as to allow continuous listening of the unprocessed or "raw" body sounds. In particular, the first acoustic sensor 210 is neck-mounted so as to determine one or more physiological parameters, such as respiration rate. The second acoustic sensor 220 is chest-mounted for monaural heart sound monitoring. As shown in FIG. 2B, first and second acoustic sensors 260, 270 are mounted proximate the same body site but with sufficient spatial separation to allow for stereo sensor reception. In this manner, the listener can more easily distinguish and identify the source of body sounds.

FIGS. 3A-B illustrate a body sound sensor 300 having acoustic 310, interconnect (not visible) and attachment 350 assemblies. The acoustic assembly 310 has an acoustic coupler 312 and a piezoelectric subassembly 314. The acoustic coupler 312 generally envelops or at least partially covers some or all of the piezoelectric subassembly 314. The piezoelectric subassembly 314 includes a piezoelectric membrane and a support frame (not visible). The piezoelectric membrane is configured to move on the frame in response to acoustic vibrations, thereby generating electrical signals indicative of body sounds. The acoustic coupler 312

advantageously improves the coupling between the acoustic signal measured at a skin site and the piezoelectric membrane. The acoustic coupler **312** includes a contact portion **316** placed against a person's skin.

Further shown in FIGS. 3A-B, the acoustic assembly **310** communicates with the sensor cable **340** via the interconnect assembly. In an embodiment, the interconnect assembly is a flex circuit having multiple conductors that are adhesively bonded to the attachment assembly **350**. The interconnect assembly has a solder pad or other interconnect to interface with the sensor cable **340**, and the attachment assembly **350** has a molded strain relief for the sensor cable. In an embodiment, the attachment assembly **350** is a generally circular, planar member having a top side **3511**, a bottom side **352**, and a center. A button **359** mechanically couples the acoustic assembly **310** to the attachment assembly center so that the acoustic assembly **310** extends from the bottom side **352**. The sensor cable **340** extends from one end of the interconnect and attachment assemblies to a sensor connector at an opposite end so as to provide communications between the sensor and a monitor, as described in further detail with respect to, below. In an embodiment, an adhesive along the bottom side **352** secures the acoustic assembly **310** to a person's skin, such as at a neck, chest, back, abdomen site. A removable backing can be provided with the adhesive to protect the adhesive surface prior to affixing to a person's skin. In other embodiments, the attachment assembly **350** has a square, oval or oblong shape, so as to allow a uniform adhesion of the sensor to a measurement site. In a responsible embodiment, the attachment assembly **350** or portions thereof are removably detachable and attachable to the acoustic assembly **310** for disposal and replacement. The acoustic assembly **310** is reusable accordingly.

FIG. 4 illustrates acoustic **401** and optical **402** sensors and sensor drive elements **403** and a corresponding digital signal processor **440** and I/O drive elements **404**. A multi-acoustic sensor configuration **401** includes a power interface **413**, piezo circuits **416** and a piezoelectric membrane **417** corresponding to each sensor head **406**, **407**. The piezoelectric membrane **417** senses vibrations and generates a voltage in response to the vibrations, as described with respect to the sensor of FIGS. 3A-B, above. The signal generated by the piezoelectric membrane is communicated to the piezo circuit **416**, described immediately below, and transmits the signal to the monitor **205** (FIG. 2A) for signal conditioning and processing. The piezo circuit **416** decouples the power supply **413** and performs preliminary signal conditioning. In an embodiment, the piezo circuit **416** includes clamping diodes to provide electrostatic discharge (ESD) protection and a mid-level voltage DC offset for the piezoelectric signal to ride on, to be superimposed on or to be added to. The piezo circuit may also have a high pass filter to eliminate unwanted low frequencies such as below about 100 Hz for breath sound applications, and an op amp to provide gain to the piezoelectric signal. The piezo circuit **416** may also have a low pass filter on the output of the op amp to filter out unwanted high frequencies. In an embodiment, a high pass filter is also provided on the output in addition to or instead of the low pass filter. The piezo circuit may also provide impedance compensation to the piezoelectric membrane, such as a series/parallel combination used to control the signal level strength and frequency of interest that is input to the op amp. In one embodiment, the impedance compensation is used to minimize the variation of the piezoelectric element output. The impedance compensation can be constructed of any combination of resistive, capacitive and inductive elements, such as RC or RLC circuits.

As shown in FIG. 4, a physiological acoustic monitor **400** embodiment drives and processes signals from a multi-acoustic sensor **401** and an optical sensor **402**. The monitor **400** includes one or more acoustic front-ends **421**, **422**, an analog-to-digital (A/D) converter **431**, an audio driver **470** and a digital signal processor (DSP) **440**. The DSP **440** can comprise a wide variety of data and/or signal processors capable of executing programs for determining physiological parameters from input data. An optical front-end **425**, digital-to-analog (D/A) converters **434** and an A/D converter **435** drive emitters **408** and transform resulting composite analog intensity signal(s) from light sensitive detector(s) **409** received via a sensor cable **410** into digital data input to the DSP **440**. The acoustic front-ends **421**, **422** and A/D converter **431** transform analog acoustic signals from piezoelectric elements **401** into digital data input to the DSP **440**. The A/D converter **431** is shown as having a two-channel analog input and a multiplexed digital output to the DSP. In another embodiment, each front-end, communicates with a dedicated single channel A/D converter generating two independent digital outputs to the DSP. An acoustic front-end **421** can also feed an acoustic sensor signal **411** directly into an audio driver **470** for direct and continuous acoustic reproduction of an unprocessed (raw) sensor signal by a speaker, earphones or other audio transducer **462**, as described with respect to FIG. 9, below.

Also shown in FIG. 4, the physiological acoustic monitor **400** may also have an instrument manager **450** that communicates between the DSP **440** and input/output **460**. One or more I/O devices **460** have communications with the instrument manager **450** including displays, alarms, user I/O and instrument communication ports. Alarms **466** may be audible or visual indicators or both. The user I/O **468** may be, as examples, keypads, touch screens, pointing devices or voice recognition devices, to name a few. The displays **464** may be indicators, numerics or graphics for displaying one or more of various physiological parameters or acoustic data. The instrument manager **450** may also be capable of storing or displaying historical or trending data related to one or more of parameters or acoustic data.

Further shown in FIG. 4, the physiological acoustic monitor **400** may also have a "push-to-talk" feature that provides a "listen on demand" capability. That is, a button **468** on the monitor is pushed or otherwise actuated so as to initiate acoustic sounds to be sent to a speaker, handheld device, or other listening device, either directly or via a network. The monitor **400** may also has a "mode selector" button or switch **468** that determines the acoustic content provided to a listener, either local or remote. These controls may be actuated local or at a distance by a remote listener. In an embodiment, push on demand audio occurs on an alarm condition in lieu of or in addition to an audio alarm. Controls **468** may include output filters like on a high quality stereo system so that a clinician or other user could selectively emphasize or deemphasize certain frequencies so as to hone-in on particular body sounds or characteristics.

In various embodiments, the monitor **400** may be one or more processor boards installed within and communicating with a host instrument. Generally, a processor board incorporates the front-end, drivers, converters and DSP. Accordingly, the processor board derives physiological parameters and communicates values for those parameters to the host instrument. Correspondingly, the host instrument incorporates the instrument manager and I/O devices. A processor board may also have one or more microcontrollers (not shown) for board management, including, for example, communications of calculated parameter data and the like to

the host instrument. A processor board embodiment is described with respect to FIG. 9, below.

Communications 469 may transmit or receive acoustic data or audio waveforms via local area or wide area data networks or cellular networks. Controls may cause the audio processor to amplify, filter, shape or otherwise process audio waveforms so as to emphasize, isolate, deemphasize or otherwise modify various features of the audio waveform or spectrum. In addition, switches, such as a “push to play” button can initiate audio output of live or recorded acoustic data. Controls may also initiate or direct communications.

FIG. 5 illustrates processor modules 500 that may execute on a DSP 440 (FIG. 4) and/or instrument manager 450 (FIG. 4) in various physiological acoustic monitoring system embodiments and the corresponding functionality of these modules. Module functionality includes processing sensor input 510, storage 520 and playback 530 of acoustic data, acoustic data analysis 540, communication of acoustic data and derived physiological parameters 550 and specific applications 560. Sensor input 510 related modules include dynamic range 512 and noise reduction 513. Dynamic range 512 functionality is described with respect to the processor board codec and FIG. 9, below. Storage 520 related modules include virtual tape 523 and database 524 functionality, described with respect to FIG. 6, below. Playback 530 functionality includes audio filters 532, sound reproduction 534 including mono/stereo/quadrasonic 533 modes and auscultation 535 enhancement. Analysis 540 related modules include audio parameters 542, multi-sensor parameters 543 and corresponding alarms 544. Communications 550 related modules include cellular 553, wireless 554 and network 555 modes. Wireless is described with respect to FIG. 11, below, and cellular 553 and networks 555 are described with respect to FIG. 6, below. Applications 560 include elder care 561 and SIDS 562, described with respect to FIG. 12, below.

FIG. 6 illustrates a physiological acoustic monitoring system 600 embodiment having a shared or open network architecture interconnecting one or more physiological monitors 610, monitoring stations 620 and mass storage 660. This interconnection includes proximity wireless devices 612 in direct wireless communication with a particular physiological monitor 610; local wireless devices 632 in communications with the monitors 610 via a wireless LAN 630; and distant wired or wireless devices 642, 652 in communications with the monitors 610 via WAN, such as Internet 640 or cellular networks 650. Communication devices may include local and remote monitoring stations 620 and wired or wireless communications and/or computing devices including cell phones, lap tops, pagers, PDAs, tablets and pads, to name a few. Physiological information is transmitted/received directly to/from end users over LAN or WAN. End users such as clinicians may carry wireless devices 632 in communications with the WLAN 630 so as to view in real-time physiological parameters or listen to audio data and waveforms on demand or in the event of an alarm or alert.

The network server 622 in certain embodiments provides logic and management tools to maintain connectivity between physiological monitors, clinician notification devices and external systems, such as EMRs. The network server 622 also provides a web based interface to allow installation (provisioning) of software related to the physiological monitoring system, adding new devices to the system, assigning notifiers to individual clinicians for alarm notification, escalation algorithms in cases where a primary caregiver does not respond to an alarm, interfaces to provide

management reporting on alarm occurrences and internal journaling of system performance metrics such as overall system uptime. The network server 622 in certain embodiments also provides a platform for advanced rules engines and signal processing algorithms that provide early alerts in anticipation of a clinical alarm.

As shown in FIG. 6, audio data and corresponding audio files are advantageously stored on virtual tape 662, which provides the storage organization of tape cartridges without the slow, bulky, physical storage of magnetic tape and the corresponding human-operator intervention to physically locate and load physical cartridges into an actual tape-drive. A virtual tape controller 662 emulates standard tape cartridges and drives on modern, high capacity disk drive systems, as is well-known in the art. Accordingly, virtual “audio tapes” appear the same as physical tapes to applications, allowing the use of many existing cartridge tape storage, retrieval and archival applications. Further, while the upper-limit of a physical tape cartridge may be a few hundred megabytes, a virtual tape server 662 can be configured to provide considerably larger “tape” capacity. Mount-time is near-zero for a virtual tape and the data is available immediately. Also, while traditional physical tape systems have to read a tape from the beginning, moving sequentially through the files on the tape, a virtual drive can randomly access data at hard-disk speeds, providing tape I/O at disk access speeds.

Additionally shown in FIG. 6, a sound processing firmware module of certain embodiments accesses a database 670 of sound signatures 660 and compares the received signal with the entries in the database to characterize or identify sounds in the received signal. In another embodiment, the sound processing module generates and/or accesses a database 670 of sound signatures specific to a patient, or specific to a particular type of patient (e.g., male/female, pediatric/adult/geriatric, etc.). Samples from a person may be recorded and used to generate the sound signatures. In some embodiments, certain signal characteristics are used to identify particular sounds or classes of sounds. For example, in one embodiment, signal deviations of relatively high amplitude and or sharp slope may be identified by the sound processing module. Sounds identified in various embodiments by the sound processing module include, but are not limited to, breathing, speech, choking, swallowing, spasms such as larynx spasms, coughing, gasping, etc.

Once the sound processing module characterizes a particular type of sound, the acoustic monitoring system can, depending on the identified sound, use the characterization to generate an appropriate response. For example, the system may alert the appropriate medical personnel to modify treatment. In one embodiment, medical personnel may be alerted via an audio alarm, mobile phone call or text message, or other appropriate means. In one example scenario, the breathing of the patient can become stressed or the patient may begin to choke due to saliva, mucosal, or other build up around an endotracheal tube. In an embodiment, the sound processing module can identify the stressed breathing sounds indicative of such a situation and alert medical personnel to the situation so that a muscle relaxant medication can be given to alleviate the stressed breathing or choking.

According to some embodiments, acoustic sensors described herein can be used in a variety of other beneficial applications. For example, an auscultation firmware module may process a signal received by the acoustic sensor and provide an audio output indicative of internal body sounds



of the patient, such as heart sounds, breathing sounds, gastrointestinal sounds, and the like. Medical personnel may listen to the audio output, such as by using a headset or speakers. In some embodiments the auscultation module allows medical personnel to remotely listen for patient diagnosis, communication, etc. For example, medical personnel may listen to the audio output in a different room in a hospital than the patient's room, in another building, etc. The audio output may be transmitted wirelessly (e.g., via Bluetooth, IEEE 802.11, over the Internet, etc.) in some embodiments such that medical personnel may listen to the audio output from generally any location.

FIGS. 7A-B illustrate sound processing embodiments **701**, **702** for generating an audio output for an acoustic sensor. As shown in FIG. 7A, in one embodiment, acoustic sensor data is A/D converted **710**, down-sampled with a decimation filter **720** and compressed **730**. The compressed audio data **732** is transmitted to a monitor, which decompresses the data **740** and outputs it to a speaker **742** or similar audio transducer. However, compressed audio data **732** from a physiological acoustic sensor has too high a bit rate to transmit over monitor data channels shared with other physiological processors or patient networks shared by multiple patient monitors all communicating physiological parameters, waveforms and other real-time medical data. Acoustic sensor data rates are described in further detail with respect to FIG. 9, below.

As shown in FIG. 7B, an envelope-based sound processing **702** embodiment advantageously allows respiration-related acoustic data to be transmitted at significantly reduced data rates compared with data compression so as to allow shared transmission over monitor data channels (**990** FIG. 9) and patient networks. Respiration-related acoustic data is A/D converted **710** and input to an envelope detector **750**. The detected envelopes are idealized and represented by a small number set or "tag" corresponding to each breath. In an embodiment, a breath tag represents the time-of-occurrence of the breath envelope peak for each inspiration and expiration cycle. These breath tags **760** are then transmitted over standard multiple parameter patient monitor data channels and/or patient networks. At the receiving end, a patient monitor, multiple patient monitoring system or like monitoring device synthesizes the envelopes **770** from the breath tags **760** according to the respiration rate (RR). The envelopes **770** are then filled with white noise **780** so as to simulate the original respiration acoustic data **782**.

FIGS. 8A-C further illustrate envelope processing for acoustic sensor data. FIG. 8A illustrates a representative acoustic signal **801** derived by a neck sensor detecting vibrations resulting from tracheal air flow during respiration. A breath sound **810** has an envelope **820** "pulse" corresponding to either inhalation or exhalation. An envelope detector **750** (FIG. 7B) generates breath tags that numerically describe the envelope **820**. As shown in FIG. 8B, in one embodiment, breath tags describe an idealized envelope **830**. For example, a breath tag may be an amplitude value and a duration value for each idealized pulse. In other embodiments, a breath tag may include leading/trailing slope values for a pulse **830**. As shown in FIG. 8C, in other embodiments, breath tags include detected envelope features **842**, **843**, **844** that are characteristic of known acoustically-related phenomena such as wheezing or coughing, as examples. At a receiving device, envelop synthesis **770** (FIG. 7B) reproduces an envelope **830**, **840** and fills the envelope with an artificial waveform, such as white noise. This reconstructed or simulated breath signal is then output to a speaker or similar device. In other embodiments, breath tags are trans-

mitted over a network to a remote device, which reconstructs breathing waveforms from the breath tags in like manner.

In various other embodiments, acoustic breathing waveforms are detected by an acoustic sensor, processed, transmitted and played on a local or remote speaker or other audio output from actual (raw) data, synthetic data and artificial data. Actual data may be compressed, but is a nearly complete or totally complete reproduction of the actual acoustic sounds at the sensor. Synthetic data may be a synthetic version of the breathing sound with the option of the remote listener to request additional resolution. Artificial data may simulate an acoustic sensor sound with minimal data rate or bandwidth, but is not as clinically useful as synthetic or actual data. Artificial data may be, for example, white noise bursts generated in sync with sensed respiration. Synthetic data is something between actual data and artificial data, such as the acoustic envelope process described above that incorporates some information from the actual sensor signal. In an embodiment breath sounds are artificially hi/lo frequency shifted or hi/lo volume amplified to distinguish inhalation/exhalation. In an embodiment, dual acoustic sensors placed along the neck are responsive to the relative time of arrival of tracheal sounds so as to distinguish inhalation and exhalation in order to appropriately generate the hi/lo frequency shifts. Raw and compressed acoustic respiration data is described with respect to FIG. 9, below. Artificial data "breath beeps" are described with respect to FIGS. 10A-B, below.

FIG. 9 illustrates a processor board **900** embodiment of an acoustic monitoring system that generates both optical and acoustic data. An optical portion has D/A converters **958** responsive to emitter drives **954** and an emitter control **950** so as to alternately activate optical sensor **902** LEDs of multiple wavelengths so as to illuminate blood perfused tissue. An A/D converter **960** and demodulator **964** are responsive to sensor **902** detectors so as to generate plethysmographic data **968** to a digital signal processor (DSP) **980**. Corresponding blood parameter algorithms **970** generate blood parameter outputs **972**, such as oxygen saturation (SpO<sub>2</sub>), to a data channel **990**.

Also shown in FIG. 9, an acoustic portion has an A/D converter **910**, a decimation filter and mixer **920**, a coder/compressor **930** and a decoder/decompressor **935** so as to generate acoustic data to the DSP **980**. The A/D **910**, decimation filter/mixer **920** and a D/A converter **925** are responsive to an acoustic sensor **901** so as to generate an analog "raw" audio **909** output. In an embodiment, the A/D **910** is a 48 KHz, 16-bit, 2-channel variable gain device that provides higher resolution at lower signal amplitudes and lower resolution and higher signal amplitudes. In an embodiment, the decimation filter/mixer generates 2 KHz, 32-bit (64 Kbps) digitized raw audio **922**. Advantageously, the raw audio **909** is routed to a proximate amplifier/speaker **122** (FIG. 1). The digitized raw audio **922** is also input to the coder/compressor **930**. A 3:1 (approx.) compression generates a 20 Kbps compressed (digitized) audio **908** output. The compressed audio **908** is immediately input into a decoder/decompressor **935** for use by acoustic algorithms **940** to generate respiration rate (RR) and breath tag **942** outputs to a data channel **990**, as described above, among other acoustic-related parameters. Advantageously, the compression and immediate decompression of the digitized raw audio **922** provides a compressed audio output **908** that can be stored and retrieved for accurate off-line reproduction and troubleshooting of device behavior. Also, the compressed audio output **908** can be advantageously transmitted via

Wi-Fi or other communication links to remote locations for processing and patient analysis.

FIGS. 10A-B illustrate a “respiration beep” embodiment **1001** for communicating reduced-rate respiration data over relatively low bandwidth monitor data channels and patient networks. As shown in FIG. 10A, in some situations, acoustic respiration data **1000** presents an inspiration (I) **1010** pulse relatively closely followed by an expiration (E) **1020** pulse, where each I/E pair is separated by a relatively longer pulseless interval. That is, these I/E pairs are relatively easily distinguished. As such, I/E pairs can be transmitted as simply time-of-occurrence values.

As shown in FIG. 10B, at an inspiration time **1062**, a high (HI) frequency tone **1064** is generated. At an expiration time **1062**, a low (LO) frequency tone **1064** is generated. A mixer **1050** combines colored noise **1042** with the HI/LO tones **1064** to generate higher-pitched followed by lower-pitched noise pulses representative of the original acoustic waveform **1000**. These respiration “beeps” are roughly analogous to pulse oximeter-generated “beeps” that coincide with optical sensor detected arterial blood pulses. In an advantageous embodiment, a processor board **900** (FIG. 9) having optical and acoustic sensors generates simultaneously occurring respiration beeps and pulse beeps, where the pulse beep tone is easily distinguished from the respiration beep HI/LO noise pulses. These combined pulse/respiration beeps advantageously allow a care provider to “monitor” a patient’s respiration and pulse by sound alone.

FIG. 11 illustrates a wireless physiological acoustic monitor **1100** embodiment, which is particular advantageous for out-patient applications, such as sudden infant death syndrome (SIDS) prevention and elder care. The monitor **1100** has a sensor section **1101** and a remote section **1102**. The sensor section **1101** has a sensor **1110**, a sensor interface **1120** and a communications element **1130**. In an embodiment, the sensor **1110** is an adhesive substrate integrated with a piezoelectric assembly and interconnect cable, such as described with respect to FIGS. 3A-B, above. The sensor interface **1120** provides power to and receives the sensor signal from the sensor piezo circuit, as described with respect to FIG. 4, above. The wireless communications element **1130** receives the sensor signal from the sensor interface **1120** and transmits the signal to the corresponding communications element **1140** in the remote section **1102**, which provides an amplified sensor signal sufficient to drive a small speaker. In an embodiment, the communications link **1160** conforms with IEEE 802.15 (Bluetooth).

A physiological acoustic monitoring system has been disclosed in detail in connection with various embodiments. These embodiments are disclosed by way of examples only and are not to limit the scope of the claims that follow. One of ordinary skill in art will appreciate many variations and modifications.

What is claimed is:

1. A system for transmitting physiological sounds of a patient across a network, the system comprising:
  - a body sound sensor configured to detect a sound signal corresponding to a physiological process; and
  - one or more hardware processors configured to:
    - convert the detected sound signal from an analog signal to a digital signal;
    - compress the converted sound signal;
    - generate a tag corresponding a physiological sound, said tag indicating a time of occurrence of the physiological sound within the detected sound signal;
    - transmit, over a network, the compressed sound signal and the tag corresponding to the physiological sound, wherein the tag enables a remote computing system to identify the time of occurrence of the physiological sound in the transmitted sound signal.
2. The system of claim 1, wherein the one or more hardware processors are further configured to down sample the converted sound signal with a decimation filter prior to the compression.
3. The system of claim 1, wherein the remote computing system includes a control configured to enable a user to selectively emphasize a first range of frequencies.
4. The system of claim 1, wherein the one or more hardware processors are further configured to apply envelope based sound processing to the compressed sound signal.
5. The system of claim 4, wherein the one or more hardware processors are configured to transmit the envelope based processed signal in lieu of the compressed sound signal.
6. The system of claim 5, wherein the one or more hardware processors are configured to generate an artificial sound signal that correspond to the detected sound signal based on the received envelope based processed signal.
7. The system of claim 1, wherein the body sound sensor comprises a piezoelectric sensor.
8. The system of claim 1, wherein the physiological sound comprises coughing.
9. The system of claim 1, wherein the one or more hardware processors are configured to detect respiration rate from the converted sound signal.
10. The system of claim 1, wherein the tag is generated based on detection of features in the converted sound signal.
11. The system of claim 10, wherein the features comprise relatively high amplitude.
12. The system of claim 10, wherein the features comprise a sharp slope.

\* \* \* \* \*