



US010908406B2

(12) **United States Patent**  
**Hadley et al.**

(10) **Patent No.:** **US 10,908,406 B2**  
(45) **Date of Patent:** **Feb. 2, 2021**

(54) **RESONANT SCANNER INTEROPERATION WITH MOVABLE STAGE**

21/0028 (2013.01); *G02B 21/0032* (2013.01);  
*G02B 21/0048* (2013.01)

(71) Applicant: **CALIBER IMAGING & DIAGNOSTICS, INC.**, Rochester, NY (US)

(58) **Field of Classification Search**  
CPC ..... *G02B 21/26*; *G02B 21/0028*;  
*G02B 21/0032*; *G02B 21/0048*; *G02B 21/008*; *G01N 33/4833*  
USPC ..... 359/213.1  
See application file for complete search history.

(72) Inventors: **Keith Aaron Hadley**, Rochester, NY (US); **Jason William Faulring**, Livonia, NY (US); **Paul Michael Hemmer**, Rochester, NY (US); **James Vincent Massaro**, Rochester, NY (US)

(56) **References Cited**

(73) Assignee: **Caliber Imaging & Diagnostics, Inc.**, Rochester, NY (US)

U.S. PATENT DOCUMENTS

(\*) Notice: Subject to any disclaimer, the term of this patent is extended or adjusted under 35 U.S.C. 154(b) by 0 days.

5,788,639 A	8/1998	Zavislan et al.
5,880,880 A	3/1999	Anderson et al.
6,429,968 B1	8/2002	Carver
7,394,592 B2	7/2008	Fox et al.
9,055,867 B2	6/2015	Fox et al.
9,339,178 B2	5/2016	Yu et al.
9,952,205 B2	4/2018	Abeytunge et al.
10,459,211 B2 *	10/2019	Hadley ..... <i>G02B 21/0048</i>

(Continued)

(21) Appl. No.: **16/663,969**

(22) Filed: **Oct. 25, 2019**

OTHER PUBLICATIONS

(65) **Prior Publication Data**  
US 2020/0064613 A1 Feb. 27, 2020

Abeytunge, S. et al., Rapid confocal imaging of large areas of excised tissue with strip mosaicing, *Journal of Biomedical Optics*, vol. 16(5), May 2011.

(Continued)

**Related U.S. Application Data**

(63) Continuation of application No. 15/730,668, filed on Oct. 11, 2017, now Pat. No. 10,459,211.

*Primary Examiner* — Euncha P Cherry

(60) Provisional application No. 62/406,841, filed on Oct. 11, 2016.

(74) *Attorney, Agent, or Firm* — Kenneth J. Lukacher Law Group; R. Stephen Rosenholm

(51) **Int. Cl.**  
*G02B 26/08* (2006.01)  
*G02B 21/26* (2006.01)  
*G01N 33/483* (2006.01)  
*G02B 21/00* (2006.01)

(57) **ABSTRACT**

A system, apparatus and method and method for controlling interoperation between a resonant scanner and a movable stage. The movable stage being employed to position a specimen for optical scanning by the resonant scanner. The invention providing high resolution scanning of specimen tissue at a rate of ten times or more faster than other known methods of optically scanning a specimen.

(52) **U.S. Cl.**  
CPC ..... *G02B 21/26* (2013.01); *G01N 33/4833* (2013.01); *G02B 21/008* (2013.01); *G02B*

**20 Claims, 7 Drawing Sheets**

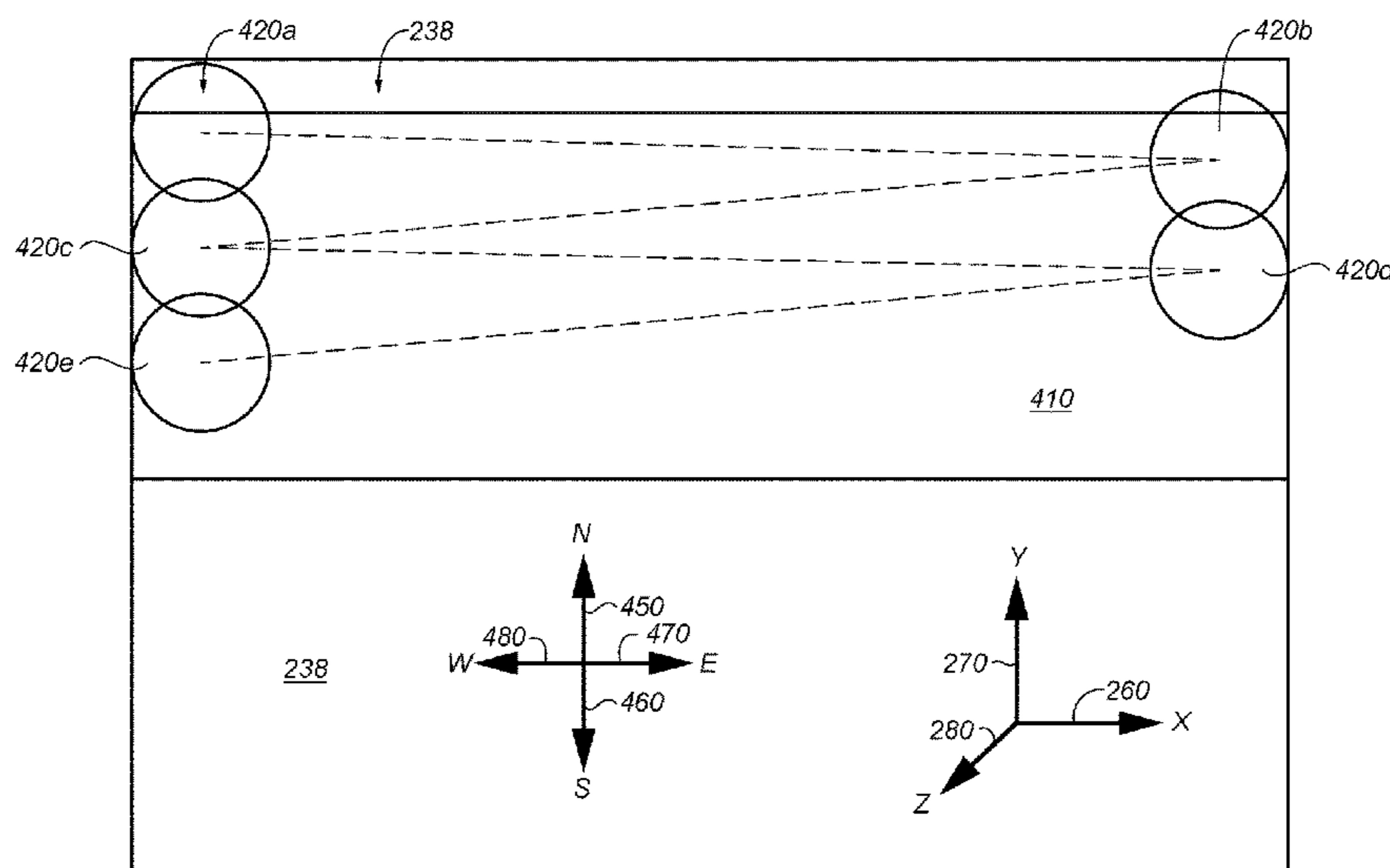

(56)

**References Cited**

U.S. PATENT DOCUMENTS

2003/0206341 A1 11/2003 Wolleschensky et al.  
2004/0119004 A1 6/2004 Wine et al.  
2004/0133112 A1 7/2004 Rajadhyaksha  
2015/0173606 A1 6/2015 Yu et al.  
2015/0351633 A1 12/2015 Fox et al.

OTHER PUBLICATIONS

Abeytunge, S. et al., Confocal microscopy with strip mosaicing for rapid imaging over large areas of excised tissue, *Journal of Biomedical Optics*, vol. 18(6), Jun. 2013.

\* cited by examiner

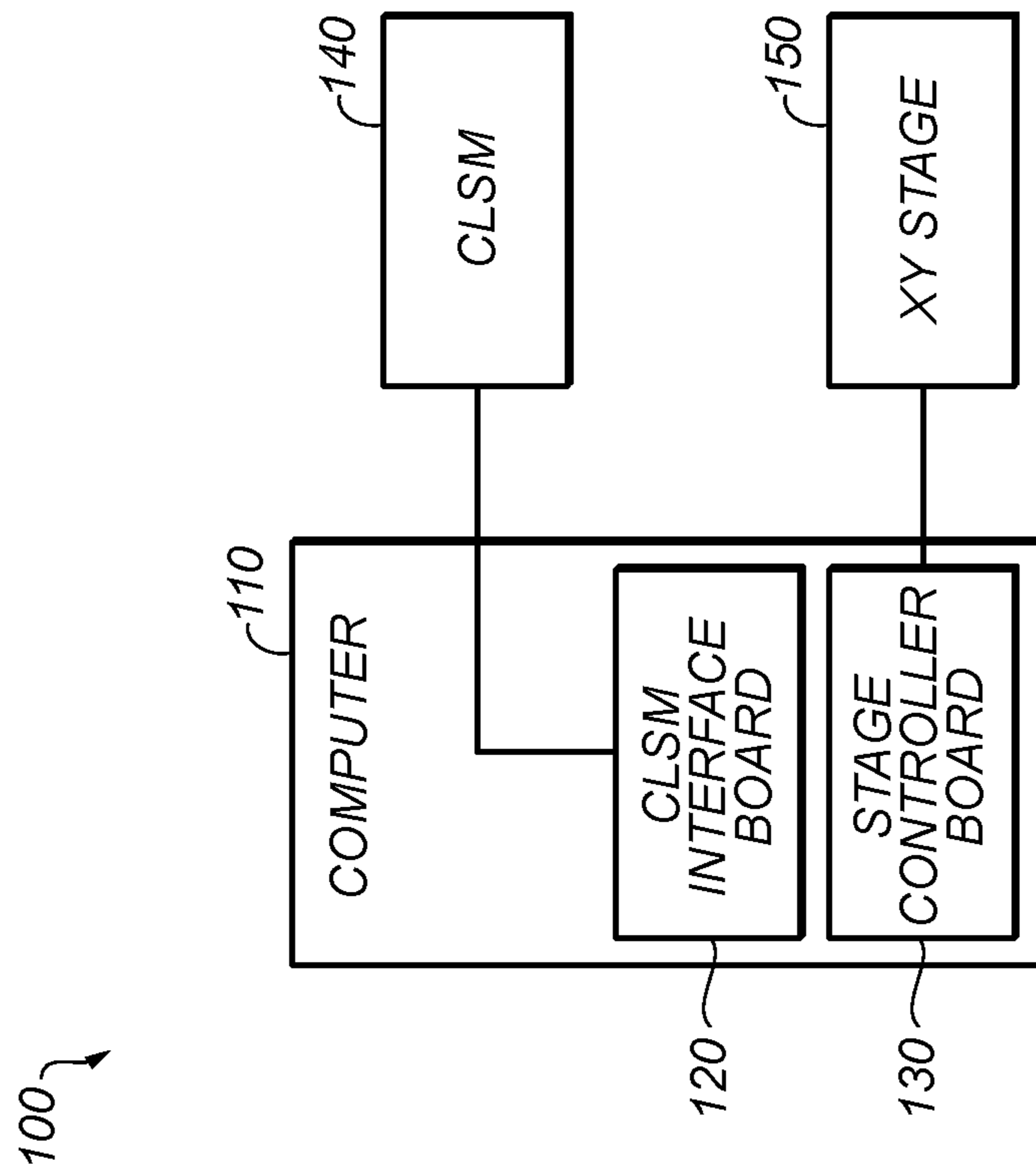

**FIG. 1**

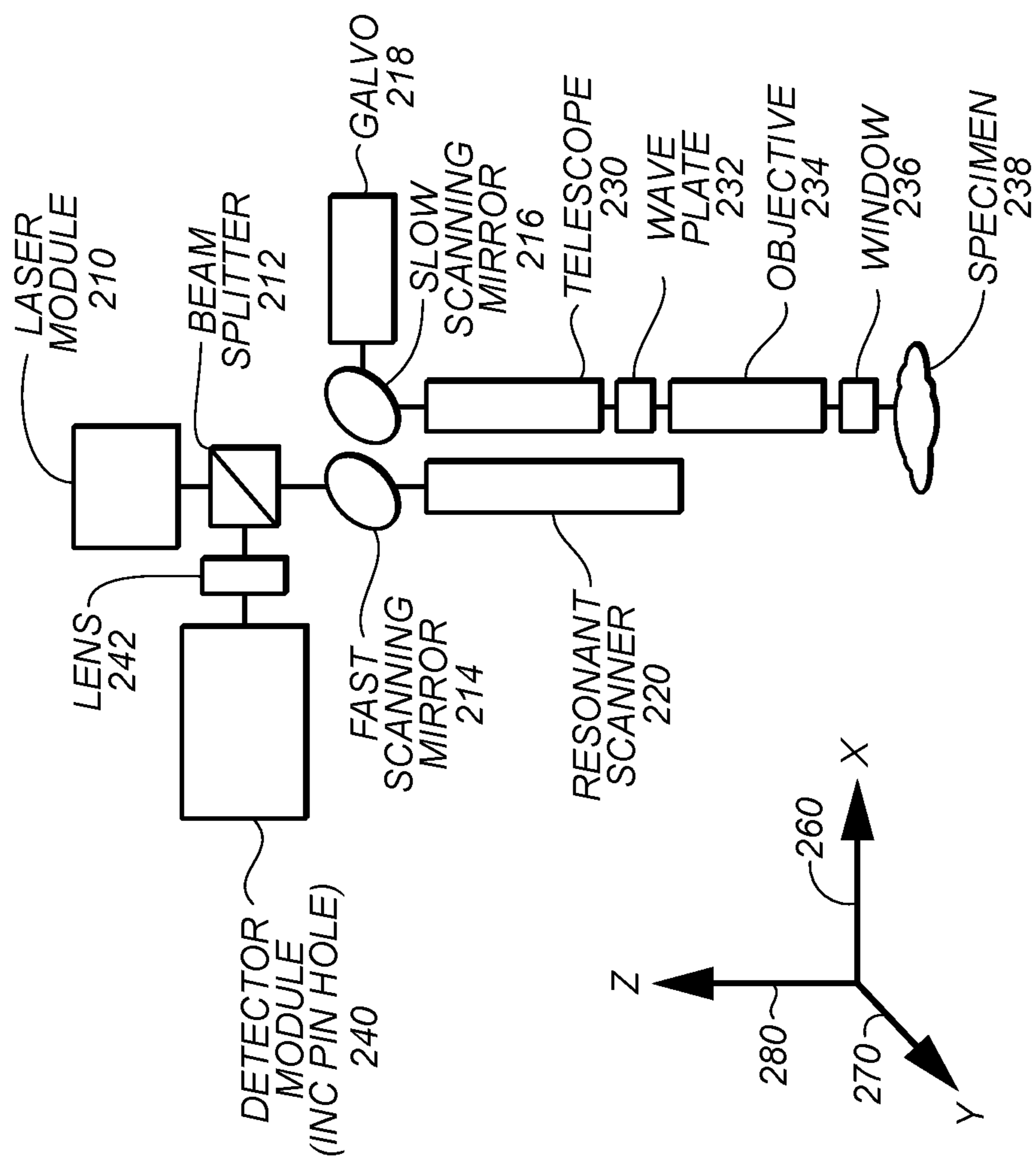

FIG. 2

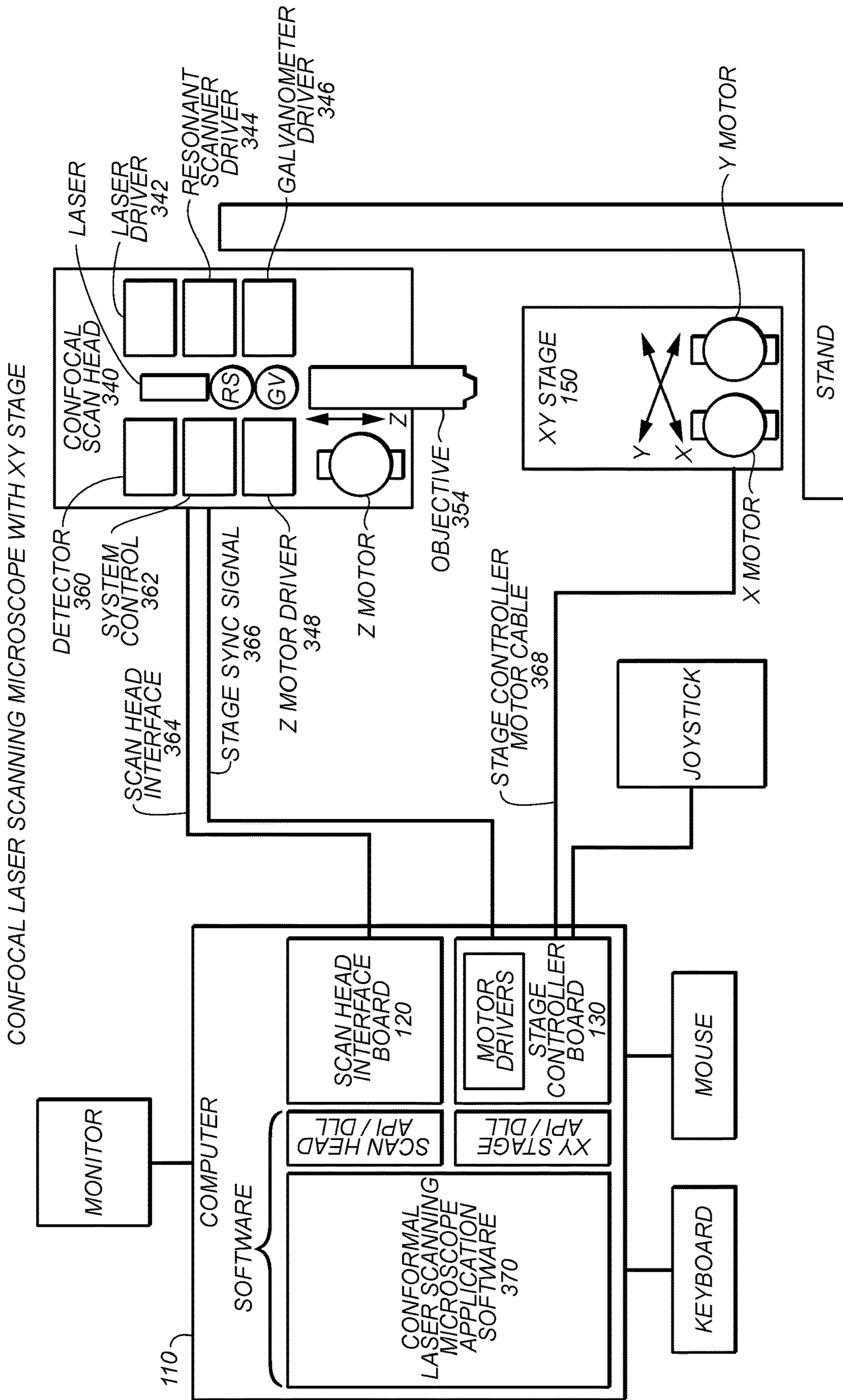

FIG. 3

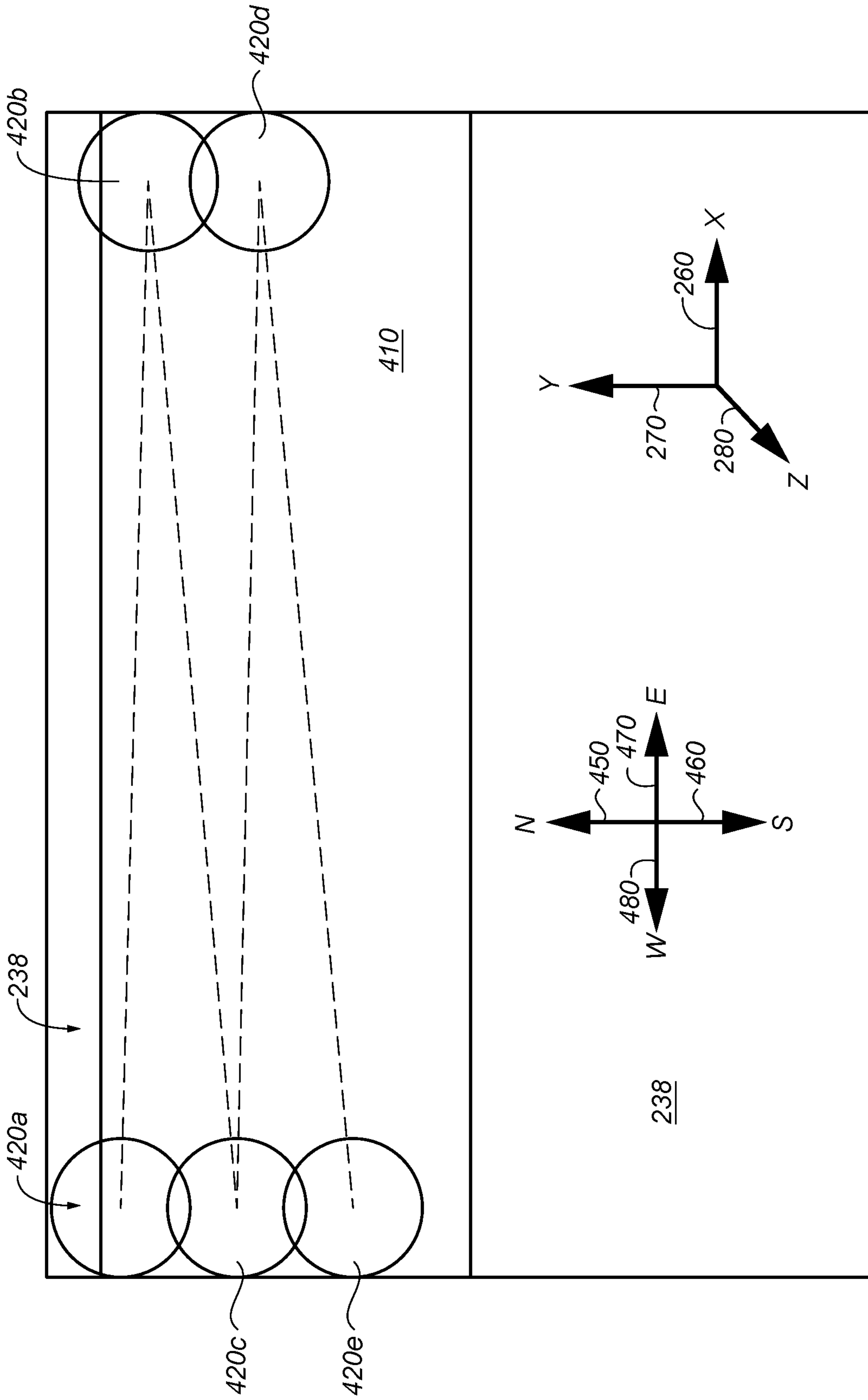
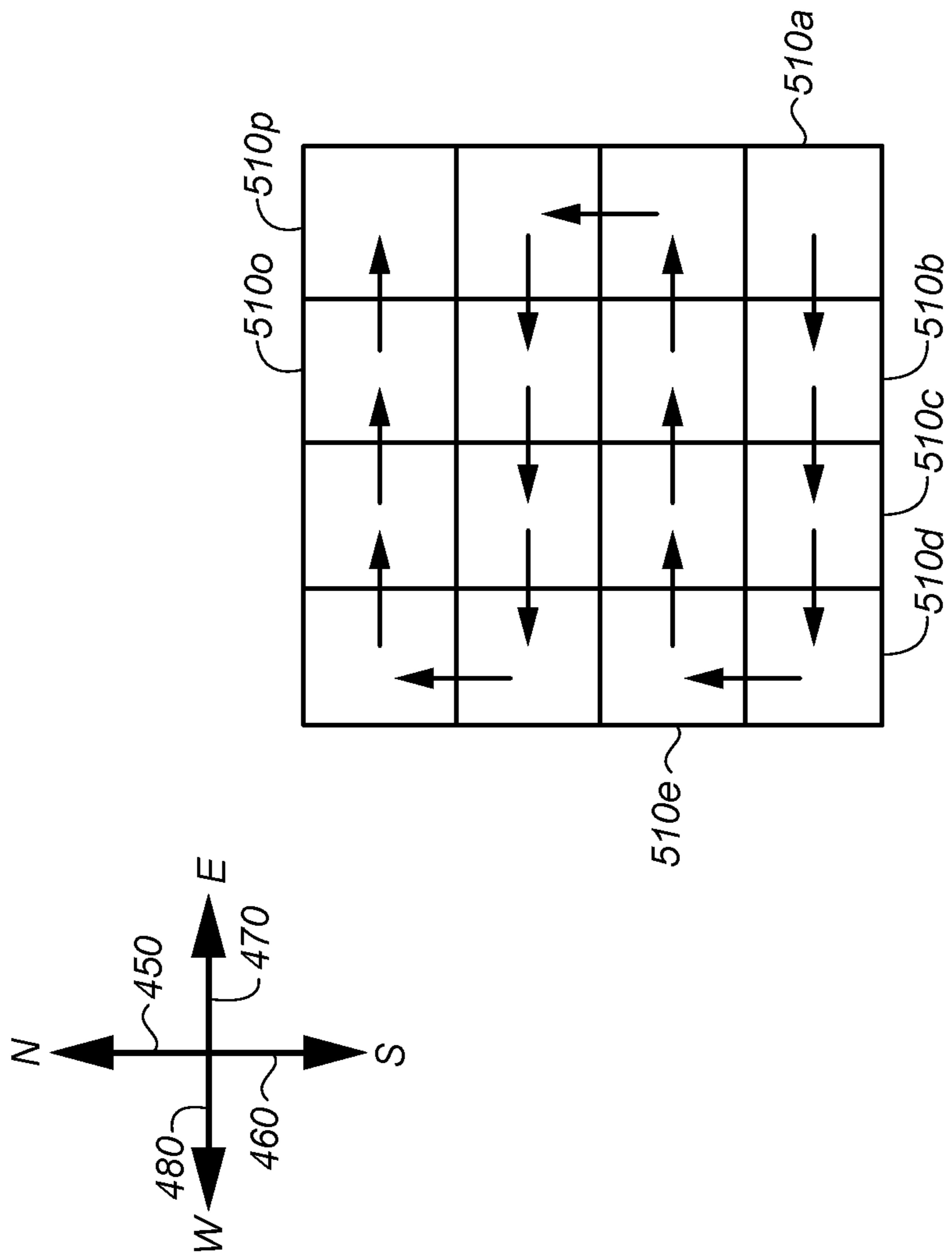
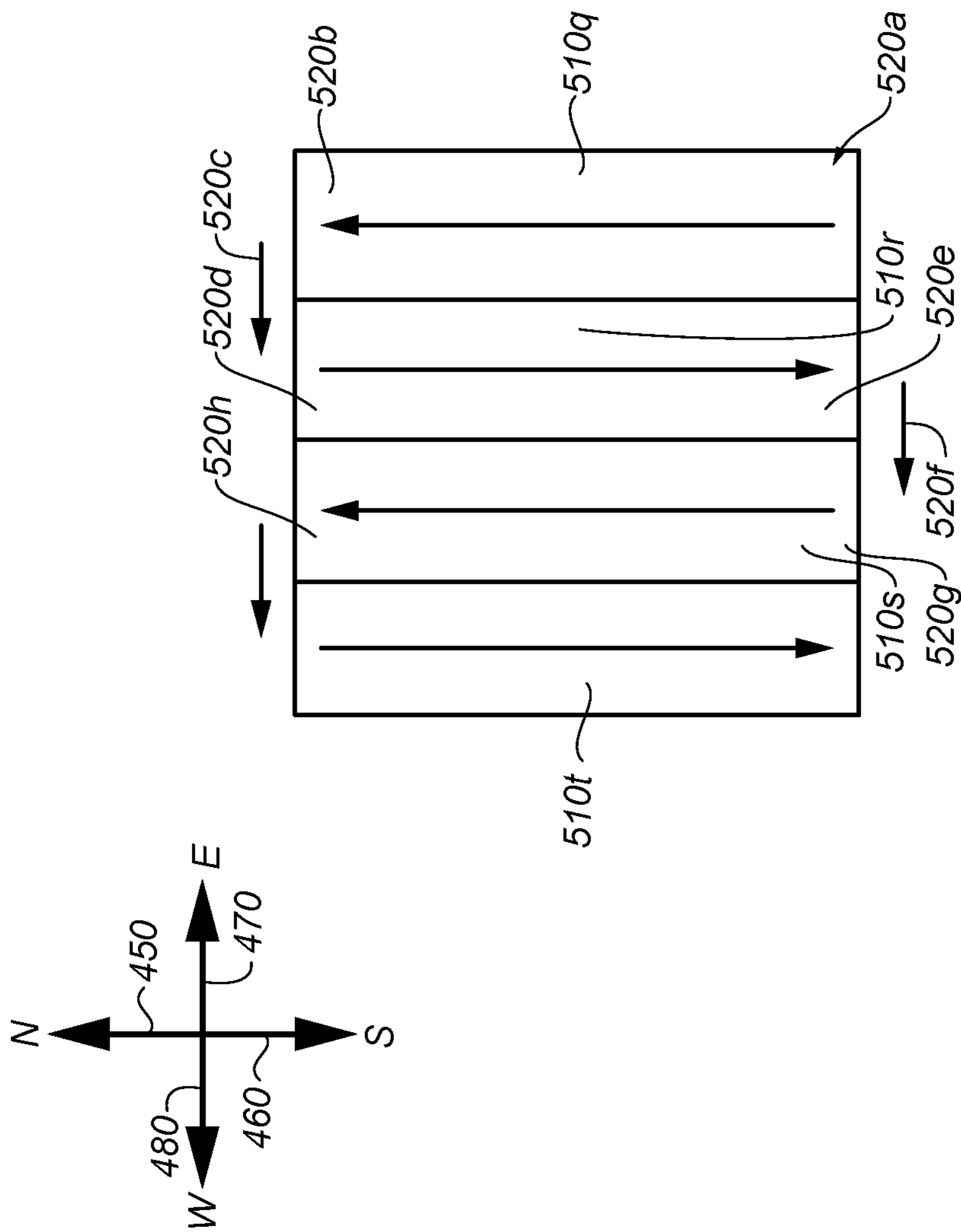

FIG. 4



**FIG. 5A**



**FIG. 5B**



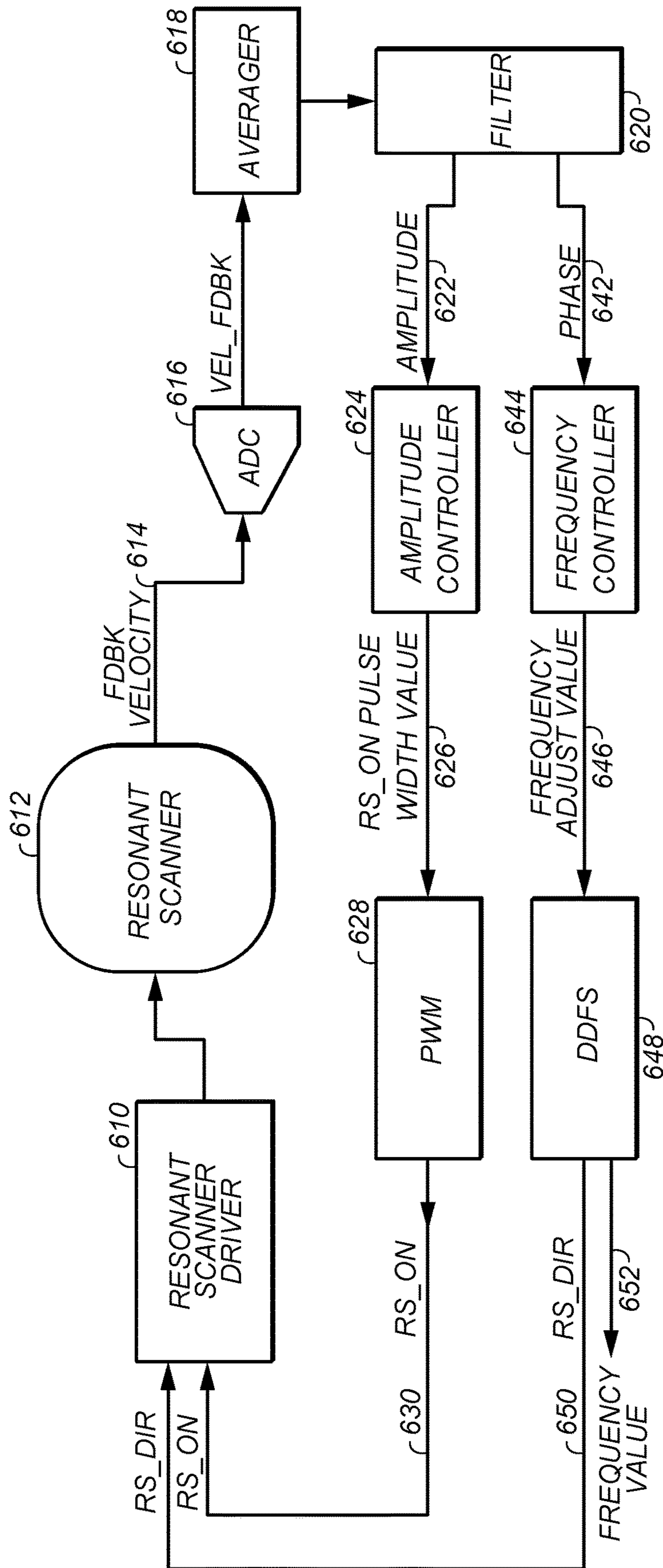

FIG. 6

## RESONANT SCANNER INTEROPERATION WITH MOVABLE STAGE

### CROSS REFERENCE TO RELATED PATENT APPLICATION(S)

This document is a continuing U.S. non-provisional utility patent application being filed under 37 CFR 1.53(b), that claims priority and benefit to, U.S. non-provisional utility patent application Ser. No. 15/730,668 which was filed on Oct. 11, 2017, and that is entitled "RESONANT SCANNER INTEROPERATION WITH MOVABLE STAGE", and which is also incorporated herein by reference in its entirety. The U.S. non-provisional utility patent application Ser. No. 15/730,688, claims priority and benefit to U.S. (utility) provisional patent application having Ser. No. 62/406,841, (Confirmation No. 3165), that was filed on Oct. 11, 2016, and that is entitled "CONTROLLING INTER-OPERATION BETWEEN A RESONANT SCANNER AND A MOVABLE STAGE". All of the above referenced documents are each incorporated herein by reference in their entirety.

### PATENT APPLICATION(S) INCLUDING RELATED SUBJECT MATTER

This document is a United States non-provisional utility patent application, that includes subject matter generally related to that of U.S. Pat. No. 9,055,867 to Fox et al., that was issued on Jun. 16, 2015 and entitled "CONFOCAL SCANNING MICROSCOPE HAVING OPTICAL AND SCANNING SYSTEMS WHICH PROVIDE A HANDHELD IMAGING HEAD".

This document includes subject matter that is also generally related to that of U.S. Patent Publication No. 2015/0351633 which was published on Dec. 10, 2015 and that was filed as a continuation patent application related to the prior filed U.S. patent application Ser. No. 11/920,195, which later issued as the U.S. Pat. No. 9,055,867 referred to above. The aforementioned patents, patent publications and patent applications are incorporated herein by reference in their entirety.

### FIELD OF THE INVENTION

An apparatus for controlling interoperation between a resonant scanner and a movable stage. The movable stage being employed to position a specimen for optical scanning by the resonant scanner.

### BACKGROUND OF THE INVENTION

A resonant scanner employs a resonating mirror that deflects and directs a beam of light. A position of the resonating mirror is dynamic over time, and meaning that the mirror is designed to resonate (oscillate) over time in accordance with a particular oscillating frequency. Such resonating causes a direction of the beam of light to also oscillate and change over time.

The discussion above is merely provided for general background information and is not intended to be used as an aid in determining the scope of the claimed subject matter.

### BRIEF DESCRIPTION OF THE INVENTION

An apparatus, system and method for controlling interoperation between a resonant scanner and a movable stage. The movable stage being employed to position a specimen

for optical scanning by the resonant scanner. The invention providing high resolution scanning of specimen tissue at a rate exceeding a factor of ten times faster than other known methods of optically scanning a specimen.

This brief description of the invention is intended only to provide a brief overview of subject matter disclosed herein. This brief description is not intended to identify key features or essential features of the claimed subject matter, nor is it intended to be used as an aid in determining the scope of the claimed subject matter.

### BRIEF DESCRIPTION OF THE DRAWINGS

So that the manner in which the features of the invention can be understood, a detailed description of the invention may be had by reference to certain embodiments, some of which are illustrated in the accompanying drawings. The drawings are not necessarily to scale, and the emphasis generally being placed upon illustrating the features of certain embodiments of the invention. In the drawings, like numerals are used to indicate like parts throughout the various views. For further understanding of the invention, reference can be made to the following detailed description, read in connection with the drawings in which:

FIG. 1 illustrates a block diagram of an embodiment of an electrical interface between a confocal laser scanning microscope (CLSM) and a movable stage.

FIG. 2 illustrates a block diagram of some of the internal components within an embodiment of a confocal laser scanning microscope (CLSM).

FIG. 3 illustrates a more detailed view of an interface between a confocal laser scanning microscope (CLSM) and a movable stage of FIG. 1, in accordance with the invention.

FIG. 4 illustrates a spatial scanning pattern upon a specimen in accordance with the invention.

FIGS. 5A-5B illustrate a path of stage movement for step-mapping and strip-mapping.

FIG. 6 illustrates a simplified block diagram of an embodiment of a set of electronics that allow interoperation between the confocal scanning head and the XY stage.

### DETAILED DESCRIPTION OF THE INVENTION

FIG. 1 illustrates a block diagram 100 of a system, apparatus and method of an embodiment of an electrical interface between a confocal laser scanning microscope (CLSM) 140 and a movable XY stage 150, also referred to herein as a stage 150. As shown, a computer 110 including expansion slots and various (hardware) components that electrically interface with other parts of the computer via a system bus. The hardware components, and software stored within memory and the system bus being located within the computer chassis (not shown here).

A confocal laser scanning microscope (CLSM) interface board 120 is a component that is designed to electrically interface with a confocal laser scanning microscope (CLSM) 140. A stage controller board 130 is a component that is designed to electrically interface with stage 150. The XY stage 150 is designed to move within the confines of a two dimensional XY plane, defined by the X and Y axes, while physically contacting and supporting a specimen from gravity. The specimen is typically a portion of tissue including cellular structures within it. However, a specimen is not limited to being composed of living and/or prior living material, and can be partially or entirely composed of non-living and/or never living material. A mechanical stand

(not shown) is employed to position the CLSM **140** and to support the CLSM **140** from gravity as it is disposed above and directed towards the stage **150**.

The two dimensional XY plane, also referred to herein as a XY plane, is defined by two orthogonal directions referred to herein as the X axis and the Y axis (See FIG. 2), which are also referred to herein as the X direction and the Y direction, respectively. This plane is oriented substantially parallel to the surface of the earth, and being substantially perpendicular to the direction of gravity. As referred to herein, a Z axis, which is also referred to herein as a Z direction, is defined to be substantially parallel to the direction of gravity and perpendicular to the two dimensional XY plane.

In some embodiments, a Marzhauser Scan Plus IM 120× 80—part number 00-24-579-0000 is employed as an XY stage, and a Marzhauser Tango PCIe Stage Controller—part number 00-76-150-0812, is employed as a stage controller. The stage is moved by stepper motors that are controlled by the Marzhauser Tango PCIe Stage Controller. In other embodiments, the stage is a ProScan motorized stage manufactured by Prior Scientific, for example, part number H101CNLI.

The confocal laser scanning microscope (CLSM) **140** is designed to provide images generated from an optical scan via a focused point illumination (laser) towards a two-dimensional plane, within a specimen. The two-dimensional plane coincides with a location of a thin layer of tissue that is intended to be optically scanned within the specimen. This thin layer of tissue can be as thin as a micron or less in thickness.

A light-sensitive detector is employed in combination with a pin hole that is located in the optically conjugate focal plane. The optically conjugate focal plane is disposed at a location in space in accordance with a location of the two-dimensional plane and the layer to be optically scanned within the specimen.

FIG. 2 illustrates a block diagram **200** of some of the internal components of an embodiment of a confocal laser scanning microscope (CLSM) **140**. As shown, the CLSM **140** includes a laser module **210**, beam splitter **212**, fast scanning mirror **214**, slow scanning mirror **216** and galvanometer **218**. The laser module generates a laser beam (not shown) that passes through the beam splitter **212** and on the return path it is reflected by the beam splitter towards the detector.

A first of these two beams first reflects off of the fast scanning mirror **214** then reflects off of the slow scanning mirror **216** in route to being directed towards a specimen **238**. Prior to arriving at the specimen **238**, the laser beam passes through a telescope **230**, a wave plate **232**, an objective lens **234** and a window **236** portion of the CLSM **140**.

The window **236** is made from a ridged and translucent material. Such material is attached to the scan head and/or attached to a slide holding the specimen **238** itself. An index matching fluid is disposed adjacent to the window **236** for the purpose of optical refractive index matching. Such fluid can be an oil, gel, water or in some circumstances, air.

The fast scanning mirror **214** oscillates horizontally between two extreme positions and along a direction that is substantially parallel to the X axis **260**, while the slow scanning mirror **216** moves along a direction that is substantially parallel to the Y axis. Via the oscillation of the fast scanning mirror **214** between two extreme positions, a direction of the laser beam oscillates between two extreme directions.

A galvanometer **218** is employed to control the movement of the slow scanning mirror **216**. The galvanometer **218** is also referred to herein as a “galvo”, and is an electro-mechanical instrument that is designed to move precisely in response to receiving an electrical signal. The CLSM **140** further includes a resonant scanner **220** component which is employed to cause oscillating movement of the fast scanning mirror **214**.

The CLSM **140** further includes a telescope **230**, which is designed to pass light and which includes one or more lenses (not shown). The CLSM **140** further includes a wave plate **232** and objective lens **234** and a window **236**. The window **236** passes light towards the specimen **238** and receives light that is reflected off of a specimen **238** and back into the CLSM **140**.

Light reflecting off the specimen **238** passes through the window **236**, the objective lens **234**, the wave plate **232**, the telescope **230**, and is reflected by the beam splitter **212** through a detector module input lens **242** into a detector module **240**. The detector module **240** is designed to process light that is received through a light input aperture, which is also referred to herein as a “pin hole”.

The pin hole of the detector module **242** is positioned to receive light that is reflected off a scanning plane that is located within the specimen **238**. Such light that is reflected off of the scanning plane, referred to here as reflected light, is captured along an optical focal plane, having a particular location in three dimensional space, and that is associated with that particular scanning plane within the specimen **238**.

Typically, an internal portion of the specimen **238** is optically scanned along a scanning plane that is located at particular depth (distance) within the specimen, as measured from an outer surface of the specimen **238** that is nearest to the CLSM **140**. This outer surface is typically a highest elevated (upper) surface of the specimen, considering that the CLSM **140** is typically disposed at a higher elevation above the specimen **238**.

A plurality of scanning planes are located within a three dimensional space that is occupied by the specimen **238**. Each of a plurality of scanning planes is oriented perpendicular to the Z direction and layered (stacked) together along the Z direction within the specimen **238**. Each of these scanning planes is associated with a particular focal plane. The detector module **242** is designed to input light reflected from each scanning plane. Via the detector module, a three dimensional image of at least a portion of the specimen **238**, or optionally of the entire specimen, is stored into a memory as digital data.

In accordance with some embodiments of the invention, a version of the CLSM **140** of FIG. 2 is employed where in certain mode of operation, movement of the slow scanning mirror **216** is substituted for by a moving XY stage, while the fast scanning mirror **214** continues to move in an oscillating fashion.

FIG. 3 illustrates a view of an embodiment of the invention, being a confocal scanning system, that includes a confocal scan head (CSH) **340** which functions as a laser scanning microscope (CLSM) **140** and that includes a movable stage, like that of FIG. 1. As shown in this embodiment of the invention, much of the functionality of the CLSM **140** is packaged into a confocal scan head (CSH) **340**. The confocal scan head (CSH) **340** is disposed at a higher elevation relative to the XY stage **150**, and functions as a computer separate from the computer **110** of FIG. 1. The system control component **362** of the CSH **340** includes a micro-controller and other hardware and software components.

## 5

Unlike the CLSM of FIG. 2, in some modes of operation, referred to herein as strip mapping, movement of the slow scanning mirror 216 within the CSH 340 is eliminated, and instead, substituted for by movement of the XY stage 150 in a direction that is substantially parallel to the Y axis, while the fast scanning mirror 214 of the resonant scanner continues to move in an oscillating fashion that is substantially parallel to the X axis 260. In this mode of operation, movement of the XY stage 150 is synchronized with movement of the fast scanning mirror 214.

In other modes of operation, referred to herein as step mapping or block mosaic scanning, the movement of the XY stage 150 supplements that of the movement of the slow scanning mirror 216 and that of the fast scanning mirror 214.

In this embodiment, the software residing within the CSH 340 includes application software which interfaces with various devices via device drivers. These device drivers include a laser driver 342, which interfaces with a laser component that is also located within the CSH 340. A resonant scanner driver 344 interfaces with a resonant scanner which is located within the CSH 340, and a galvanometer driver 346 interfaces with a galvanometer that is located in the CSH 340, and a Z motor driver 348 that interfaces with a Z motor, which is located inside of the CSH 340. The Z motor is designed to move (raise or lower) the CSH 340 along a direction that is parallel to the Z axis 280.

The CSH 340 also includes a detector module 360, system control hardware 362, and an objective lens 354. Like the detector module of FIG. 2, the detector module 360 of FIG. 3 is designed to input light reflected from each focal plane that is associated with a scanning plane within the specimen 238 (See FIG. 2) that is disposed onto the XY stage 150.

Via the detector module 360, data representing a three dimensional image of at least a portion of the specimen 238 is stored into a memory as digital data. In some embodiments, the data is temporarily stored in memory within the CSH 340 and communicated to another memory that is located outside of the CSH 340, such as stored into memory inside of the computer 110, and communicated via the scan head interface communication channel 364. In other embodiments, the data is communicated directly from the CSH 340 to memory stored inside of the computer 110, via the scan head interface communication channel 364.

Electronics within the system of the invention obtains information regarding the real-time movement of the resonant scanner 220 and in response, the system converts the real-time movement of the resonant scanner 220 into a series of one or more commands, that are communicated from confocal laser scanning microscope (CLSM) application software 370 to the stage controller board 130, via a stage controller motor cable 368.

These commands direct the Stage Controller Board 130 to adjust the velocity of movement of the moving XY stage 150, if necessary, in accordance with the real-time frequency of movement of the resonant scanner 220, which typically varies over time. Such frequency of movement changes can occur in response to changes in a temperature of the resonant scanner 220. In response, the Stage Controller Board 130 communicates and controls the movement of the XY stage 150 via a stage controller motor cable 368.

As shown, the computer 110 includes various user interface components, including a user interface monitor (screen), a keyboard and a mouse (user interface pointing device), and a joystick. A user can employ the computer to position the confocal scan head (CSH) 340 and position the XY stage 150, before or after initiation of scanning by the confocal scanning system. Also, laser power can be adjusted

## 6

to adjust image brightness. The stage 150 can be moved below CSH to align specimen into a desired position.

The computer 110 executes confocal laser scanning microscope (CLSM) application software which is designed to receive and process inputs from the user interface components, and designed to interface with and interoperate with other components that are in electrical communication with the computer 110, including such as the scan head interface board 120 and the stage controller board 130.

FIG. 4 illustrates a spatial scanning pattern upon a specimen 238 representing an interoperation between the resonant scanner of the confocal scan head CSH 340 and the moving XY stage 150, in accordance with the invention. As shown, a cross-section of a specimen 238 includes a cross-section of a volume of interest 410, being a layer of tissue within the specimen 238. This layer 410 constitutes a subset of the tissue that is located within the specimen 238. This layer 410 has an upper (most elevated) boundary and a lower (least elevated) boundary that are each planar in shape and parallel to X axis 260 and the Y axis 270. A scanning plane is defined to be a plane in three dimensional space that is oriented parallel to each of the lower and upper boundaries of the layer 410 and that is targeted to reside half way between the upper and lower boundaries of the layer 410. Essentially, the scanning plane is centered with respect to a center elevation of the layer 410 and it is a plane that is located in three dimensional space and within the specimen 238. This scanning plane is a plane along which the optical scanning of the CSH 340 is focused.

A circular shaped portion of a scanning plane that intersects a laser beam that is projected from the CSH 340 is referred to herein as an airy disk (AD) 420. An airy disk 420 is also referred to herein as a laser beam cross-section. This AD 420 represents an area upon which light reflects from the specimen 238 and passes into the light input aperture of the detector module 240. The airy disk 420 moves (oscillates) horizontally (left to right) along the X axis 260, while the XY stage 150 moves the specimen 238 vertically along the Y axis. The CSH 340 (not shown here) is located above (at a higher elevation than) the scanning plane that is located within the specimen 238, and above the specimen itself 238.

Due to the vertical (northerly) movement of the XY stage 150 along the Y axis 270, the horizontal movement of the AD 420 is slanted over time while moving from left to right and from right to left, along the scanning plane and through a cross-section of the specimen 238. As a result, such movement creates a zig-zag like pattern along the scanning plane which passes through a cross-section of the specimen 238.

In accordance with the invention, to scan an entire volume of interest (layer), without missing scanning of a particular location within the volume of interest (layer), movement of the XY stage 150 is controlled to create an intentional overlap between adjacent scan paths along the scanning plane, despite such scan paths moving in a zig-zag like pattern along the scanning plane.

For example, a first segment of a scan path (scan path segment) is defined as residing between airy disk (AD) location at 420a and 420b, and a second scan path segment is defined as being located between AD location 420b and 420c. Notice that the first scan path segment and the second scan path segment overlap each other. The minimum amount of overlap between these two scan path segments is the overlap between the AD at location 420a and 420c. As shown, the overlap between the AD at location 420a and 420c is about 12 percent.

Note that in some embodiments of the invention, optical scanning occurs with movement of the AD **420** in a direction from left to right, but does not occur in with movement of the AD **420** in a direction from right to left. In other embodiments, optical scanning occurs in both directions.

The maximum overlap between scan path segments occurs just prior to when the AD arrives at location **420b** and just after it departs from location **420b** and travels towards location **420c**. In this vicinity of **420b**, there is nearly a 100% overlap between the arriving and departing AD **420**. However, the overlap reduces to about a 12% between when the AD **420** arrives at location **420c** in relation to when the AD **420** departed location **420a**.

In some embodiments, each pixel within a scan line is defined to be a center portion of each uniquely located airy disk **420**. The span of airy disk itself can cause overlap between adjacent scan lines. Essentially, a center portion of each airy disk can be carved out to define a pixel within that airy disk **420**, while a remaining portion of an AD **420** can be discarded.

In other words, a center portion of an airy disk is referred to herein as a pixel. Within these embodiments, such a center portion is defined to be square in shape and is referred to as a square pixel. A required overlap between scan line segments depends upon a relative size between the center portion of the AD and the overall dimensions of the entire AD **420**. As a result, some embodiments may require much more than 12% overlap, for example as much as a 50% overlap or more, between adjacent scan path segments to capture and join each and every pixel (center portion) of each AD **420** that resides within the scanning plane of interest.

Note that the XY stage **150** moves in one direction while the resonant scanner mirror oscillates in a direction that is perpendicular to the direction of movement of the XY stage **150**. Such movement between the XY stage **150** and resonant scanner takes place over a rectangular area, the span of which defines a frame. A frame is typically a rectangular area having a width that is less than or equal to the horizontal span of the movement of the resonant scanner mirror. The frame having a height that is less than or equal to the span of movement of the XY stage **150**.

FIGS. **5A-5B** each illustrate a path of stage movement for respectively performing step mapping and strip mapping. FIG. **5A** illustrates step mapping, which is also referred to herein as block mosaic mapping or scanning Referring to FIG. **5A**, a frame **510a**, being a portion of a scanning plane residing along a cross-section of a volume of interest within a specimen **238**, is first scanned. The scanning of frame **510a** initiates with an aim of the CSH **340** directed towards a center of the frame **510a**, while the resonant scanner fast mirror oscillates between a left hand (western) boundary to a right hand (eastern) boundary of the frame **510a**, and while the slow mirror moves vertically moves through the frame **510a** so that the aim of the laser of the CSH **340** continuously covers from the upper (northern) boundary to a lower (southern) boundary of the frame **510a**, and between the left hand (western) boundary and the right hand (eastern) boundary of the frame **510a**, and until scanning of the frame **510a** is complete.

Upon completion of the scanning of frame **510a**, the XY stage **150** is moved from frame **510a** to frame **510b**, so that the scanning of frame **510b** can be initiated and performed in the same manner as described for frame **510a**.

The scanning of the (16) frames **510a** through **510p** are performed in lexicographic (alphabetic) order over time, meaning in the order of **510a**, **510b**, **510c** . . . **510p**. The

frames **510a** through frame **510p** constitute one continuous scanning plane along cross-section of interest within the specimen **238**. Tissue within about 1 micron below this scanning plane is referred to as a layer of interest.

It is preferred that there is optical scanning overlap among the (16) frames **510a-510p** that are adjacent to each other. This overlap is employed to join (stitch) frames together to form a joined (unified) optical scanning image including all of the (16) frames **510a-510p**. In other embodiments, there may be no overlap between scanned data, such as between the frames, when scanning via step mapping.

In some embodiments, image joining software is implemented using an OpenCV open source library of programming functions. The OpenCV functions are employed to identify like image patterns within adjacently scanned image data, for use as markers for deciding how to align and join together adjacently scanned image data. Such software can join adjacent scanned frames within a same layer, and/or join adjacent frames within separate but adjacent scanned layers.

Such image patterns can be caused by particular cells reflecting light that is directed towards those cells and that within particular wavelength ranges. In some circumstances, injection of various dyes into a layer of the specimen **238** can cause cells within that portion of the specimen **238** to fluoresce, meaning those cells to shine or glow brightly due to fluorescence of the cell that is caused contact between the dye and the cell.

FIG. **5B** illustrates strip mapping, which is also referred to herein as strip scanning Referring to FIG. **5B**, a frame **510q**, having a longer vertical (north/south) dimension relative to its horizontal (west/east) dimension, is also referred to herein as a scanning strip or strip. This strip is **510q** resides along a scanning plane that is a cross-section of a volume of interest within the specimen **238**. The scanning of frame **510q** initiates at a lower (southern) boundary of frame **510q**, while the resonant scanner mirror of the SCH **340** oscillates between a left (western) hand boundary and a right (eastern) hand boundary of the frame **510q**, and while the XY stage **150** moves so that the aim of the confocal scan head (CSH) **340** continuously moves from a lower (southern) boundary of the frame **510q** to an upper (northern) boundary of the frame **510q**, in order to complete scanning of the entire frame **510q**.

The XY stage **150** then moves so that the aim of the CSH **340** is moved outside of any frame (strip) **510q-510t**, and then moving from a right hand (eastern) location to a left hand (western) location, while passing through location **520c**, which is outside of any frame **510q-510t**, and then moving towards location **520d**, inside of frame **510r**, in order to initiate scanning of frame **510r**. The scanning of frame **510r** initiates at an upper (northern) boundary, while the resonant scanner mirror oscillates between a left hand (western) boundary and a right hand (eastern) boundary of the frame **510r**, while the XY stage **150** moves so that the aim of the confocal scan head (CSH) **340** continuously moves between an upper (northern) boundary and a lower (southern) boundary of the frame **510r**, in order to complete scanning of the frame **510r**.

The XY stage **150** then moves so that the aim of the CSH **340** is moved outside of any frame **510q-510t**, and then moving from a right hand (eastern) location to a left hand (western) location, while passing through location **520f**, which is outside of any frame **510q-510t**, and then moving towards location **520g**, which is inside of frame **510s**, in order to initiate scanning of frame **510s**.

Frame **510s** is then scanned in the same manner as described herein for frame **510q**. After scanning frame **510s**,

frame **510t** is scanned in the same manner as described herein for frame **510r**. As shown, frames **510q-510t**, each have a long rectangular shape, as opposed to having a square shape, like the frames **510a-510p**, of FIG. 5A.

As with adjacent frames, software is employed to join adjacent scanned strips of image data. Such software can join adjacent strips within a same scanned layer, and/or join adjacent strips within separate but adjacent scanned layers.

FIG. 6 illustrates a simplified block diagram of an embodiment of a set of electronics that allow interoperation between the confocal scanning head **340** and the XY stage **150**.

As shown, driver electronics (hardware), a Texas Instruments model DRV8801 **610**, also referred to as the resonant scanner driver (RSD) component, outputs an electronic signal to a resonant scanner manufactured by Cambridge Technology (Model CRS 8 KHz) **612**. The resonant scanner outputs an analog electronic signal, referred to herein as a resonating signal (labeled as "Fdbk Velocity" or "Vel fdbk"), is called a feedback velocity signal **614**. This feedback velocity signal which represents the movement of the resonant scanner in real-time, meaning that this signal is generated synchronously (near simultaneously) with each physical movement of the resonant scanner within the CSH **340**, while it is resonating over time.

A frequency of the resonating signal represents a frequency of resonance of the resonant scanner over time. Because the frequency of a resonating scanner typically changes over time, typically in response to a change in temperature, the frequency of the resonating feedback velocity signal, accordingly changes over time. The amplitude of the resonating feedback velocity signal, at a particular time, represents a location within the scan angle of the resonant scanner where the resonant scanner is directed, at that time. The direction of the resonant scanner oscillates within a range of resonating (oscillating) motion. A maximum amplitude and minimum amplitude of the resonating signal each represent a maximum swing (oscillation) of the laser of the resonant scanner, within its range of resonating (oscillating) motion.

The resonating signal output from the resonant scanner and input into an analog to digital converter (ADC) **616**. The ADC **616** outputs a first series of digital values over time. The first series of digital values is input into Averager component **618**, which outputs a second series of digital values which represent an averaging of segments of the first series of digital values, for the purpose of reducing noise within the signal. In some embodiments, every (4) consecutive values within the first series is averaged into (1) value of the second series of digital values.

The Averager component **618** outputs the second series of digital values into a Filter component **620**, which processes those values being input from the Averager **618** to determine an amplitude and a phase of the resonating signal over time. The Filter component **620** outputs a first digital signal (amplitude signal), which represents an amplitude of the resonating signal over time, and outputs a second digital signal (phase signal), which represents a phase of the resonating signal over time.

The amplitude signal **622** is input to the Amplitude Controller **624** from the Filter component **620**. The amplitude signal **622** is employed as a feedback signal to the Amplitude Controller **624** in order to monitor and adjust the physical range movement of the resonating scanner **612**. The Amplitude Controller **624** outputs a pulse width value signal **626** to a Pulse Width Modulator (PWM) component **628** which causes the PWM **628** to output a signal **630** to the

resonant scanner driver (RSD) component **610**, to adjust, if necessary, the physical range of movement of the resonating scanner **612**.

The phase signal **642** is input to the Frequency Controller **644** from the Filter component **620**. The phase signal **642** is employed as a feedback signal to the Frequency Controller **644** to monitor and adjust the physical frequency of movement of the resonating scanner **612**. The Frequency Controller **644** outputs a frequency adjust value signal **646** to a Direct Digital Frequency Synthesizer (DDFS) **648** which causes the DDFS **648** to output a first signal **650** to the resonant scanner driver (RSD) component **610**, to inform the RSD **610** of the actual frequency of physical movement of the resonating scanner **612**.

The DDFS **648** outputs a second signal **652** which represents a frequency value which is communicated to the Confocal Laser Scanning Microscope (CLSM) software that executes on the computer **110** (See Page 3). The CLSM software performs an algorithmic computation to convert the frequency value received from the DDFS into a series of one or more commands, that are communicated from the CLSM software to the Stage Controller Board. These commands direct the Stage Controller Board to adjust the velocity of the moving stage, if necessary, in accordance with the current frequency value, and as that current frequency value changes over time.

In some embodiments, when strip mapping, the computation adjusts the velocity of the XY stage **150** at upon completing an optical scan of each strip **510r-510t**.

In a circumstance where the frequency of the resonant scanner **612** remains constant over a period of time, then an appropriate velocity of the XY stage **150** will also remain constant over that period of time, in accordance with the constant frequency value for the resonant scanner.

Also, the velocity of the XY stage **150** is determined to provide some overlap (optical scanning overlap) between horizontal and adjacent scan lines obtained by horizontal (east/west) movement of the field of view, caused by the resonance (horizontal oscillation) of the confocal scanning head (CSH) **340** while the XY stage **150** moves in a vertical (north/south) direction relative to the horizontal oscillation of the resonating scanning head.

In some embodiments, the optical scanning overlap, also referred to herein as a target overlap, is typically about 10% of the vertical height of each scan line. For example, if the vertical height of the field of view (FOV), and consequently of each scan line is equal to 1000 microns, then the target overlap would be about 100 microns in size.

For this embodiment, if hypothetically, the stage velocity is perfectly accurate and constant, then there would be a 100 micron overlap of scanned image between each scan line. This overlap enables the image stitching software, to combine two adjacent scan lines into one coherent and accurate image. Small inaccuracies caused by non-optimal (non-perfect) velocity of the stage can be corrected, at the cost of time for computing, by operation of the stitching software, provided that the inaccuracy does not exceed the size of the actual overlap.

Note that in some embodiments, the stage velocity is set to also enable the scanning of square pixels, which requires the height of each optical scan path to be greater than or equal to a width of each scanned pixel.

In a typical use scenario, the resonant scanner oscillates at a target frequency of 8000 cycles per second. Each pixel has a target width of 0.8 microns. Each horizontal scan line is designed to include 1024 pixels and in combination with the pixel target width, each scan line is approximately (1024

pixels per scan line\*0.8 microns per pixel)=819.2 microns in horizontal width, which is also referred to herein as scan line width.

This scan line width equates to 0.8192 millimeters, yielding a scan line of nearly 1 millimeter in horizontal width. In this scenario, a range of direction of the laser beam projected from the confocal scan head CSH 340 would include aiming at the outer boundaries of scan line, and aiming at the entirety of the scan line between its outer boundaries. Such a range of laser beam aiming direction is said to be within the range of the scan angle of the oscillating laser beam, as it is projected from the CSH 340.

In order to enable scanning of square pixels, the XY stage 150 should move at a target stage velocity of (8000 cycles/sec)\*(0.8 microns height per pixel)=6400 microns per second to accommodate a pixel height equal to 0.8 microns.

However, should the resonant frequency of the resonant scanner vary by a maximum of plus or minus 2 cycles per second, this could alter the target XY stage velocity to a range between 6398.4 microns per second and 6401.4 microns per second.

For example, in response to the varying resonant frequency, the target stage speed would be (7998 cycles per second\*0.8 microns per pixel)=6398.4 microns per second when the resonant scanner frequency drifts down to 7998 cycles per second. Alternatively, the target XY stage speed would be (8002 cycles per second\*0.8 microns per pixel)=6401.4 microns per second when the resonant scanner frequency drifts up to 8002 cycles per second. The target stage velocity is controlled to match the resonant scanner frequency near instantaneously and in real time.

In another use scenario, reduction of optical noise within the optical scanning of the specimen can be reduced by reducing the target XY stage speed by one half. In this scenario, optical scanning of two adjacent scan lines are averaged to reduce optical noise. This technique is said to employ over sampling. This technique can be used to improve upon (increase brightness of) what would otherwise be scanned images that appear dim as seen from a human eye.

In other use scenarios, different operating parameters, such as a different target resonant scanner frequency, different pixel size and pixel shape, and different target XY stage velocity can be employed for various purposes. This written description uses example embodiments to disclose the invention, including the best mode, and also to enable any person skilled in the art to practice the invention, including making and using any devices or systems and performing any incorporated methods. The patentable scope of the invention is defined by the claims, and may include other examples that occur to those skilled in the art. Such other examples are intended to be within the scope of the claims if they have structural elements that do not differ from the literal language of the claims, or if they include equivalent structural elements with insubstantial differences from the literal language of the claims.

## PARTS LIST

110 computer  
120 CLSM interface board  
130 stage controller board  
140 CLSM  
150 XY stage  
210 laser module  
212 beam splitter  
214 fast scanning mirror

216 slow scanning mirror  
218 galvanometer  
220 resonant scanner  
230 telescope  
232 wave plate  
234 objective lens  
236 window  
238 specimen  
240 detector module  
242 detector module input lens  
260 X axis  
270 Y axis  
280 Z axis  
340 confocal scan head  
342 laser driver  
344 resonant scanner driver  
346 galvanometer driver  
348 Z motor driver  
354 objective lens  
360 detector  
362 system control  
364 scan head interface  
366 stage sync signal  
368 stage controller motor cable  
410 layer, volume of interest  
420 airy disk  
420a-e locations of airy disk  
450 north direction  
460 south direction  
470 east direction  
480 west direction  
510 frame  
510a-t locations of different frames  
610 Texas Instruments Driver DRV8801  
612 resonant scanner Cambridge Technology CRS 8 KHz  
614 feedback velocity  
616 analog to digital converter  
618 averager  
620 filter  
622 amplitude signal  
624 amplitude controller  
626 pulse width value  
628 pulse width modulator (PWM)  
630 PWM output signal  
642 phase signal  
644 frequency controller  
646 frequency adjust value  
648 direct digital frequency synthesizer (DDFS)  
650 DDFS output signal  
652 frequency value  
The invention claimed is:  
1. A system for scanning material, comprising:  
a resonant scanner that is configured for optical scanning of a specimen of material, and wherein a direction of said optical scanning is performed within an oscillating pattern that cycles in between two extreme locations that define a line that is substantially parallel to a first axis, and wherein said oscillating pattern includes scan path segments from which images are obtained;  
a stage that is configured to move in at least one direction, said direction being substantially parallel to a second axis that is perpendicular to said first axis, and wherein a velocity of said stage is configured to move at a velocity that is in accordance with control signals that are received by said stage over time; and wherein said velocity is controlled over time in a manner so that said oscillating pattern causes overlap between said

## 13

scan path segments being adjacent to each other and causes overlap between said images obtained from said scan path segments being adjacent to each other; and one or more software components that configured for joining together of said images obtained from a plurality of said scan path segments.

2. The system of claim 1 wherein a set of electronics is configured to obtain a frequency of resonance of said resonant scanner over time, and wherein said set of electronics controls said velocity of said stage over time, via transmission of said control signals in response to said frequency of resonance over time.

3. The system of claim 1 wherein the velocity of said stage is further controlled to enable square pixels to be scanned.

4. The system of claim 1 wherein said velocity of said stage is further controlled to reduce optical noise.

5. The system of claim 1 wherein strips within multiple layers of said specimen are scanned in order to obtain images associated with each of said strips.

6. The system of claim 5 wherein images obtained from adjacent strips within one layer of said specimen are joined together.

7. The system of claim 5 wherein images obtained from adjacent strips within separate and adjacent layers of said specimen are joined together.

8. An apparatus for scanning material, comprising:

a resonant scanner that is configured for optical scanning of a specimen of material, and wherein a direction of said optical scanning is performed within an oscillating pattern that cycles in between two extreme locations that define a line that is substantially parallel to a first axis, and wherein said oscillating pattern includes scan path segments from which images are obtained;

a stage that is configured to move in at least one direction, said direction being substantially parallel to a second axis that is perpendicular to said first axis, and wherein a velocity of said stage is configured to move at a velocity in accordance with control signals that are received by said stage over time; and wherein

said velocity is controlled over time in a manner so that said oscillating pattern causes overlap between said scan path segments being adjacent to each other and causes overlap between said images obtained from said scan path segments being adjacent to each other; and one or more software components that configured for joining together of said images obtained from a plurality of said scan path segments.

9. The apparatus of claim 8 wherein a set of electronics is configured to obtain a frequency of resonance of said resonant scanner over time, and wherein said set of electronics controls said velocity of said stage over time, via transmission of said control signals in response to said frequency of resonance over time.

10. The apparatus of claim 8 wherein the velocity of said stage is further controlled to enable square pixels to be scanned.

## 14

11. The apparatus of claim 8 wherein said velocity of said stage is further controlled to reduce optical noise.

12. The apparatus of claim 8 wherein strips within multiple layers of said specimen are scanned in order to obtain images associated with each of said strips.

13. The apparatus of claim 12 wherein images obtained from adjacent strips within one layer of said specimen are joined together.

14. The apparatus of claim 12 wherein images obtained from adjacent strips within separate and adjacent layers of said specimen are joined together.

15. A method for scanning material, comprising the steps of:

providing a resonant scanner that is configured for optical scanning of a specimen of material, and wherein a direction of said optical scanning is performed within an oscillating pattern that cycles in between two extreme locations that define a line that is substantially parallel to a first axis, and wherein said oscillating pattern includes scan path segments from which images are obtained;

providing a stage that is configured to move in at least one direction, said direction being substantially parallel to a second axis that is perpendicular to said first axis, and wherein a velocity of said stage is configured to move at a velocity in accordance with control signals that are received by said stage over time; and wherein

said velocity is controlled over time in a manner so that said oscillating pattern causes overlap between said scan path segments being adjacent to each other and causes overlap between said images obtained from said scan path segments being adjacent to each other; and providing one or more software components that configured for joining together of said images obtained from a plurality of said scan path segments.

16. The method of claim 15 wherein a set of electronics is configured to obtain a frequency of resonance of said resonant scanner over time, and wherein said set of electronics controls said velocity of said stage over time, via transmission of said control signals in response to said frequency of resonance over time.

17. The method of claim 15 wherein said velocity of said stage is further controlled to reduce optical noise.

18. The method of claim 15 including steps of scanning strips within multiple layers of said specimen in order to obtain images associated with each of said strips.

19. The method of claim 18 wherein images obtained from adjacent strips within one layer of said specimen are joined together.

20. The method of claim 18 wherein images obtained from adjacent strips within separate and adjacent layers of said specimen are joined together.

\* \* \* \* \*