

US010890884B2

(12) **United States Patent**
Kawamoto et al.

(10) **Patent No.: US 10,890,884 B2**
(45) **Date of Patent: Jan. 12, 2021**

(54) **CONTROL DEVICE, CONTROL METHOD, COMPUTER PROGRAM PRODUCT, AND ROBOT CONTROL SYSTEM**

(71) Applicant: **SONY CORPORATION**, Minato-ku (JP)

(72) Inventors: **Kenta Kawamoto**, Tokyo (JP); **Yoshiaki Iwai**, Tokyo (JP); **Satoru Shimizu**, Tokyo (JP)

(73) Assignee: **SONY CORPORATION**, Tokyo (JP)

(*) Notice: Subject to any disclaimer, the term of this patent is extended or adjusted under 35 U.S.C. 154(b) by 0 days.

(21) Appl. No.: **15/675,855**

(22) Filed: **Aug. 14, 2017**

(65) **Prior Publication Data**
US 2018/0011457 A1 Jan. 11, 2018

Related U.S. Application Data
(63) Continuation of application No. 14/234,658, filed as application No. PCT/JP2012/004745 on Jul. 25, 2012, now Pat. No. 9,766,604.

(30) **Foreign Application Priority Data**
Aug. 2, 2011 (JP) 2011-168923

(51) **Int. Cl.**
G05B 15/02 (2006.01)
G05D 1/00 (2006.01)
G06F 3/0484 (2013.01)

(52) **U.S. Cl.**
CPC **G05B 15/02** (2013.01); **G05D 1/0038** (2013.01); **G06F 3/04842** (2013.01);
(Continued)

(58) **Field of Classification Search**
CPC Y10S 901/01; G05B 2219/40099; G05B 2219/40123; G05B 2219/40409;
(Continued)

(56) **References Cited**
U.S. PATENT DOCUMENTS
8,736,228 B1* 5/2014 Freed H02J 7/0044 320/115
2005/0057689 A1 3/2005 Sakagami
(Continued)

FOREIGN PATENT DOCUMENTS
EP 2 263 837 A1 12/2010
JP 2002-219677 A 8/2002
(Continued)

OTHER PUBLICATIONS
Japanese Office Action dated Jun. 30, 2015 in Patent Application No. 2011-168923 (without English Translation).
(Continued)

Primary Examiner — Phuong H Nguyen
(74) *Attorney, Agent, or Firm* — Xsensus, LLP

(57) **ABSTRACT**
A control system, method and computer program product cooperate to assist control for an autonomous robot. The system includes a communications interface that exchanges information with the autonomous robot. A user interface displays a scene of a location in which the autonomous robot is positioned, and also receives an indication of a user selection of a user selected area within the scene. The communications interface transmits an indication of said user selected area to the autonomous robot for further processing of the area by said autonomous robot.

10 Claims, 47 Drawing Sheets

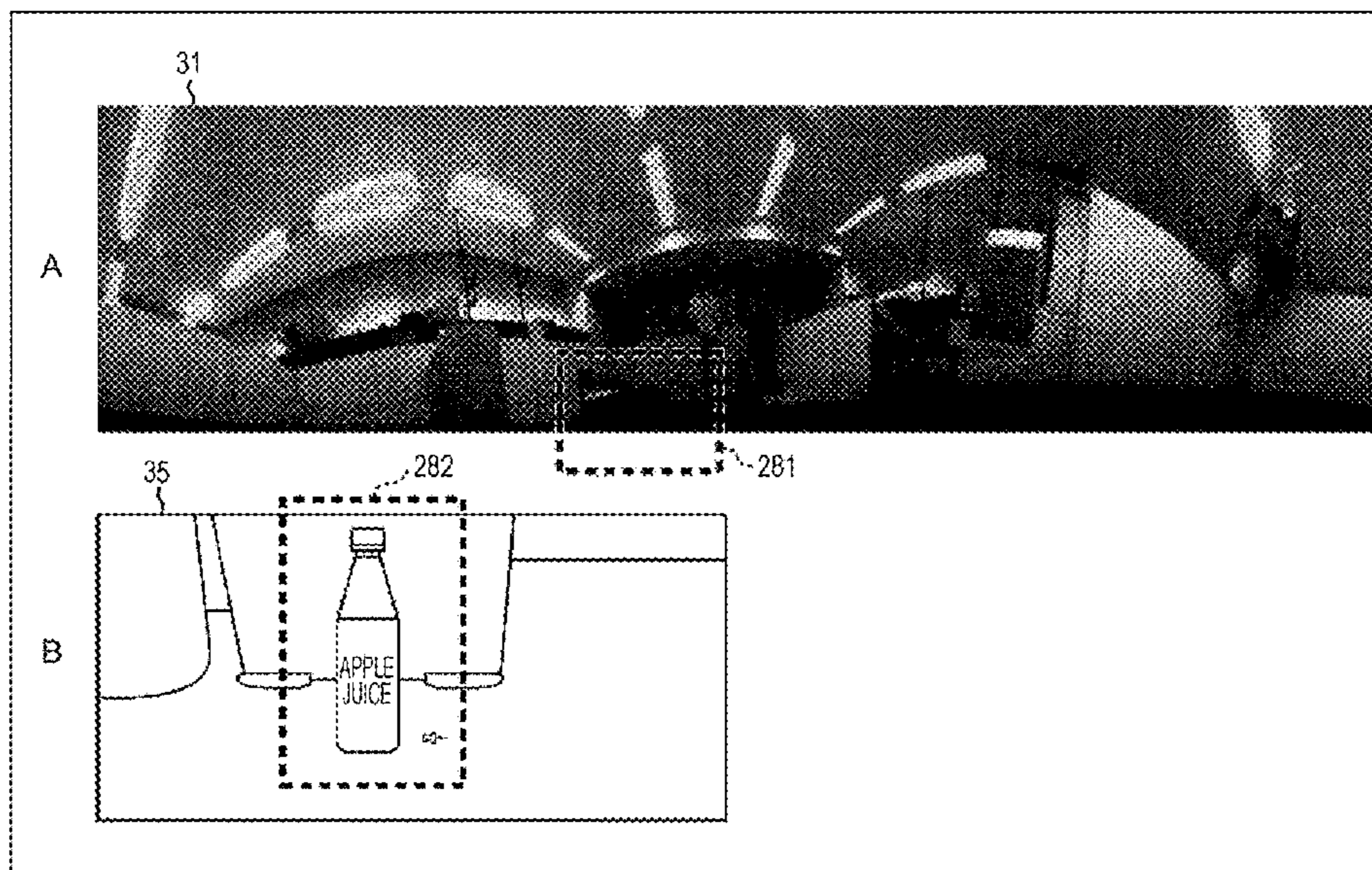

(52) **U.S. Cl.**
 CPC G05B 2219/40099 (2013.01); G05B
 2219/40123 (2013.01); G05B 2219/40409
 (2013.01); G05B 2219/40411 (2013.01); G05D
 2201/0217 (2013.01)

(58) **Field of Classification Search**
 CPC G05B 2219/40411; G05B 2219/39168;
 G05B 2219/23258; G05B 2219/40202;
 G05B 15/02; G05B 2219/31305; G05B
 2219/40478; G05B 2219/40479; G05B
 2219/36017; G06F 3/04842; G05D
 1/0038; G05D 2201/0217

See application file for complete search history.

| | | | |
|----|-------------|---|---------|
| JP | 2005-205529 | A | 8/2005 |
| JP | 2006-113858 | A | 4/2006 |
| JP | 2006-139525 | A | 6/2006 |
| JP | 2007-111854 | A | 5/2007 |
| JP | 2008-68348 | A | 3/2008 |
| JP | 2009-031992 | A | 2/2009 |
| JP | 2009-181222 | A | 8/2009 |
| JP | 2009-214212 | A | 9/2009 |
| JP | 2009-531184 | A | 9/2009 |
| JP | 2009-223172 | A | 10/2009 |
| JP | 2010-264533 | A | 11/2010 |
| JP | 2011-022700 | A | 2/2011 |
| JP | 2011-101915 | A | 5/2011 |
| JP | 2011-108156 | A | 6/2011 |

(56) **References Cited**

U.S. PATENT DOCUMENTS

| | | | |
|--------------|-----|---------|--------------------------------------|
| 2006/0112034 | A1 | 5/2006 | Okamoto et al. |
| 2009/0087029 | A1 | 4/2009 | Coleman et al. |
| 2010/0172733 | A1* | 7/2010 | Chalubert A61F 4/00 414/730 |
| 2010/0298977 | A1* | 11/2010 | Fahn G05D 1/0246 700/259 |
| 2011/0010009 | A1 | 1/2011 | Saito |
| 2011/0109549 | A1 | 5/2011 | Robbins et al. |
| 2011/0128288 | A1 | 6/2011 | Petrou |
| 2012/0072023 | A1* | 3/2012 | Ota B25J 9/1664 700/259 |

FOREIGN PATENT DOCUMENTS

| | | | |
|----|-------------|---|---------|
| JP | 2002-283261 | A | 10/2002 |
| JP | 2003-345435 | A | 12/2003 |
| JP | 2004-268148 | A | 9/2004 |

OTHER PUBLICATIONS

Asako Kanazaki et al., "Fast Object Detection for Robots in a Cluttered Indoor Environment Using Integral 3D Feature Table", 2011 IEEE International Conference on Robotics and Automation, May 9-13, 2011, pp. 4026-4033.

Muhammad Attamimi et al., "Learning Novel Objects Using Out-of-Vocabulary Word Segmentation and Object Extraction for Home Assistant Robots", 2010 IEEE International Conference on Robotics and Automation, May 3-8, 2010, pp. 745-750.

International Search Report dated Nov. 6, 2012 in PCT/JP2012/004745.

Office Action issued in Japanese Patent Application No. 2016-037023 dated Jan. 31, 2017.

Combined Chinese Office Action and Search Report dated Feb. 27, 2015 in Patent Application No. 201280036997.5 (with English language translation).

Office Action issued in Japanese Application 2018-136594 dated Jul. 25, 2019.

* cited by examiner

FIG. 1

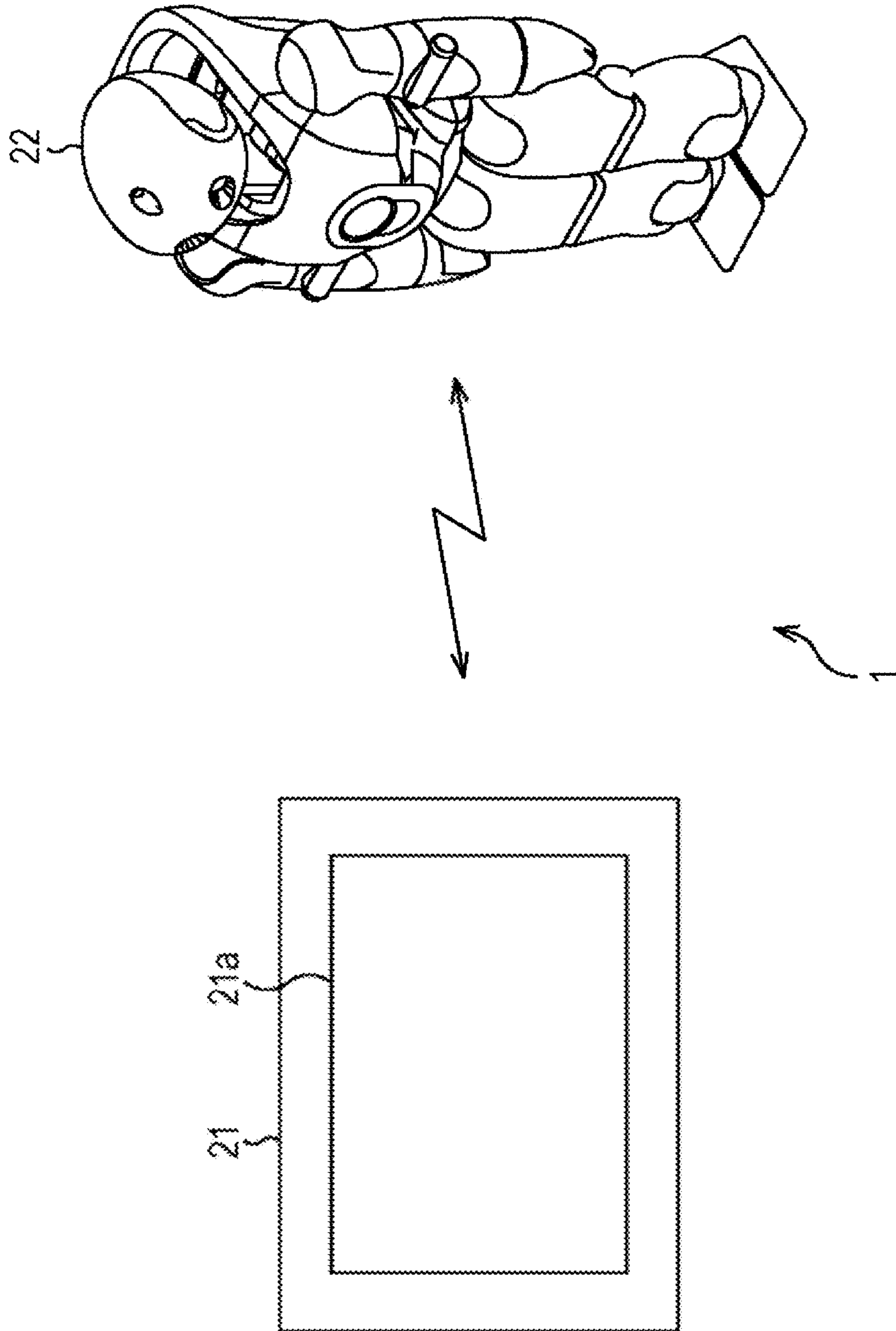

FIG. 2

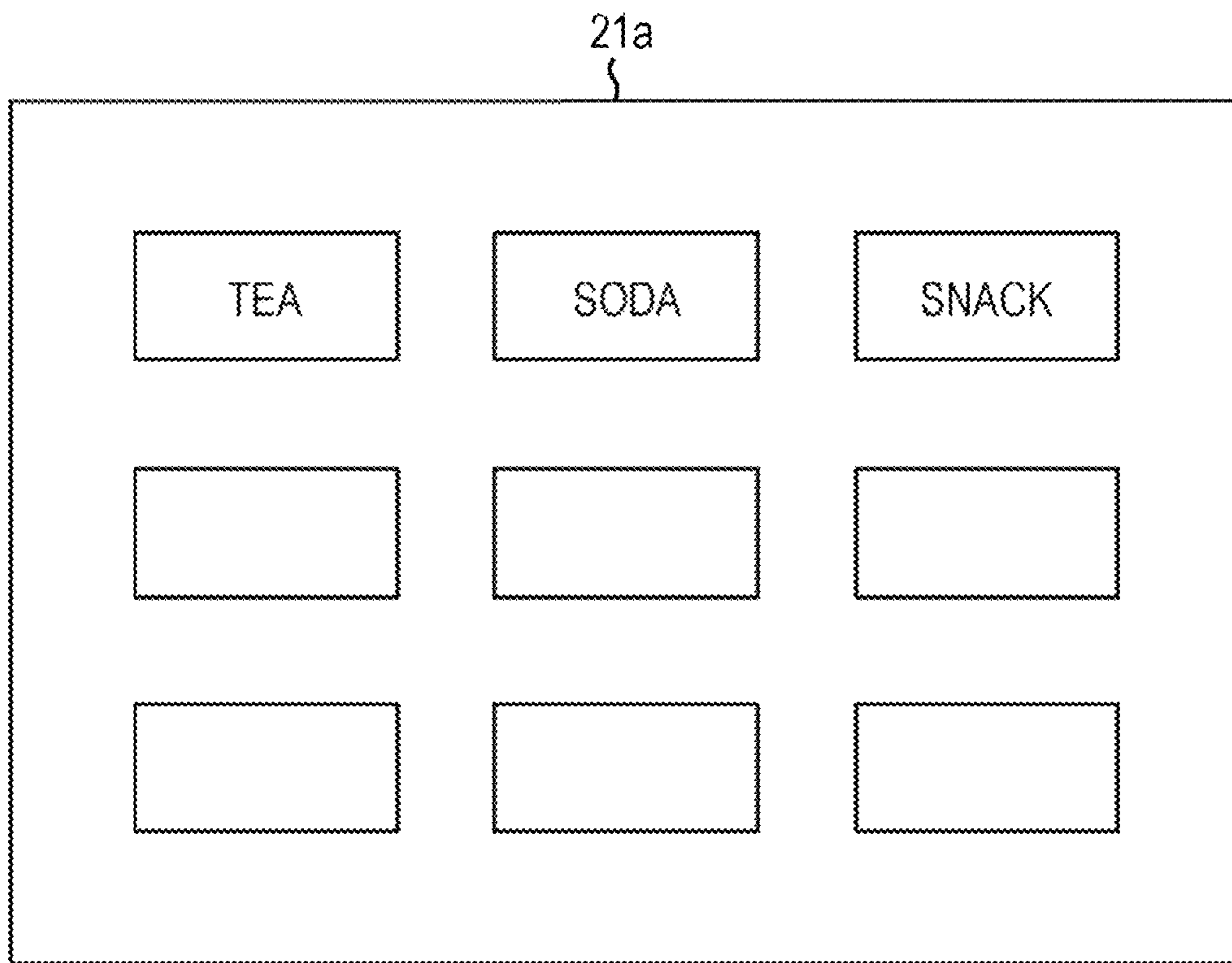

FIG. 3

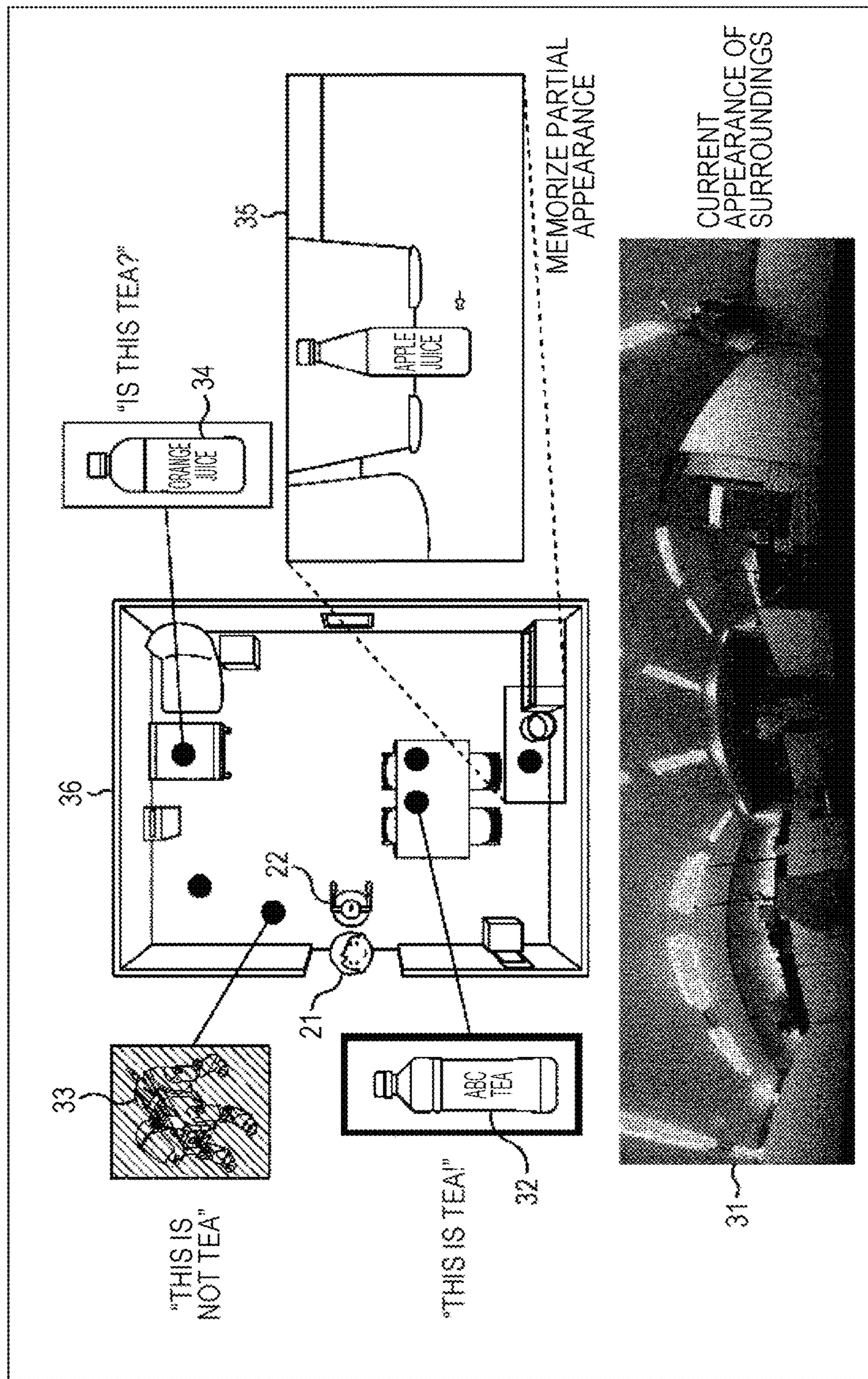

FIG. 4

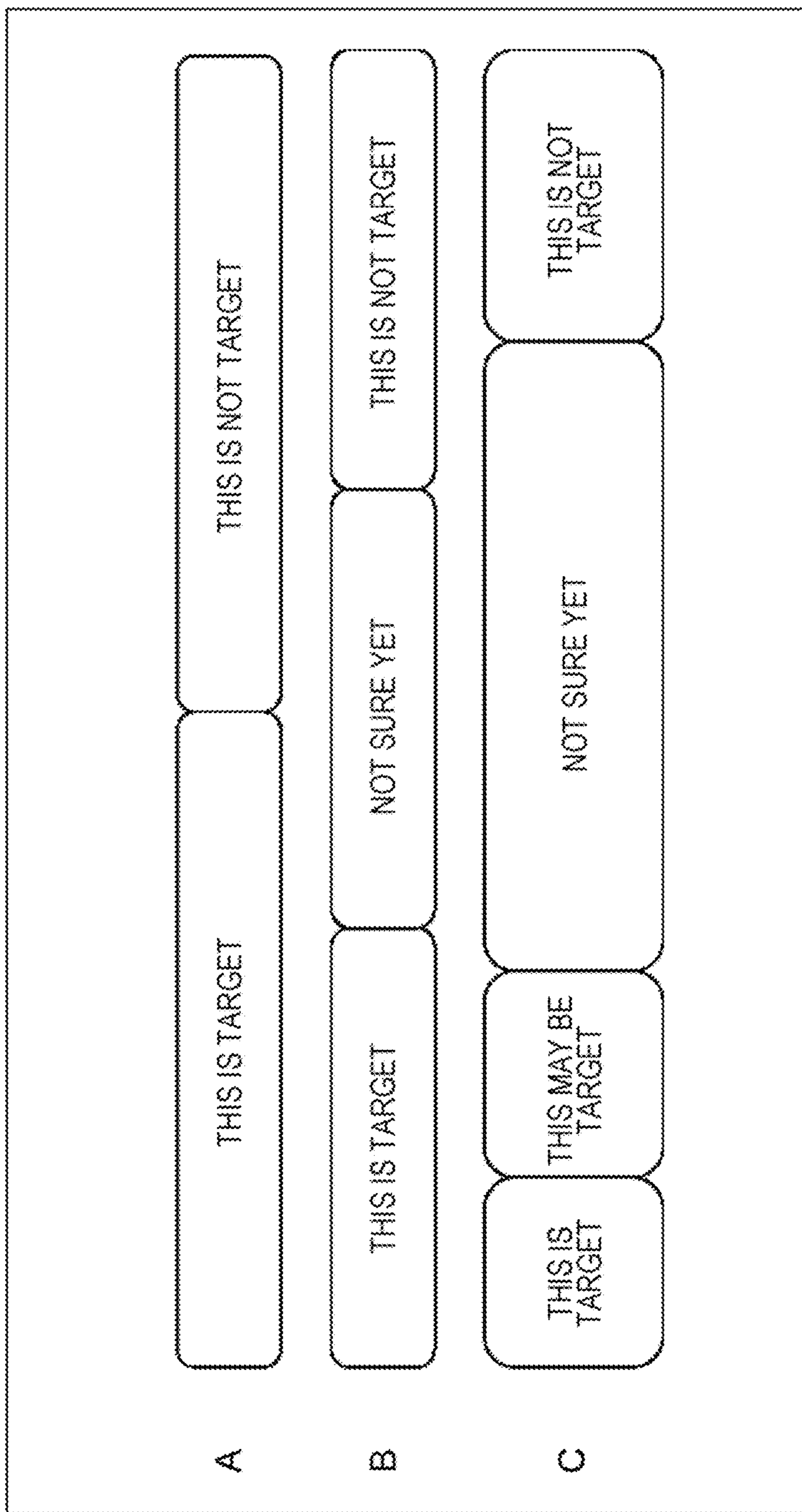

FIG. 5

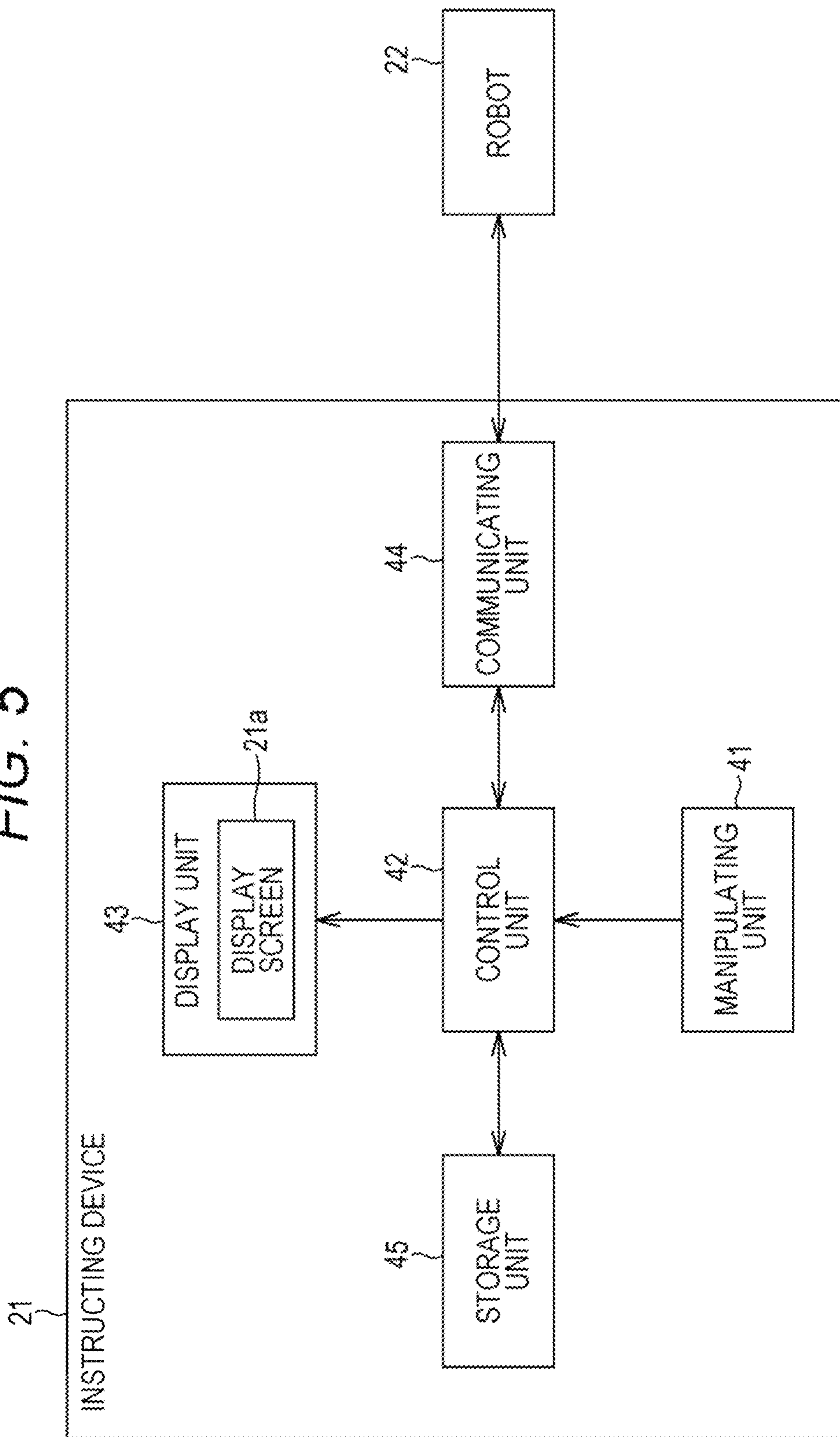

FIG. 6

21a

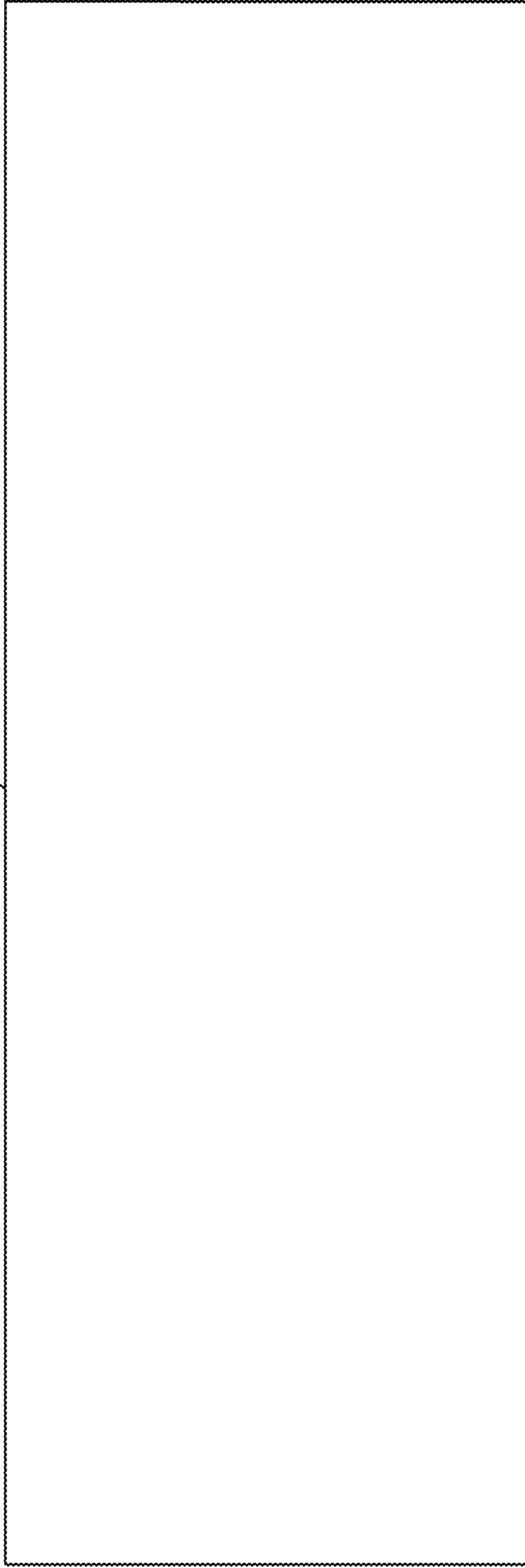

FIG. 7

21a

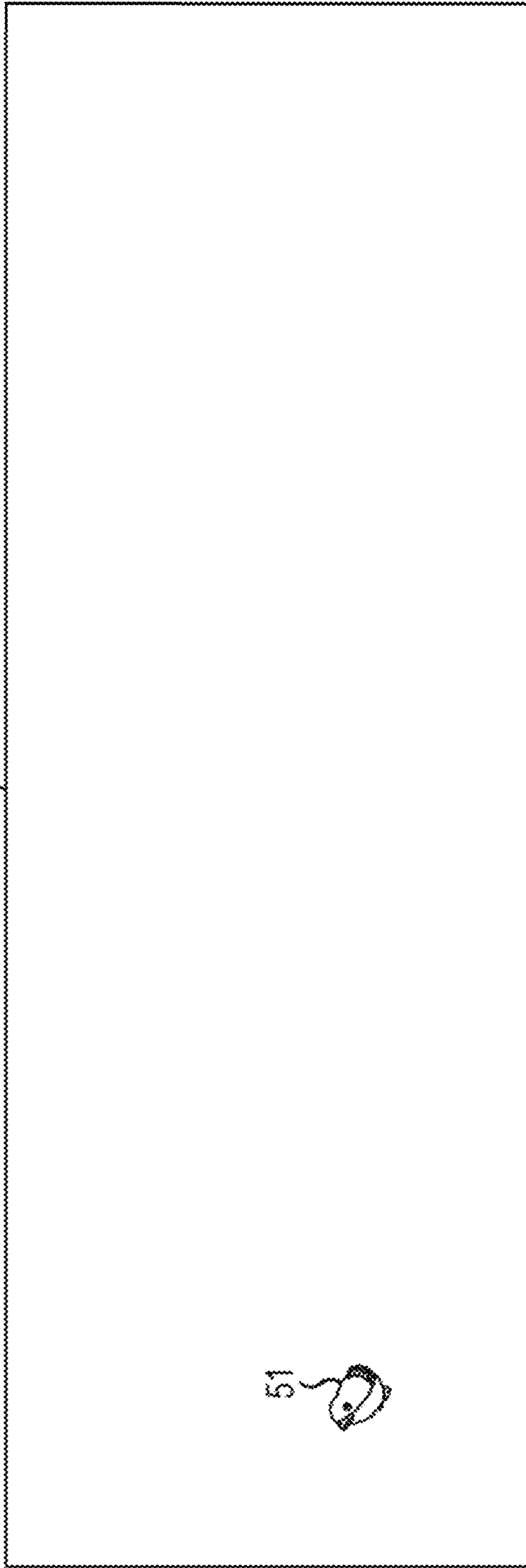
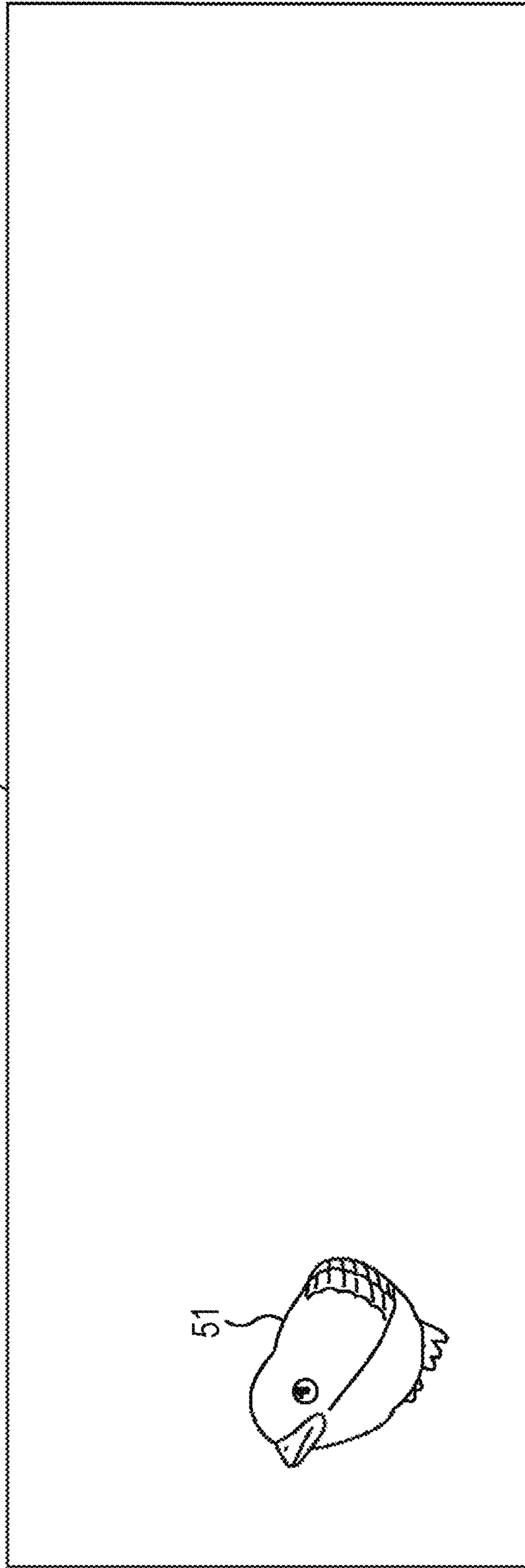

FIG. 8

21a



51

FIG. 9

21a



FIG. 10

21a

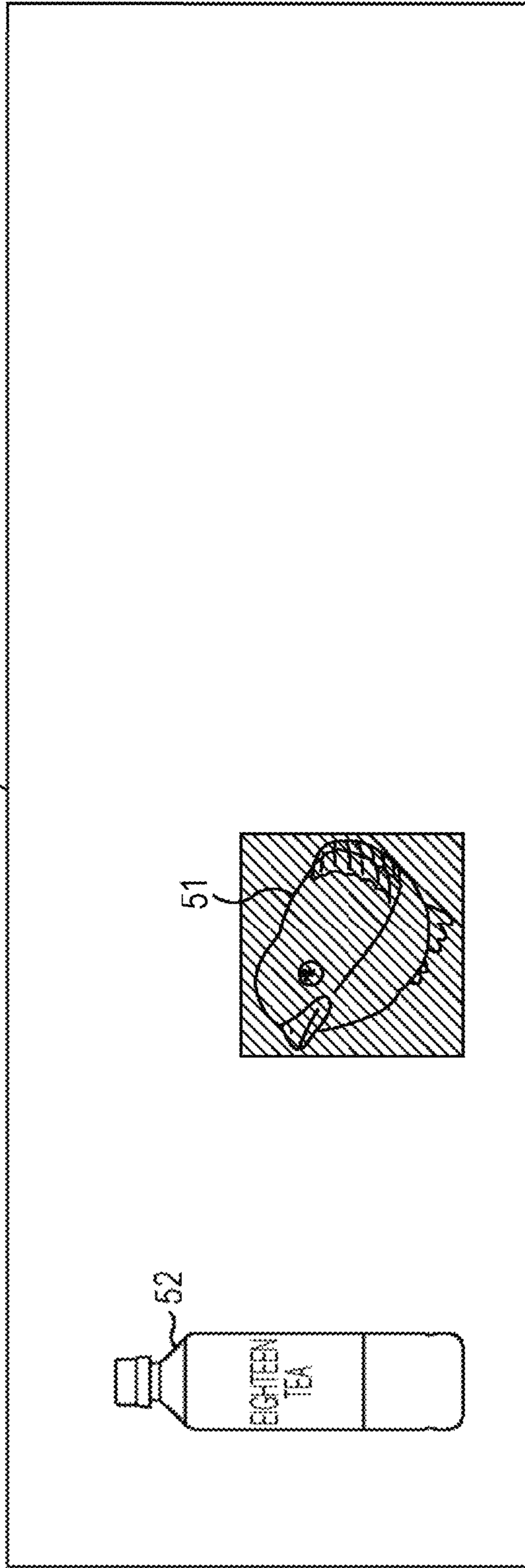

FIG. 11

21a

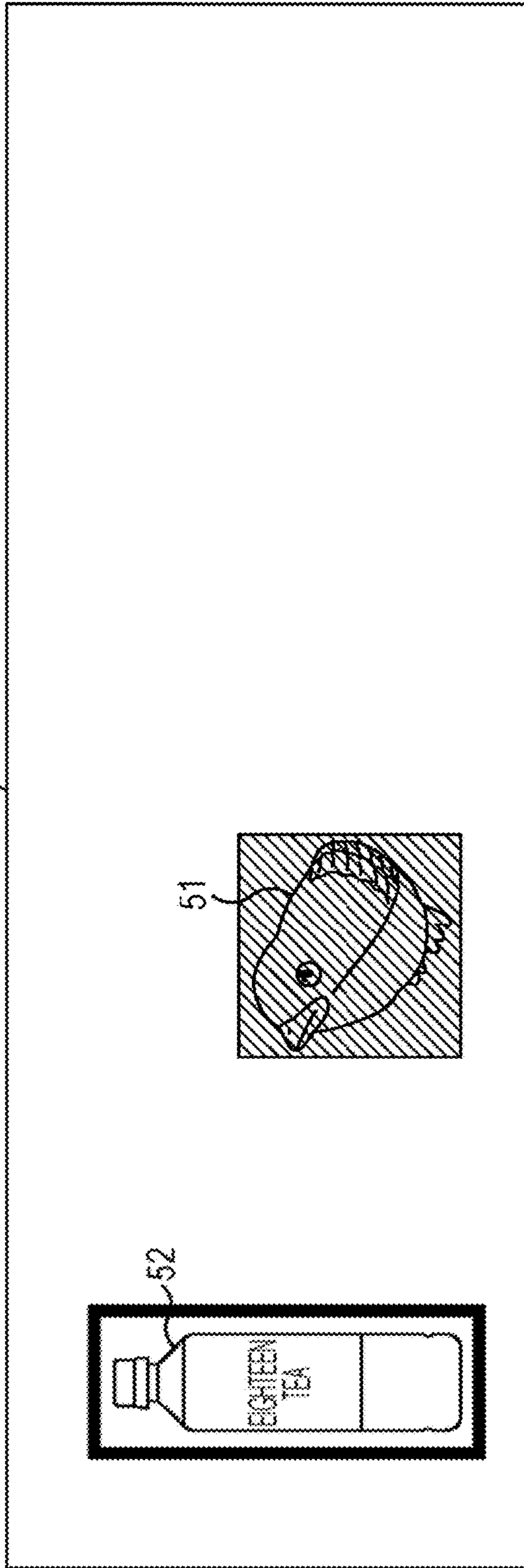

FIG. 12

21a

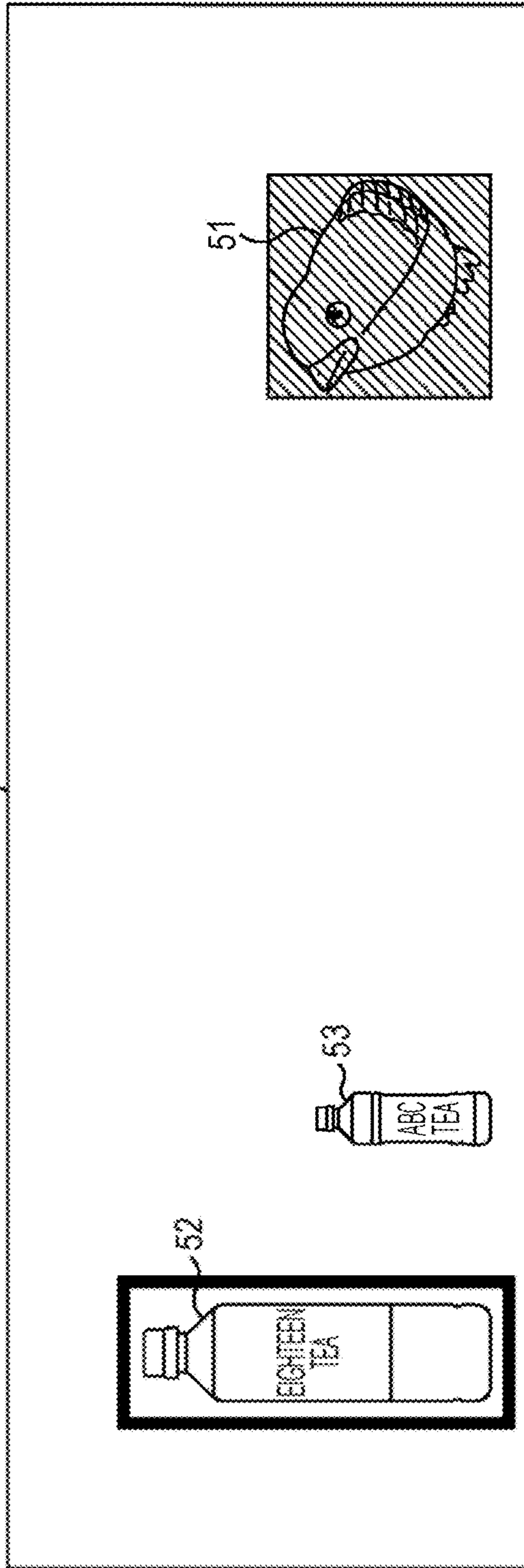

FIG. 13

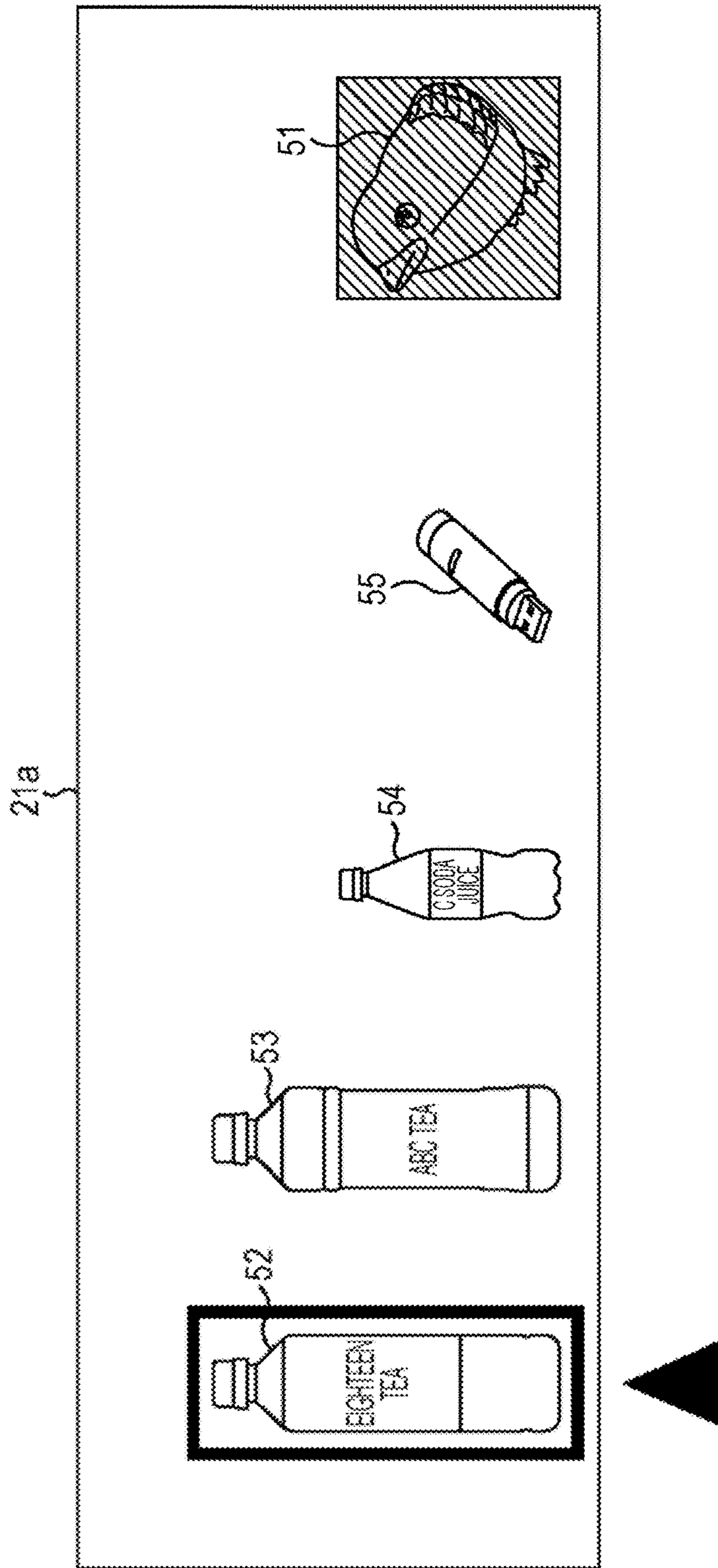

FIG. 14

21a

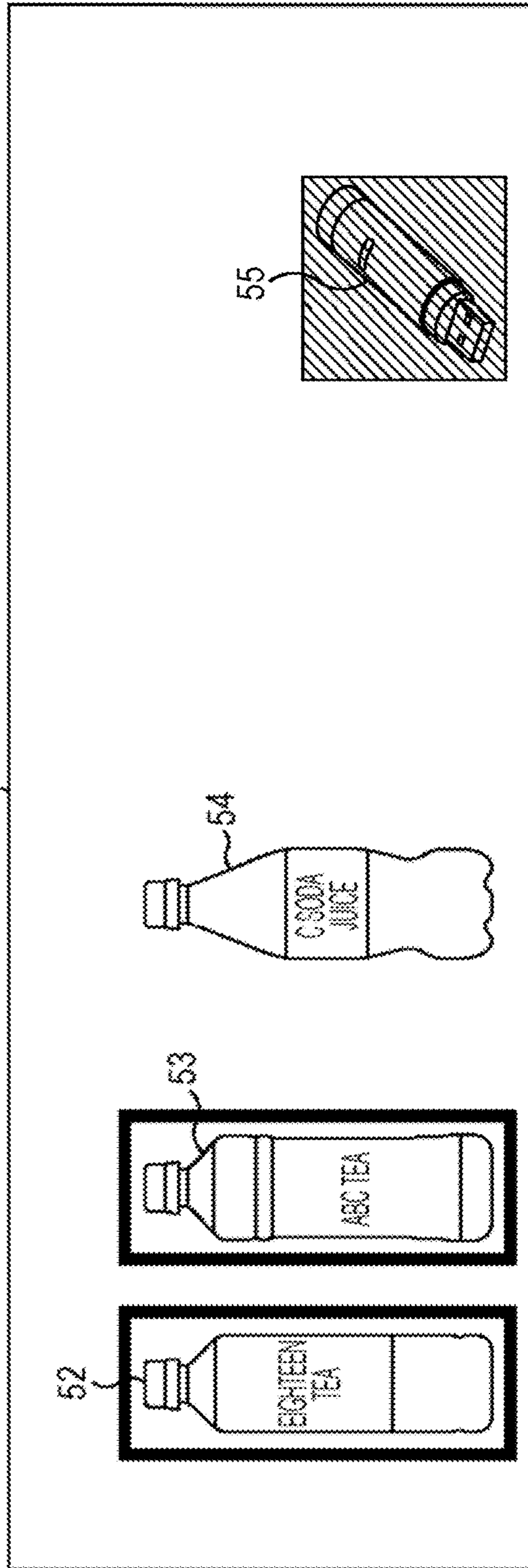

FIG. 15

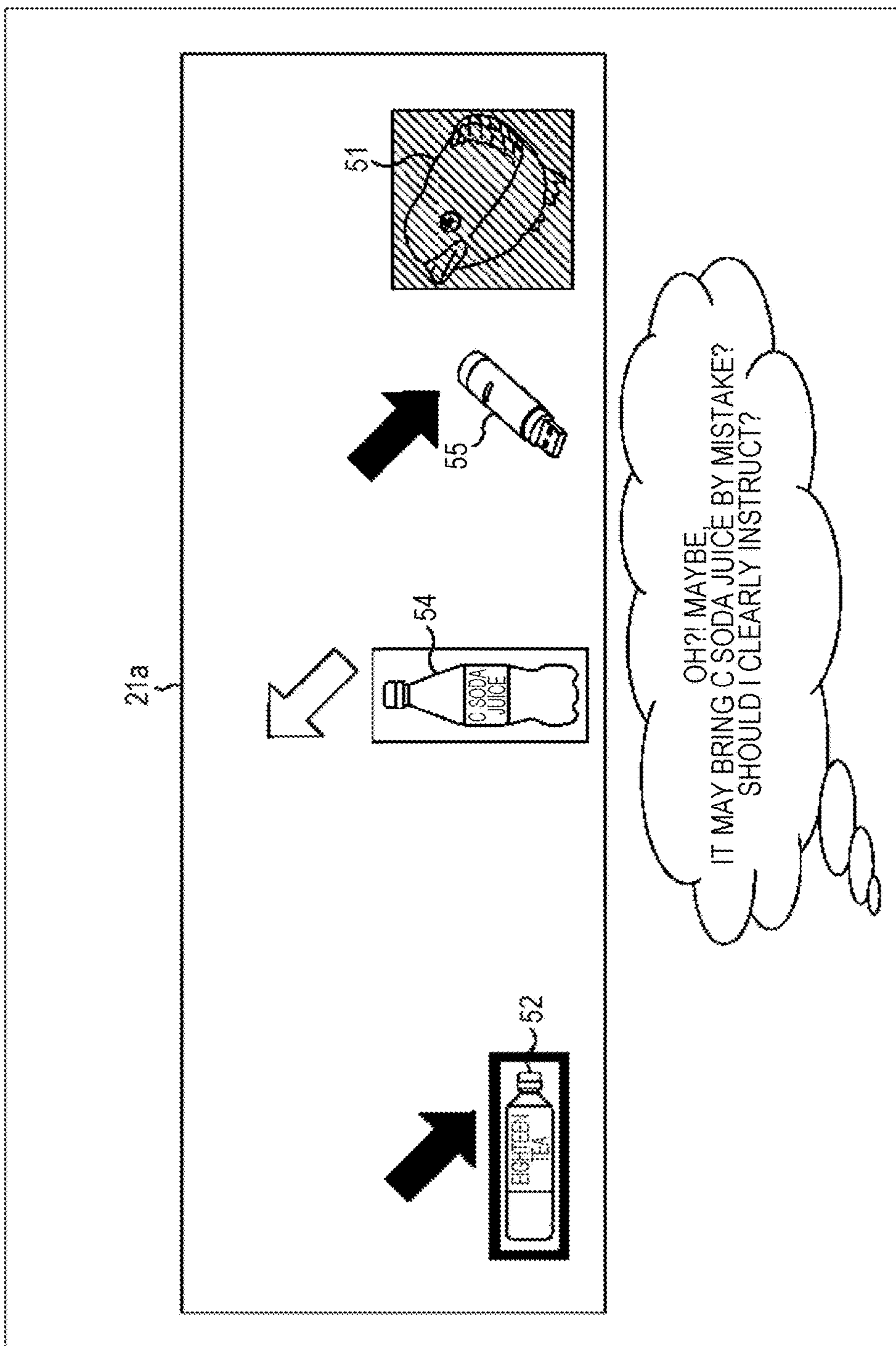

FIG. 16

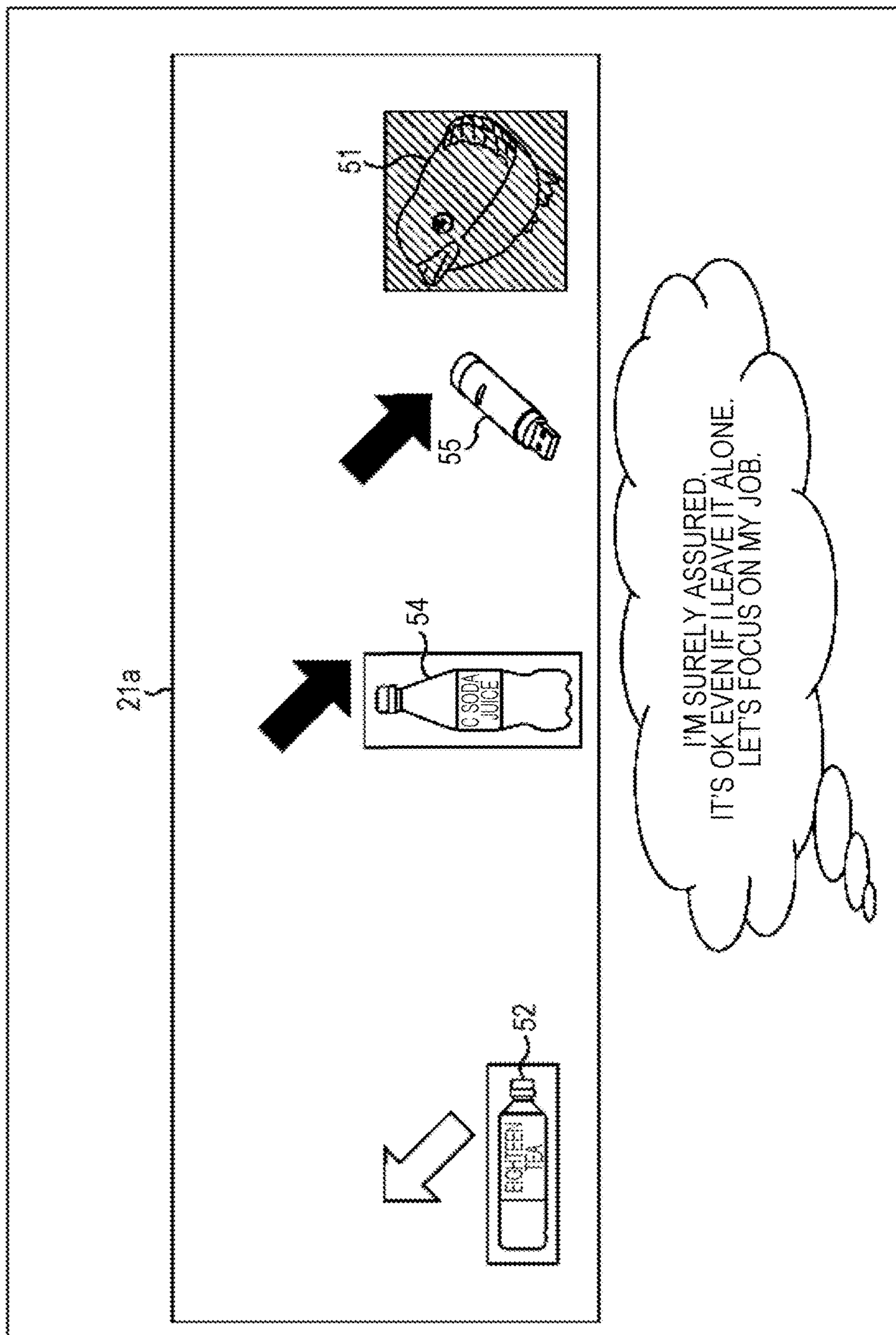

FIG. 17

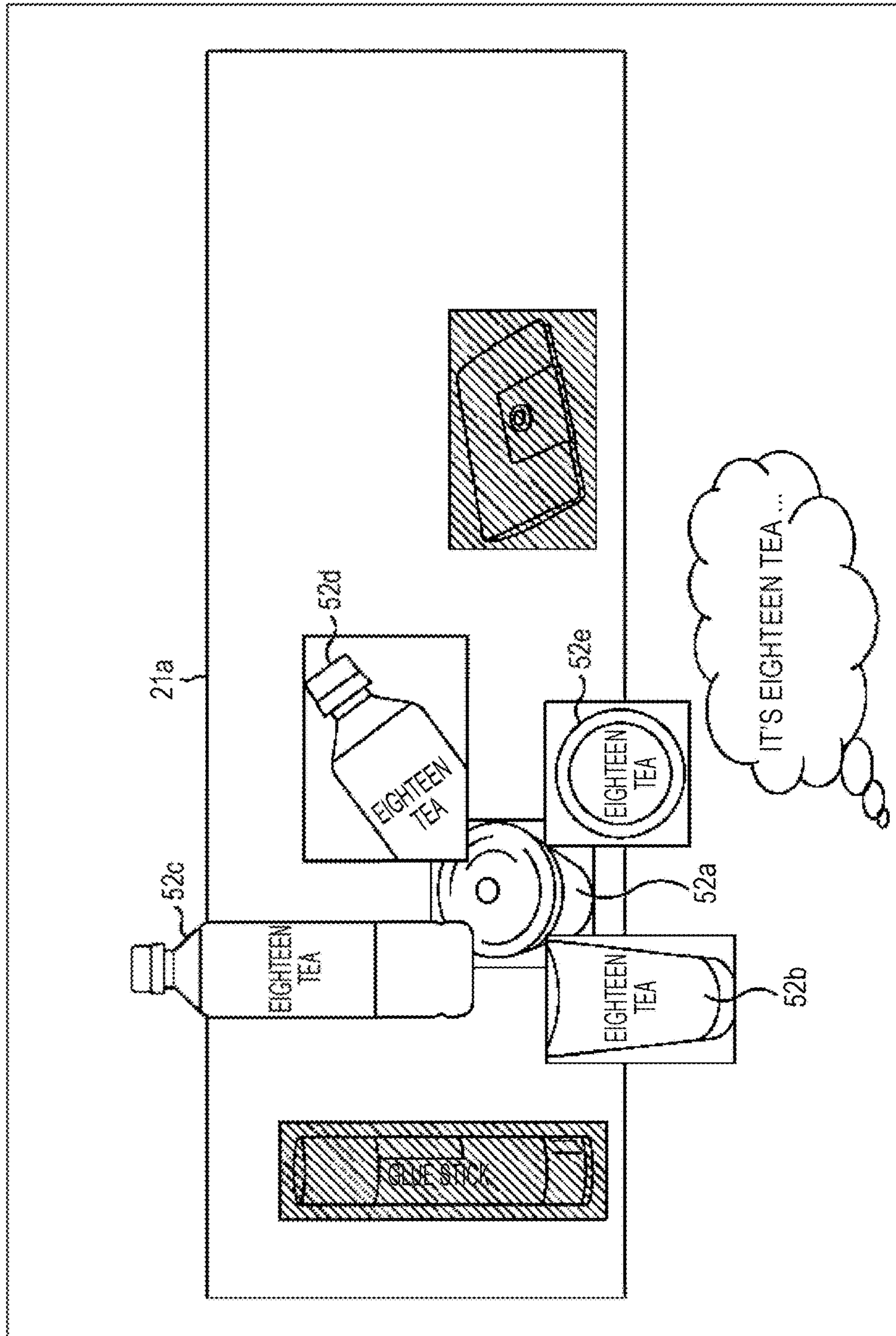

FIG. 18

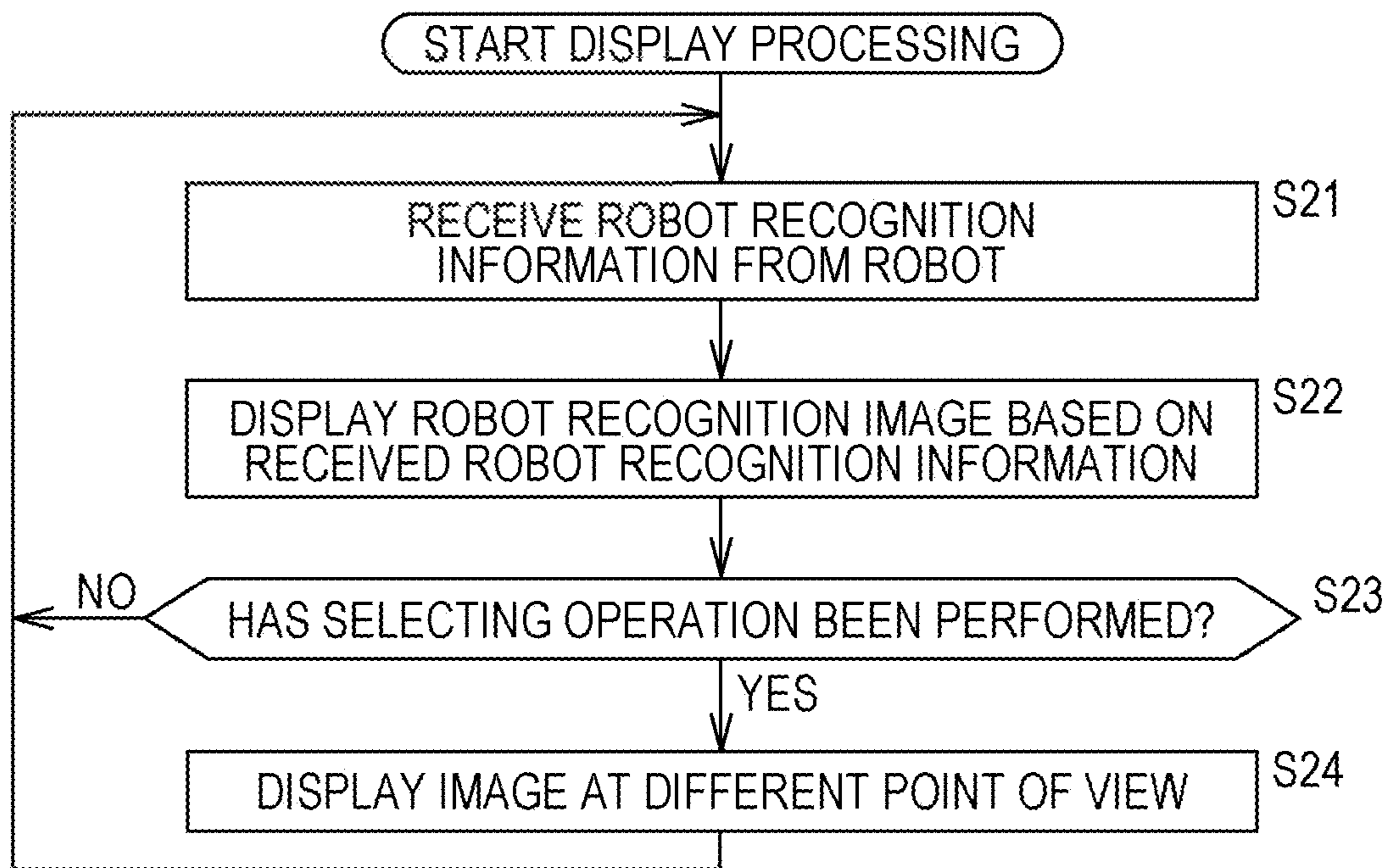

FIG. 19

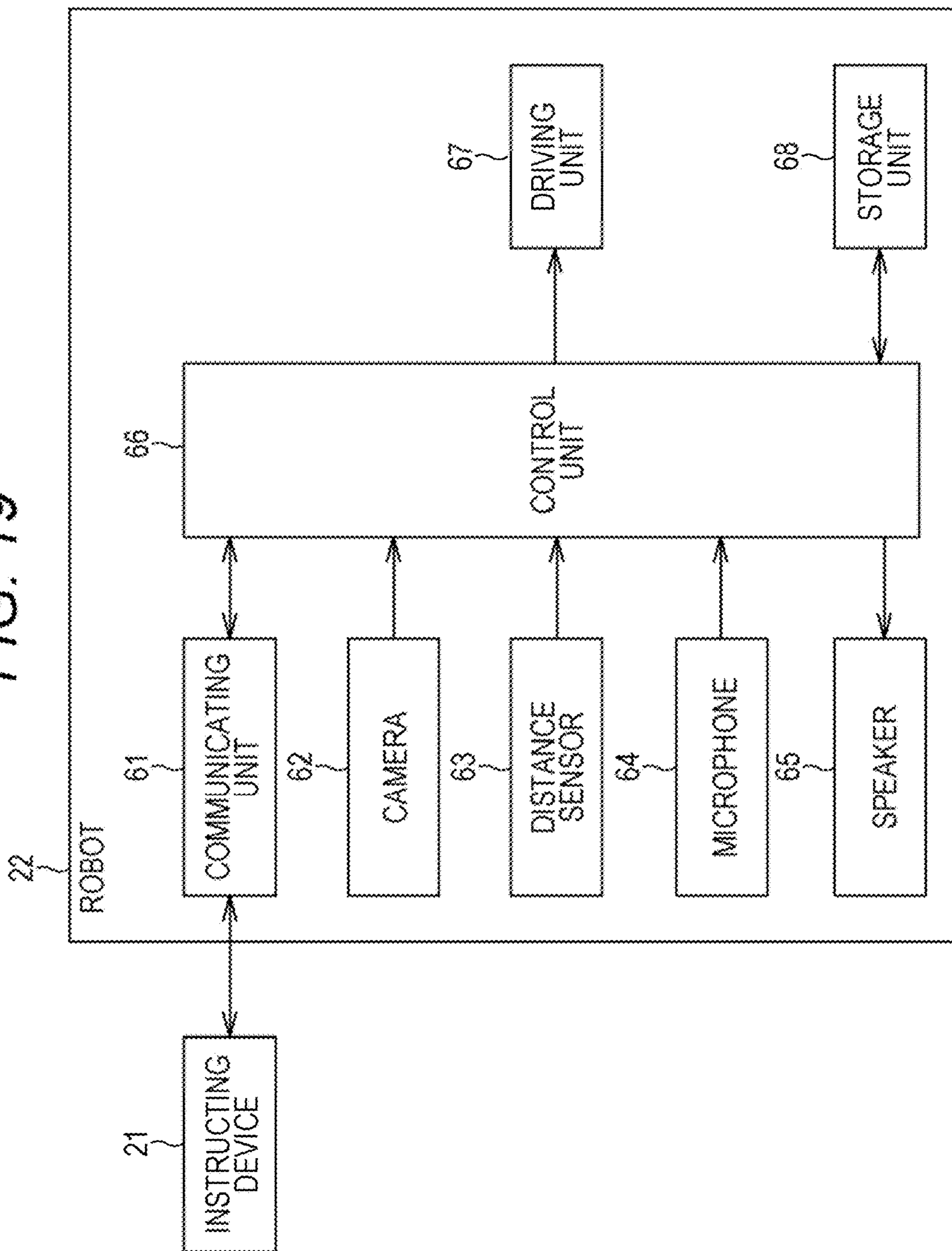

FIG. 20

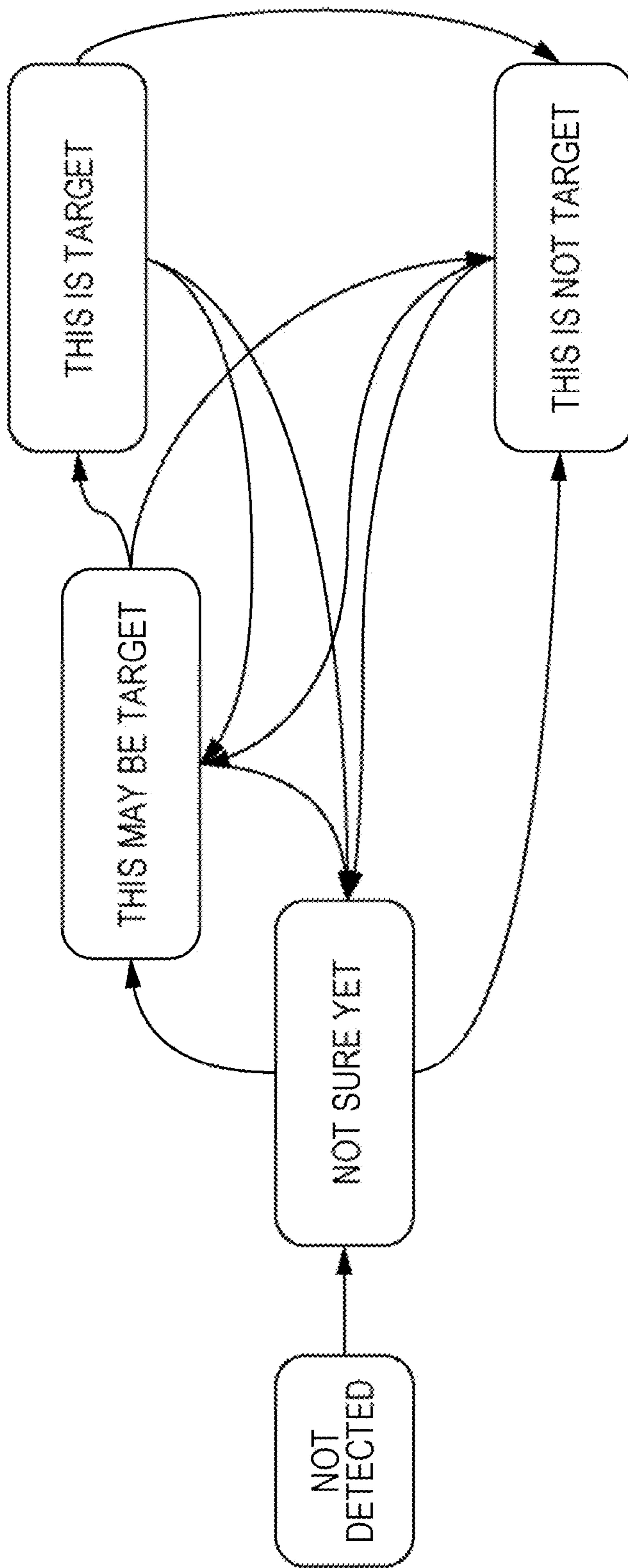

FIG. 21

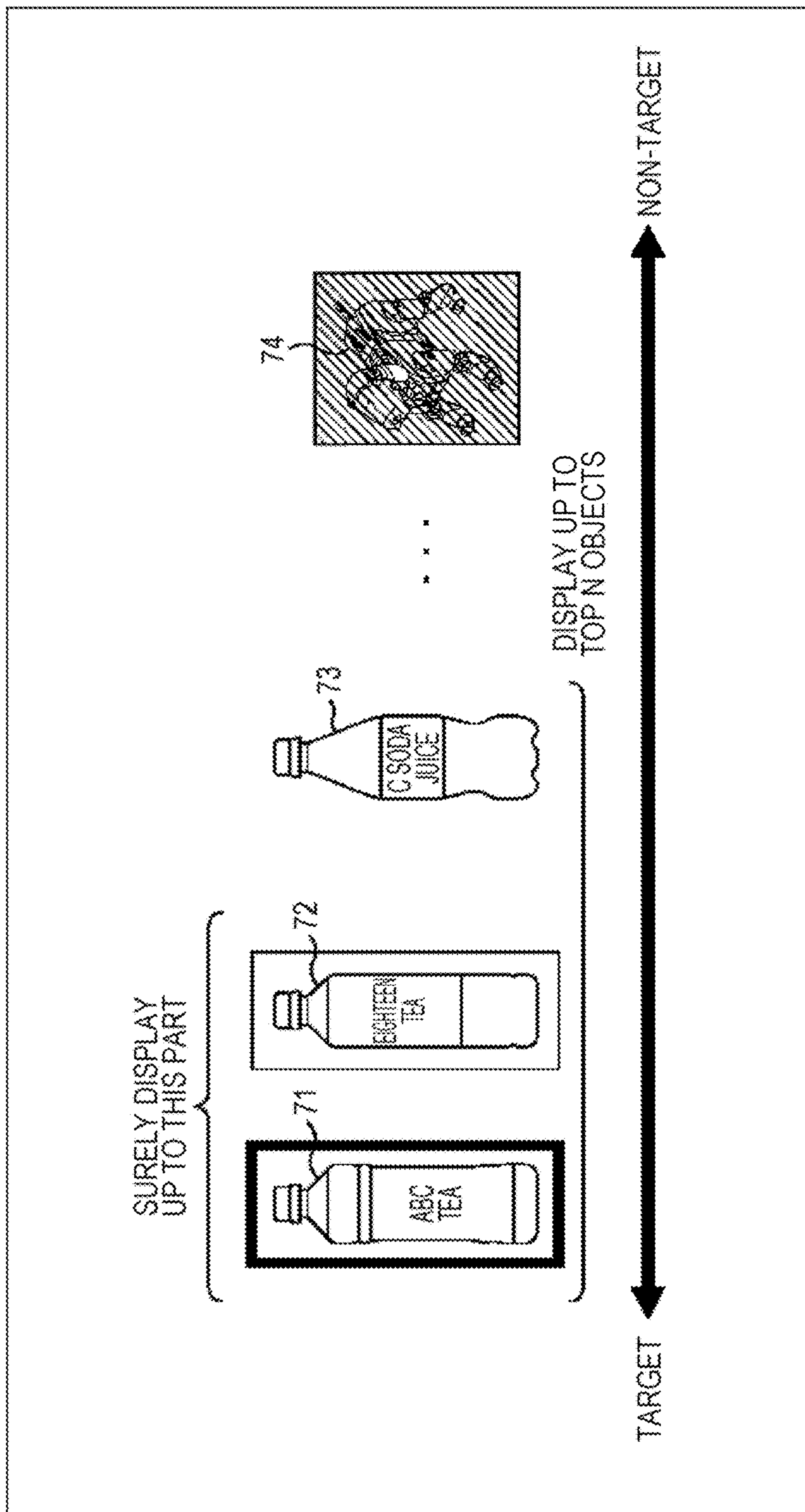

FIG. 22

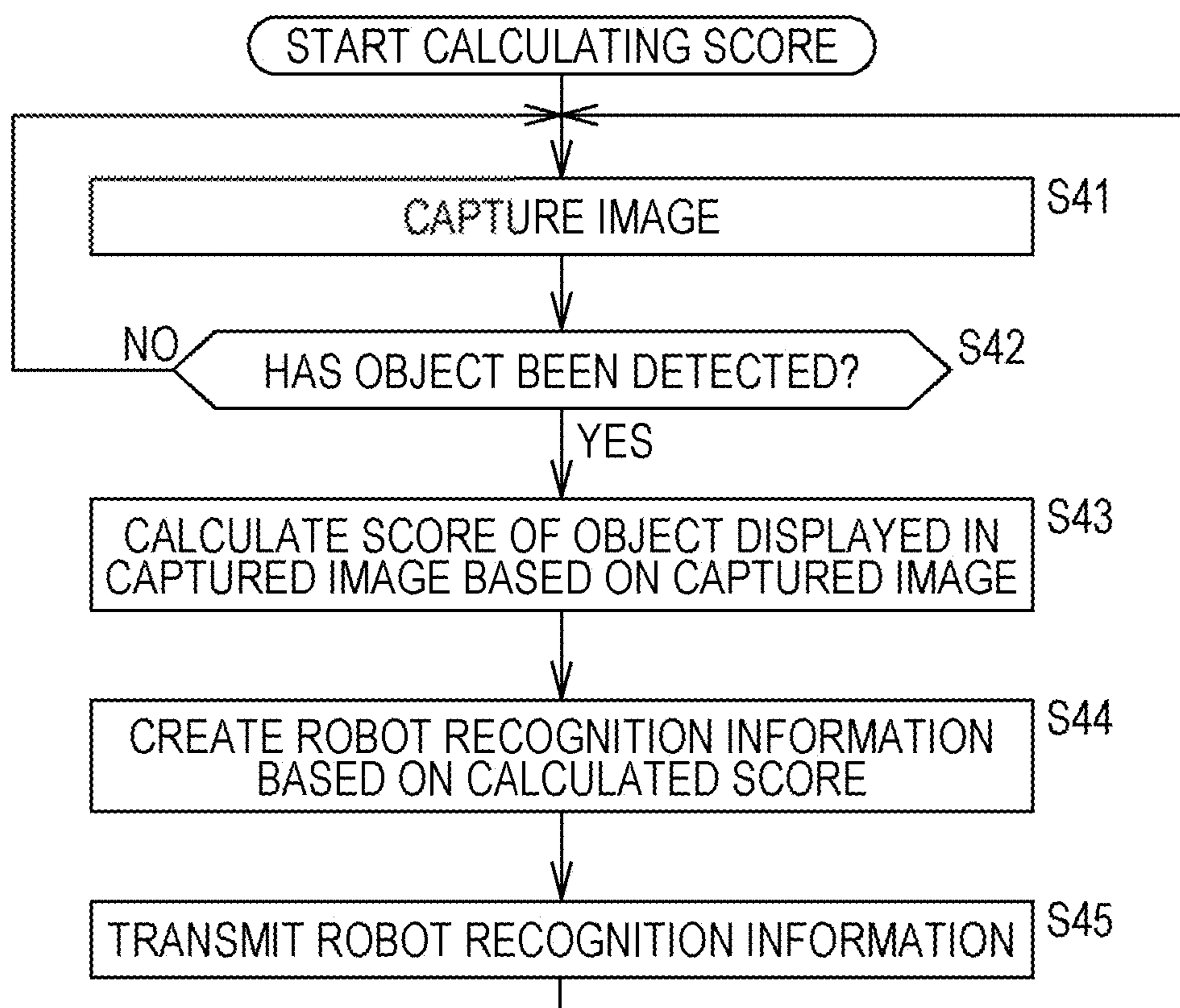

FIG. 23

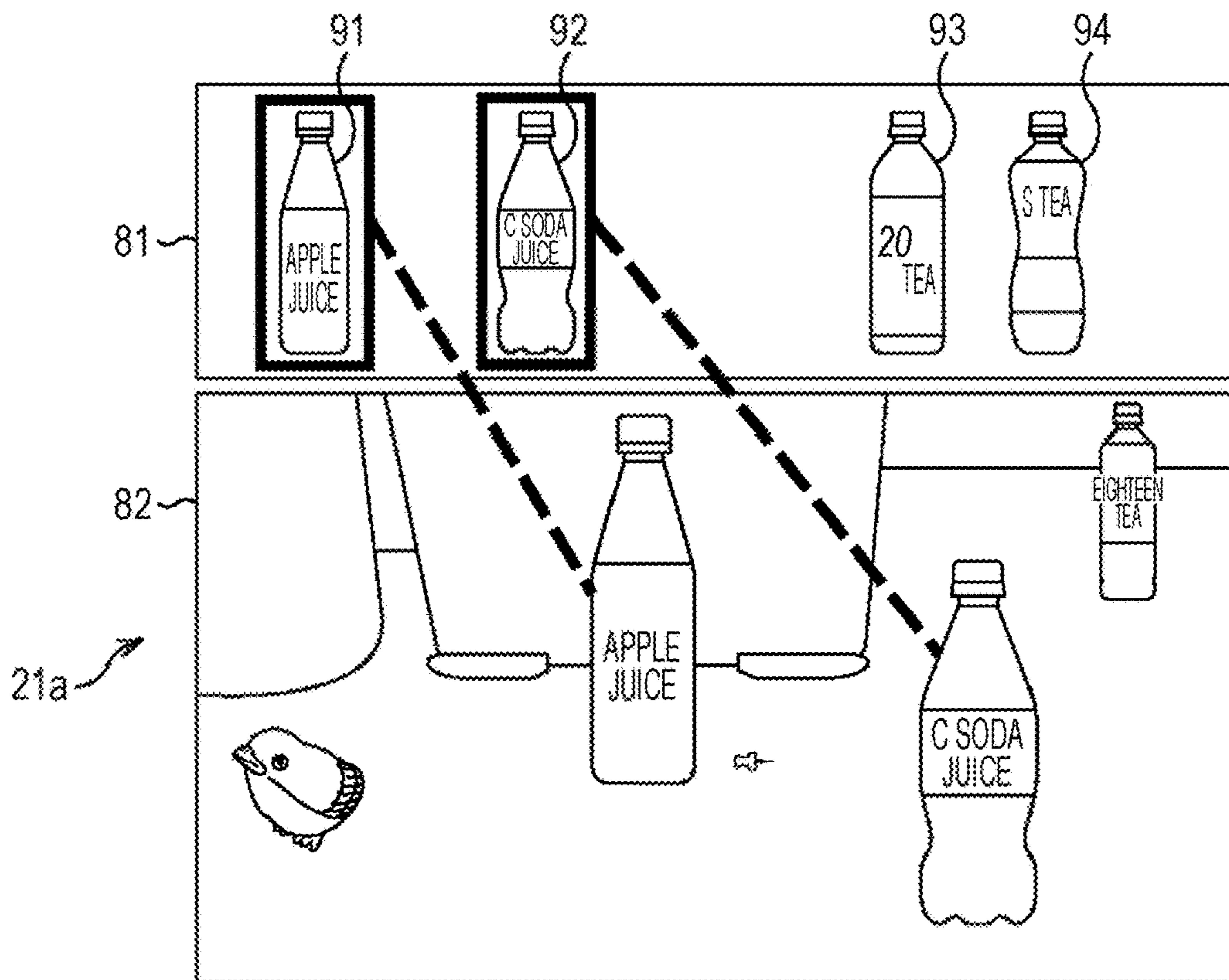

FIG. 24

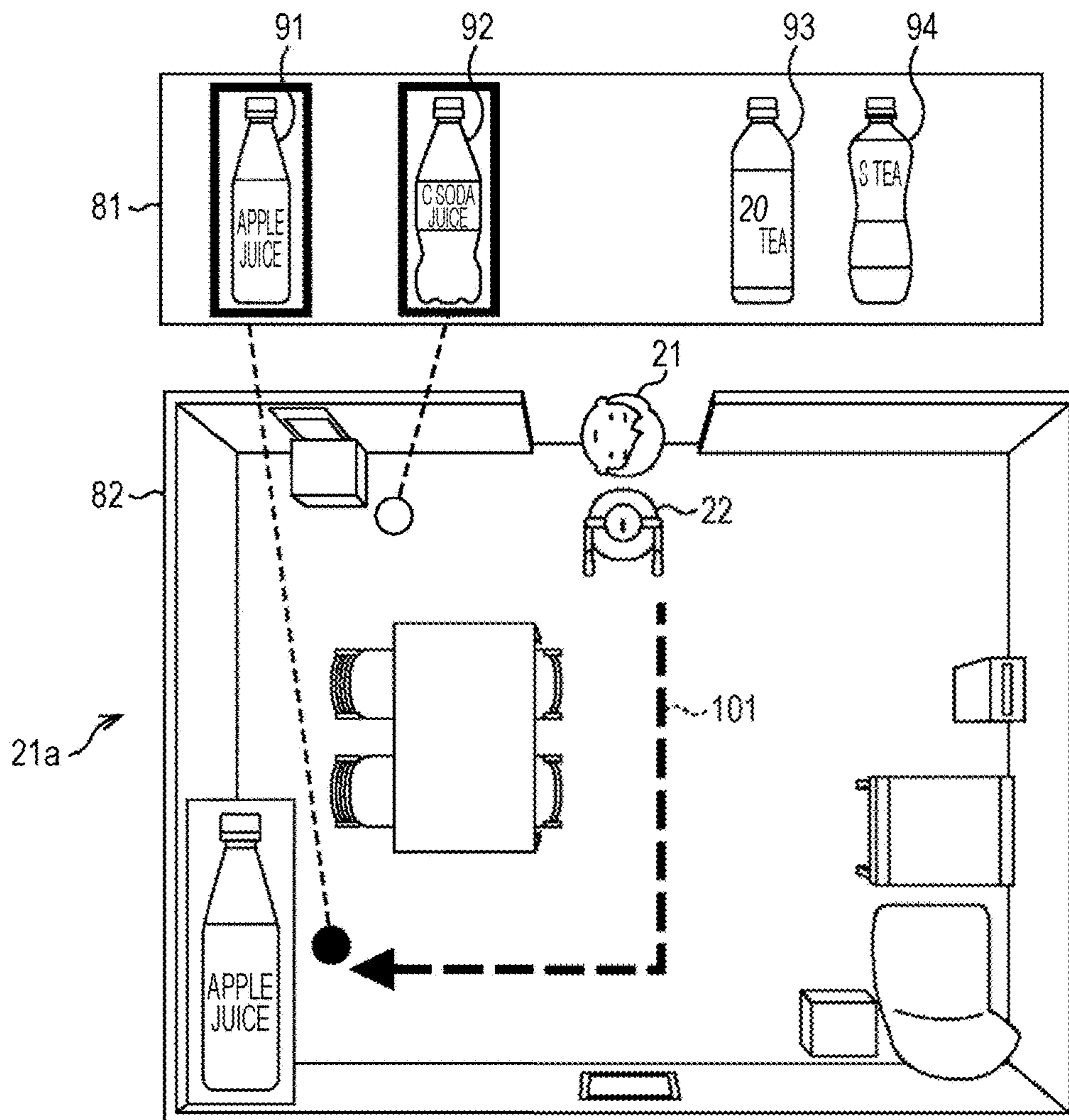

FIG. 25

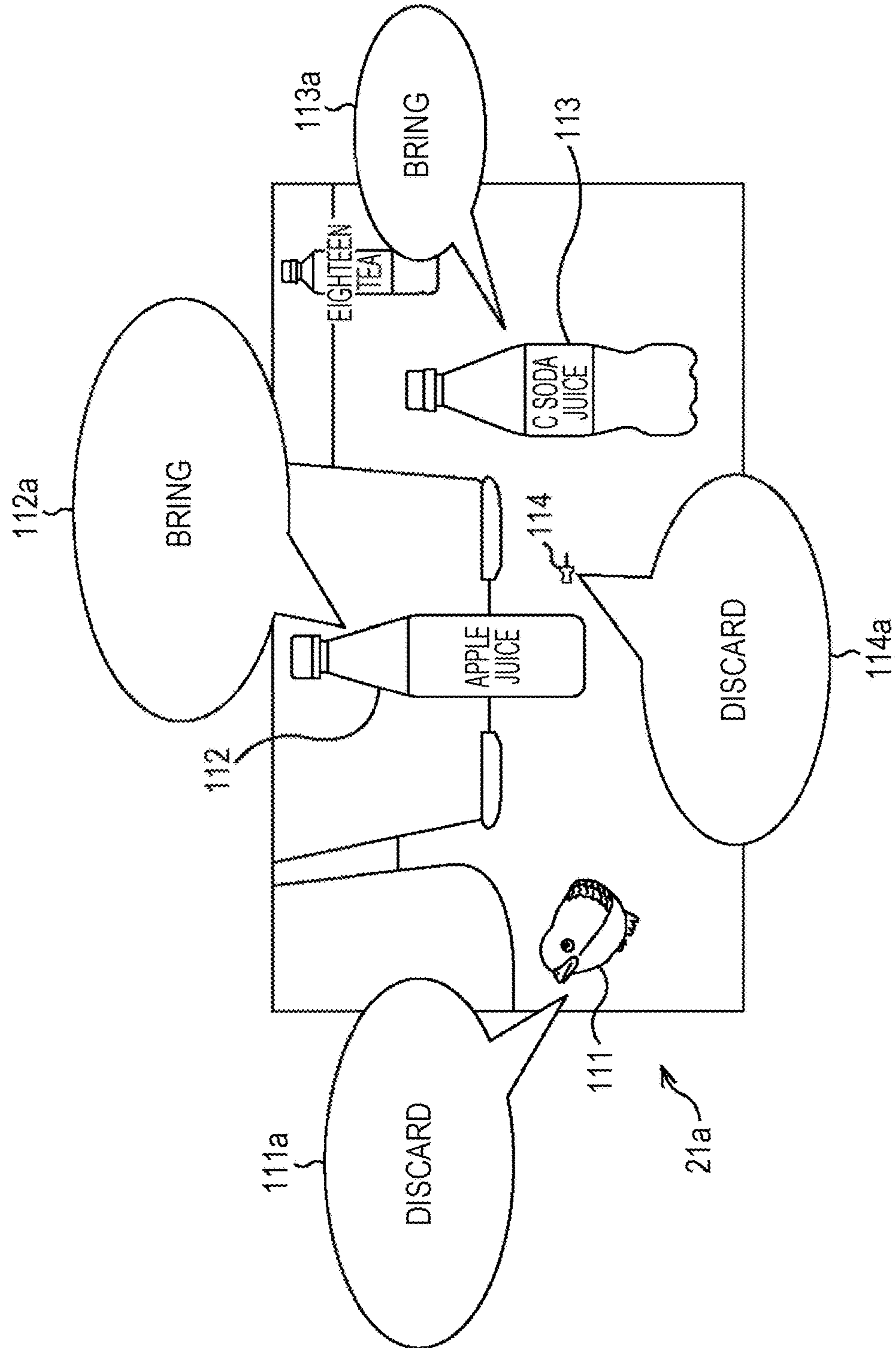

FIG. 26

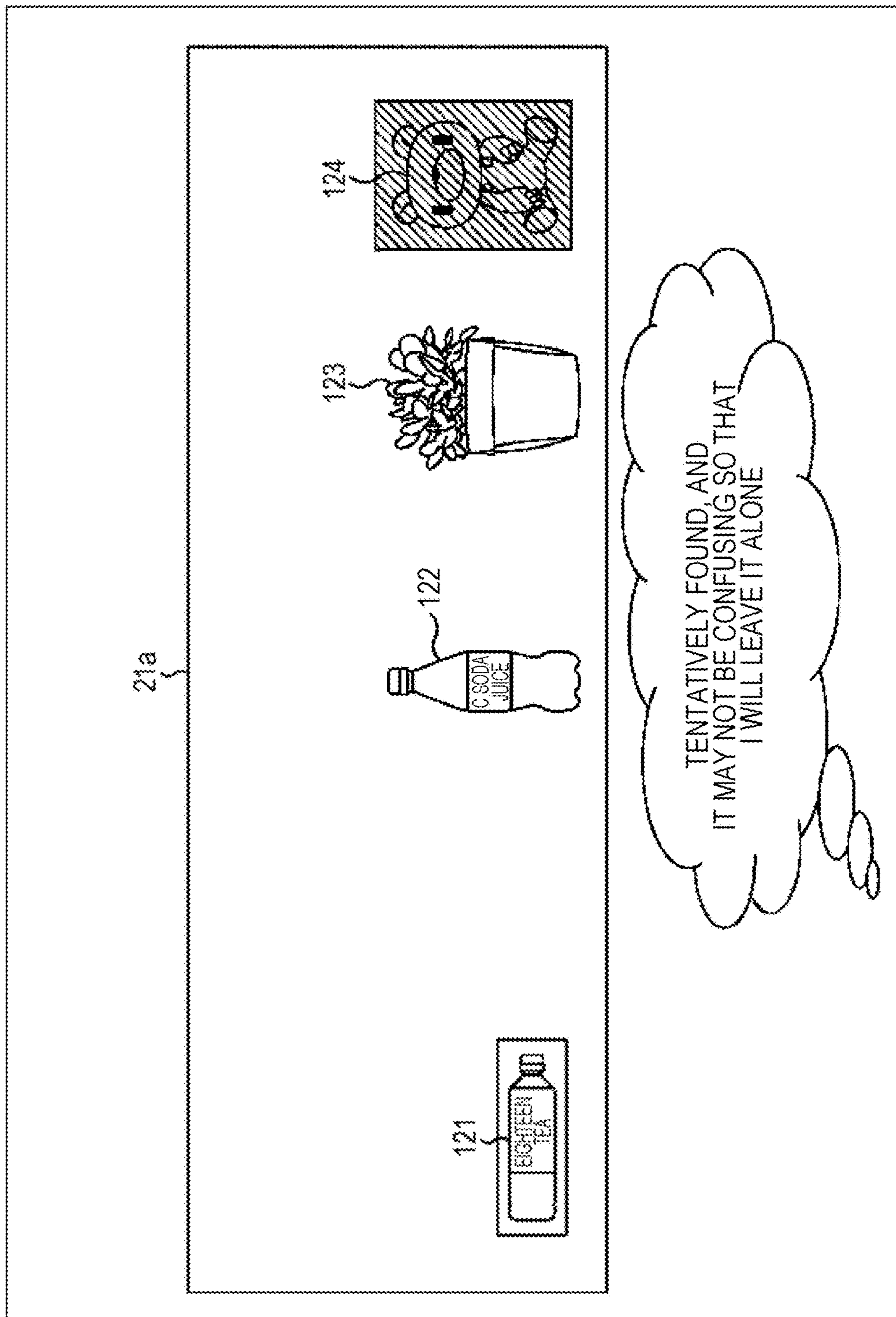

FIG. 27

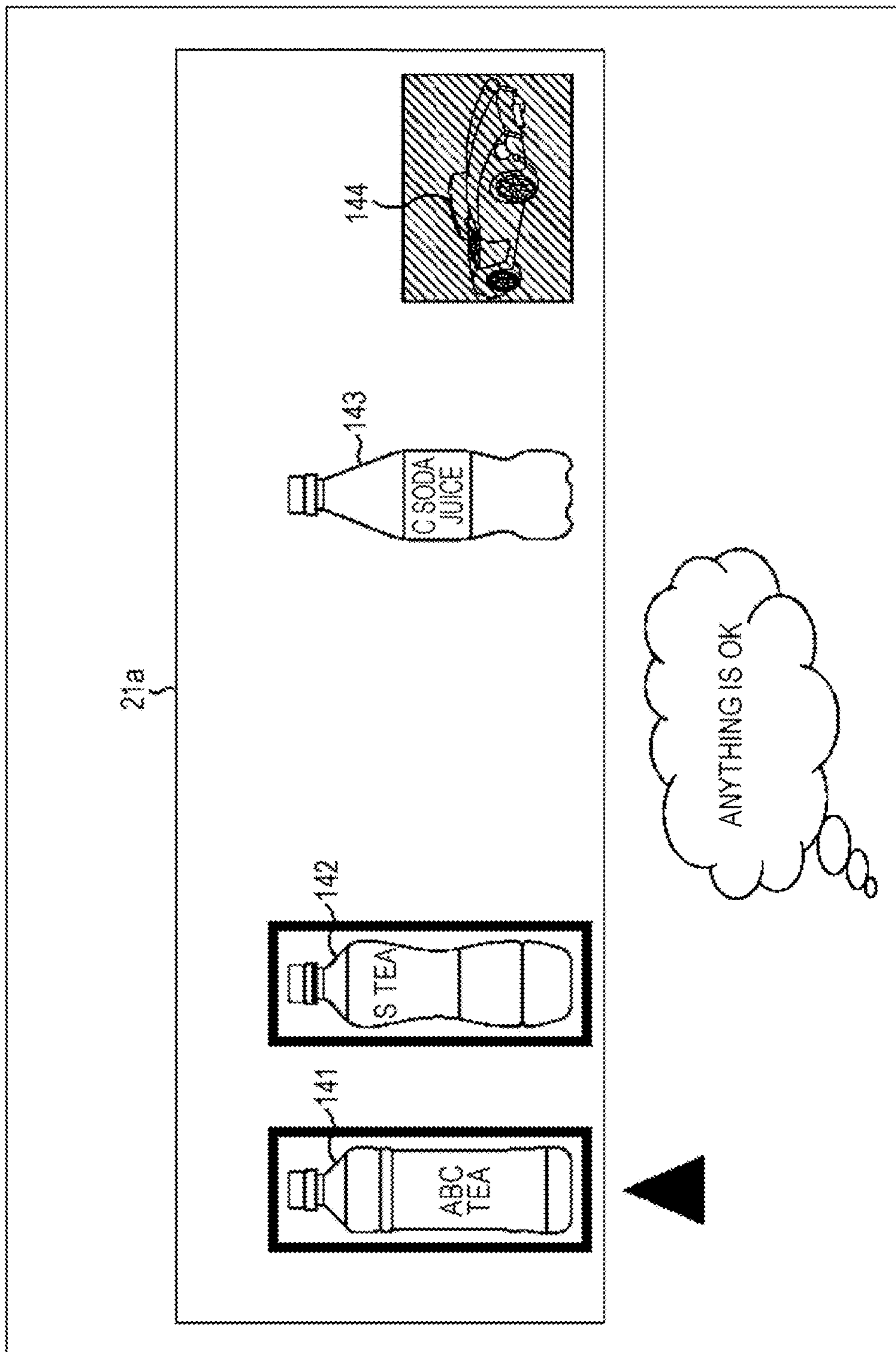

FIG. 28

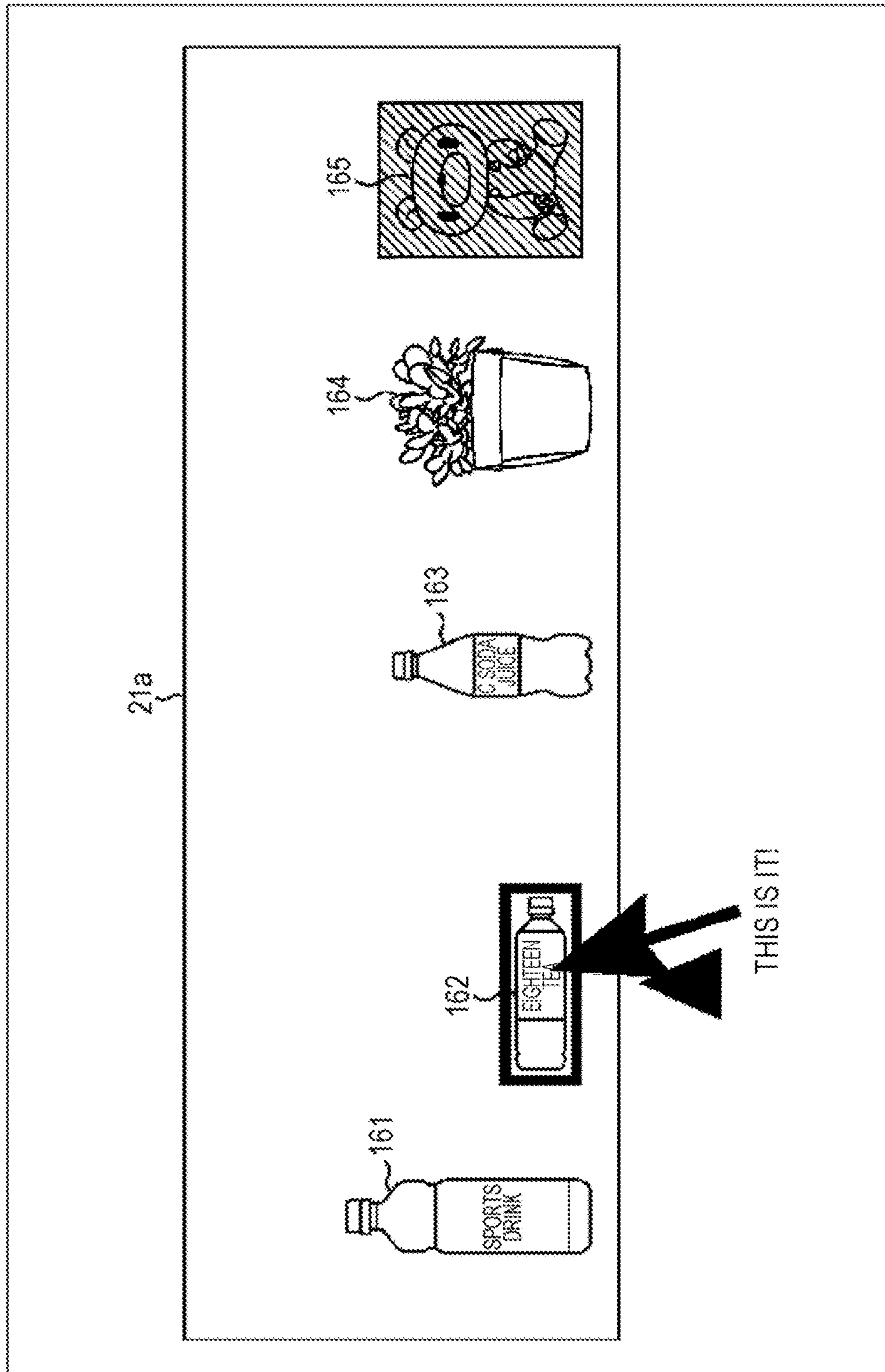

FIG. 29

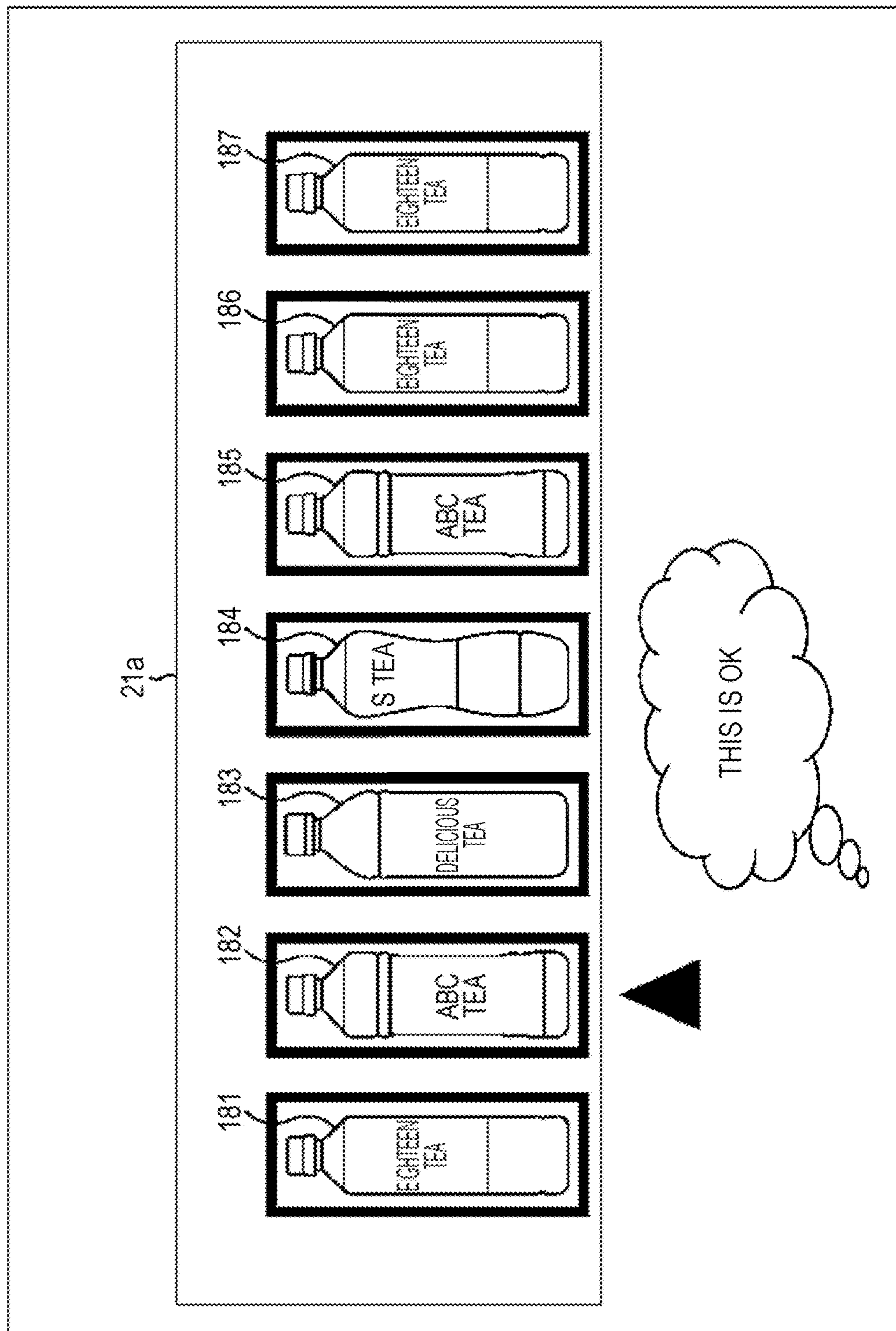

FIG. 30

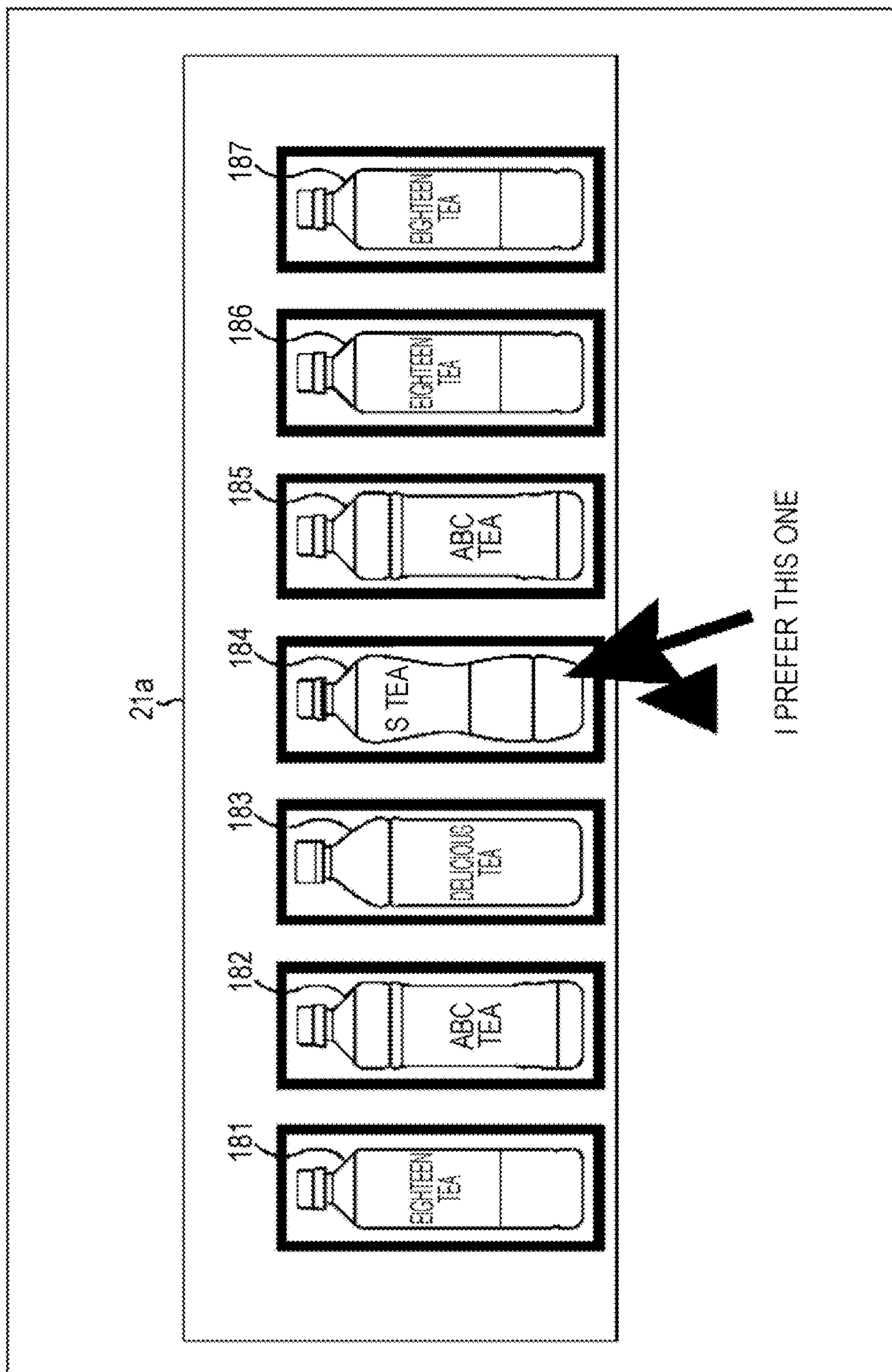

FIG. 31

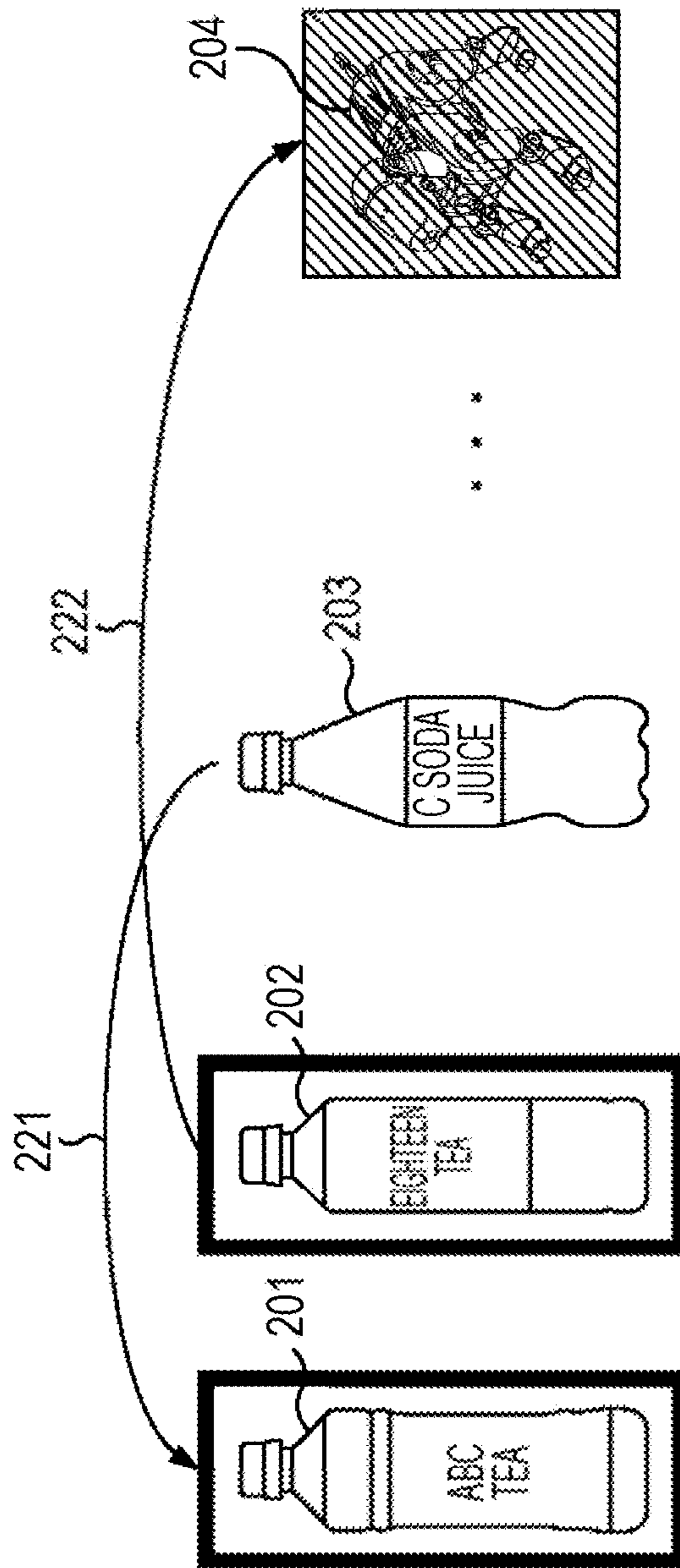

FIG. 32

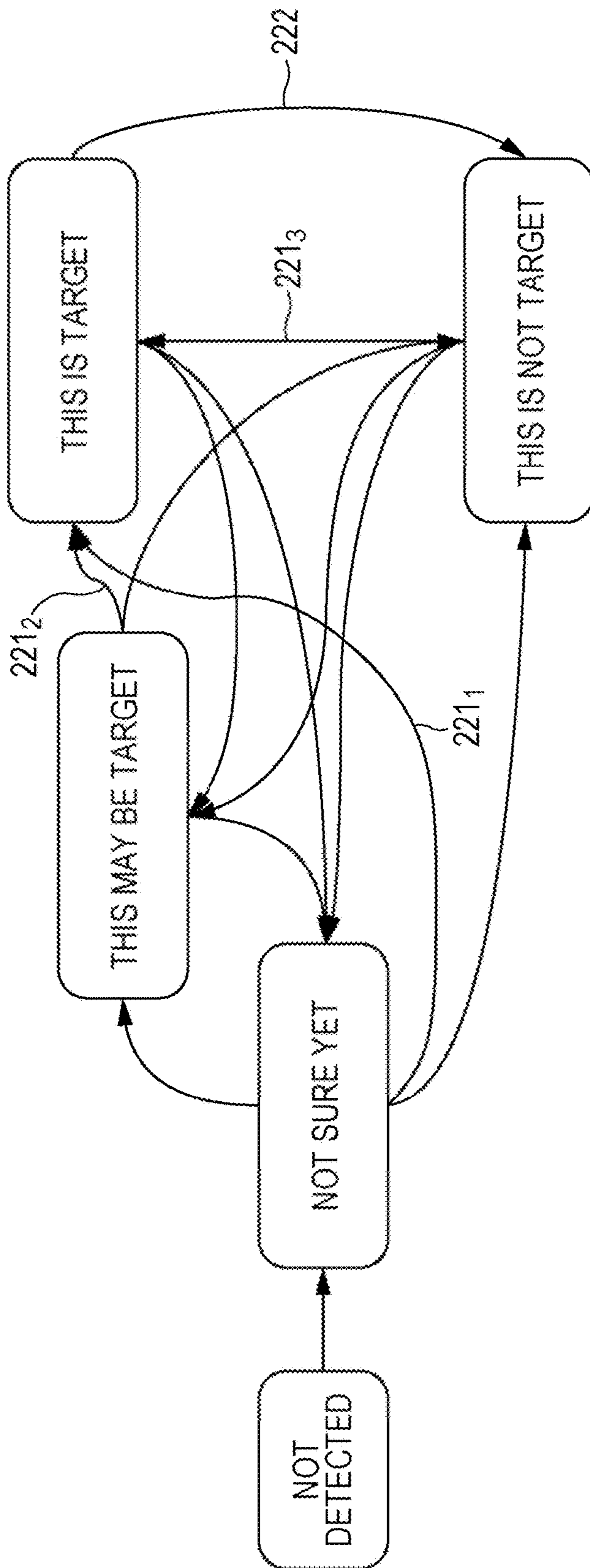

FIG. 33

21a

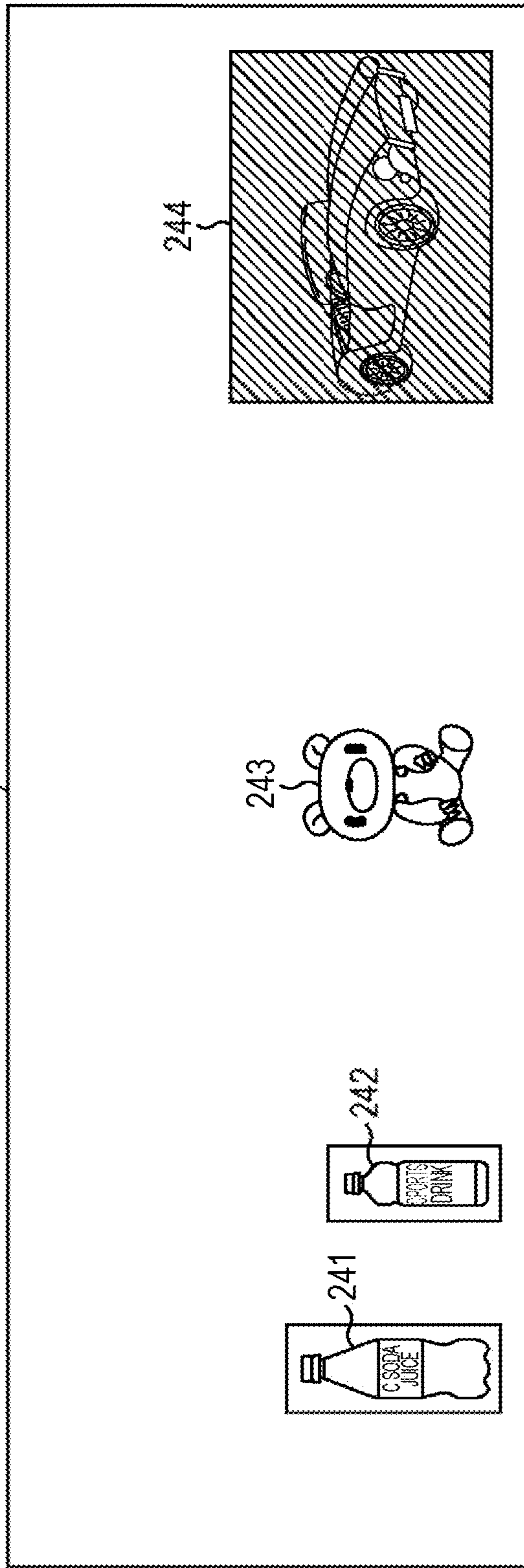

FIG. 34

21a

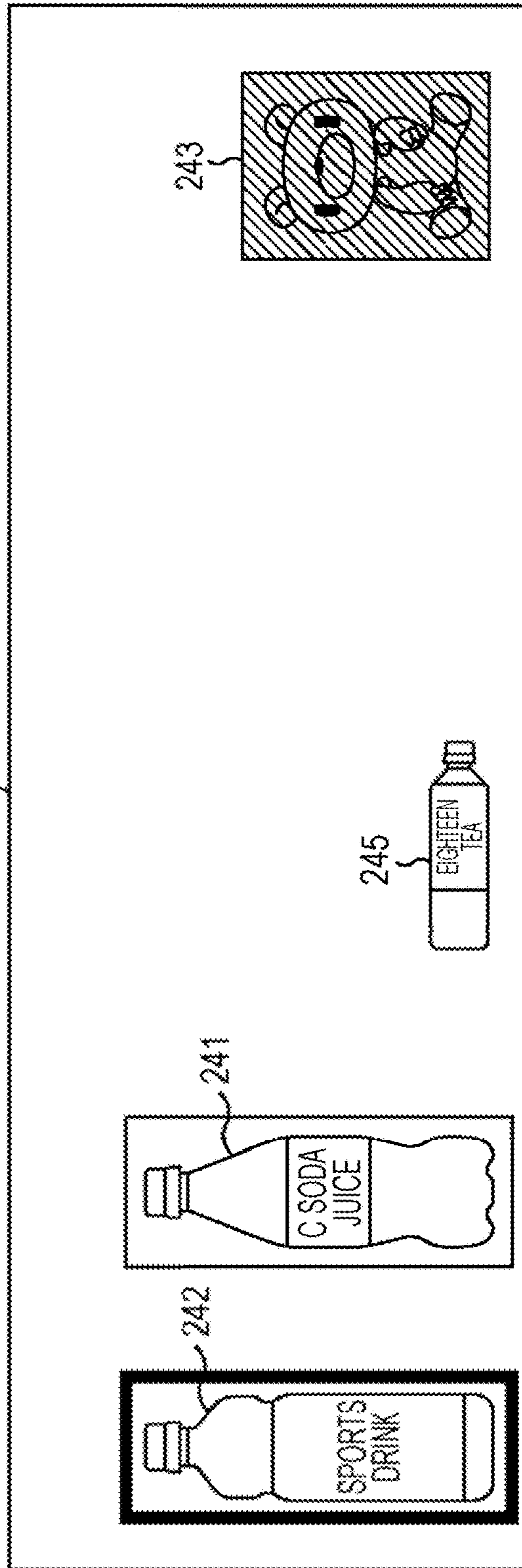

FIG. 35

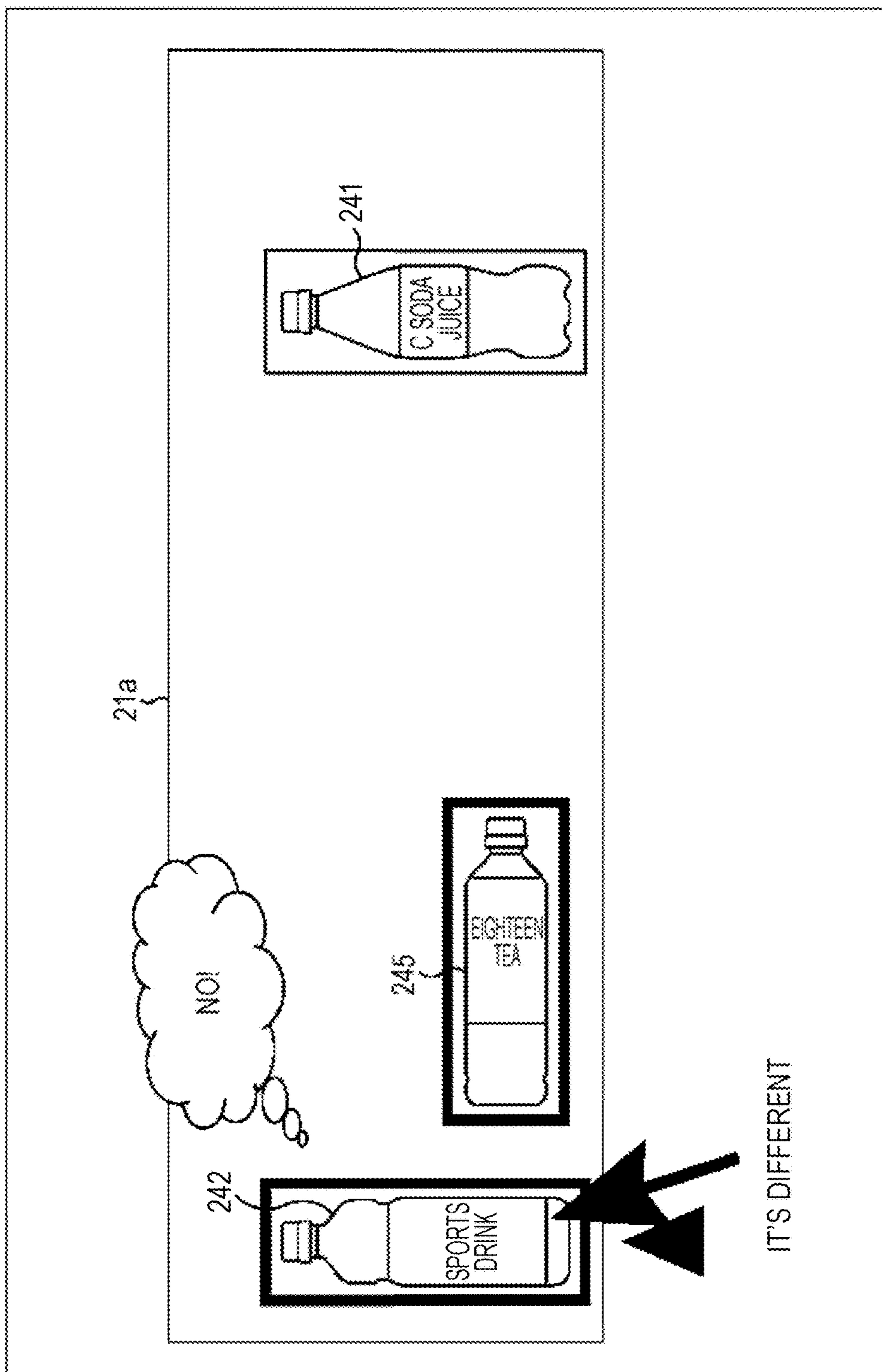

FIG. 36

21a

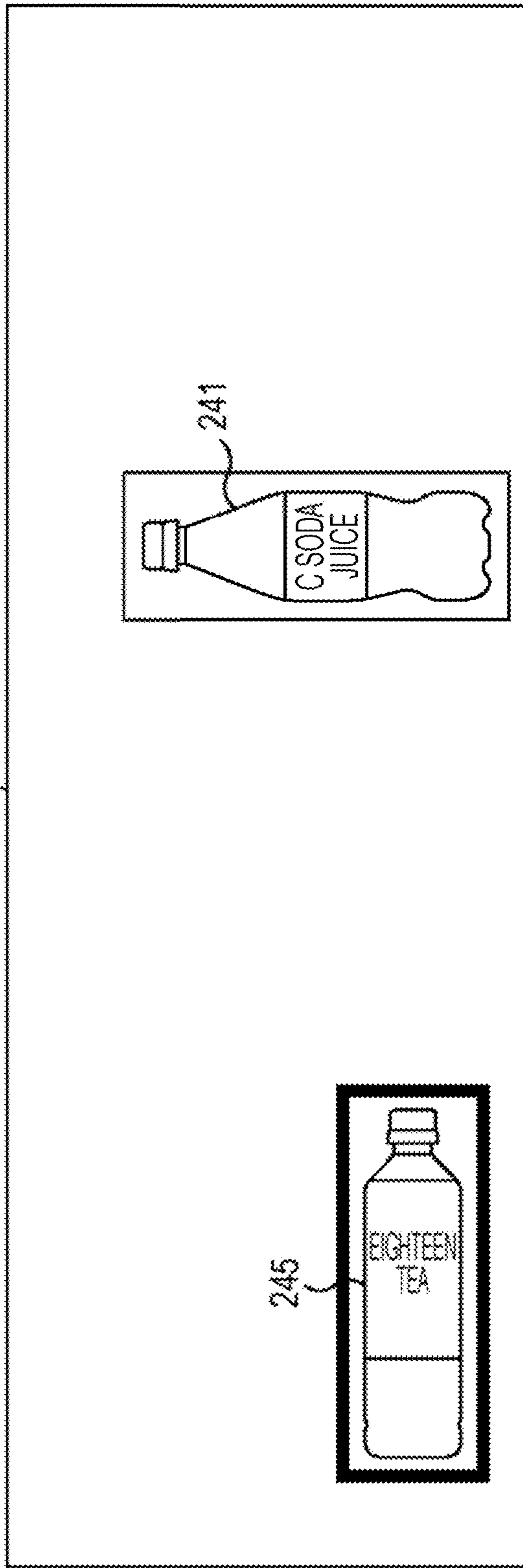

FIG. 37

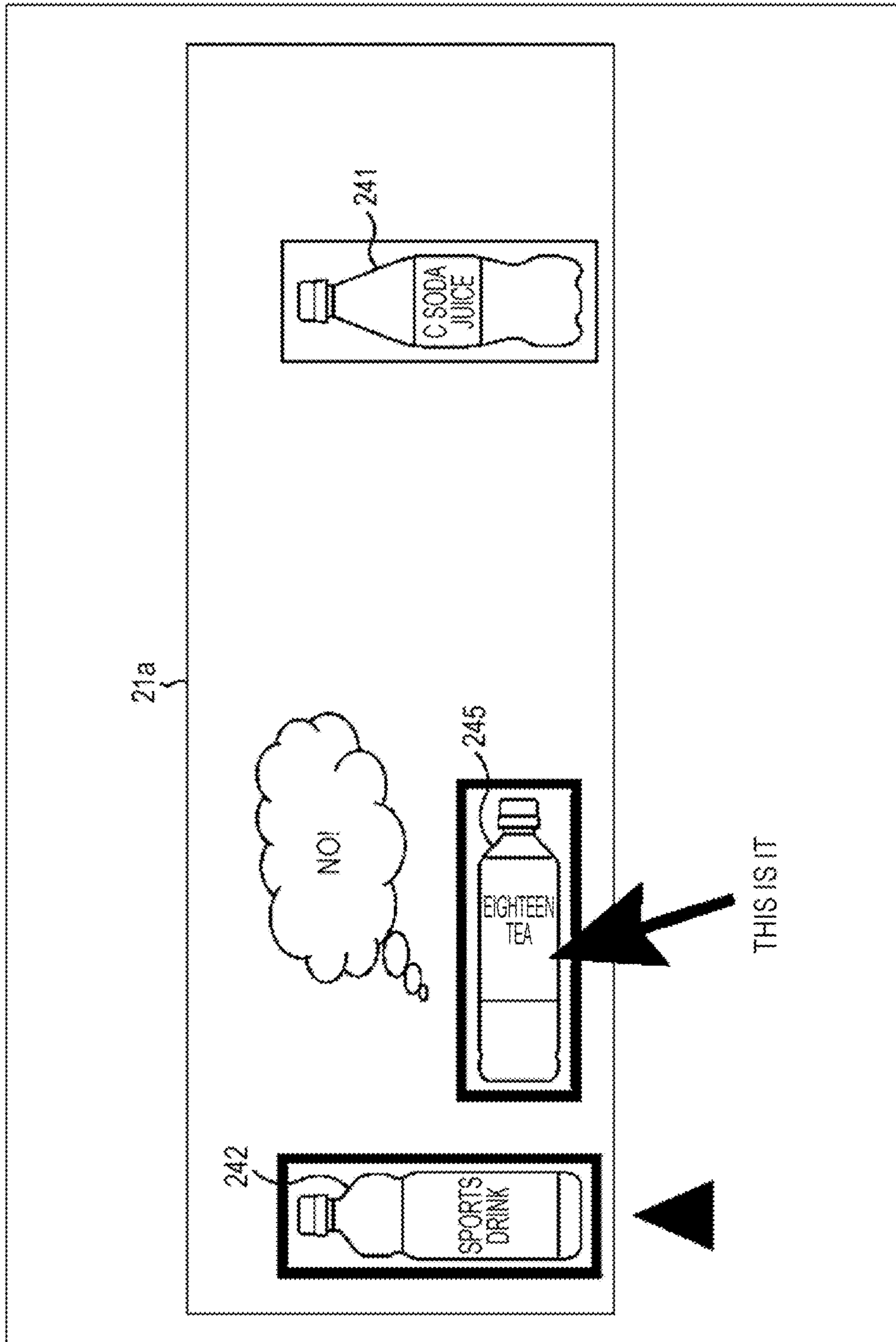

FIG. 38

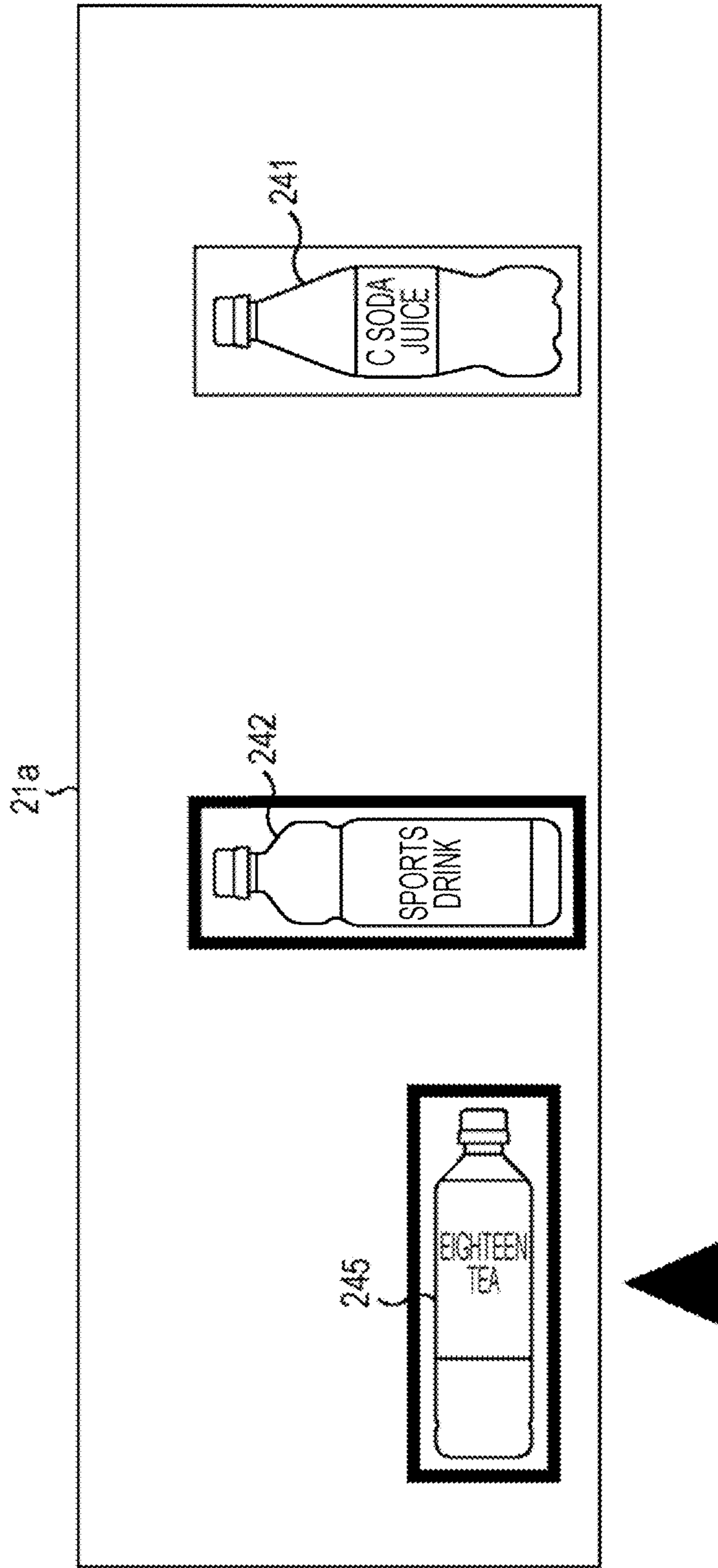

FIG. 39

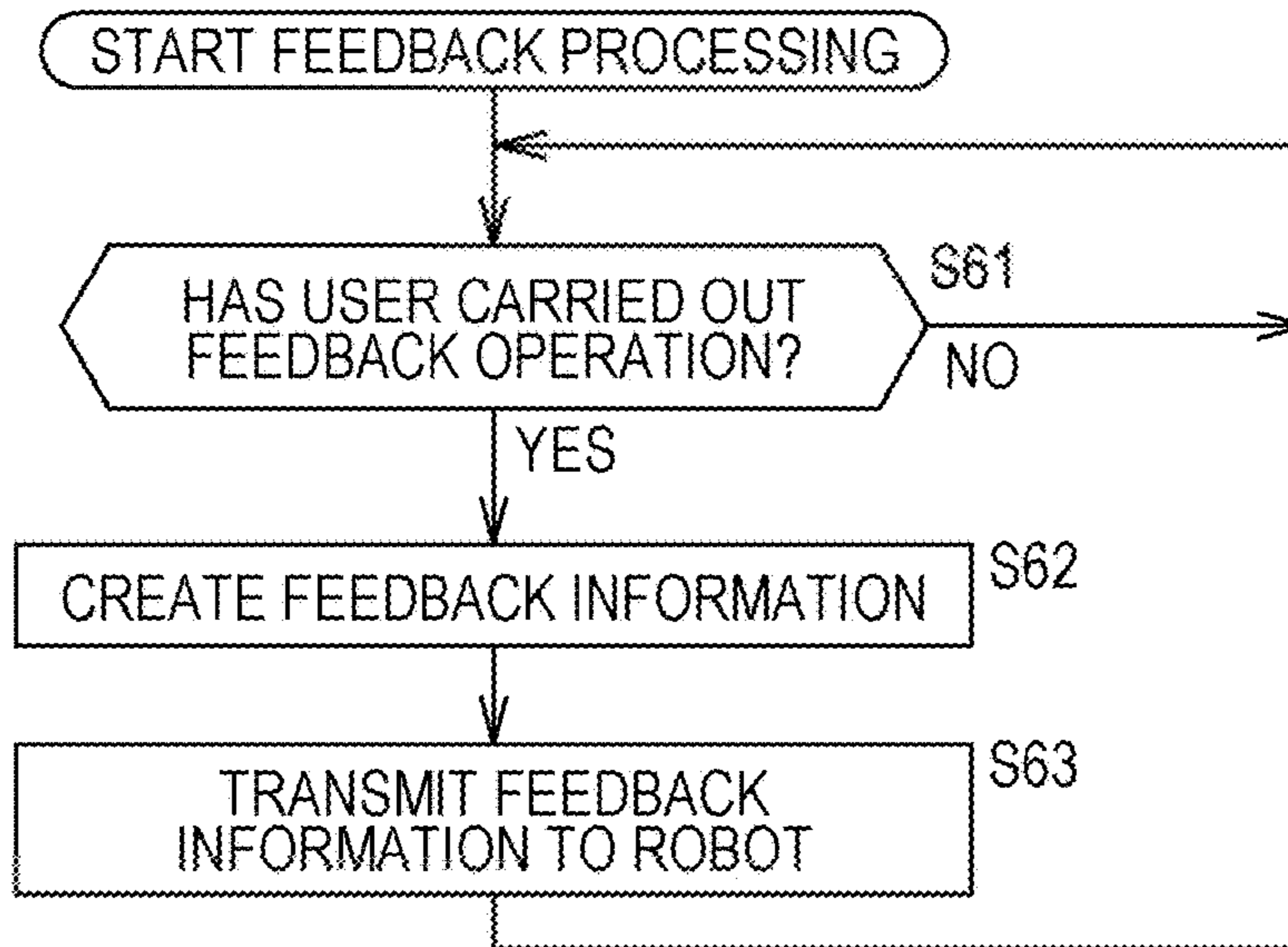

FIG. 40

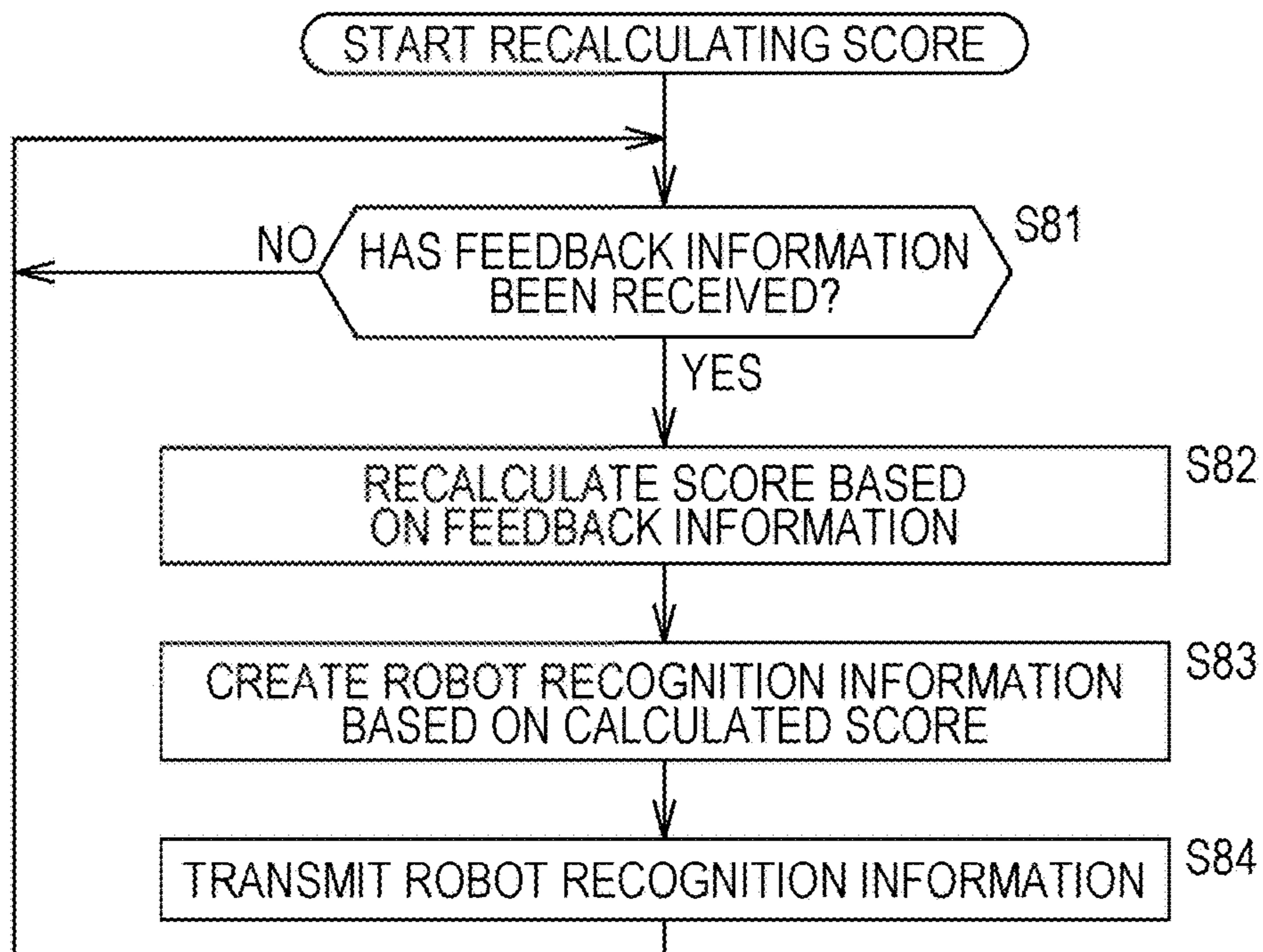

FIG. 41

21a



FIG. 42

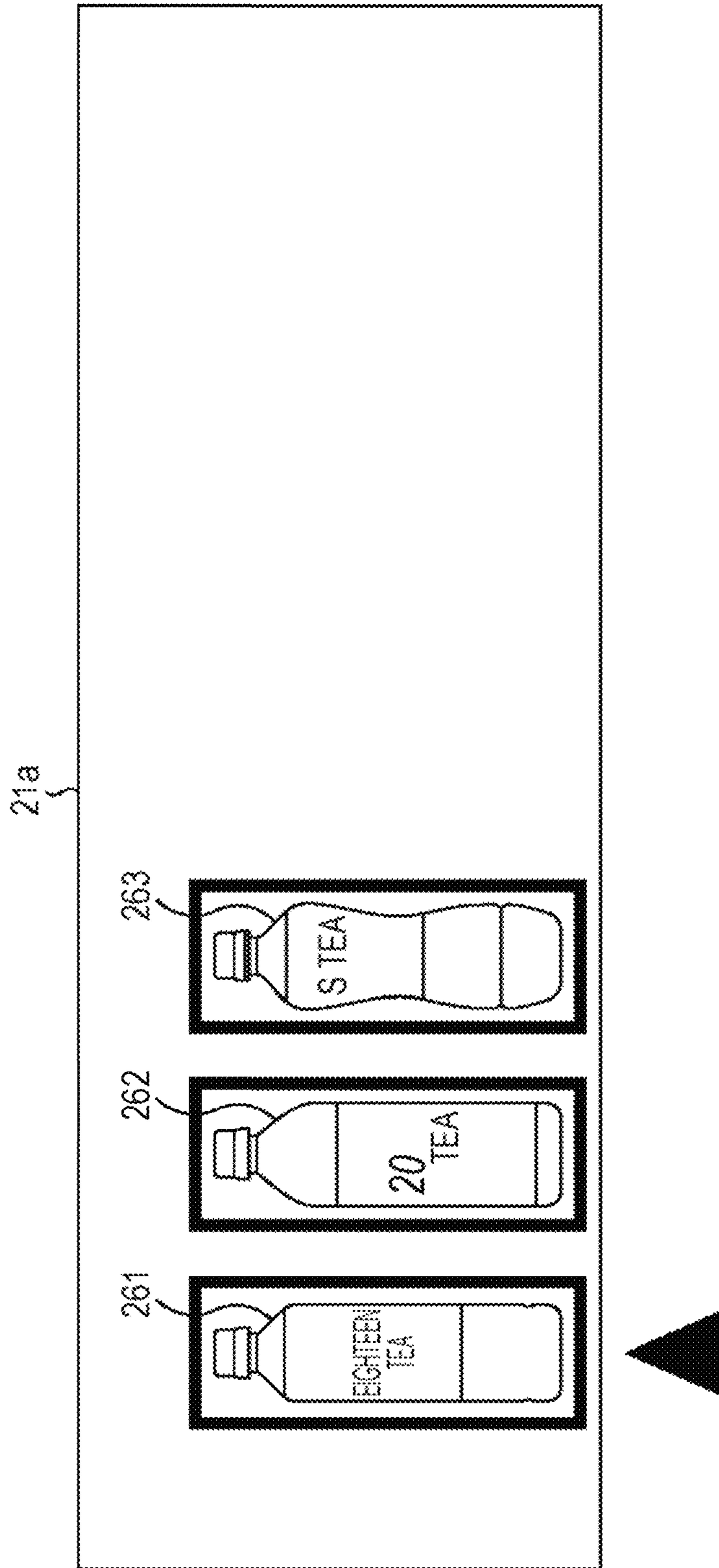

FIG. 43

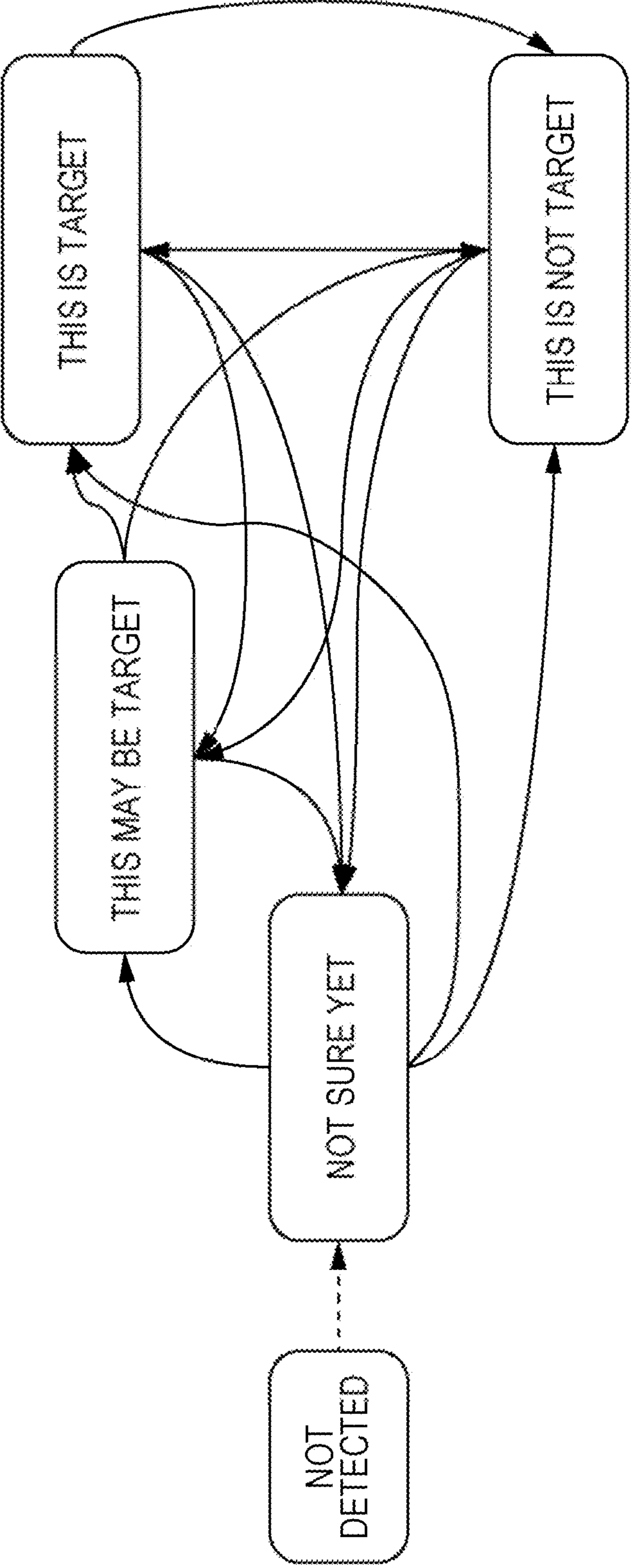

FIG. 44

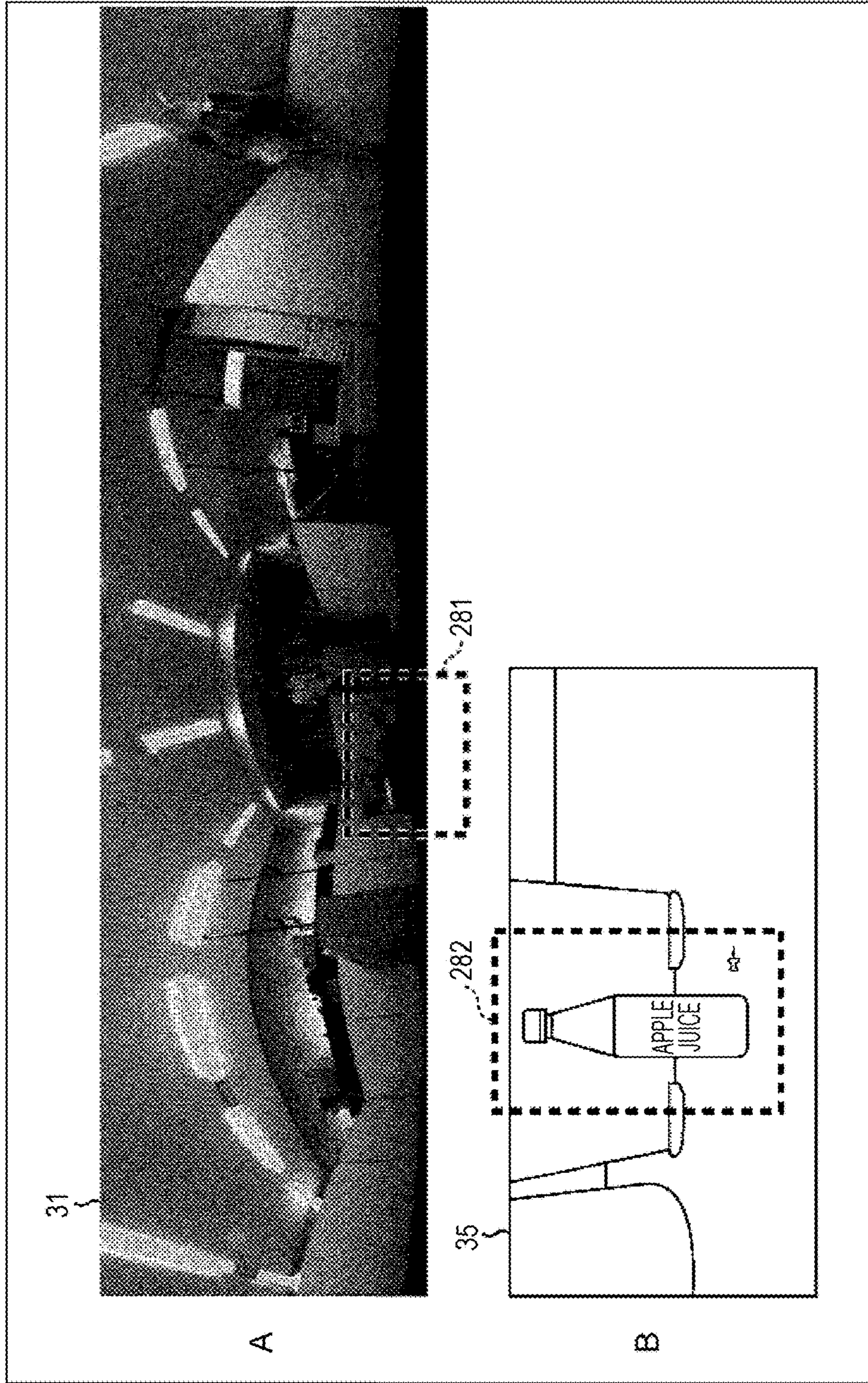

FIG. 45

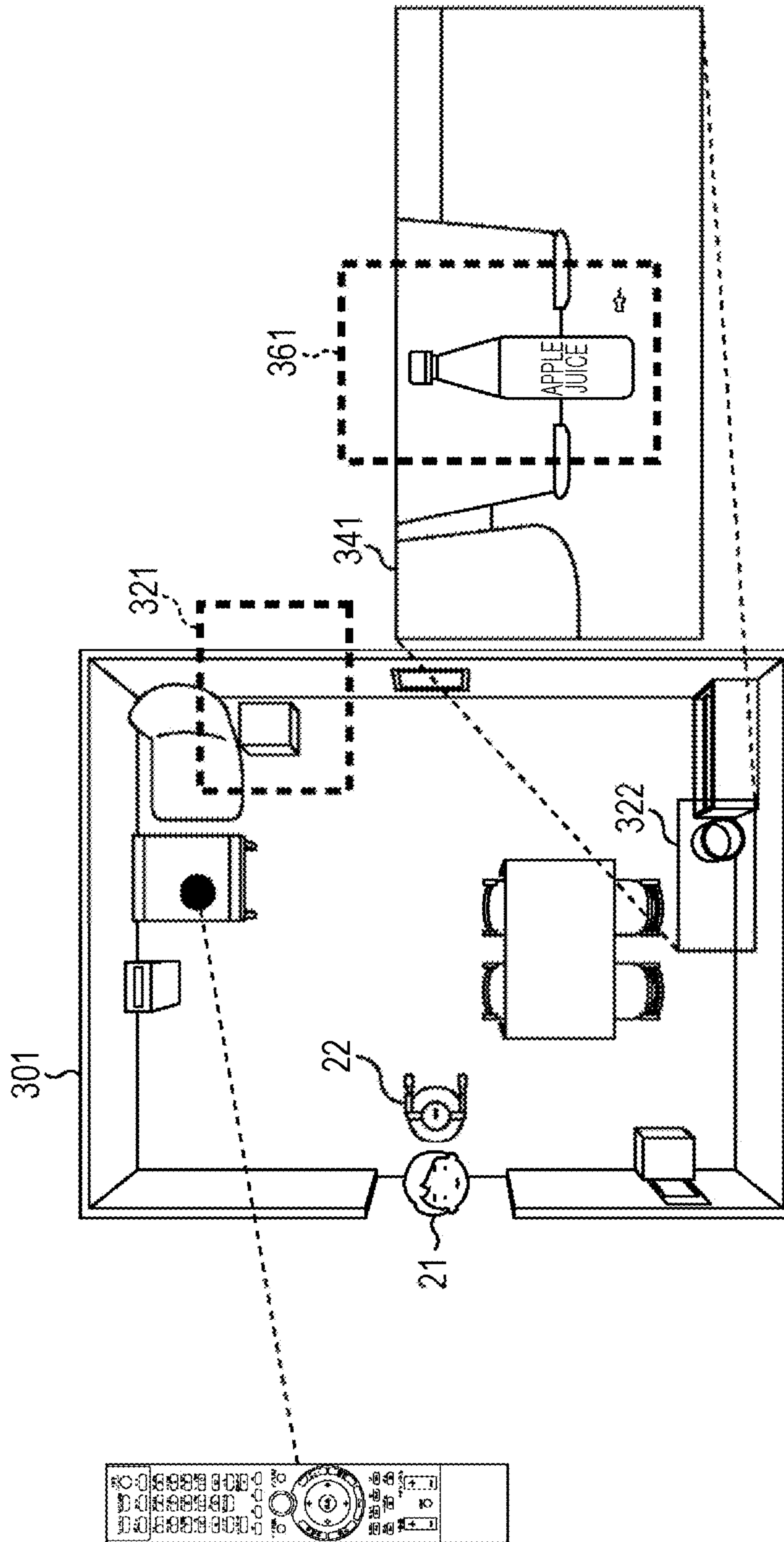

FIG. 46

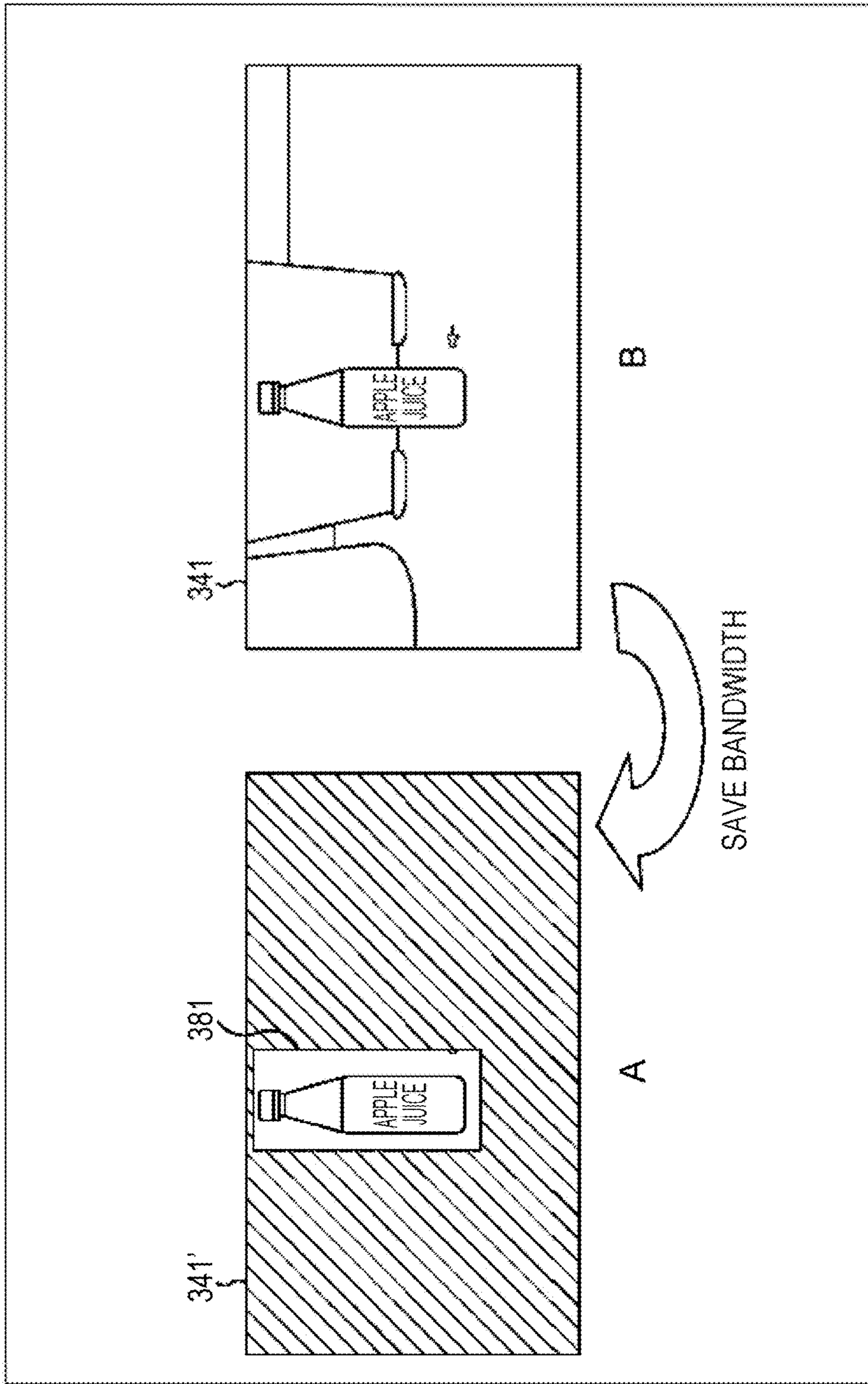

FIG. 47

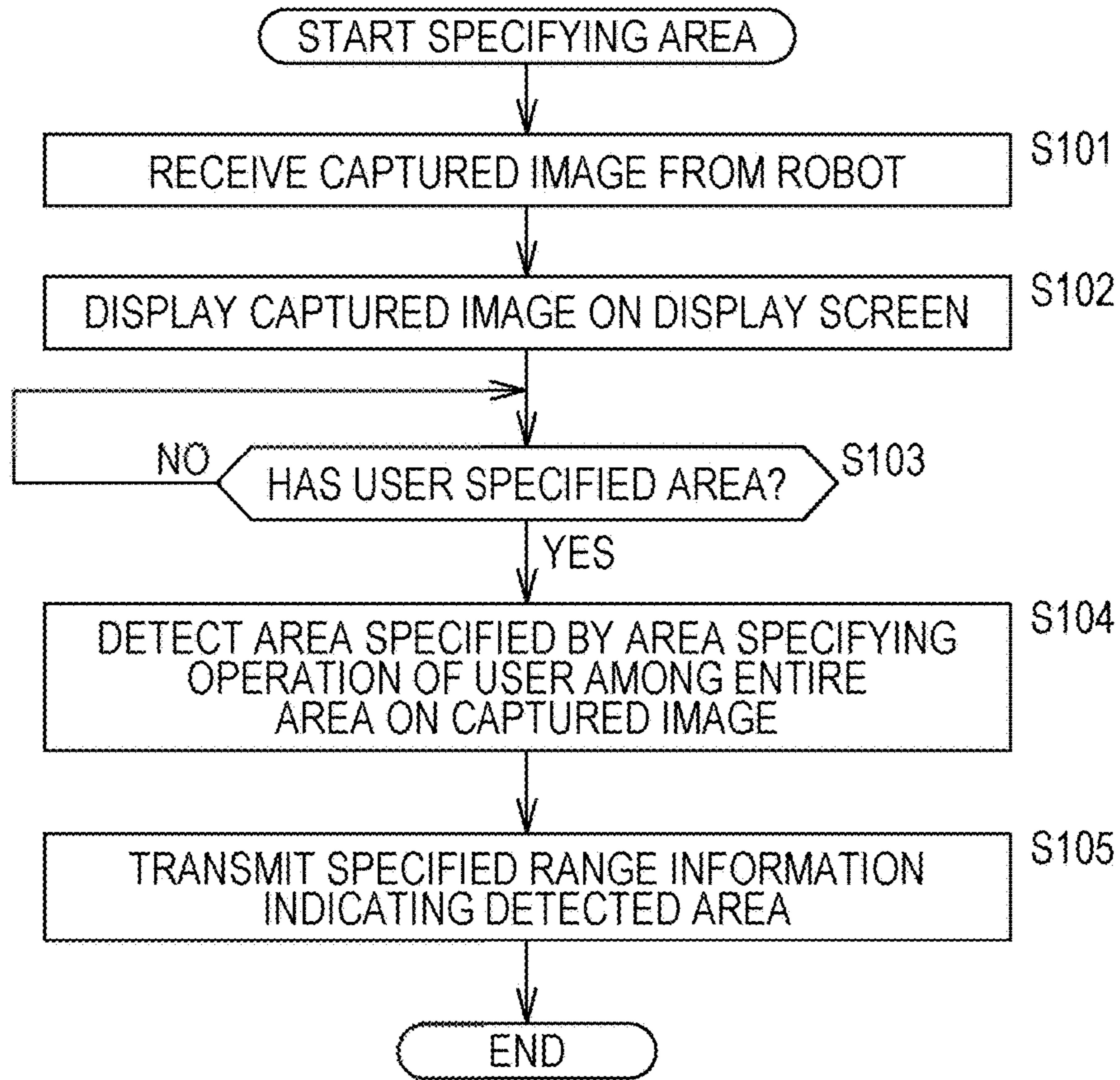

FIG. 48

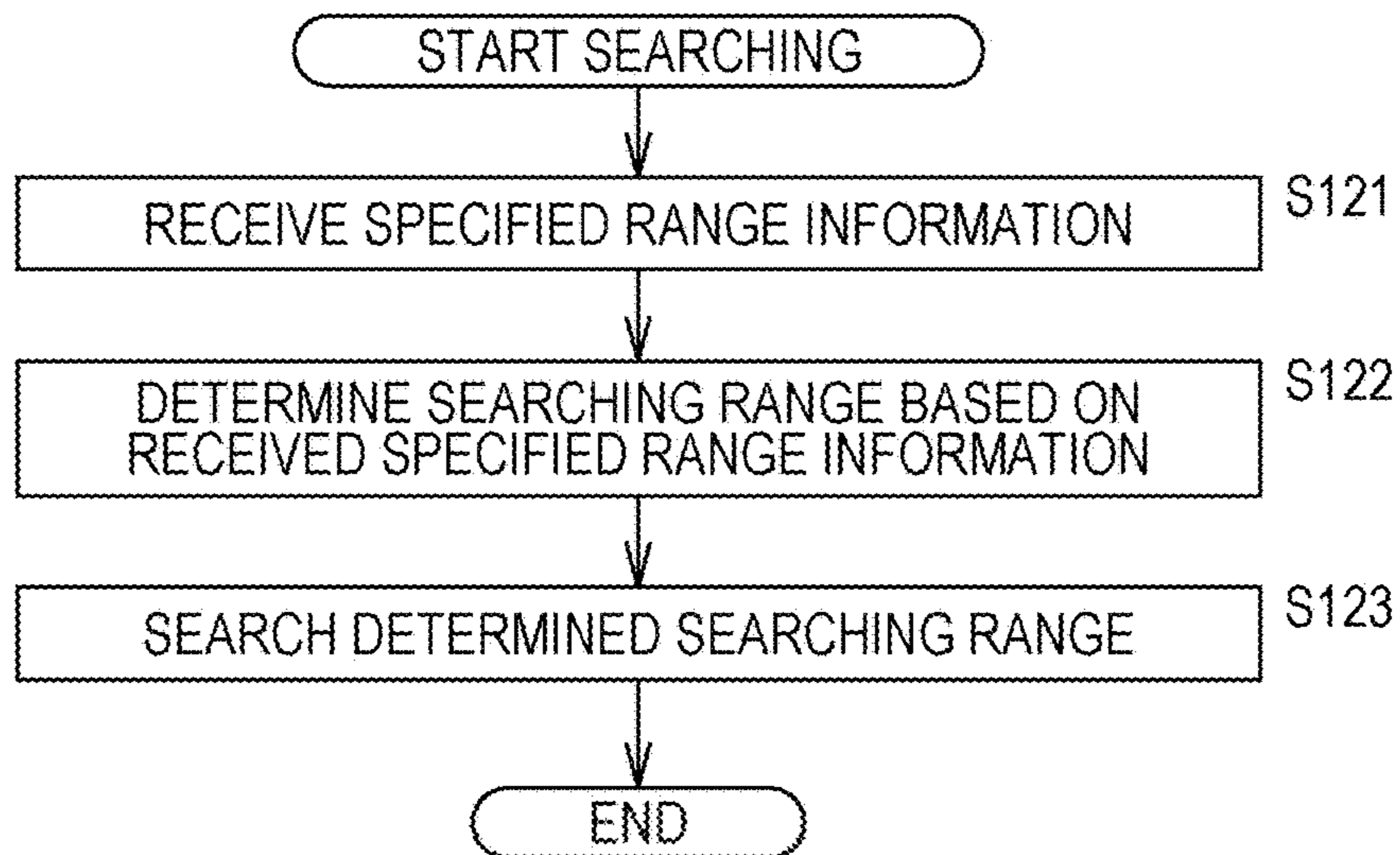
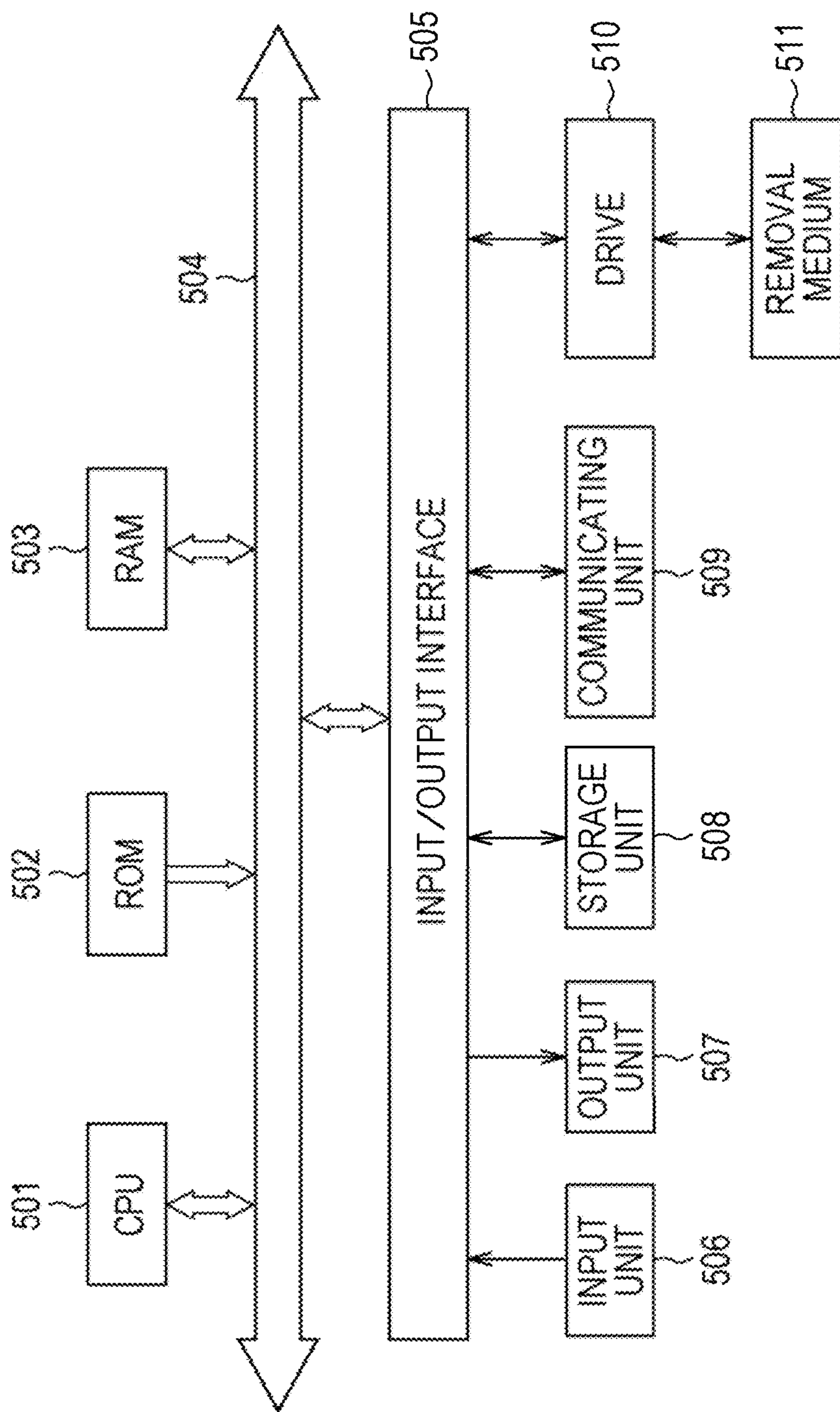

FIG. 49



**CONTROL DEVICE, CONTROL METHOD,
COMPUTER PROGRAM PRODUCT, AND
ROBOT CONTROL SYSTEM**

CROSS-REFERENCE TO RELATED
APPLICATIONS

This application is a continuation of U.S. application Ser. No. 14/234,658, filed Jan. 24, 2014, which is a National Stage of PCT/JP2012/004745 filed Jul. 25, 2012 and claims the benefit of priority under 35 U.S.C. § 119 of Japanese Application No. 2011-168923, filed Aug. 2, 2011. The entire contents of which are incorporation herein by reference.

TECHNICAL FIELD

The present disclosure relates to a control device, a control method, a computer program product, and a robot control system, for example, a control device, a control method, a computer program product, and a robot control system that allow an autonomous robot to search a search range designated by a user.

BACKGROUND ART

For example, generally, an autonomous robot autonomously acts (operates) in accordance with surroundings or general instruction from a user.

For example, if a user orders to bring a PET bottled tea without specifying a brand name, the autonomous robot autonomously performs an action that searches and brings a PET bottled tea in accordance with the instruction.

That is, for example, when the autonomous robot finds a plurality of PET bottled teas, the autonomous robot selects a user-preferred PET bottled tea at its own judgment and brings the tea to the user.

Further, there is a technology with which in accordance with designation of goods and the destination of the goods, the user allows the robot to move the goods to the destination (see, for example, Patent Document 1).

CITATION LIST

Patent Document

Patent Document 1: Japanese Patent Application Laid-Open No. 2004-268148

SUMMARY

Note that, for example, since the autonomous robot autonomously behaves, the robot may pass the search range that the user desires and search a wrong range in some cases.

Therefore, for example, it is preferable that the user designates the search range and allow the autonomous robot to search the designated search range.

The present disclosure has been made to consider the above problems and enables the autonomous robot to designate the search range by a simple operation.

Solutions to Problems

According to an exemplary control system for an autonomous robot aspect of the present disclosure, the system includes

a communications interface that exchanges information with the autonomous robot;

a user interface that displays a scene of a location in which the autonomous robot is positioned, and receives an indication of a user selection of a user selected area within the scene, wherein

5 the communications interface transmits an indication of the user selected area to the autonomous robot for further processing of the area by the autonomous robot.

According to another aspect the system further includes a display, wherein

10 the scene is displayed on the display and includes a space diagram of a room and the user selected area is a partial area of the room, the space diagram including objects in the room.

According to another aspect, the system further includes
15 a receiver that receives images from the autonomous robot; and

the autonomous robot, wherein the autonomous robot transmits a second image of the user selected area after transmitting a higher quality image used for selection of the
20 user selected area.

According to another aspect, the system further includes at least one of a tablet computer and a smartphone that includes the communications interface and a display.

According to another aspect, the system further includes
25 a control unit that generates the indication of the user selected area in response to receiving the indication of the user selection.

According to another aspect,

30 the autonomous robot is configured to detect a smaller area within the user selected area based on further user input transmitted from the communications interface.

According to another aspect,

35 the autonomous robot is configured to transmit specified range information that indicates the smaller area that is detected.

According to another aspect,
the scene is a captured image.

According to another aspect,
the scene is a computer generated graphic.

40 According to another aspect,
the user interface is configured to receive as input a category of a target object within the scene.

the communications interface transmits an indication of the category of target object to the autonomous robot, and
45 the autonomous robot attempts to identify within the scene one of more target objects in the category.

According to another aspect,
the autonomous robot assigns degree information for candidate target objects, the degree information being an
50 indication of a likelihood of correct detection of respective target objects in the category.

According to another aspect,

55 the user interface is configured to receive voice or gesture input commands.

Effects

60 According to the present disclosure, it is possible to designate the search range by the autonomous robot by the simple operation.

BRIEF DESCRIPTION OF DRAWINGS

65 FIG. 1 is a view illustrating a configuration example of a robot control system according to the present disclosure.

FIG. 2 is a view illustrating an example of a display screen on which a plurality of items is displayed.

3

FIG. 3 is a view explaining an outline of processing carried out by a robot.

FIG. 4 is a view illustrating an example of a recognition status of an object.

FIG. 5 is a block diagram illustrating a configuration example of an instructing device.

FIG. 6 is a first view illustrating an example of a display screen on which a display based on information from a robot is displayed.

FIG. 7 is a second view illustrating an example of a display screen on which a display based on information from a robot is displayed.

FIG. 8 is a third view illustrating an example of a display screen on which a display based on information from a robot is displayed.

FIG. 9 is a fourth view illustrating an example of a display screen on which a display based on information from a robot is displayed.

FIG. 10 is a fifth view illustrating an example of a display screen on which a display based on information from a robot is displayed.

FIG. 11 is a sixth view illustrating an example of a display screen on which a display based on information from a robot is displayed.

FIG. 12 is a seventh view illustrating an example of a display screen on which a display based on information from a robot is displayed.

FIG. 13 is an eighth view illustrating an example of a display screen on which a display based on information from a robot is displayed.

FIG. 14 is a ninth view illustrating an example of a display screen on which a display based on information from a robot is displayed.

FIG. 15 is a first view illustrating an example where the change in scores of an object is denoted by arrows.

FIG. 16 is a second view illustrating an example where the change in scores of an object is denoted by arrows.

FIG. 17 is a tenth view illustrating an example of a display screen on which a display based on information from a robot is displayed.

FIG. 18 is a flowchart for explaining display processing carried out by an instructing device.

FIG. 19 is a block diagram illustrating a configuration example of a robot.

FIG. 20 is a state transition diagram illustrating an example of transition of a recognition status of an object.

FIG. 21 is a view for explaining a creating method that creates robot recognition information in accordance with a recognition status of an object.

FIG. 22 is a flowchart for explaining score calculation processing carried out by a robot.

FIG. 23 is an eleventh view illustrating an example of a display screen on which a display based on information from a robot is displayed.

FIG. 24 is a twelfth view illustrating an example of a display screen on which a display based on information from a robot is displayed.

FIG. 25 is a thirteenth view illustrating an example of a display screen on which a display based on information from a robot is displayed.

FIG. 26 is a fourteenth view illustrating an example of a display screen on which a display based on information from a robot is displayed.

FIG. 27 is a fifteenth view illustrating an example of a display screen on which a display based on information from a robot is displayed.

4

FIG. 28 is a sixteenth view illustrating an example of a display screen on which a display based on information from a robot is displayed.

FIG. 29 is a seventeenth view illustrating an example of a display screen on which a display based on information from a robot is displayed.

FIG. 30 is an eighteenth view illustrating an example of a display screen on which a display based on information from a robot is displayed.

FIG. 31 is a view for explaining a feedback operation by a user.

FIG. 32 is a view illustrating an example where a recognition status of an object is transited in response to the feedback operation.

FIG. 33 is a nineteenth view illustrating an example of a display screen on which a display based on information from a robot is displayed.

FIG. 34 is a twentieth view illustrating an example of a display screen on which a display based on information from a robot is displayed.

FIG. 35 is a twenty-first view illustrating an example of a display screen on which a display based on information from a robot is displayed.

FIG. 36 is a twenty-second view illustrating an example of a display screen on which a display based on information from a robot is displayed.

FIG. 37 is a twenty-third view illustrating an example of a display screen on which a display based on information from a robot is displayed.

FIG. 38 is a twenty-fourth view illustrating an example of a display screen on which a display based on information from a robot is displayed.

FIG. 39 is a flowchart for explaining feedback processing carried out by an instructing device.

FIG. 40 is a flowchart for explaining score recalculation processing carried out by a robot.

FIG. 41 is a twenty-fifth view illustrating an example of a display screen on which a display based on information from a robot is displayed.

FIG. 42 is a twenty-sixth view illustrating an example of a display screen on which a display based on information from a robot is displayed.

FIG. 43 is a view illustrating an example where non-detected recognition state is transited into another state.

FIG. 44 is a view illustrating an example where a searching range or an object is specified using a captured image.

FIG. 45 is a view illustrating an example where a searching range is specified using an indoor space diagram.

FIG. 46 is a view illustrating an example where an amount of data of a captured image transmitted from a robot to an instructing device is reduced.

FIG. 47 is a flowchart for explaining area specification processing carried out by an instructing device.

FIG. 48 is a flowchart for explaining search processing carried out by a robot.

FIG. 49 is a block diagram illustrating a configuration example of a computer.

MODE FOR CARRYING OUT THE INVENTION

Hereinafter, embodiments of the present disclosure (hereinafter, referred to as the present embodiment) will be described in the following order.

1. First embodiment (an example where information for predicting behavior of a robot is displayed on a display screen of an instructing device)

2. Modified example of the first embodiment

5

3. Second embodiment (an example where a feedback from a user is given to the robot using an instructing device)

4. Modified example of the second embodiment

5. Third embodiment (an example where a searching range of the robot is specified using an instructing device)

1. First Embodiment

[Configuration Example of Robot Control System]

FIG. 1 illustrates a configuration example of a robot control system 1 according to a first embodiment.

The robot control system 1 includes an instructing device 21 having a display screen 21a, and an autonomous robot 22. The instructing device may be a remote controller with a display screen integrated into the remote controller (e.g., a smartphone, tablet computer, or laptop computer) or a remote controller that operates wirelessly with a remote display device. For example, the instructing device, may use a television as the display device, and the instructing device serves as the tactile interface for inputting instructions.

The instructing device 21 generates instruction information for causing the robot 22 to do desired behavior (for example, behavior of bringing a predetermined object to a user) in response to manipulation of the user and transmits the information to the robot 22 through wireless communication or the like. Moreover, the robot 22 may interact with the predetermined object where interact is not just taking images of the object, but also contact, move, collect, perform electronic exchange of information with, optical character recognition of, illuminate, purchase, label, or operate (such as turn on/off) the object.

For example, the instructing device 21, as shown in FIG. 2, displays a plurality of items such as “tea”, “soda”, “snack”, . . . which may be selected by a user on the display screen 21a.

With reference to the display screen 21a as shown in FIG. 2, among the plurality of items, the user selects (specifies) an item of object to be brought by the robot 22. Further, for example, a category of the objects to be brought by the robot 22 is displayed on the display screen 21a as the items.

In response to this, the instructing device 21 creates instruction information for bringing, as the target, the object belonging to the category (for example, “tea”) as the item selected by the user to the user and transmits the information to the robot 22 by the wireless communication or the like. Further, the instruction information includes category information that represents categories as the items selected by the user.

The robot 22 autonomously performs an operation of searching, as the target, the object belonging to the category as the item selected by the user based on the instruction information from the instructing device 21. The instructing device may be a remote controller with a display screen integrated into the remote controller (e.g., a smartphone, tablet computer, or laptop computer) or a remote controller that operates wirelessly with a remote display device. For example, the instructing device, may use a television as the display device, and the instructing device serves as the tactile interface for inputting instructions.

Further, a method for instructing the robot 22 is not limited to the above-mentioned method that uses the instructing device 21. For example, if the robot 22 may recognize a voice of the user by the voice recognition, the user may indicate the target using a voice. The instructing device may be a remote controller with a display screen integrated into the remote controller (e.g., a smartphone, tablet computer, or laptop computer) or a remote controller

6

that operates wirelessly with a remote display device. For example, the instructing device, may use a television as the display device, and the instructing device serves as the tactile interface for inputting instructions.

In this case, the robot 22 recognizes the instruction from the user as a voice, and autonomously performs an operation of searching the target indicated by the user based on the recognition result. Further, for example, if the robot 22 may recognize a gesture or posture of the user, the user may indicate the target by the gesture or posture.

The robot 22 is a two-legged robot that autonomously performs various actions based on the surroundings or general instruction from the user (for example, general instruction to bring “tea”).

The robot 22 includes, as sensors that sense stimulus from the outside, a microphone corresponding to “ears” that sense sounds, and a camera corresponding to “eyes” that sense light, which are provided in predetermined positions. The details of the robot 22 will be described below with reference to FIG. 19.

Next, FIG. 3 illustrates an outline of processing carried out by the robot 22.

FIG. 3 illustrates a surrounding image 31 obtained by capturing the surroundings of the robot 22, an object image 32 that indicates an object which is recognized as a target by the robot 22, an object image 33 that indicates an object which is not recognized as a target by the robot 22, an object image 34 that indicates an object which is recognized as a possible target by the robot 22, and a partial image 35 that indicates a part of a captured image obtained by capturing of the robot 22. Additionally, the scene provided by the robot 22 (or pre-stored in the controller 21), may be a computer generated graphic that includes objects within the scene, such as furniture. Thus, an image and a computer generated graphic are two examples of a scene.

Further, the robot 22 freely moves, for example, in a room 36 in which the user resides to search a target.

While searching the target, the robot 22 appropriately transmits the surrounding image 31 or the partial image 35 obtained by capturing with a built-in camera to the instructing device 21. Further, the surrounding image 31 or the partial image 35 is used when the user specifies the searching range of the robot 22 using the instructing device 21. This will be mainly described with reference to FIGS. 43 to 47.

Further, the robot 22 moves in the room 36 and calculates a score that indicates a degree that the object is the target, that is, a degree that the object is a subject to be processed by the robot 22, based on the captured image obtained by capturing the object with the built-in camera. In addition, an identifier for identifying (a function indicating) whether the object is the target is used to calculate the score.

The robot 22 determines the recognition status of the object based on the score of the object. Further, hereinafter, it is described that the robot 22 uses the image obtained using the built-in camera to calculate the score or transmits the image to the instructing device 21.

However, the image used to calculate the score or the image transmitted to the instructing device 21 is not limited to the image obtained by the built-in camera in the robot 22. For example, an image obtained by a camera provided on the ceiling of the room 36 may be used. In this case, the camera provided on the ceiling of the room 36 transmits the captured image to the robot 22 by the wireless communication. Additionally, the scene provided by the robot 22 (or pre-stored in the controller 21), may be a computer generated

graphic that includes objects within the scene, such as furniture. Thus, an image and a computer generated graphic are two examples of a scene.

Next, FIG. 4 illustrates an example of the recognition status.

FIG. 4A illustrates two kinds of the recognition statuses of the robot 22, which are “this is a target” and “this is not a target”.

FIG. 4B illustrates three kinds of the recognition statuses of the robot 22, which are “this is a target”, “not sure yet”, and “this is not a target”.

FIG. 4C illustrates four kinds of the recognition statuses of the robot 22, which are “this is a target”, “this may be a target”, “not sure yet”, and “this is not a target”.

Further, in the first embodiment, as shown in FIG. 4C, the robot 22 recognizes any one of the four recognition statuses.

For example, if the score of the object is equal to or higher than a threshold th1, the robot 22 recognizes that the object “is a target”. If the score of the object is lower than the threshold th1 and equal to or higher than a threshold th2 (<th1), the robot 22 recognizes that the object “may be a target”.

Further, if the score of the object is lower than the threshold th2 and equal to or higher than a threshold th3 (<th2), the robot 22 recognizes the object as “not sure yet” whether the object is a target. If the score of the object is lower than the threshold th3, the robot 22 recognizes that the object “is not a target”.

Here, the thresholds th1 to th3 are previously determined and then stored in the robot 22. Further, the robot 22 compares the score with the threshold in order to determine the recognition information of the object, but the method of determining the recognition information is not limited thereto.

Referring back to FIG. 3, for example, if it is judged that the score of the object “ABC tea” is equal to or higher than the threshold th1, the robot 22 displays on the display screen 21a of the instructing device 21 that the robot 22 recognizes that the object “ABC tea” “is a target”.

That is, for example, as shown in FIG. 3, on the display screen 21a of the instructing device 21, the object image 32 indicating the object “ABC tea” is displayed in a state enclosed by, for example, a heavy-lined rectangle. The heavy-lined rectangle indicates that the robot 22 recognizes that the object “ABC tea” is “a target”.

Further, for example, as shown in FIG. 3, if it is judged that a score of an object “dog-shaped robot” is lower than the threshold th3, the robot 22 displays on the display screen 21a of the instructing device 21 that the robot 22 recognizes that the object “dog-shaped robot” is “not a target”.

That is, for example, as shown in FIG. 3, on the display screen 21a of the instructing device 21, the object image 33 indicating the object “dog-shaped robot” is displayed with, for example, hatched lines. The hatched lines indicate that the robot 22 recognizes that the object “dog-shaped robot” is “not a target”.

Further, for example, as shown in FIG. 3, if it is judged that a score of an object “orange juice” is lower than the threshold th1 and equal to or higher than the threshold th2, the robot 22 displays on the display screen 21a of the instructing device 21 that the robot 22 recognizes that the object “orange juice” “may be a target”.

That is, for example, as shown, in FIG. 3, on the display screen 21a of the instructing device 21, the object image 34 indicating a PET bottle on which the text “orange juice” is written is displayed in a state enclosed by, for example, a

thin-lined rectangle. The thin-lined rectangle indicates that the robot 22 recognizes that the object “orange juice” “may be a target”.

Further, for example, if it is judged that a score of a predetermined object is lower than the threshold th2 and equal to or higher than the threshold th3, the robot 22 displays on the display screen 21a of the instructing device 21 that the robot 22 recognizes that it is “not sure yet” whether the predetermined object is a target.

That is, (or example, on the display screen 21a of the instructing device 21, the object image indicating the predetermined object is displayed as it is (not enclosed by a rectangle or without hatched lines). When the object image is displayed as it is, this indicates that the robot 22 is “not sure yet” whether the predetermined object is a target.

As described above, the information recognized by the robot 22 is displayed on the display screen 21a of the instructing device 21 so that the user may easily predict the behavior of the robot 22.

However, the display method is not limited thereto, but as long as the user instinctively figures out the behavior of the robot 22, any display method may be used.

Further, by referring to the display screen 21a, if it is judged that an object that is not desirable as a target is recognized as a target, the user may give a feedback manipulation indicating that the object is not a target to the instructing device 21.

In this case, the robot 22 recalculates the scores of the object in response to the feedback manipulation of the user, and autonomously behaves based on the score obtained by the recalculation. Further, the feedback manipulation of the user will be described below mainly with reference to FIGS. 31 to 42.

[Configuration Example of Instructing Device 21]

Next, FIG. 5 illustrates the configuration example of the instructing device 21.

The instructing device 21 includes a manipulating unit 41, a control unit 42, a display unit 43 having a display screen 21a, a communicating unit 44, and a storage unit 45.

The manipulating unit 41 includes manipulating keys or manipulating buttons. For example, if the user gives an instruction to the robot 22, the manipulating unit is manipulated by the user. When the manipulating unit 41 is manipulated by the user, the manipulating unit 41 supplies a manipulating signal corresponding to the manipulation of the user to the control unit 42.

The control unit 42 creates a robot recognition image including an object image based on the robot recognition information from the communicating unit 44 and supplies the image to the display unit 43 to display the image on the display screen 21a. Further, the robot recognition information includes, for example, scores of the objects as information required to display on the display screen 21a. In addition, the display example of the display screen 21a will be described below with reference to FIGS. 6 to 17.

Further, the control unit 42 creates instruction information, feedback information, or specified range information based on the manipulating signal from the manipulating unit 41 and supplies the information to the communicating unit 44.

Here, the feedback information refers to information indicating contents fed back by the user in the instructing device 21.

The user uses the manipulating unit 41, for example, to feedback that the object recognized “as a target” by the robot 22 is not a target. This will be described below with reference to FIGS. 31 to 42.

Further, the specified range information indicates, for example, the position of an area specified by the area specification of the user among the entire area on the surrounding image **31** or the partial image **35** displayed on the display screen **21a** of the instructing device **21**.

The user uses the manipulating unit **41**, for example, to perform an area specification for specifying the searching range where the robot **22** searches the target among the entire area on the surrounding image **31** or the partial image **35**. This will be described below with reference to FIGS. **43** to **47**.

The control unit **42** supplies robot recognition information from the communicating unit **44** to the storage unit **45** to be stored therein.

The display unit **43** displays the images on the display screen **21a** in accordance with the control from the control unit **42**.

Further, although the instructing device **21** is configured to include the display unit **43**, for example, the display unit **43** may not be included in the instructing device **21**. In this case, the control unit **42** and the display unit **43** that is provided in the outside are connected by a cable.

The communicating unit **44** receives the robot recognition information transmitted from the robot **22** and supplies the information to the control unit **42**. Further, the communicating unit **44** transmits the instruction information, the feedback information, or the specified range information from the control unit **42** to the robot **22** using wireless communication or the like.

The storage unit **45** stores, for example, a control program which is executed by the control unit **42** in advance. Further, for example, the storage unit **45** stores the robot recognition information from the control unit **42**.

[Display Example of Display Screen **21a**]

Next, FIGS. **6** to **14** illustrate an example of the display screen **21a** when the instructing device **21** displays the robot recognition image based on the robot recognition information from the robot **22**.

If the robot **22** is instructed to bring an object “tea” based on the instruction information from the instructing device **21**, the robot **22** goes to search the object “tea”.

When the robot **22** explores the room but does not detect the object, the robot recognition information from the robot **22** is not transmitted to the instructing device **21**.

Therefore, as shown in FIG. **6**, the control unit **42** displays a robot recognition image in which nothing is captured on the display screen **21a**, for example.

When the robot **22** detects an object “bird figurine” from the captured image obtained by capturing the inside of the room **36**, the robot **22** extracts an object image **51** representing the object “bird figurine” from the captured image and adds the object image **51** to the robot recognition information to transmit the information to the communicating unit **44**.

In response to this, the communicating unit **44** supplies the robot recognition information from the robot **22** to the control unit **42**. The control unit **42** supplies the object image **51** included in the robot recognition information from the communicating unit **44** to the display unit **43** to display the object image **51** on the display screen **21a**.

As a result, the object image **51**, as shown in FIG. **7**, is displayed on the display screen **21a** at the left side of the drawing. Therefore, the user may easily predict that the robot **22** detects the bird figurine as an object.

The robot **22** approaches the object “bird figurine” in order to discriminate whether the object “bird figurine” is a target. Then, the robot **22** extracts the object image **51**

representing the “bird figurine” from a captured image obtained by approaching and capturing the object “bird figurine” and adds the object image **51** to the robot recognition information to transmit the information to the communicating unit **44**.

In response to this, the communicating unit **44** supplies the robot recognition information from the robot **22** to the control unit **42**. The control unit **42** supplies the object image **51** included in the robot recognition information from the communicating unit **44** to the display unit **43** to display the object image **51** on the display screen **21a**.

As a result, as shown in FIG. **8**, the object image **51** which is larger than that in FIG. **7** is displayed on the display screen **21a** at the left side of the drawing. Further, since the score of the object “bird figurine” has not been calculated yet, the robot **22** is “not sure yet” whether the object “bird figurine” is a target. Therefore, in FIG. **8**, the object image **51** is displayed as it is (not enclosed by a rectangle or without hatched lines)

The robot **22** calculates a score of the object “bird figurine” from the captured image obtained by approaching and capturing the object “bird figurine”. Further, when the robot **22** recognizes that the object “bird figurine” is “not a target” based on the calculated score, the robot **22** transmits, to the communicating unit **44**, the robot recognition information including (information indicating) a recognition status indicating that “the object is not a target”.

In response to this, the communicating unit **44** supplies the robot recognition information from the robot **22** to the control unit **42**. The control unit **42** creates the object image **51** with hatched lines based on the recognition status included in the robot recognition information from the communicating unit **44** and supplies the object image **51** to the display unit **43** to be displayed on the display screen **21a**.

As a result, as shown in FIG. **9**, the object image **51** with the hatched lines is displayed on the display screen **21a**.

Further, the hatched lines added to the object image **51** represent that the robot **22** recognizes that the object “bird figurine” on the object image **51** is “not a target”.

Therefore, the user may easily predict that the robot **22** recognizes that the “bird figurine” on the object image **51** is “not a target”.

When the robot **22** detects an object “eighteen tea” from the captured image obtained by capturing the room, the robot **22** extracts an object image **52** representing the object “eighteen tea” from the captured image.

The robot **22** transmits the robot recognition information including the extracted object image **52** to the communicating unit **44**.

In response to this, the communicating unit **44** supplies the robot recognition information from the robot **22** to the control unit **42**. The control unit **42** supplies the object image **52** included in the robot recognition information from the communicating unit **44** to the display unit **43** to display the object image **52** on the display screen **21a**.

As a result, as shown in FIG. **10**, the object image **52** of the object “eighteen tea” detected by the robot **22** is displayed on the display screen **21a** at the left side of the drawing. Therefore, the user may easily predict that the robot **22** detects the object “eighteen tea”.

Further, the robot **22** calculates a score of the object “eighteen tea” from the captured image obtained by approaching and capturing the object “eighteen tea”. When the robot **22** recognizes that the object “eighteen tea” is “a target” based on the calculated score, the robot **22** transmits, to the communicating unit **44**, the robot recognition infor-

11

mation including a recognition status indicating that the object “eighteen tea” is “a target”.

In response to this, the communicating unit 44 supplies the robot recognition information from the robot 22 to the control unit 42. The control unit 42 creates the object image 52 enclosed by a rectangle and indicated by a triangle and the object image 51 with hatched lines based on the robot recognition information from the communicating unit 44 and supplies the object images 52 and to the display unit 43 to be displayed on the display screen 21a.

As a result, as shown in FIG. 11, the object image 52 enclosed by a heavy-lined rectangle and indicated by a triangle (▲ shown in FIG. 11) is displayed on the display screen 21a at the left side of the drawing and the object image 51 with hatched lines is displayed at the further right than the object image 52.

Further, the heavy-lined rectangle that encloses the object image 52 indicates that the robot 22 recognizes the object “eighteen tea” of the object image 52 as “a target”. In addition, the triangle indicating the object image 52 indicates that the robot 22 will return with the object “eighteen tea” of the object image 52.

Further, in this case, the control unit 42 allows the object images indicating the objects to be displayed from the left to the right direction of the display screen 21a in the order of higher scores of the objects.

In addition, the display position of the object image corresponds to the score of the object. Therefore, for example, the displaying interval between a first object image and a second object image indicates the difference in score between the objects of the first object image and the second object image.

Accordingly, the user may instinctively notice the score of the object indicated by the object image in accordance with the position of the object image displayed on the display screen 21a.

From the display screen 21a shown in FIG. 11, the user may easily predict that the robot 22 brings the object “eighteen tea”.

Further, when the robot 22 autonomously moves and detects a new object from the captured image obtained by capturing using the built-in camera, as described above, the robot 22 creates robot recognition information and transmits the information to the communicating unit 44.

In response to this, the control unit 42 supplies an object image to the display unit 43 to display the object image on the display screen 21a based on the robot recognition information from the communicating unit 44.

As described above, the control unit 42 updates the display of the display screen 21a based on the robot recognition information transmitted from the robot 22 through the communicating unit 44.

That is, thereafter, for example, the display screen 21a, as shown in FIG. 12, is updated to newly display an object image 53 representing an object “ABC tea” in response to the behavior of the robot 22. Further, the display screen 21a, as shown in FIG. 13, is updated to newly display an object image 54 representing an object “C soda juice” and an object image 55 representing an object “USB memory” in response to the behavior of the robot 22. In addition, for example, the display screen 21a, as shown in FIG. 14, is updated to the one in which the positions of the object images are changed in accordance with the scores in response to the behavior of the robot 22.

Further, on the display screen 21a of FIG. 14, the object image 51 that is displayed on the display screen 21a of FIG. 13 is not displayed.

12

In FIG. 14, as an object is displayed on the farther left side of the display screen 21a, the score of the object is higher. Therefore, the score of the object may be represented by the position at which the object image is displayed.

Therefore, when the object images 52 to 55 are displayed in positions according to the scores of the corresponding objects, the object image 51 may not be displayed due to the size of the display screen 21a or the object images.

Further, in FIG. 14, the score of the object “bird figurine” of the object image 51 is set to be significantly lower than the score of the object “USB memory” of the object image 55.

In addition, in FIG. 14, the score of the object “ABC tea” of the object image 53 is set to be lower than the score of the object “eighteen tea” of the object image 52.

However, the triangle indicates the object “ABC tea” of the object image 53 and the robot 22 intends to return with the object “ABC tea”. This means that the robot 22 determines an object to bring in consideration of the position of the object or a user’s preference in addition to the score of the object.

Note that, in the first embodiment, as shown in FIGS. 6 to 14, the object images are displayed in the order of higher scores of the objects from the left to the right of the display screen 21a side by side. However, the object images may be displayed in an arbitrary direction other than the rightward direction (for example, right to left direction).

Further, for example, in the first embodiment, as shown in FIGS. 6 to 14, the object images are displayed in the order of higher scores of the objects in an arbitrary direction side by side, and the object images are also displayed at positions corresponding to the scores of the objects.

However, the object images may be displayed on the display screen 21a only using the order of the scores. Alternatively, for example, the object images may be displayed on the display screen 21a at positions corresponding to the scores of the objects without using the order of the scores.

Further, for example, the object images may be displayed by changing at least one of the order, the position, the size, the brightness, the definition, and the color of the object images in accordance with the scores of the objects.

In addition, for example, the scores of the objects may be displayed in association with the object images. Also, the scores, for example, may be represented by a bar graph or a circle graph. When the score is represented by the circle graph, a percentage for a score of an object having the highest score may be represented in the circle graph.

Further, for example, the changes in the scores of the objects may be represented by an arrow in the display screen 21a.

Specifically, for example, as shown in FIG. 15, if the score of the object “C soda juice” corresponding to the object image 54 is changed to be increased, a white arrow indicating the increase in the score of the object “C soda juice” is associated with the object image 54 and displayed on the display screen 21a.

Further, as shown in FIG. 15, if the score of the object “eighteen tea” corresponding to the object image 52 is changed to be decreased, a black arrow indicating the decrease in the score of the object “eighteen tea” is associated with the object image 52 and displayed on the display screen 21a.

In addition, for example, as shown in FIG. 15, if the score of the object “USB memory” corresponding to the object image 55 is changed to be decreased, a black arrow indi-

cating the decrease in the score of the object “USB memory” is associated with the object image **55** and displayed on the display screen **21a**.

When the contents as shown in FIG. **15** are displayed on the display screen **21a**, the user may predict that the robot **22** will not bring the object “eighteen tea”, but bring the object “C soda juice” by mistake. In this case, before the robot **22** brings the object “C soda juice” by mistake, the user may clearly instruct to bring, for example, the object “eighteen tea”.

Further, when the contents as shown in FIG. **16** are displayed on the display screen **21a**, the user may predict that the robot **22** will bring the object “eighteen tea” which is desired by the user. In this case, the user does not instruct the robot **22** and may focus on his/her job until the robot **22** brings the object “eighteen tea”. In addition, since FIG. **16** has the same configuration as FIG. **15**, the description of FIG. **16** will be omitted.

In addition, for example, on the display screen **21a**, the change in the scores of the objects may be represented by the bar graph or a line chart instead of an arrow. Alternatively, for example, together with the change in the scores of the objects, or instead of the change in the scores of the object, a history of the scores may be displayed.

When the change or the history of the scores is displayed, the user may figure out the change or the history of the scores of the objects by referring to the display screen **21a** and thus may easily predict the change in the ranking of the scores and eventually predict the behavior of the robot **22** in advance.

The above-mentioned display is realized by the control unit **42** referring to the robot recognition information stored in the storage unit **45**.

Further, if the ranking of the scores is changed in the instructing device **21**, the user may be notified of the change by sound, vibration, or blinking of a lamp.

In the first embodiment, as shown in FIGS. **6** to **14**, an object image of an object that is recognized “as a target” by the robot **22** is enclosed by a heavy-lined rectangle, and an object image of an object that is recognized “as a possible target” by the robot **22** is displayed as it is.

Further, for example, an object image of an object that is recognized, as “not sure yet” by the robot **22** is enclosed by a thin-lined rectangle, and an object image of an object that is recognized as “not a target” by the robot **22** is displayed with hatched lines.

However, the display method that represents the recognition statuses is not limited to the rectangle or the hatched lines.

Further, for example, both the display method that represents the recognition statuses and a display method that represents the scores of the objects may be used. Alternatively, only one of the display method that represents the recognition statuses and the display method that represents the scores of the objects may be used to display the object images on the display screen **21a**.

Next, FIG. **17** illustrates an example where detailed information of a selected object image is displayed as the user selects the object image on the display screen **21a**.

On the display screen **21a** shown in FIG. **17**, an object image **52a** indicating a bottom of the object “eighteen tea” (PET bottle), and object images **52b** to **52e** obtained by capturing the object “eighteen tea” from different directions as the detailed information of the object “eighteen tea” are displayed.

For example, the robot **22** extracts an object lineage from the latest captured image obtained by capturing the object as

an object image displayed on the display screen **21a** and adds the object image to the robot recognition information to transmit the information to the instructing device **21**.

Further, the robot **22** may use an object image extracted from a captured image having the highest resolution from a plurality of captured images in which the object is captured in addition to an object image extracted from latest captured image as an object image included in the robot recognition information.

In addition, as the object image included in the robot recognition information, among the plurality of object images, the robot **22** may use an extracted image that sufficiently represents the entire object or use a typical extracted image. Furthermore, as the typical extracted image, for example, an extracted image in which the object is captured at an angle of 45 degrees from above is considered.

For example, when the robot **22** obtains the captured image including parts of the object images **52b** to **52e** by the previous capturing, and obtains a captured lineage including a part of the object image **52a** by the latest capturing, the robot recognition image including the object image **52a** in which a bottom of the object “eighteen tea” is captured is transmitted to the instructing device **21**.

Further, in the instructing device **21**, as shown in FIG. **17**, the object image **52a** in which the bottom of the object “eighteen tea” is captured is displayed on the display screen **21a**. In this case, the user may not figure out that the object represented by the object image **52a** is the “eighteen tea” by watching the object image **52a** displayed on the display screen **21a**.

Therefore, the robot **22** transmits the robot recognition information including the object images **52b** to **52e** in addition to the object image **52a** to the communicating unit **44** of the instructing device **21**. In this case, the communicating unit **44** supplies the robot recognition information from the robot **22** to the control unit **42**.

The control unit **42** allows, as shown in FIG. **17**, an object image of an object “glue stick”, the object image **52a** of the object “eighteen tea”, and an object image of an object “wallet” to be displayed on the display screen **21a** of the display unit **43** from the left side of the drawing based on the robot recognition information from the communicating unit **44**.

Further, the control unit **42** supplies the robot recognition information from the communicating unit **44** to the storage unit **45** to be stored therein.

In the instructing device **21**, when the user selects the object image **52a** on the display screen **21a** using the manipulating unit **41**, the manipulating unit **41** supplies a manipulating signal corresponding to the selecting operation of the user to the control unit **42**.

Further, the control unit **42** reads the object images **52b** to **52e** included in the robot recognition information stored in the storage unit **45** in accordance with the manipulating signal from the manipulating unit **41** and supplies the images to the display unit **43** to be displayed on the display screen **21a**.

Accordingly, on the display screen **21a**, as shown in FIG. **17**, the object images **52b** to **52e** are displayed on the display screen **21a** as the detailed information of the object “eighteen tea”.

Therefore, even though the user cannot figure out the object on the object image **52a** from the object image **52a**, the user may easily figure out that the object captured in the

object image **52a** is the “eighteen tea” by the object images **52b** to **52e** displayed in response to the selecting operation of the user.

Further, for example, when the selecting operation of the user is performed in accordance with the manipulating signal from the manipulating unit **41**, the control unit **42** may display the enlarged object image **52a** as detailed information. In this case, for example, the control unit **42** reads the object image **52a** included in the robot recognition information stored in the storage unit and enlarges the object image with a predetermined enlargement ratio and displays the object on the display screen **21a**.

Alternatively, for example, the control unit **42** may display a three-dimensional position where the object “eighteen tea” on the object image **52a** is detected on the display screen **21a** as the detailed information of the object image **52a**. In this case, the robot recognition information including the three-dimensional position of the object “eighteen tea” on the object image **52a** is stored in the storage unit **45** together with the object image **52a**.

Note that, for example, if the instructing device **21** is a personal computer to which a mouse is connected as the manipulating unit **41**, the user performs a selecting operation (mouseover) by moving a cursor on the object image **52a** on the display screen **21a** using the mouse to select the object image **52a**.

Further, only a predetermined number of object images corresponding to the screen size of the display screen **21a** among the plurality of object images are displayed on the display screen **21a**. Therefore, only an object image having a sufficiently high score, object images having top n-th scores, or an object image which is recognized as either “a target” or “a possible target” are displayed on the display screen **21a**.

Therefore, there is an object image which is not displayed on the display screen **21a**, so that such an object image is preferably displayed on the display screen **21a** in response to the manipulation of the user.

That is, for example, the user performs a scroll operation that rotates a scroll button provided in the mouse to reduce each object image displayed on the display screen **21a** so as to display more object images on the display screen **21a**.

In this case, as the manipulating signal in response to the scroll operation is supplied from the manipulating unit **41**, the control unit **42** reads the robot recognition information stored in the storage unit **45**. Also, the control unit **42** creates each object image reduced in response to the scroll operation based on the read robot recognition information and supplies the object images to the display unit **43** to be displayed on the display screen **21a**.

Further, for example, the user may enlarge each object image displayed on the display screen **21a** in response to the scroll operation and displays fewer object images on the display screen **21a**.

In addition, the display screen **21a**, for example, displays the object image of score x_1 at the center thereof, an object image having a score higher than the score x_1 at the left side, and an object image having a score lower than the score x_1 at the right side.

On the display screen **21a**, an object image having a score x_2 ($<x_1$) lower than the score x_1 may be displayed at the center of the display screen **21a**, an object image basing a score higher than the score x_2 may be displayed at the left side, and an object image having a score lower than the score x_2 may be displayed at the right side.

That is, for example, when the user moves the cursor to a position where the object image having the score x_2 is

displayed and manipulates the manipulating unit **41** so that the position is located at the center position of the display screen **21a**, the robot recognition image allowing the object image having the score x_2 to be displayed at the center of the display screen **21a** is created in the control unit **42** and then displayed on the display screen **21a** of the display unit **43**.

Further, for example, when the user manipulates the manipulating unit **41** so as to locate the position where the object image having the score x_1 is displayed at the center of the display screen **21a**, the display of the display screen **21a** becomes the original display in which the object image having the score x_1 is displayed at the center thereof.

In addition, for example, when the user enlarges a predetermined area among the entire area of the display screen **21a** to be displayed using the manipulating unit **41**, the predetermined area on the display screen **21a** is enlarged to be displayed.

[Description of Operation when Instructing Device **21** Displays Robot Recognition Image]

Next, display processing performed by the instructing device **21** will be described with reference to a flowchart of FIG. **18**.

For example, the display processing starts when the robot recognition information is transmitted from the robot **22**.

In step **S21**, the communicating unit **44** receives the robot recognition information from the robot **22** in accordance with the control of the control unit **42** and supplies the information to the control unit **42**.

In step **S22**, the control unit **42** creates a robot recognition image based on the robot recognition information from the communicating unit **44** and supplies the image to the display unit **43** to be displayed on the display screen **21a**.

Further, the control unit **42** supplies the robot recognition information from the communicating unit **44** to the storage unit **45** to be stored therein.

In step **S23**, the control unit **42** judges whether the selecting operation has been performed by the user in accordance with whether the manipulating signal has been supplied from the manipulating unit **41** in response to the selecting operation by the user.

Further, in step **S23**, if it is judged that the selecting operation has not been performed by the user, the control unit **42** returns the processing to step **S21** and then repeats the same processing.

In addition, in step **S23**, if it is judged that the selecting operation has been performed by the user in accordance with whether the manipulating signal has been supplied from the manipulating unit **41** in response to the selecting operation by the user, the control unit **42** causes the processing to proceed to step **S24**. In this case, for example, it is assumed that the selecting operation for displaying the detailed information of the captured image **52a** shown in FIG. **17** has been performed.

In this case, in step **S24**, the control unit **42** reads the robot recognition information stored in the storage unit **45** and supplies the object images **52b** to **52e** included in the read robot recognition information to the display unit **43** to be displayed on the display screen **21a**. Thereafter, the processing returns to step **S21** and then the same processing is performed. Further, the display processing, for example, ends when the robot recognition information is not transmitted from the robot **22**.

As described above, according to the display processing, the display screen **21a** is displayed as shown in FIGS. **6** to **17** based on the robot recognition information from robot **22** so that it is possible to easily predict the behavior of the robot **22**.

Further, according to the display processing, in step S23, for example, as the selecting operation that selects the object image 52a of FIG. 17 is performed, in step S24, an object captured in the object image 52a is displayed as the object images 52b to 52e as seen from different directions.

Therefore, the user may more precisely figure out an object of the object image displayed on the display screen 21a.

[Configuration Example of Robot 22]

Next, FIG. 19 shows a configuration example of the robot 22.

The robot 22 includes a communicating unit 61, a camera 62, a distance sensor 63, a microphone 64, a speaker 65, a control unit 66, a driving unit 67 and a storage unit 68.

The communicating unit 61 receives instruction information, feedback information, and specified range information from the instructing device 21 and supplies the information to the control unit 66.

The communicating unit 61 transmits the robot recognition information from the control unit 66 to the instructing device 21.

The camera 62 corresponds to “eyes” that sense light and includes, for example, a CCD (charge coupled device) image sensor. The camera 62 captures surroundings of the robot 22 and supplies a captured image obtained by the capturing to the control unit 66.

The distance sensor 63 is a sensor that measures the distance from the robot 22 to the object and measures the distance to the object and supplies the measured distance to the control unit 66.

The microphone 64 corresponds to “ears” that sense sound and collects voice and supplies a voice signal obtained by collecting the voice to the control unit 66.

The speaker 65 corresponds to a “mouth” of the robot 22 and outputs predetermined voice in accordance with the control from the control unit 66.

The control unit 66 controls the communicating unit 61 to the speaker 65, and the driving unit 67. That is, for example, the control unit 66 figures out the surrounding circumstances based on the captured image from the camera 62, the distance from the distance sensor 63, or the voice signal from the microphone 64 and controls the driving unit 67 in accordance with the figured out surrounding circumstances.

Further, the control unit 66 controls the driving unit 67 based on the instruction information from the communicating unit 61 and autonomously performs the behavior instructed by the user. That is, for example, the control unit 66 controls the driving unit 67 to allow the robot 22 to autonomously search, as a target, an object belonging to a category indicated by category information included in the instruction information.

In addition, the control unit 66 detects an object on the captured images based on the captured images from the camera 62 and extracts an object image indicating the detected object. Furthermore, the control unit 66 calculates a score of the detected object based on the captured image from the camera 62.

That is, the control unit 66, for example, reads an identifier of an object which is a target from the storage unit 68 based on the instruction information from the communicating unit 61. Further, the control unit 66 extracts a feature amount indicating a feature of the detected object from the captured images from the camera 62.

Further, the control unit 66 calculates the score of the detected object using the read identifier based on the extracted feature amount. In other words, for example, the control unit 66 may use the identification result (score)

obtained from the identifier as it is as a score of the detected object or calculate a final score in time series manner by integratively judging the identification result obtained from the identifier.

The control unit 66 determines the recognition status of the object based on the calculated score of the object. Further, the determination of the recognition status will be described below with reference to FIG. 20.

Further, the control unit 66 determines an object image to be displayed on the display screen 21a based on the calculated score of the object or the determined recognition status of the object. The method of determining the object image to be displayed on the display screen 21a will be described below with reference to FIG. 21.

The control unit 66, for example, changes an object image which is determined to be displayed on the display screen 21a in accordance with the recognition status of the object (for example, encloses with a rectangle or adds hatched lines) and creates robot recognition information including an object image after the change, a score of the object, and display target information and supplies the information to the communicating unit 61.

Further, the control unit 66 controls the distance sensor 63 to measure the distance to the detected object. As a result, the distance sensor 63 supplies the distance to the object detected by the control unit 66 to the control unit 66.

The control unit 66 detects a three-dimensional position of the camera 62 (robot 22) based on the captured image from the camera 62 or the posture of the camera 62 (position and orientation). Further, the details of a method of detecting the three-dimensional position of the robot 22 are disclosed in Japanese Patent Application Laid-Open No. 2008-304268.

Further, the control unit 66 may use a positioning technology that uses, for example, a GPS (global positioning system) or Wi-Fi to detect the three-dimensional position of the robot 22.

The control unit 66 calculates the three-dimensional position of the sensed object based on the detected three-dimensional position and the distance supplied from the distance sensor 63, associates the position with the captured image in which the object is captured, and supplies the position to the storage unit 68 to be stored therein.

Further, the control unit 66 reads the captured image (for example, the surrounding image 31 or the partial image 35 of FIG. 3) stored in the storage unit 68 and creates a robot recognition image including even the read captured image to be supplied to the communicating unit 61.

The control unit 66 detects the specified area indicating an area specified by the specifying operation of the user based on the specified range information from the communicating unit 61 and the captured image stored in the storage unit 68.

Further, the control unit 66 reads the three-dimensional position associated with the object on the detected specified area from the storage unit 68 and calculates a search range corresponding to the specified area based on the read three-dimensional position.

In addition, the control unit 66 controls the driving unit 67 to drive portions corresponding to hands or feet of the robot 22 to perform an operation of searching a target (object belonging to the category indicated by the category information) within the calculated search range.

The driving unit 67 drives the portions corresponding to “hands” or “feet” of the robot 22 in accordance with the control from the control unit 66 so that the robot 22 autonomously behaves.

The storage unit **68**, for example, holds a control program that is executed by the control unit **66** in advance and further stores (holds) data that is instructed to be written from the control unit **66**.

Further, the storage unit **68** stores an identifier for identifying the object for each object of a plurality of items. The identifier is a function that has the feature amount of the object as an input and outputs the score of the object. In addition, the identifier is generated by being learned in advance and stored.

In addition, the storage unit **68** stores the captured image (the captured image associated with the three-dimensional position of the object on the captured image, for example, the surrounding image **31** or the partial image **35**) from the control unit **66**.

Next, FIG. **20** shows an example of a transition diagram of the recognition status of the object.

In FIG. **20**, as the recognition status that is recognized by the control unit **66**, “not detected (sensed)”, “not sure yet”, “this may be a target”, “this is a target”, and “this is not a target” are shown.

The control unit **66** recognizes the object as any one status of “not sure yet”, “this may be a target”, “this is a target”, and “this is not a target” in accordance with the calculated score of the object.

That is, for example, if the score of the object is equal to or higher than the threshold $th1$, the control unit **66** recognizes that the object “is a target”. If the score of the object is lower than the threshold $th1$ and equal to or higher than a threshold $th2$ ($<th1$), the control unit **66** recognizes that the object “may be a target”.

Further, for example, if the score of the object is lower than the threshold $th2$ and equal to or higher than a threshold $th3$ ($<th2$), the control unit **66** recognizes the status of object as “not sure yet” whether the object is a target. If the score of the object is lower than the threshold $th3$, the control unit **66** recognizes that the object “is not a target”.

In addition, except when the feedback operation is performed by the user, the control unit **66** recognizes that the object “is a target” always through the status that recognizes that this “may be a target”.

Accordingly, on the display screen **21a**, it is possible to prevent an object that is recognized as “not sure yet” whether the object is a target (corresponding to an object image enclosed by a thin-lined rectangle) from being suddenly changed into an object that is recognized “as a target” (corresponding to an object image enclosed by a heavy-lined rectangle).

Therefore, the user may pay attention to only an object that is recognized on the display screen **21a** that “this may be a target” (corresponding to an object image displayed as it is) whether there is an object that does not correspond to a target.

As described above, when the object is recognized “as a target”, the control unit **66** always goes through the status that recognizes that this “may be a target”. This is because, if an object that is recognized on the display screen **21a** as “not sure yet” whether the object is a target is suddenly changed into an object that is recognized “as a target”, this is inconvenient for the user because the user should pay attention to all objects on the display screen **21a**.

Next, FIG. **21** illustrates an example of a determining method by which the control unit **66** determines an object image to be displayed on the display screen **21a** in accordance with the score of the object.

In FIG. **21**, an object **71**, an object **12**, an object **73**, . . . an object **74** are shown from the left side of the drawing in the order of higher scores.

The control unit **66** recognizes the object **71** “as a target” based on the calculated score of the object **71**. Further, the control unit **66** recognizes that the object **72** “may be a target” based on the score of the object **72**.

In addition, the control unit **66** recognizes the status of the object as “not sure yet” whether the object **73** is a target based on the score of the object **73**. Furthermore, the control unit **66** recognizes that the object **74** “is not a target” based on the score of the object **74**.

For example, the control unit **66**, as shown in FIG. **21**, may determine to display the object images corresponding to top N objects having a high score among the plurality of detected objects on the display screen **21a** of the instructing device **21**.

Further, for example, the control unit **66**, as shown in FIG. **21**, may determine to display at least the object images corresponding to objects recognized as “this is a target” or “this may be a target” among the plurality of detected objects on the display screen **21a** of the instructing device **21**.

[Description of Operation when Robot **22** Calculates Score]
Next, with reference to a flowchart of FIG. **22**, the score calculation processing that is performed by the robot **22** will be described.

The score calculation processing, for example, starts when the robot **22** explores the room based on the instruction information from the instructing device **21**.

In step **S41**, the camera **62** captures the surroundings of the robot **22** and supplies the captured image obtained by the capturing to the control unit **66**.

In step **S42**, the control unit **66** tries to detect an object on the captured image based on the captured image from the camera **62**.

Further, when the object is detected from the captured image, the control unit **66** causes the processing to proceed to step **S43** based on the captured image from the camera **62**. In addition, when an object is not detected from the captured image, based on the captured image from the camera **62**, the control unit **66** returns the processing to step **S41** and then performs the same processing.

The control unit **66** judges a target indicating a subject to be processed by the robot **22** based on the instruction information supplied through the communicating unit **61** from the instructing device **21** and reads an identifier for the judged target from the storage unit **68**.

In step **S43**, the control unit **66** calculates a feature amount of the detected object from the captured image from the camera **62**. Next, the control unit **66** calculates a score of the object based on the calculated feature amount using the identifier read from the storage unit **68**.

In step **S44**, the control unit **66** creates robot recognition information including the calculated score or the captured image stored in the storage unit **68** and supplies the information to the communicating unit **61**.

In step **S45**, the communicating unit **61** transmits the robot recognition information from the control unit **61** to the instructing device **21**. The processing returns to step **S41** and then the same processing is performed.

Further, the score calculating processing, for example, ends when the robot **22** finds the target and brings the object to the user.

As described above, according to the score calculation processing, the score of the detected object is calculated and

21

the robot recognition information including the calculated score is transmitted to the instructing device 31.

Therefore, on the display screen 21a of the instructing device 21, the robot recognition image may be displayed as shown in FIGS. 6 to 17 so that the user may easily predict the behavior of the robot 22.

2. Modified Example of First Embodiment

[Another Display Example of Robot Recognition Image]

Referring to FIGS. 6 to 17, the robot recognition images in which the object having a higher score is displayed at farther left side of the display screen 21a have been described, but are not limited thereto.

Next, FIG. 23 illustrates another display example of the robot recognition images.

In FIG. 23, on a upper screen 81 that indicates a screen located at the upper side of the display screen 21a, as a score of an object represented by an object image becomes higher, a robot recognition image that is disposed at farther left of the display screen 21a is displayed. In this case, objects 91, 92, 93, and 94 have high scores in descending order.

Further, a latest captured image obtained by capturing with the camera 62 is displayed on a lower screen 82 that represents a screen located at the upper side of the display screen 21a. As shown in FIG. 23, the object 91 (“apple juice”) and the object 92 (“C soda juice”) displayed on the upper screen 81 are captured in the captured image.

On the display image 21a, the object 91 on the upper screen 81 and the object 91 (“apple juice”) on the lower screen 82 are connected by a dotted line so that the correspondence relationship of the objects 91 displayed on the upper screen 81 and the lower screen 82 may be understood.

The same applies to the object 92. Further, in this case, a latest captured image obtained by capturing with the camera 62 is included in the robot recognition information.

That is, in FIG. 23, the latest captured image obtained by capturing with the camera 62 is displayed on the lower screen 82, unlike the case described with reference to FIGS. 6 to 17.

In FIG. 23, on the upper screen 81, the object images of the objects 91 and 92 are enclosed by a heavy-lined rectangle. Therefore, it is predicted that the robot 22 recognizes the objects 91 and 92 as the target. Further, referring to the lower screen 82 in FIG. 23, it is predicted that the robot 22 exists near the objects 91 and 92.

Therefore, as compared with the case of referring to only the upper screen 81 of FIG. 23, by referring to the upper screen 81 and the lower screen 82 of FIG. 23, the user may easily predict that the robot 22 brings one of the objects 91 and 92 as a target.

Further, in FIG. 23, on the lower screen 82, the latest captured image obtained by capturing with the camera 62 is displayed. However, for example, a captured image obtained by capturing with the camera 62 at a predetermined time may be displayed. In addition, a composite image (image such as a panoramic view) created by composing a plurality of captured images obtained by capturing with the camera 62 may be displayed.

In addition, for example, on the display screen 21a, the captured image obtained by capturing with the camera 62 may be displayed so as to overlap a heavy-lined rectangle (for example, the apple juice on the captured image is enclosed by a heavy-lined rectangle). In this case, in the display screen 21a, an image that is displayed on the upper screen 81 shown in FIG. 23 is not displayed, but only the captured image is displayed.

22

Further, for example, as shown in FIG. 24, instead of the latest captured image obtained by capturing with the camera 62, a space diagram showing a space in the room may be displayed on the lower screen 82 of the display screen 21a. In this case, the robot recognition information includes space information indicating the space diagram of the room. In addition, the space information, for example, is stored in the storage unit 68 of the robot 22 in advance.

In addition, as shown in FIG. 24, in the space diagram displayed on the lower screen 82, a path where the robot 22 moves from now is indicated by a dotted line 101. In addition, in FIG. 24, the object displayed on the upper screen 81 and the position on the space diagram in which the object exists are connected by a dotted line, so that the correspondence relationship can be understood.

Therefore, as compared with the case of referring to only the upper screen 81 of the display screen 21a of FIG. 24, by referring to the upper screen 81 and the lower screen 82 of the display screen 21a of FIG. 24, the user may predict that the robot 22 will return with the object 91 (“apple juice”) as the target.

Further, when the display screen 21a shown in FIGS. 23 and 24 is displayed, it is preferable to preferentially display the object present near the robot 22 (object present in a predetermined range from the position of the robot 22) as the object image.

In addition, for example, on the display screen 21a, the captured image is displaced on the lower screen 82 shown in FIG. 23 and the space diagram is displaced on the upper screen 82 shown in FIG. 24. However, for example, both the captured image and the space diagram may be displayed on the display screen 21a.

In this case, for example, on the display screen 21a, the space diagram including the dotted line 101 indicating the path where the robot 22 moves from now is displayed together with the display shown in FIG. 23.

Next, FIG. 25 illustrates another display example of the robot recognition image.

In FIG. 25, the latest captured image obtained by capturing with the camera 62 of the robot 22 is displayed on the display screen 21a. Objects 111 to 114 detected by the robot 22 are mainly captured in the captured images.

Further, in the objects 111 and 113, the behaviors to be performed with respect to the objects by the robot 22 are displayed by balloons 111a to 113a.

The behavior “discard” is displayed in the balloon 111a, the behavior “bring” is displayed in the balloon 112a, the behavior “bring” is displayed in the balloon 113a, and the behavior “discard” is displayed in a balloon 114a. Further, when the display screen 21a is displayed as shown in FIG. 25, processing information indicating processing (for example, “discard”) of the robot 22 having an object (for example, “bird figurine”) as a target to be processed is included in the robot recognition information from the robot 22.

Further, the sizes of the balloons 111a to 113a, for example, correspond to the scores of the objects with the balloons. In addition, the score may be indicated by the color of the balloons instead of the size of the balloons.

In the first embodiment, the user uses the instructing device 21 to instruct the robot 22 to bring a “tea” as a target. However, the instruction is not limited thereto. The user may instruct, for example, to discard the target in a trash bin.

For example, the user may use the instructing device 21 to instruct to “seize”, “pick up” or “clean up” the target.

For example, FIG. 25 is a display example that is displayed on the display screen 21a of the instructing device 21

when the user uses the instructing device **21** to instruct the robot **22** to bring “juice” and discard a “small object” in the trash bin.

That is, the robot recognition image displayed on the display screen **21a** may be displayed by any displaying method as long as the user may instinctively predict the behavior of the robot **22**.

Further, for example, the user may use the instructing device **21** to select a person as a target other than the “tea” as a target. In this case, the user may use the instructing device **21** to “call” a person as a target.

In this case, for example, the detected person may be displayed on the display screen **21a** together with the name of the person. Further, the name of the person, for example, is stored in the storage unit **68** of the robot **22** in advance in association with an identifier for identifying the person.

Further, if as the name of the detected person, a name of a different person is displayed on the display screen **21a**, the user may use the manipulating unit **41** to change the name into the name of the detected person.

For example, the instructing device **21**, as shown in FIG. **26**, allows the robot recognition image including object images **124** to **124** to be displayed on the display screen **21a** based on the robot recognition information from the robot **22**.

On the display screen **21a** shown in FIG. **26**, it is displayed that the robot **22** recognizes that the object “eighteen tea” corresponding to the object image **121** “may be a target”.

It is also displayed that the robot **22** is “not sure yet” whether the object “C soda juice” corresponding to the object image **122** and the object “potted plant” corresponding to the object image **123** are a target, respectively and the robot recognizes that the object “stuffed animal” corresponding to the object image **124** is “not a target”.

Therefore, the user may predict the behavior of the robot **22** as described below by referring to the display screen **21a** shown in FIG. **26**. That is, for example, the user may predict that the robot **22** eventually recognizes, “as a target”, the object “eighteen tea” that has been recognized by the robot as “a possible target” and will bring the object “eighteen tea”.

In this case, it is considered that the user may wait until the robot **22** brings the object “eighteen tea”.

Further, for example, on the display screen **21a** shown in FIG. **27**, a heavy-lined rectangle indicating that the robot **22** recognizes both the object “ABC tea” corresponding to the object image **141** and the object “S tea” corresponding to the object image **142** as targets is displayed.

In addition, for example, on the display screen **21a** shown in FIG. **27**, a triangle indicating that the robot **22** is going to return with the object “ABC tea” is displayed.

Therefore, the user predicts that the robot **22** is wondering which object “ABC tea” or “S tea” to bring but is going to tentatively return with the object “ABC tea”.

If the object “ABC tea” or the object “S tea” makes no difference to the user, the user does not need to manipulate the instructing device **21** and just waits until the robot **22** brings the object “ABC tea” or the object “S tea”.

Further, for example, on the display screen **21a** of FIG. **27**, since the triangle is not displayed and the object “ABC tea” or the object “S tea” makes no difference to the user, if the user wants to have the object quickly, it is preferable that the user instruct the robot **22** to bring the object “ABC tea”.

Therefore, for example, the instructing device **21**, as shown in FIG. **28**, may indicate the object image **162** corresponding to the object “eighteen tea” that the user

wants to have by the user’s manipulation, among the object images **161** to **165** displayed on the display screen **21a**.

Further, in FIG. **28**, for example, when the triangle is not displayed, as the object image **162** corresponding to the object “eighteen tea” that the user wants to have is indicated by the user’s manipulation, the object image **162** enclosed by the heavy-lined rectangle and indicated by the triangle is displayed on the display screen **21a**.

In addition, for example, if the triangle indicating the object “ABC tea” corresponding to the object image **182** among the object images **181** to **187** is displayed on the display screen **21a** shown in FIG. **29**, it is predicted that the robot **22** returns with the object “ABC tea”.

If the user wants to have the object “S tea”, not the object “ABC tea”, the user manipulates the manipulating unit **41** of the instructing device **21** to instruct the robot **22** to bring the object “S tea” corresponding to the object image **184** instead of the object “ABC tea”.

That is, for example, as shown in FIG. **30**, the user may specify the object image **184** on the display screen **21a** using a pointer (arrow) to instruct the robot **22** to bring the object “S tea” corresponding to the object image **184**.

As a result, on the display screen **21a**, instead of the triangle (FIG. **29**) indicating the object “ABC tea” corresponding to the object image **182**, a triangle (FIG. **30**) indicating the object “S tea” corresponding to the object image **184** is displayed.

3. Second Embodiment

[Example when User Who Watches Display Screen **21a** Instructs Robot **22**]

Next, FIGS. **31** to **38** illustrate an example where the user performs a feedback operation for instructing the robot **22** by manipulating the manipulating unit **41** of the instructing device **21**.

FIG. **31** illustrates an example where the user performs the feedback operation using the manipulating unit **41** of the instructing device **21** by referring to the display screen **21a** of the instructing device **21**.

In FIG. **31**, the object images **201** to **204** displayed on the display screen **21a** are shown. Further, the object images **201** to **202** are enclosed by a rectangle indicating that the robot **22** recognizes the object “as a target”.

Further, the object image **203** is displayed as it is, and the recognition status of the robot **22** for the object “C soda juice” is “not sure yet”. In addition, hatched lines indicating that the recognition status of the robot **22** is “the object is not a target” are added to the object image **204**.

The user may use the manipulating unit **41** of the instructing device **21**, for example, to perform a feedback operation that changes the recognition status of the object “C soda juice” indicated by the object image **203** from “not sure yet” into “this is a target” as shown by an arrow **221**.

Further, for example, the user may use the manipulating unit **41** of the instructing device **21** to perform a feedback operation that changes the recognition status of the object “eighteen tea” indicated by the object image **202** from “this is a target” into “this is not a target” as shown by an arrow **222**.

The control unit **42** creates corresponding feedback information in accordance with the manipulating signal from the manipulating unit **41** corresponding to the feedback operation and supplies the information to the communicating unit **44**. The communicating unit **44** supplies the feedback information from the control unit **42** to the robot **22**.

The robot 22 recalculates the score of the object based on the feedback information from the communicating unit 44 and changes the recognition status of the objects based on the score obtained from the result.

Next, FIG. 32 illustrates an example where the control unit 66 of the robot 22 changes the recognition status of the object in accordance with the feedback information from the instructing device 21.

For example, in the instructing device 21, if the user uses the manipulating unit 41 to perform the feedback operation, the manipulating unit 41 supplies the manipulating signal corresponding to the feedback operation to the control unit 42.

The control unit 42 creates the feedback information based on the manipulating signal from the manipulating unit 41 and supplies the information to the communicating unit 44. The communicating unit 44 transmits the feedback information from the control unit 42 to the robot 22.

In this case, as shown in FIG. 31, for example, it is considered that the user uses the manipulating unit 41 of the instructing device 21 to perform the feedback operation that changes the recognition status of the object "C soda juice" indicated by the object image 203 from "not sure yet" into "this is a target" as shown by an arrow 221.

In this case, in the robot 22, the control unit 66 recalculates the score of the object "C soda juice" based on the feedback information supplied through the communicating unit 61 from the communicating unit 44 of the instructing device 21.

As a result the control unit 66 determines (changes) the recognition status of the object "C soda juice" from "not sure yet" into "this is a target" as shown by an arrow 221₁ is based on a new score obtained by recalculation.

Further, as the feedback operation, if a feedback operation that changes the recognition status of the object from "this may be a target" to "this is a target" performed, the following processing is performed in the control unit 66. That is, for example, the control unit 66 determines the recognition status of the object from "this may be a target" into "this is a target" as shown by an arrow 221₂ based on the feedback information from the communicating unit 61.

In addition, when the feedback operation that changes the recognition status of the object from "this is not a target" into "this is a target" is performed as a feedback operation, the control unit 66 performs the following processing. That is, for example, the control unit 66 determines the recognition status of the object from "this is not a target" into "this is a target" as shown by an arrow 221₃ based on the feedback information from the communicating unit 61.

Further, for example, as shown in FIG. 31, it is considered that the user uses the manipulating unit 41 of the instructing device 21 to perform the feedback operation that changes the recognition status of the object "eighteen tea" indicated by the object image 202 from "this is a target" into "this is not a target" as shown by the arrow 222.

In this case, as shown in FIG. 32, the control unit 66 determines the recognition status of the object "eighteen tea" from "this is a target" into "this is not a target" as shown by the arrow 222 based on the feedback information from the communicating unit 61.

[Example of Feedback Operation]

Next, referring to FIGS. 33 to 38, an example where a user performs the feedback operation by referring to the display screen 21a of the instructing device 21 will be described.

In the instructing device 2, the control unit 42 allows the robot recognition image including, for example, object images 241 to 244 to be displayed on the display screen 21a

of the display unit 43, as shown in FIG. 33, based on the robot recognition information supplied through the communicating unit 44 from the robot 22.

Further, when the robot 22 recognizes an object, "sports drink" indicated by the object image 242 "as a target", the control unit 42 allows the robot recognition image to be displayed on the display screen 21a based on the robot recognition information transmitted through the communicating unit 44 from the robot 22.

As a result, on the display screen 21a, as shown in FIG. 34, a robot recognition image including the object images 241 to 244 is displayed.

On the display screen 21a shown in FIG. 34, it is predicted that the robot 22 recognizes, as a target the object "sports drink" (an object indicated by the object image 242), which is different from the object "eighteen tea" (object indicated by the object image 245) that the user wants to have.

Further, when the robot 22 behaves to bring the object "sports drink" as a target, the control unit 42 allows the robot recognition image to be displayed on the display screen 21a based on the robot recognition information transmitted through the communicating unit 44 from the robot 22.

As a result, the display screen 21a, as shown in FIG. 35, displays the object image 242 added with a triangle indicating that the robot 22 brings the object "sports drink" as a target.

In this case, as shown in FIG. 35, the user uses the manipulating unit 41 of the instructing device 21 to perform the feedback operation indicating that the object "sports drink" is not a target. In this case, the manipulating unit 41 supplies the manipulating signal corresponding to the feedback operation of the user to the control unit 42.

The control unit 42 creates the feedback information based on the manipulating signal from the manipulating unit 41 and supplies the information to the communicating unit 44. The communicating unit 44 transmits the feedback information from the control unit 42 to the robot 22. In this case, for example, the robot 22 (control unit 66) recalculates a score of the object "sports drink" based on the feedback information from the communicating unit 44.

As a result, the score of the object "sports drink" is lower than, for example, the score of the object "eighteen tea" and the robot 22 behaves to bring the object "eighteen tea" as a target. Further, the robot 22 changes the recognition status of the object "sports drink" from "this is a target" to "this is not a target" based on the recalculated score.

In this case, in the instructing device 21, the control unit 42 allows the robot recognition image to be displayed on the display screen 21a based on the robot recognition information transmitted through the communicating unit 44 from the robot 22. Further, the robot recognition information includes at least the score recalculated based on the feedback information in accordance with the feedback operation of the user.

As a result, the display screen 21a, as shown in FIG. 36, displays the object image 245 added with the triangle indicating that the robot brings the object "eighteen tea" as a target.

Further, the user may perform, for example, a feedback operation indicating that the object "eighteen tea" is a target, as shown in FIG. 37, in addition to the feedback operation indicating that the object "sports drink" is not a target.

In this case, for example, the robot 22 (control unit 66) recalculates the score of the object "eighteen tea" based on the feedback information from the communicating unit 44. As a result, the score of the object "eighteen tea" is higher

titan for example the score of the object “sports drink” and the robot **22** behaves to bring the object “eighteen tea” as a target.

In contrast, the control unit **42** of the instructing device **21** allows the robot recognition image to be displayed on the display screen **21a** based on the robot recognition information transmitted through the communicating unit **44** from the robot **22**.

As a result, the display screen **21a**, as shown in FIG. **38**, displays the object image **245** added with the triangle indicating that the robot brings the object “eighteen tea” as a target.

Further, for example, if it is indicated that the object is not a target by the feedback operation, it is considered that the user uses the manipulating unit **41** to designate the object (object image thereof) which is not a target and make the designated object as a target.

In this case, the control unit **42** creates feedback information indicating that the object designated by the user is not a target.

Further, for example, if it is indicated that the object is not a target by the feedback operation, it is considered that the user uses the manipulating unit **41** to designate the object (object image thereof) which is a target and make the object that is not designated an object that is not a target.

In this case, the control unit **42** creates feedback information indicating that the object that is not designated by the user is not a target.

Further, the object may be designated by enclosing, with a frame, the object on the display screen **21a** that is wanted to be designated. In addition, when the manipulating unit **41** includes a mouse, the user moves a cursor or the like to the object on the display screen **21a** to be designated and clicks the left button of the mouse (single clicking or double clicking) to designate the object.

In addition, if the instructing device **21** is a personal computer, and a control key and a shift key are provided as the manipulating unit **41**, the control key and the shift key are used together to click the left button to designate a plurality of objects.

Further, for example, after designating the object, the user may select an option “this is not a target” among the displayed options “this is a target”, “this is not a target”, and the like by clicking a right button of a mouse and perform the feedback operation indicating that the designated object is not a target.

In addition, for example, the user may click the designated object again with the left button of the mouse to cancel the designation of the object. In addition, for example, the user may select an object by clicking the left button to perform a dumping operation that dumps the object outside the frame of the display screen **21a** as the feedback operation indicating that the object is “not a target”.

For example, when the manipulating unit **41** includes an “Enter” key, a pressing operation that presses the “Enter” key while the object is designated may be adopted as the feedback operation indicating that the designated object is a target.

Further, for example, when the manipulating unit **41** includes a “Delete” key, a pressing operation that presses the “Delete” key while the object is designated may be adopted as the feedback operation indicating that the designated object is not a target.

In addition, for example, when the manipulating unit **41** includes a “Tab” key, whenever the user presses the “Tab” key, the focus displayed on the display screen **21a** may be moved.

The same applies to a case where the feedback operation indicating that the designated object is a target is performed. [Regarding Feedback Processing Performed by Instructing Device **21**]

Next, referring to the flowchart of FIG. **39**, the feedback processing performed by the instructing device **21** will be described.

Further, the feedback processing, for example, starts when the power of the instructing device **21** is turned on. In addition, the object image is displayed on the display screen **21a**.

In step **S61**, the control unit **42** judges whether the feedback operation by the user has been performed based on whether the manipulating signal corresponding to the feedback operation has been supplied from the manipulating unit **41**. The control unit **42** repeats the processing of step **S61** until it is judged that the feedback operation by the user has been performed.

In step **S61**, if it is judged that the feedback operation by the user has been performed based on whether the manipulating signal corresponding to the feedback operation has been supplied, the control unit **42** causes the processing to proceed to step **S62**.

In step **S62**, the control unit **42** creates the feedback information based on the feedback operation by the user and supplies the information to the communicating unit **44**.

In step **S63**, the communicating unit **44** transmits the feedback information from the control unit **42** to the robot **22** using the wireless communication or the like and returns the processing to step **S61** and then repeats the same processing. Note that the feedback processing, for example, ends when the power of the instructing device **21** is turned off.

As described above, according to the feedback processing, in accordance with the feedback operation by the user, it is possible to indicate that the object displayed on the display screen **21a** is a target.

Therefore, for example, if the robot **22** recognizes an object that is not a target as a target. It is possible to feed back to the robot **22** that the object is not a target using the instructing device **21**.

[Regarding Score Recalculation that is Performed by Robot **22**]

Next, referring to the flowchart of FIG. **40**, the score recalculation processing performed by the robot **22** will be described.

The score recalculation processing, for example, starts when the power of the robot **22** is turned on.

In step **S81**, the communicating unit **61** repeats the processing of step **S81** until the feedback information from the instructing device **21** is received. In step **S81** when the communicating unit **61** receives the feedback information from the instructing device **21**, the communicating unit **61** supplies the received feedback information to the control unit **66** and causes the processing to proceed to step **S82**.

In step **S82**, the control unit **66** recalculates the score of the object based on the feedback information from the communicating unit **61** and causes the processing to proceed to step **S83**.

In step **S83**, the control unit **66** creates the robot recognition information based on the recalculated score and supplies the information to the communicating unit **61** and causes the processing to proceed to step **S84**.

In step **S84**, the communicating unit **61** transmits the robot recognition information from the control unit **66** to the instructing device **21** using the wireless communication or the like and returns the processing to step **S81** and then

repeats the same processing. Further, the score recalculation processing for example, ends when the power of the robot 22 is turned off.

As described above, according to the score recalculation processing, the score is recalculated based on the feedback information from the instructing device 21 so that the score to which the feedback from the user is reflected may be calculated.

4. Modified Example of Second Embodiment

In the second embodiment, referring to the display screen 21a, the user performs a feedback operation indicating that a predetermined object is a target or is not a target. However, the feedback operation by the user is not limited thereto.

That is, for example, when objects 261 to 263 are displayed, as shown in FIG. 41, on the display screen 21a as one object, the robot 22 recognizes the objects 261 to 263 as one object.

In this case, the user may use the manipulating unit 41 of the instructing device 21, for example, to perform the feedback operation specifying an area on which one object is displayed and allow the robot 22 to recognize the objects 261 to 263 as one object.

Further, if the manipulating unit 44 includes a mouse, the feedback operation specifying an area on which one object is displayed, for example, is performed using the mouse to specify the area on which one object is displayed and select an option "separate" to be displayed by clicking the right button.

Then, the control unit 42 creates the feedback information as the manipulating signal corresponding to the feedback operation is supplied from the manipulating unit 41 and supplies the information to the communicating unit 44. The communicating unit 44 transmits the feedback information from the control unit to the robot 22 by the wireless communication or the like.

In the robot 22, the communicating unit 61 supplies the feedback information from the communicating unit 44 to the control unit 66. The control unit 66 recognizes each of the objects 261 to 263, which have been recognized as one object, as one object 261, 262, or 263 based on the feedback information from the communicating unit 61.

Further, the control unit 66 calculates the scores of the objects 261, 262, and 263 each recognized as one object and creates the robot recognition information based on the calculation result and transmits the information to the instructing device 21 through the communicating unit 61.

In the instructing device 21, the control unit 42 allows the robot recognition image as shown in FIG. 42 to be displayed on the display screen 21a of the display unit 43 based on the robot recognition information transmitted through the communicating unit 44 from the communicating unit 61 of the robot 22.

Further, for example, when something that should be recognized as one object (for example, a set of knife, fork, and spoon that are simultaneously used) is separated and displayed on the display screen 21a as a plurality of objects, the user may use the manipulating unit 41 of the instructing device 21, for example, to perform the feedback operation specifying the area including the plurality of objects separated and displayed so as to allow the robot 22 to recognize the plurality of objects separated and displayed as one object.

In addition, when the manipulating unit 41 includes a mouse, the feedback operation specifying the area including the plurality of objects separated and displayed, for example,

designates the areas on which the objects are displayed using the mouse to select the option "merge" displayed by clicking the right button.

Note that, for example, in the second embodiment, the feedback operation is performed on the object that is displayed on the display screen 21a.

However, for example, when the object on the captured image is not detected by the control unit 66, by the area specifying operation specifying an area including an undetected object on the captured image, the robot 22 may detect (recognize) the undetected object as an object.

As a result, the robot 22, as shown in FIG. 43, detects the unsensed (detected) object and determines the recognition status of the detected object from "undetected" to "not sure yet".

That is, for example, the user may use the manipulating unit 41 of the instructing device 21 to perform the area specifying operation specifying the search range for the robot 22 to search the object to allow the robot 22 to search the object in the search range.

5. Third Embodiment

Next, FIG. 44 illustrates an example where the search range is specified using the captured image.

For example, when the surrounding image 31 as shown in FIG. 44A is included in the robot recognition information as the captured image, the control unit 42 of the instructing device 21 allows the surrounding image 31 to be displayed on the display screen 21a based on the robot recognition information.

In this case, the user may use the manipulating unit 41 of the instructing device 21, as shown in FIG. 44A, to perform the area specifying operation specifying a partial area 281 on the surrounding image 31 displayed on the display screen 21a as an area corresponding to the search range where the target is searched.

As a result, the manipulating unit 41 supplies the manipulating signal corresponding to the area specifying operation of the user to the control unit 42.

The control unit 42 creates the specified range information indicating the partial area 281 specified by the area specifying operation of the user among all the areas on the surrounding image 31 in accordance with the manipulating signal from the manipulating unit 41 and supplies the information to the communicating unit 44. The communicating unit 44 transmits the specified range information from the control unit 42 to the robot 22.

In contrast, the communicating unit 61 of the robot 22 receives the specified range information from the communicating unit 44 of the instructing device 21 and supplies the information to the control unit 66. The control unit 66 detects the partial area 281 on the surrounding image 31 stored in the storage unit 68 based on the specified range information from the communicating unit 61.

Then, the control unit 66 reads a plurality of three-dimensional positions associated with the objects on the partial area 281 from the storage unit 68 and calculates (specifies) the search range for searching the target based on the plurality of read three-dimensional positions.

Further, the calculating method by which the control unit 66 calculates the search range is not limited thereto. That is, for example, even though the three-dimensional positions are not associated with the partial area 281, the control unit 66 may calculate the search range from the partial area 281

or parameters indicating an effective viewing angle, an effective pixel number, a position, and an orientation of the camera 62.

In this case, a first parameter indicating the position and the orientation of the camera 62 at a capturing timing is stored in the storage unit 68 by the control unit 66 together with the capturing timing when the surrounding image 31 is obtained by capturing at the time when the camera 62 captures the image so as to be associated with the surrounding image 31. Further, a second parameter indicating the effective viewing angle and the effective pixel number of the camera 62 is stored in the storage unit 68 in advance.

That is, for example, the control unit 66 reads the first parameter indicating the position and the orientation of the camera 62 at the capturing timing when the surrounding image 31 is obtained by capturing and the second parameter indicating the effective viewing angle and the effective pixel number of the camera 62 from the storage unit 68.

Then, the control unit 66 uses the first and second parameters to specify an area on a real space captured as the partial area 281 in a three-dimensional viewing range corresponding to the partial area 281, that is, at the capturing timing, from the partial area 281 that occupies the surrounding image 31.

Further, as the search range, the area where the robot 22 can move is adopted among the viewing range.

The control unit 66 controls the driving unit 67 to drive the portions corresponding to the hands or feet of the robot 22 and perform the operation for searching the target in the calculated search range.

Further, for example, when the robot recognition information includes the partial image 35 as shown in FIG. 44B, the control unit 42 of the instructing device 21 displays the partial image 35 on the display screen 21a based on the robot recognition information.

In this case, the user may manipulate the manipulating unit 41 of the instructing device 21 to perform the area specifying operation specifying the partial area 282 on the partial image 35 so as to detect the object "apple juice" on the partial image 35 displayed on the display screen 21a.

As a result, the robot 22 performs the operation of searching the target within the search range corresponding to the partial area 282 on the partial image 35. Therefore, the robot 22 may detect the object "apple juice".

Further, as the partial image 35, for example, a captured image obtained when the area specified by the area specifying operation of the user is captured in a nearer range or a partial image of the captured image obtained by capturing in the past may be adopted.

Next, FIG. 45 illustrates an example where the search range is specified using the space diagram of the room.

For example, when the robot recognition information includes a space image 301 as shown in FIG. 45 (image indicating a space diagram of the room), the control unit 42 of the instructing device 21 displays the space image 301 on the display screen 21a based on the robot recognition information. Further, if the storage unit 45 is configured so as to store the space image 301 in advance, the control unit 42 reads the space image 301 from the storage unit 45 and displays the image on the display screen 21a.

In this case, the user may manipulate the manipulating unit 41 of the instructing device 21 to perform the area specifying operation specifying a partial area 321 on the space image 301 displayed on the display screen 21a as the search range.

As a result, the manipulating unit 41 supplies the corresponding manipulating signal to the control unit 42 in accordance with the area specifying operation of the user.

The control unit 42 creates the specified range information indicating the partial area 321 specified by the area specifying operation of the user among all the areas on the space image 301 in accordance with the manipulating signal from the manipulating unit 41 and supplies the information to the communicating unit 44. The communicating unit 44 transmits the specified range information from the control unit 42 to the robot 22. Further, the specified range information may be used as specific information to specify (figure out) the search range for the robot 22 to search the target.

In contrast, the communicating unit 61 of the robot 22 receives the specified range information from the communicating unit 44 of the instructing device 21 and supplies the information to the control unit 66. The control unit 66 detects the partial area 321 on the space image 301 stored in the storage unit 68 based on the specified range information from the communicating unit 61.

Then, the control unit 66 reads a plurality of three-dimensional positions that are associated with sub areas configuring the partial area 321 from the storage unit 68 and calculates the search range based on the plurality of read three-dimensional positions.

The control unit 66 controls the driving unit 67 to drive the portions corresponding to hands or feet of the robot 22 to perform an operation for searching a target within the calculated search range. Further, the control unit 66 performs an operation for searching an object belonging to the category indicated by the category information included in the instruction information as a target within the search range based on the instruction information from the communication unit 61. Further, for example, when the control unit 66 does not receive the instruction information through the communicating unit 61 from the instructing device 21, the control unit 66 allows the robot to autonomously determine the target to perform the operation of searching within the search range.

As a result, the robot 22 performs the operation of searching a target within the search range corresponding to the partial area 321 on the space image 301.

Further, if the space image 301 is displayed on the display screen 21a, when the user uses the manipulating unit 41, for example, to select a partial area 322 among all the areas on the space image 301, a captured image 341 obtained by capturing in the partial area 322 may be displayed on the display screen 21a.

That is, for example, in the instructing device 21, the control unit 42 supplies the robot recognition information that is transmitted through the communicating unit 44 from the robot 22 to the storage unit 45 to be stored therein.

Accordingly, the captured image 341 is stored in the storage unit 45 so as to be associated with the partial area 322 on the space image 301 together with the space image 301 as shown in FIG. 45.

Therefore, when the user selects the partial area 322, the control unit 42 reads the captured image 341 corresponding to the partial area 322 selected by the user from the storage unit 45 and displays the image on the display screen 21a as shown in FIG. 45.

Then, the user may use the manipulating unit 41 to perform the area specifying operation for specifying a partial area 361 on the captured image 341 with respect to the captured image 341 displayed on the display screen 21a in the same manner as shown in FIG. 44B.

As a result, the robot **22** performs an operation for searching the target within the search range corresponding to the partial area **361** on the captured image **341**.

Further, the captured image **341** is transmitted from the robot **22** to the instructing device **21** in a state included in the robot recognition information.

However, the amount of data for the robot recognition information transmitted from the robot **22** to the instructing device **21** is preferably small in order to avoid the convergence of data in the wireless communication or the like.

Accordingly, for example, when the robot **22** transmits the captured image **341** to be included in the robot recognition information, a low quality captured image **341'** as shown in FIG. **46A** which is obtained by reducing the amount of the data of the high quality captured image **341** shown in FIG. **46B** may be transmitted. Further, the captured image **341'** is not used for specifying the area by the user, but used, for example, when the object image of the object "apple juice" is displayed on the display screen **21a**. In addition, preferably, the captured image used for specifying the area by the user is transmitted as a high quality image as it is and displayed on the display screen **21a**.

Since among all the areas on the captured image **341'**, are area **381** where the object (PET bottle of "apple juice") is captured is used as the object image, the captured image **341'** becomes a high quality image and other area than the captured image **341'** (a portion indicated by hatched lines) becomes a low quality image.

That is, for example, the partial area **381** becomes a high resolution area or a color area and other area than the partial area **381** becomes a low resolution area or monochrome area.

[Regarding Area Specifying Processing Performed by Instructing Device **21**]

Next, referring to the flowchart of FIG. **47**, the area specifying processing performed by the instructing device **21** will be described.

In step **S101**, the communicating unit **44** receives the robot recognition information from the robot **22** and supplies the information to the control unit **42**. Further, the robot recognition information, for example, includes the surrounding image **31** as the captured image.

In step **S102**, the control unit **42** supplies the surrounding image **31** included in the robot recognition information from the communicating unit **44** to the display unit **43** to be displayed on the display screen **21a** of the display unit **43**.

In step **S103**, the control unit **42** judges whether the area specifying operation has been performed by the user in accordance with whether the manipulating signal corresponding to the area specifying operation of the user has been supplied from the manipulating unit **41**. Further, the area specifying operation, for example, refers to an operation that specifies a predetermined partial area **281** among all the areas on the surrounding image **31** displayed on the display screen **21a**.

In step **S103**, the control unit **42** repeats the processing of step **S103** until it is judged that the area specifying operation of the user has been performed in accordance with the manipulating signal from the manipulating unit **41**.

In step **S103**, when it is judged that the area specifying operation of the user has been performed, the control unit **42** causes the processing to proceed to step **S104**. In this case, a manipulating signal corresponding to the area specifying operation of the user is supplied from the manipulating unit **41** to the control unit **42**.

in step **S104**, the control unit **42** creates the specified range information indicating the partial area **281** on the

surrounding image **31** specified by the area specifying operation in accordance with the manipulating signal from the manipulating unit **41** and supplies the information to the communicating unit **44**. Further, the specified range information is used as specific information to specify (figure out) the search range for the robot **22** to search the target.

In step **S105**, the communicating unit **44** supplies the specified range information from the control unit **42** to the robot **22** using the wireless communication or the like and allows the robot **22** to search within the search range. By doing as described above, the area specifying processing ends.

As described above, according to the area specifying processing, the search range in which the robot **22** searches the target may be specified by the area specifying operation by the user. Therefore, for example, it is possible to allow the robot **22** to search a target within a range desired by a user.

Specifically, for example, by specifying a range including at least an object that is not detected by the robot **22** as a search range by the area specifying operation by the user, it is possible to allow the robot **22** to search the undetected object.

[Regarding Search Processing Performed by Robot **22**]

Next, referring to the flowchart of FIG. **48**, the search processing performed by the robot **22** will be described.

In step **S121**, the communicating unit **61** receives the specified range information from the communicating unit **44** of the instructing device **21** and supplies the information to the control unit **66**. Step **S121** may be performed along with steps **S122** and **S123** which will be described below. That is, for example, the communicating unit **61** may receive the specified range information from the communicating unit **44** of the instructing device **21** while performing the processing of steps **S122** or **S122**.

In step **S122**, the control unit **66** detects the partial area **281** on the surrounding image **31** stored in the storage unit **68** based on the specified range information from the communicating unit **61**.

Then, the control unit **66** reads a plurality of three-dimensional positions associated with the sub areas constituting the partial area **281** from the storage unit **68** and calculates (specifies) the search range based on the plurality of read three-dimensional positions.

In step **S123**, the control unit **66** drives the driving unit **67** so that the robot **22** can search the target in the calculated search range. Further, the control unit **66**, for example, makes the object belonging to the category indicated by the category information included in the instruction information as a target based on the instruction information from the communicating unit **61**. By doing as described above, the search processing ends.

As described above, in the search processing, the target is searched within the search range specified by the area specifying operation of the user.

Therefore, for example, when a range including at least an object that is not detected by the robot **22** is specified as a search range by the area specifying operation by the user, the robot **22** may detect the undetected object.

Further, the search range is specified by not the object itself, but the area specifying operation of the user because it is difficult to designate the object that is not detected by the robot **22**.

Therefore, the user may allow the robot **22** to search the specified search range to detect the undetected object by specifying the search range including the object that is not detected by the robot **22**.

Further, in step S103 of the area specifying processing, for example, the user specifies a predetermined partial area **281** among all the areas on the surrounding image **31** displayed on the display screen **21a** to specify the search range. However, the method of specifying the search range is not limited thereto.

That is, for example, when the instructing device **21** may recognize a gesture or a posture of a user (hereinafter referred to as gesture and the like) from the captured image obtained by capturing the user, the user may specify the search range by the gesture and the like.

Further, for example, if the instructing device **21** may recognize a voice, the user may specify the search range by the voice. In this case, for example, the user may specify the search range by speaking "kitchen" or "my room" as the search range.

In this case, for example, the user may designate (instruct) a category of the object to be a target by the voice, the gesture and the like. As a result, in the instructing device **21**, instruction information including category information indicating a category designated by the user is created.

In addition, for example, when the robot **22** may recognize the gesture and the like from the captured image obtained by capturing the user, the user may directly specify the search range with respect to the robot **22** by the gesture and the like.

In this case, for example the control unit **66** recognizes the gesture of the user based on the captured image from the camera **62** and obtains (creates) the recognition result as specific information used for specifying the search range. Then, the control unit **66** uses the obtained specific information to specify the search range and controls the driving unit **67** to allow the robot **22** to search a target in the specified search range.

Further, for example, when the robot **22** may recognize a voice, the user may directly specify the search range with respect to the robot **22** by the voice.

In this case, for example, the control unit **66** recognizes the voice of the user based on the voice of the user input from the microphone **64** and obtains (creates) the recognition result as the specific information. Then, the control unit **66** uses the obtained specific information to specify the search range and controls the driving unit **67** to allow the robot **22** to search a target in the specified search range.

In this case, additionally, for example, the user may designate (instructs) the category of the object to be a target directly with respect to the robot **22** by the voice, the gesture and the like.

As a result, in the control unit **66**, instruction information including category information indicating the category specified by the user is created and the robot **22** searches the object belonging to the category indicated by the category information included in the created instruction information as a target.

As the instructing device **21**, for example, a personal computer may be used.

The present technology may have the following configuration.

(1) A control system for an autonomous robot, comprising:
a communications interface that exchanges information with the autonomous robot;

a user interface that displays a scene of a location in which the autonomous robot is positioned, and receives an indication of a user selection of a user selected area within said scene, wherein

said communications interface transmits an indication of said user selected area to said autonomous robot for further processing of said area.

(2) The control system of (1), further comprising:

said autonomous robot having a receiver, wherein said autonomous robot moves to another location in response to said receiver receiving said indication of said user selected area.

(3) The control system of (1), further comprising:

a display, wherein

said scene is displayed on said display and includes a space diagram of a room and the user selected area is a partial area of said room, said space diagram including objects in said room.

(4) The control system of (1), further comprising:

a receiver that receives images from the autonomous robot; and

the autonomous robot, wherein the autonomous robot transmits a second image of the user selected area after transmitting a higher quality image used for selection of the user selected area.

(5) The control system of (1), further comprising:

at least one of a tablet computer and a smartphone that includes said communications interface and a display controller.

(6) The control system of (1), further comprising:

a control unit that generates the indication of said user selected area in response to receiving the indication of the user selection.

(7) The control system of (2), wherein

said autonomous robot is configured to detect a smaller area within said user selected area based on further user input transmitted from the communications interface.

(8) The control system of (7), wherein

said autonomous robot is configured to transmit specified range information that indicates the smaller area that is detected.

(9) The control system of (1), wherein

said scene is a captured image.

(10) The control system of (1), wherein

said scene is a computer generated graphic.

(11) The control system of (12), wherein

the user interface is configured to receive as input a category of a target object within the scene,

the communications interface transmits an indication of said category of target object to the autonomous robot, and the autonomous robot attempts to identify within the scene one or more target objects in said category.

(12) The control system of (11), wherein

the autonomous robot assigns degree information for candidate target objects, the degree information being an indication of a likelihood of correct detection of respective target objects in said category.

(13) The control system of (1), wherein

the user interface is configured to receive voice or gesture input commands.

(14) The control system of (1), further comprising:

a display that displays candidate target objects identified by the autonomous robot and user feedback sent via said communications interface to assist in controlling said autonomous robot.

(15) A display control method for an autonomous robot, comprising:

exchanging information with the autonomous robot via a communications interface;

displaying on a display a scene of a location in which the autonomous robot is positioned;

receiving via a user interface an indication of a user selection of a user selected area within said scene; and

forming with a processing circuit and transmitting an indication of said user selected area to said autonomous robot for further processing of said area.

(16) The method of (15), further comprising:

receiving said indication of said user selected area at said autonomous robot; and

moving said autonomous robot to another location in response to said receiving.

(17). The method of (16), wherein

detecting with said autonomous robot a smaller area within said user selected area in response to receiving further user input.

(18) The control method of (15), wherein

said scene is a captured image.

(19) The control method of (15), wherein

said scene is a computer generated graphic.

(20) A non-transitory computer readable storage medium having instructions stored therein that when executed by a processing circuit perform a display control method for an autonomous robot, comprising:

exchanging information with the autonomous robot via a communications interface;

displaying on a display a scene of a location in which the autonomous robot is positioned;

receiving via a user interface an indication of a user selection of a user selected area within said scene; and

forming with the processing circuit and transmitting an indication of said user selected area to said autonomous robot for further processing of said area.

Note that a series of processing described above may be executed by hardware or software. If the series of processing is executed by the software, the program configuring the software may be installed in a computer embedded in the dedicated hardware or a general purpose computer that may execute various functions by installing various programs from a program recording medium.

[Configuration Example of Computer]

FIG. 49 is a block diagram illustrating a configuration example of hardware of a computer that executes the above-mentioned series of processing by a program.

A CPU (central processing unit) 501 executes various processing in accordance with programs stored in a ROM (read only memory) 502 or a storage unit 508. A program or data that is executed by the CPU 501 is appropriately stored in a RAM (random access memory) 503. The CPU 501, the ROM 502, and the RAM 503 are connected to each other by a bus 504.

An input/output interface 505 is connected to the CPU 501 through the bus 504. An input unit 506 including a keyboard, a mouse, and a microphone and an output unit 507 including a display and a speaker are connected to the input/output interface 505. The CPU 501 executes various processing in accordance with the commands input from the input unit 506. Thereafter, the CPU 501 outputs the processing result to the output unit 507.

The storage unit 508 connected to the input/output interface 505 includes, for example, a hard disk and stores a program or various data to be executed by the CPU 501. A communicating unit 509 communicates with external devices through a network such as the internet or a local area network.

Further, the program may be obtained through the communicating unit 509 and then stored in the storage unit 508.

When a removable medium 511 such as a magnetic disk, an optical disk, a magnetic optical disk or a semiconductor

memory is installed, a drive 510 that is connected to the input/output interface 505 drives the removable medium and obtains the program or data recorded therein. The obtained program or data are transmitted to and stored in the storage unit 508 if necessary.

The recording medium that records (stores) a program that is installed in the computer and is in an executable state by the computer, as shown in FIG. 49, may include the removable medium 511 which is a package medium including a magnetic disk (including a flexible disk), an optical disk (including a CD-ROM (compact disc-read only memory), and DVD (digital versatile disc)), a magnetic optical disk (including MD (mini-disc)) or a semiconductor memory, the ROM 502 that temporally or permanently stores the program or a hard disk that configures the storage unit 508. If necessary, the program may be recorded in the recording medium through the communicating unit 509 which is an interface such as a router or a modem using a wired or wireless communicating medium such as a local area network, the Internet, or digital satellite broadcasting.

Further, in the present specification, the steps that disclose the above-mentioned series of processing may be performed sequentially in accordance with the described order. However, the steps may not be performed sequentially, but may be performed in parallel or individually. With regard to a processor used for executing programs, the processor circuitry may be one or more processors (including CPUs, ASICs, PAL's, etc) working together or separately.

In addition, in the present specification, the system refers to a whole apparatus including a plurality of devices.

Furthermore, the present disclosure is not limited to the first to third embodiments, but various modifications are available without departing from the scope of the present disclosure.

REFERENCE SIGNS LIST

- 1 Robot control system
- 21 Instructing device
- 21a Display screen
- 22 Robot
- 41 Manipulating unit
- 42 Control unit
- 43 Display unit
- 44 Communicating unit
- 45 Storage unit
- 61 Communicating unit
- 62 Camera
- 63 Distance sensor
- 64 Microphone
- 65 Speaker
- 66 Control unit
- 67 Driving unit
- 68 Storage unit

The invention claimed is:

1. A control apparatus for a movable apparatus that includes an imaging unit and a drive unit, the control apparatus comprising:

circuitry configured to:

generate a specific information used for specifying a search range in which the movable apparatus searches for a predetermined object, the search range having been designated as a partial region of a captured image obtained by the imaging unit, wherein the partial region of the captured image including the predetermined object and another object in a region surrounding the predetermined

39

- object, and three-dimensional position information of the another object was previously stored in a storage unit of the movable apparatus; and transmit the specific information to the movable apparatus to read the three-dimensional position information of the another object from the storage unit and to calculate the search range for searching the predetermined object based on the stored three-dimensional position information of the another object.
2. The control apparatus according to claim 1, wherein the circuitry is configured to:
display the captured image; and
generate the specific information according to the search range designated using the displayed captured image.
3. The control apparatus according to claim 1, wherein the circuitry is configured to:
provide an operation signal according to the search range designated by the user; and
generate the specific information based on the operation signal.
4. The control apparatus according to claim 1, wherein the circuitry is configured to:
generate the specific information according to the search range designated using a space diagram of a space where the movable apparatus moves as the search range.
5. The control apparatus according to claim 1, wherein the circuitry is configured to:
acquire the captured image obtained by capturing with the imaging unit.
6. A control method for a movable apparatus that includes an imaging unit and a drive unit, the control method comprising:
generating a specific information used for specifying a search range in which the movable apparatus searches for a predetermined object, the search range having

40

- been designated as a partial region on a captured image obtained by the imaging unit, wherein the partial region of the captured image including the predetermined object and another object in a region surrounding the predetermined object, and three-dimensional position information of the another object was previously stored in a storage unit of the movable apparatus; and transmitting the specific information to the movable apparatus to read the three-dimensional position information of the another object from the storage unit and to calculate the search range for searching the predetermined object based on the stored three-dimensional position information of the another object.
7. The control method according to claim 6, wherein the method further comprises:
displaying the captured image; and
generating the specific information according to the search range designated using the displayed captured image.
8. The control method according to claim 6, wherein the method further comprises:
providing an operation signal according to the search range designated by the user; and
generating the specific information based on the operation signal.
9. The control method according to claim 6, wherein the method further comprises:
generating the specific information according to the search range designated using a space diagram of a space where the movable apparatus moves as the search range.
10. The control method according to claim 6, wherein the method further comprises:
acquiring the captured image obtained by capturing with the imaging unit.

* * * * *