



US010883276B2

(12) **United States Patent**  
**Lingg**

(10) **Patent No.:** **US 10,883,276 B2**  
(45) **Date of Patent:** **Jan. 5, 2021**

(54) **WALL OR FLOOR COVERING ELEMENT**

(71) Applicant: **LI & CO AG**, Müstair (CH)

(72) Inventor: **Edwin Lingg**, Schluderns (IT)

(73) Assignee: **LI & CO AG**, Müstair (CH)

(\*) Notice: Subject to any disclaimer, the term of this patent is extended or adjusted under 35 U.S.C. 154(b) by 0 days.

(21) Appl. No.: **16/137,169**

(22) Filed: **Sep. 20, 2018**

(65) **Prior Publication Data**

US 2019/0085566 A1 Mar. 21, 2019

**Related U.S. Application Data**

(63) Continuation of application No. PCT/IB2017/051651, filed on Mar. 22, 2017.

(30) **Foreign Application Priority Data**

Mar. 23, 2016 (EP) ..... 16161925

(51) **Int. Cl.**

**E04F 13/08** (2006.01)

**E04F 15/10** (2006.01)

(Continued)

(52) **U.S. Cl.**

CPC ..... **E04F 13/0894** (2013.01); **B44C 1/24** (2013.01); **B44C 5/04** (2013.01); **E04F 13/0871** (2013.01);

(Continued)

(58) **Field of Classification Search**

CPC ..... **B44C 1/24**; **B44C 5/04**; **E04F 13/0871**; **E04F 13/0894**; **E04F 13/16**;

(Continued)

(56) **References Cited**

U.S. PATENT DOCUMENTS

4,428,775 A \* 1/1984 Johnson ..... B28B 1/527  
106/719  
2002/0179220 A1\* 12/2002 Cottier ..... B28B 1/522  
156/45

(Continued)

FOREIGN PATENT DOCUMENTS

CN 103 492 175 A 1/2014  
EP 0 843 763 A1 5/1998

(Continued)

OTHER PUBLICATIONS

European Search Report for Application No. 16161925.9 dated Nov. 18, 2016.

(Continued)

*Primary Examiner* — James M Ference

(74) *Attorney, Agent, or Firm* — Jenkins, Wilson, Taylor & Hunt, P.A.

(57) **ABSTRACT**

A covering element for walls, floors, ceilings or the outdoor area, including a carrier plate containing a mineral material, which carrier plate carries a polymer-containing decor layer on its front side, which covering element includes complementary recesses and protrusions extending at its lateral edges, wherein the recesses and protrusions are formed respectively on lateral edges facing away from each other, such that they engage each other when covering elements are situated next to each other, which recesses and protrusions are arranged in the carrier plate.

**15 Claims, 1 Drawing Sheet**

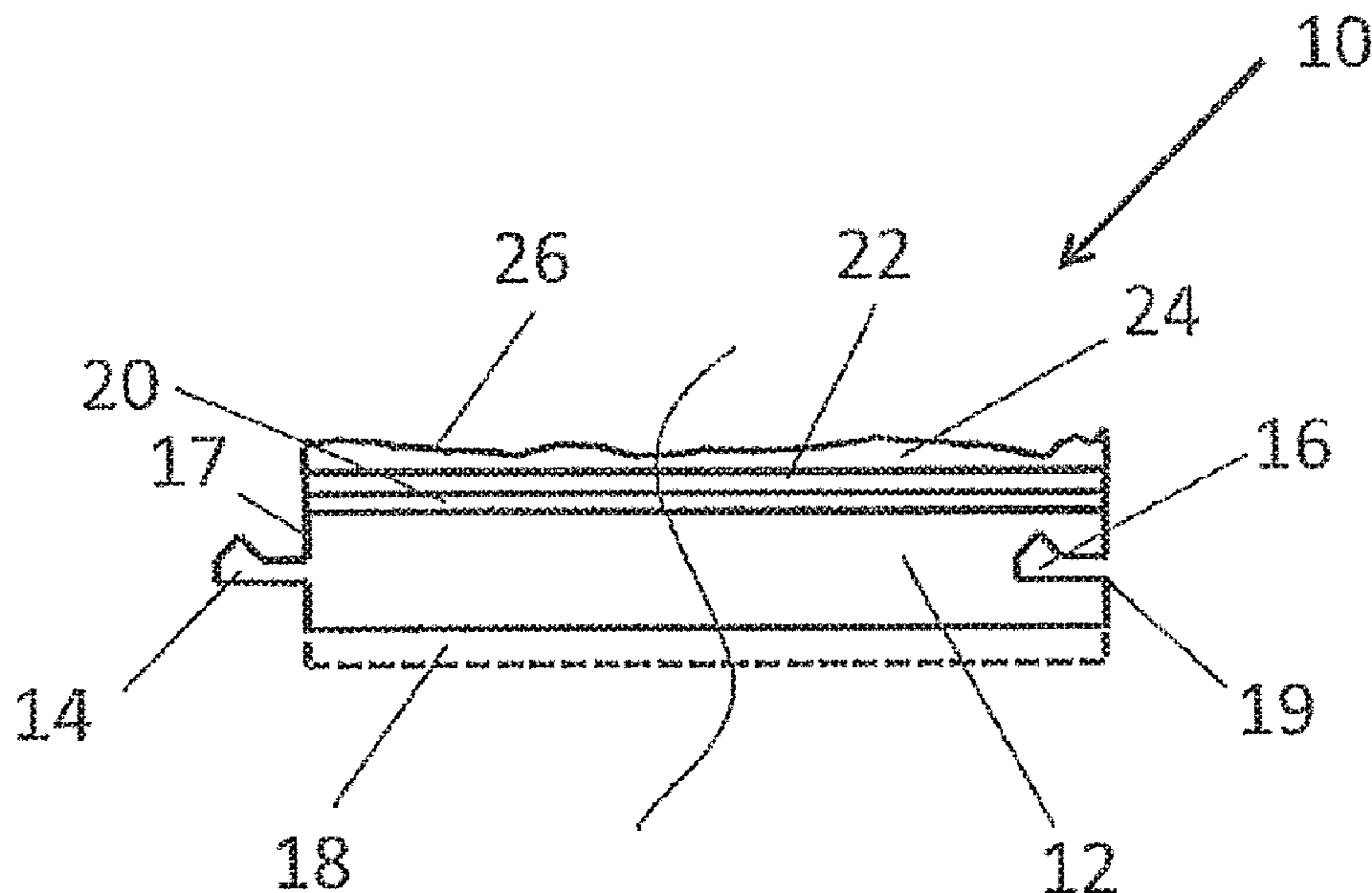

- (51) **Int. Cl.**  
*B44C 5/04* (2006.01)  
*B44C 1/24* (2006.01)  
*E04F 13/16* (2006.01)  
*E04F 15/02* (2006.01)

- (52) **U.S. Cl.**  
 CPC ..... *E04F 13/16* (2013.01); *E04F 15/02005*  
 (2013.01); *E04F 15/02038* (2013.01); *E04F*  
*15/102* (2013.01); *E04F 15/107* (2013.01);  
*E04F 2201/03* (2013.01)

- (58) **Field of Classification Search**  
 CPC ..... *E04F 15/02005*; *E04F 15/02038*; *E04F*  
*15/102*; *E04F 15/107*; *E04F 2201/03*  
 See application file for complete search history.

(56) **References Cited**

U.S. PATENT DOCUMENTS

2005/0064164 A1\* 3/2005 Dubey ..... B28B 5/027  
 428/292.1  
 2005/0070636 A1\* 3/2005 Lee ..... C03C 13/06  
 524/13  
 2007/0110970 A1\* 5/2007 Dubey ..... B28B 1/526  
 428/212  
 2008/0106568 A1\* 5/2008 Albrecht ..... B41J 2/2139  
 347/19  
 2008/0299372 A1\* 12/2008 Stidham ..... B32B 27/12  
 428/220  
 2009/0004378 A1\* 1/2009 Jones ..... B28B 19/0092  
 427/180  
 2009/0162651 A1\* 6/2009 Rios ..... A43B 13/04  
 428/354  
 2010/0009102 A1\* 1/2010 Vermeulen ..... B44B 5/0047  
 428/34.1  
 2011/0047913 A1\* 3/2011 Kim ..... E04C 2/26  
 52/309.13  
 2011/0167744 A1\* 7/2011 Whispell ..... E04F 15/02  
 52/309.1  
 2012/0103722 A1\* 5/2012 Clausi ..... B32B 25/14  
 181/294  
 2012/0276348 A1\* 11/2012 Clausi ..... E04F 15/107  
 428/196  
 2013/0104478 A1\* 5/2013 Meersseman ..... E04F 13/0894  
 52/309.1  
 2013/0177742 A1\* 7/2013 Siebert ..... B44C 5/043  
 428/165  
 2013/0288024 A1\* 10/2013 Clauter ..... B44C 1/24  
 428/201  
 2014/0059970 A1\* 3/2014 Reichinger ..... E04B 1/946  
 52/741.4

2014/0196618 A1\* 7/2014 Pervan ..... B41J 3/407  
 101/32  
 2014/0199532 A1\* 7/2014 Peng ..... B32B 13/04  
 428/215  
 2014/0242342 A1\* 8/2014 Vandevoorde .... E04F 15/02038  
 428/157  
 2014/0256846 A1\* 9/2014 Sevignon ..... C08J 3/215  
 523/156  
 2014/0329064 A1\* 11/2014 Dohring ..... B32B 29/00  
 428/201  
 2015/0017461 A1 1/2015 Lindgren et al.  
 2015/0086773 A1\* 3/2015 Grundy ..... E04C 2/049  
 428/312.4  
 2015/0158241 A1\* 6/2015 Dohring ..... B44C 5/04  
 428/195.1  
 2015/0197943 A1\* 7/2015 Ziegler ..... B32B 37/10  
 428/161  
 2015/0233127 A1\* 8/2015 Dohring ..... E04F 15/02183  
 52/177  
 2015/0251486 A1\* 9/2015 Hannig ..... B41M 3/06  
 428/172  
 2015/0258716 A1\* 9/2015 Hanning ..... B44B 5/026  
 264/400  
 2015/0258845 A1\* 9/2015 Hannig ..... B44C 5/04  
 428/141  
 2015/0298426 A1\* 10/2015 Hannig ..... B32B 38/145  
 428/192  
 2015/0337545 A1\* 11/2015 Granados Pelaez .. E04F 15/107  
 428/58  
 2015/0343739 A1\* 12/2015 Pervan ..... B32B 5/30  
 52/582.1  
 2015/0368912 A1\* 12/2015 Baert ..... E04F 15/02188  
 52/309.15  
 2016/0258152 A1\* 9/2016 Bierschenk ..... C04B 14/304  
 2019/0085566 A1\* 3/2019 Lingg ..... B44C 5/04

FOREIGN PATENT DOCUMENTS

EP 2 202 056 A1 6/2010  
 EP 2 730 429 A1 5/2014  
 WO WO 97/47834 A1 12/1997

OTHER PUBLICATIONS

International Search Report and Written Opinion for Application  
 No. PCT/IB2017/051651 dated Aug. 21, 2017.  
 European Office Action for Application No. 16161925.9 dated Oct.  
 23, 2019.  
 First Office Action for Chinese Application No. 201780018968.9  
 dated Dec. 11, 2019.  
 Chinese Office Action for Application No. 201780018968.9 dated  
 Jun. 28, 2020.

\* cited by examiner

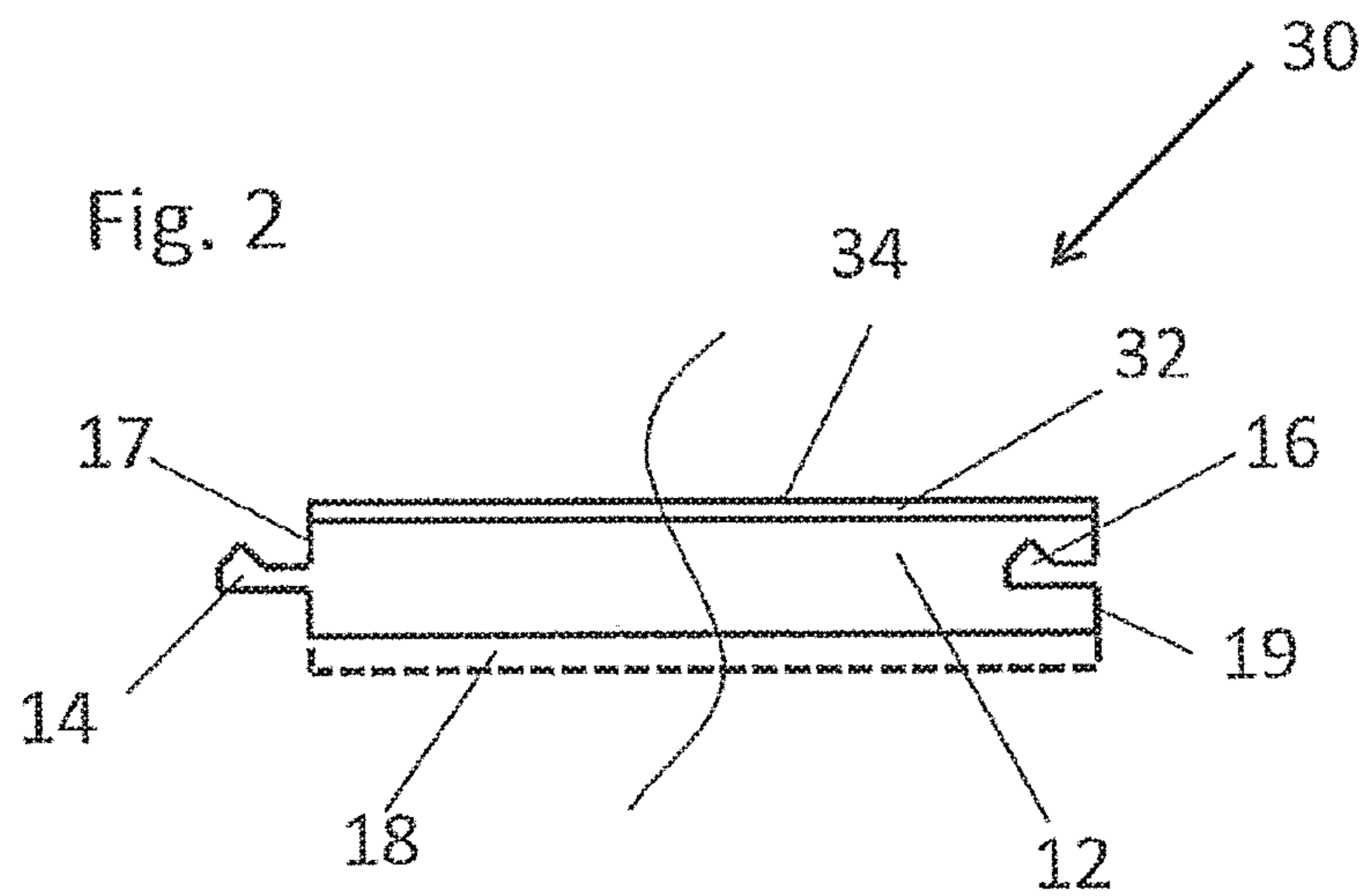
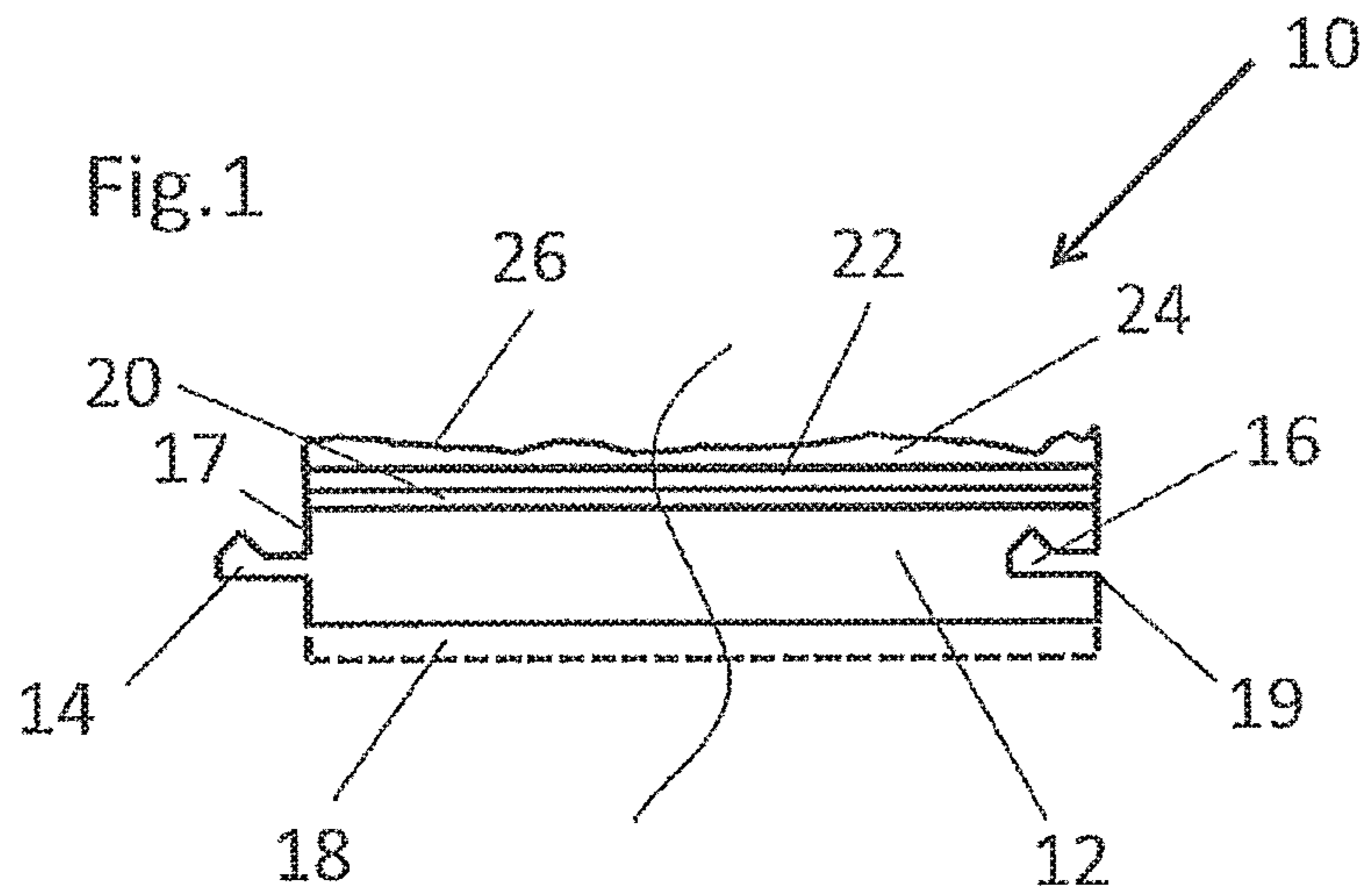

**WALL OR FLOOR COVERING ELEMENT****CROSS-REFERENCE TO RELATED APPLICATION**

This application is a continuation of and claims priority to PCT patent application number PCT/IB2017/051651 filed on Mar. 22, 2017, which claims priority to EP 16161925.9 filed on Mar. 23, 2016 the entire disclosures of which are incorporated by reference herein.

**TECHNICAL FIELD**

The present invention relates to a covering element for ceilings, walls or floors for indoor use as well as for outdoor use.

**BACKGROUND**

Wall or floor covering elements are known, especially for indoor use, which consist of a wood-containing carrier plate or synthetic material, in particular HDF, on which a top layer is provided, wherein the lateral edges of the floor covering element, on the sides facing away from each other, comprise either protrusions or recesses, which, with covering elements arranged next to each other, engage each other in order to enable an easier installation of the covering elements for forming a continuous covering. Such connection often is also called a click connection, as it also enables inexperienced workers to perform a joint-free installation of a covering from a plurality of elements.

**SUMMARY**

It is an object of the present invention to further develop a covering element such that it is individually configurable and insensitive to moisture and temperature changes.

According to the invention, this object is solved by a covering element with the characteristics disclosed herein. Further, the object is solved by a method for manufacturing a covering element according to the disclosure herein. Advantageous developments of the invention are subject of the associated dependent claims and the further description.

According to the invention, the carrier plate is formed as a mineral carrier plate, i.e. it contains at least one mineral, which is pressed together to a plate by a, for example, polymeric adhesion agent. The pressing can be performed cold or possibly under thermal action. Particles, in particular polymer fibers or natural fibers, may serve as adhesion material and stabilizers, which then, in particular under the influence of temperature and pressure, lead to a good bonding (solidification) of the mineral particles, in particular when the latter are fibrous.

According to a particular advantageous embodiment, the carrier plate is formed as a preferably flat, mineral carrier plate on the basis of cement or with a content of cement of between 25 and 85 percent by volume, preferably between 35 and 50 percent by volume. The carrier plate preferably is realized as a fiber cement board. Such carrier plate further also comprises a reinforcement of fibers, for example, between 1 and 40 percent by volume of reinforcement fibers, preferably between 2 and 20 percent by volume. Reinforcement fibers preferably are glass fibers and/or synthetic fibers, as well as polyvinyl- or polyethylene-based fibers. Further, the fiber cement board may comprise fibers which are needed for manufacturing the plate and which do cause no, or almost no, reinforcement of the plate. The content of

these so-called process fibers, for example, fibers of cellulose, jute and/or waste paper, preferably is between 1 and 40 percent by volume, preferably between 2 and 20 percent by volume. Preferably, the plates of this preferred embodiment are manufactured on the basis of the so-called Hatschek method, for example, on the basis of a process as, for example, the process described in U.S. Pat. No. 4,428,775.

The presence of fibers, reinforcement fibers and/or process fibers in the mineral carrier plates applied according to a plurality of preferred embodiments of the invention has important advantages. The reinforcement fibers assign an appropriate locking strength to the recesses and protrusions. The process fibers provide for a suitable adhesion to any kind of decor layers, which are at least partially applied in liquid form, such that the risk of a delamination between decor layer and carrier plate can be reduced.

The advantage of this covering element according to the invention is that it is insensitive to thermal stresses as well as insensitive to moisture.

Preferably, the mineral carrier plate has a strength between 2 and 30 mm, in particular 2 to 20 mm, preferably 3 to 15 mm, depending on whether the covering element is used as a wall covering, ceiling covering or floor covering or where the floor covering will be located, respectively; for example, at a private home or in a factory hall, self-supporting or resting with its complete surface on the underground.

Preferably, the carrier plate consists of or includes mineral elements pressed together with synthetic material or natural fibers, wherein the synthetic fibers preferably have a volume percentage of 1-40%. Such carrier plate has proven very water-resistant as well as thermally resistant and in particular mechanically stable. Moreover, such carrier plate can easily be provided with a decor layer on its surface.

In an advantageous development of the invention, the carrier plate carries an insulating layer on its back side, in particular an elastomer layer, preferably a foamed polymer, in particular elastomer, or a natural product on the basis of cork or wood, in order to provide in this manner a footfall sound insulation and/or thermal insulation to the underlying layer, the wall, respectively. Such covering elements might also be used for thermal protection on exterior façades. Moreover, this insulation layer also serves as a backing layer, such that the plate does not deform due to one-sided coating.

Preferably, the covering element of the invention comprises a barrier layer at the rear side of the carrier plate against the penetration of moisture and/or vapors from the underside. Such barrier layer may consist, for example, of a material layer applied in liquid form or of a prefabricated layer glued to the rear side. The aforementioned insulation layer may also have the function of a barrier layer. Blocking moisture and/or vapors is advantageous in order to reduce or completely avoid possible tendencies of the covering element to warp. Such warping or tendencies to warp lead to tensions in the covering, such in particular in the area of the mutually engaging recesses and protrusions. These tensions may lead to defects.

In an advantageous development of the invention, the decor layer consists of or includes a color pigment-containing basic layer provided on the carrier plate, on which basic layer, at least partially, a color pigment-containing digital printing layer is provided, on which basic layer, digital printing layer, respectively, at least one polymer-containing transparent top layer is provided, which preferably has a structured surface. The basic layer may also be transparent, thus, free from color pigments, or comprise one or more

transparent layers. Due to the digital printing, a decor layer on the basis of a digital print offers a very strong individualization. Thus, for example, different materials, such as wood or leather or stones or fantasy designs can be imitated. The impression caused by the digital print is pronounced by the structured surface, such that with the covering element of the invention arbitrary structures can be simulated very well, such as, for example, wood structures, stone structures and the like.

Preferably, the top layer contains polyurethane or acrylic, which, on the one hand, is very suitable as a wear-resistant top layer and, on the other hand, has the required transparency in order to let the basic layer and/or the digital printing layer show through. Preferably, the top layer contains particles, such as corundum (aluminum oxide) or silicon carbide. These particles result in an increased wear resistance.

Preferably, the top layer contains an electron beam-hardening polymer or a UV-hardening polymer, for example, acrylic-based, wherein the top layer can be deformed, for example, by a structured roller after application on the digital printing layer, basic layer, respectively. In this manner, the surface structure of the covering element can be brought into correspondence with a structure simulated by the digital print, such that the virtual structure, such as, for example, a wood or stone surface, is represented in a very realistic manner.

In an alternative embodiment thereto, the top layer consists of or includes a mixed layer of a polymer matrix material with binding characteristics and a filler, which mixed layer preferably is applied on the carrier plate in liquid condition or in solid form, such as plates or roll form. Due to the liquid application, the mixed layer is bonding very well to the mineral-containing carrier plate, and by the corresponding choice of the filler, such as, for example, leather particles, wood or cork particles, a desired structure can be simulated by the mixed layer as well. Therefore, this embodiment is a cost-effective alternative for the digital print.

Preferably, the surface of the mixed layer is structured, which can be achieved, for example, by a treatment with an embossing roller, in particular as long as the mixed layer is not yet hardened after application, in particular at an elevated temperature between 40 and 100 degrees Centigrade.

According to a further alternative embodiment, the decor layer comprises a foil, whether or not printed, or the decor layer consists of such foil. The foil can be based on paper or synthetic material as well as on PVC (Polyvinyl chloride), PP (Polypropylene), PET (Polyethylene terephthalate), Polyolefin and the like. According to the present alternative embodiment, the foil preferably is glued to the carrier plate. For this purpose, preferably a liquid glue application on the carrier plate is performed. Preferably, with this glue application at least a partial penetration into the carrier plate is achieved.

The recesses and protrusions, forming a tongue/groove connection, of the carrier plate can be formed in the carrier plate prior to applying the decor layer or after applying the decor layer. This is possible in particular because the recesses and protrusions are arranged solely in the carrier plate and not in the decor layer.

Preferably, the protrusions and recesses are manufactured such as described in EP 0843763. In other words, the plate preferably is provided with coupling parts at least on the edges of two mutually opposite sides, wherein the plate comprises one or a combination of two or more of the following characteristics:

the coupling parts are formed in one piece with the carrier plate and cooperate with each other, wherein the coupling parts substantially are realized in the form of a tongue and a groove. It is clear that the groove is an example of a recess according to the invention and the tongue is an example of a protrusion according to the invention;

the characteristic of the preceding passage, wherein said groove is bordered at least by an upper lip, which ends at a vertical plane, and a lower lip, and wherein said tongue has a tongue region which extends from the tip of the tongue inwards up to said vertical plane, when said plates are joined;

the characteristic of the preceding passage, wherein the lower lip is elastically bendable and extends beyond the upper lip, wherein the distance with which the lower lip extends beyond the upper lip is smaller than one time the entire thickness of the carrier plate;

the coupling parts are provided with integrated mechanical locking, which is realized in one piece with the carrier plate, wherein the locking prevents the shifting apart of two covering elements in a direction perpendicular to the respective edge and parallel to the underside of the joined covering elements;

the characteristic of the preceding passage, wherein said integrated mechanical locking comprises, on the one hand, a protrusion, which is situated on the underside of said tongue, wherein said protrusion extends inward at least partially beyond said vertical plane, and wherein said protrusion comprises a contact surface, and, on the other hand, a recess in the lower lip for receiving said protrusion, wherein said recess comprises a contact surface which cooperates with said contact surface of said protrusion such that a tangent line, which is defined by said contact surfaces when the latter are in mutual contact, is inclined in respect to the surface of the covering elements;

the characteristic of the preceding passage, wherein said contact surface of the lower lip is situated at least partially in that region of the lower lip which extends beyond the upper lip;

the characteristic of the preceding passage, wherein said protrusion, said recess and said elastically bendable lower lip are arranged such that they allow a joining or engagement of said covering elements by pushing them laterally towards each other in a substantially planar manner and/or that they allow joining said covering elements by turning;

the coupling parts provide for an engagement free of play according to all directions in the plane situated perpendicular to the edges of the covering elements.

The invention also relates to a method for manufacturing a wall or floor covering element, in which a mineral carrier plate, i.e. a carrier plate comprising at least one mineral material, is coated with a decor layer, wherein prior to or after applying the decor layer recesses and protrusions are created by milling, on lateral edges of the carrier plate which are facing away from each other, which recesses and protrusions form a tongue/groove connection and which, with covering elements situated next to each other, engage each other form-fittingly. Preferably, the tongue and/or groove is realized by a milling process with at least two successive milling actions, by milling cutters positioned at different angles in respect to the respective covering element. For example, during each of the aforementioned milling actions each time substantially the final shape of a flank, either of the tongue or the groove, can be realized.

In an advantageous development of the invention of the method of the invention, the carrier plate is coated with a basic layer, primer, respectively, which preferably contains a color pigment-containing polymer material. On that basic layer, after drying, at least one color pigment-containing digital printing layer is provided in a digital printing process, on which digital printing layer, after drying, hardening, respectively, at least one polymer-containing transparent top layer, for example, polyurethane or acrylic, is provided, wherein the application is performed at an increased temperature in respect to ambient temperature, in particular in a temperature range of 40-100° C., in particular in a temperature range of 60-100° C. Altogether, apart from colored pigments, also white and black pigments are called color pigments.

In the top layer also, preferably at an increased temperature, in particular at 40-100° C., a surface structure is provided, preferably by embossing with at least one structured embossing roller. In this manner, the covering element will create a desired surface impression, for example, the impression of a wood surface or stone surface, very nicely.

In an alternative method, a decor layer is applied, in particular in liquid condition, on the carrier plate, which decor layer is formed by a mixed layer of a hardenable polymer and a filler. The filler may be stone grains, sand, stone dust, wood fibers, wood flour or leather fibers, powdered leather, respectively. In this way, also by this method, which compared to the digital printing method is considerably simpler, a desired surface effect can be achieved, within certain limits. After applying, the mixed layer is hardened, for example, chemically, thermally or optically (UV). In the mixed layer, also linoleum and/or synthetic fibers and/or stone particles can be introduced.

Preferably, the mixed layer is structured on its surface at an increased temperature, in particular at 40-100° C., in particular by an embossing roller, such that the optical impression created by the mixed layer can be pronounced by the surface structure.

In an advantageous development of this method, the mixed layer is hardened to a modulus of elasticity of 0.05-0.5 GPa. The hardened mixed layer thus has an elasticity within the rubber range, wherein, for example, leather surfaces or rubber surfaces can be imitated very well. Herein, hardening the mixed layer can be performed thermally by UV or chemically.

In the digital printing method, the top layer preferably is applied as a hot coating by a hot embossing roller. The transparent top layer may be a single layer or may contain a plurality of layers stacked on top of each other. In particular, this top layer is formed by at least one layer of an UV-hardening lacquer.

Preferably, the transparent top layer contains wear-resistant particles as well as corundum (Aluminum oxide). These hard particles can be brought into the top layer by means of strewing or can be mixed into the actual material of the top layer and provided together with it. It is possible that the top layer is provided in a plurality of layers and that only some of these layers contain the aforementioned particles.

The advantage of the covering element of the invention is that it is waterproof, absolutely dimensionally stable and not combustible and also hardly develops any smoke/fumes. Thus, it solves all problems arising with traditional wood fiberboards, namely moisture sensitivity and high combustibility, as well as the problems arising with synthetic material boards, namely lack of dimensional stability with temperature variations and combustibility, strong smoke and fumes development, respectively. The mineral carrier plate

also is well millable, such that the required recesses and protrusions for forming the tongue/groove connections are easy to mill.

The covering element is suitable as a floor covering, wall covering, ceiling covering or as a façade plate for outdoor use. The mineral carrier plate preferably contains at least one mineral agent known as such, as, for example, ceramics, glass, stone, gypsum, cement, in particular in the form of powder, particles or fibers. The mineral particles or fibers are bonded together by a binding agent, in particular by an adhesion matrix material, in particular natural or synthetic fibers, preferably after thermal pressing or after cold pressing.

As a rule, a covering element according to the invention is rectangular or square, wherein the recesses and protrusions on all four lateral edges are formed such that on two adjacent lateral edges preferably the recesses, or, for example, grooves, are arranged and on the other two adjacent lateral edges the protrusions, or, for example, tongues.

Of course, the mineral carrier plate may be multi-layered. This is the case in particular when the mineral carrier plate relates to a fiber cement board. As mentioned above, such carrier plate can be manufactured according to the Hatschek method. During the Hatschek method, a carrier plate is built from a plurality of sheets of a fiber cement material laminated on top of each other, for example, having the above-described composition for fiber cement boards. A single sheet has a thickness between 0.3 and 1.5 millimeters and preferably between 0.5 and 1 millimeter. With the aim to obtain a carrier plate with a thickness of approximately 6 millimeters, 4 to 20 of such sheets have to be laminated on top of each other, for example, ten layers with a thickness of approximately 0.6 millimeters. Of course, multi-layered fiber cement boards or other mineral carrier plates can also be manufactured according to another method.

As mentioned above, the mineral carrier plate may be multi-layered and preferably comprise 4 to 20 layers. The present invention is applied in particular with covering elements on the basis of such carrier plates. Such carrier plates can have the disadvantage that the binding strength between the various layers is considerably lower than the binding strength internally in each layer. This disadvantage leads to the easier splitting of the mineral carrier plate between the individual layers, for example, when working at or treating the lateral edges. Such treatment can arise, for example, when realizing the recesses and protrusions with milling tools. A risk of splitting also exists when engaging recesses and protrusions. Preferably, at least a part of the decor layer of these covering elements is applied in liquid form. With a liquid application, a certain penetration and reinforcement of the upper layer or upper layers of the carrier plate can be achieved. A penetration and reinforcement of the upper layer is advantageous at the lateral edge comprising the recess. The recess disturbs the balance or equilibrium of the layers, and possibly the layers, which border the recess in upward direction, can deform or bend in upward direction. Also with the engagement of recesses and protrusions forces on these layers may occur which have a similar effect. An at least partial penetration of the liquid material of the decor layer can at least counteract this effect. Preferably, the liquidly applied material penetrates at least so deep into the carrier plate that the material penetrates the upper layer at least partially and also at least partially penetrates into the adjacent layer situated there below. According to this embodiment, also an improved laminating strength between the two upper layers is achieved. In this case, the risk of tearing between the upper layers, or split-

ting, is reduced, for example, when forming the recesses and protrusions with milling tools or with other cutting tools, or when engaging recesses and protrusions.

It is clear that the covering element of the invention preferably shows at least a superficial penetration of the material of the decor layer into the carrier plate. It is also clear that this herein relates to the material of the lower layer or layers of the decor layer. Such penetration is of interest with multi-layered plates, as mentioned above, as well as with single-layered plates. In both cases, an improved adhesion of the decor layer on the carrier plate is achieved. Further, a possibly brittle decor layer, for example, in the case of digital printing, hardens by this anchoring in the carrier plate. In carrier plates containing, in part, fibers, such as process fibers, of cellulose or another, preferably absorbent, material, adherence is further improved. In order to even more improve such penetration, the carrier plate preferably has a porosity of more than 10 percent by volume, preferably between 15 and 40 percent by volume.

Further, it is clear that an at least partial penetration of the material of the decor layer can be achieved with digital printing, with a mixed layer and in those cases that the decor layer comprises a foil glued onto the carrier plate.

With digital printing, the material of a basic layer or of a plurality of basic layers can penetrate into the carrier plate. Preferably, a penetration of the liquid material of the basic layer with a depth of at least 0.1 millimeters is achieved, preferably on the entire surface or on at least 50 percent of the surface. The achieved penetration depth preferably is greater than 15 percent of the thickness of a layer of the carrier plate, in the cases in which a multi-layered carrier plate is used. In order to achieve this and still obtain an excellent adhesion with the further layers of the decor layer, the basic layer preferably is liquidly applied in one or more single layers. A preferred layer construction prior to the digital print on the mineral carrier plate of the invention is as follows:

- at least two layers, preferably at least three layers, of a basic layer, wherein this basic layer is based on a coupling agent, wherein each layer preferably has a wet weight of 5 to 50 g/m<sup>2</sup>. This basic layer can be colored, however, preferably is transparent. With the layers of the coupling agent, a penetration of at least 0.1 millimeters into the carrier plate is achieved and a closed layer is formed on the carrier plate surface to be printed;

- possibly, and preferably in the cases where the coupling agent has not been colored, at least one color pigment-containing layer of a basic color in accordance with the decor to be achieved. With this layer, a uniform basic color is achieved on the surface to be printed;

- one or more color pigment-containing digital printing layers for forming a decor, for example, a decor for wood imitation or stone imitation;

- one or more transparent top layers, preferably polymer-containing top layers, as well as top layers of polyurethane or acrylic.

In a mixed layer, the polymer matrix material can penetrate into the carrier plate. Preferably, a penetration depth of at least 0.1 millimeters is reached, preferably on the entire surface or on at least 50 percent of the surface. The achieved penetration depth preferably is greater than 15 percent of the thickness of a layer of the carrier plate, in those cases in which a multi-layered carrier plate is used. In order to obtain an excellent adhesion, first one or more layers of matrix material can be provided in liquid form on the carrier plate. These layers preferably contain less or no filler material

compared to further layers of the decor layer. Preferably, first layers of the pure matrix material are provided until a closed layer is formed on the carrier plate surface to be decorated. Subsequently then one or more mixed layers can be provided and/or the filler can be provided separately, for example, by strewing.

With the decor layer comprising a foil glued onto the carrier plate, the glue preferably is applied in liquid form and in this manner penetrates at least partially into the carrier plate. Preferably, a penetration depth of at least 0.1 millimeter is achieved, preferably on the entire surface or on at least 50 percent of the surface. The achieved penetration depth preferably is greater than 15 percent of the thickness of a layer of the carrier plate, in the cases in which a multi-layered carrier plate is used. Preferably, by means of the glue application a closed layer is formed on the carrier plate surface to be decorated.

The following terms are used synonymously: basic layer—primer; mineral carrier plate—a carrier plate comprising at least a mineral material; covering element—covering board.

The invention also relates to a covering composed of a plurality of covering elements joined together by their recesses and protrusions formed at the lateral edges.

#### BRIEF DESCRIPTION OF THE DRAWINGS

The invention is described below by way of example by the schematic drawing, wherein:

FIG. 1 shows a cross-section through a first covering element, which comprises a decor layer in the digital printing method; and

FIG. 2 shows a cross-section according to FIG. 2 of a second covering element, which comprises a mineral carrier plate with a mixed layer applied in liquid or solid form.

#### DETAILED DESCRIPTION

FIG. 1 shows a plate-shaped covering element 10, which, with other covering elements 10, can be composed in a planar manner to a floor covering, ceiling covering and/or wall covering, for outdoor use as well. The covering element 10 contains a mineral-containing carrier plate 12, which, at its lateral edges 17, 19 facing away from each other, comprises either protrusions 14 or recesses 16, which, with covering elements situated next to each other, form mating tongue/groove connections. So, in covering elements 10 situated next to each other, the protrusions 14 of one covering element 10 engage the recess 16 of the adjacent covering element 10. Optionally, an insulation layer 18 can be arranged on the rear side, underside, respectively, of the carrier plate 12 for footfall sound insulation and/or thermal insulation. This layer preferably is provided directly on the carrier plate 12 or glued thereon.

On the front side, upper side, respectively, of the carrier plate 12 there is first of all a basic layer 20, which comprises color pigments in order to give the front side, upper side, respectively, of the carrier plate 12 a desired basic color. This basic layer preferably is optional, because basically, with a corresponding choice of the material of the carrier plate 12, the color of the carrier plate can be suitable as a basis for a subsequent digital printing method. A digital print layer 22 is provided on the basic layer 20 in a digital printing method, wherein this digital print layer 22 may be provided not over the entire surface, but only in the areas to be printed. Onto this digital print layer, basic layer 20, respectively, at least one top layer 24 is provided, which in particular

consists of a UV-hardening polyurethane or acrylic. A structure **26** is provided on this top layer **24** by an embossing roller, in particular by the hot coating method, which structure preferably reinforces the impression created by the digital print layer **22**. In this manner, a covering board is created, which reflects the impression of a desired material very well, for example, a wood layer, a leather layer, a stone layer or a cork layer.

The top layer **24** can also be formed by a plurality of layers of an in particular UV-hardening polymer. The application of the top layer **24** and the profiling thereof preferably is performed in the hot coating method by means of a hot roller. The hot coating method is known as such.

FIG. **2** shows an alternative embodiment of a covering element, wherein identical or functionally identical parts in respect to FIG. **1** are provided with the same reference numerals. The floor covering element **30** from FIG. **2** also comprises a carrier plate **12**, which is mineral-containing and comprises protrusions **14** and recesses **16** on lateral edges **17**, **19** facing away from each other. The protrusions and recesses of this tongue/groove system are shown only schematically. In practice, the protrusions **14** and recesses **16** are manufactured as described in document EP 0843763, which document hereby is made subject of the present application. In this context, it should be clarified that a covering element of the invention usually is rectangular, in particular square, and that the recesses and protrusions are formed on four sides, wherein the recesses **16** preferably are arranged on two sides situated next to each other and the protrusions **14** on the other two sides situated next to each other.

On the rear side or underside thereof, the mineral carrier plate **12** optionally comprises an insulation layer **18**, as already known from FIG. **1**. This insulation layer is optional and only necessary if a desired footfall sound insulation and/or thermal insulation are desired. Moreover, this insulation layer, if required, can also be applied as a counterbalancing backing layer. On its upper side, the carrier plate **12** comprises a mixed layer **32** of a polymer and a filler. As a filler, for example, leather, cork, wood, stone, mineral powders, sand are suitable, wherein these materials can be provided in the polymer matrix of the mixed layer either as particles or as fibers. The mixed layer preferably is an elastomer layer, which in particular hardens to a modulus of elasticity of 0.05-0.5 GPa, by which it achieves a rubber-like elasticity. In this manner, for example, an impression of cork, wood or leather can be pronounced very well. Such covering element is very suitable as a wall covering element.

The invention is not limited to the represented exemplary embodiments but can be varied at choice within the scope of protection of the accompanying claims.

#### REFERENCE NUMERAL LIST

- 10** Wall, ceiling or floor covering element (first embodiment)
- 12** mineral carrier plate
- 14** protrusion—tongue of the tongue/groove connection
- 16** recess—groove of the tongue/groove connection
- 17** first lateral edge
- 18** insulation layer
- 19** second lateral edge
- 20** basic layer—primer—coupling agent
- 22** digital printing layer
- 24** transparent top layer
- 30** wall, ceiling or floor covering element (second embodiment)

- 32** mixed layer, in particular applied in liquid form
- 34** optionally structured surface, in particular by embossing roller

The invention claimed is:

**1.** A covering element, the covering element comprising: a carrier plate comprising a mineral material, wherein the carrier plate is formed as a flat mineral carrier plate with a content of cement larger than 35 percent by volume, wherein the carrier plate is multi-layered, wherein the carrier plate carries a polymer-containing decor layer on a front side of the carrier plate, wherein the carrier plate has a thickness between 3 and 15 mm; and

complementary recesses and protrusions respectively on opposing lateral edges of the carrier plate of the covering element, such that in an assembled condition of two or more covering elements the complementary recesses and protrusions engage with each other, wherein an uppermost layer of the carrier plate is reinforced, at least at the opposing lateral edges comprising the recesses, by a portion of a polymer contained in the polymer-containing decor layer that penetrates into the uppermost layer over a depth greater than 0.1 millimeter.

**2.** The covering element of claim **1**, wherein the decor layer comprises at least one, color pigment-containing, base layer on the carrier plate, wherein on the base layer at least one color pigment-containing digital printing layer is arranged, wherein on the digital printing layer at least one polymer-containing transparent top layer is arranged, the polymer-containing transparent top layer having a textured surface.

**3.** The covering element of claim **2**, wherein the polymer containing transparent top layer contains PUR or acrylic.

**4.** The covering element of claim **2**, wherein the polymer-containing transparent top layer contains a UV-hardening polymer, the polymer-containing top layer, after being applied, being deformed on the outer surface by a structured roller.

**5.** The covering element of claim **1**, wherein the decor layer comprises a mixed layer of a polymer binding material and a filler, wherein the mixed layer is on the carrier plate in liquid condition.

**6.** The covering element of claim **5**, wherein the filler comprises cork or leather particles.

**7.** The covering element of claim **5**, wherein a surface of the mixed layer is structured.

**8.** The covering element of claim **1**, wherein the carrier plate comprises mineral elements pressed together with synthetic or natural fibers, wherein the synthetic fibers have a percentage by volume of 1 to 40%.

**9.** The covering element of claim **1**, wherein the carrier plate is a multi-layered fiber cement board.

**10.** The covering element of claim **1**, wherein the carrier plate has an insulating layer that is an elastomer layer on a rear side of the carrier plate.

**11.** A method for manufacturing a covering element, the method comprising:

providing a carrier plate comprising a mineral material, wherein the carrier plate is formed as a flat mineral carrier plate with a content of cement larger than 35 percent by volume, wherein the carrier plate has a thickness between 3 and 15 mm; coating the carrier plate with a decor layer; and



**11**

prior to or after providing the decor layer, on opposite lateral edges of the carrier plate, milling respectively recesses and protrusions for a tongue/groove connection,

wherein the decor layer is a polymer-containing decor layer, wherein at least a part of the polymer-containing decor layer is applied in liquid form, and wherein a polymer contained in the polymer-containing decor layer penetrates into an uppermost layer of the carrier plate over a depth greater than 0.1 millimeter, at least

at the opposite lateral edges comprising the recesses.

**12.** The method of claim **11**, wherein the carrier plate is coated with at least one base layer, which comprises a color pigment-containing, polymer material, wherein onto the base layer, after drying, at least partially at least one color pigment-containing digital printing layer is provided by digital printing, wherein onto the color pigment-containing digital printing layer after drying, hardening, respectively, at

**12**

least one polymer-containing transparent top layer is provided with a temperature above an ambient temperature, wherein on the top layer, at an increased temperature above the ambient temperature, a surface structure is provided by embossing with at least one structured embossing roller.

**13.** The method of claim **12**, wherein the top layer is provided at a temperature of 40 to 100 degrees Centigrade and treatment of a surface thereof is performed with a structured roller at a temperature of 40 to 100 degrees Centigrade.

**14.** The method of claim **11**, wherein on the carrier plate a hardening decor layer is provided in liquid form and is hardened, wherein the decor layer is a mixed layer of a hardenable polymer, in particular elastomer, and at least one filler.

**15.** The method of claim **14**, wherein the mixed layer is hardened to a modulus of elasticity of 0.03 to 0.5 GPa.

\* \* \* \* \*