



US010872632B2

(12) **United States Patent**  
**Kato**

(10) **Patent No.:** **US 10,872,632 B2**  
(45) **Date of Patent:** **Dec. 22, 2020**

(54) **DISK DEVICE WITH BASE AND COVER**

(71) Applicants: **Kabushiki Kaisha Toshiba**, Tokyo (JP); **Toshiba Electronic Devices & Storage Corporation**, Tokyo (JP)

(72) Inventor: **Yasuhiko Kato**, Setagaya Tokyo (JP)

(73) Assignees: **Kabushiki Kaisha Toshiba**, Tokyo (JP); **Toshiba Electronic Devices & Storage Corporation**, Tokyo (JP)

(\*) Notice: Subject to any disclaimer, the term of this patent is extended or adjusted under 35 U.S.C. 154(b) by 0 days.

(21) Appl. No.: **16/855,286**

(22) Filed: **Apr. 22, 2020**

(65) **Prior Publication Data**  
US 2020/0251137 A1 Aug. 6, 2020

**Related U.S. Application Data**

(63) Continuation of application No. 16/284,308, filed on Feb. 25, 2019, now Pat. No. 10,672,424.

(30) **Foreign Application Priority Data**

Sep. 10, 2018 (JP) ..... 2018-168876

(51) **Int. Cl.**  
**G11B 5/60** (2006.01)  
**G11B 33/14** (2006.01)  
**G11B 25/04** (2006.01)  
**G11B 33/02** (2006.01)

(Continued)

(52) **U.S. Cl.**  
CPC ..... **G11B 5/6005** (2013.01); **G11B 5/012** (2013.01); **G11B 25/043** (2013.01); **G11B 33/022** (2013.01); **G11B 33/148** (2013.01);

**G11B 33/1486** (2013.01); **F16C 2370/12** (2013.01); **G11B 2005/0005** (2013.01); **G11B 2220/2508** (2013.01)

(58) **Field of Classification Search**  
CPC ... **G11B 5/6005**; **G11B 33/022**; **G11B 33/148**; **G11B 33/1486**; **G11B 25/043**; **G11B 5/012**; **G11B 2220/2508**; **G11B 2005/0005**; **F16C 2370/12**  
See application file for complete search history.

(56) **References Cited**

U.S. PATENT DOCUMENTS

6,721,128 B1 4/2004 Koizumi et al.  
7,218,473 B2 5/2007 Bennett et al.  
7,876,528 B2 1/2011 Uefune et al.  
(Continued)

FOREIGN PATENT DOCUMENTS

JP 2007-280555 A 10/2007  
JP 2007-328880 A 12/2007

*Primary Examiner* — Brian E Miller

(74) *Attorney, Agent, or Firm* — White & Case LLP

(57) **ABSTRACT**

According to one embodiment, a disk device includes a disk-shaped recording medium, a base accommodating the recording medium, the base including a bottom wall, a sidewall on a peripheral portion of the bottom wall, and a rib on a part of an upper surface of the sidewall, a first cover on a part of the upper surface of the sidewall, and a second cover on a first surface of the rib and above the first cover. The rib includes a first region with a first width, a second region with a second width less than the first width, and the first surface with a fixed width around an entire circumference of the rib. The first region and the second region are located corresponding to a side portion of the recording medium.

**7 Claims, 6 Drawing Sheets**

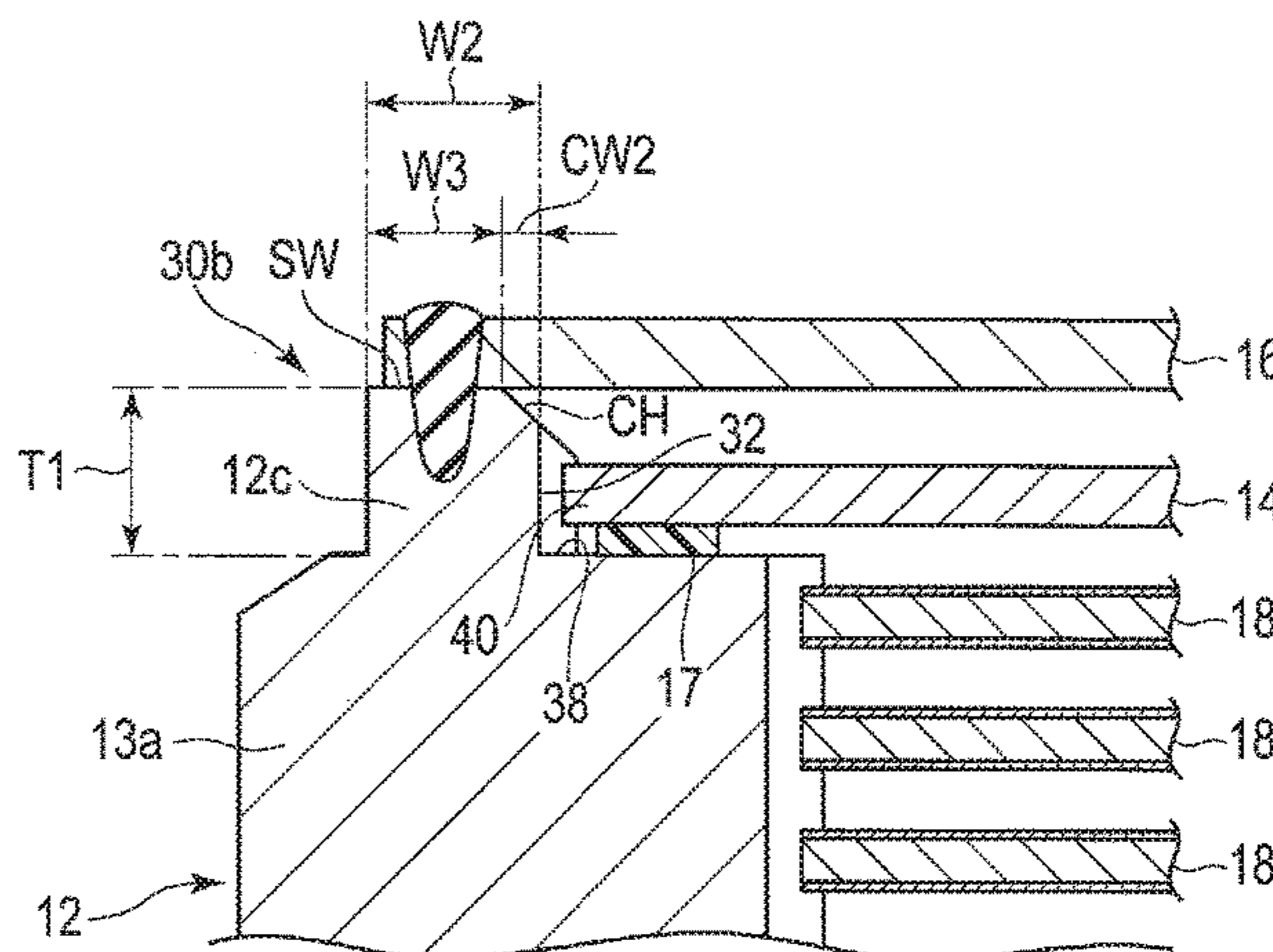
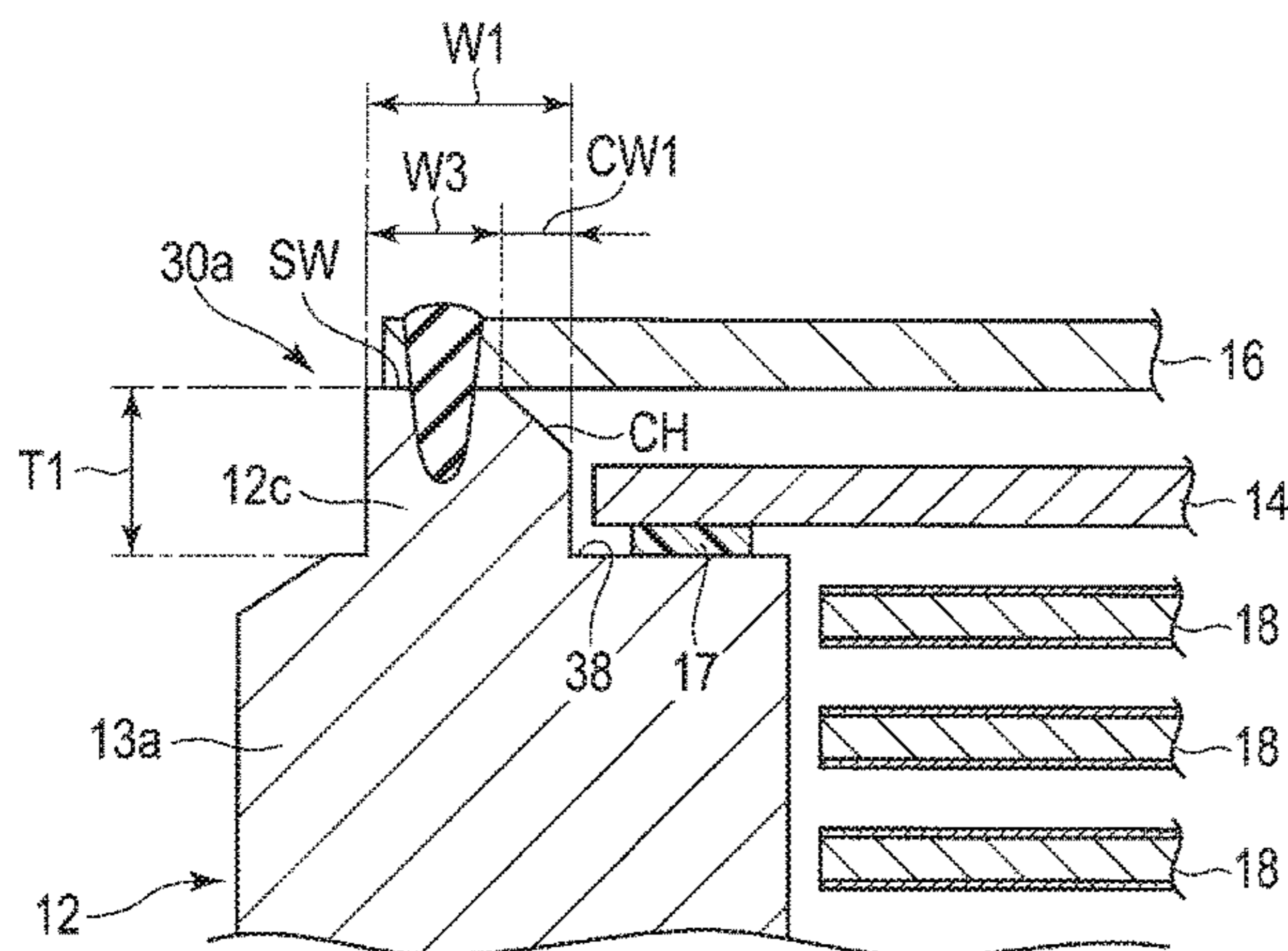

- (51) **Int. Cl.**  
*G11B 5/012* (2006.01)  
*G11B 5/00* (2006.01)

(56) **References Cited**

U.S. PATENT DOCUMENTS

7,957,092	B2	6/2011	Ichikawa et al.	
8,279,552	B2	10/2012	Stipe	
8,659,849	B2	2/2014	Hayakawa et al.	
8,854,766	B1	10/2014	Gustafson et al.	
9,779,779	B1	10/2017	Okamoto et al.	
9,818,454	B1	11/2017	Albrecht et al.	
9,852,777	B2	12/2017	Albrecht	
10,672,424	B2*	6/2020	Kato .....	G11B 5/012
2007/0008697	A1	1/2007	Choi et al.	
2009/0241322	A1	10/2009	Uefune et al.	
2013/0222947	A1	8/2013	Sugii et al.	
2019/0074038	A1*	3/2019	Aoki .....	G11B 33/148

\* cited by examiner

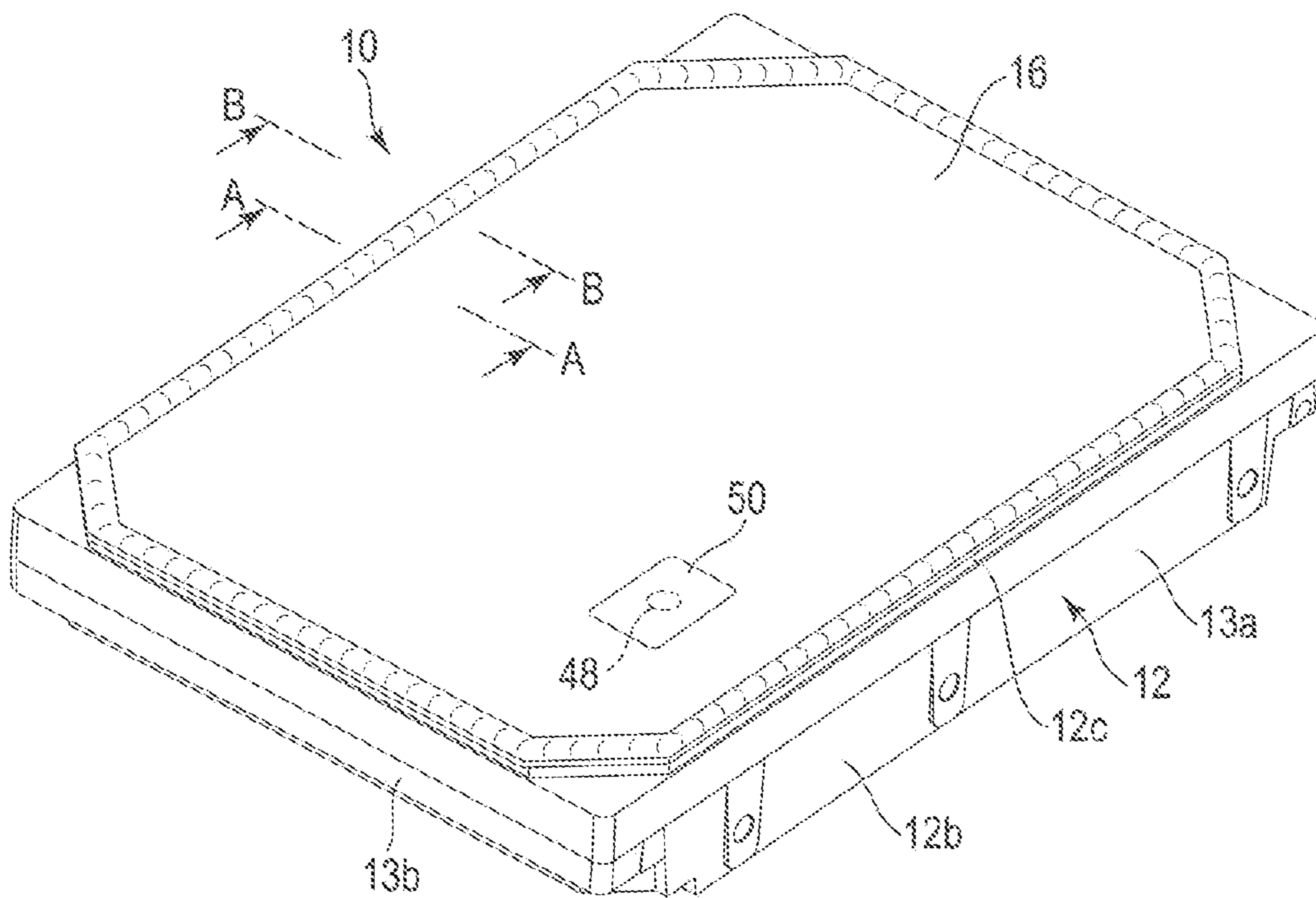

FIG. 1

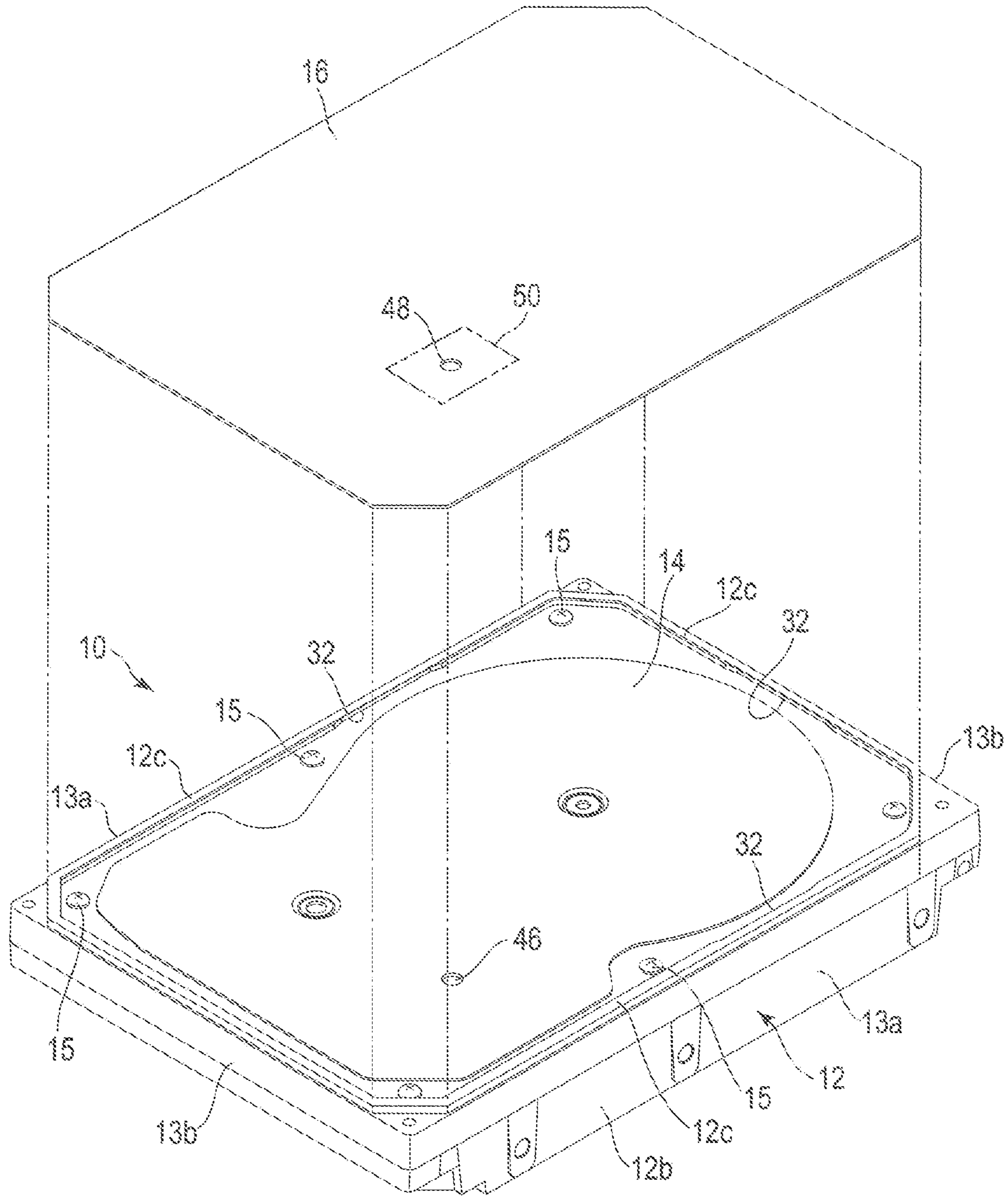

FIG. 2

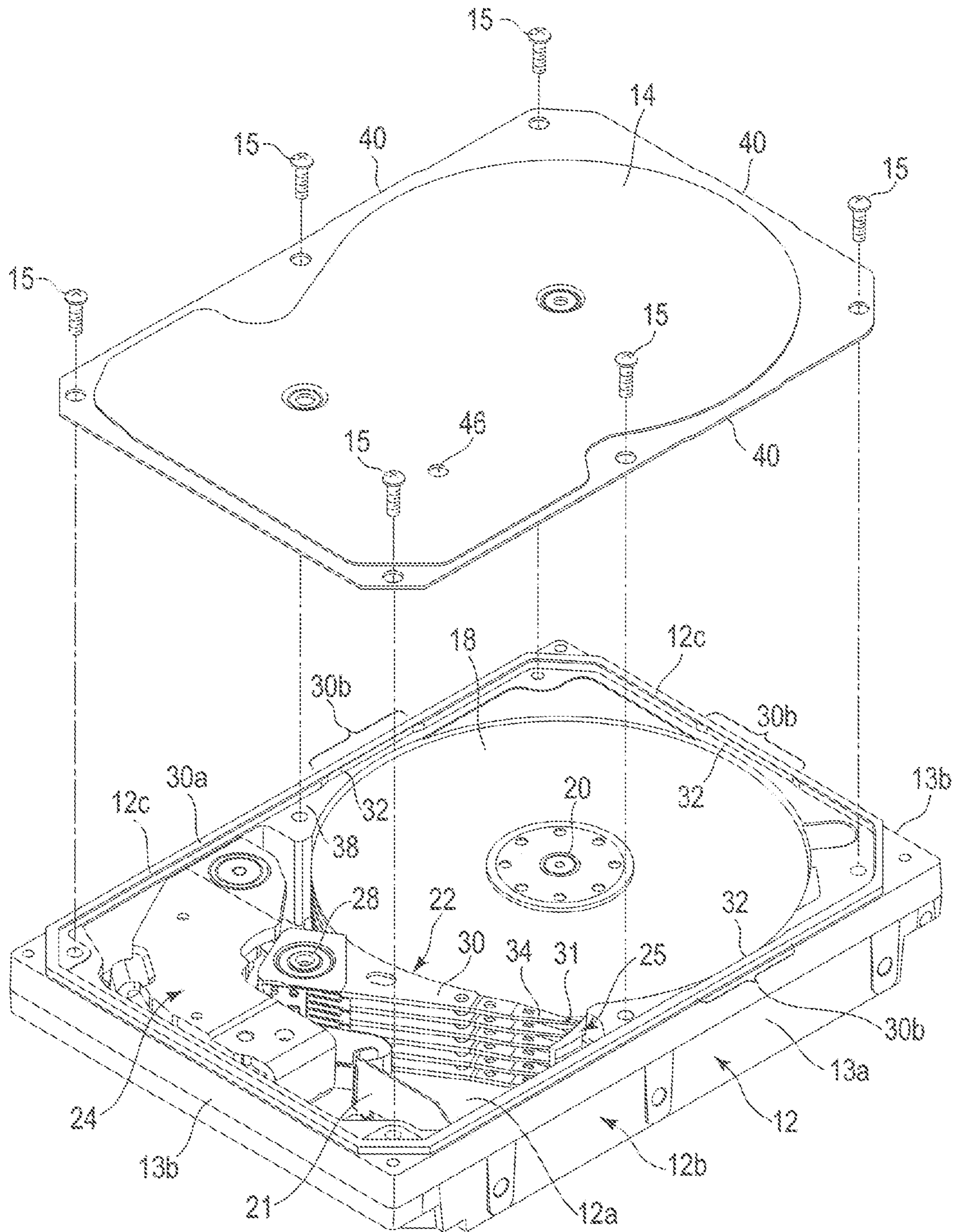

FIG. 3

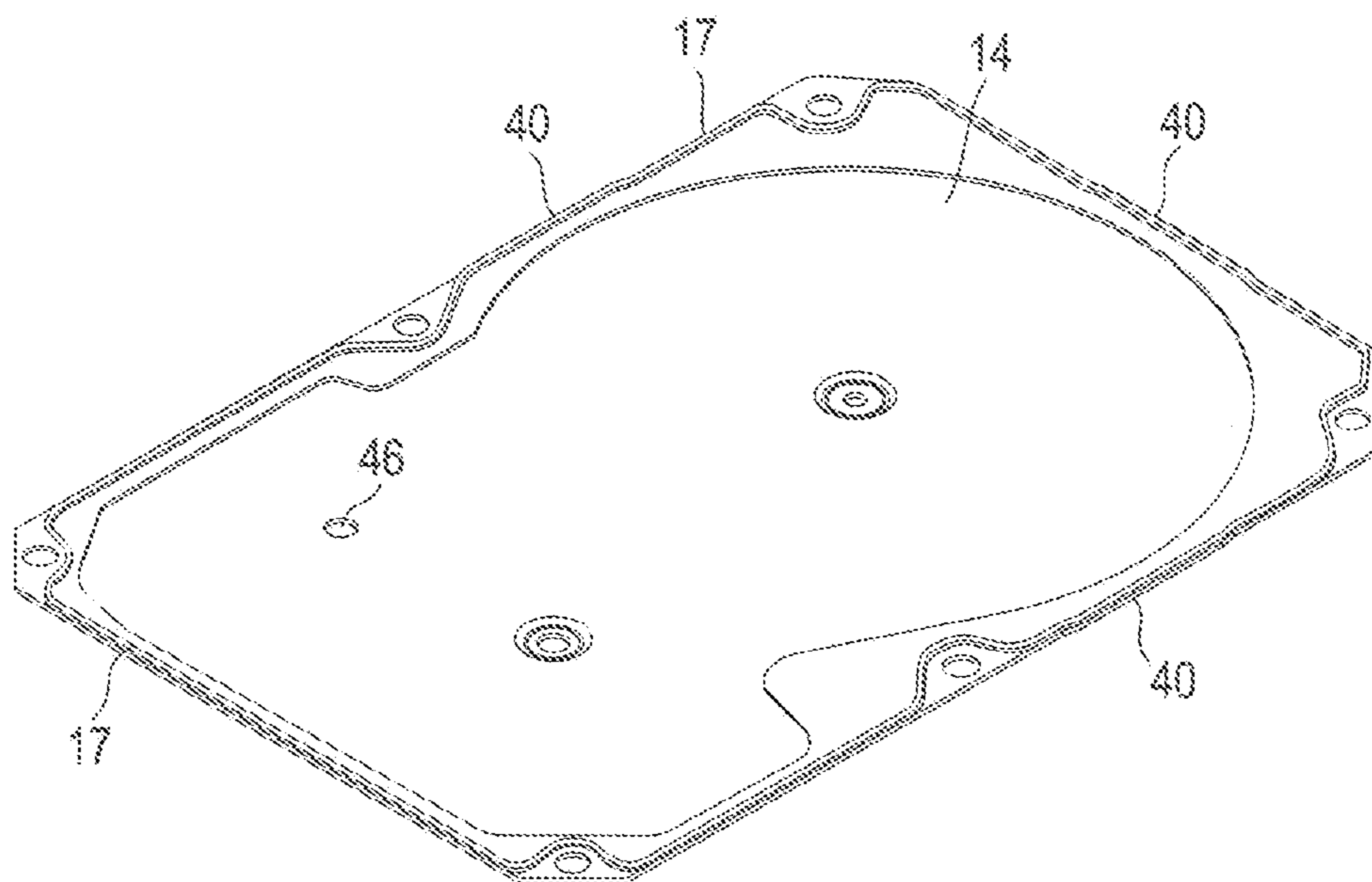

FIG. 4

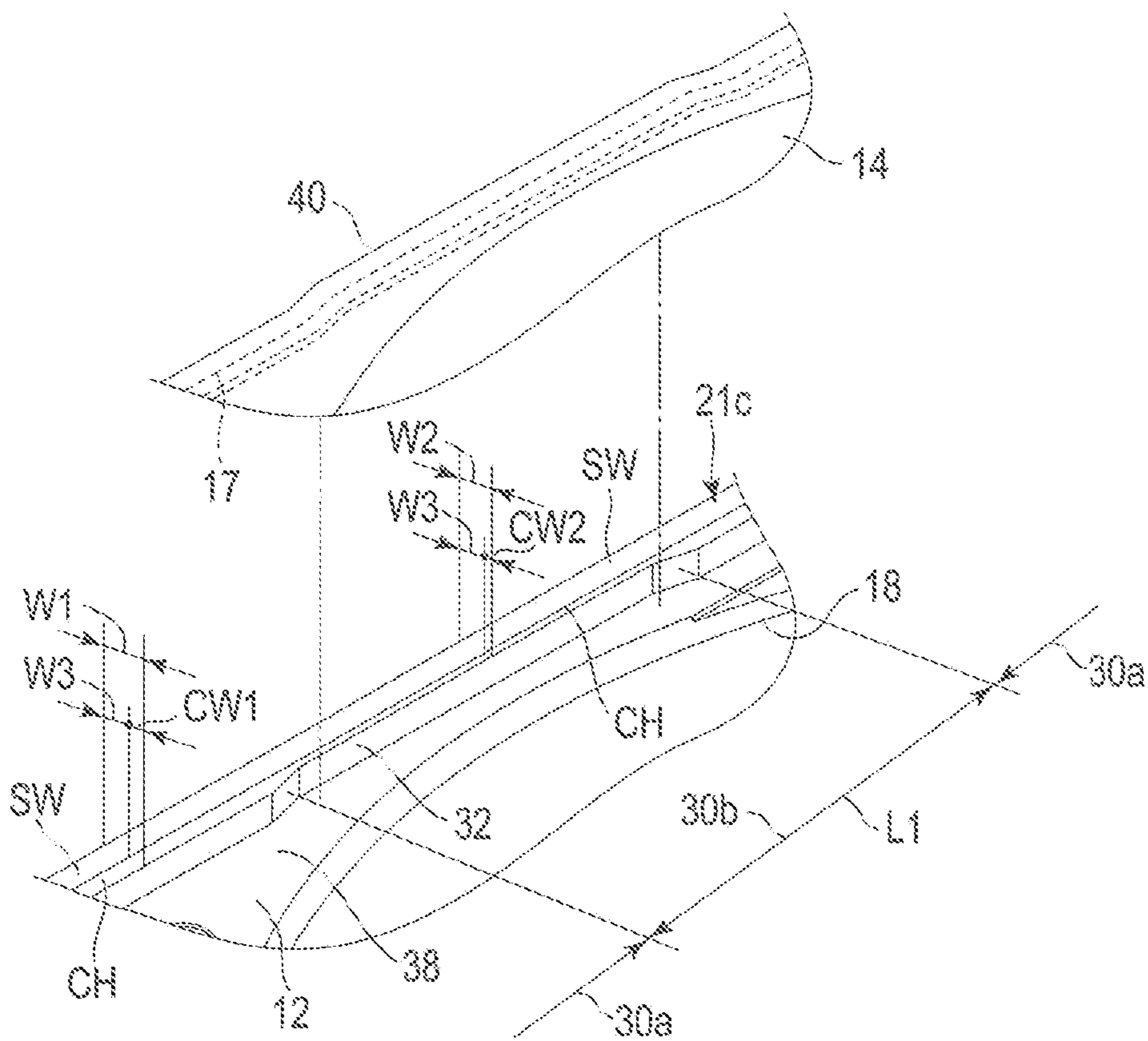

FIG. 5

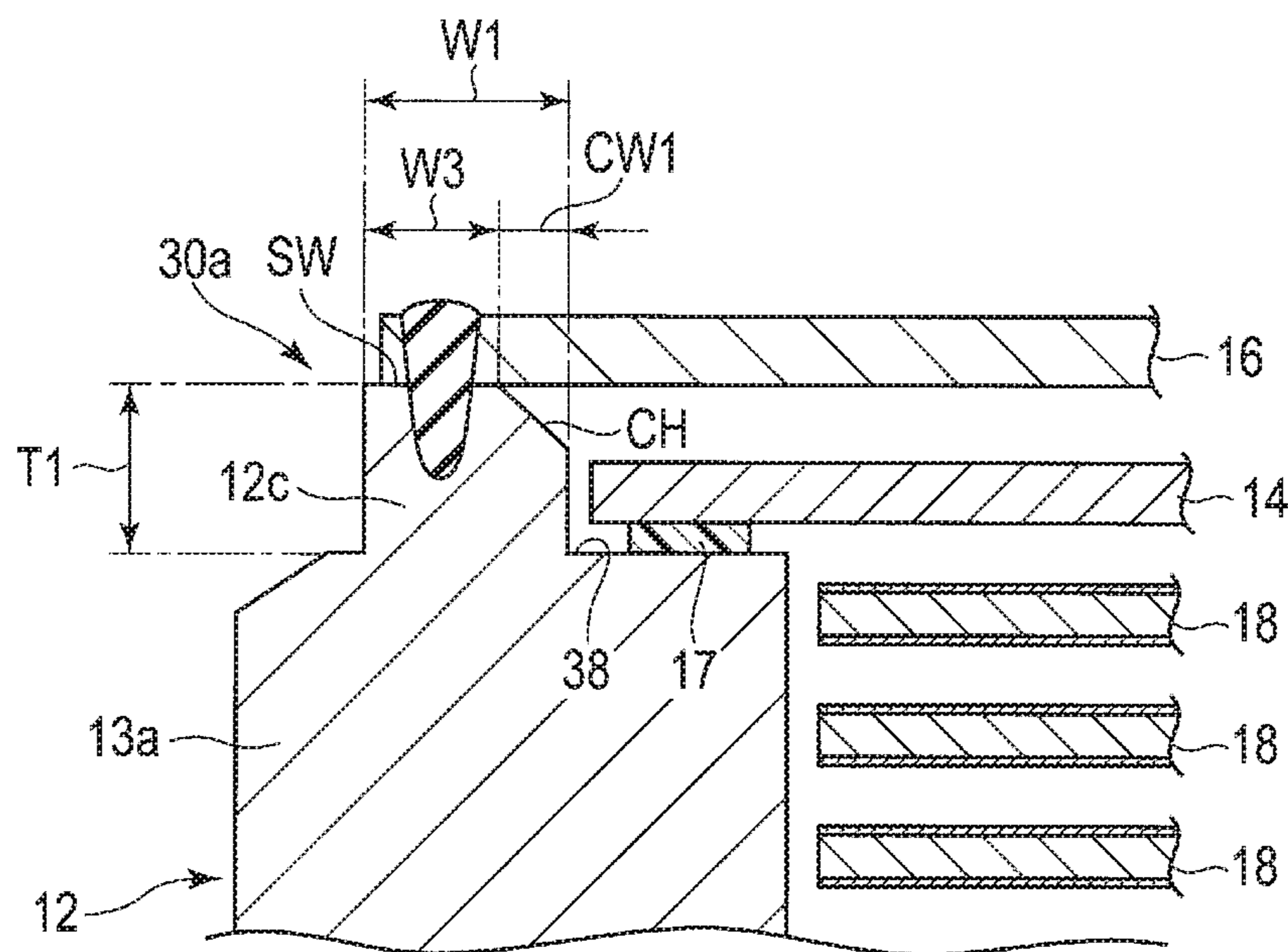

FIG. 6

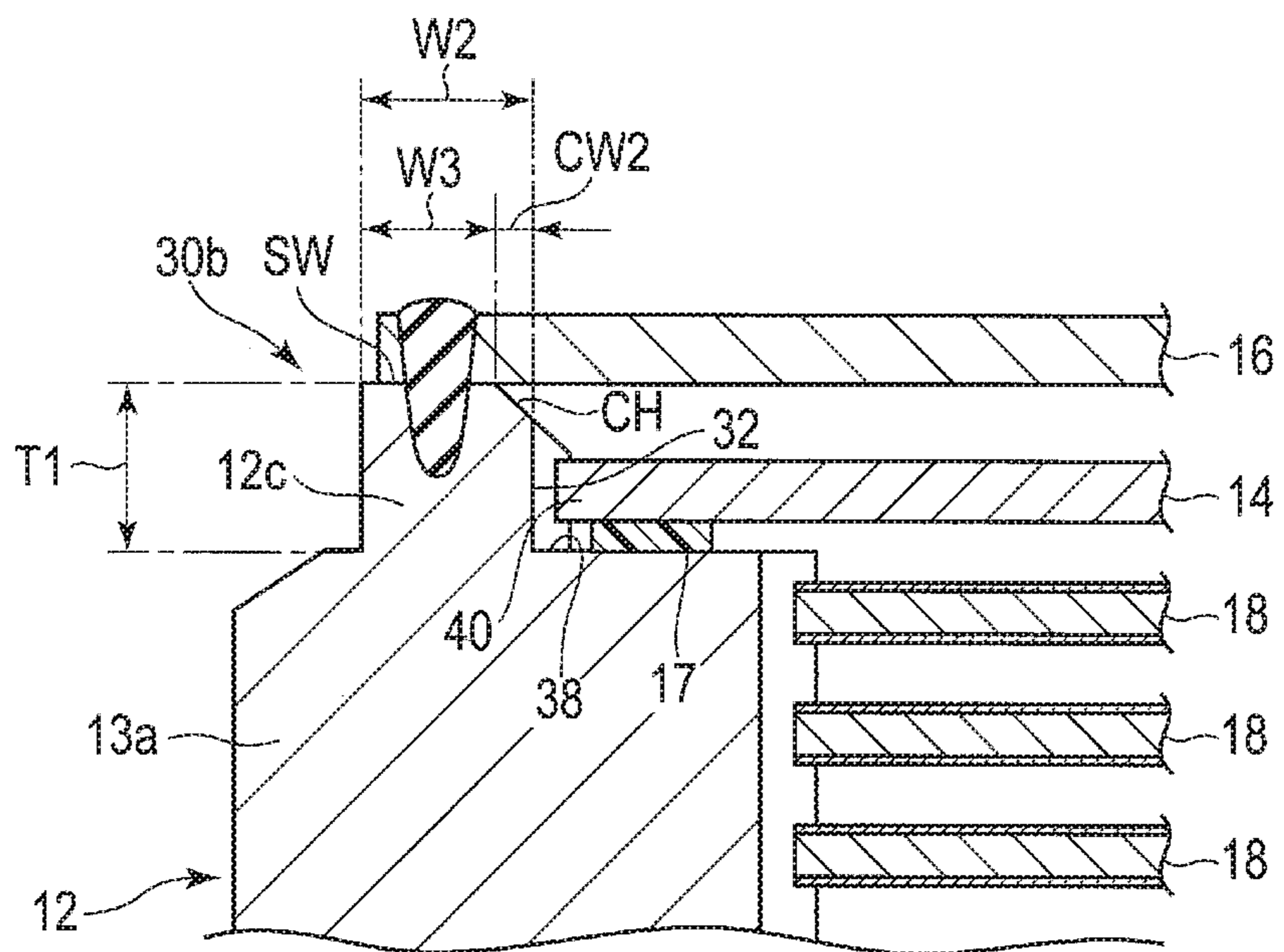

FIG. 7

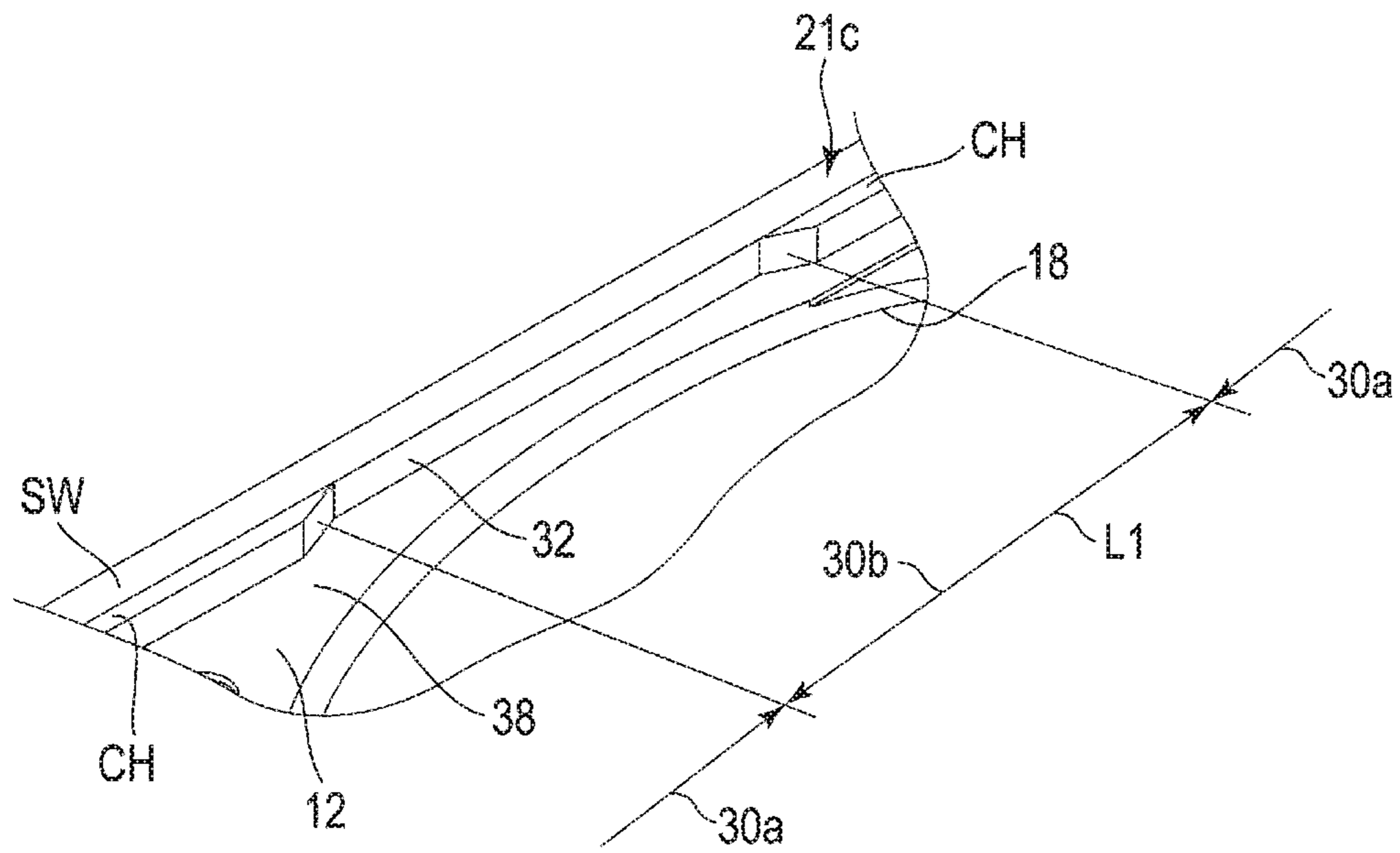

FIG. 8

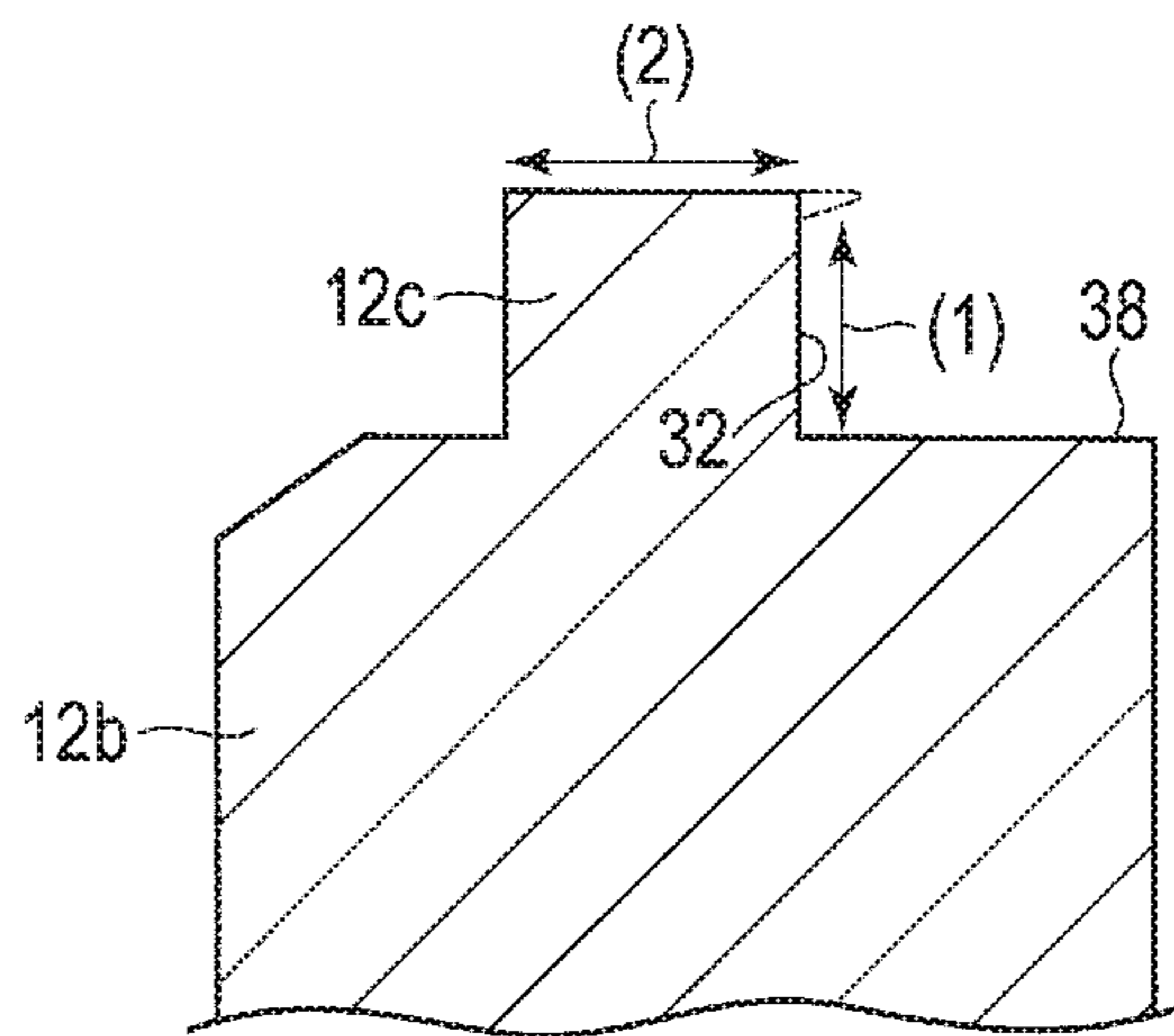

FIG. 9



**DISK DEVICE WITH BASE AND COVER**CROSS-REFERENCE TO RELATED  
APPLICATIONS

This application is a continuation of application Ser. No. 16/284,308 filed Feb. 25, 2019 and is based upon and claims the benefit of priority from Japanese Patent Application No. 2018-168876, filed Sep. 10, 2018, the entire contents of which are incorporated herein by reference.

## FIELD

Embodiments described herein relate generally to a disk device.

## BACKGROUND

As a disk device, a magnetic disk drive comprises a housing including a base and a top cover, and the housing accommodates therein a rotatable magnetic disk, an actuator supporting a magnetic head and the like. As a technique of improving the performance of the disk drive, a method of reducing rotational resistances of the magnetic disk and the magnetic head, by sealing low-density gas in the housing, has been proposed.

In such a magnetic disk drive, the top cover is jointed to the base of the housing by welding to form an enclosed housing and increase the airtightness of the housing. The welding is carried out on along an entire outer circumference of the top cover. Here, in order to obtain high airtightness, it is necessary to maintain a stable welding quality all around the circumference. On the other hand, in the case where the outer diameter of the magnetic disk, the wall portion of the base needs to be formed thinner, which may accordingly decrease the area of the welded portion and degrade the welding quality.

## BRIEF DESCRIPTION OF THE DRAWINGS

FIG. 1 is a perspective view showing a hard disk drive (HDD) according to a first embodiment.

FIG. 2 is an exploded perspective view of the HDD while an outer cover thereof being removed.

FIG. 3 is an exploded perspective view of the HDD while an inner cover thereof being removed.

FIG. 4 is a perspective view showing an inner side of the inner cover.

FIG. 5 is an exploded and enlarged perspective view of a recess portion of a base and a protruding portion of the inner cover.

FIG. 6 is a cross sectional view of the HDD taken along line A-A of FIG. 1.

FIG. 7 is a cross sectional view of the HDD taken along line B-B of FIG. 1.

FIG. 8 is an enlarged perspective view showing a side wall portion of an HDD according to a second embodiment.

FIG. 9 is a cross-sectional view schematically showing a side wall portion, to illustrate a step of processing the side wall portion.

## DETAILED DESCRIPTION

Various embodiments will be described hereinafter with reference to the accompanying drawings. In general, according to one embodiment, a disk device comprises a disk-shaped recording medium; a base accommodating the

recording medium, the base comprising a bottom wall, a sidewall on a peripheral portion of the bottom wall, and a rib on a part of an upper surface of the sidewall, the rib comprising a first region with a first width, a second region with a second width less than the first width, and a first surface with a fixed width around an entire circumference of the rib, the first region and the second region being located corresponding to a side portion of the recording medium; a first cover provided on a part of the upper surface of the sidewall; and a second cover provided on the first surface of the rib and provided above the first cover.

## First Embodiment

As a disk device, a hard disk drive (HDD) according to the first embodiment will be described in detail. FIG. 1 is a perspective view showing the appearance of the HDD according to the embodiment, and FIGS. 2 and 3 are exploded perspective views of the HDD when decomposed.

As shown in FIGS. 1 to 3, the HDD comprises a flat and substantially rectangular housing 10. The housing 10 comprises a base 12 in the shape of a rectangular box whose upper surface is open, an inner cover (first cover) 14 which is secured to the base 12 by a plurality of screws 15 and closes an upper end opening of the base 12, and an outer cover (second cover) 16 which is located above the inner cover 14, and whose peripheral edge portion is welded to the base 12. The base 12 comprises a rectangular bottom wall 12a opposing the inner cover 14 with a gap therebetween, and sidewalls 12b standing along edges of the bottom wall 12a, which are formed integrally as one body from an aluminum alloy. The sidewalls 12b include a pair of long sidewalls 13a opposing each other and a pair of short sidewalls 13b opposing each other. An inner surface of one of the short sidewalls 13b and an inner side surface of about  $\frac{2}{3}$  region of each long sidewall 13a are formed into an arcuate shape curved along an outer circumferential edge of a magnetic disk 18, which will be described later. A substantially rectangular frame-shaped fixing rib 12c is provided on an upper end surface 38 of each sidewall 12b. The fixing rib 12c is formed integrally with the respective sidewall 12b as one body, thus constituting a part of the sidewall 12b. The fixing rib 12c will be described in detail later. The region of the upper end surface 38 which is located inside the fixing rib 12c constitutes a mounting surface (38) on which the inner cover is arranged.

The inner cover 14 is formed into a rectangular plate-shape from stainless steel, for example. The inner cover 14 has a shape and dimensions corresponding to those of the fixing rib 12c of the base 12. That is, the inner cover 14 has an outer circumferential shape corresponding to the inner circumferential shape of the fixing rib 12c and is formed to have outer dimensions slightly less than inner dimensions of the fixing rib 12c. As shown in FIG. 4, a rectangular frame-shaped gasket 17 or a sealing material is provided on an inner surface of the inner cover 14. The gasket 17 extends near and all along the outer circumferential edge of the inner cover 14. The gasket 17 is formed by applying a sealing material, for example, UV-curing resin or the like by a predetermined width on the inner surface of the inner cover 14, followed by curing.

As shown in FIGS. 2 and 3, the inner cover 14 is disposed on the upper end surface (the mounting surface) 38 of the sidewalls 12b and on an inner side of the fixing rib 12c. The circumferential portion of the inner cover 14 is placed on the mounting surface 38 of the sidewalls 12b via the gasket 17. A plurality of locations of the circumferential portion of the

inner cover **14**, that is, for example, four corner portions and a longitudinal central portion, are screwed to the upper end surfaces **38** of the sidewalls **12b** with screws **15**. Thus, the inner cover **14** airtightly closes the upper opening of the base **12**. The side edges (side surfaces) of the inner cover **14** oppose the inner side surface (second surface) of the fixing rib **12c** with a slight gap therebetween.

The fixing rib **12c** is formed to have a height greater than the thickness of the inner cover **14**. As shown in FIG. 2, in the state where the inner cover **14** is attached to the base **12**, the fixing rib **12c** protrude up over the inner cover **14**.

As shown in FIGS. 1 and 2, the outer cover **16** is formed into a rectangular plate shape from aluminum alloy, for example. The outer cover **16** has an outer circumferential shape and dimensions substantially equal to the outer circumferential shape and outer dimensions of the fixing rib **12c**. That is, the outer cover **16** is formed to be slightly greater in dimensions than the inner cover **14**. The outer cover **16** is disposed on the fixing rib **12c**, to cover the inner cover **14**. The peripheral portion of the outer cover **16** is welded to the fixing rib **12c** all around thereof and fixed airtightly to the base **12**.

In the inner cover **14** and the outer cover **16**, vent holes **46** and **48** through which the interior of the housing **10** and the exterior of the housing **10** are communicated with each other are formed, respectively. The air in the housing **10** is exhausted through the vent holes **46** and **48**, and further, through these vent holes **46** and **48**, a low-density gas (inert gas) having a density lower than that of air, for example, a helium, is enclosed in the housing **10**. Then, a sealant (a sealing body) **50** is attached to the outer surface of the outer cover **16** so as to close the vent hole **48**.

As shown in FIG. 3, in the housing **10**, a plurality of magnetic disks **18** as recording media, and a spindle motor **20** as a drive unit which supports and rotates the magnetic disks **18** are provided. The spindle motor **20** is disposed on the bottom wall **12a**. Each magnetic disk **18** is formed so as to have a diameter of, for example, 95 mm and comprises a magnetic recording layer on the upper surface and/or lower surface. The magnetic disks **18** are engaged coaxially with a hub (not shown) of the spindle motor **20**, clamped by a clamp spring **27**, and thereby fixed to the hub. In this manner, the magnetic disks **18** are supported in parallel to the bottom wall **12a** of the base **12**. The magnetic disks **18** are rotated at a predetermined number of revolutions by the spindle motor **20**.

In this embodiment, five magnetic disks **18**, for example, are accommodated in the housing **10**. But, the number of magnetic disks **18** is not limited to five, and can be increased or decreased. Further, a single magnetic disk **18** may be accommodated in the housing **10**.

In the housing **10**, a plurality of magnetic heads **31**, which record and reproduce information on and from the magnetic disks **18**, and a head actuator assembly **22**, which supports the magnetic heads **31** such that they are movable with respect to the magnetic disks **18**, are provided. Further, the housing **10** accommodates a voice coil motor (hereinafter referred to as VCM) **24** which rotates and positions the head actuator assembly **22**, a ramped loading mechanism **25** which holds the magnetic heads **31** at an unloading position away from the magnetic disks **18** when the magnetic heads **31** are moved to the outermost circumference of the magnetic disks **18**, and a board unit **21** on which electronic components including a conversion connector are mounted.

The head actuator assembly **22** includes an actuator block in which a bearing unit **28** is built, a plurality of arms **30** extending from the actuator block, and a suspension **34**

extending from each of the arms **30**, and the magnetic head **31** is supported by the distal end portion of each of the suspensions **34**. The head actuator assembly **22** is supported pivotably by a pivot disposed to stand on the bottom wall **12a** via the bearing unit **28**.

Onto the outer surface of the bottom wall **12a**, a printed circuit board (not shown) is fixed by screws. A control unit is formed on the printed circuit board and the control unit controls the operation of the spindle motor **20**, and also controls the operation of the VCM **24** and the magnetic heads **31** via the board unit **21**.

Next, the structure of the fixing rib **12c** and the structure of a welded portion will be described in detail.

FIG. 5 is an exploded and enlarged perspective view of a recess portion of the base and a protruding portion of the inner cover. FIG. 6 is a cross sectional view of the HDD taken along line A-A of FIG. 1. FIG. 7 is a cross sectional view of the HDD taken along line B-B of FIG. 1.

As shown in FIGS. 3 and 5 to 7, the rectangular frame-shaped fixing rib **12c** provided integrally on the upper end surfaces **38** of the sidewalls **12b** comprises a flat ceiling surface (welding surface) (first surface) SW having a fixed height T1 all along the entire circumference. The fixing rib **12c** is, in its most part, formed as a first area (broad portion) **30a** having a first width W1 which is fixed. At least a portion of the fixing rib **12c**, in this embodiment, three locations thereof constitute a narrow region (second region) **30b** having a second width W2, which is less than the first width W1. The three narrow regions **30b** are provided in three locations, which includes two locations on the right and left side of the long sidewall **13a** located most adjacent to the outer circumferential edge of the magnetic disk **18** and the central portion of one short sidewall **13b**. The narrow regions **30b** are each formed by, for example, cutting the inner surface (second surface) of the fixing rib **12c**, which is on the side of the magnetic disk **18**, into a long and slender rectangular recess portion **32**, to narrow down the width of the fixing rib **12c**. The recess portions **32** are each recessed in a direction away from the magnetic disk **18**, to have a depth of, for example, about 0.1 to 0.3 mm. With the recess portions **32** thus provided, a bottom surface of each recess portion **32** serves as an installation surface flush with the mounting surface **38**, and thus it becomes possible to keep wide the width of the mounting surface **38** abutted to the gasket **17** of the inner cover **14**. The longitudinal length L1 of each narrow region **30b** is, for example, about 20 to 40 mm. The length L1 is arbitrarily settable and can be changed if needed.

The inner circumferential corner portions of the fixing rib **12c**, i.e., the corner portions where the ceiling surface and the inner surface intersect each other, are each cut off at a predetermined angle, to form a C surface (chamfered surface) (third surface) CH having a predetermined width. The C surface CH is formed all around the circumference of the fixing rib **12c** in both of the first region **30a** and the second region **30b**. In this case, a width CW2 of the C surface CH in the second region **30b** is less than a width CW1 of the C surface CH in the first region **30a**. Thus, the flat ceiling surface (welding surface) (first side) SW which remains in the fixing rib **12c** is formed to have a fixed width W3 all around the entire circumference. That is, in any region of the first region **30a** and the narrow regions **30b**, a welding surface SW having the width W3 is maintained.

The peripheral portion of the outer cover **16** is placed on the welding surface SW of the fixing rib **12c** and welded to the welding surface SW by, for example, laser welding. The welding surface SW is formed to have a fixed width W3 all

5

around the entire circumference of the fixing rib **21c** and the welding surface SW of the constant width **W3** is maintained in each narrow region **30b** as well. With this structure, the peripheral portion of the outer cover **16** can be welded to the fixing rib **12c** in a stable manner, and the first region **30a** and the second region **30b** can maintain high welding quality. Although the width **W3** of the welding surface SW may slightly vary upon welding the outer cover **16** to the welding surface SW, the welding surface SW maintains a substantially fixed width **W3** all around the entire circumference of the fixing rib after welding.

On the other hand, as shown in FIGS. 2 and 5 to 7, the inner cover **14** comprises three projecting portions **40** integrated to the cover **14**, which respectively correspond to the recess portions **32** of the fixing rib **21c**. In other words, the projecting portions **40** are formed respectively in the long sides and a central portion of a short side of the inner cover **14**. The length and the height of each projecting portion **40** are set slightly less than the length and recession of the recess portions (narrow regions) **32**. The projection height is, for example, about 0.1 to 0.2 mm.

As shown in FIG. 4, the gasket **17** provided on the inner surface of the inner cover **14** is turned outwards in the locations of the projecting portions, and extends along the end edges of the projecting portions. While the inner cover **14** is fixed by screwed to the upper end surfaces (mounting surfaces) **38** of the sidewalls **12b**, the projecting portions **40** are located in the respective recess portions **32** of the corresponding narrow regions **30b**, and further tightly attached onto the mounting surface **38** via the gasket **17**.

According to the HDD configured as described above, even in the case where the diameter of the magnetic disk **18** is increased and the thickness of the sidewalls **12b** of the base **12** is decreased, recess portions **32** are made in locations of the fixing rib **21c**, which correspond to the thin portions, to form the narrow regions **30b**, and further the chamfer width of the narrow regions **30b** is set less than the chamfer width of the first regions **30a**. In this manner, a sufficient width of the welding surface can be maintained for the fixing rib. Thus, the peripheral portion of the outer cover **16** can be welded to the sidewalls **12b** of the base **12** while maintaining high welding quality all around the entire circumference. Therefore, the magnetic disk can be increased in diameter and the storage capacity can be increased while maintaining the welding quality. Moreover, with the recess portions **32** thus provided, the width of the mounting surfaces can be expandable by the depth of the recess portions **32**. With this structure, even in the regions where the sidewalls **12b** are thin, the gasket **17** of the inner cover **14** is reliably brought into contact with the mounting surfaces of the sidewalls, thereby making it possible to keep high airtightness. At the same time, the gasket **17** can be disposed to be apart from the outer circumferential edge of the magnetic disk **18** by only a predetermined distance.

In the embodiment described above, the C surface is formed all around the entire circumference of the fixing rib **21c**, burrs and the like, which may be produced at the time of manufacture can be removed, and therefore the flatness of the welding surface SW can be secured. Therefore, it is possible to suppress the degrading of the flatness of the welding surface or deterioration in welding quality, caused by burrs.

Next, an HDD according to another embodiment will be described. In the embodiment to be described below, the same structural members will be denoted by the same reference numbers as those of the first embodiment provided above, and the detailed explanations thereof will be omitted.

6

Only the parts different from those of the first embodiment will be mainly described in detail.

### Second Embodiment

FIG. 8 is a partially enlarged perspective view showing a base of an HDD according to the second embodiment and FIG. 9 is a cross-sectional view schematically showing the base to illustrate a step of processing sidewalls of the base.

As shown in FIG. 8, only the first region **30a** of the fixing rib **21c** provided on a sidewall **12b** may be chamfered to form a C surface (third surface) CH without chamfering the narrow region **30b**. In other words, such a structure that the narrow region **30b** does not comprise a C surface may be accepted. When not chamfering, there may be a case where burrs remain in a corner portion of the narrow region **30b**. To avoid this, when processing the fixing rib **12c** of the base **12**, it is preferable to, first, cut the surface where burrs are created in the narrow region **30b** to remove the burrs, and thereafter cut the other surfaces as shown in FIG. 9. For example, when burrs are created on the welding surface SW of the narrow region **30b**, it is preferable to cut the welding surface CW first, and then cut the inner side surface of the fixing rib **21c**, that is, the bottom surface of the recess portion **32**. On the other hand, when burrs are created on the inner surface of the fixing rib **21c**, it suffices if the inner side surface is cut first, and then the welding surface CW is cut.

While certain embodiments have been described, these embodiments have been presented by way of example only, and are not intended to limit the scope of the inventions. Indeed, the novel embodiments described herein may be embodied in a variety of other forms; furthermore, various omissions, substitutions and changes in the form of the embodiments described herein may be made without departing from the spirit of the inventions. The accompanying claims and their equivalents are intended to cover such forms or modifications as would fall within the scope and spirit of the inventions.

The locations where the narrow regions are formed in the fixing rib of the housing are not limited to those of the embodiments provided above, but these regions may be provided in any locations. Further, the narrow regions of the fixing rib are not limited to three, but there may be one, or two or four or more regions. The materials, shapes and sizes of elements constituting the disk drive can be changed as needed. In the magnetic disk device, the number of magnetic disks and magnetic heads can be changed as needed. The size of the magnetic disks can be selected in various ways.

What is claimed is:

1. A disk device comprising:
  - a disk-shaped recording medium;
  - a base accommodating the recording medium, the base comprising a bottom wall, a sidewall on a peripheral portion of the bottom wall, and a rib on a part of an upper surface of the sidewall, the rib comprising a first region with a first width and a second region with a second width less than the first width, a first chamfered surface with a first chamfered width in the first region, and a second chamfered surface with a second chamfered width which is less than the first chamfered width in the second region, the first region and the second region being located corresponding to a side portion of the recording medium;
  - a first cover provided on a part of the upper surface of the sidewall; and
  - a second cover provided on the rib and provided above the first cover.

2. The disk device of claim 1, wherein the rib comprises a first surface with a fixed width around an entire circumference of the rib, and a second surface provided on an inner side portion of the rib, and the first chamfered surface and the second chamfered surface 5 are provided between the first surface and the second surface.
3. The disk device of claim 1, wherein the rib comprises a recess portion in which the second region comprises a bottom portion, and 10 the first cover comprises, in an outer peripheral portion thereof, a projecting portion corresponding to the recess portion of the rib.
4. The disk device of claim 1, wherein the sidewall of the base comprises a pair of long side- 15 walls, and a pair of short sidewalls, and the second region of the rib is provided on each of the long sidewalls and one of the short sidewalls.
5. The disk device of claim 1, wherein a gas of a density lower than that of air is sealed with the 20 base and the first cover.
6. The disk device of claim 1, wherein the second region is more closer to the side portion of the recording medium than the first region.
7. The disk device of claim 1, wherein 25 the rib is formed integrally with the sidewall.

\* \* \* \* \*