

US010797698B1

(12) **United States Patent**
Droz et al.

(10) **Patent No.:** **US 10,797,698 B1**
(45) **Date of Patent:** **Oct. 6, 2020**

(54) **SYSTEMS AND METHODS FOR SELECTING LIGHT EMITTERS FOR EMITTING LIGHT**

(56) **References Cited**

- (71) Applicant: **Waymo LLC**, Mountain View, CA (US)
- (72) Inventors: **Pierre-yves Droz**, Los Altos, CA (US); **Augusto Tazzoli**, San Jose, CA (US); **Michael Marx**, Mountain View, CA (US)
- (73) Assignee: **Waymo LLC**, Mountain View, CA (US)

U.S. PATENT DOCUMENTS

6,847,169 B2 *	1/2005	Ito	H05B 45/46 315/77
7,733,034 B2 *	6/2010	Kotikalapoodi	H05B 45/37 315/294
8,669,934 B2 *	3/2014	Sasaki	H05B 45/37 345/102
8,749,163 B2 *	6/2014	Phadke	H05B 45/50 315/291
8,917,029 B2 *	12/2014	Chu	H05B 45/37 315/224
9,614,452 B2 *	4/2017	Jin	H02M 3/33561
9,655,174 B2 *	5/2017	Qu	H05B 45/35
9,860,946 B2 *	1/2018	LoCascio	H05B 45/44

(*) Notice: Subject to any disclaimer, the term of this patent is extended or adjusted under 35 U.S.C. 154(b) by 0 days.

* cited by examiner

Primary Examiner — Kenneth B Wells
(74) *Attorney, Agent, or Firm* — McDonnell Boehnen Hulbert & Berghoff LLP

(21) Appl. No.: **16/699,438**

(57) **ABSTRACT**

(22) Filed: **Nov. 29, 2019**

An example circuit includes a plurality of light emitters connected in parallel between a first node and a second node. The circuit also includes a plurality of capacitors, with each capacitor corresponding to one of the light emitters, and a plurality of discharge-control switches, with each discharge-control switch corresponding to one of the capacitors. The circuit further includes a pulse-control switch connected to the plurality of light emitters. During a first period, the pulse-control switch restricts current flow, and each of the plurality of capacitors is charged via the first node. During a second period, one or more of the plurality of discharge-control switches allows current flow that discharges one or more corresponding capacitors. During a third period, the pulse-control switch allows current flow that discharges one or more undischarged capacitors of the plurality of capacitors through one or more corresponding light emitters.

- (51) **Int. Cl.**
H05B 33/08 (2020.01)
H05B 37/02 (2006.01)
H05B 41/00 (2006.01)
H03K 17/969 (2006.01)
H03K 17/0412 (2006.01)
H05B 45/00 (2020.01)

- (52) **U.S. Cl.**
CPC **H03K 17/969** (2013.01); **H03K 17/04123** (2013.01); **H05B 45/00** (2020.01)

- (58) **Field of Classification Search**
CPC . H03K 17/969; H03K 17/04123; H05B 45/00
See application file for complete search history.

20 Claims, 8 Drawing Sheets

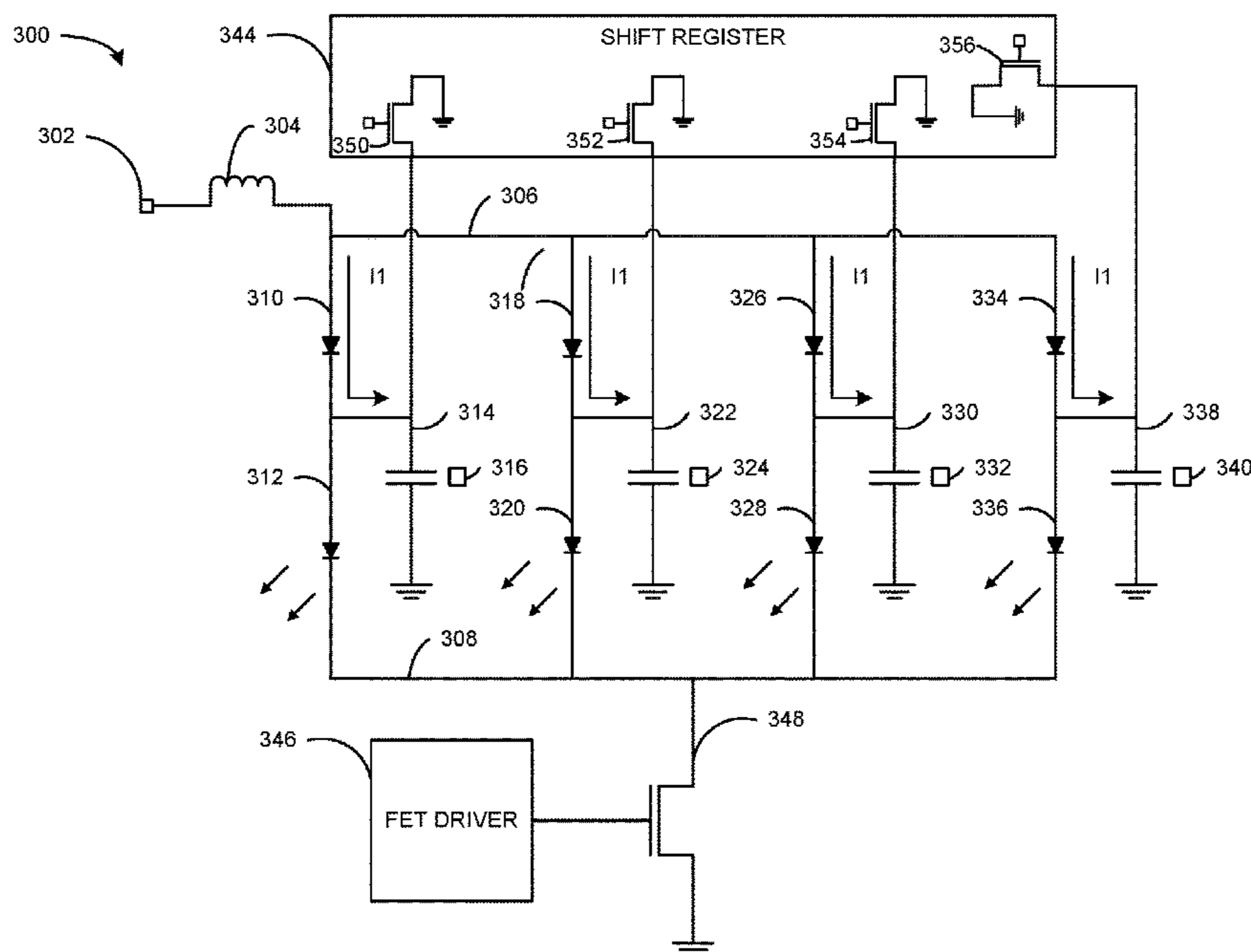

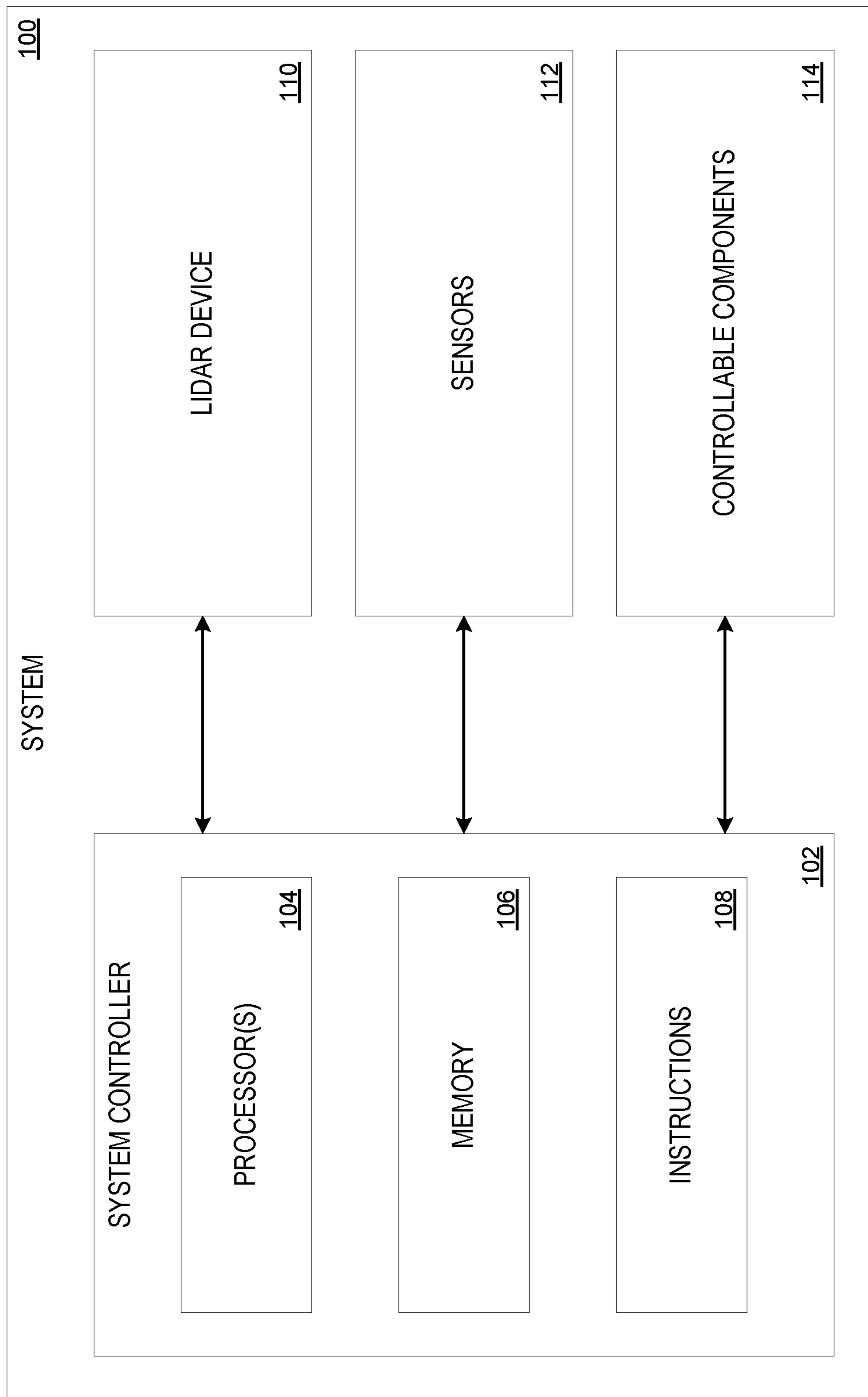

FIGURE 1A

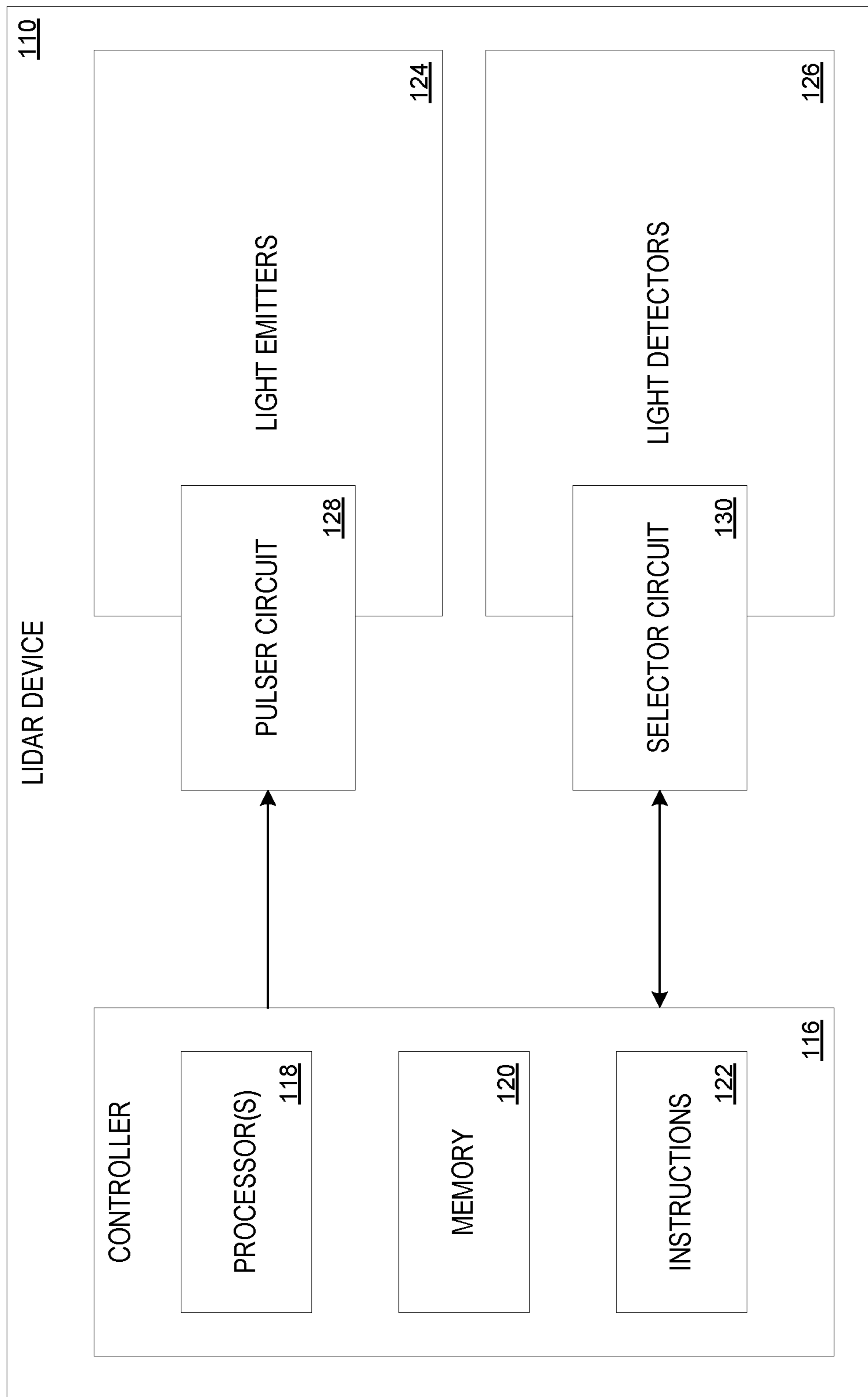

FIGURE 1B

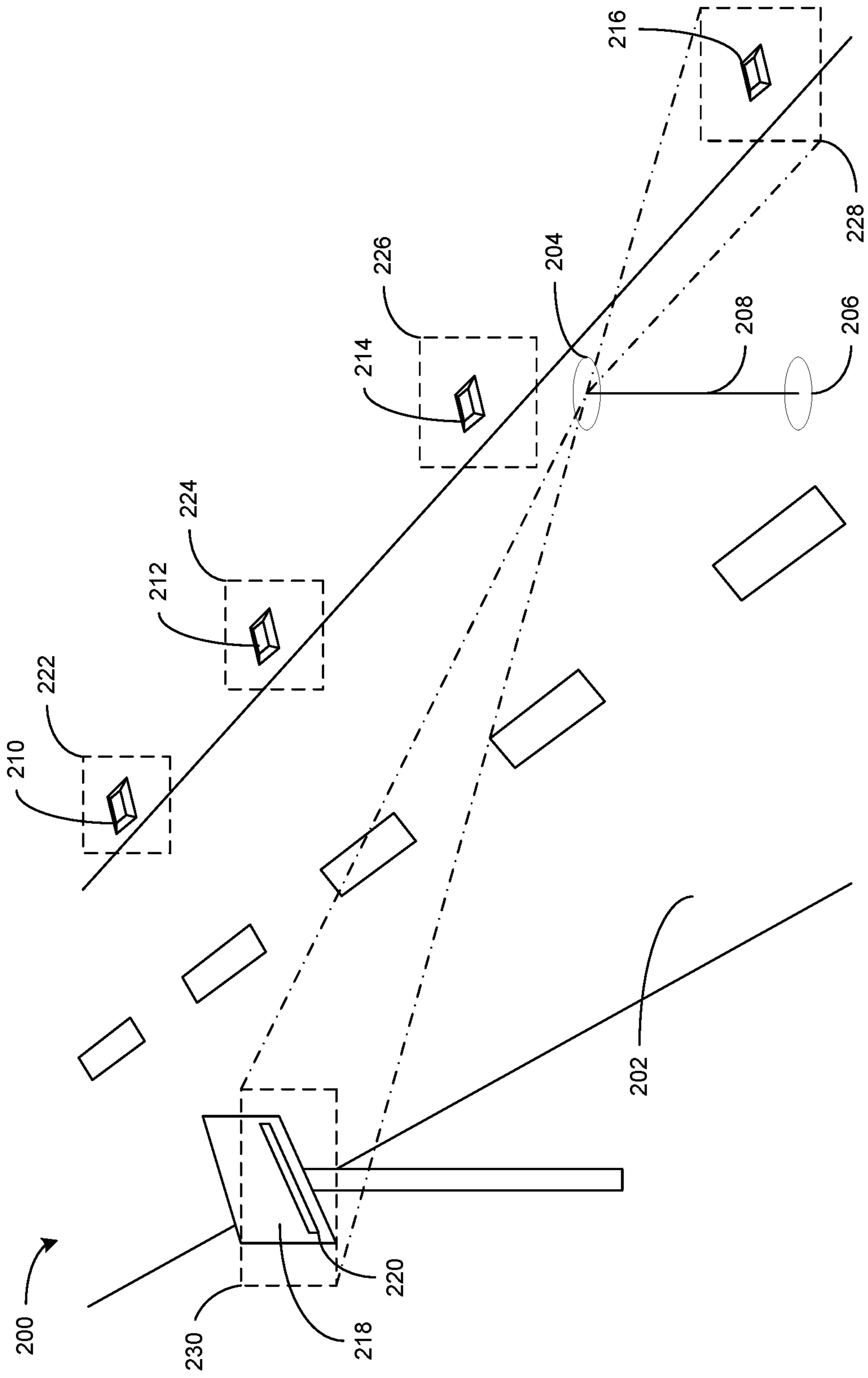

FIGURE 2

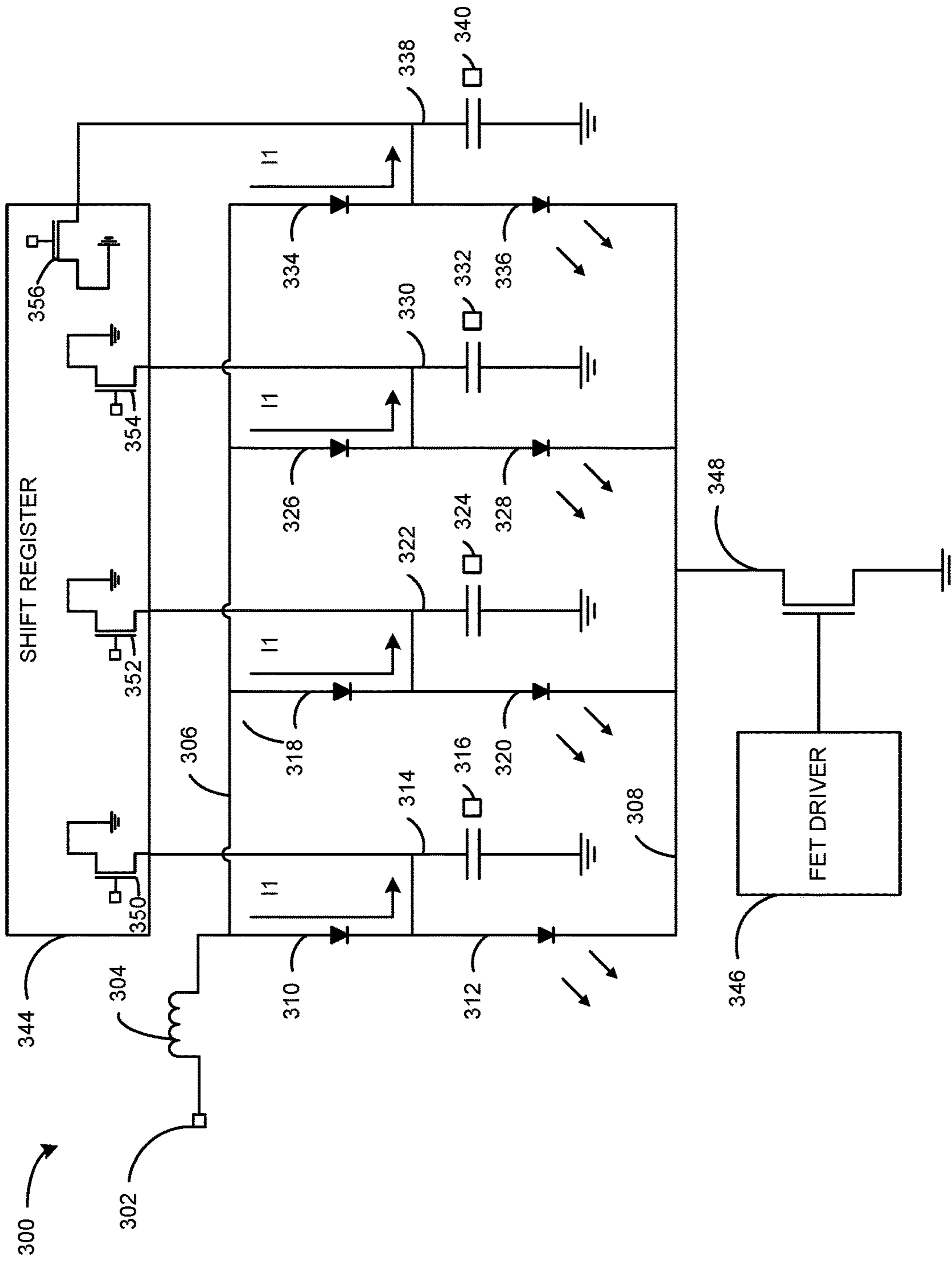

FIGURE 3A

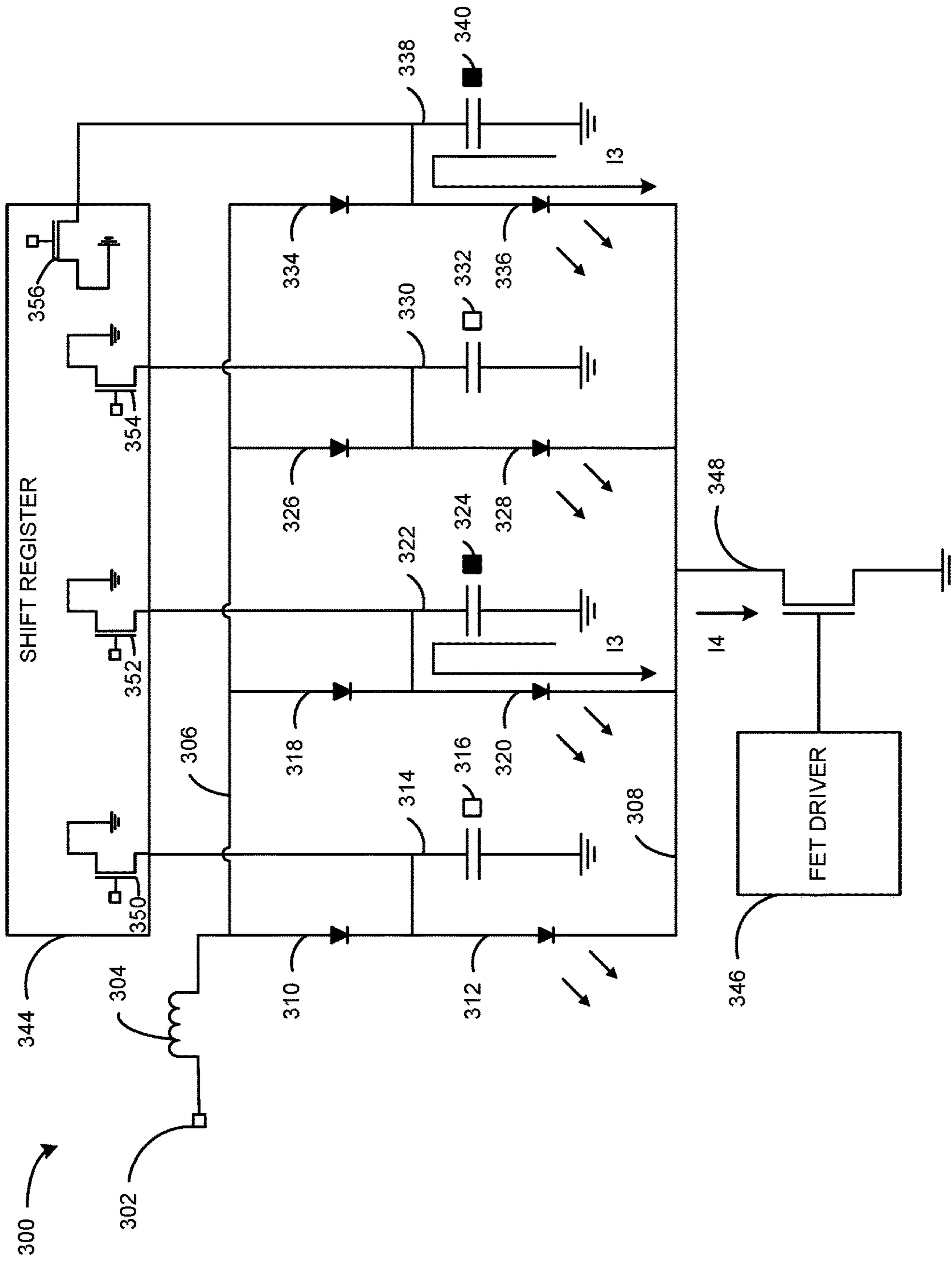

FIGURE 3C

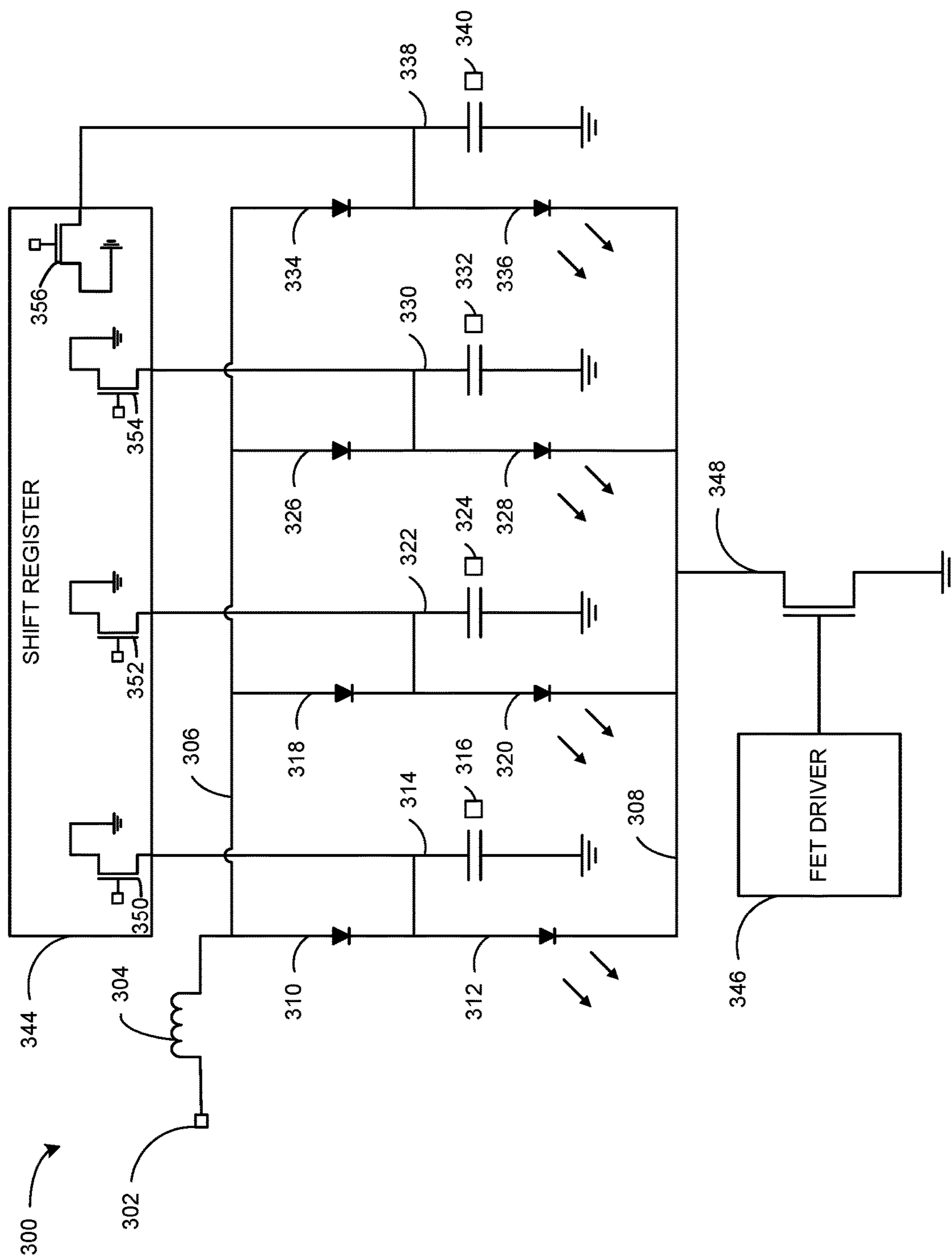

FIGURE 3D

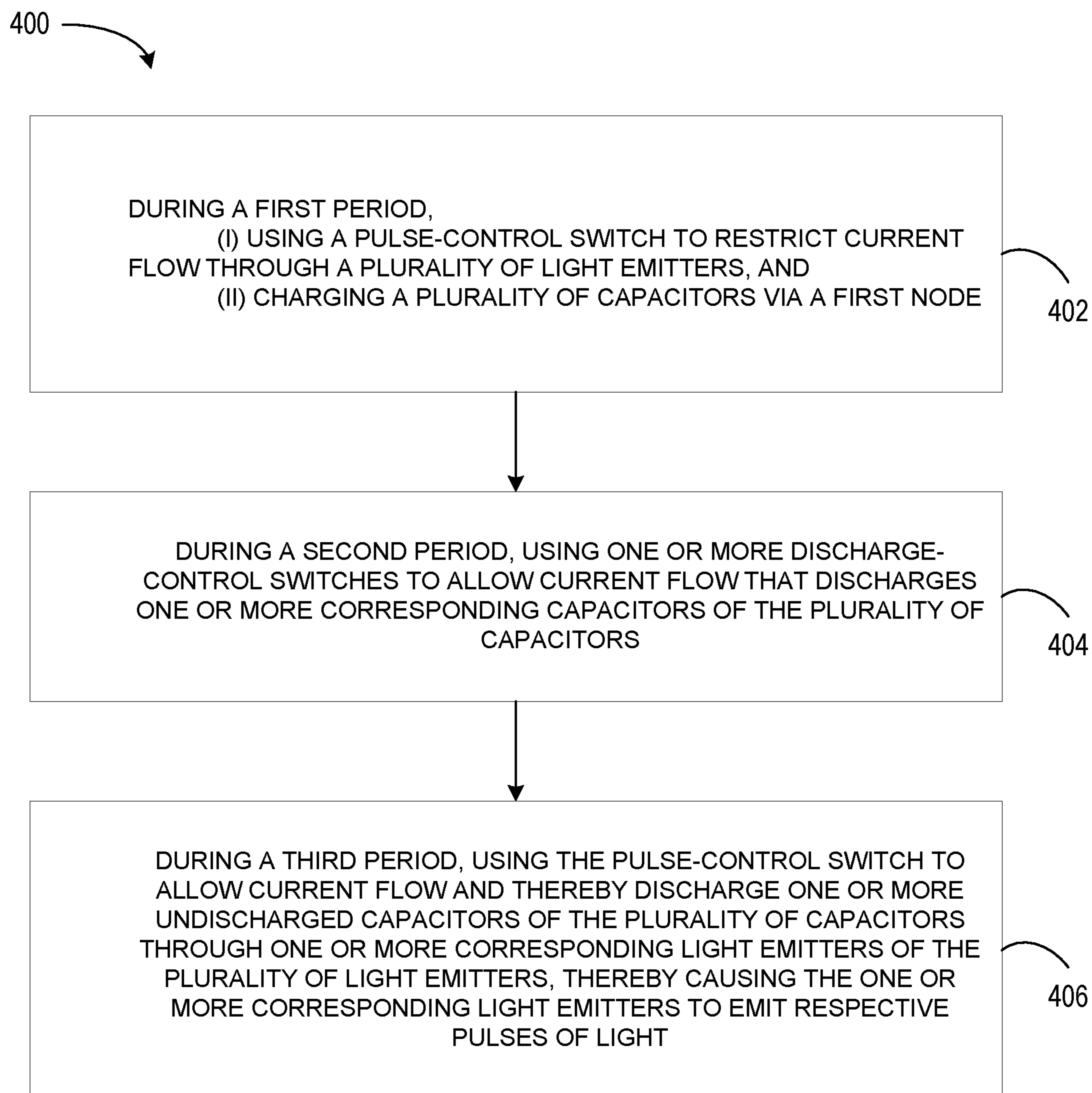

FIGURE 4

SYSTEMS AND METHODS FOR SELECTING LIGHT EMITTERS FOR EMITTING LIGHT

BACKGROUND

Unless otherwise indicated herein, the materials described in this section are not prior art to the claims in this application and are not admitted to be prior art by inclusion in this section.

A Light Detection and Ranging (LIDAR) device is used for sensing aspects of an environment. A plurality of light emitters emit light to an environment surrounding the device, and a plurality of light detectors detect reflected light. Based on time differences between light emissions and receiving the reflected light, the LIDAR device can generate three-dimensional (3D) point cloud data that can be interpreted to render a representation of the environment.

Conditions might exist where it is desirable to sense some portions of the environment but not others. For example, reflections from some objects in the environment (e.g., retroreflectors) might interfere with sensing neighboring portions of the environment.

SUMMARY

In a first example, a circuit is provided. The circuit includes a plurality of light emitters connected in parallel between a first node and a second node. The circuit includes a plurality of capacitors, wherein each capacitor in the plurality of capacitors corresponds to a respective light emitter in the plurality of light emitters. The circuit includes a plurality of discharge-control switches, wherein each discharge-control switch corresponds to a respective capacitor in the plurality of capacitors. The circuit includes a pulse-control switch connected to the plurality of light emitters. During a first period, the pulse-control switch restricts current flow and each capacitor in the plurality of capacitors is charged via the first node. During a second period, one or more of the plurality of discharge-control switches allows current flow that discharges one or more corresponding capacitors of the plurality of capacitors. During a third period, the pulse-control switch allows current flow that discharges one or more undischarged capacitors of the plurality of capacitors through one or more corresponding light emitters of the plurality of light emitters, thereby causing the one or more corresponding light emitters to emit respective pulses of light.

In a second example, a method is provided. The method includes, during a first period, (i) using a pulse-control switch to restrict current flow through a plurality of light emitters, and (ii) charging a plurality of capacitors via a first node. The method includes, during a second period, using one or more discharge-control switches to allow current flow that discharges one or more corresponding capacitors of the plurality of capacitors. The method includes, during a third period, using the pulse-control switch to allow current flow and thereby discharge one or more undischarged capacitors of the plurality of capacitors through one or more corresponding light emitters of the plurality of light emitters, thereby causing the one or more corresponding light emitters to emit respective pulses of light.

In a third example, a non-transitory computer readable medium is provided. The non-transitory computer readable medium has instructions stored thereon that when executed by a processor cause performance of a set of functions. The set of functions includes, during a first period, (i) using a pulse-control switch to restrict current flow through a plu-

rality of light emitters, and (ii) charging a plurality of capacitors via a first node. The set of functions includes, during a second period, using one or more discharge-control switches to allow current flow that discharges one or more corresponding capacitors of the plurality of capacitors. The set of functions includes, during a third period, using the pulse-control switch to allow current flow and thereby discharge one or more undischarged capacitors of the plurality of capacitors through one or more corresponding light emitters of the plurality of light emitters, thereby causing the one or more corresponding light emitters to emit respective pulses of light.

In a fourth example, a method for scanning an environment of an autonomous vehicle is provided. The method may include determining portions of the environment that may include retroreflectors. The method may further include selectively disabling capabilities of a LIDAR to scan those portions. The method may further include scanning other portions of the of the environment with the LIDAR. Selectively disabling capabilities of the LIDAR to scan those portions may include selectively preventing the LIDAR from transmitting light to those portions of the environment that may include retroreflectors. Selectively preventing the LIDAR from transmitting light to those portions of the environment that may include retroreflectors may include selectively preventing one or more transmitters (e.g., light emitters, such as laser diodes) from emitting light at a certain time.

These as well as other aspects, advantages, and alternatives will become apparent to those of ordinary skill in the art by reading the following detailed description with reference where appropriate to the accompanying drawings. Further, it should be understood that the description provided in this summary section and elsewhere in this document is intended to illustrate the claimed subject matter by way of example and not by way of limitation.

BRIEF DESCRIPTION OF THE FIGURES

FIG. 1A is a block diagram of a system including a LIDAR device, according to an example embodiment.

FIG. 1B is a block diagram of a LIDAR device, according to an example embodiment.

FIG. 2 illustrates an environment of a LIDAR device, according to an example embodiment.

FIG. 3A illustrates a pulser circuit of a LIDAR device at a first time, according to an example embodiment.

FIG. 3B illustrates a pulser circuit of a LIDAR device at a second time, according to an example embodiment.

FIG. 3C illustrates a pulser circuit of a LIDAR device at a third time, according to an example embodiment.

FIG. 3D illustrates a pulser circuit of a LIDAR device at a fourth time, according to an example embodiment.

FIG. 4 is a block diagram of a method, according to an example embodiment.

DETAILED DESCRIPTION

Example methods, devices, and systems are described herein. It should be understood that the words “example” and “exemplary” are used herein to mean “serving as an example, instance, or illustration.” Any embodiment or feature described herein as being an “example” or “exemplary” is not necessarily to be construed as preferred or advantageous over other embodiments or features. Other

embodiments can be utilized, and other changes can be made, without departing from the scope of the subject matter presented herein.

Thus, the example embodiments described herein are not meant to be limiting. Aspects of the present disclosure, as generally described herein, and illustrated in the figures, can be arranged, substituted, combined, separated, and designed in a wide variety of different configurations, all of which are contemplated herein.

Further, unless context suggests otherwise, the features illustrated in each of the figures may be used in combination with one another. Thus, the figures should be generally viewed as component aspects of one or more overall embodiments, with the understanding that not all illustrated features are necessary for each embodiment.

By the term “about” or “substantially” with reference to amounts or measurement values described herein, it is meant that the recited characteristic, parameter, or value need not be achieved exactly, but that deviations or variations, including for example, tolerances, measurement error, measurement accuracy limitations and other factors known to those of skill in the art, may occur in amounts that do not preclude the effect the characteristic was intended to provide.

I. Overview

A LIDAR device can include one or a plurality of light emitters that can emit pulses of light. For example, the light emitter may be a laser diode. A selector circuit can be used to select which of the light emitters are used to emit light and which are not. For example, it may be desirable that one or more of the light emitters are not used to emit light in order to avoid illuminating retroreflectors or other highly-reflective surfaces. Such surfaces may flood light detectors on the LIDAR device with reflected portions of light emitted from the light emitters and thus impede aspects of representing the received reflected portions of light and interpreting resulting data. For example, this may introduce ambiguity in determining 3D point cloud data or may bias data-processing operations that use the 3D point cloud data, such as edge-detection or object detection operations.

In an example embodiment, the pulser circuit includes a plurality of laser diodes that are connected in parallel. For example, the laser diodes could all have a common cathode (e.g., a device may include eight laser diode bars with a common cathode), or the cathodes of the laser diodes could be connected together at a cathode node. The common cathode or cathode node is connected to the drain of a pulse-control switch (e.g., a transistor, such as a GaNFET or other type of field-effect transistor, a bipolar transistor, a control switch, a limit switch, or another type of switching device configured to alternatively allow or stop current flow in a circuit). For example, the pulse-control switch may be a pulse-control transistor. In such examples, the source of the pulse-control transistor is connected to ground. The gate of the pulse-control transistor is connected to a driver circuit. The anode of each laser diode is connected to the cathode of a respective charging diode, a respective capacitor, and a respective discharge-control switch. The pulser circuit further includes an inductor. One end of the inductor is connected to an adjustable voltage source. The other end of the inductor is connected to the anodes of the charging diodes.

The pulser circuit can be operated in accordance with a repeating pulse period, each pulse period corresponding to emissions of light from the light emitters. Each pulse period, in turn, can include a first period (i.e., a charging period), a second period (i.e., a selective discharge period), and a third period (i.e., a pulse emission period). During the charging period, the pulse-control switch is off, all of the discharge-

control switches are off, and the voltage source is turned on. The voltage source causes a current to flow through the inductor, which charges each of the capacitors through their associated charging diodes. During the selective discharge period, one or more of the discharge-control switches are turned on, thereby discharging the associated capacitors. During the pulse emission period, the pulse-control switch is turned on, which causes the capacitors that have not already been discharged to discharge through their associated laser diodes and the pulse-control switch. As a result, a discharge current flows through each laser diode that has not had its associated capacitor discharged during the selective discharge period, thereby causing each such laser diode to emit a pulse of light.

In some examples, a shift register is used to control the discharge-control switches. For example, the discharge-control switches can be transistors or other switching devices. Accordingly, as referred to herein, the term functionality described with respect to a “discharge-control transistor” can also be achieved using other types of switching devices, such as switches. In this approach, the shift register is loaded with data (e.g., N bits of data for N laser diodes, or N bits of data for 2^N switches, depending on the encoding of the shift register), with each bit of data determining whether the discharge-control switch for a particular laser diode is to be turned on during the selective discharge period or remain off. For example, a “1” may indicate that a discharge-control switch is to be turned on and a “0” may indicate that a discharge-control switch is to remain off, or vice versa. The outputs of the shift register are connected to the gates of the discharge-control switches, and thereby select which capacitors to discharge during the selective discharge period, and by proxy, select which capacitors that remain charged and are capable of discharging during the pulse emission period.

In some examples, the adjustable voltage source can be controlled to apply different voltages to the inductor. For example, in a default mode of operation, the adjustable voltage source may be controlled to apply a voltage V1 to the inductor, which causes each of the capacitors to charge up to a voltage of Vcap1 (e.g., Vcap1 could be about $2 \times V1$). When the capacitors discharge through their respective laser diodes, the emitted light pulses may have a first peak power level. However, for short periods of time (e.g., based on thermal constraints), the adjustable voltage source may be controlled to apply a voltage V2 to the inductor in which $V2 > V1$. This causes the capacitors to charge up to a higher voltage, Vcap2 (e.g., Vcap2 could be about $2 \times V2$). And, when the capacitors discharge through their respective laser diodes, the emitted light pulses may have a second, higher peak power level. Controlling the voltage levels of the capacitors may alternatively or additionally involve applying a voltage for a period of time associated with charging the capacitor (i.e., a “charging period”). For example, a desired power level of a light pulse can be determined that is associated with a charge level of the capacitors. The capacitors may be charged for a period of time (e.g., based on a known capacitance of the capacitors and the applied voltage) associated with the power level. In this manner, a power level of each light pulse can be precisely controlled by setting the charging period for the capacitors. Additionally or alternatively, each charged capacitor can be discharged by a predetermined amount prior to the emission period to achieve a desired voltage level and thereby control a power level of each light pulse.

II. Example Systems

FIG. 1A is a block diagram of a system including a LIDAR device, according to an example embodiment. In particular, FIG. 1A shows a system **100** that includes a system controller **102**, a LIDAR device **110**, a plurality of sensors **112**, and a plurality of controllable components **114**. System controller **102** includes processor(s) **104**, a memory **106**, and instructions **108** stored on the memory **106** and executable by the processor(s) **104** to perform functions.

The processor(s) **104** can include one or more processors, such as one or more general-purpose microprocessors and/or one or more special purpose microprocessors. The one or more processors may include, for instance, an application-specific integrated circuit (ASIC) or a field-programmable gate array (FPGA). Other types of processors, computers, or devices configured to carry out software instructions are contemplated herein.

The memory **106** may include a computer readable medium, such as a non-transitory computer readable medium, which may include without limitation, read-only memory (ROM), programmable read-only memory (PROM), erasable programmable read-only memory (EPROM), electrically erasable programmable read-only memory (EEPROM), non-volatile random-access memory (e.g., flash memory), a solid state drive (SSD), a hard disk drive (HDD), a Compact Disc (CD), a Digital Video Disk (DVD), a digital tape, read/write (R/W) CDs, R/W DVDs, etc.

The LIDAR device **110**, described further below, includes a plurality of light emitters configured to emit light (e.g., in light pulses) and light detectors configured to detect light (e.g., reflected portions of the light pulses). The LIDAR device **110** may generate 3D point cloud data from outputs of the light detectors, and provide the 3D point cloud data to the system controller **102**. The system controller **102**, in turn, may perform operations on the 3D point cloud data to determine the characteristics of an environment (e.g., relative positions of objects within an environment, edge detection, object detection, proximity sensing, or the like).

Similarly, the system controller **102** may use outputs from the plurality of sensors **112** to determine the characteristics of the system **100** and/or characteristics of the environment. For example, the sensors **112** may include one or more of a Global Positioning System (GPS), an Inertial Measurement Unit (IMU), an image capture device (e.g., a camera), a light sensor, a heat sensor, and other sensors indicative of parameters relevant to the system **100** and/or the environment). The LIDAR device **110** is depicted as separate from the sensors **112** for purposes of example, and may be considered a sensor in some examples.

Based on characteristics of the system **100** and/or the environment determined by the system controller **102** based on the outputs from the LIDAR device **110** and the sensors **112**, the system controller **102** may control the controllable components **114** to perform one or more actions. For example, the system **100** may correspond to a vehicle, in which case the controllable components **114** may include a braking system, a turning system, and/or an accelerating system of the vehicle, and the system controller **114** may change aspects of these controllable components based on characteristics determined from the LIDAR device **110** and/or sensors **112** (e.g., when the system controller **102** controls the vehicle in an autonomous mode). Within examples, the LIDAR device **110** and the sensors **112** are also controllable by the system controller **102**.

FIG. 1B is a block diagram of a LIDAR device, according to an example embodiment. In particular, FIG. 1B shows a

LIDAR device **110**, having a controller **116** configured to control a plurality of light emitters **124** and a plurality of light detectors **126**. The LIDAR device **110** further includes a pulser circuit **128** configured to select and provide power to respective light emitters of the plurality of light emitters **124** and a selector circuit **130** configured to select respective light detectors of the plurality of light detectors **126**. The controller **116** includes processor(s) **118**, a memory **120**, and instructions **122** stored on the memory **120**.

Similar to processor(s) **104**, the processor(s) **118** can include one or more processors, such as one or more general-purpose microprocessors and/or one or more special purpose microprocessors. The one or more processors may include, for instance, an application-specific integrated circuit (ASIC) or a field-programmable gate array (FPGA). Other types of processors, computers, or devices configured to carry out software instructions are contemplated herein.

Similar to memory **106**, the memory **120** may include a computer readable medium, such as a non-transitory computer readable medium, such as, but not limited to, read-only memory (ROM), programmable read-only memory (PROM), erasable programmable read-only memory (EPROM), electrically erasable programmable read-only memory (EEPROM), non-volatile random-access memory (e.g., flash memory), a solid state drive (SSD), a hard disk drive (HDD), a Compact Disc (CD), a Digital Video Disk (DVD), a digital tape, read/write (R/W) CDs, R/W DVDs, etc.

The instructions **122** are stored on memory **120** and executable by the processor(s) **118** to perform functions related to controlling the pulser circuit **128** and the selector circuit **130**, for generating 3D point cloud data, and for processing the 3D point cloud data (or perhaps facilitating processing the 3D point cloud data by another computing device, such as the system controller **102**).

The controller **116** can determine 3D point cloud data by using the light emitters **124** to emit pulses of light. A time of emission is established for each light emitter and a relative location at the time of emission is also tracked. Aspects of an environment of the LIDAR device **110**, such as various objects, reflect the pulses of light. For example, when the LIDAR device **110** is in an environment that includes a road, such objects may include vehicles, signs, pedestrians, road surfaces, construction cones, or the like. Some objects may be more reflective than others, such that an intensity of reflected light may indicate a type of object that reflects the light pulses. Further, surfaces of objects may be at different positions relative to the LIDAR device **110**, and thus take more or less time to reflect portions of light pulses back to the LIDAR device **110**. Accordingly, the controller **116** may track a detection time at which a reflected light pulse is detected by a light detector and a relative position of the light detector at the detection time. By measuring time differences between emission times and detection times, the controller **116** can determine how far the light pulses travel prior to being received, and thus a relative distance of a corresponding object. By tracking relative positions at the emission times and detection times the controller **116** can determine an orientation of the light pulse and reflected light pulse relative to the LIDAR device **110**, and thus a relative orientation of the object. By tracking intensities of received light pulses, the controller **116** can determine how reflective the object is. The 3D point cloud data determined based on this information may thus indicate relative positions of detected reflected light pulses (e.g., within a coordinate system, such as a Cartesian coordinate system) and intensities of each reflected light pulse.

As described further below, the pulser circuit **128** is used for selecting light emitters for emitting light pulses. The selector circuit **130** similarly is used for sampling outputs from light detectors.

FIG. **2** illustrates an environment of a LIDAR device, according to an example embodiment. In particular, FIG. **2** shows an environment **200** that includes a road **202**, a LIDAR device (which is indicated schematically by a detection plane **204**), and a plurality of objects. The LIDAR device may be the same or similar to the LIDAR device **110**. The detection plane **204** is a simplified representation of the LIDAR device because, in practice, the LIDAR device may detect reflected portions of light pulses at multiple heights and angles. The LIDAR device is positioned at a height **208** relative to a road surface **206**. In this context, the road **202** may be considered an object. The objects in the environment **200** further include retroreflectors **210**, **212**, **214**, and **216**. The objects further include sign **218**, which includes a retroreflective strip **220**.

The LIDAR device (or a controller thereof) may avoid emitting light towards retroreflective materials. For example, in a first scan at or near to the detection plane **204**, the LIDAR device may detect clusters of high-intensity reflections (e.g., 95% or more of an emitted light pulse intensity). During a second scan, the LIDAR device may cause light emitters to scan a first portion of the environment and not scan a second portion. The second portion may include regions **222**, **224**, **226**, **228**, and **230**. By avoiding these areas, the LIDAR device reduces the likelihood of receiving high-intensity reflections from these regions. The LIDAR device may determine positions and times of light emissions that would illuminate these regions based on orientations and distances of received reflections relative to the detection plane **204**. Within other examples, a separate computing device (e.g., the system controller **102**) may perform these functions.

After determining which regions of the environment **200** to avoid illuminating, the LIDAR device selects light emitters for emitting light, and selects light emitters for not emitting light. In examples where only a single light emitter is used for emitting light (e.g., where an adjustable mirror is used in conjunction with a single light emitter to generate multiple light beams that are emitted into the environment) timing of the single light emitter or actions of a coordinating member (e.g., movement of an adjustable mirror) can be adjusted to emit light to some portions of an environment but not others. Further description of this is provided below with respect to FIGS. **3A-3D**.

FIG. **3A** illustrates a pulser circuit of a LIDAR device at a first time, according to an example embodiment. In particular, FIG. **3A** shows a pulser circuit **300** that includes a voltage source node **302** that can be connected to a voltage source (not depicted). For example, the voltage source may be an adjustable voltage source. The voltage source node **302** is connected to an inductor **304** at a first end. For example, the inductor may be a single inductor associated with the pulser circuit **104**. The inductor is connected to a first node **306** at a second end. The pulser circuit **300** further includes a second node **308**. A plurality of capacitors and corresponding light emitters (e.g., laser diodes) are connected in parallel between the first node **306** and the second node **308** through diodes **310**, **318**, **326**, and **334**, respectively.

Alternative portions of the environment **200** may be avoided by the LIDAR device as well. These may be aspects of the environment detected by the LIDAR device or other sensors (e.g., the sensors **112**). For example, a GPS device

may indicate a location of the LIDAR device. The location of the LIDAR device may be associated with known static objects that are highly reflective, and which may cause interference with reflections received from other objects in the environment. Based on this information, the LIDAR device may avoid emitting light towards the known static objects. In other examples where the LIDAR device is mounted to a vehicle, the LIDAR device may avoid emitting light towards a detected surface of the vehicle (e.g., a hood or trunk of the vehicle). Other examples are possible. The example depicted in FIG. **2** is referenced below for illustrative purposes.

In FIG. **3A**, four sets of capacitors and corresponding light emitters are depicted. However, it should be understood that more or fewer sets can be used. An anode end of a first diode **310** is connected to the first node **306** and a cathode end of the first diode **310** is connected to a first common node. An anode end of a first light emitter **312** (depicted as a light-emitting diode) is connected to the first common node and a cathode end of the first light emitter **312** is connected to the second node **308**. A first end of a first capacitor **314** is connected to the first common node and a second end of the first capacitor **314** is connected to ground. The first common node is connected to a shift register **344**. The shift register **344** may include a plurality of discharge-control transistors **350**, **352**, **354**, and **356**. In other examples, an output of the shift register **344** can be connected to gate of the discharge-control transistors **350**, **352**, **354**, and **356**. Discharge-control transistor **350** is associated with the first capacitor **314** at the first common node and is configured to selectively discharge the first capacitor **314** based on an output of the shift register **344**.

Within examples, the shift register **344** may be loaded with N bits of data (e.g., corresponding to N capacitors and N corresponding light emitters, or corresponding to as many as 2^N capacitors and 2^N corresponding light emitters depending on how the shift register **344** is configured) using a digital input to the shift register, and each bit of data may control a state of a discharge-control transistor. For example, a "1" may indicate that a discharge-control transistor is to be turned on and a "0" may indicate that a discharge-control transistor is to remain off, or vice versa. Further, as noted above, discharge-control transistors **350**, **352**, **354**, and **356** can be more generally referred to as "switches," and correspondingly, other switching devices could be used and operate similarly to discharge-control transistors **350**, **352**, **354**, and **356** as described herein. Within examples, the discharge-control transistors are controlled directly by a LIDAR controller, such as controller **116**. Other implementations are possible.

An anode end of a second diode **318** is connected to the first node **306** and a cathode end of the second diode **318** is connected to a second common node. An anode end of a second light emitter **320** (depicted as a photodiode) is connected to the second common node and a cathode end of the second light emitter **320** is connected to the second node **308**. A first end of a second capacitor **322** is connected to the second common node and a second end of the second capacitor **322** is connected to ground. The second common node is connected to the shift register **344**. The shift register **344** may include or be connected to a discharge-control transistor associated with the second capacitor **322** at the second common node. In particular, discharge-control transistor **352** is associated with the second capacitor **322** at the second common node and is configured to selectively discharge the second capacitor **322** based on an output of shift register **344**.

An anode end of a third diode **326** is connected to the first node **306** and a cathode end of the third diode **326** is connected to a third common node. An anode end of a third light emitter **328** (depicted as a light-emitting diode) is connected to the third common node and a cathode end of the third light emitter **328** is connected to the second node **308**. A first end of a third capacitor **330** is connected to the third common node and a second end of the third capacitor **330** is connected to ground. The third common node is connected to a shift register **344**. The shift register **344** may include or be connected to a discharge-control transistor associated with the third capacitor **330** at the third common node. In particular, discharge-control transistor **354** is associated with the third capacitor **330** at the third common node and is configured to selectively discharge the third capacitor **330** based on an output of shift register **344**.

An anode end of a fourth diode **334** is connected to the first node **306** and a cathode end of the fourth diode **334** is connected to a fourth common node. An anode end of a fourth light emitter **336** (depicted as a light-emitting diode) is connected to the fourth common node and a cathode end of the fourth light emitter **336** is connected to the second node **308**. A first end of a fourth capacitor **338** is connected to the fourth common node and a second end of the fourth capacitor **338** is connected to ground. The fourth common node is connected to a shift register **344**. The shift register **344** may include or be connected to a discharge-control transistor associated with the fourth capacitor **338** at the fourth common node. In particular, discharge-control transistor **356** is associated with the fourth capacitor **338** at the fourth common node and is configured to selectively discharge the fourth capacitor **338** based on an output of shift register **344**.

Within examples, cathode ends of the first light emitter **312**, second light emitter **320**, third light emitter **328**, and fourth light emitter **336** share a common cathode which forms the second node **308**. For example, a unitary device (such as a chip or printed circuit board, may include each of the light emitters). The second node **308** is connected to a pulse-control transistor **348** (depicted as a field effect transistor (FET), such as a MOSFET) at a drain end. The pulse-control transistor **348** is connected to ground at a source end. A gate of the pulse-control transistor **348** is controlled by a FET driver **346**. The FET driver may be configured to operationally bias the pulse-control transistor **348** based on control instructions such that the pulse-control transistor **348** promotes current flow or restricts current flow (e.g., such that little or no current flows from the second node **308** to ground). In other examples, an alternative to a transistor, such as a switch, can be used.

Also shown in FIG. 3A are a plurality of currents "I1" flowing through the respective diode and charging the respective capacitors or each set. This occurs at a first time at which the voltage source node **302** provides a voltage input to the inductor **304**, which in turn provides a voltage at the first node **306**. The FET driver **346** controls the pulse-control transistor **348** so that it restricts current flow from the second node **308** to ground. Similarly, the discharge-control transistors associated with shift register **344** restrict current flow at the first time. In turn, this causes the current I1 (which may vary slightly based on each diode and capacitor) to flow from the first node **306** to the capacitors, causing the capacitors to charge.

Voltage indicators **316**, **324**, **332**, and **340** are depicted in FIG. 3A for illustrative purposes, and correspond to capacitors **314**, **322**, **330**, and **338** respectively. The voltage indicators show a relative voltage level "Vcap" of each capaci-

tors at different times. At the first time, each capacitor has zero or minimal charge because the input voltage node **302** has just begun to provide a voltage.

FIG. 3B illustrates a pulser circuit of a LIDAR device at a second time, according to an example embodiment. In particular, FIG. 3B shows a different state of the pulser circuit **300** as shown in FIG. 3A and described above. The second time might be the end of a first period that spans the first time to the second time. The second time may also correspond to the beginning of a second period. The first period and the second period may be portions of a repeating pulse period of the pulser circuit **300**.

At the second time, each capacitor has been charged, as shown by voltage indicators **316**, **324**, **332**, and **340**. Though these indicate a maximum Vcap has been reached, depending on a voltage level at the first node **306** and a time taken to charge the capacitors, a different voltage may be reached. For example, in a default mode of operation, an adjustable voltage source connected to the voltage source node **302** may be controlled to apply a voltage V1 to the inductor **304**, which causes each of the capacitors to charge up to a voltage of Vcap1 (e.g., Vcap1 could be about 2×V1). When the capacitors discharge through their respective laser diodes, as described further below, the emitted light pulses may have a first peak power level. However, for relatively short periods of time (e.g., based on thermal constraints), the adjustable voltage source may be controlled to apply a voltage V2 to the inductor in which V2>V1. This causes the capacitors to charge up to a higher voltage, Vcap2 (e.g., Vcap2 could be about 2×V2). Thus, when the capacitors discharge through their respective laser diodes, the emitted light pulses may have a second, higher peak power level. In this manner, the pulser circuit **300** can be controlled to emit light from the light emitters at different intensities, which can allow for more nuanced control of the LIDAR device. For example, increased light intensities may be used where the environment is relatively bright (e.g., based on other light sources in the environment), while lower light intensities can be used in low-light conditions (e.g., at night) to conserve energy usage.

In additional or alternative examples, controlling the voltage levels of the capacitors may alternatively or additionally involve applying a voltage for a period of time associated with charging the capacitor. For example, a desired power level of a light pulse can be determined that is associated with a charge level of the capacitors. The capacitors may be charged for a period of time (e.g., based on a known capacitance of the capacitors and the applied voltage) associated with the power level. Because the capacitance of each capacitor is predetermined and a voltage output at the first node **306** is known (e.g., controlled to be at a particular voltage level), charging characteristics of each capacitor can be used to accurately set the charge level of the capacitors. For example, a time constant can be determined and used to calculate a charging time for the capacitors. In this manner, a power level of each light pulse can be precisely controlled by setting the charging period for the capacitors. Additionally or alternatively, each charged capacitor can be discharged by a predetermined amount prior to the emission period to achieve a desired voltage level and thereby control a power level of each light pulse.

Turning back to FIG. 3B, a plurality of currents "I2" are shown that correspond to capacitors **314** and **330**. This is caused using discharge-control transistors **350** and **354** corresponding to capacitors **314** and **330**, as shown in shift register **344** of FIG. 3B. As noted above, in other implementations, these transistors may exist separately from the

shift register **344** and operate based on outputs of the shift register. Thus, at the second time, all of the capacitors are charged and capacitors **314** and **330** have been selected for discharging. Further, because the FET driver **346** controls the pulse-control transistor **348** so that it restricts current flow from the second node **308** to ground, zero or minimal current flows through the light emitters at the second time.

Discharging capacitors **314** and **330** corresponds to not emitting light (or emitting a relatively low level of light) from light emitters **312** and **328** respectively. Using FIG. **2** as a reference scenario for illustrative purposes, based on a status of a LIDAR device that includes the light emitters (e.g., a location of the LIDAR device), and based on regions of the environment that the LIDAR device is avoiding (e.g., regions **228** and **230** corresponding to retroreflector **216** and retroreflective strip **220**), some light detectors might be “turned off” for a given pulse period to avoid emitting light towards the regions of the environment that the LIDAR device is avoiding. For example, the LIDAR device (or another device, such as the system controller **102**) may determine which light emitters are scheduled to emit light towards the avoided regions, and select corresponding capacitors for discharging so that those light emitters do not emit light. In the present example, this includes discharging capacitors **314** and **330** so that light emitters **312** and **328** do not emit light so that the LIDAR device does not illuminate regions **228** and **230**. As referred to below with respect to FIG. **4**, this process may involve determining a portion of an environment to illuminate using the light emitters and a remaining portion. The remaining portion may correspond to regions that the LIDAR device avoids illuminating with one or more light emitters.

FIG. **3C** illustrates a pulser circuit of a LIDAR device at a third time, according to an example embodiment. In particular, FIG. **3C** shows a different state of the pulser circuit **300** as shown in FIGS. **3A** and **3B** and described above. The third time might be the end of a second period that spans the second time to the third time. The third time may also correspond to the beginning of a third period. The second period and the third period may be portions of a repeating pulse period of the pulser circuit **300**.

As shown by voltage indicators **316** and **332** corresponding to capacitors **314** and **330** respectively have zero or minimal voltage as a result of being discharged during the second period. Also shown are a plurality of currents “I3” from capacitors **322** and **338** to the second node **308** and current “I4” from the second node to ground. At the third time, the FET driver **346** controls the pulse-control transistor **348** so that it promotes current flow from the second node **308** to ground, the currents I3 and I4 are permitted to flow across light emitters **312** and **336** from corresponding capacitors **322** and **338**, thereby causing light emitters **312** and **336** to emit light. Returning again to FIG. **2** for illustrative purposes, light emitters **312** and **336** may be directed to portions of the environment other than regions **222**, **224**, **226**, **228**, and **230**, and thus correspond to the portion of the environment illuminated using the light emitters.

FIG. **3D** illustrates a pulser circuit of a LIDAR device at a fourth time, according to an example embodiment. In particular, FIG. **3D** shows a different state of the pulser circuit **300** as shown in FIGS. **3A**, **3B**, and **3C** and described above. The fourth time might be the end of a third period that spans the third time to the fourth time. The third period may be a portion of a repeating pulse period of the pulser circuit **300**. In other examples, a latent period may extend from the fourth time to a beginning time of another pulse period,

depending on scanning frequencies of the LIDAR device. As shown in voltage indicators **316**, **324**, **332**, and **338**, after the third time, each of the capacitors is discharged and the pulser circuit **300** can begin another pulse period during which different light emitters might be selection for emitting light or not emitting light depending on a status of the LIDAR device and/or the surrounding environment.

III. Example Methods

FIG. **4** is a block diagram of a method, according to an example embodiment. In particular, FIG. **4** depicts a method **400** for use in selectively emitting light from a plurality of light emitters. Method **400** may be implemented in accordance with system **100**, the pulser circuit **300** or the description thereof. For example, aspects of the functions of method **400** may be performed by system controller **102**, controller **116**, or by logical circuitry configured to implement the functions described above with respect to FIGS. **1A**, **1B**, **2**, **3A**, **3B**, **3C**, and **3D**.

At block **402**, method **400** includes, during a first period (e.g., between the first time and the second time shown in FIGS. **3A** and **3B** respectively), (i) using a pulse-control switch to restrict current flow through a plurality of light emitters, and (ii) charging a plurality of capacitors via a first node. This may be performed in accordance with FIGS. **3A**, **3B**, and corresponding description thereof.

At block **404**, method **400** includes, during a second period (e.g., between the second time and the third time shown in FIGS. **3B** and **3C** respectively), using one or more discharge-control switches to allow current flow that discharges one or more corresponding capacitors of the plurality of capacitors. This may be performed in accordance with FIGS. **3B**, **3C**, and corresponding description thereof.

At block **406**, method **400** includes, during a third period (e.g., between the third time and the fourth time shown in FIGS. **3C** and **3D** respectively), using the pulse-control switch to allow current flow and thereby discharge one or more undischarged capacitors of the plurality of capacitors through one or more corresponding light emitters of the plurality of light emitters, thereby causing the one or more corresponding light emitters to emit respective pulses of light. This may be performed in accordance with FIGS. **3B**, **3C**, and corresponding description thereof.

Within examples, method **400** further includes determining a portion of an environment to illuminate using the light emitters and a remaining portion. For example, in a default state of a LIDAR device, this may include an entire field of view associated with a range of motion of light emitters in the LIDAR device. In other states, such as that depicted in FIG. **2**, this may involve a majority of the environment minus some regions that the LIDAR device avoids. In these examples, method **400** includes determining one or more light emitters corresponding to the remaining portion of the environment at an emission time (e.g., light emitters **312** and **332**). In such examples block **404** involves using the one or more discharge-control switches to allow current flow and thereby discharge the one or more light emitters corresponding to the remaining portion of the environment. In this manner, method **400** allows illuminating select portions of the environment. As an example of these embodiments, determining the portion of an environment to illuminate using the light emitters and the remaining portion includes emitting light using the light emitters during a first scan of the environment (e.g., as described above with respect to FIG. **2**), receiving reflected portions of the emitted light corresponding to the first scan, and determining, based on the received reflected portions of emitted light, not to emit light towards the remaining portion of the environment

during a second scan of the environment. For example, this may correspond to not emitting light towards regions **222**, **224**, **226**, **228**, and **230** depicted in FIG. 2. In still further examples, method **400** may include identifying, based on the received reflected portions of emitted light, a type of object in the environment (e.g., a retroreflector). In such examples determining not to emit light towards the remaining portion of the environment during the second scan of the environment includes determining not to emit light towards the type of object in the environment. For example, the region may be determined based on identifying a portion of a field of view of the LIDAR device corresponding to the retroreflectors in the first scan, determining a buffer region (e.g., 6 inches) around the identified retroreflectors, and not emitting light within portion of the fields of view and/or the buffer region.

Within examples in which the one or more discharge-control switches correspond to outputs from a shift register, block **404** may include using the one or more discharge-control switches to allow current flow and thereby discharge one or more of the plurality of capacitors, comprises using a plurality of bits input into the shift register to designate which of the plurality of capacitors is discharged during the second period and which of the plurality of capacitors are undischarged during the second period.

Within examples in which the method is implemented using a LIDAR device (e.g., the LIDAR device **110**), method **400** can further include determining an expected change in pose of the LIDAR device from a first scan of the LIDAR device to a second scan of the LIDAR device. For example, if the LIDAR is coupled to a vehicle, a controller of the vehicle (e.g., system controller **102**) may determine a velocity of the vehicle and determine where the LIDAR device will be during the second scan. In such examples, block **404** further includes selecting the one or more of the plurality of capacitors for discharging based on the expected change in pose of the LIDAR device from the first scan of the LIDAR device to the second scan of the LIDAR device. For example, the expected pose may influence which light emitter is scheduled to illuminate a region that the LIDAR device should avoid illuminating.

Within examples, method **400** may be performed multiple times in succession, with different light emitters being selected for emitting light and not emitting light in different iterations. In this manner the systems and methods described herein may adapt to changing conditions in the environment or different instructions received, for example, from the system controller **102**. For example, the first period, the second period, and the third period are included within a first pulse period of a plurality of repeating pulse periods associated with the plurality of light emitters. And, during a second pulse period of the plurality of pulse periods the first, second, and third periods may be performed again using different light emitters. Namely, during the first period of the second pulse period, method **400** includes (i) using the pulse-control switch to restrict current flow through a plurality of light emitters, and (ii) charging the plurality of capacitors via a first node. Further, during the second period of the second pulse period, method **400** includes using the one or more discharge-control switches to allow current flow and thereby discharge one or more different capacitors of the plurality of capacitors. Additionally, during the third period of the second pulse period, method **400** includes using the pulse-control switch to allow current flow and thereby discharge one or more different undischarged capacitors

through one or more different light emitters causing the one or more different light emitters to emit respective pulses of light.

Though particular embodiments described herein show certain ways of charging and discharging capacitors within pulse periods as a way of selecting particular light emitters for emitting light or not emitting light, different ways of achieving this are possible. For example, different types of transistors or diodes can be used, or switches or other devices capable of imposing discrete states on a pulser circuit can be used in various implementations and within the contemplated scope of this disclosure. Further, though operations described herein refer to computing devices such as system controller **102**, and controller **116**, it should be understood that the functions described herein may be performed by either of these computing devices, both computing devices, or neither computing device. For example, logical circuitry and periodic timing circuits can be used to perform aspects of this disclosure by default or automatically. Further, though embodiments are described with a certain number of light emitters, it should be understood that substantially more light emitters (or, in other examples, fewer light emitters, such as one light emitter) may be included in a single pulser circuit depending on contexts of the system (e.g., some LIDAR devices can include a single light emitter, while others may include several). In other examples, several pulser circuits may run concurrently to drive all light emitters in a LIDAR device. Other examples are possible.

The particular arrangements shown in the Figures should not be viewed as limiting. It should be understood that other embodiments may include more or less of each element shown in a given Figure. Further, some of the illustrated elements may be combined or omitted. Yet further, an illustrative embodiment may include elements that are not illustrated in the Figures.

A step or block that represents a processing of information can correspond to circuitry that can be configured to perform the specific logical functions of a herein-described method or technique. Alternatively or additionally, a step or block that represents a processing of information can correspond to a module, a segment, a physical computer (e.g., a field programmable gate array (FPGA) or application-specific integrated circuit (ASIC)), or a portion of program code (including related data). The program code can include one or more instructions executable by a processor for implementing specific logical functions or actions in the method or technique. The program code and/or related data can be stored on any type of computer readable medium such as a storage device including a disk, hard drive, or other storage medium.

The computer readable medium can also include non-transitory computer readable media such as computer-readable media that store data for short periods of time like register memory, processor cache, and random access memory (RAM). The computer readable media can also include non-transitory computer readable media that store program code and/or data for longer periods of time. Thus, the computer readable media may include secondary or persistent long term storage, like read only memory (ROM), optical or magnetic disks, compact-disc read only memory (CD-ROM), for example. The computer readable media can also be any other volatile or non-volatile storage systems. A computer readable medium can be considered a computer readable storage medium, for example, or a tangible storage device.

15

While various examples and embodiments have been disclosed, other examples and embodiments will be apparent to those skilled in the art. The various disclosed examples and embodiments are for purposes of illustration and are not intended to be limiting, with the true scope being indicated by the following claims.

What is claimed is:

1. A circuit comprising:

a plurality of light emitters connected between a first node and a second node;

a plurality of capacitors, wherein each capacitor in the plurality of capacitors corresponds to a respective light emitter in the plurality of light emitters;

a plurality of discharge-control switches, wherein each discharge-control switch corresponds to a respective capacitor in the plurality of capacitors; and

a pulse-control switch connected to the plurality of light emitters,

wherein, during a first period, the pulse-control switch restricts current flow and each capacitor in the plurality of capacitors is charged via the first node,

wherein, during a second period, one or more of the plurality of discharge-control switches allows current flow that discharges one or more corresponding capacitors of the plurality of capacitors, and

wherein, during a third period, the pulse-control switch allows current flow that discharges one or more undischarged capacitors of the plurality of capacitors through one or more corresponding light emitters of the plurality of light emitters, thereby causing the one or more corresponding light emitters to emit respective pulses of light.

2. The circuit of claim **1**, wherein the pulse-control switch comprises a field-effect transistor.

3. The circuit of claim **1**, wherein the plurality of light emitters comprises a plurality of laser diodes sharing a common cathode, and wherein the common cathode is connected to the pulse-control switch at the second node.

4. The circuit of claim **1**, further comprising a shift register configured to select individual capacitors from the plurality of capacitors, via corresponding discharge-control switches in the plurality of discharge-control switches, for discharging.

5. The circuit of claim **4**, wherein the shift register is configured to receive a digital input comprising a plurality of bits, wherein each bit in the plurality of bits indicates whether a corresponding capacitor in the plurality of capacitors is discharged or undischarged during the second period.

6. The circuit of claim **1**, further comprising a plurality of diodes connected between the first node and the plurality of capacitors, wherein each capacitor of the plurality of capacitors is charged via a corresponding diode of the plurality of diodes.

7. The circuit of claim **1**, further comprising a driver circuit connected to the pulse-control switch and configured to bias the pulse-control switch to allow current flow during the third period.

8. The circuit of claim **1**, wherein the first period, the second period, and the third period, occur within a repeating pulse period associated with the plurality of light emitters.

9. The circuit of claim **1**, further comprising a single inductor connected to the first node, wherein the single inductor is configured to charge the plurality of capacitors during the first period.

10. The circuit of claim **1**, further comprising an adjustable voltage source connected to the first node, wherein the plurality of capacitors are charged during the first period in

16

accordance with a voltage level of the adjustable voltage source, and wherein the respective pulses of light emitted during the third period have a peak power level that is based on the voltage level.

11. A method comprising:

during a first period,

(i) using a pulse-control switch to restrict current flow through a plurality of light emitters, and

(ii) charging a plurality of capacitors via a first node;

during a second period,

using one or more discharge-control switches to allow current flow that discharges one or more corresponding capacitors of the plurality of capacitors; and

during a third period,

using the pulse-control switch to allow current flow and thereby discharge one or more undischarged capacitors of the plurality of capacitors through one or more corresponding light emitters of the plurality of light emitters, thereby causing the one or more corresponding light emitters to emit respective pulses of light.

12. The method of claim **11**, further comprising:

determining a portion of an environment to illuminate using the light emitters and a remaining portion; and

determining one or more light emitters corresponding to the remaining portion of the environment at an emission time,

wherein using the one or more discharge-control switches to allow current flow and thereby discharge the one or more of the plurality of capacitors comprises using the one or more discharge-control switches to allow current flow and thereby discharge the one or more light emitters corresponding to the remaining portion of the environment.

13. The method of claim **12**, wherein determining the portion of an environment to illuminate using the light emitters and the remaining portion comprises:

emitting light using the light emitters during a first scan of the environment;

receiving reflected portions of the emitted light corresponding to the first scan;

determining, based on the received reflected portions of emitted light, not to emit light towards the remaining portion of the environment during a second scan of the environment.

14. The method of claim **13**, further comprising:

identifying, based on the received reflected portions of emitted light, a type of object in the environment,

wherein determining not to emit light towards the remaining portion of the environment during a second scan of the environment comprises determining not to emit light towards the type of object in the environment.

15. The method of claim **14**, wherein the type of object is a retroreflector.

16. The method of claim **11**, wherein the one or more discharge-control switches correspond to outputs from a shift register, and

wherein using the one or more discharge-control switches to allow current flow and thereby discharge one or more of the plurality of capacitors, comprises using a plurality of bits input into the shift register to designate which of the plurality of capacitors is discharged during the second period and which of the plurality of capacitors are undischarged during the second period.

17. The method of claim **11**, wherein the method is implemented using a LIDAR device, the method further comprising:

17

determining an expected change in pose of the LIDAR device from a first scan of the LIDAR device to a second scan of the LIDAR device,

wherein using the one or more discharge-control switches to allow current flow and thereby discharge one or more of the plurality of capacitors, comprises:

selecting the one or more of the plurality of capacitors for discharging based on the expected change in pose of the LIDAR device from the first scan of the LIDAR device to the second scan of the LIDAR device.

18. The method of claim **11**, wherein the first period, the second period, and the third period are comprised within a first pulse period of a plurality of repeating pulse periods associated with the plurality of light emitters, the method further comprising:

during a second pulse period of the plurality of pulse periods;

during the first period of the second pulse period,

(i) using the pulse-control switch to restrict current flow through a plurality of light emitters, and

(ii) charging the plurality of capacitors via a first node;

during the second period of the second pulse period,

using the one or more discharge-control switches to allow current flow that discharges one or more different capacitors of the plurality of capacitors; and

during the third period of the second pulse period,

using the pulse-control switch to allow current flow and thereby discharge one or more different undischarged capacitors through one or more different light emitters, thereby causing the one or more different light emitters to emit respective pulses of light.

19. A non-transitory computer readable medium having instructions stored thereon that when executed by a processor cause performance of a set of functions, wherein the set of functions comprises:

18

during a first period,

(i) using a pulse-control switch to restrict current flow through a plurality of light emitters, and

(ii) charging a plurality of capacitors via a first node; during a second period,

using one or more discharge-control switches to allow current flow that discharges one or more corresponding capacitors of the plurality of capacitors; and

during a third period,

using the pulse-control switch to allow current flow and thereby discharge one or more undischarged capacitors of the plurality of capacitors through one or more corresponding light emitters of the plurality of light emitters, thereby causing the one or more corresponding light emitters to emit respective pulses of light.

20. The non-transitory computer readable medium of claim **19**, wherein the set of functions further comprise:

emitting light using the light emitters during a first scan of an environment;

receiving reflected portions of the emitted light corresponding to the first scan;

determining, based on the received reflected portions of emitted light, a portion of an environment to illuminate using the light emitters and a remaining portion; and

determining one or more light emitters corresponding to the remaining portion of the environment at an emission time,

wherein using the one or more discharge-control switches to allow current flow and thereby discharge the one or more of the plurality of capacitors comprises using the one or more discharge-control switches to allow current flow that discharges the one or more light emitters corresponding to the remaining portion of the environment.

* * * * *