

US010775217B1

(12) **United States Patent**
Higashi et al.

(10) **Patent No.:** **US 10,775,217 B1**
(45) **Date of Patent:** **Sep. 15, 2020**

(54) **THERMOPHILE-BASED FLOW SENSING DEVICE**

6,035,711 A * 3/2000 Huijsing G01F 1/6845
73/202.5

(71) Applicant: **Honeywell International Inc.**, Morris Plains, NJ (US)

6,238,085 B1 5/2001 Higashi et al.
6,550,324 B1 * 4/2003 Mayer G01F 1/6986
73/204.14

(72) Inventors: **Robert Higashi**, Shorewood, MN (US);
Scott Edward Beck, Murphy, TX (US);
Yong-Fa Wang, Frisco, TX (US); **Ian Bentley**, New Ipswich, NH (US); **Bill Hoover**, Plain City, OH (US)

6,763,710 B2 7/2004 Mayer et al.
7,278,309 B2 10/2007 Dmytriw et al.
7,490,511 B2 2/2009 Mayer et al.
8,011,240 B2 9/2011 von Waldkirch et al.
8,356,514 B2 1/2013 Wang et al.
8,809,980 B2 * 8/2014 Nakatani G01J 5/02
250/338.1

(73) Assignee: **Honeywell International Inc.**, Morris Plains, NJ (US)

9,664,545 B2 5/2017 Knittel et al.
10,094,691 B2 * 10/2018 Figi G01F 1/6888
2016/0161951 A1 6/2016 Hornung et al.

(*) Notice: Subject to any disclaimer, the term of this patent is extended or adjusted under 35 U.S.C. 154(b) by 0 days.

OTHER PUBLICATIONS

Wrbanek, John D. et al., "Development of Thin Film Ceramic Thermocouples for High Temperature Environments," NASA/TM-2004-213211, AIAA-2004-3549, (2004).

(21) Appl. No.: **16/389,647**

(22) Filed: **Apr. 19, 2019**

* cited by examiner

(51) **Int. Cl.**

G01F 1/68 (2006.01)
G01F 1/688 (2006.01)
H01L 27/16 (2006.01)
H01L 35/14 (2006.01)
G01F 1/684 (2006.01)

Primary Examiner — Jewel V Downtin

(74) *Attorney, Agent, or Firm* — Alston & Bird LLP

(52) **U.S. Cl.**

CPC **G01F 1/6888** (2013.01); **G01F 1/6847** (2013.01); **H01L 27/16** (2013.01); **H01L 35/14** (2013.01)

(57) **ABSTRACT**

Example systems, apparatuses, and methods are disclosed sensing a flow of fluid using a thermopile-based flow sensing device. An example apparatus includes a flow sensing device comprising a heating structure having a centerline. The flow sensing device may further comprise a thermopile. At least a portion of the thermopile may be disposed over the heating structure. The thermopile may comprise a first thermocouple having a first thermocouple junction disposed upstream of the centerline of the heating structure. The thermopile may further comprise a second thermocouple having a second thermocouple junction disposed downstream of the centerline of the heating structure.

(58) **Field of Classification Search**

CPC G01F 1/68
See application file for complete search history.

(56) **References Cited**

U.S. PATENT DOCUMENTS

4,651,564 A * 3/1987 Johnson G01F 1/6845
219/538
5,393,351 A * 2/1995 Kinard H01L 35/08
136/200

20 Claims, 33 Drawing Sheets

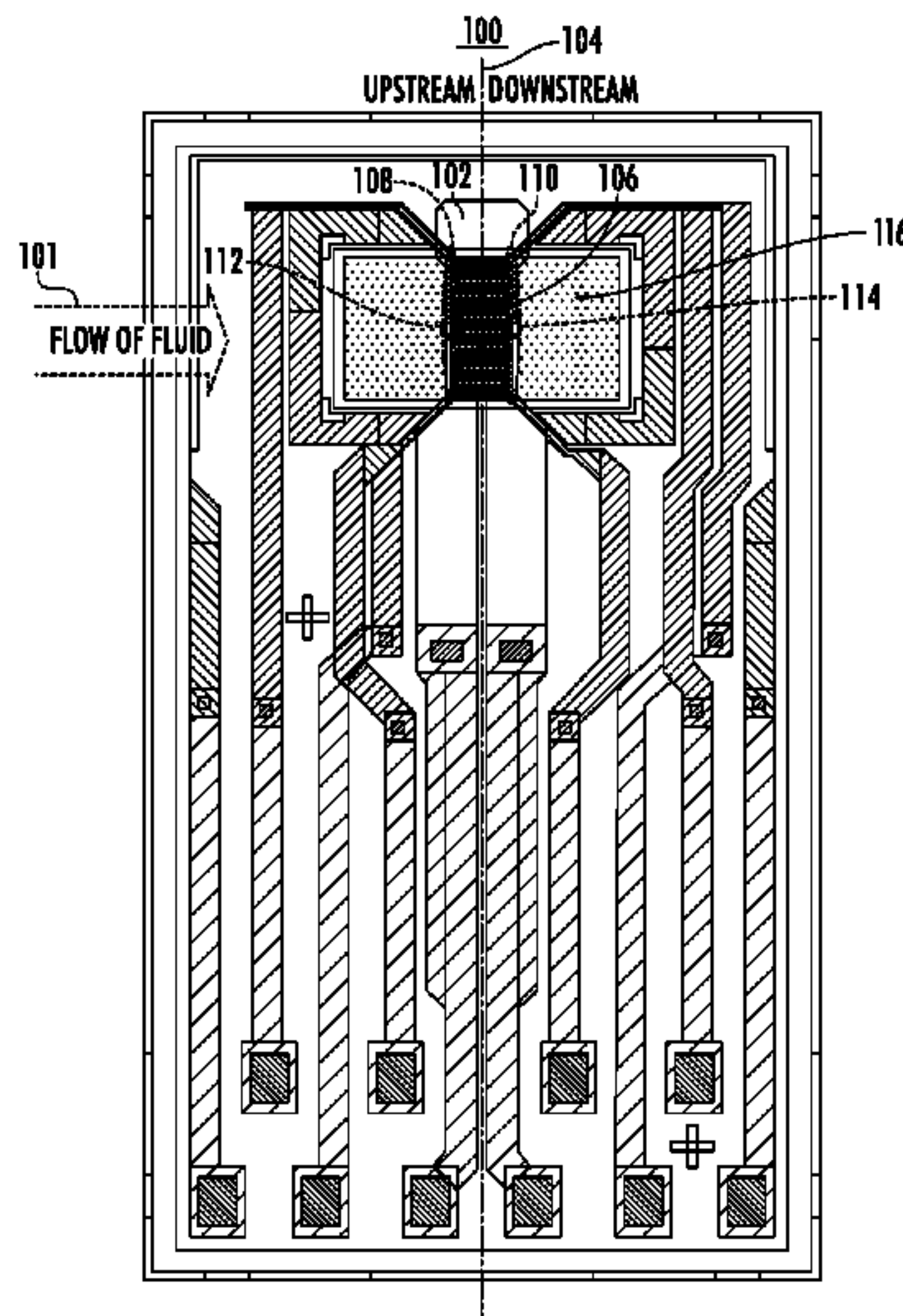

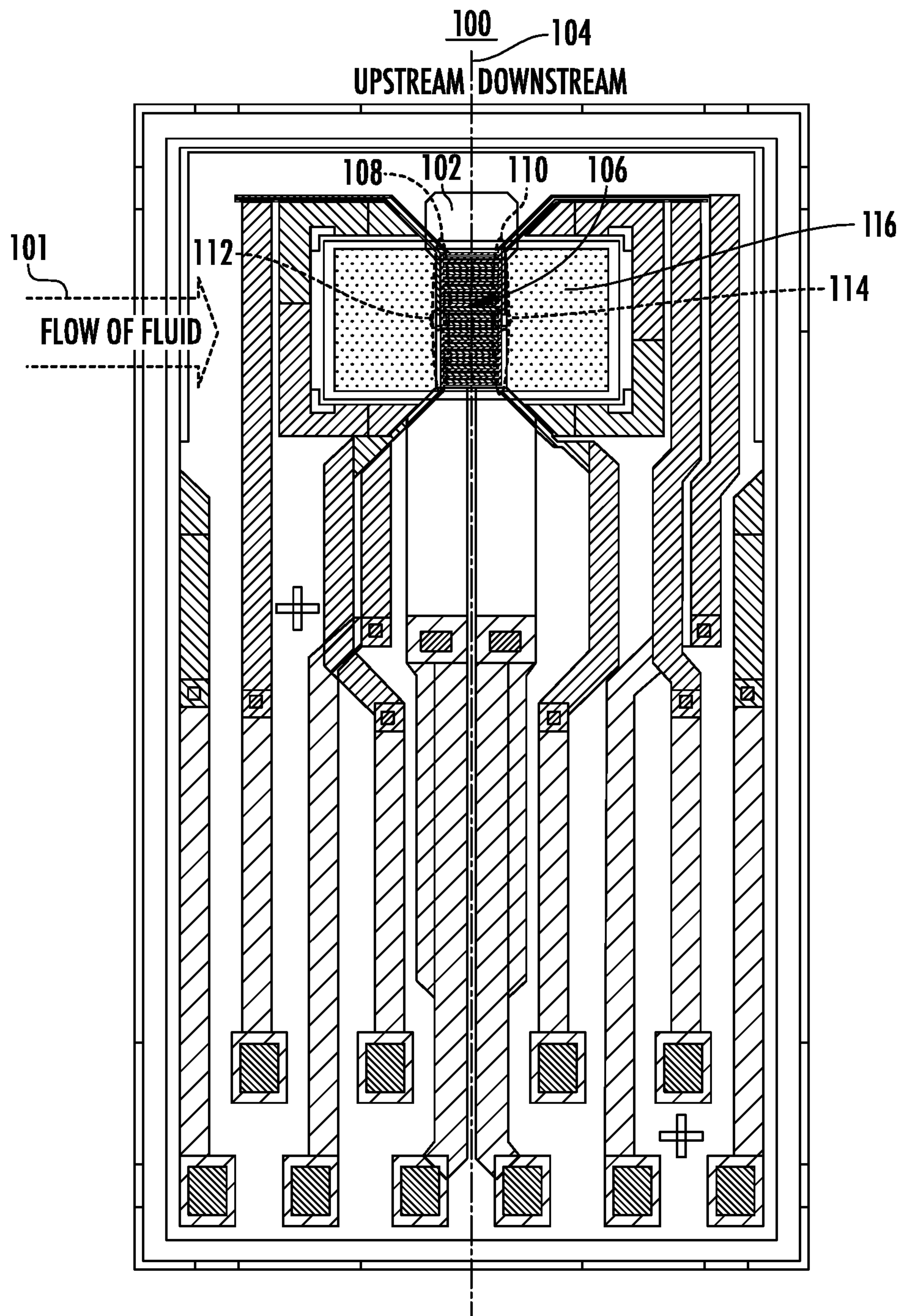

FIG. 1

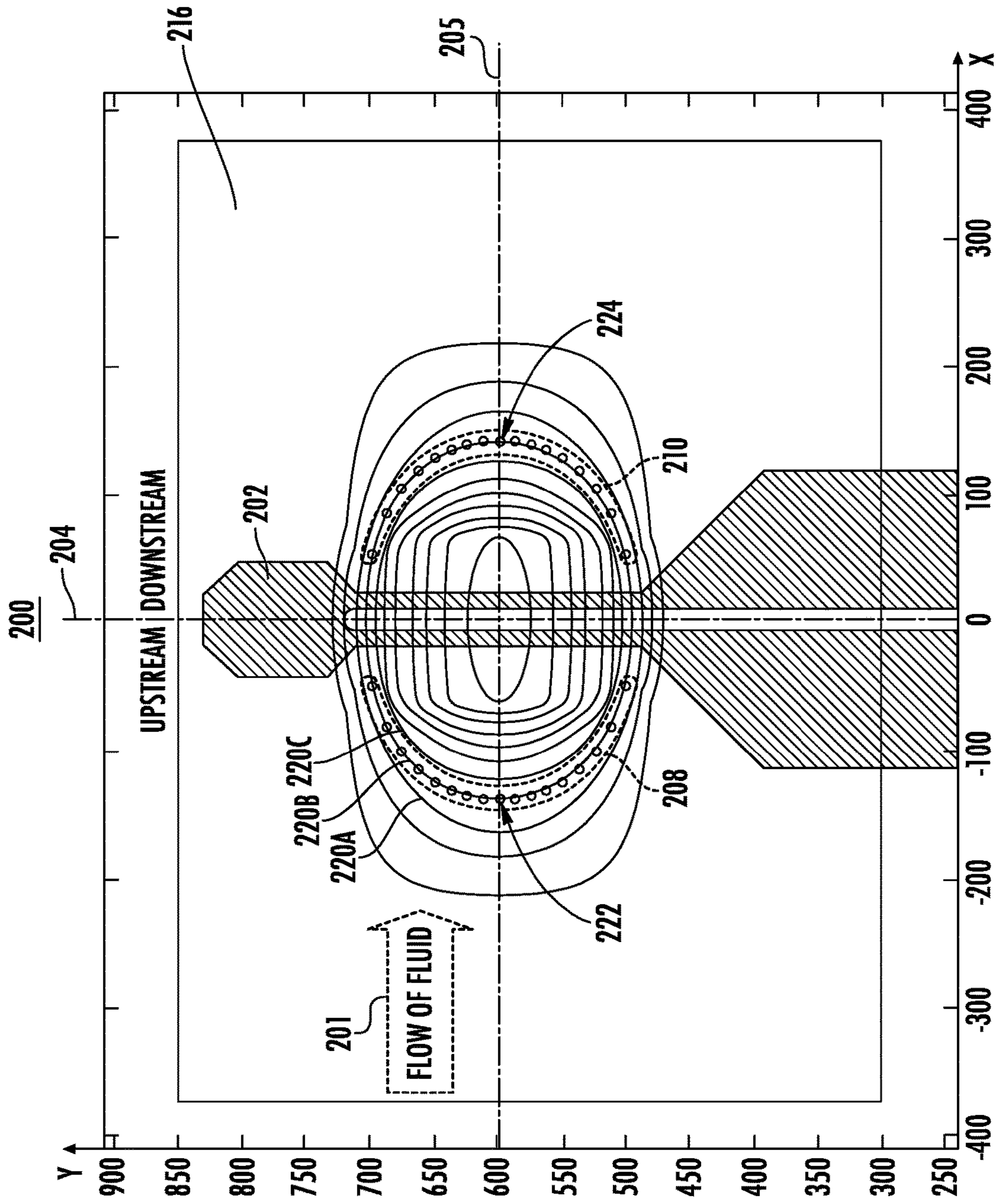

FIG. 2A

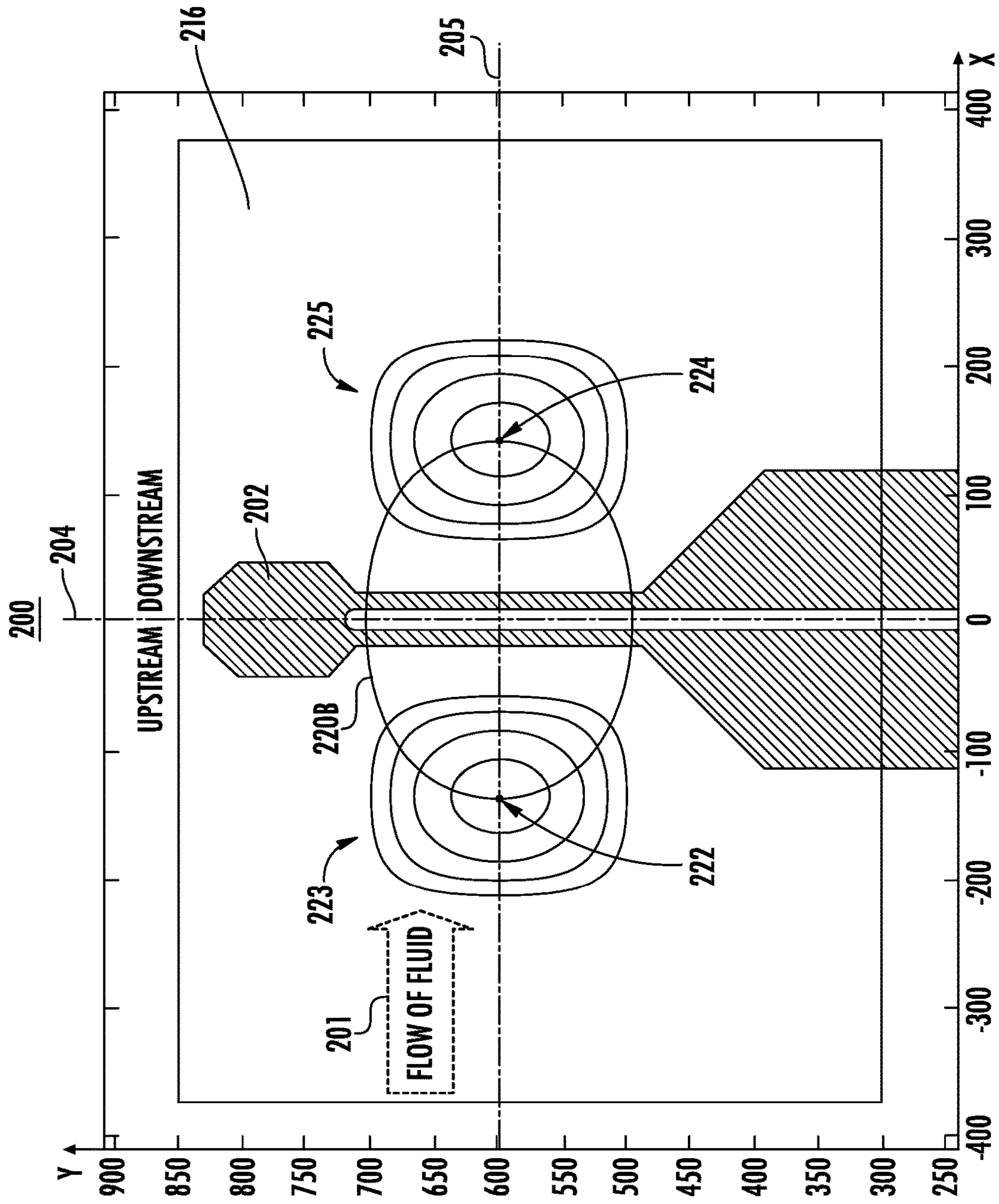

FIG. 2B

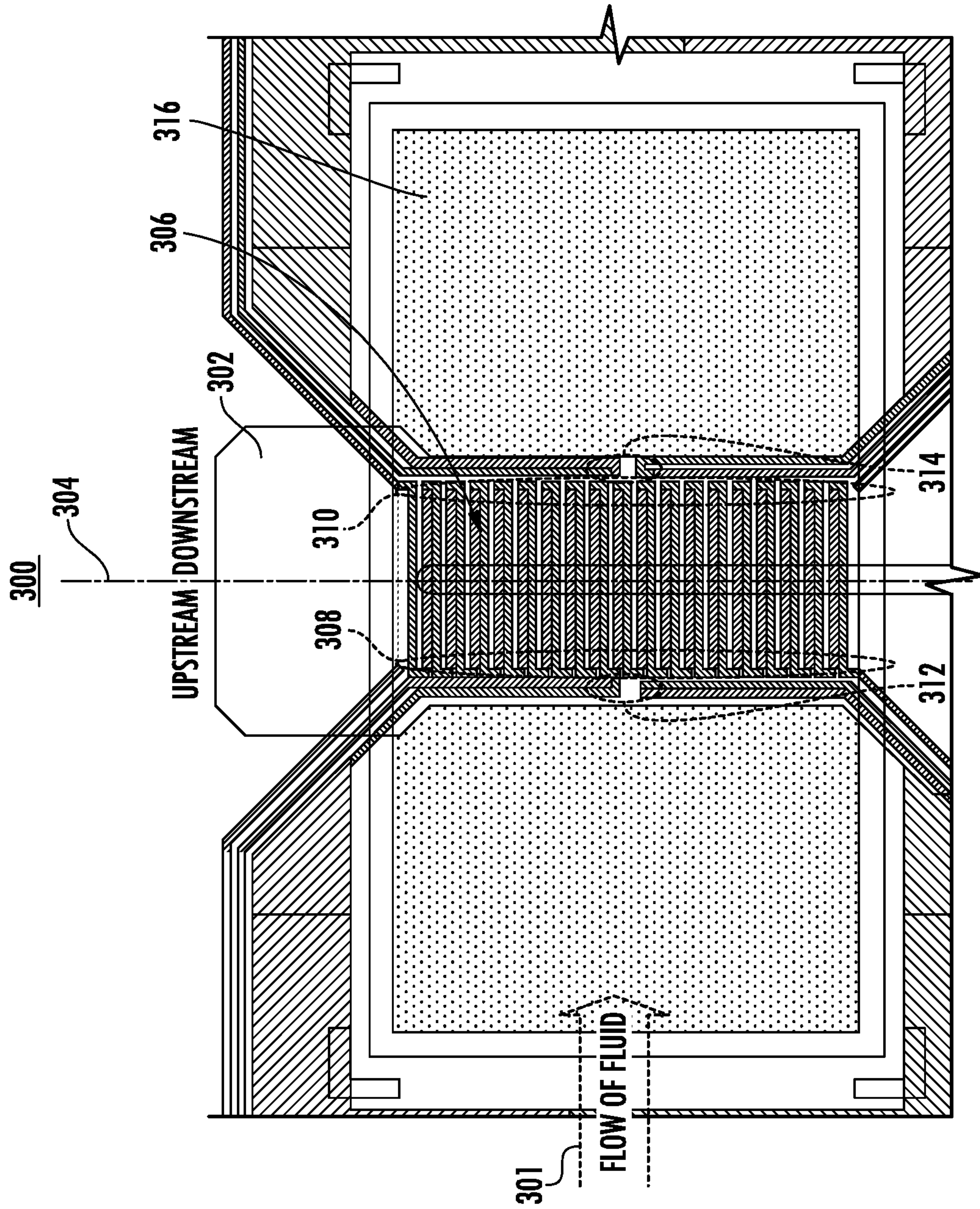

FIG. 3

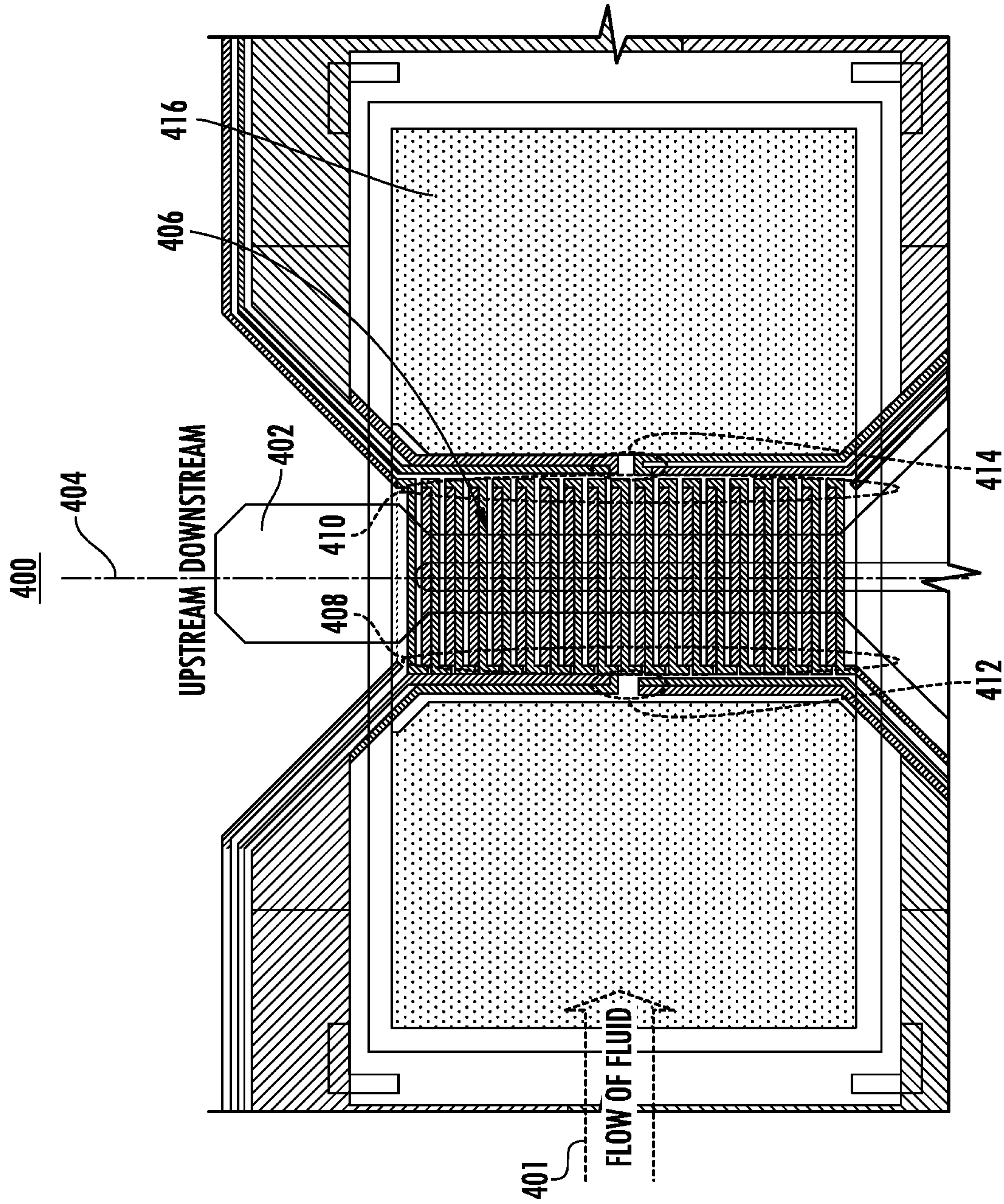

FIG. 4

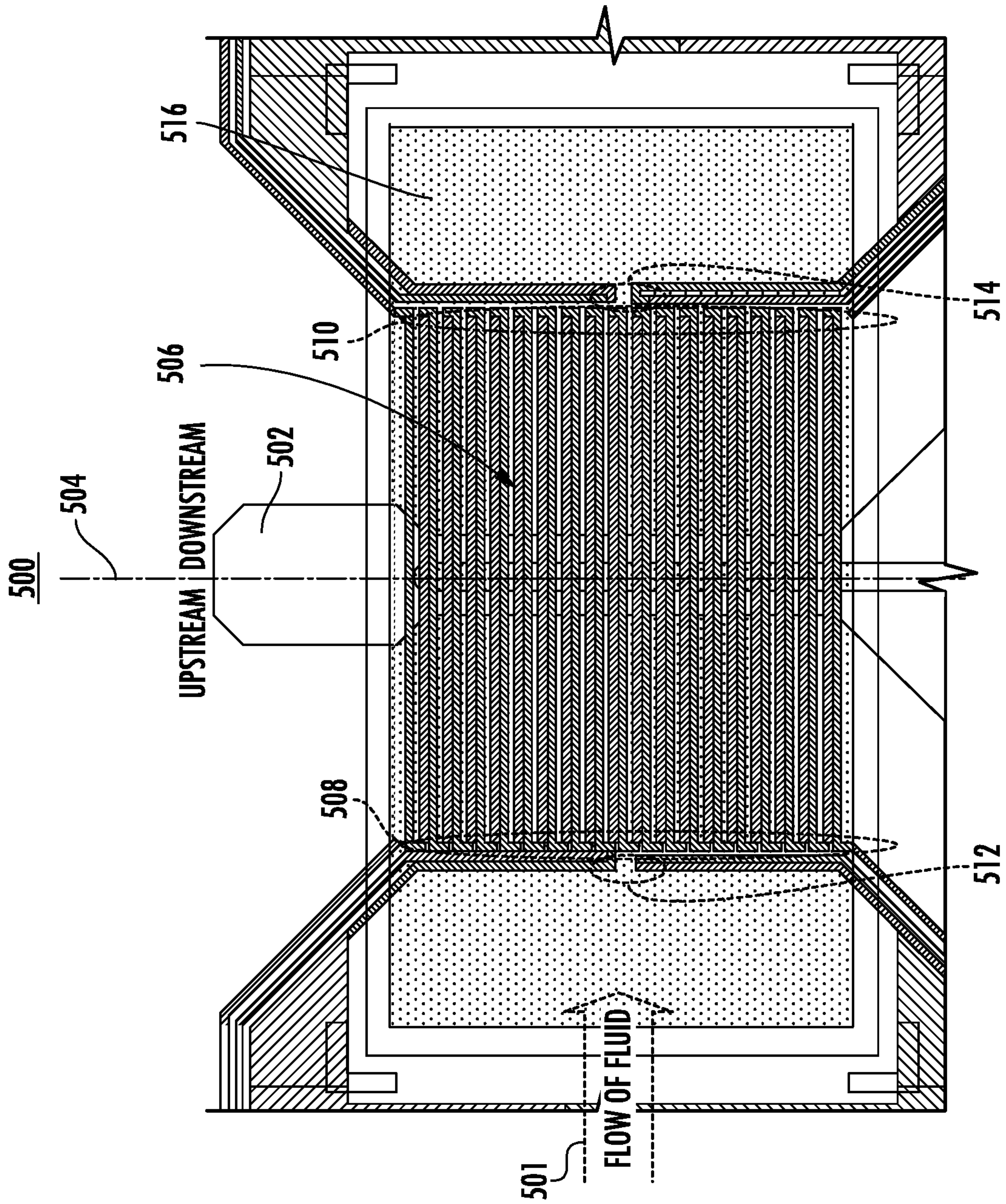

FIG. 5

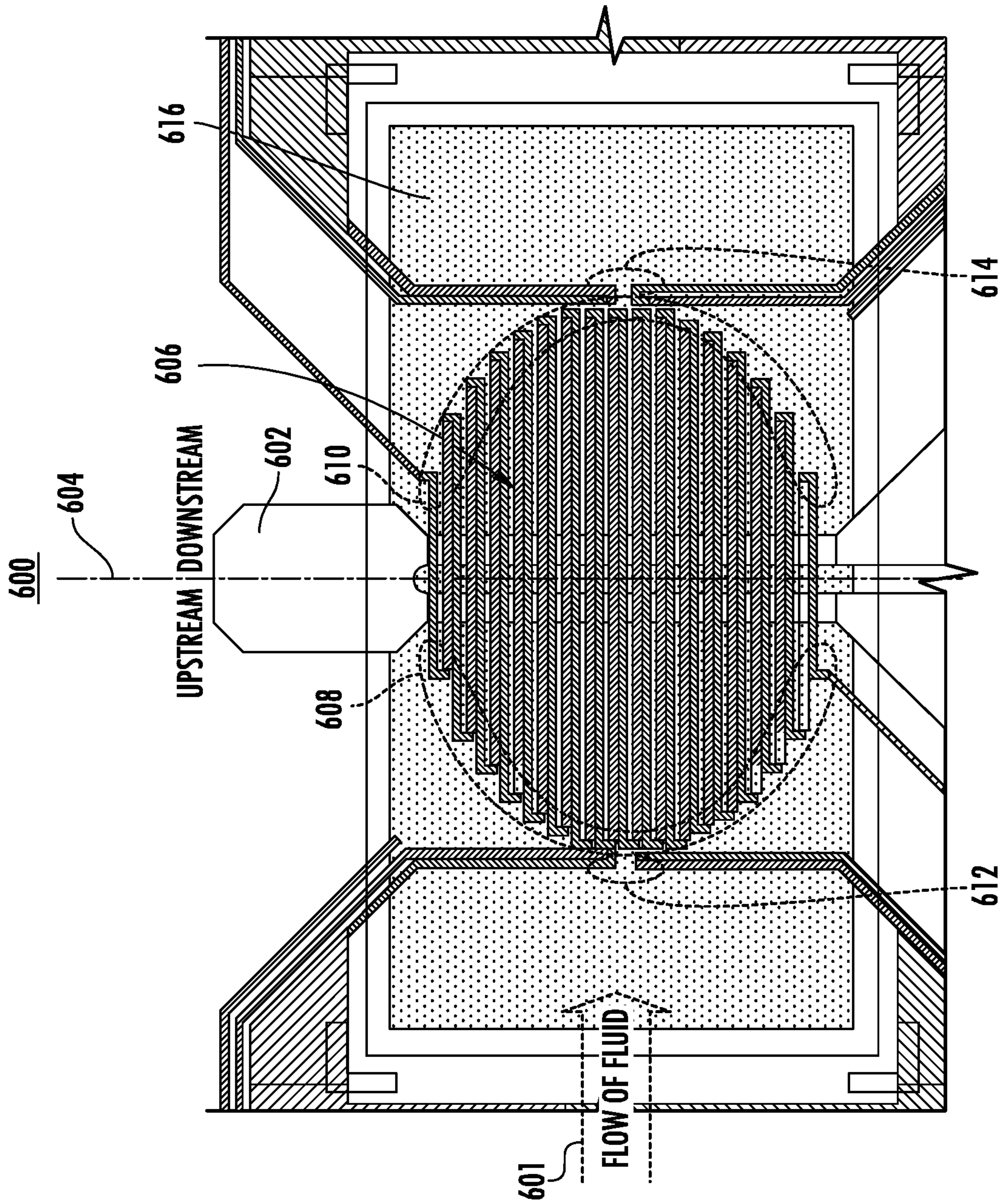

FIG. 6

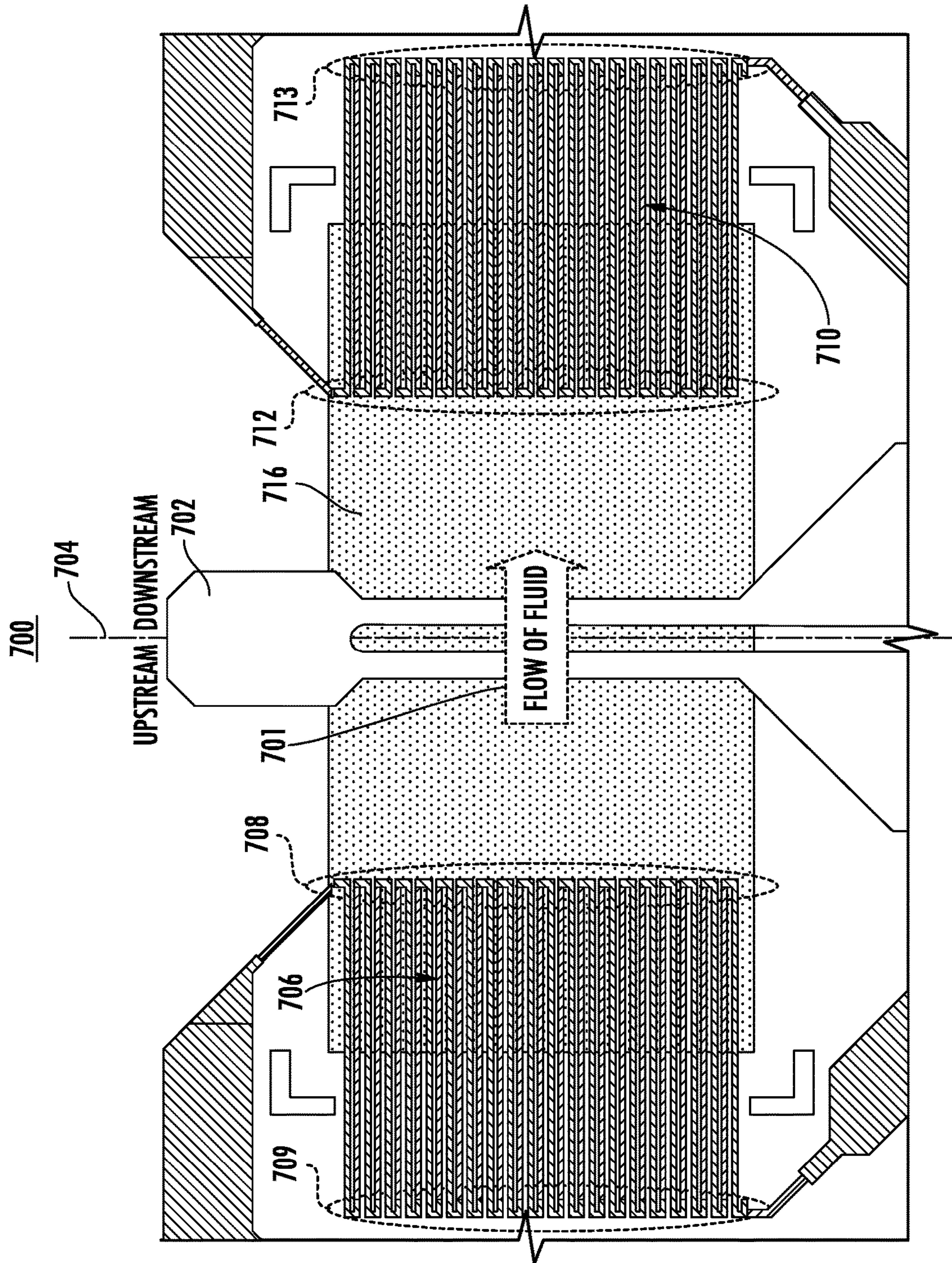

FIG. 7

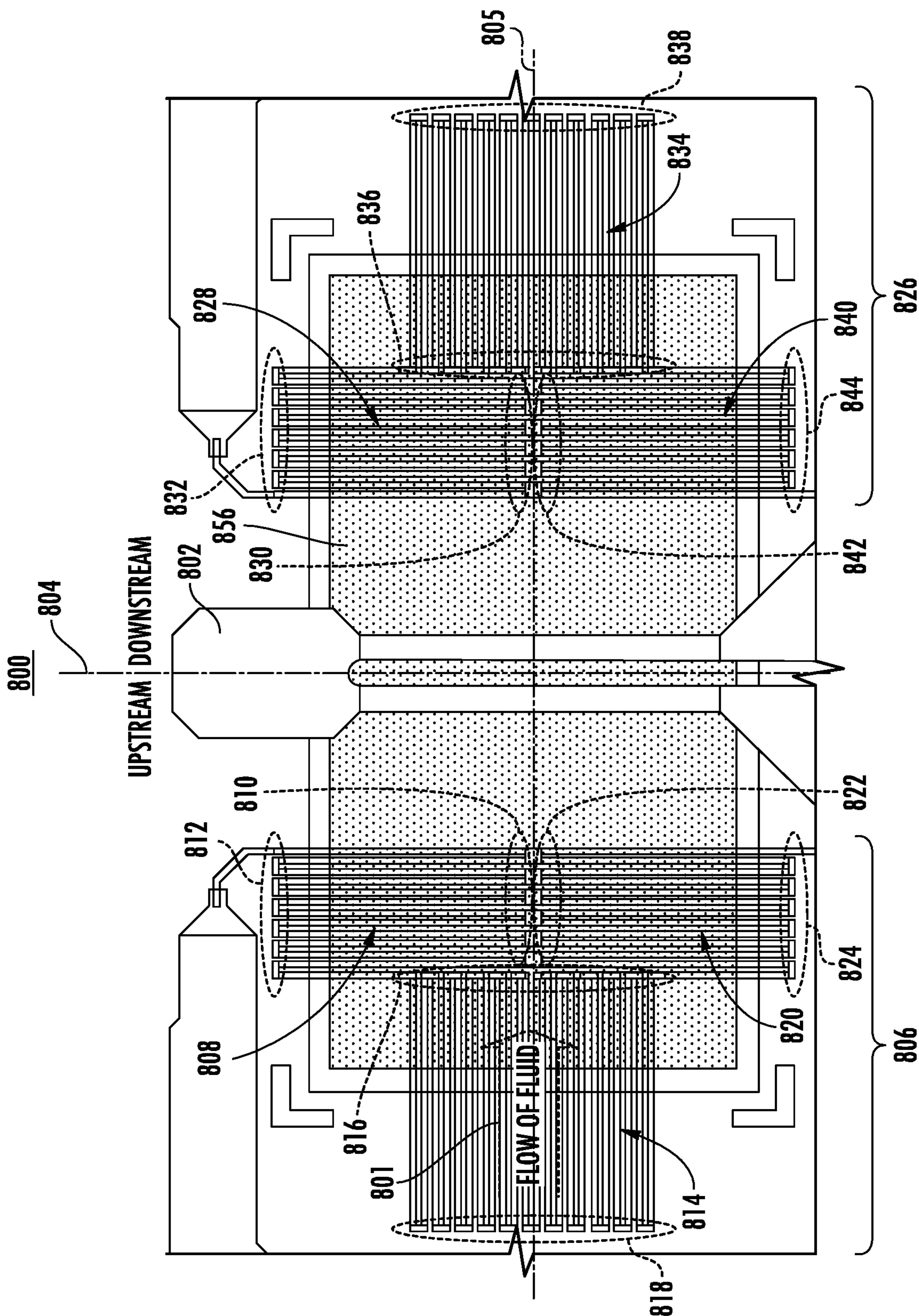

FIG. 8

900

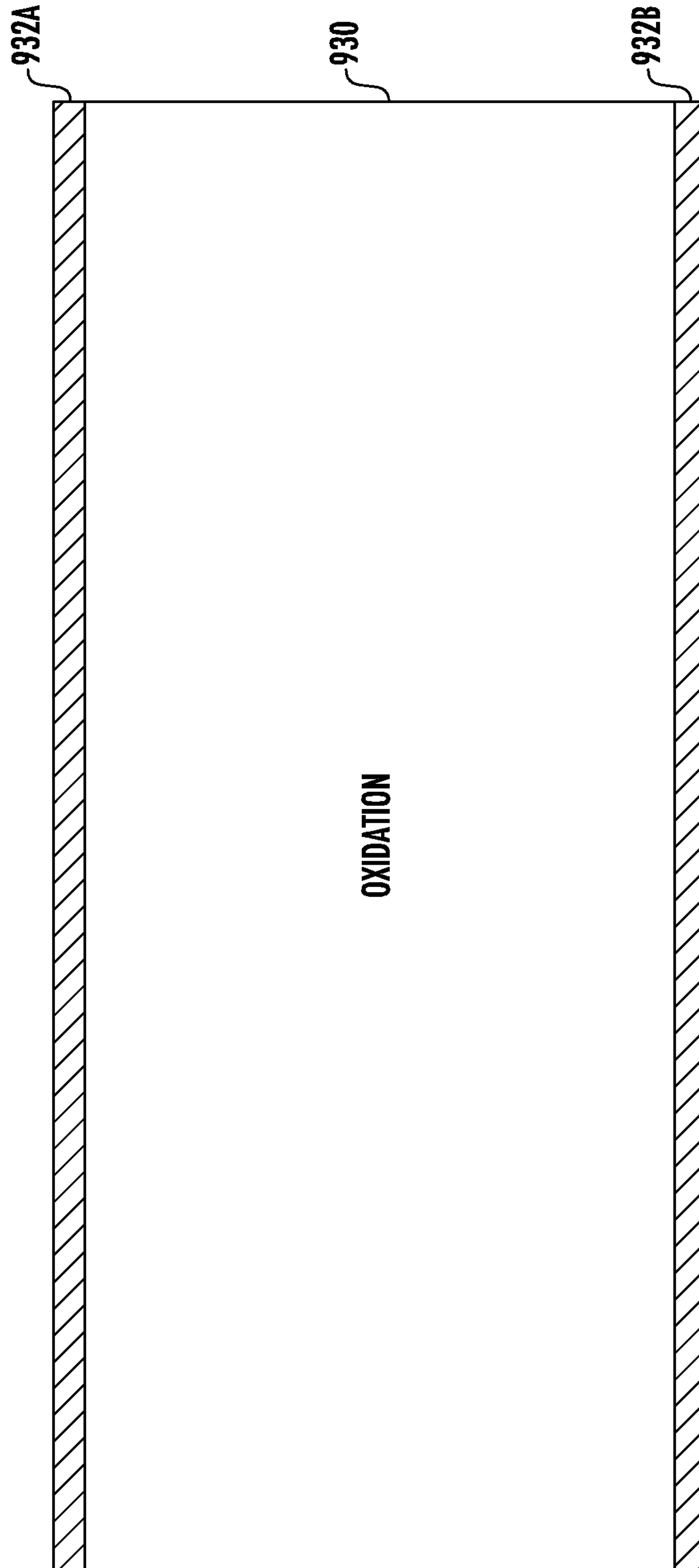

FIG. 9A

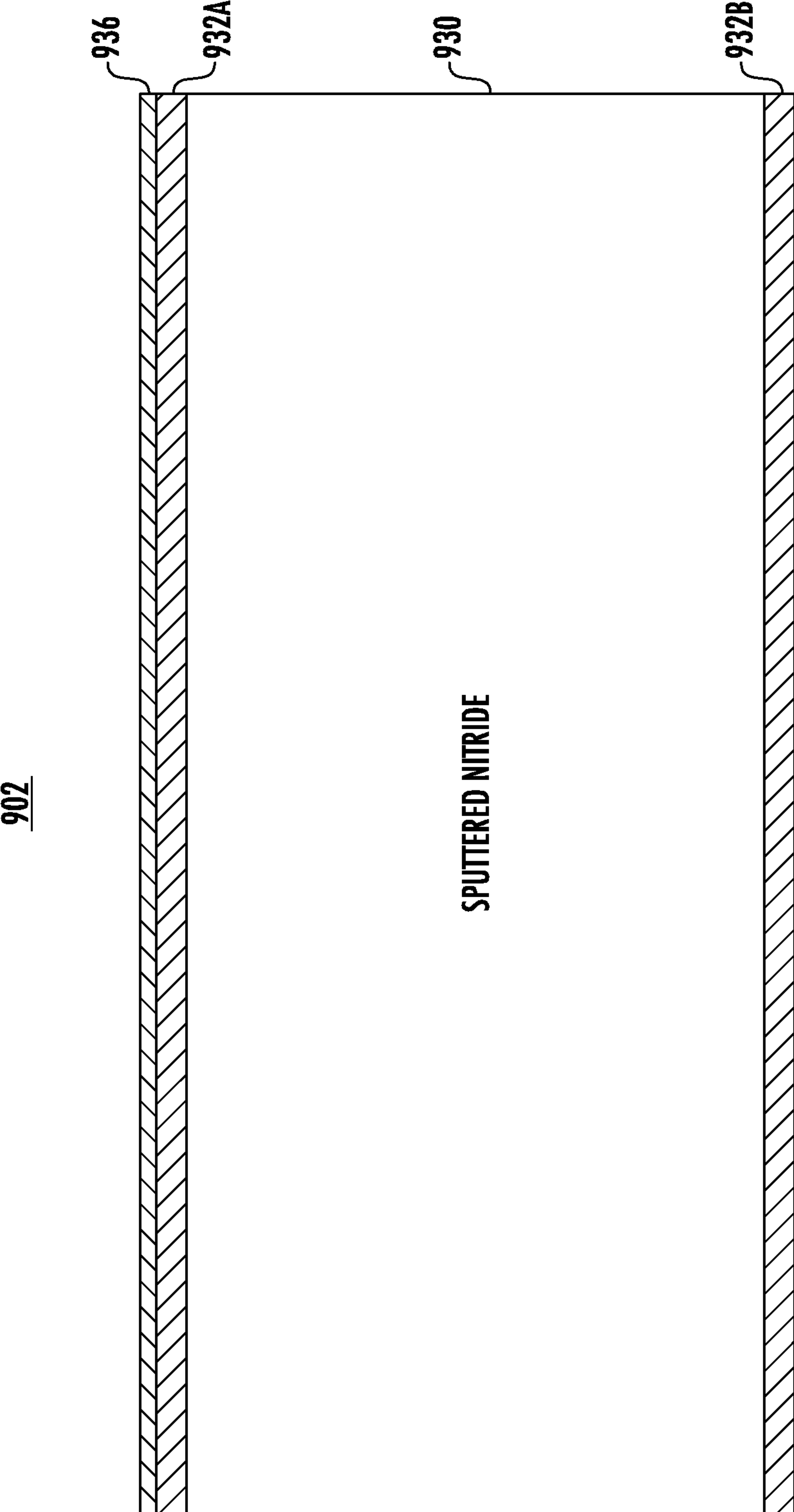

FIG. 9B

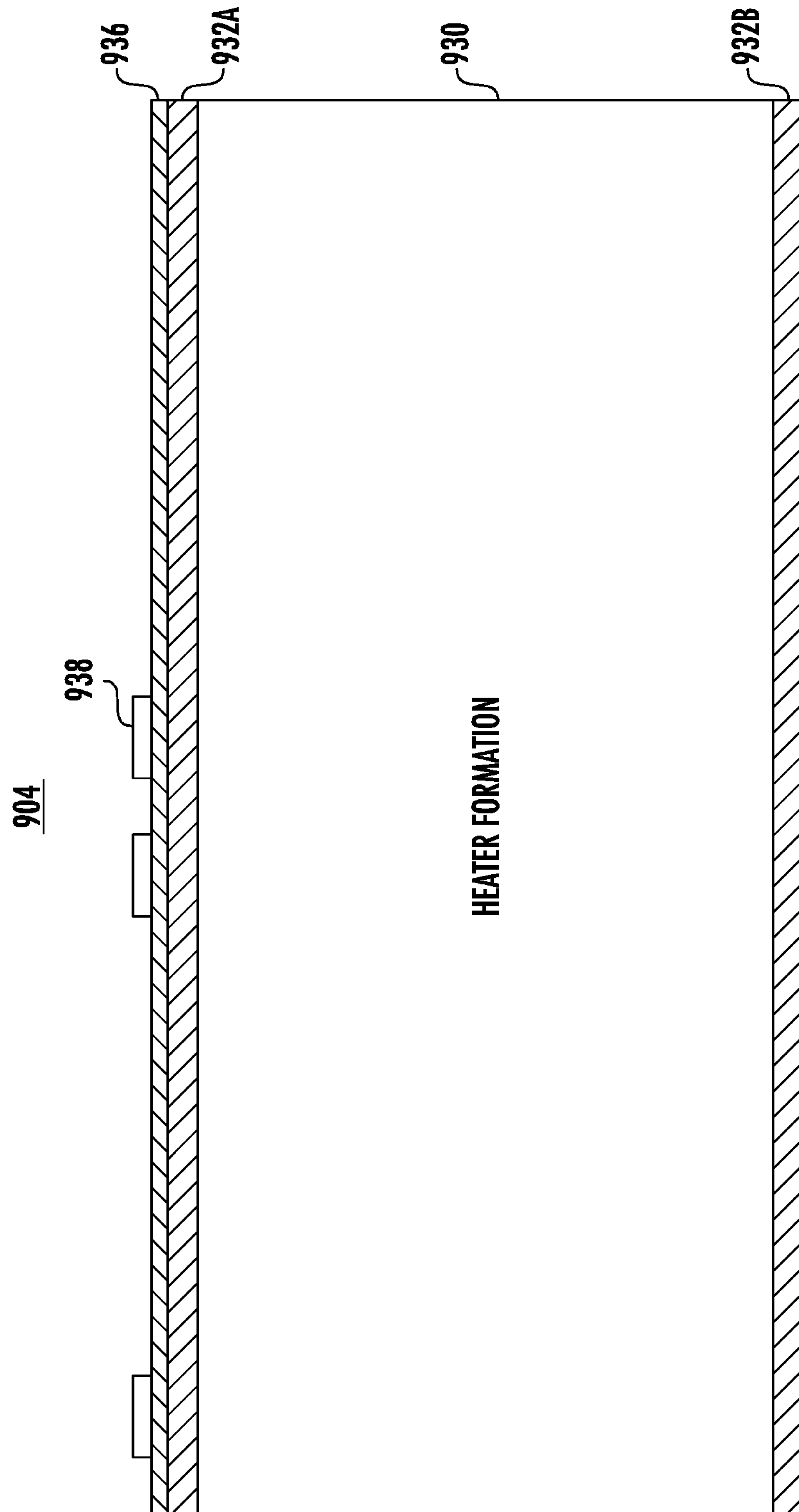

FIG. 9C

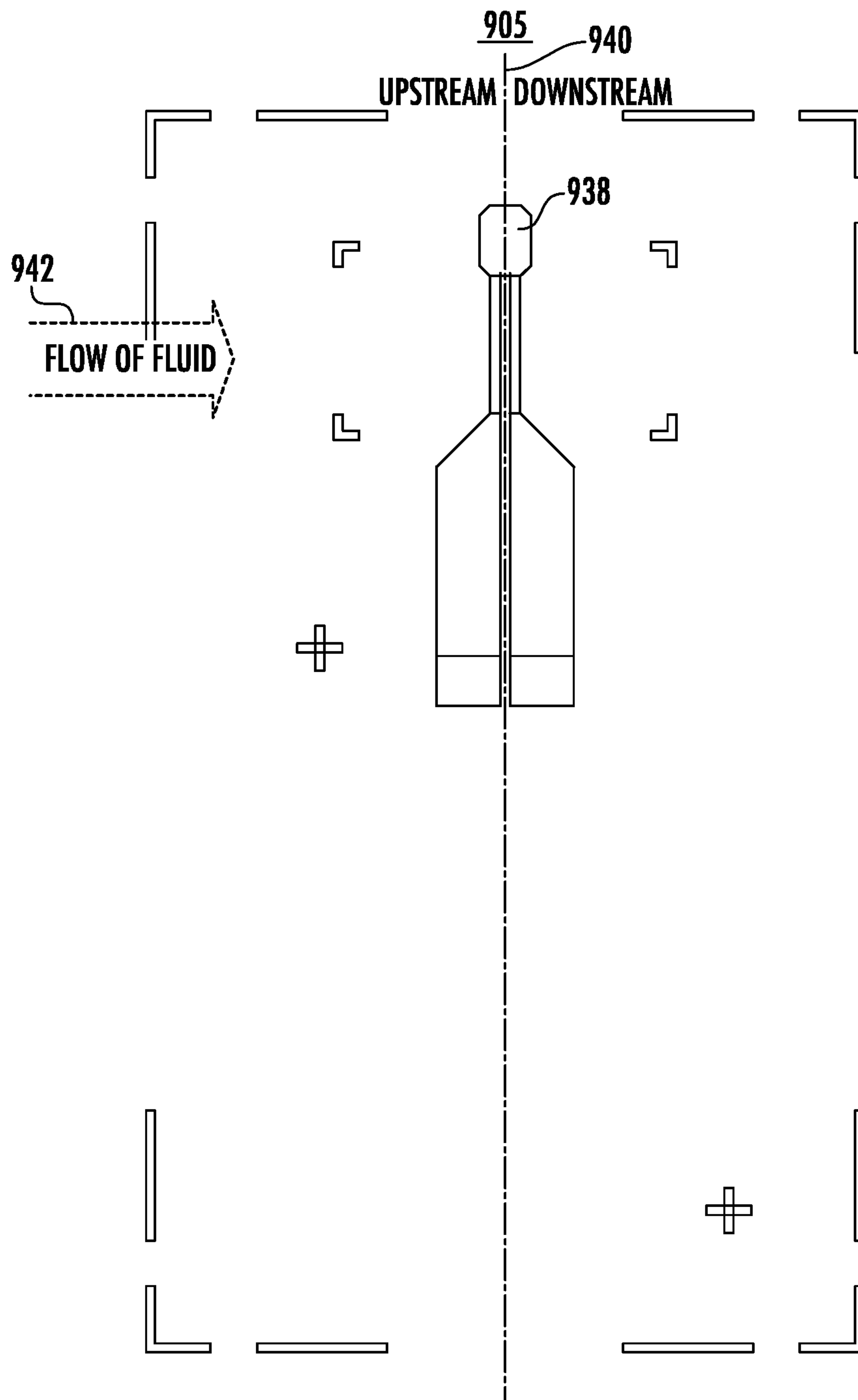

FIG. 9D

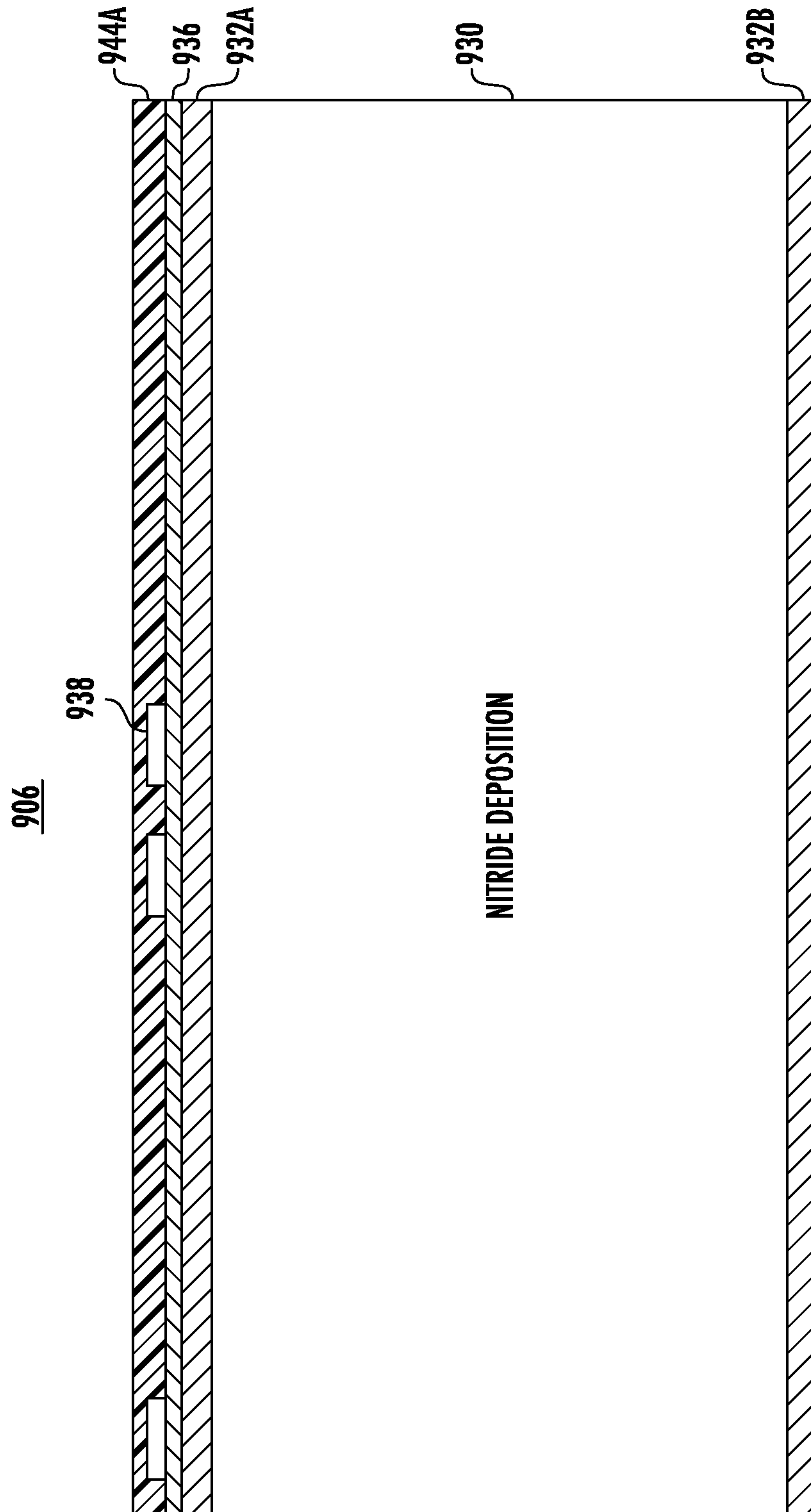

FIG. 9E

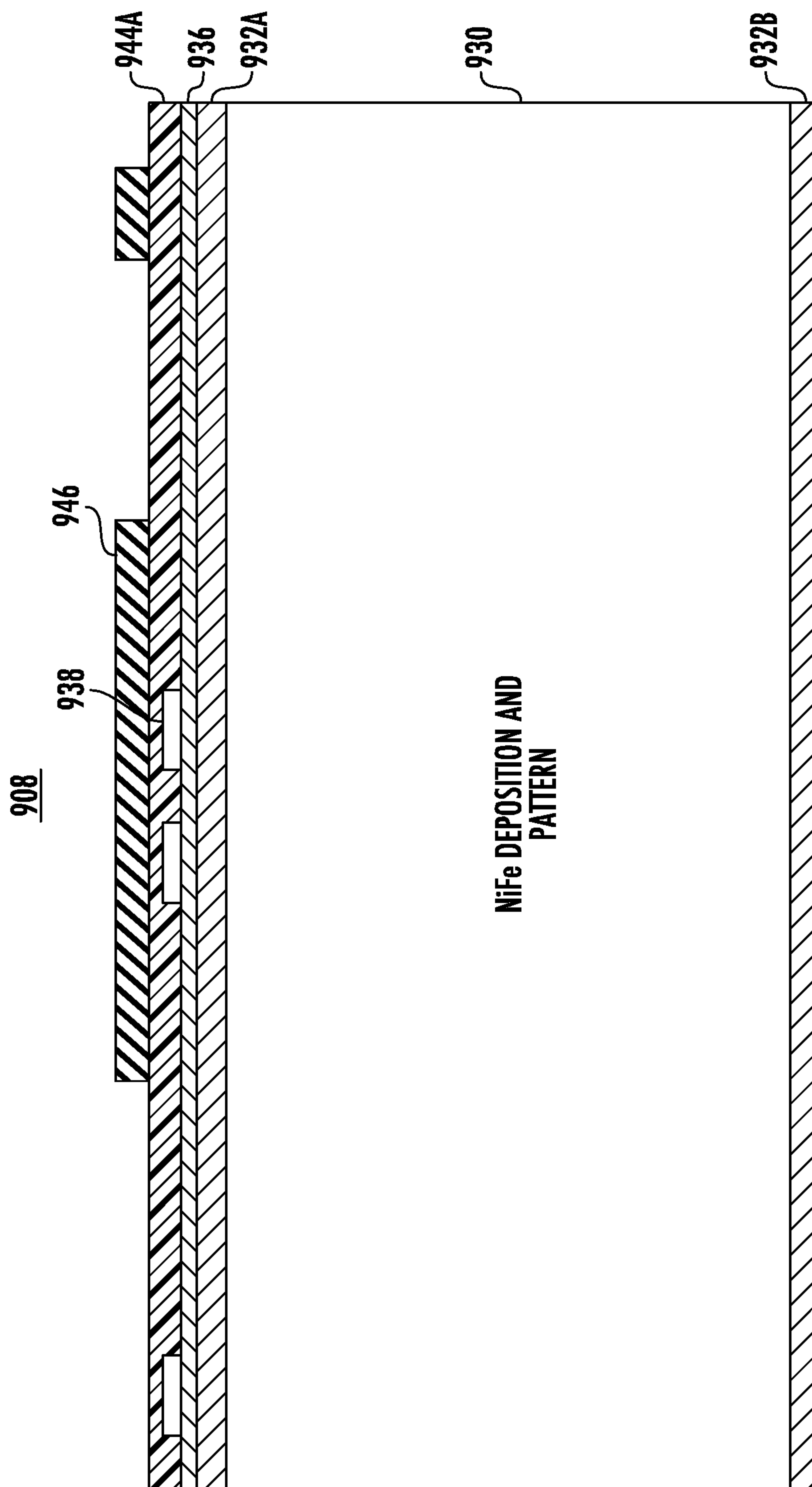

FIG. 9F

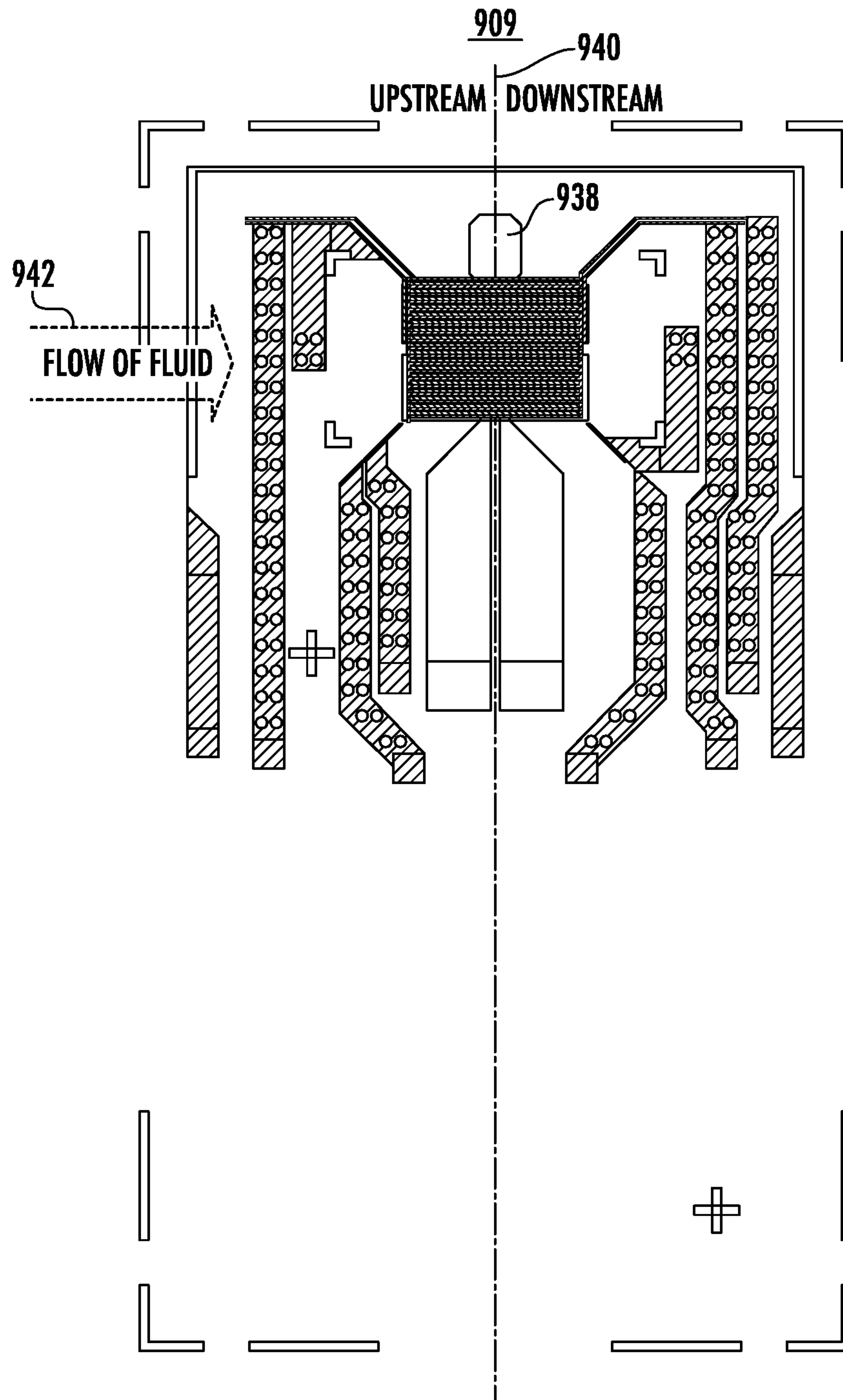

FIG. 9G

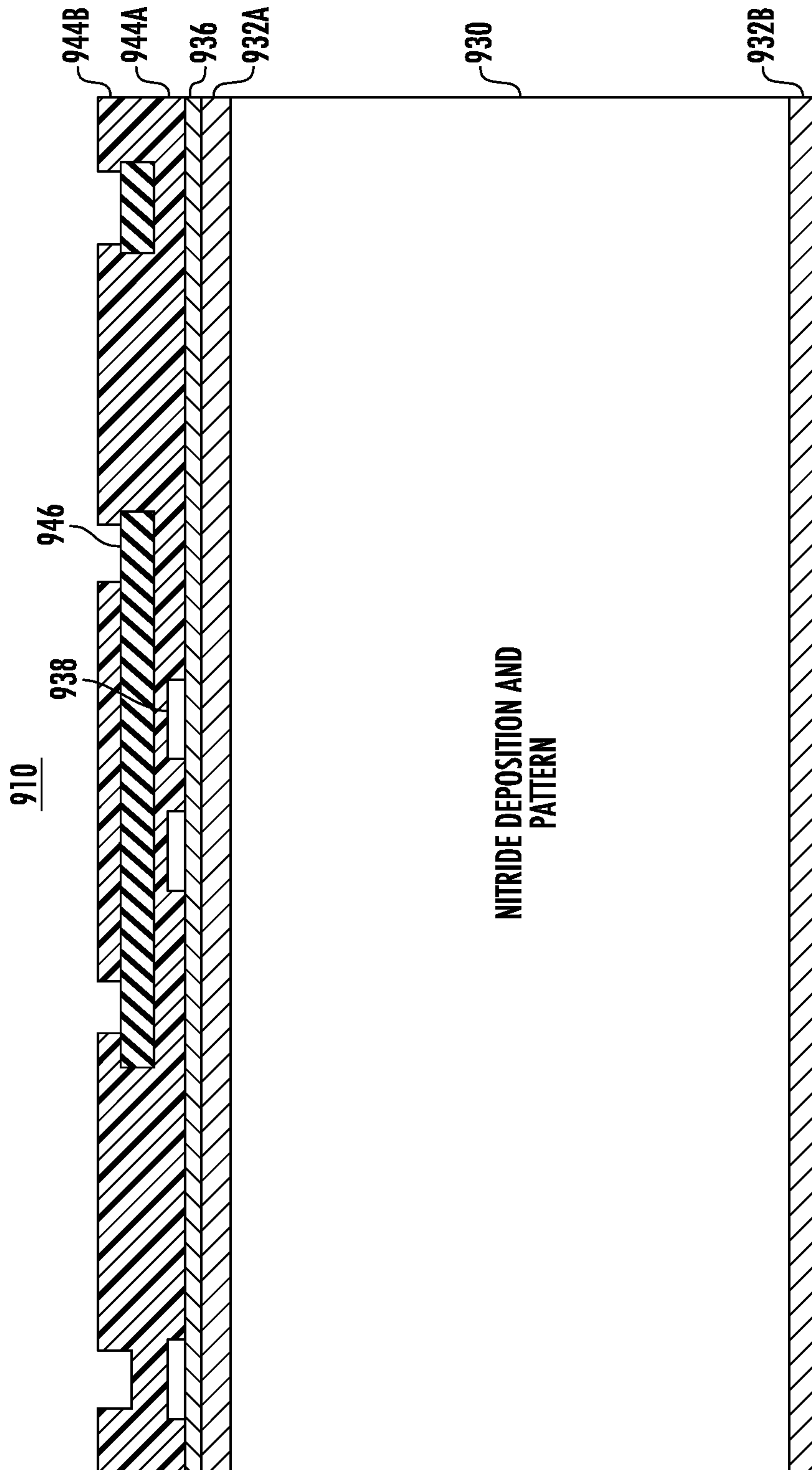

FIG. 9H

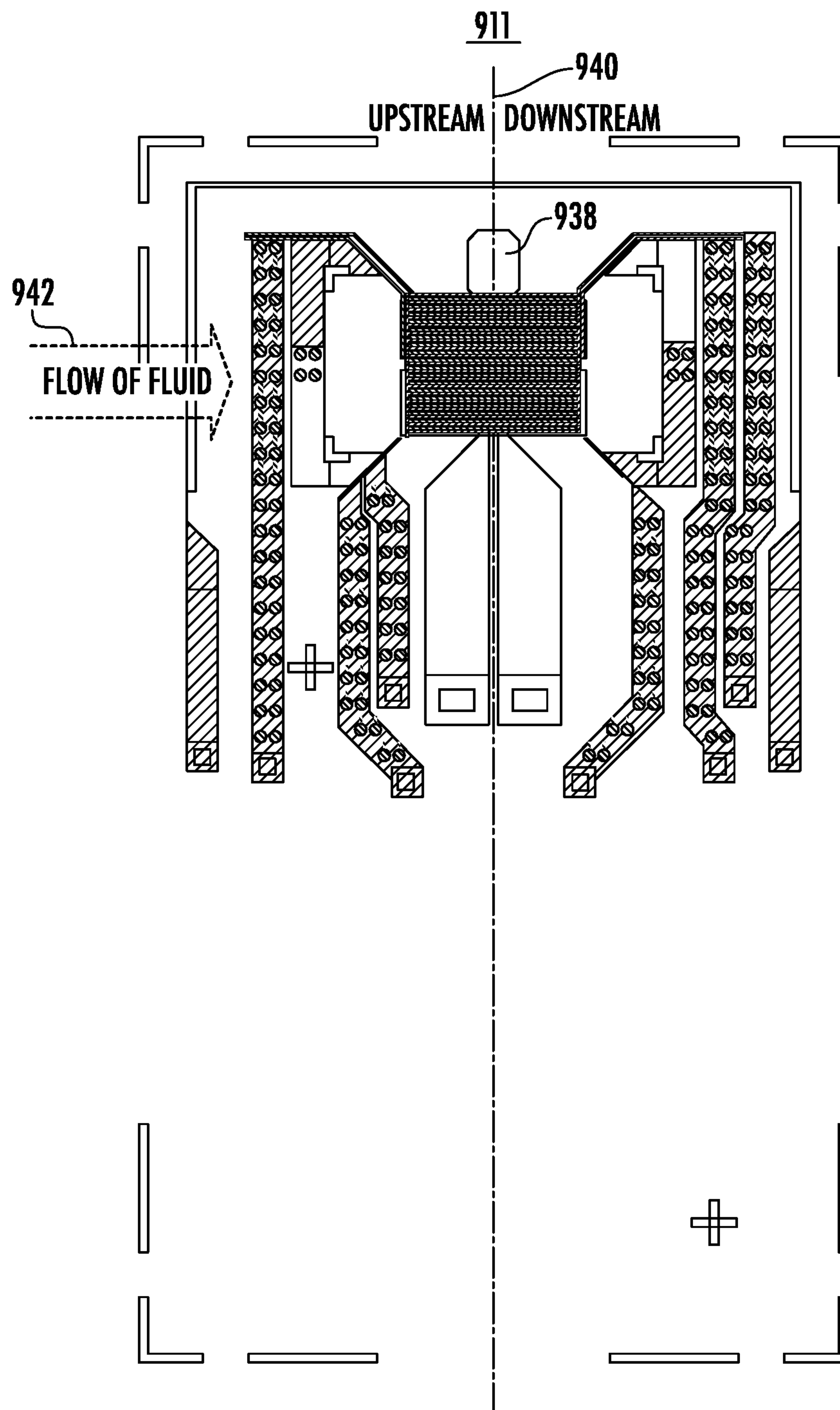
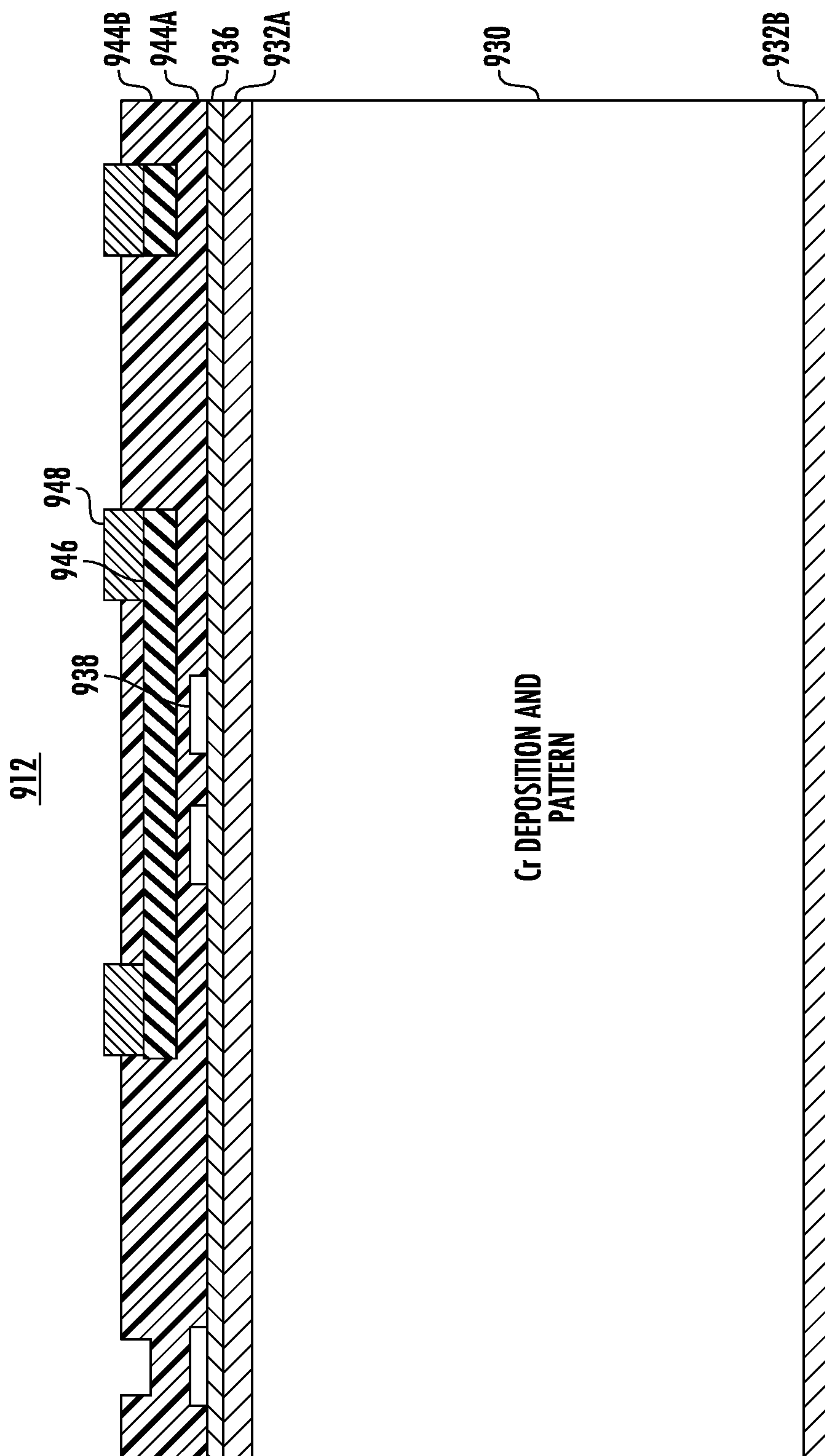

FIG. 91



Cr DEPOSITION AND
PATTERN

FIG. 9J

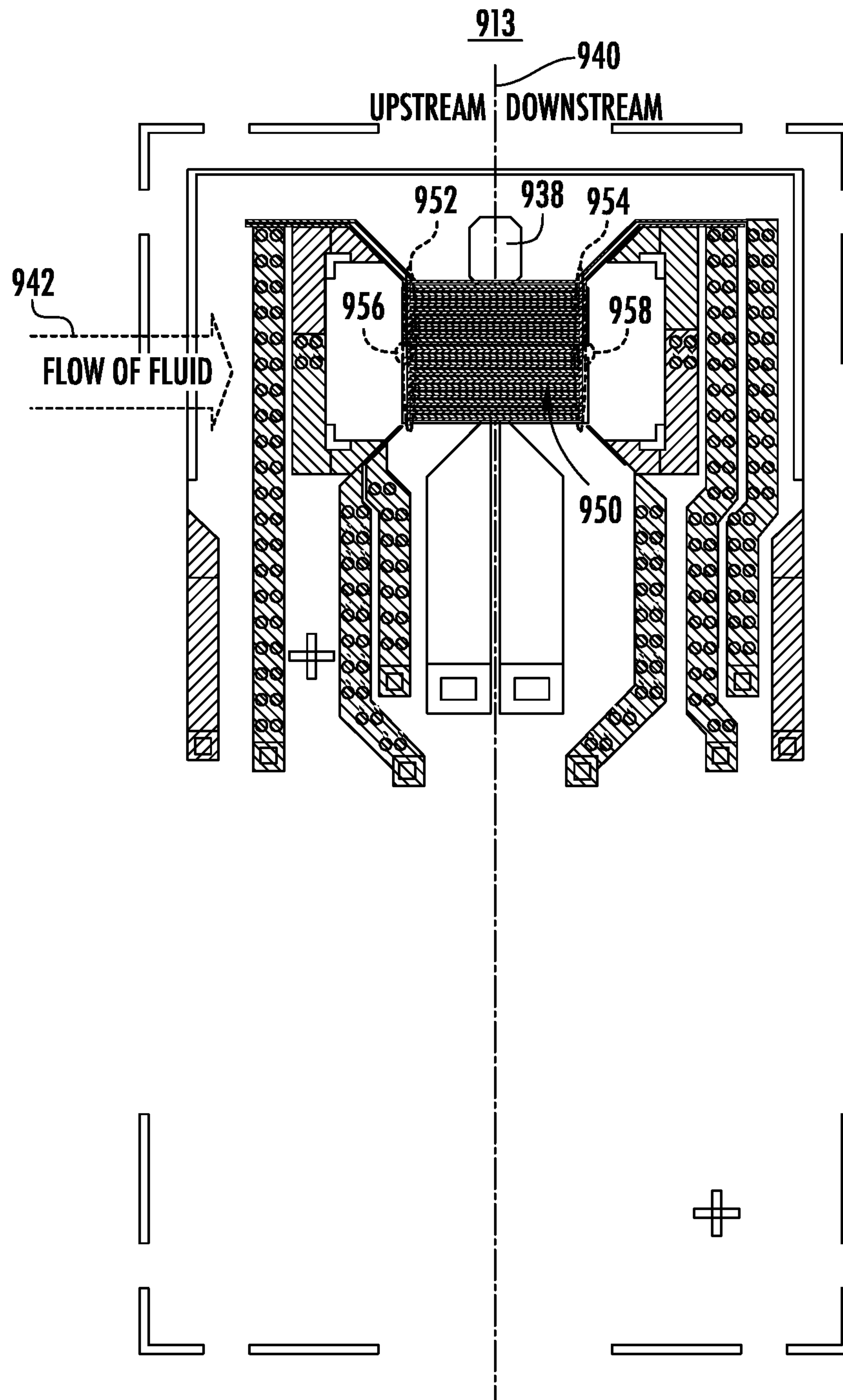

FIG. 9K

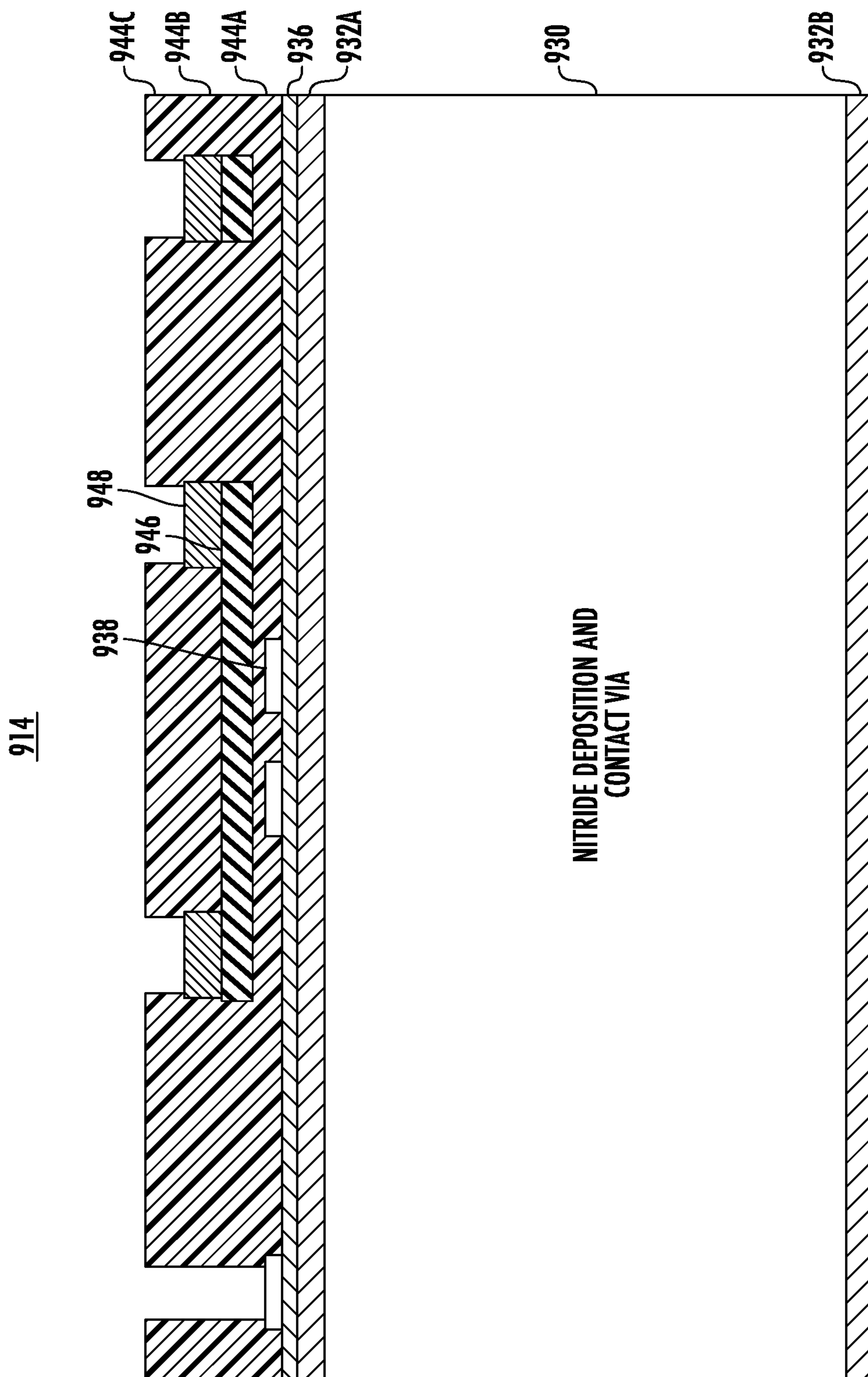

FIG. 9L

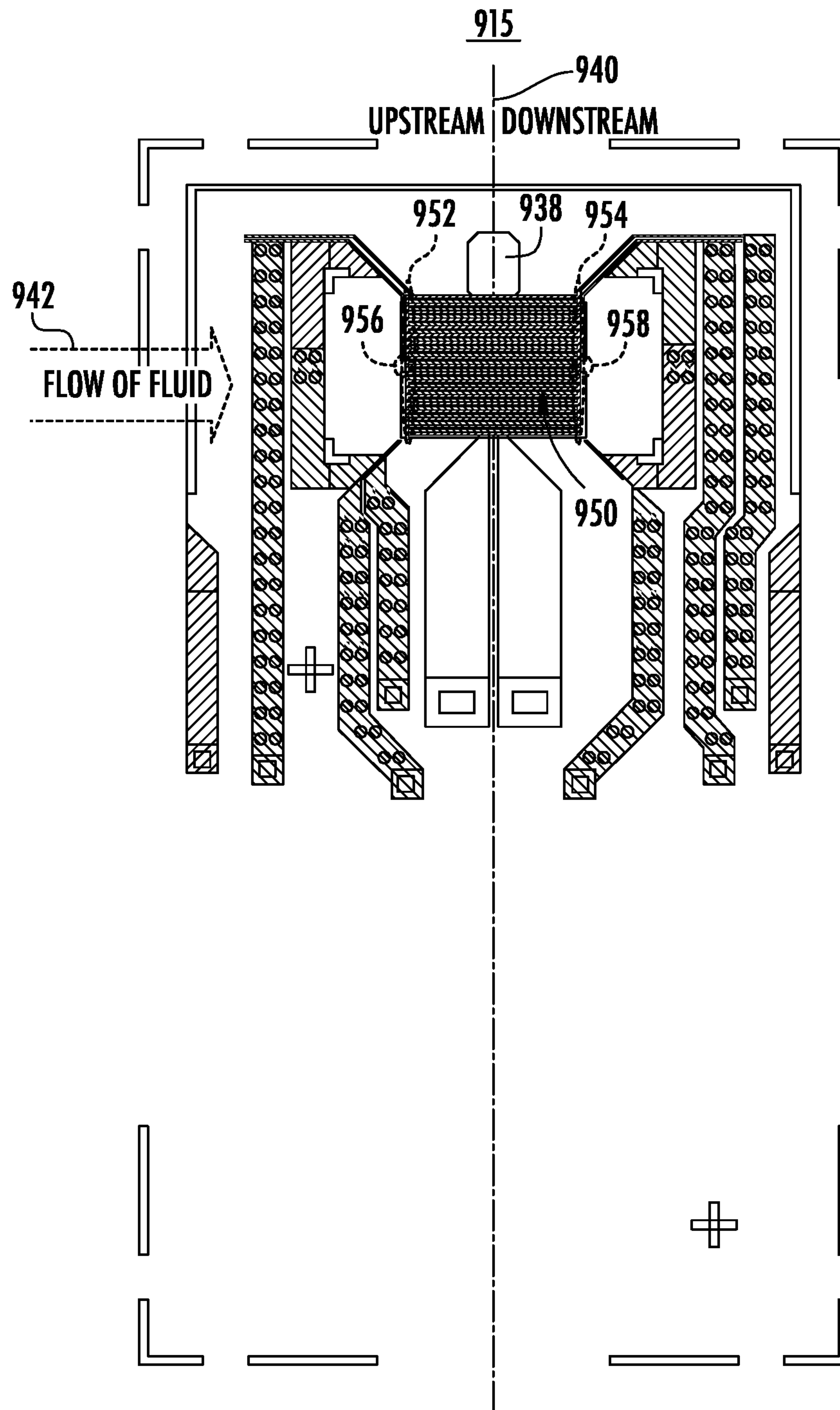

FIG. 9M

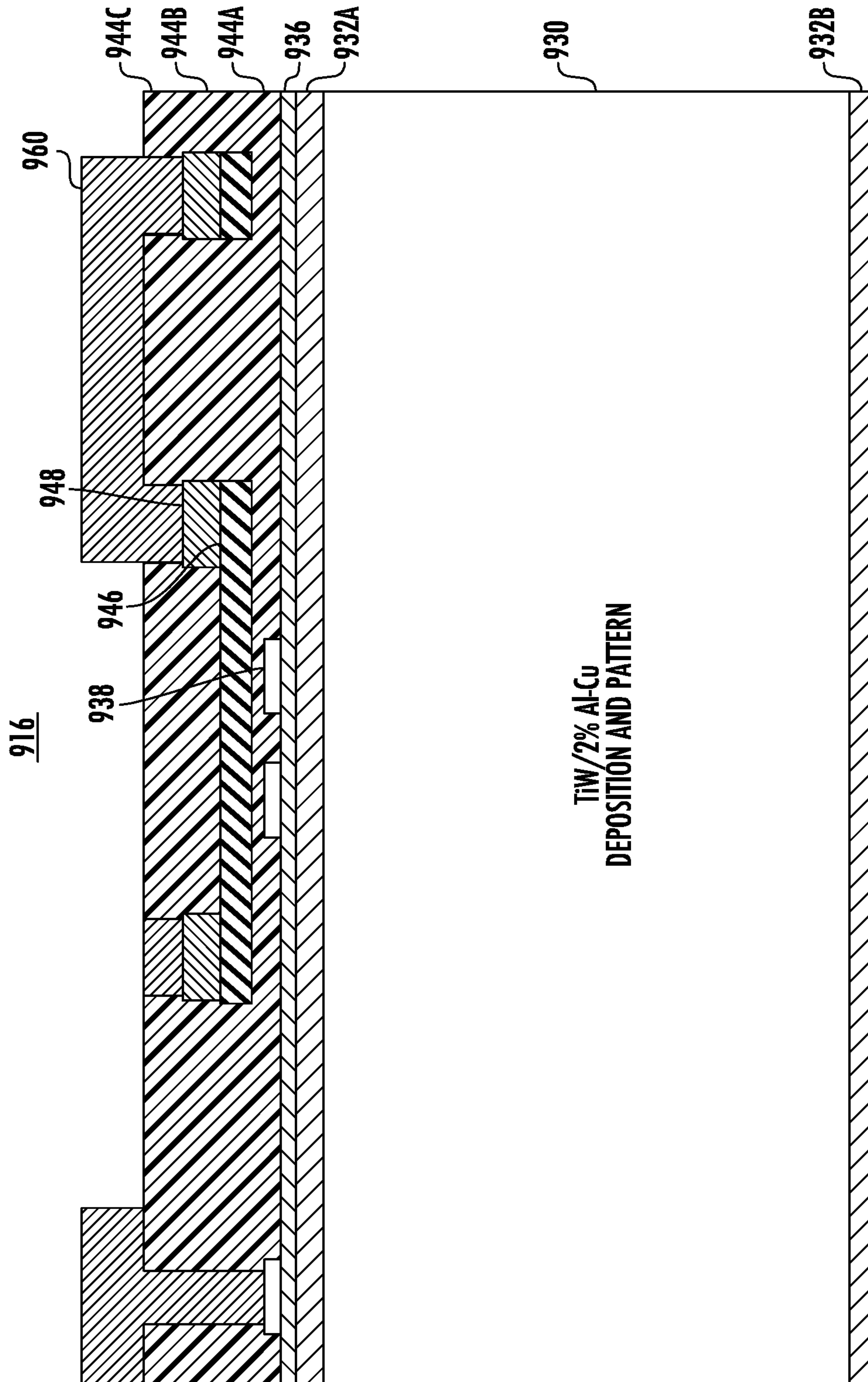

FIG. 9N

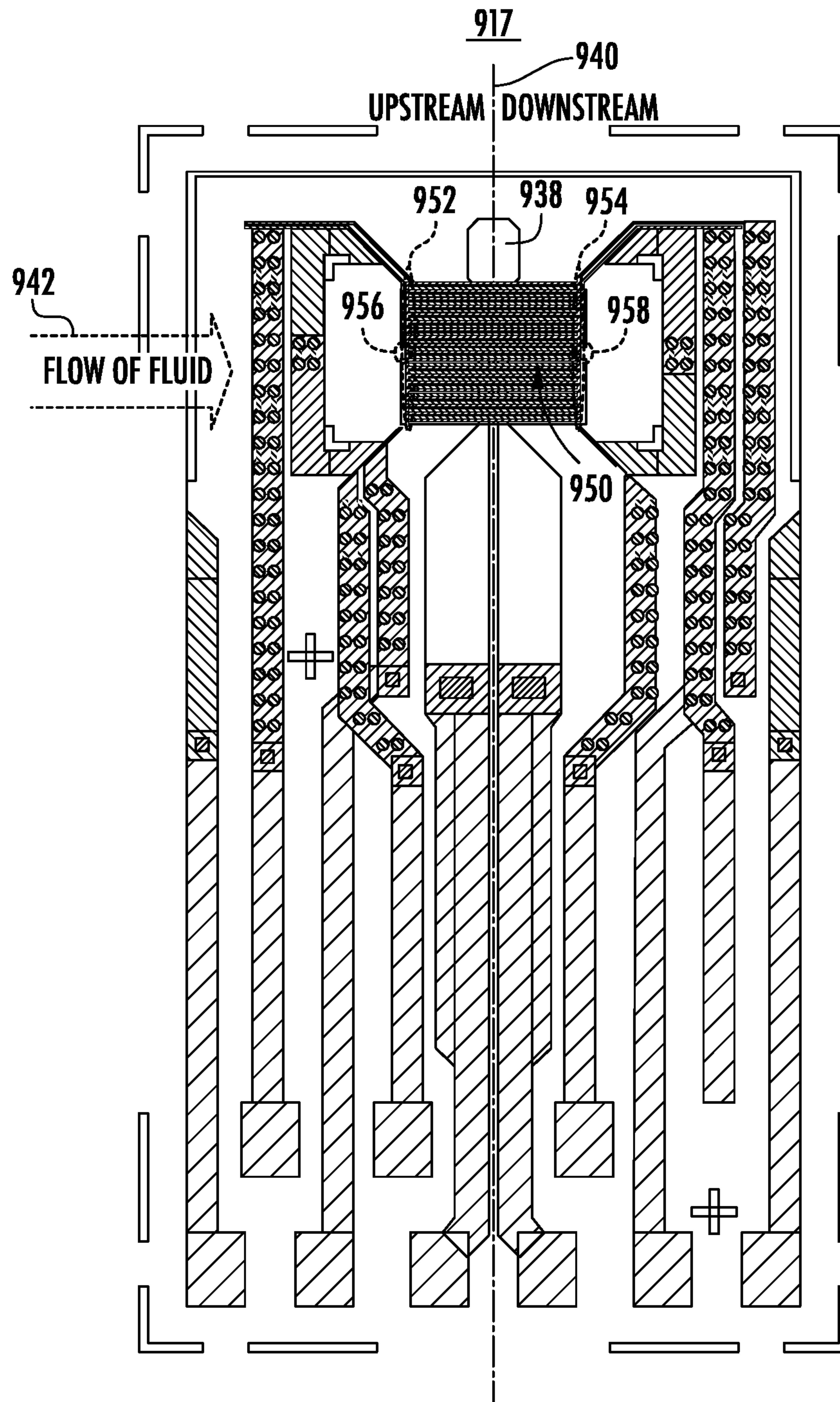
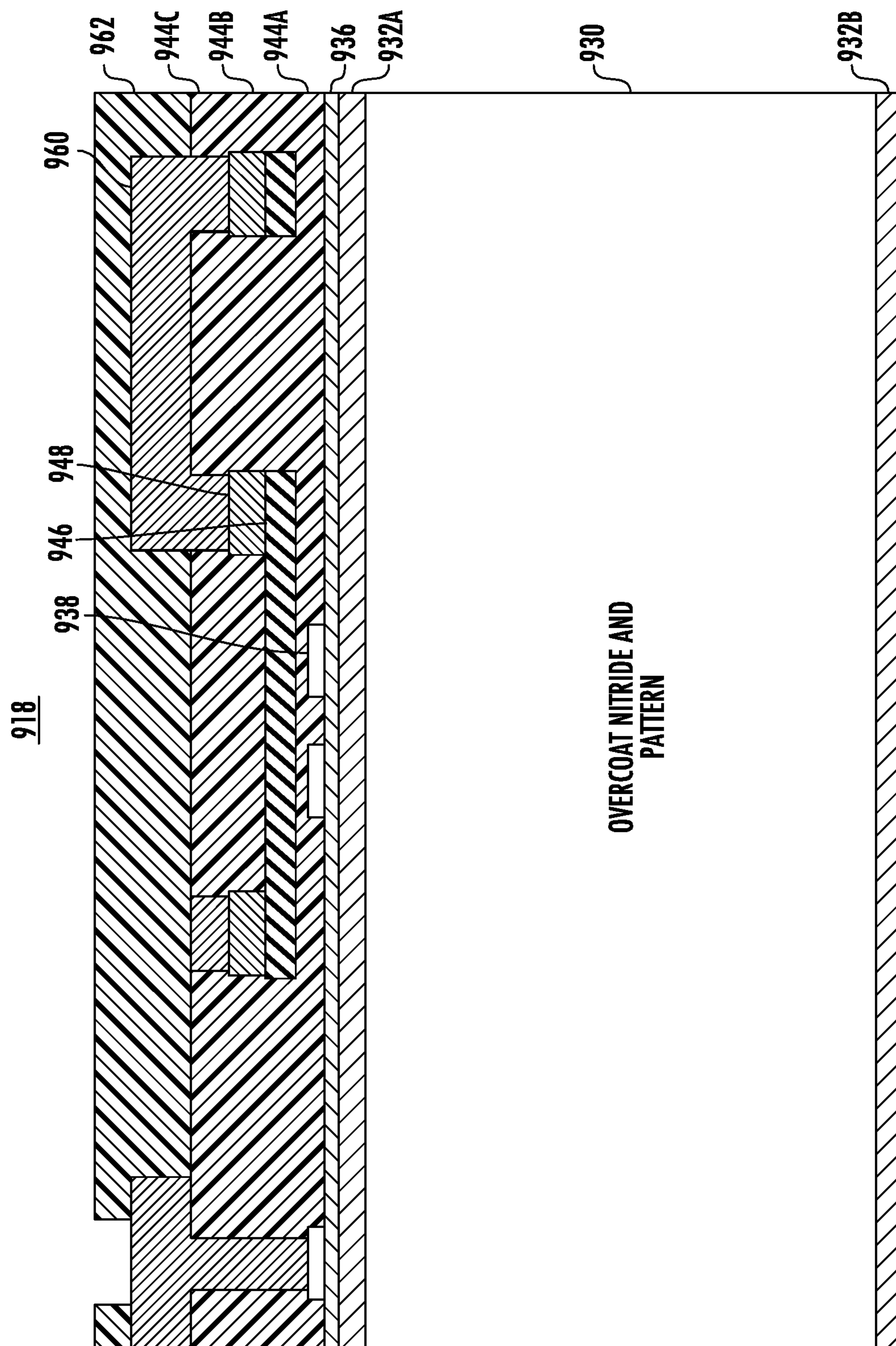

FIG. 90



OVERCOAT NITRIDE AND
PATTERN

FIG. 9P

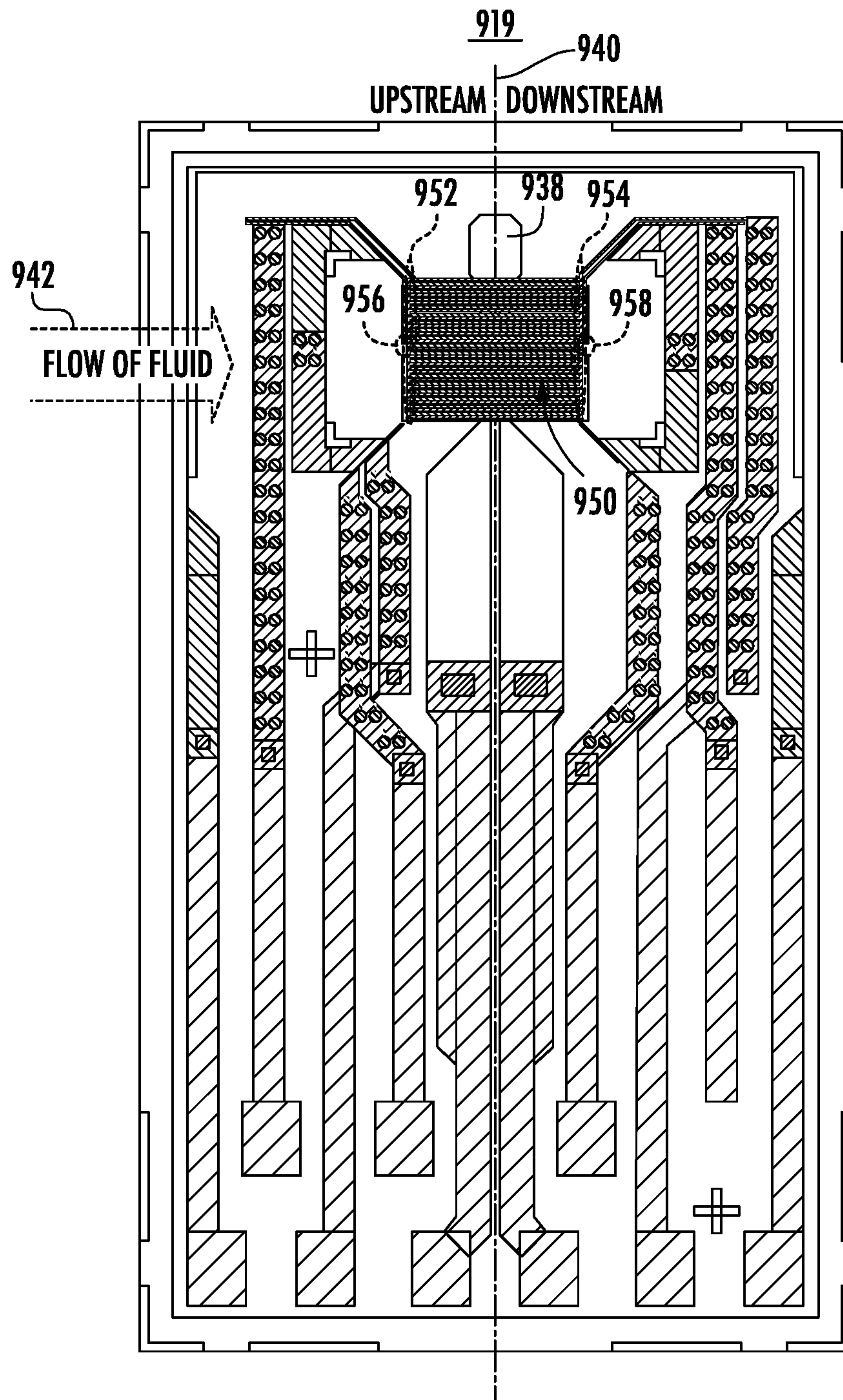

FIG. 9Q

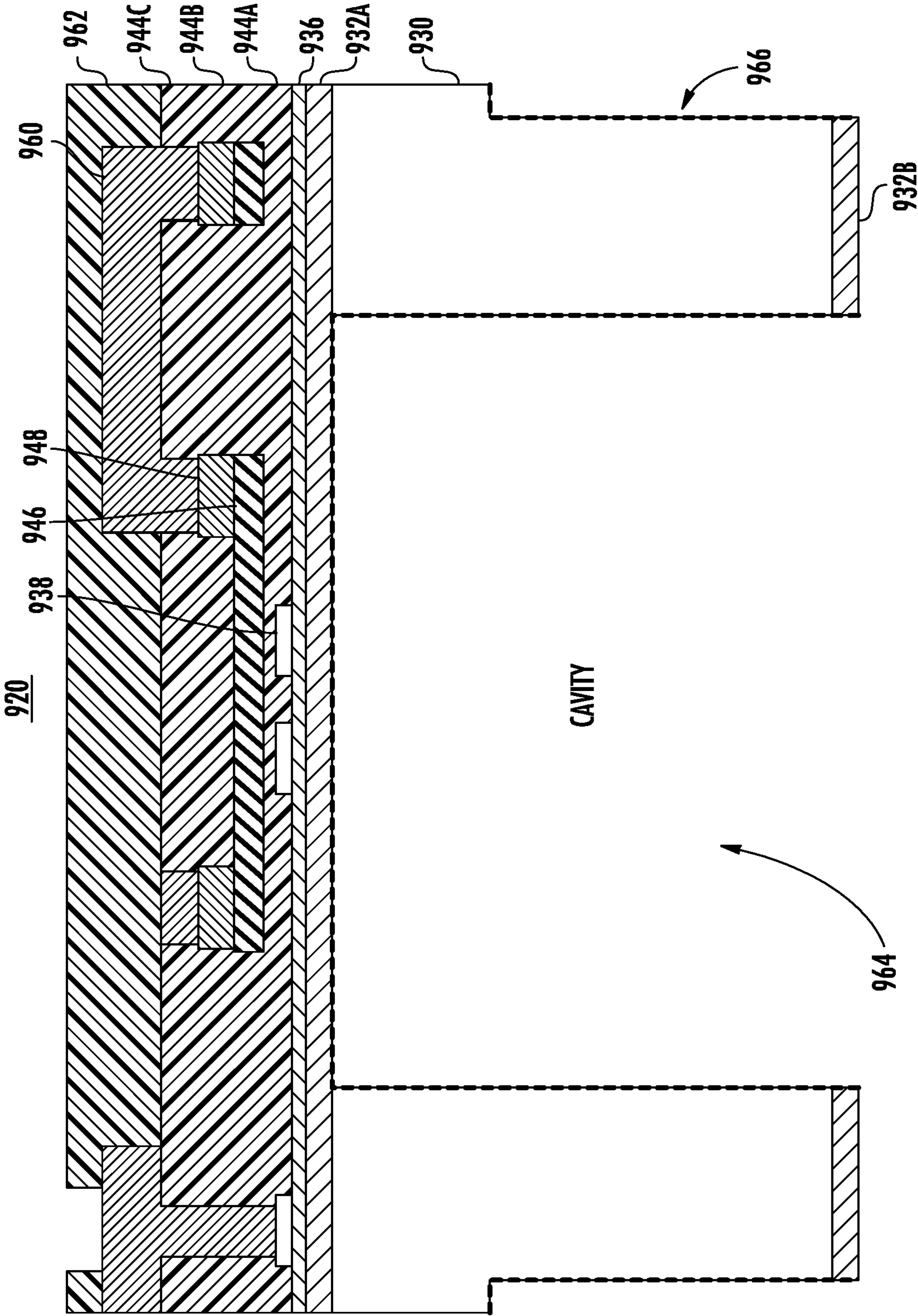

FIG. 9R

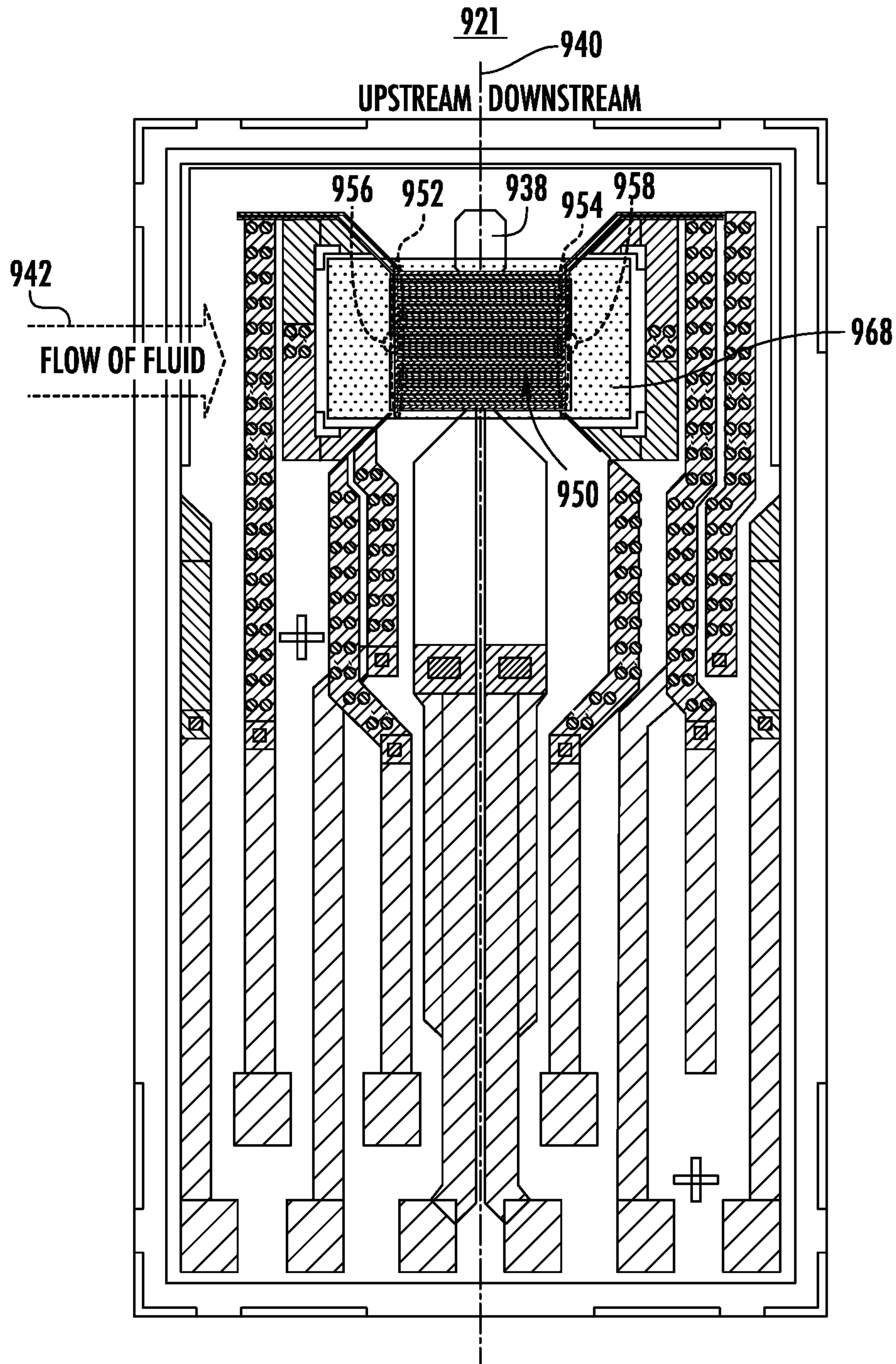

FIG. 9S

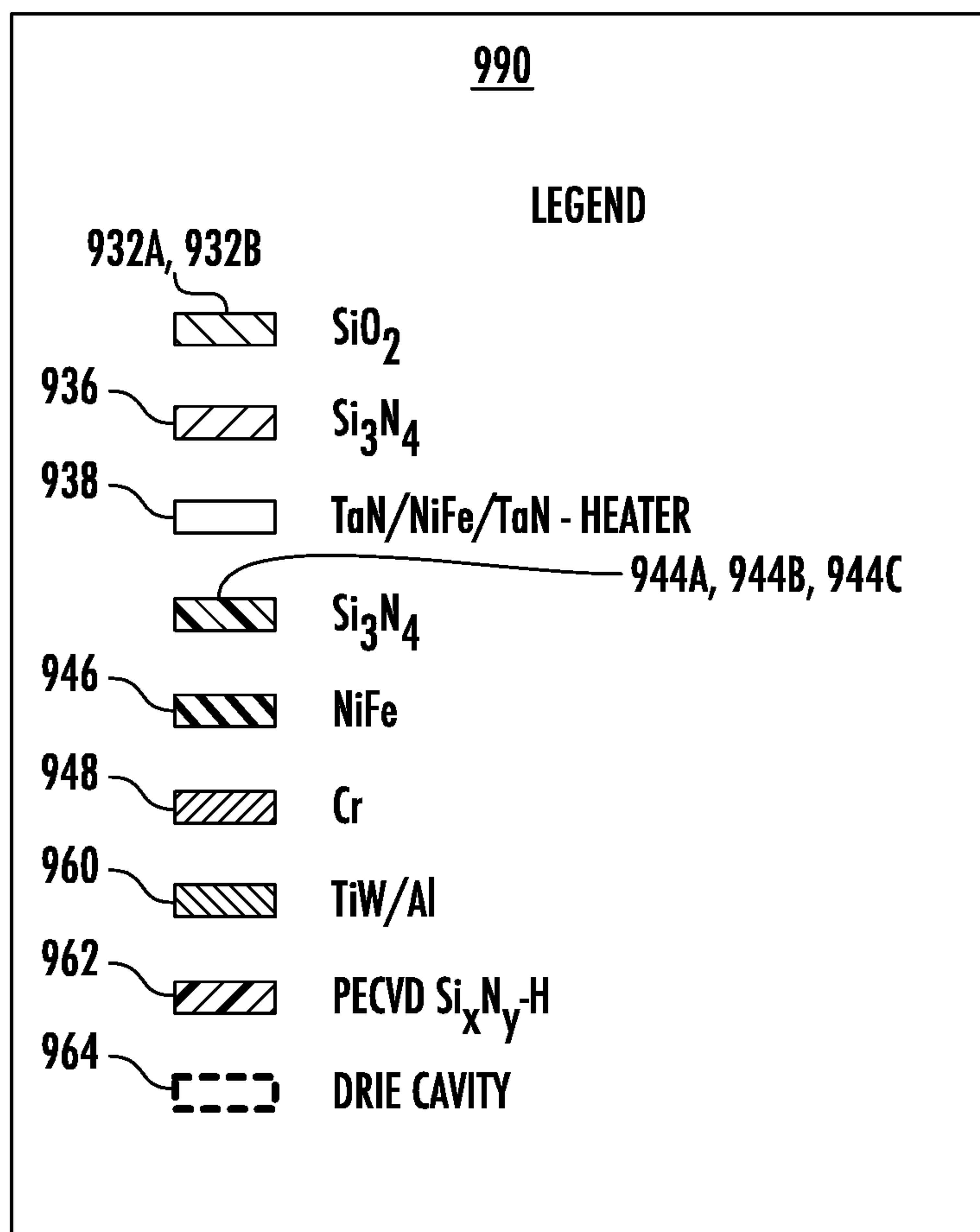

FIG. 9T

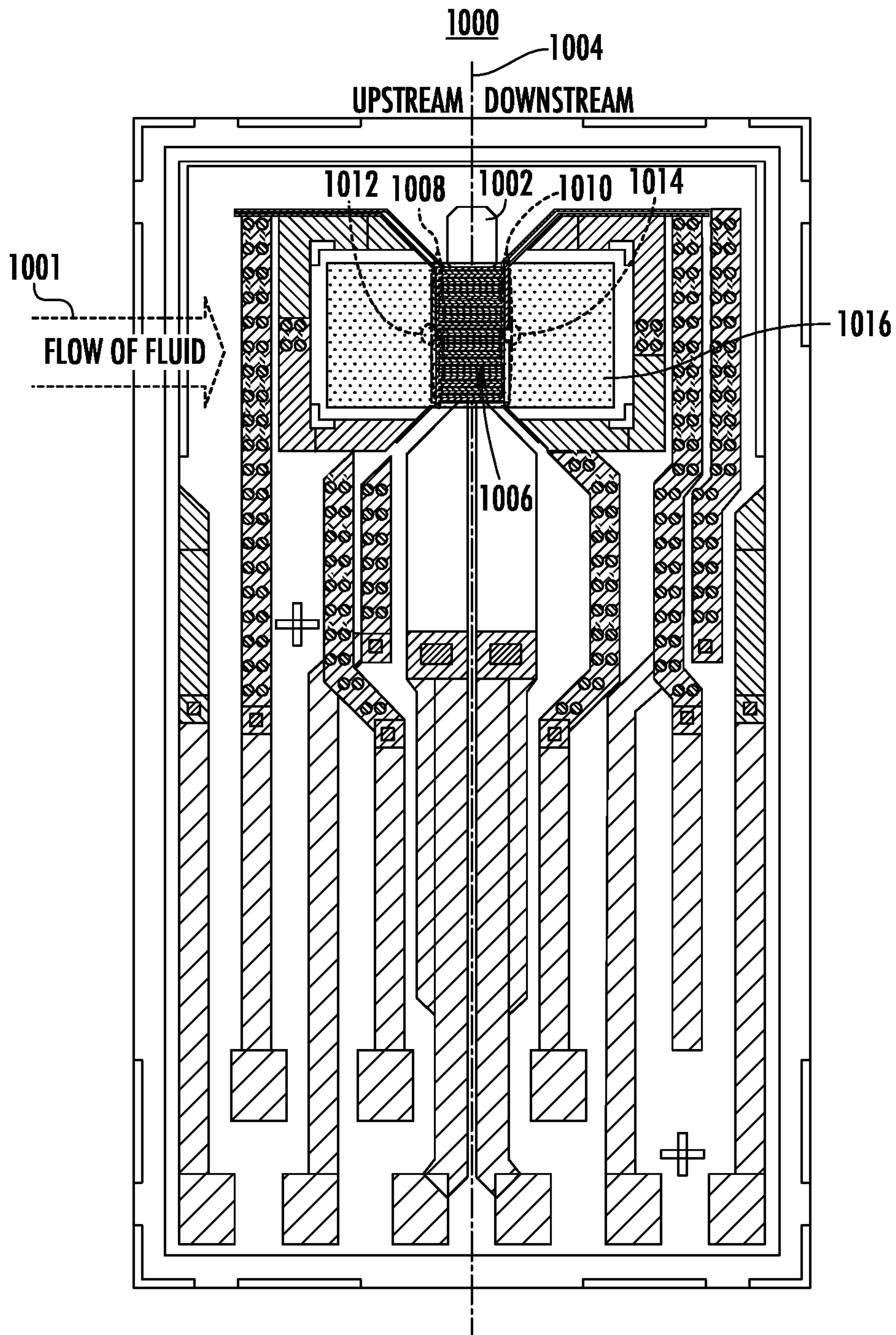

FIG. 10

1100

MATERIAL	TEMP (K)	TE (uV/C)	rho (uohm-cm)	COMMENTS
nPOLY Si	300	-65	800	TE PROPERTY CHANGES WITH DOPING LEVEL.
AuNi(9%)	300	-55	11	
NiFe(40%)	300	-45	20	
Co	300	-31	6	
Ni	300	-19	8	
Ta		-1.9	12.45	
Pt	273	0	10.6	
Al	273	3.5	2.6548	
Ta	273	4.5	12.45	
Ag	273	6.5	1.59	
Cu	273	6.5	1.673	
Au	273	6.5	2.35	
W	273	7.5	5.65	
Cu	300	7.6		
Ti		9.1	42	
NiCr(2%)	300	20	16	
Cr	300	22	13	
NiCr(10%)	300	25	70	
pPOLY Si	300	135	5500	TE PROPERTY CHANGES WITH DOPING LEVEL.
p-Si	300	220	13000000	TE PROPERTY CHANGES WITH DOPING LEVEL.
p-Si	200	1000	3000000	TE PROPERTY CHANGES WITH DOPING LEVEL.
p-Si	77	20000	300000	

FIG. 11

1200

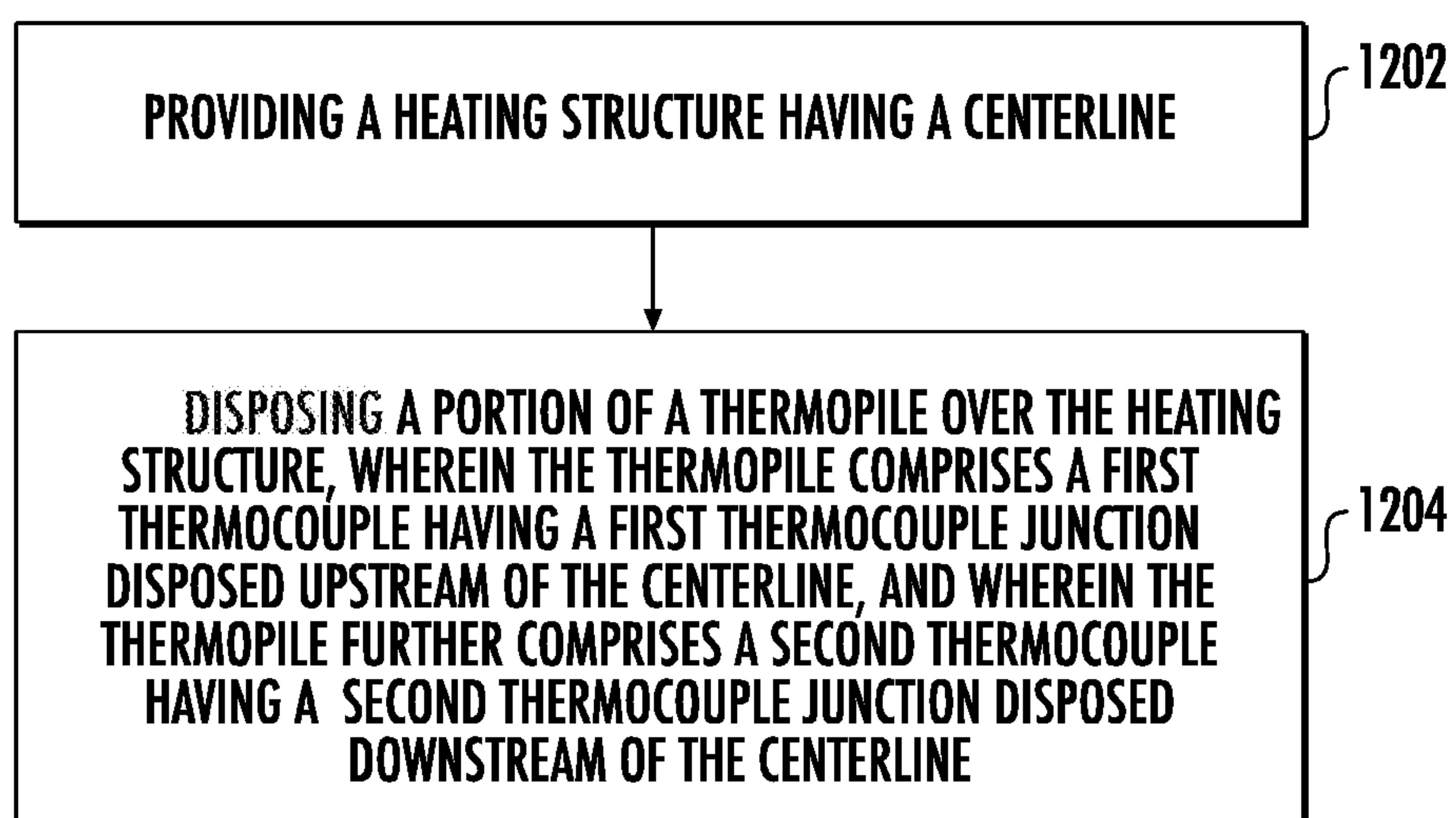
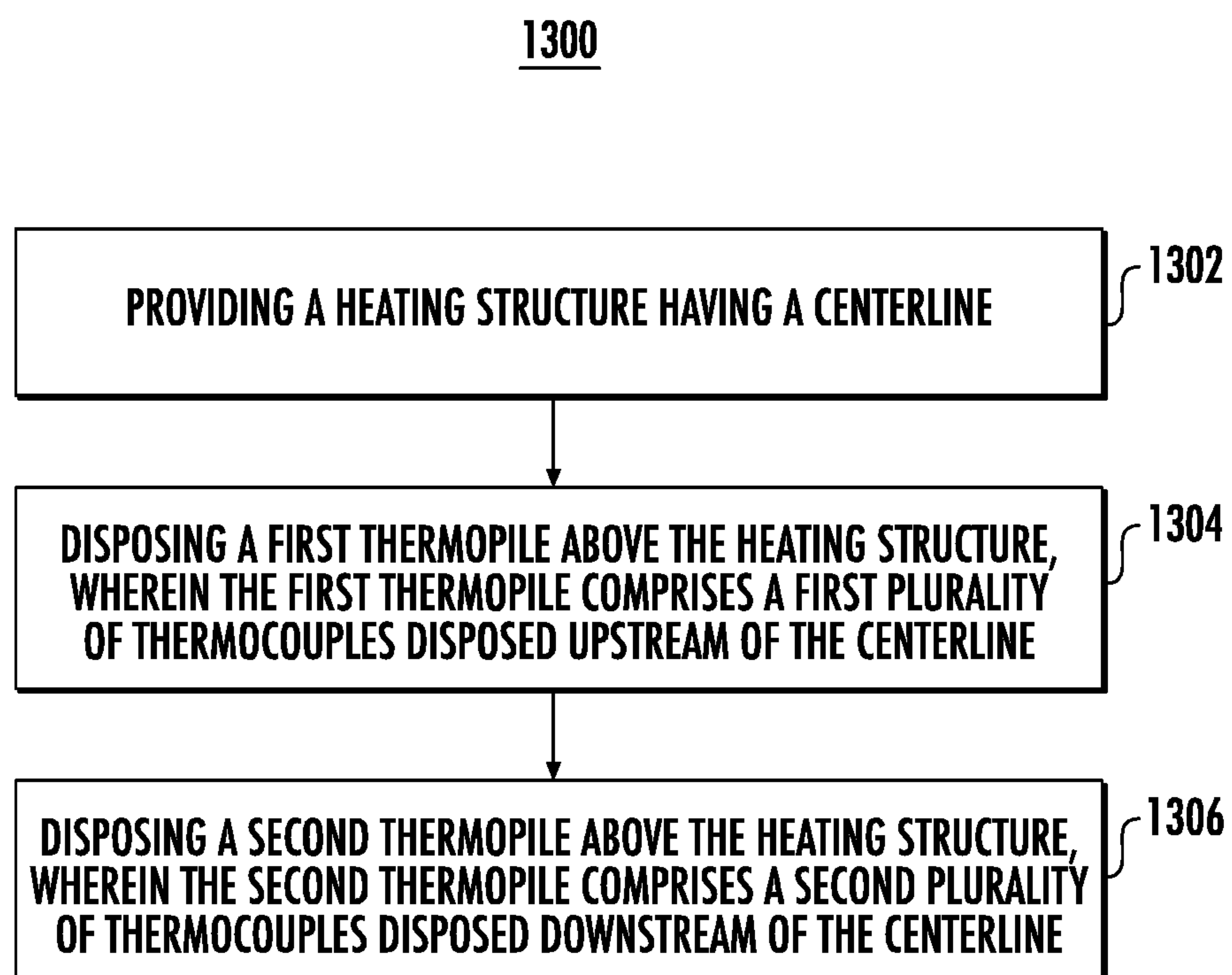

FIG. 12

**FIG. 13**

THERMOPHILE-BASED FLOW SENSING DEVICE

TECHNOLOGICAL FIELD

Example embodiments of the present disclosure relate generally to sensors and, more particularly, to flow sensors.

BACKGROUND

Industrial and commercial applications are increasingly utilizing flow sensors to measure and control the mass flow rates of gases and liquids. However, conventional flow sensor designs often exhibit drift characteristics that decrease their measurement sensitivities.

Applicant has identified a number of deficiencies and problems associated with conventional flow sensors. Through applied effort, ingenuity, and innovation, many of these identified problems have been solved by developing solutions that are included in embodiments of the present disclosure, many examples of which are described in detail herein.

SUMMARY

Systems, apparatuses, methods, and computer program products are disclosed herein for providing for a thermopile-based flow sensing device that exhibits low drift or no drift characteristics that, in some instances, is compatible with complementary metal-oxide-semiconductor (CMOS) processing.

In one example embodiment, an apparatus is provided for sensing a flow of fluid. The apparatus may comprise a flow sensing device comprising a heating structure having a centerline. The flow sensing device may further comprise a thermopile. At least a portion of the thermopile may be disposed over the heating structure. The thermopile may comprise a first thermocouple having a first thermocouple junction disposed upstream of the centerline of the heating structure. The thermopile may further comprise a second thermocouple having a second thermocouple junction disposed downstream of the centerline of the heating structure.

In another example embodiment, a method is provided for manufacturing an apparatus for sensing a flow of fluid. The method may comprise providing a heating structure having a centerline. The method may further comprise disposing at least a portion of a thermopile over the heating structure. The thermopile may comprise a first thermocouple having a first thermocouple junction disposed upstream of the centerline of the heating structure. The thermopile may further comprise a second thermocouple having a second thermocouple junction disposed downstream of the centerline of the heating structure.

In yet another example embodiment, an apparatus for sensing a flow of fluid. The apparatus may comprise a flow sensing device comprising a heating structure having a centerline. The flow sensing device may further comprise a first thermopile comprising a first plurality of thermocouples disposed upstream of the centerline of the heating structure. The first plurality of thermocouples may comprise a first subset of the first plurality of thermocouples aligned substantially parallel to the centerline of the heating structure. The first plurality of thermocouples may further comprise a second subset of the first plurality of thermocouples aligned substantially perpendicular to the centerline of the heating structure. The flow sensing device may further comprise a second thermopile comprising a second plurality of thermo-

couples disposed downstream of the centerline of the heating structure. The second plurality of thermocouples may comprise a third subset of the second plurality of thermocouples aligned substantially parallel to the centerline of the heating structure. The second plurality of thermocouples may further comprise a fourth subset of the second plurality of thermocouples aligned substantially perpendicular to the centerline of the heating structure.

In yet another example embodiment, a method is provided for manufacturing an apparatus for sensing a flow of fluid. The method may comprise providing a heating structure having a centerline. The method may further comprise disposing a first thermopile upstream of the centerline of the heating structure. The first thermopile may comprise a first plurality of thermocouples disposed upstream of the centerline of the heating structure. The first plurality of thermocouples may comprise a first subset of the first plurality of thermocouples aligned substantially parallel to the centerline of the heating structure. The first plurality of thermocouples may further comprise a second subset of the first plurality of thermocouples aligned substantially perpendicular to the centerline of the heating structure. The method may further comprise disposing a second thermopile downstream of the centerline of the heating structure. The second thermopile may comprise a second plurality of thermocouples disposed downstream of the centerline of the heating structure. The second plurality of thermocouples may comprise a third subset of the second plurality of thermocouples aligned substantially parallel to the centerline of the heating structure. The second plurality of thermocouples may further comprise a fourth subset of the second plurality of thermocouples aligned substantially perpendicular to the centerline of the heating structure.

The above summary is provided merely for purposes of summarizing some example embodiments to provide a basic understanding of some aspects of the disclosure. Accordingly, it will be appreciated that the above-described embodiments are merely examples and should not be construed to narrow the scope or spirit of the disclosure in any way. It will be appreciated that the scope of the disclosure encompasses many potential embodiments in addition to those here summarized, some of which will be further described below.

BRIEF DESCRIPTION OF THE DRAWINGS

Having described certain example embodiments of the present disclosure in general terms above, reference will now be made to the accompanying drawings, which illustrate example embodiments and features of the present disclosure and are not necessarily drawn to scale. It will be understood that the components and structures illustrated in the drawings may or may not be present in various embodiments of the disclosure described herein. Accordingly, some embodiments or features of the present disclosure may include fewer or more components or structures than those shown in the drawings while not departing from the scope of the disclosure.

FIG. 1 illustrates an example layout for an example thermopile-based flow sensing device in accordance with some example embodiments described herein.

FIGS. 2A and 2B illustrate example temperature isolines for an example thermopile-based flow sensing device in accordance with some example embodiments described herein.

FIG. 3 illustrates another example layout for an example thermopile-based flow sensing device in accordance with some example embodiments described herein.

FIG. 4 illustrates another example layout for an example thermopile-based flow sensing device in accordance with some example embodiments described herein.

FIG. 5 illustrates another example layout for an example thermopile-based flow sensing device in accordance with some example embodiments described herein.

FIG. 6 illustrates another example layout for an example thermopile-based flow sensing device in accordance with some example embodiments described herein.

FIG. 7 illustrates another example layout for an example thermopile-based flow sensing device in accordance with some example embodiments described herein.

FIG. 8 illustrates another example layout for an example thermopile-based flow sensing device in accordance with some example embodiments described herein.

FIGS. 9A, 9B, 9C, 9D, 9E, 9F, 9G, 9H, 9I, 9J, 9K, 9L, 9M, 9N, 9O, 9P, 9Q, 9R, 9S, and 9T illustrate an example process flow for fabricating an example thermopile-based flow sensing device in accordance with some example embodiments described herein.

FIG. 10 illustrates another example layout for an example thermopile-based flow sensing device in accordance with some example embodiments described herein.

FIG. 11 illustrates an example table of thermocouple materials for use in an example thermopile-based flow sensing device in accordance with some example embodiments described herein.

FIG. 12 illustrates an example flowchart illustrating an example method in accordance with some example embodiments described herein.

FIG. 13 illustrates an example flowchart illustrating another example method in accordance with some example embodiments described herein.

DETAILED DESCRIPTION

The following description should be read with reference to the drawings wherein like reference numerals indicate like elements throughout the several views. The detailed description and drawings show several embodiments which are meant to be illustrative of the disclosure. It should be understood that any numbering of disclosed features (e.g., first, second, etc.) and/or directional terms used in conjunction with disclosed features (e.g., front, back, under, above, etc.) are relative terms indicating illustrative relationships between the pertinent features. The word "example," when used herein, is intended to mean "serving as an example, instance, or illustration." Any implementation described herein as an "example" is not necessarily preferred or advantageous over other implementations.

It should be understood at the outset that although illustrative implementations of one or more aspects are illustrated below, the disclosed assemblies, systems, and methods may be implemented using any number of techniques. The disclosure should in no way be limited to the illustrative implementations, drawings, and techniques illustrated below, but may be modified within the scope of the appended claims along with their full scope of equivalents. While values for dimensions of various elements are disclosed, the drawings may not be to scale.

Typically, hot wire anemometer flow sensor die outputs drift while powered. In these hot wire anemometer flow sensors, which typically use platinum as the resistor material, the drift in the sensor is due to stress relaxation in the

platinum layer and changes in stress in the silicon nitride layers around the platinum which form the air bridge, in part because platinum has piezo-resistive properties whose resistance changes with stress. In other words, the drift in these hot wire anemometer flow sensors often is due to stress relaxation in the platinum layer and is impacted by the residual stress in the air bridge (also known as the micro-bridge). For example, drift has been directly correlated to the stress in the plasma enhanced chemical vapor deposition (PECVD) silicon nitride layer on the surface of the micro-bridge. This stress in the PECVD silicon nitride layer can change over time since the air bridge is constantly heated by a resistive heater, which is an integral part of the flow sensor. Experimentally, this drift has been measured at values up to about 40 uV per day at null flow. Accordingly, there is a need for a flow sensor that can be used with gases and liquids that exhibits low drift characteristics.

Example embodiments described herein provide systems, apparatuses, and methods for reducing or eliminating the drift experienced by conventional flow sensors by providing various arrangements for a thermopile-based flow sensing device. In some embodiments, by using a thermocouple or thermopile, the signal generated by the thermopile-based flow sensing device disclosed herein is a voltage source and is minimally responsive to film resistance. Without film resistance sensitivity, other sensitivities such as stress or magnetic resistance changes are negligible. Additional thermocouples give additional voltage, signal, and sensitivity, whereas a conventional resistive flow sensor does not have this advantage for sensitivity. In some instances, the thermopile structures may be fabricated on either a microbridge structure or a membrane structure. In some embodiments, the membrane structures disclosed herein may provide for the same thermopile structures as a microbridge plus additional structures not possible with a microbridge.

In some embodiments, the general flow for fabricating a thermopile flow sensor is as follows:

1. Grow thermal silicon dioxide.
2. Deposit bottom silicon nitride. In some embodiments, all silicon nitride dielectrics could be replaced with silicon dioxide, such as PECVD, tetraethoxysilane (TEOS), or sputter depositions for lower thermal conductivity.
3. Deposit and pattern resistive heater structure. The heater structure can be fabricated from, among other materials: silicon (including polysilicon); Pt; nichrome; permalloy; PtSi and other silicides; W; TiN; AN; WN; any other suitable material; or any combination thereof.
4. Deposit silicon nitride interlayer dielectric.
5. Deposit and pattern first thermocouple material. Various thermocouple materials that may be used for the first thermocouple are discussed in greater detail with reference to FIG. 11.
6. Deposit interlayer dielectric. In some instances, this step may be optional depending on the materials used but may lead to higher yield. In some instances, if an interlayer dielectric is used it must be patterned to open vias to the underlying thermocouple material.
7. Deposit and pattern second thermocouple material. Various thermocouple materials that may be used for the second thermocouple are discussed in greater detail with reference to FIG. 11.
8. Deposit interlayer dielectric, pattern, and open vias to heater and thermopile connections.
9. Deposit metal (such as Al/1% Cu) and pattern to form lead-outs and bond pads.
10. Deposit overcoat silicon nitride and pattern to open bond pad regions.

11. Pattern back-side of wafer and use deep reactive ion etching (DRIE) to produce cavity below thermopile structure.

In some embodiments, as discussed with reference to FIGS. 1, 2, 3, 4, 5, 6, 9, 10, and 12, the heater structure may be located below a single set of thermocouples (e.g., one thermopile) with one side located upstream of the heater structure and the other side located downstream of the heater structure. In these arrangements, the thermocouples do not sit on the silicon die. Rather, the thermocouples are suspended over a cavity or reside on a membrane structure. In some embodiments, the set of thermocouples may be collectively referred to as a thermopile. In some embodiments, the thermopile may be placed on a thermally isolated structure, such as a bridge or a membrane, with the opposing thermocouples (e.g., cold junction, hot junction) oriented such that one set of junctions are upstream and the other set of junctions is downstream of the centerline of a heating element.

In some embodiments, as discussed with reference to FIGS. 7, 8, and 13 the heater structure may be located between two sets of thermocouples (e.g., two thermopiles), with one set of thermocouples located upstream of the heater structure and the other set of thermocouples located downstream of the heater structure. In these arrangements, there are parasitics and each set of thermocouples has one side on the bulk silicon die, which can float in temperature.

In some embodiments, the following equation may be used to characterize the thermopile-based flow sensing devices disclosed herein:

$$\Delta V = n \Delta S (\Delta T)$$

where ΔV =potential difference; n =the number of thermocouples; S =Seebeck coefficient (also referred to as thermopower, thermoelectric power (TE), or thermoelectric sensitivity); ΔS = $TE_1 - TE_2$ (the thermoelectric power of the first thermoelectric material—the thermoelectric power of the second thermoelectric material); T =temperature; and $\Delta T = T_1 - T_{ref}$ (the temperature at the measured thermoelectric junction(s)—the temperature at the reference thermoelectric junction(s)). In some instances, such as is shown in FIG. 7, T_1 may be measured on the membrane structure 716 using the downstream thermocouple junctions 712, and may be measured on the bulk silicon using the downstream thermocouple junctions 713. In other instances, such as is shown in FIG. 6, the relative temperature difference ΔT may be measured on the membrane structure 716 using the upstream thermocouple junctions 608 and the downstream thermocouple junctions 610 without the use of a reference temperature.

There are many advantages of the embodiments disclosed herein, such as: (1) providing low drift or no drift devices (e.g., as discussed with reference to FIGS. 1, 2, 3, 4, 5, 6, 7, 8, 9, 10, 12, and 13); (2) providing potential compatibility with CMOS processing via unique combinations of thermocouple materials (e.g., as discussed with reference to FIG. 11).

Although the disclosure describes the features of the thermopile-based flow sensing device disclosed herein with reference to a flow sensor, the thermopile-based flow sensing device disclosed herein may be used to test in any suitable sensor, detector, gauge, instrument, or application where precision heating or temperature detection is utilized, utilizable, or otherwise desirable.

FIG. 1 illustrates an example layout for an example thermopile-based flow sensing device 100 in accordance with some example embodiments described herein. In some

embodiments, the example thermopile-based flow sensing device 100 may be provided for sensing a flow of fluid 101 (e.g., a flow of a gas or liquid). In some embodiments, the example thermopile-based flow sensing device 100 may comprise a heating structure 102 having a centerline 104. In some embodiments, the example thermopile-based flow sensing device 100 may further comprise a thermopile 106. In some embodiments, at least a portion of the thermopile 106 may be disposed over the heating structure 102.

In some embodiments, the thermopile 106 may comprise a plurality of thermocouples having a plurality of thermocouple junctions. In some embodiments, the plurality of thermocouples may have a plurality of upstream thermocouple junctions 108 (e.g., nineteen upstream thermocouple junctions) disposed upstream of the centerline 104 of the heating structure 102. In some embodiments, the plurality of thermocouples may have a plurality of downstream thermocouple junctions 110 (e.g., nineteen downstream thermocouple junctions) disposed downstream of the centerline 104 of the heating structure 102. In some embodiments, the plurality of upstream thermocouple junctions 108 and the plurality of downstream thermocouple junctions 110 may be disposed over the heating structure 102. In some embodiments, the number of upstream thermocouple junctions 108 and the number of downstream thermocouple junctions 110 may be the same. In some embodiments, the number of upstream thermocouple junctions 108 and the number of downstream thermocouple junctions 110 may depend (e.g., may be a function of) the Seebeck coefficients of the thermocouple materials in the thermocouples and the desired output voltage.

In some embodiments, the example thermopile-based flow sensing device 100 may further comprise a plurality of upstream sample temperature sensing thermocouple junctions 112 (e.g., two upstream sample temperature sensing thermocouple junctions) disposed upstream of the centerline 104 of the heating structure 102. In some embodiments, the example thermopile-based flow sensing device 100 may further comprise a plurality of downstream sample temperature sensing thermocouple junctions 114 (e.g., two downstream sample temperature sensing thermocouple junctions) disposed downstream of the centerline 104 of the heating structure 102. In some embodiments, the plurality of upstream sample temperature sensing thermocouple junctions 112 and the plurality of downstream sample temperature sensing thermocouple junctions 114 may be disposed over the heating structure 102.

In some embodiments, each of the plurality of upstream thermocouple junctions 108, the plurality of downstream thermocouple junctions 110, the plurality of upstream sample temperature sensing thermocouple junctions 112, and the plurality of downstream sample temperature sensing thermocouple junctions 114 may comprise a respective interface between a first thermocouple material and a second thermocouple material as described in greater detail with reference to FIG. 11.

In some embodiments, as shown in FIG. 1, the example thermopile-based flow sensing device 100 may comprise a substrate defining a membrane structure 116. In some embodiments, a portion of the heating structure 102 may be disposed over the membrane structure 116. In some embodiments, the thermopile 106, the plurality of thermocouples, the plurality of upstream thermocouple junctions 108, the plurality of downstream thermocouple junctions 110, the plurality of upstream sample temperature sensing thermocouple junctions 112, the plurality of downstream sample temperature sensing thermocouple junctions 114, one or

more portions thereof, or a combination thereof may be disposed over the membrane structure **116**. In some embodiments, the membrane structure **116** may provide thermal isolation from the bulk (e.g., silicon) die, which may have a high thermal conductivity. In some embodiments, the shape of the membrane structure **116** may be rectangular, square, circular, oval, or any other suitable shape or combination thereof.

In other embodiments (not shown in FIG. **1** for the sake of brevity), the example thermopile-based flow sensing device **100** may comprise a substrate defining a microbridge structure. In some embodiments, a portion of the heating structure **102** may be disposed over the microbridge structure. In some embodiments, the thermopile **106**, the plurality of thermocouples, the plurality of upstream thermocouple junctions **108**, the plurality of downstream thermocouple junctions **110**, the plurality of upstream sample temperature sensing thermocouple junctions **112**, the plurality of downstream sample temperature sensing thermocouple junctions **114**, one or more portions thereof, or a combination thereof may be disposed over the microbridge structure.

FIG. **2A** illustrates example temperature isolines **220** (e.g., including, but not limited to, temperature isoline **220A**, maximum temperature difference isoline **220B** (the temperature isoline that extends through about the locations where the maximum temperature difference occurs), and temperature isoline **220C**) for an example thermopile-based flow sensing device **200** in accordance with some example embodiments described herein.

In some embodiments, as shown in FIGS. **2A** and **2B**, the example thermopile-based flow sensing device **200** may be provided for sensing a flow of fluid **201** (e.g., a flow of a gas or liquid). In some embodiments, the example thermopile-based flow sensing device **200** may comprise a heating structure **202** having a centerline **204** and an axis **205** arranged perpendicular to the centerline **204**. In some embodiments, the example thermopile-based flow sensing device **200** may further comprise a thermopile. In some embodiments, at least a portion of the thermopile may be disposed over the heating structure **202**.

In some embodiments, as shown in FIGS. **2A** and **2B**, the thermopile may comprise a plurality of thermocouples having a plurality of thermocouple junctions. In some embodiments, the plurality of thermocouples may have a plurality of upstream thermocouple junctions **208** (e.g., seventeen upstream thermocouple junctions) disposed upstream of the centerline **204** of the heating structure **202**. In some embodiments, the plurality of thermocouples may have a plurality of downstream thermocouple junctions **210** (e.g., seventeen downstream thermocouple junctions) disposed downstream of the centerline **204** of the heating structure **202**. In some embodiments, the number of upstream thermocouple junctions **208** and the number of downstream thermocouple junctions **210** may be the same. In some embodiments, the number of upstream thermocouple junctions **208** and the number of downstream thermocouple junctions **210** may depend (e.g., may be a function of) the Seebeck coefficients of the thermocouple materials in the thermocouples and the desired output voltage.

In some embodiments, as shown in FIGS. **2A** and **2B**, each of the plurality of upstream thermocouple junctions **208** and the plurality of downstream thermocouple junctions **210** may occur along a maximum temperature difference isoline **220B** (e.g., the temperature isoline that extends through about the minimum temperature difference location **222** and the maximum temperature difference location **224**), where the farthest upstream thermocouple junction of the

plurality of upstream thermocouple junctions **208** occurs at about a minimum temperature difference location **222**, and where the farthest downstream thermocouple junction of the plurality of downstream thermocouple junctions **210** occurs at about a maximum temperature difference location **224**, respectively. For example, a maximum temperature difference may be defined by a minimum temperature difference location **222** upstream of the centerline **204** and a maximum temperature difference located at a maximum temperature difference location **224** downstream of the centerline **204**. The plurality of upstream thermocouple junctions **208** may be disposed at about a plurality of locations on the maximum temperature difference isoline **220B**. In other words, the plurality of upstream thermocouple junctions **208** may be disposed upstream of the centerline **204** at about a first plurality of points on an upstream portion of the maximum temperature difference isoline **220B** that extends through the minimum temperature difference location **222**. The plurality of downstream thermocouple junctions **210** may be disposed downstream of the centerline **204** at about a second plurality of points on a downstream portion of the maximum temperature difference isoline **220B** that extends through the maximum temperature difference location **224**. In some embodiments, the plurality of upstream thermocouple junctions **208** and the plurality of downstream thermocouple junctions **210** may not be disposed over the heating structure **202**.

FIG. **2B** illustrates example minimum temperature isolines **223** disposed around the minimum temperature difference location **222**. FIG. **2B** further illustrates example maximum temperature isolines **225** disposed around the maximum temperature difference location **224**.

In some embodiments, as shown in FIGS. **2A** and **2B**, the minimum temperature difference location **222** may be located about 135 micrometers upstream of the centerline **204**. In some embodiments, as shown in FIGS. **2A** and **2B**, the maximum temperature difference location **224** may be about 137 micrometers downstream of the centerline **204**. The locations of the minimum temperature difference location **222** and the maximum temperature difference location **224** may change with changes in the membrane structure **216** (e.g., shape, thickness), heating structure **202** (e.g., shape, thickness, material(s)), voltage applied to the heating structure **202**, and other structures.

In some embodiments, each of the plurality of upstream thermocouple junctions **208** and the plurality of downstream thermocouple junctions **210** may comprise a respective interface between a first thermocouple material and a second thermocouple material as described in greater detail with reference to FIG. **11**.

In some embodiments, as shown in FIGS. **2A** and **2B**, the example thermopile-based flow sensing device **200** may comprise a substrate defining a membrane structure **216**. In some embodiments, a portion of the heating structure **202** may be disposed over the membrane structure **216**. In some embodiments, the thermopile, the plurality of thermocouples, the plurality of upstream thermocouple junctions **208**, the plurality of downstream thermocouple junctions **210**, one or more portions thereof, or a combination thereof may be disposed over the membrane structure **216**. In some embodiments, the membrane structure **216** may provide thermal isolation from the bulk (e.g., silicon) die, which may have a high thermal conductivity. In some embodiments, the shape of the membrane structure **216** may be rectangular, square, circular, oval, or any other suitable shape or combination thereof.

In other embodiments (not shown in FIG. 2A or FIG. 2B for the sake of brevity), the example thermopile-based flow sensing device **200** may comprise a substrate defining a microbridge structure. In some embodiments, a portion of the heating structure **202** may be disposed over the microbridge structure. In some embodiments, the thermopile, the plurality of thermocouples, the plurality of upstream thermocouple junctions **208**, the plurality of downstream thermocouple junctions **210**, one or more portions thereof, or a combination thereof may be disposed over the microbridge structure.

FIG. 3 illustrates an example layout for an example thermopile-based flow sensing device **300** in accordance with some example embodiments described herein. In some embodiments, the example thermopile-based flow sensing device **300** may be provided for sensing a flow of fluid **301** (e.g., a flow of a gas or liquid). In some embodiments, the example thermopile-based flow sensing device **300** may comprise a heating structure **302** having a centerline **304**. In some embodiments, the example thermopile-based flow sensing device **300** may further comprise a thermopile **306**. In some embodiments, at least a portion of the thermopile **306** may be disposed over the heating structure **302**.

In some embodiments, the thermopile **306** may comprise a plurality of thermocouples having a plurality of thermocouple junctions. In some embodiments, the plurality of thermocouples may have a plurality of upstream thermocouple junctions **308** (e.g., nineteen upstream thermocouple junctions) disposed upstream of the centerline **304** of the heating structure **302**. In some embodiments, the plurality of thermocouples may have a plurality of downstream thermocouple junctions **310** (e.g., nineteen downstream thermocouple junctions) disposed downstream of the centerline **304** of the heating structure **302**. In some embodiments, the plurality of upstream thermocouple junctions **308** and the plurality of downstream thermocouple junctions **310** may be disposed over the heating structure **302**. In some embodiments, the number of upstream thermocouple junctions **308** and the number of downstream thermocouple junctions **310** may be the same. In some embodiments, the number of upstream thermocouple junctions **308** and the number of downstream thermocouple junctions **310** may depend (e.g., may be a function of) the Seebeck coefficients of the thermocouple materials in the thermocouples and the desired output voltage.

In some embodiments, the example thermopile-based flow sensing device **300** may further comprise a plurality of upstream sample temperature sensing thermocouple junctions **312** (e.g., two upstream sample temperature sensing thermocouple junctions) disposed upstream of the centerline **304** of the heating structure **302**. In some embodiments, the example thermopile-based flow sensing device **300** may further comprise a plurality of downstream sample temperature sensing thermocouple junctions **314** (e.g., two downstream sample temperature sensing thermocouple junctions) disposed downstream of the centerline **304** of the heating structure **302**. In some embodiments, the plurality of upstream sample temperature sensing thermocouple junctions **312** and the plurality of downstream sample temperature sensing thermocouple junctions **314** may be disposed over the heating structure **302**.

In some embodiments, each of the plurality of upstream thermocouple junctions **308**, the plurality of downstream thermocouple junctions **310**, the plurality of upstream sample temperature sensing thermocouple junctions **312**, and the plurality of downstream sample temperature sensing thermocouple junctions **314** may comprise a respective

interface between a first thermocouple material and a second thermocouple material as described in greater detail with reference to FIG. 11.

In some embodiments, as shown in FIG. 3, the example thermopile-based flow sensing device **300** may comprise a substrate defining a membrane structure **316**. In some embodiments, a portion of the heating structure **302** may be disposed over the membrane structure **316**. In some embodiments, the thermopile **306**, the plurality of thermocouples, the plurality of upstream thermocouple junctions **308**, the plurality of downstream thermocouple junctions **310**, the plurality of upstream sample temperature sensing thermocouple junctions **312**, the plurality of downstream sample temperature sensing thermocouple junctions **314**, one or more portions thereof, or a combination thereof may be disposed over the membrane structure **316**. In some embodiments, the membrane structure **316** may provide thermal isolation from the bulk (e.g., silicon) die, which may have a high thermal conductivity. In some embodiments, the shape of the membrane structure **316** may be rectangular, square, circular, oval, or any other suitable shape or combination thereof.

In other embodiments (not shown in FIG. 3 for the sake of brevity), the example thermopile-based flow sensing device **300** may comprise a substrate defining a microbridge structure. In some embodiments, a portion of the heating structure **302** may be disposed over the microbridge structure. In some embodiments, the thermopile **306**, the plurality of thermocouples, the plurality of upstream thermocouple junctions **308**, the plurality of downstream thermocouple junctions **310**, the plurality of upstream sample temperature sensing thermocouple junctions **312**, the plurality of downstream sample temperature sensing thermocouple junctions **314**, one or more portions thereof, or a combination thereof may be disposed over the microbridge structure.

FIG. 4 illustrates an example layout for an example thermopile-based flow sensing device **400** in accordance with some example embodiments described herein. In some embodiments, the example thermopile-based flow sensing device **400** may be provided for sensing a flow of fluid **401** (e.g., a flow of a gas or liquid). In some embodiments, the example thermopile-based flow sensing device **400** may comprise a heating structure **402** having a centerline **404**. In some embodiments, the example thermopile-based flow sensing device **400** may further comprise a thermopile **406**. In some embodiments, at least a portion of the thermopile **406** may be disposed over the heating structure **402**.

In some embodiments, the thermopile **406** may comprise a plurality of thermocouples having a plurality of thermocouple junctions. In some embodiments, the plurality of thermocouples may have a plurality of upstream thermocouple junctions **408** (e.g., nineteen upstream thermocouple junctions) disposed upstream of the centerline **404** of the heating structure **402**. In some embodiments, the plurality of thermocouples may have a plurality of downstream thermocouple junctions **410** (e.g., nineteen downstream thermocouple junctions) disposed downstream of the centerline **404** of the heating structure **402**. In some embodiments, the plurality of upstream thermocouple junctions **408** and the plurality of downstream thermocouple junctions **410** may not be disposed over the heating structure **402**. In some embodiments, the number of upstream thermocouple junctions **408** and the number of downstream thermocouple junctions **410** may be the same. In some embodiments, the number of upstream thermocouple junctions **408** and the number of downstream thermocouple junctions **410** may

depend (e.g., may be a function of) the Seebeck coefficients of the thermocouple materials in the thermocouples and the desired output voltage.

In some embodiments, the example thermopile-based flow sensing device **400** may further comprise a plurality of upstream sample temperature sensing thermocouple junctions **412** (e.g., two upstream sample temperature sensing thermocouple junctions) disposed upstream of the centerline **404** of the heating structure **402**. In some embodiments, the example thermopile-based flow sensing device **400** may further comprise a plurality of downstream sample temperature sensing thermocouple junctions **414** (e.g., two downstream sample temperature sensing thermocouple junctions) disposed downstream of the centerline **404** of the heating structure **402**. In some embodiments, the plurality of upstream sample temperature sensing thermocouple junctions **412** and the plurality of downstream sample temperature sensing thermocouple junctions **414** may not be disposed over the heating structure **402**.

In some embodiments, each of the plurality of upstream thermocouple junctions **408**, the plurality of downstream thermocouple junctions **410**, the plurality of upstream sample temperature sensing thermocouple junctions **412**, and the plurality of downstream sample temperature sensing thermocouple junctions **414** may comprise a respective interface between a first thermocouple material and a second thermocouple material as described in greater detail with reference to FIG. **11**.

In some embodiments, as shown in FIG. **4**, the example thermopile-based flow sensing device **400** may comprise a substrate defining a membrane structure **416**. In some embodiments, a portion of the heating structure **402** may be disposed over the membrane structure **416**. In some embodiments, the thermopile **406**, the plurality of thermocouples, the plurality of upstream thermocouple junctions **408**, the plurality of downstream thermocouple junctions **410**, the plurality of upstream sample temperature sensing thermocouple junctions **412**, the plurality of downstream sample temperature sensing thermocouple junctions **414**, one or more portions thereof, or a combination thereof may be disposed over the membrane structure **416**. In some embodiments, the membrane structure **416** may provide thermal isolation from the bulk (e.g., silicon) die, which may have a high thermal conductivity. In some embodiments, the shape of the membrane structure **416** may be rectangular, square, circular, oval, or any other suitable shape or combination thereof.

In other embodiments (not shown in FIG. **4** for the sake of brevity), the example thermopile-based flow sensing device **400** may comprise a substrate defining a microbridge structure. In some embodiments, a portion of the heating structure **402** may be disposed over the microbridge structure. In some embodiments, the thermopile **406**, the plurality of thermocouples, the plurality of upstream thermocouple junctions **408**, the plurality of downstream thermocouple junctions **410**, the plurality of upstream sample temperature sensing thermocouple junctions **412**, the plurality of downstream sample temperature sensing thermocouple junctions **414**, one or more portions thereof, or a combination thereof may be disposed over the microbridge structure.

FIG. **5** illustrates an example layout for an example thermopile-based flow sensing device **500** in accordance with some example embodiments described herein. In some embodiments, the example thermopile-based flow sensing device **500** may be provided for sensing a flow of fluid **501** (e.g., a flow of a gas or liquid). In some embodiments, the example thermopile-based flow sensing device **500** may

comprise a heating structure **502** having a centerline **504**. In some embodiments, the example thermopile-based flow sensing device **500** may further comprise a thermopile **506**. In some embodiments, at least a portion of the thermopile **506** may be disposed over the heating structure **502**.

In some embodiments, the thermopile **506** may comprise a plurality of thermocouples having a plurality of thermocouple junctions. In some embodiments, the plurality of thermocouples may have a plurality of upstream thermocouple junctions **508** (e.g., nineteen upstream thermocouple junctions) disposed upstream of the centerline **504** of the heating structure **502**. In some embodiments, the plurality of thermocouples may have a plurality of downstream thermocouple junctions **510** (e.g., nineteen downstream thermocouple junctions) disposed downstream of the centerline **504** of the heating structure **502**. In some embodiments, the number of upstream thermocouple junctions **508** and the number of downstream thermocouple junctions **510** may be the same. In some embodiments, the number of upstream thermocouple junctions **508** and the number of downstream thermocouple junctions **510** may depend (e.g., may be a function of) the Seebeck coefficients of the thermocouple materials in the thermocouples and the desired output voltage.

In some embodiments, each of the plurality of upstream thermocouple junctions **508** and the plurality of downstream thermocouple junctions **510** may be aligned parallel to centerline **504** and occur along an upstream vertical line through about a minimum temperature difference location (e.g., minimum temperature difference location **222** shown in FIGS. **2A** and **2B**) and a downstream vertical line through about a maximum temperature difference location (e.g., maximum temperature difference location **224** shown in FIGS. **2A** and **2B**), respectively. For example, a maximum temperature difference may be defined by a minimum temperature difference located at a first location (e.g., minimum temperature difference location **222** shown in FIGS. **2A** and **2B**) upstream of the centerline **504** and a maximum temperature difference located at a second location (e.g., maximum temperature difference location **224** shown in FIGS. **2A** and **2B**) downstream of the centerline **504**; the plurality of upstream thermocouple junctions **508** may be disposed upstream of the centerline **504** at about a first plurality of points on a first line that extends through about the first location and is aligned substantially parallel to the centerline **504**; and the plurality of downstream thermocouple junctions **510** may be disposed downstream of the centerline **504** at about a second plurality of points on a second line that extends through about the second location and is aligned substantially parallel to the centerline **504**. In some embodiments, the plurality of upstream thermocouple junctions **508** and the plurality of downstream thermocouple junctions **510** may not be disposed over the heating structure **502**.

In some embodiments, the example thermopile-based flow sensing device **500** may further comprise a plurality of upstream sample temperature sensing thermocouple junctions **512** (e.g., two upstream sample temperature sensing thermocouple junctions) disposed upstream of the centerline **504** of the heating structure **502**. In some embodiments, the example thermopile-based flow sensing device **500** may further comprise a plurality of downstream sample temperature sensing thermocouple junctions **514** (e.g., two downstream sample temperature sensing thermocouple junctions) disposed downstream of the centerline **504** of the heating structure **502**. In some embodiments, the plurality of upstream sample temperature sensing thermocouple junctions **512** and the plurality of downstream sample tempera-

ture sensing thermocouple junctions **514** may not be disposed over the heating structure **502**.

In some embodiments, each of the plurality of upstream thermocouple junctions **508**, the plurality of downstream thermocouple junctions **510**, the plurality of upstream sample temperature sensing thermocouple junctions **512**, and the plurality of downstream sample temperature sensing thermocouple junctions **514** may comprise a respective interface between a first thermocouple material and a second thermocouple material as described in greater detail with reference to FIG. **11**.

In some embodiments, as shown in FIG. **5**, the example thermopile-based flow sensing device **500** may comprise a substrate defining a membrane structure **516**. In some embodiments, a portion of the heating structure **502** may be disposed over the membrane structure **516**. In some embodiments, the thermopile **506**, the plurality of thermocouples, the plurality of upstream thermocouple junctions **508**, the plurality of downstream thermocouple junctions **510**, the plurality of upstream sample temperature sensing thermocouple junctions **512**, the plurality of downstream sample temperature sensing thermocouple junctions **514**, one or more portions thereof, or a combination thereof may be disposed over the membrane structure **516**. In some embodiments, the membrane structure **516** may provide thermal isolation from the bulk (e.g., silicon) die, which may have a high thermal conductivity. In some embodiments, the shape of the membrane structure **516** may be rectangular, square, circular, oval, or any other suitable shape or combination thereof.

In other embodiments (not shown in FIG. **5** for the sake of brevity), the example thermopile-based flow sensing device **500** may comprise a substrate defining a microbridge structure. In some embodiments, a portion of the heating structure **502** may be disposed over the microbridge structure. In some embodiments, the thermopile **506**, the plurality of thermocouples, the plurality of upstream thermocouple junctions **508**, the plurality of downstream thermocouple junctions **510**, the plurality of upstream sample temperature sensing thermocouple junctions **512**, the plurality of downstream sample temperature sensing thermocouple junctions **514**, one or more portions thereof, or a combination thereof may be disposed over the microbridge structure.

FIG. **6** illustrates an example layout for an example thermopile-based flow sensing device **600** in accordance with some example embodiments described herein. In some embodiments, the example thermopile-based flow sensing device **600** may be provided for sensing a flow of fluid **601** (e.g., a flow of a gas or liquid). In some embodiments, the example thermopile-based flow sensing device **600** may comprise a heating structure **602** having a centerline **604**. In some embodiments, the example thermopile-based flow sensing device **600** may further comprise a thermopile **606**. In some embodiments, at least a portion of the thermopile **606** may be disposed over the heating structure **602**.

In some embodiments, the thermopile **606** may comprise a plurality of thermocouples having a plurality of thermocouple junctions. In some embodiments, the plurality of thermocouples may have a plurality of upstream thermocouple junctions **608** (e.g., nineteen upstream thermocouple junctions) disposed upstream of the centerline **604** of the heating structure **602**. In some embodiments, the plurality of thermocouples may have a plurality of downstream thermocouple junctions **610** (e.g., nineteen downstream thermocouple junctions) disposed downstream of the centerline **604** of the heating structure **602**. In some embodiments, the number of upstream thermocouple junctions **608** and the

number of downstream thermocouple junctions **610** may be the same. In some embodiments, the number of upstream thermocouple junctions **608** and the number of downstream thermocouple junctions **610** may depend (e.g., may be a function of) the Seebeck coefficients of the thermocouple materials in the thermocouples and the desired output voltage.

In some embodiments, each of the plurality of upstream thermocouple junctions **608** and the plurality of downstream thermocouple junctions **610** may occur along a maximum temperature difference isoline (e.g., maximum temperature difference isoline **220B** shown in FIGS. **2A** and **2B**), where the farthest upstream thermocouple junction of the plurality of upstream thermocouple junctions **608** occurs at about a minimum temperature difference location (e.g., minimum temperature difference location **222** shown in FIGS. **2A** and **2B**), and where the farthest downstream thermocouple junction of the plurality of downstream thermocouple junctions **610** occurs at about a maximum temperature difference location (e.g., maximum temperature difference location **224** shown in FIGS. **2A** and **2B**), respectively. For example, a maximum temperature difference may be defined by a minimum temperature difference located at a first location (e.g., minimum temperature difference location **222** shown in FIGS. **2A** and **2B**) upstream of the centerline **604** and a maximum temperature difference located at a second location (e.g., maximum temperature difference location **224** shown in FIGS. **2A** and **2B**) downstream of the centerline **604**; and the plurality of upstream thermocouple junctions **608** may be disposed at about a plurality of locations on a maximum temperature difference isoline (e.g., maximum temperature difference isoline **220B** shown in FIGS. **2A** and **2B**). In other words, the plurality of upstream thermocouple junctions **608** may be disposed upstream of the centerline **604** at about a first plurality of points on a first portion (e.g., an upstream portion) of a maximum temperature difference isoline that extends through the first location; and the plurality of downstream thermocouple junctions **610** may be disposed downstream of the centerline **604** at about a second plurality of points on a second portion (e.g., a downstream portion) of the maximum temperature difference isoline that extends through the second location. In some embodiments, the plurality of upstream thermocouple junctions **608** and the plurality of downstream thermocouple junctions **610** may not be disposed over the heating structure **602**.

In some embodiments, the example thermopile-based flow sensing device **600** may further comprise a plurality of upstream sample temperature sensing thermocouple junctions **612** (e.g., two upstream sample temperature sensing thermocouple junctions) disposed upstream of the centerline **604** of the heating structure **602**. In some embodiments, the example thermopile-based flow sensing device **600** may further comprise a plurality of downstream sample temperature sensing thermocouple junctions **614** (e.g., two downstream sample temperature sensing thermocouple junctions) disposed downstream of the centerline **604** of the heating structure **602**. In some embodiments, the plurality of upstream sample temperature sensing thermocouple junctions **612** and the plurality of downstream sample temperature sensing thermocouple junctions **614** may not be disposed over the heating structure **602**.

In some embodiments, each of the plurality of upstream thermocouple junctions **608**, the plurality of downstream thermocouple junctions **610**, the plurality of upstream sample temperature sensing thermocouple junctions **612**, and the plurality of downstream sample temperature sensing thermocouple junctions **614** may comprise a respective

interface between a first thermocouple material and a second thermocouple material as described in greater detail with reference to FIG. 11.

In some embodiments, as shown in FIG. 6, the example thermopile-based flow sensing device 600 may comprise a substrate defining a membrane structure 616. In some embodiments, a portion of the heating structure 602 may be disposed over the membrane structure 616. In some embodiments, the thermopile 606, the plurality of thermocouples, the plurality of upstream thermocouple junctions 608, the plurality of downstream thermocouple junctions 610, the plurality of upstream sample temperature sensing thermocouple junctions 612, the plurality of downstream sample temperature sensing thermocouple junctions 614, one or more portions thereof, or a combination thereof may be disposed over the membrane structure 616. In some embodiments, the membrane structure 616 may provide thermal isolation from the bulk (e.g., silicon) die, which may have a high thermal conductivity. In some embodiments, the shape of the membrane structure 616 may be rectangular, square, circular, oval, or any other suitable shape or combination thereof.

In other embodiments (not shown in FIG. 6 for the sake of brevity), the example thermopile-based flow sensing device 600 may comprise a substrate defining a microbridge structure. In some embodiments, a portion of the heating structure 602 may be disposed over the microbridge structure. In some embodiments, the thermopile 606, the plurality of thermocouples, the plurality of upstream thermocouple junctions 608, the plurality of downstream thermocouple junctions 610, the plurality of upstream sample temperature sensing thermocouple junctions 612, the plurality of downstream sample temperature sensing thermocouple junctions 614, one or more portions thereof, or a combination thereof may be disposed over the microbridge structure.

FIG. 7 illustrates an example layout for an example thermopile-based flow sensing device 700 in accordance with some example embodiments described herein. In some embodiments, the example thermopile-based flow sensing device 700 may be provided for sensing a flow of fluid 701 (e.g., a flow of a gas or liquid). In some embodiments, the example thermopile-based flow sensing device 700 may comprise a heating structure 702 having a centerline 704. In some embodiments, the example thermopile-based flow sensing device 700 may further comprise a first thermopile 706 and a second thermopile 710.

In some embodiments, the first thermopile 706 may comprise a plurality of upstream thermocouples having a first plurality of upstream thermocouple junctions 708 (e.g., nineteen upstream thermocouple junctions) disposed upstream of the centerline 704 of the heating structure 702 and a second plurality of upstream thermocouple junctions 709 (e.g., nineteen upstream thermocouple junctions) disposed further upstream of the centerline 704 of the heating structure 702. In some embodiments, the number of the first plurality of upstream thermocouple junctions 708 and the number of the second plurality of upstream thermocouple junctions 709 may be the same. In some embodiments, the number of the first plurality of upstream thermocouple junctions 708 and the number of the second plurality of upstream thermocouple junctions 709 may depend (e.g., may be a function of) the Seebeck coefficients of the thermocouple materials in the thermocouples and the desired output voltage.

In some embodiments, the first plurality of upstream thermocouple junctions 708 and the second plurality of upstream thermocouple junctions 709 may not be disposed

over the heating structure 702. For example, a maximum temperature difference may be defined by a minimum temperature difference located at a first location (e.g., minimum temperature difference location 222 shown in FIGS. 2A and 2B) upstream of the centerline 704 and a maximum temperature difference located at a second location (e.g., maximum temperature difference location 224 shown in FIGS. 2A and 2B) downstream of the centerline 704; the first plurality of upstream thermocouple junctions 708 may be disposed upstream of the centerline 704 at about a first plurality of points on a first line that extends through about the first location and is aligned substantially parallel to the centerline 704; and the second plurality of upstream thermocouple junctions 709 may be disposed further upstream of the centerline 704 at about a second plurality of points on a second line that is aligned substantially parallel to the centerline 704.

In some embodiments, the second thermopile 710 may comprise a plurality of downstream thermocouples having a first plurality of downstream thermocouple junctions 712 (e.g., nineteen downstream thermocouple junctions) disposed downstream of the centerline 704 of the heating structure 702 and a second plurality of downstream thermocouple junctions 713 (e.g., nineteen downstream thermocouple junctions) disposed further downstream of the centerline 704 of the heating structure 702. In some embodiments, the number of the first plurality of downstream thermocouple junctions 712 and the number of the second plurality of downstream thermocouple junctions 713 may be the same. In some embodiments, the number of the first plurality of downstream thermocouple junctions 712 and the number of the second plurality of downstream thermocouple junctions 713 may depend (e.g., may be a function of) the Seebeck coefficients of the thermocouple materials in the thermocouples and the desired output voltage.

In some embodiments, each of the first plurality of upstream thermocouple junctions 708 and the first plurality of downstream thermocouple junctions 712 may be aligned parallel to centerline 704 and occur along an upstream vertical line through about a minimum temperature difference location (e.g., minimum temperature difference location 222 shown in FIGS. 2A and 2B) and a downstream vertical line through about a maximum temperature difference location (e.g., maximum temperature difference location 224 shown in FIGS. 2A and 2B), respectively. For example, a maximum temperature difference may be defined by a minimum temperature difference located at a first location (e.g., minimum temperature difference location 222 shown in FIGS. 2A and 2B) upstream of the centerline 704 and a maximum temperature difference located at a second location (e.g., maximum temperature difference location 224 shown in FIGS. 2A and 2B) downstream of the centerline 704; the first plurality of downstream thermocouple junctions 712 may be disposed downstream of the centerline 704 at about a third plurality of points on a third line that extends through about the second location and is aligned substantially parallel to the centerline 704; and the second plurality of downstream thermocouple junctions may be disposed further downstream of the centerline 704 at about a fourth plurality of points on a fourth line that is aligned substantially parallel to the centerline 704. In some embodiments, the first plurality of downstream thermocouple junctions 712 and the second plurality of downstream thermocouple junctions may not be disposed over the heating structure 702.

In some embodiments, each of the first plurality of upstream thermocouple junctions 708, the second plurality

of upstream thermocouple junctions **709**, the first plurality of downstream thermocouple junctions **712**, the second plurality of downstream thermocouple junctions **713**, the plurality of upstream sample temperature sensing thermocouple junctions, and the plurality of downstream sample temperature sensing thermocouple junctions may comprise a respective interface between a first thermocouple material and a second thermocouple material as described in greater detail with reference to FIG. **11**.

In some embodiments, as shown in FIG. **7**, the example thermopile-based flow sensing device **700** may comprise a substrate defining a membrane structure **716**. In some embodiments, a portion of the heating structure **702** may be disposed over the membrane structure **716**. In some embodiments, the first thermopile **706**, the plurality of upstream thermocouples, the first plurality of upstream thermocouple junctions **708**, the second plurality of upstream thermocouple junctions **709**, the second thermopile **710**, the plurality of downstream thermocouples, the first plurality of downstream thermocouple junctions **712**, the second plurality of downstream thermocouple junctions **713**, the plurality of upstream sample temperature sensing thermocouple junctions, the plurality of downstream sample temperature sensing thermocouple junctions, one or more portions thereof, or a combination thereof may be disposed over the membrane structure **716**. For example, as shown in FIG. **7**, a portion of the first thermopile **706** may be disposed over the membrane structure **716** such that the first plurality of upstream thermocouple junctions **708** may be disposed over the membrane structure **716** and the second plurality of upstream thermocouple junctions **709** may not be disposed over the membrane structure **716**. In another example, as shown in FIG. **7**, a portion of the second thermopile **710** may be disposed over the membrane structure **716** such that the first plurality of downstream thermocouple junctions **712** may be disposed over the membrane structure **716** and the second plurality of downstream thermocouple junctions **713** may not be disposed over the membrane structure **716**. In some embodiments, the membrane structure **716** may provide thermal isolation from the bulk (e.g., silicon) die, which may have a high thermal conductivity. In some embodiments, the shape of the membrane structure **716** may be rectangular, square, circular, oval, or any other suitable shape or combination thereof.

FIG. **8** illustrates an example layout for an example thermopile-based flow sensing device **800** in accordance with some example embodiments described herein. In some embodiments, the example thermopile-based flow sensing device **800** may be provided for sensing a flow of fluid **801** (e.g., a flow of a gas or liquid). In some embodiments, the example thermopile-based flow sensing device **800** may comprise a heating structure **802** having a centerline **804** and an axis **805** arranged perpendicular to the centerline **804**. In some embodiments, the example thermopile-based flow sensing device **800** may further comprise a first thermopile **806** and a second thermopile **826**.

In some embodiments, the first thermopile **806** may comprise a plurality of upstream thermocouples disposed upstream of the centerline **804** of the heating structure **802**. In some embodiments, the plurality of upstream thermocouples may comprise a first subset of the plurality of upstream thermocouples aligned substantially parallel to the centerline **804** of the heating structure **802**, such as a first plurality of upstream parallel thermocouples **808** having a first plurality of upstream thermocouple junctions **810** (e.g., six thermocouple junctions) and a second plurality of upstream thermocouple junctions **812** (e.g., seven thermo-

couple junctions). In some embodiments, the plurality of upstream thermocouples may further comprise a second subset of the plurality of upstream thermocouples aligned substantially perpendicular to the centerline **804** of the heating structure **802**, such as a plurality of upstream perpendicular thermocouples **814** having a third plurality of upstream thermocouple junctions **816** (e.g., eleven thermocouple junctions) and a fourth plurality of upstream thermocouple junctions **818** (e.g., twelve thermocouple junctions). In some embodiments, the plurality of upstream thermocouples may comprise a third subset of the plurality of upstream thermocouples aligned substantially parallel to the centerline **804** of the heating structure **802**, such as a second plurality of upstream parallel thermocouples **820** having a fifth plurality of upstream thermocouple junctions **822** (e.g., six thermocouple junctions) and a sixth plurality of upstream thermocouple junctions **824** (e.g., six thermocouple junctions). In some embodiments, the first thermopile **806** may not be disposed over the heating structure **802**. In some embodiments, the number of the first plurality of upstream thermocouple junctions **810**, the number of the second plurality of upstream thermocouple junctions **812**, the number of the third plurality of upstream thermocouple junctions **816**, the number of the fourth plurality of upstream thermocouple junctions **818**, the number of the fifth plurality of upstream thermocouple junctions **822**, and the number of the sixth plurality of upstream thermocouple junctions **824** may depend (e.g., may be a function of) the Seebeck coefficients of the thermocouple materials in the thermocouples and the desired output voltage.

In some embodiments, the second thermopile **826** may comprise a plurality of downstream thermocouples disposed downstream of the centerline **804** of the heating structure **802**. In some embodiments, the plurality of downstream thermocouples may comprise a first subset of the plurality of downstream thermocouples aligned substantially parallel to the centerline **804** of the heating structure **802**, such as a first plurality of downstream parallel thermocouples **828** having a first plurality of downstream thermocouple junctions **830** (e.g., six thermocouple junctions) and a second plurality of downstream thermocouple junctions **832** (e.g., seven thermocouple junctions). In some embodiments, the plurality of downstream thermocouples may further comprise a second subset of the plurality of downstream thermocouples aligned substantially perpendicular to the centerline **804** of the heating structure **802**, such as a plurality of downstream perpendicular thermocouples **834** having a third plurality of downstream thermocouple junctions **836** (e.g., eleven thermocouple junctions) and a fourth plurality of downstream thermocouple junctions **838** (e.g., twelve thermocouple junctions). In some embodiments, the plurality of downstream thermocouples may comprise a third subset of the plurality of downstream thermocouples aligned substantially parallel to the centerline **804** of the heating structure **802**, such as a second plurality of downstream parallel thermocouples **840** having a fifth plurality of downstream thermocouple junctions **842** (e.g., six thermocouple junctions) and a sixth plurality of downstream thermocouple junctions **844** (e.g., six thermocouple junctions). In some embodiments, the second thermopile **826** may not be disposed over the heating structure **802**. In some embodiments, the number of the first plurality of downstream thermocouple junctions **830**, the number of the second plurality of downstream thermocouple junctions **832**, the number of the third plurality of downstream thermocouple junctions **836**, the number of the fourth plurality of downstream thermocouple junctions **838**, the number of the fifth plurality of downstream

thermocouple junctions **842**, and the number of the sixth plurality of downstream thermocouple junctions **844** may depend (e.g., may be a function of) the Seebeck coefficients of the thermocouple materials in the thermocouples and the desired output voltage.

In some embodiments, each of the second plurality of upstream thermocouple junctions **812**, the fourth plurality of upstream thermocouple junctions **818**, the sixth plurality of upstream thermocouple junctions **824**, the second plurality of downstream thermocouple junctions **832**, the fourth plurality of downstream thermocouple junctions **838**, and the sixth plurality of downstream thermocouple junctions **844** may be disposed above the bulk substrate (e.g., bulk silicon) and may be at the same temperature and thus serve as a reference for measurements.

In some embodiments, each of the first plurality of upstream thermocouple junctions **810**, the second plurality of upstream thermocouple junctions **812**, the third plurality of upstream thermocouple junctions **816**, the fourth plurality of upstream thermocouple junctions **818**, the fifth plurality of upstream thermocouple junctions **822**, the sixth plurality of upstream thermocouple junctions **824**, the first plurality of downstream thermocouple junctions **830**, the second plurality of downstream thermocouple junctions **832**, the third plurality of downstream thermocouple junctions **836**, the fourth plurality of downstream thermocouple junctions **838**, the fifth plurality of downstream thermocouple junctions **842**, and the sixth plurality of downstream thermocouple junctions **844** may comprise a respective interface between a first thermocouple material and a second thermocouple material as described in greater detail with reference to FIG. **11**.

In some embodiments, as shown in FIG. **8**, the example thermopile-based flow sensing device **800** may comprise a substrate defining a membrane structure **856**. In some embodiments, a portion of the heating structure **802** may be disposed over the membrane structure **856**. In some embodiments, the plurality of upstream thermocouples, the first subset of the plurality of upstream thermocouples, the first plurality of upstream parallel thermocouples **808**, the first plurality of upstream thermocouple junctions **810**, the second plurality of upstream thermocouple junctions **812**, the second subset of the plurality of upstream thermocouples, the plurality of upstream perpendicular thermocouples **814**, the third plurality of upstream thermocouple junctions **816**, the fourth plurality of upstream thermocouple junctions **818**, the third subset of the plurality of upstream thermocouples, the second plurality of upstream parallel thermocouples **820**, the fifth plurality of upstream thermocouple junctions **822**, the sixth plurality of upstream thermocouple junctions **824**, the second thermopile **826**, the plurality of downstream thermocouples, the first subset of the plurality of downstream thermocouples, the first plurality of downstream parallel thermocouples **828**, the first plurality of downstream thermocouple junctions **830**, the second plurality of downstream thermocouple junctions **832**, the second subset of the plurality of downstream thermocouples, the downstream perpendicular thermocouples **834**, the third plurality of downstream thermocouple junctions **836**, the fourth plurality of downstream thermocouple junctions **838**, the third subset of the plurality of downstream thermocouples, the second plurality of downstream parallel thermocouples **840**, the fifth plurality of downstream thermocouple junctions **842**, the sixth plurality of downstream thermocouple junctions **844**, one or more portions thereof, or a combination thereof may be disposed over the membrane structure **856**. For example, as shown in FIG. **8**, a portion of the first

thermopile **806** may be disposed over the membrane structure **856** such that: the first plurality of upstream thermocouple junctions **810** may be disposed over the membrane structure **856**, and the second plurality of upstream thermocouple junctions **812** may not be disposed over the membrane structure **856**; the third plurality of upstream thermocouple junctions **816** may be disposed over the membrane structure **856**, and the fourth plurality of upstream thermocouple junctions **818** may not be disposed over the membrane structure **856**; and the fifth plurality of upstream thermocouple junctions **822** may be disposed over the membrane structure **856**, and the sixth plurality of upstream thermocouple junctions **824** may not be disposed over the membrane structure **856**. In another example, as shown in FIG. **8**, a portion of the second thermopile **826** may be disposed over the membrane structure **856** such that: the first plurality of downstream thermocouple junctions **830** may be disposed over the membrane structure **856**, and the second plurality of downstream thermocouple junctions **832** may not be disposed over the membrane structure **856**; the third plurality of downstream thermocouple junctions **836** may be disposed over the membrane structure **856**, and the fourth plurality of downstream thermocouple junctions **838** may not be disposed over the membrane structure **856**; and the fifth plurality of downstream thermocouple junctions **842** may be disposed over the membrane structure **856**, and the sixth plurality of downstream thermocouple junctions **844** may not be disposed over the membrane structure **856**. In some embodiments, the membrane structure **856** may provide thermal isolation from the bulk (e.g., silicon) die, which may have a high thermal conductivity. In some embodiments, the shape of the membrane structure **856** may be rectangular, square, circular, oval, or any other suitable shape or combination thereof.

FIGS. **9A**, **9B**, **9C**, **9D**, **9E**, **9F**, **9G**, **9H**, **9I**, **9J**, **9K**, **9L**, **9M**, **9N**, **9O**, **9P**, **9Q**, **9R**, **9S**, and **9T** illustrate an example process flow for fabricating an example thermopile-based flow sensing device in accordance with some example embodiments described herein.

As shown in FIG. **9A**, at step **900** the process flow may begin with fabricating (e.g., by thermal oxidation) a silicon dioxide (SiO₂) layer **932A** on the top surface of a substrate **930** (e.g., a silicon die or wafer) and a silicon dioxide layer **932B** on the bottom surface of the substrate **930**.

As shown in FIG. **9B**, at step **902** the process flow may continue to fabricating (e.g., by deposition, such as by sputtering) a silicon nitride layer **936** (e.g., Si₃N₄) on the top surface of the silicon dioxide layer **932A**.

As shown in FIG. **9C**, at step **904** the process flow may continue to fabricating (e.g., by deposition and patterning) a heater layer (e.g., TaN/NiFe/TaN) defining a heating structure **938** on the top surface of the silicon nitride layer **936**.

FIG. **9D** illustrates an example layout for the example thermopile-based flow sensing device **905** fabricated at step **904**. In some embodiments, the example thermopile-based flow sensing device **905** may be provided for sensing a flow of fluid **942** (e.g., a flow of a gas or liquid). In some embodiments, the example thermopile-based flow sensing device **905** may comprise a heating structure **938** having a centerline **940**.

As shown in FIG. **9E**, at step **906** the process flow may continue to fabricating (e.g., by deposition, such as by sputtering) a silicon nitride layer **944A** (e.g., Si₃N₄) on the top surface of the silicon nitride layer **936** and the heater layer defining the heating structure **938**.

As shown in FIG. **9F**, at step **908** the process flow may continue to fabricating (e.g., by deposition and patterning) a

first thermocouple material layer **946** (e.g., 60:40 NiFe, 80:20 NiFe) on the top surface of the silicon nitride layer **944A**.

FIG. **9G** illustrates an example layout for the example thermopile-based flow sensing device **909** fabricated at step **908**.

As shown in FIG. **9H**, at step **910** the process flow may continue to fabricating (e.g., by deposition, such as by sputtering, and patterning) a silicon nitride layer **944B** (e.g., Si₃N₄) on the top surface of the silicon nitride layer **944A** and the first thermocouple material layer **946** and opening contact vias in the silicon nitride layer **944B** to provide access to the top surface of the first thermocouple material layer **946**.

FIG. **9I** illustrates an example layout for the example thermopile-based flow sensing device **911** fabricated at step **910**.

As shown in FIG. **9J**, at step **908** the process flow may continue to fabricating (e.g., by deposition and patterning) a second thermocouple material layer **948** (e.g., Cr) on the top surface of the first thermocouple material layer **946** through contact windows opened in the silicon nitride layer **944B**.

FIG. **9K** illustrates an example layout for the example thermopile-based flow sensing device **913** fabricated at step **912**. In some embodiments, the example thermopile-based flow sensing device **913** may be provided for sensing a flow of fluid **942** (e.g., a flow of a gas or liquid). In some embodiments, the example thermopile-based flow sensing device **913** may comprise a heating structure **938** having a centerline **940**. In some embodiments, the example thermopile-based flow sensing device **913** may further comprise a thermopile **950**. In some embodiments, at least a portion of the thermopile **950** may be disposed over the heating structure **938**.

In some embodiments, the thermopile **950** may comprise a plurality of thermocouples having a plurality of thermocouple junctions. In some embodiments, the plurality of thermocouples may have a plurality of upstream thermocouple junctions **952** (e.g., nineteen upstream thermocouple junctions) disposed upstream of the centerline **940** of the heating structure **938**. In some embodiments, the plurality of thermocouples may have a plurality of downstream thermocouple junctions **954** (e.g., nineteen downstream thermocouple junctions) disposed downstream of the centerline **940** of the heating structure **938**. In some embodiments, the number of upstream thermocouple junctions **952** and the number of downstream thermocouple junctions **954** may be the same. In some embodiments, the number of upstream thermocouple junctions **952** and the number of downstream thermocouple junctions **954** may depend (e.g., may be a function of) the Seebeck coefficient of the first thermocouple material layer **946**, the Seebeck coefficient of the second thermocouple material layer **948**, and the desired output voltage.

In some embodiments, each of the plurality of upstream thermocouple junctions **952** and the plurality of downstream thermocouple junctions **954** may be aligned parallel to centerline **940** and occur along an upstream vertical line through about a minimum temperature difference location (e.g., minimum temperature difference location **222** shown in FIGS. **2A** and **2B**) and a downstream vertical line through about a maximum temperature difference location (e.g., maximum temperature difference location **224** shown in FIGS. **2A** and **2B**), respectively. For example, a maximum temperature difference may be defined by a minimum temperature difference located at a first location (e.g., minimum temperature difference location **222** FIGS. **2A** and **2B**)

upstream of the centerline **940** and a maximum temperature difference located at a second location (e.g., maximum temperature difference location **224** shown in FIGS. **2A** and **2B**) downstream of the centerline **940**; the plurality of upstream thermocouple junctions **952** may be disposed upstream of the centerline **940** at about a first plurality of points on a first line that extends through about the first location and is aligned substantially parallel to the centerline **940**; and the plurality of downstream thermocouple junctions **954** may be disposed downstream of the centerline **940** at about a second plurality of points on a second line that extends through about the second location and is aligned substantially parallel to the centerline **940**. In some embodiments, the plurality of upstream thermocouple junctions **952** and the plurality of downstream thermocouple junctions **954** may not be disposed over the heating structure **938**.

In some embodiments, the example thermopile-based flow sensing device **913** may further comprise a plurality of upstream sample temperature sensing thermocouple junctions **956** (e.g., two upstream sample temperature sensing thermocouple junctions) disposed upstream of the centerline **940** of the heating structure **938**. In some embodiments, the example thermopile-based flow sensing device **913** may further comprise a plurality of downstream sample temperature sensing thermocouple junctions **958** (e.g., two downstream sample temperature sensing thermocouple junctions) disposed downstream of the centerline **940** of the heating structure **938**. In some embodiments, the plurality of upstream sample temperature sensing thermocouple junctions **956** and the plurality of downstream sample temperature sensing thermocouple junctions **958** may not be disposed over the heating structure **938**.

In some embodiments, each of the plurality of upstream thermocouple junctions **952**, the plurality of downstream thermocouple junctions **954**, the plurality of upstream sample temperature sensing thermocouple junctions **956**, and the plurality of downstream sample temperature sensing thermocouple junctions **958** may comprise a respective interface between a first thermocouple material and a second thermocouple material as described in greater detail with reference to FIGS. **9J** and **11**.

As shown in FIG. **9L**, at step **914** the process flow may continue to fabricating (e.g., by deposition, such as by sputtering, and patterning) a silicon nitride layer **944C** (e.g., Si₃N₄) on the top surface of the silicon nitride layer **944B** and the second thermocouple material layer **948** and opening contact vias in the silicon nitride layer **944C** to provide access to the top surface of the second thermocouple material layer **948**.

FIG. **9M** illustrates an example layout for the example thermopile-based flow sensing device **915** fabricated at step **914**.

As shown in FIG. **9N**, at step **916** the process flow may continue to fabricating (e.g., by deposition and patterning) an electrical contact layer **960** (e.g., TiW/Al, TiW/2% Al—Cu) on the top surface of the second thermocouple material layer **948** through the contact vias opened in the silicon nitride layer **944C**.

FIG. **9O** illustrates an example layout for the example thermopile-based flow sensing device **917** fabricated at step **916**.

As shown in FIG. **9P**, at step **918** the process flow may continue to fabricating (e.g., by plasma enhanced chemical vapor deposition (PECVD)) a silicon nitride overcoat layer **962** (e.g., Si_xN_y—H) on the top surface of the silicon nitride layer **944C** and the electrical contact layer **960** and opening

contact vias in the silicon nitride overcoat layer **962** to provide access to the top surface of the electrical contact layer **960**.

FIG. **9Q** illustrates an example layout for the example thermopile-based flow sensing device **919** fabricated at step **918**.

As shown in FIG. **9R**, at step **920** the process flow may continue to fabricating a membrane structure by forming (e.g., by DRIE) a cavity **964** through the silicon dioxide layer **932B** and the substrate **930** until reaching the bottom surface of the silicon dioxide layer **932A**. At step **920** the process flow may include forming (e.g., by DRIE) one or more side cavities **966** through the silicon dioxide layer **932B** and a portion of the substrate **930** (e.g., through 70% of the thickness of the substrate **930**).

FIG. **9S** illustrates an example layout for the example thermopile-based flow sensing device **921** fabricated at step **920**. In some embodiments, the example thermopile-based flow sensing device **921** may comprise a substrate defining a membrane structure **968**. In some embodiments, a portion of the heating structure **938** may be disposed over the membrane structure **968**. In some embodiments, the thermopile **950**, the plurality of thermocouples, the plurality of upstream thermocouple junctions **952**, the plurality of downstream thermocouple junctions **954**, the plurality of upstream sample temperature sensing thermocouple junctions **956**, the plurality of downstream sample temperature sensing thermocouple junctions **958**, one or more portions thereof, or a combination thereof may be disposed over the membrane structure **968**. In some embodiments, the membrane structure **968** may provide thermal isolation from the substrate **930**, which may have a high thermal conductivity. In some embodiments, the shape of the membrane structure **968** may be rectangular, square, circular, oval, or any other suitable shape or combination thereof.

In other embodiments (not shown in FIG. **9** for the sake of brevity), the example thermopile-based flow sensing device **921** may comprise a substrate defining a microbridge structure. In some embodiments, a portion of the heating structure **938** may be disposed over the microbridge structure. In some embodiments, the thermopile **950**, the plurality of thermocouples, the plurality of upstream thermocouple junctions **952**, the plurality of downstream thermocouple junctions **954**, the plurality of upstream sample temperature sensing thermocouple junctions **956**, the plurality of downstream sample temperature sensing thermocouple junctions **958**, one or more portions thereof, or a combination thereof may be disposed over the microbridge structure.

FIG. **9T** illustrates a legend for the various example layers described with reference to FIGS. **9A**, **9B**, **9C**, **9E**, **9F**, **9H**, **9J**, **9L**, **9N**, **9P**, and **9R**.

FIG. **10** illustrates an example layout for an example thermopile-based flow sensing device **1000** in accordance with some example embodiments described herein. In some embodiments, the example thermopile-based flow sensing device **1000** may be provided for sensing a flow of fluid **1001** (e.g., a flow of a gas or liquid). In some embodiments, the example thermopile-based flow sensing device **1000** may comprise a heating structure **1002** having a centerline **1004**. In some embodiments, the example thermopile-based flow sensing device **1000** may further comprise a thermopile **1006**. In some embodiments, at least a portion of the thermopile **1006** may be disposed over the heating structure **1002**.

In some embodiments, the thermopile **1006** may comprise a plurality of thermocouples having a plurality of thermocouple junctions. In some embodiments, the plurality of

thermocouples may have a plurality of upstream thermocouple junctions **1008** (e.g., nineteen upstream thermocouple junctions) disposed upstream of the centerline **1004** of the heating structure **1002**. In some embodiments, the plurality of thermocouples may have a plurality of downstream thermocouple junctions **1010** (e.g., nineteen downstream thermocouple junctions) disposed downstream of the centerline **1004** of the heating structure **1002**. In some embodiments, the plurality of upstream thermocouple junctions **1008** and the plurality of downstream thermocouple junctions **1010** may not be disposed over the heating structure **1002**. In some embodiments, the number of upstream thermocouple junctions **1008** and the number of downstream thermocouple junctions **1010** may be the same. In some embodiments, the number of upstream thermocouple junctions **1008** and the number of downstream thermocouple junctions **1010** may depend (e.g., may be a function of) the Seebeck coefficients of the thermocouple materials in the thermocouples and the desired output voltage.

In some embodiments, the example thermopile-based flow sensing device **1000** may further comprise a plurality of upstream sample temperature sensing thermocouple junctions **1012** (e.g., two upstream sample temperature sensing thermocouple junctions) disposed upstream of the centerline **1004** of the heating structure **1002**. In some embodiments, the example thermopile-based flow sensing device **1000** may further comprise a plurality of downstream sample temperature sensing thermocouple junctions **1014** (e.g., two downstream sample temperature sensing thermocouple junctions) disposed downstream of the centerline **1004** of the heating structure **1002**. In some embodiments, the plurality of upstream sample temperature sensing thermocouple junctions **1012** and the plurality of downstream sample temperature sensing thermocouple junctions **1014** may not be disposed over the heating structure **1002**.

In some embodiments, each of the plurality of upstream thermocouple junctions **1008**, the plurality of downstream thermocouple junctions **1010**, the plurality of upstream sample temperature sensing thermocouple junctions **1012**, and the plurality of downstream sample temperature sensing thermocouple junctions **1014** may comprise a respective interface between a first thermocouple material and a second thermocouple material as described in greater detail with reference to FIG. **11**.

In some embodiments, as shown in FIG. **10**, the example thermopile-based flow sensing device **1000** may comprise a substrate defining a membrane structure **1016**. In some embodiments, a portion of the heating structure **1002** may be disposed over the membrane structure **1016**. In some embodiments, the thermopile **1006**, the plurality of thermocouples, the plurality of upstream thermocouple junctions **1008**, the plurality of downstream thermocouple junctions **1010**, the plurality of upstream sample temperature sensing thermocouple junctions **1012**, the plurality of downstream sample temperature sensing thermocouple junctions **1014**, one or more portions thereof, or a combination thereof may be disposed over the membrane structure **1016**. In some embodiments, the membrane structure **1016** may provide thermal isolation from the bulk (e.g., silicon) die, which may have a high thermal conductivity. In some embodiments, the shape of the membrane structure **1016** may be rectangular, square, circular, oval, or any other suitable shape or combination thereof.

In other embodiments (not shown in FIG. **10** for the sake of brevity), the example thermopile-based flow sensing device **1000** may comprise a substrate defining a microbridge structure. In some embodiments, a portion of the

heating structure **1002** may be disposed over the micro-bridge structure. In some embodiments, the thermopile **1006**, the plurality of thermocouples, the plurality of upstream thermocouple junctions **1008**, the plurality of downstream thermocouple junctions **1010**, the plurality of upstream sample temperature sensing thermocouple junctions **1012**, the plurality of downstream sample temperature sensing thermocouple junctions **1014**, one or more portions thereof, or a combination thereof may be disposed over the microbridge structure.

FIG. **11** illustrates an example table **1100** of thermocouple materials for use in an example thermopile-based flow sensing device in accordance with some example embodiments described herein. For example, the thermocouple materials shown in example table **1100** may be used to provide a thermocouple junction comprising an interface between a first thermocouple material and a second thermocouple material. In some embodiments, the number of thermocouple junctions in the thermopile of an example thermopile-based flow sensing device disclosed herein may depend (e.g., may be a function of) the Seebeck coefficients of the thermocouple materials in the thermocouples of the thermopile and the desired output voltage. The term “dS” refers to the difference between the Seebeck coefficients of the thermocouple materials in a thermocouple.

In some embodiments, the first thermocouple material may comprise polysilicon, and the second thermocouple material may comprise aluminum. In some embodiments, the first thermocouple material and the second thermocouple material may comprise differently doped polysilicon (e.g., n-type and p-type polysilicon). For example, the first thermocouple material may comprise n-type polysilicon (nPoly Si), and the second thermocouple material may comprise p-type polysilicon (pPoly Si). In another example, the first thermocouple material may comprise p-type polysilicon (pPoly Si), and the second thermocouple material may comprise n-type polysilicon (nPoly Si).

In some embodiments, the first thermocouple material may comprise a nickel-iron alloy (e.g., 60:40 NiFe, 80:20 NiFe), and the second thermocouple material may comprise chromium (Cr), where dS is about 65 uV/C for 60:40 NiFe and Cr or about 53 uV/C for 80:20 NiFe and Cr. In some embodiments, the first thermocouple material may comprise a nickel-iron alloy (e.g., 60:40 NiFe, 80:20 NiFe), and the second thermocouple material may comprise chromium disilicide (CrSi₂), where dS is about 105 uV/C for 60:40 NiFe and CrSi₂ or about 93 uV/C for 80:20 NiFe and CrSi₂. In some embodiments, the first thermocouple material may comprise a nickel-iron alloy (e.g., 60:40 NiFe, 80:20 NiFe), and the second thermocouple material may comprise rhenium disilicide (ReSi₂).

In some embodiments, the first thermocouple material may comprise chromium nitride (e.g., CrN), and the second thermocouple material may comprise copper (Cu), where dS is about 146 uV/C for CrN and Cu. In some embodiments, the first thermocouple material may comprise chromium nitride (e.g., CrN), and the second thermocouple material may comprise aluminum (Al), where dS is about 138 uV/C for CrN and Al. In some embodiments, the first thermocouple material may comprise a chromium nitride (e.g., CrN), and the second thermocouple material may comprise p-type polysilicon (pPoly Si), where dS is about 270 uV/C for CrN and pPoly Si.

In some embodiments, the first thermocouple material may comprise copper (Cu), and the second thermocouple material may comprise a copper-nickel alloy (e.g., Constantan).

In some embodiments, the thermopile-based flow sensing device disclosed herein may comprise any combination of components, structures, and features discussed with reference to example thermopile-based flow sensing devices **100**, **200**, **300**, **400**, **500**, **600**, **700**, **800**, and **1000**, and any of the example thermopile-based flow sensing devices described with reference to FIG. **9** (e.g., example thermopile-based flow sensing devices **913**, **915**, **917**, **919**, **921**), including the addition or omission of components, structures, and features.

Having described specific components of example devices involved in the present disclosure, example procedures for providing a thermopile-based flow sensing device are described below in connection with FIGS. **12** and **13**.

FIG. **12** illustrates an example flowchart **1200** that contains example operations for manufacturing or otherwise providing an apparatus (e.g., apparatus **100**, **200**, **300**, **400**, **500**, **600**, **913**, **915**, **917**, **919**, **921**, **1000**) for sensing a flow of fluid according to some example embodiments described herein.

As shown by operation **1202**, the example flowchart **1200** may begin by providing a heating structure (e.g., heating structure **102**, **202**, **302**, **402**, **502**, **602**, **938**, **1002**) having a centerline (e.g., centerline **104**, **204**, **304**, **404**, **504**, **604**, **940**, **1004**).

As shown by operation **1204**, the example flowchart **1200** may proceed to disposing at least a portion of a thermopile (e.g., thermopile **106**, **206**, **306**, **406**, **506**, **606**, **950**, **1006**) over the heating structure. The thermopile may comprise a first thermocouple having a first thermocouple junction (e.g., one of the one or more upstream thermocouple junctions **108**, **308**, **408**, **508**, **608**, **952**, **1008**) disposed upstream of the centerline of the heating structure. The thermopile may further comprise a second thermocouple having a second thermocouple junction (e.g., one of the one or more downstream thermocouple junctions **110**, **310**, **410**, **510**, **610**, **954**, **1010**) disposed downstream of the centerline of the heating structure. In some embodiments, the number of upstream thermocouple junctions and the number of downstream thermocouple junctions in the thermopile may depend (e.g., may be a function of) the Seebeck coefficients of the thermocouple materials in the thermocouples and the desired output voltage.

In some embodiments, operations **1202** and **1204** may not necessarily occur in the order depicted in FIG. **12**. In some embodiments, one or more of the operations depicted in FIG. **12** may occur substantially simultaneously. In some embodiments, one or more additional operations may be involved before, after, or between any of the operations shown in FIG. **12**.

FIG. **13** illustrates an example flowchart **1300** that contains example operations for manufacturing or otherwise providing an apparatus (e.g., apparatus **700**, **800**) for sensing a flow of fluid according to some example embodiments described herein.

As shown by operation **1302**, the example flowchart **1300** may begin by providing a heating structure (e.g., heating structure **702**, **802**) having a centerline (e.g., centerline **704**, **804**).

As shown by operation **1304**, the example flowchart **1300** may proceed to disposing a first thermopile (e.g., thermopile **706**, **806**) upstream of the centerline of the heating structure. The first thermopile may comprise a first plurality of thermocouples disposed upstream of the centerline of the heating structure. In some embodiments, the first plurality of thermocouples may comprise a first subset of the first plurality of thermocouples (e.g., upstream parallel thermo-

couples **808, 820**) aligned substantially parallel to the centerline of the heating structure. In some embodiments, the first plurality of thermocouples may further comprise a second subset of the first plurality of thermocouples (e.g., upstream perpendicular thermocouples **814**) aligned substantially perpendicular to the centerline of the heating structure. In some instances, the first thermopile may be disposed above the heating structure, such as in a layer above the heating structure but not over the heating structure.

As shown by operation **1306**, the example flowchart **1300** may proceed to disposing a second thermopile (e.g., thermopile **710, 826**) downstream of the centerline of the heating structure. The second thermopile may comprise a second plurality of thermocouples disposed downstream of the centerline of the heating structure. In some embodiments, the second plurality of thermocouples may comprise a third subset of the second plurality of thermocouples (e.g., downstream parallel thermocouples **828, 840**) aligned substantially parallel to the centerline of the heating structure. In some embodiments, the second plurality of thermocouples may further comprise a fourth subset of the second plurality of thermocouples (e.g., downstream perpendicular thermocouples **834**) aligned substantially perpendicular to the centerline of the heating structure. In some instances, the second thermopile may be disposed above the heating structure, such as in a layer above the heating structure but not over the heating structure.

In some embodiments, operations **1302, 1304, and 1306** may not necessarily occur in the order depicted in FIG. **13**. In some embodiments, one or more of the operations depicted in FIG. **13** may occur substantially simultaneously. In some embodiments, one or more additional operations may be involved before, after, or between any of the operations shown in FIG. **13**.

FIGS. **12** and **13** thus illustrate example flowcharts describing operations performed in accordance with example embodiments of the present disclosure. It will be understood that each operation of the flowcharts, and combinations of operations in the flowcharts, may be implemented by various means, such as devices comprising hardware, firmware, one or more processors, and/or circuitry associated with execution of software comprising one or more computer program instructions. In some embodiments, one or more of the procedures described above may be performed by execution of program code instructions. For example, one or more of the procedures described above may be performed by material handling equipment (e.g., a robotic arm, servo motor, motion controllers, and the like) and computer program instructions residing on a non-transitory computer-readable storage memory. In this regard, the program code instructions that, when executed, cause performance of the procedures described above may be stored by a non-transitory computer-readable storage medium (e.g., memory) of a computing apparatus and executed by a processor of the computing apparatus. In this regard, the computer program instructions which embody the procedures described above may be stored by a memory of an apparatus employing an embodiment of the present disclosure and executed by a processor of the apparatus. As will be appreciated, any such computer program instructions may be loaded onto a computer or other programmable apparatus (e.g., hardware) to produce a machine, such that the resulting computer or other programmable apparatus provides for implementation of the functions specified in the flowcharts **1200** and **1300**. When executed, the instructions stored in the computer-readable storage memory produce an

article of manufacture configured to implement the various functions specified in the flowcharts **1200** and **1300**. The program code instructions may also be loaded onto a computer or other programmable apparatus to cause a series of operations to be performed on the computer or other programmable apparatus to produce a computer-implemented process such that the instructions executed on the computer or other programmable apparatus provide operations for implementing the functions specified in the operations of flowcharts **1200** and **1300**. Moreover, execution of a computer or other processing circuitry to perform various functions converts the computer or other processing circuitry into a particular machine configured to perform an example embodiment of the present disclosure.

The flowchart operations described with reference to FIGS. **12** and **13** support combinations of means for performing the specified functions and combinations of operations for performing the specified functions. It will be understood that one or more operations of the flowcharts, and combinations of operations in the flowcharts, may be implemented by special purpose hardware-based computer systems which perform the specified functions, or combinations of special purpose hardware and computer instructions.

In some example embodiments, certain ones of the operations herein may be modified or further amplified as described below. Moreover, in some embodiments additional optional operations may also be included. It should be appreciated that each of the modifications, optional additions or amplifications described herein may be included with the operations herein either alone or in combination with any others among the features described herein.

The foregoing method descriptions and the process flow diagrams are provided merely as illustrative examples and are not intended to require or imply that the steps of the various embodiments must be performed in the order presented. As will be appreciated by one of skill in the art the order of steps in the foregoing embodiments may be performed in any order. Words such as “thereafter,” “then,” “next,” and similar words are not intended to limit the order of the steps; these words are simply used to guide the reader through the description of the methods. Further, any reference to claim elements in the singular, for example, using the articles “a,” “an” or “the,” is not to be construed as limiting the element to the singular and may, in some instances, be construed in the plural.

As described above and as will be appreciated based on this disclosure, embodiments of the present disclosure may be configured as systems, apparatuses, methods, mobile devices, backend network devices, computer program products, other suitable devices, and combinations thereof. Accordingly, embodiments may comprise various means including entirely of hardware or any combination of software with hardware. Furthermore, embodiments may take the form of a computer program product on at least one non-transitory computer-readable storage medium having computer-readable program instructions (e.g., computer software) embodied in the storage medium. Any suitable computer-readable storage medium may be utilized including non-transitory hard disks, CD-ROMs, flash memory, optical storage devices, or magnetic storage devices. As will be appreciated, any computer program instructions and/or other type of code described herein may be loaded onto a computer, processor or other programmable apparatus's circuitry to produce a machine, such that the computer, processor, or other programmable circuitry that executes the code on the machine creates the means for implementing

various functions, including those described herein. In some embodiments, features of the present disclosure may comprise, or be communicatively coupled to, an application specific integrated circuit (ASIC) configured to convert the differential output voltage from the thermopile or thermopiles (e.g., either in a single chip or two-chip configuration).

While various embodiments in accordance with the principles disclosed herein have been shown and described above, modifications thereof may be made by one skilled in the art without departing from the teachings of the disclosure. The embodiments described herein are representative only and are not intended to be limiting. Many variations, combinations, and modifications are possible and are within the scope of the disclosure. Alternative embodiments that result from combining, integrating, and/or omitting features of the embodiment(s) are also within the scope of the disclosure. Accordingly, the scope of protection is not limited by the description set out above, but is defined by the claims which follow, that scope including all equivalents of the subject matter of the claims. Each and every claim is incorporated as further disclosure into the specification and the claims are embodiment(s) of the present disclosure. Furthermore, any advantages and features described above may relate to specific embodiments, but shall not limit the application of such issued claims to processes and structures accomplishing any or all of the above advantages or having any or all of the above features.

In addition, the section headings used herein are provided for consistency with the suggestions under 37 C.F.R. § 1.77 or to otherwise provide organizational cues. These headings shall not limit or characterize the disclosure set out in any claims that may issue from this disclosure. For instance, a description of a technology in the "Background" is not to be construed as an admission that certain technology is prior art to any disclosure in this disclosure. Neither is the "Summary" to be considered as a limiting characterization of the disclosure set forth in issued claims. Furthermore, any reference in this disclosure to "disclosure" or "embodiment" in the singular should not be used to argue that there is only a single point of novelty in this disclosure. Multiple embodiments of the present disclosure may be set forth according to the limitations of the multiple claims issuing from this disclosure, and such claims accordingly define the disclosure, and their equivalents, that are protected thereby. In all instances, the scope of the claims shall be considered on their own merits in light of this disclosure, but should not be constrained by the headings set forth herein.

Also, systems, subsystems, apparatuses, techniques, and methods described and illustrated in the various embodiments as discrete or separate may be combined or integrated with other systems, modules, techniques, or methods without departing from the scope of the present disclosure. Other devices or components shown or discussed as coupled to, or in communication with, each other may be indirectly coupled through some intermediate device or component, whether electrically, mechanically, or otherwise. Other examples of changes, substitutions, and alterations are ascertainable by one skilled in the art and could be made without departing from the scope disclosed herein.

Many modifications and other embodiments of the disclosure set forth herein will come to mind to one skilled in the art to which these embodiments pertain having the benefit of teachings presented in the foregoing descriptions and the associated figures. Although the figures only show certain components of the apparatuses and systems described herein, various other components may be used in conjunction with the components and structures disclosed

herein. Therefore, it is to be understood that the disclosure is not to be limited to the specific embodiments disclosed and that modifications and other embodiments are intended to be included within the scope of the appended claims. For example, the various elements or components may be combined, rearranged, or integrated in another system or certain features may be omitted or not implemented. Moreover, the steps in any method described above may not necessarily occur in the order depicted in the accompanying drawings, and in some cases one or more of the steps depicted may occur substantially simultaneously, or additional steps may be involved. Although specific terms are employed herein, they are used in a generic and descriptive sense only and not for purposes of limitation.

The invention claimed is:

1. An apparatus for sensing a flow of fluid, the apparatus comprising:

a flow sensing device comprising:

a heating structure having a centerline; and

a thermopile, wherein at least a portion of the thermopile is disposed over the heating structure, and wherein the thermopile comprises

a first thermocouple having a first thermocouple junction disposed upstream of the centerline, and

a second thermocouple having a second thermocouple junction disposed downstream of the centerline.

2. The apparatus of claim 1, further comprising a substrate defining a microbridge structure, wherein a portion of the heating structure is disposed over the microbridge structure.

3. The apparatus of claim 1, further comprising a substrate defining a membrane structure, wherein a portion of the heating structure is disposed over the membrane structure.

4. The apparatus of claim 1, wherein the first thermocouple junction is disposed over the heating structure, and wherein the second thermocouple junction is disposed over the heating structure.

5. The apparatus of claim 1, wherein the first thermocouple junction is not disposed over the heating structure, and wherein the second thermocouple junction is not disposed over the heating structure.

6. The apparatus of claim 1, wherein a maximum temperature difference is defined by a minimum temperature difference located at a first location upstream of the centerline and a maximum temperature difference located at a second location downstream of the centerline, wherein the first thermocouple junction is disposed at about the first location, and wherein the second thermocouple junction is disposed at about the second location.

7. The apparatus of claim 1, wherein the thermopile comprises:

a first plurality of thermocouples having a first plurality of thermocouple junctions disposed upstream of the centerline; and

a second plurality of thermocouples having a second plurality of thermocouple junctions disposed downstream of the centerline.

8. The apparatus of claim 7, wherein the first plurality of thermocouple junctions and the second plurality of thermocouple junctions are disposed at about a plurality of locations on a maximum temperature difference isoline.

9. The apparatus of claim 1, wherein the first thermocouple junction comprises an interface between a first thermocouple material and a second thermocouple material, wherein the first thermocouple material comprises polysilicon, and wherein the second thermocouple material comprises aluminum.

31

10. The apparatus of claim 1, wherein the first thermocouple junction comprises an interface between a first thermocouple material and a second thermocouple material, wherein the first thermocouple material comprises n-type polysilicon, and wherein the second thermocouple material comprises p-type polysilicon.

11. The apparatus of claim 1, wherein the first thermocouple junction comprises an interface between a first thermocouple material and a second thermocouple material, wherein the first thermocouple material comprises p-type polysilicon, and wherein the second thermocouple material comprises n-type polysilicon.

12. The apparatus of claim 1, wherein the first thermocouple junction comprises an interface between a first thermocouple material and a second thermocouple material, wherein the first thermocouple material comprises a nickel-iron alloy, and wherein the second thermocouple material comprises chromium.

13. The apparatus of claim 1, wherein the first thermocouple junction comprises an interface between a first thermocouple material and a second thermocouple material, wherein the first thermocouple material comprises a nickel-iron alloy, and wherein the second thermocouple material comprises chromium disilicide.

14. The apparatus of claim 1, wherein the first thermocouple junction comprises an interface between a first thermocouple material and a second thermocouple material, wherein the first thermocouple material comprises a nickel-iron alloy, and wherein the second thermocouple material comprises rhenium disilicide.

15. The apparatus of claim 1, wherein the first thermocouple junction comprises an interface between a first thermocouple material and a second thermocouple material, wherein the first thermocouple material comprises chromium nitride, and wherein the second thermocouple material comprises copper.

16. The apparatus of claim 1, wherein the first thermocouple junction comprises an interface between a first thermocouple material and a second thermocouple material, wherein the first thermocouple material comprises chromium nitride, and wherein the second thermocouple material comprises aluminum.

17. The apparatus of claim 1, wherein the first thermocouple junction comprises an interface between a first thermocouple material and a second thermocouple material,

32

wherein the first thermocouple material comprises chromium nitride, and wherein the second thermocouple material comprises p-type polysilicon.

18. The apparatus of claim 1, wherein the first thermocouple junction comprises an interface between a first thermocouple material and a second thermocouple material, wherein the first thermocouple material comprises copper, and wherein the second thermocouple material comprises a copper-nickel alloy.

19. A method for manufacturing an apparatus for sensing a flow of fluid, the method comprising:

providing a heating structure having a centerline;
disposing at least a portion of a thermopile over the heating structure, wherein the thermopile comprises a first thermocouple having a first thermocouple junction disposed upstream of the centerline, and a second thermocouple having a second thermocouple junction disposed downstream of the centerline.

20. An apparatus for sensing a flow of fluid, the apparatus comprising:

flow sensing device comprising:
a heating structure having a centerline;
a first thermopile comprising a first plurality of thermocouples disposed upstream of the centerline, wherein the first plurality of thermocouples comprises a first subset of the first plurality of thermocouples aligned substantially parallel to the centerline, and wherein the first plurality of thermocouples comprises a second subset of the first plurality of thermocouples aligned substantially perpendicular to the centerline; and
a second thermopile comprising a second plurality of thermocouples disposed downstream of the centerline, wherein the second plurality of thermocouples comprises a third subset of the second plurality of thermocouples aligned substantially parallel to the centerline, and wherein the second plurality of thermocouples comprises a fourth subset of the second plurality of thermocouples aligned substantially perpendicular to the centerline.

* * * * *