

(12) **United States Patent**
Kendall et al.

(10) **Patent No.:** **US 10,766,212 B2**
(45) **Date of Patent:** **Sep. 8, 2020**

(54) **METHOD AND APPARATUS FOR FORMING RADIUS FILLER KITS**

(71) Applicant: **The Boeing Company**, Chicago, IL (US)

(72) Inventors: **James R. Kendall**, Mount Pleasant, SC (US); **Paul D. Shaw**, Charleston, SC (US); **Raviendra Sidath Suriyaarachchi**, Daniel Island, SC (US); **Sadie Lee Fieni**, Charleston, SC (US)

(73) Assignee: **The Boeing Company**, Chicago, IL (US)

(*) Notice: Subject to any disclaimer, the term of this patent is extended or adjusted under 35 U.S.C. 154(b) by 238 days.

(21) Appl. No.: **15/840,793**

(22) Filed: **Dec. 13, 2017**

(65) **Prior Publication Data**

US 2019/0176414 A1 Jun. 13, 2019

(51) **Int. Cl.**
B29C 70/74 (2006.01)
B29C 70/34 (2006.01)
B29L 31/30 (2006.01)

(52) **U.S. Cl.**
CPC **B29C 70/745** (2013.01); **B29C 70/342** (2013.01); **B29L 2031/3082** (2013.01)

(58) **Field of Classification Search**
CPC ... B29C 70/745; B29C 70/342; B29C 70/475; B29L 2031/3082
See application file for complete search history.

(56) **References Cited**

U.S. PATENT DOCUMENTS

8,333,864	B2	12/2012	Brennan et al.	
9,637,354	B2 *	5/2017	Forston	B66C 1/28
2012/0121866	A1	5/2012	Hawkins et al.	
2016/0075092	A1 *	3/2016	Wilcoxson	B64C 1/064
				156/222
2016/0107432	A1 *	4/2016	Krajca	B29D 99/0014
				156/250
2019/0009477	A1 *	1/2019	Gordon	B29D 99/0003

* cited by examiner

Primary Examiner — Vishal I Patel

(74) Attorney, Agent, or Firm — Yee & Associates, P.C.

(57) **ABSTRACT**

A plurality of segments of radius filler is positioned onto a radius filler forming tool. The plurality of segments of radius filler is applied to a stringer in a single placement step.

37 Claims, 15 Drawing Sheets

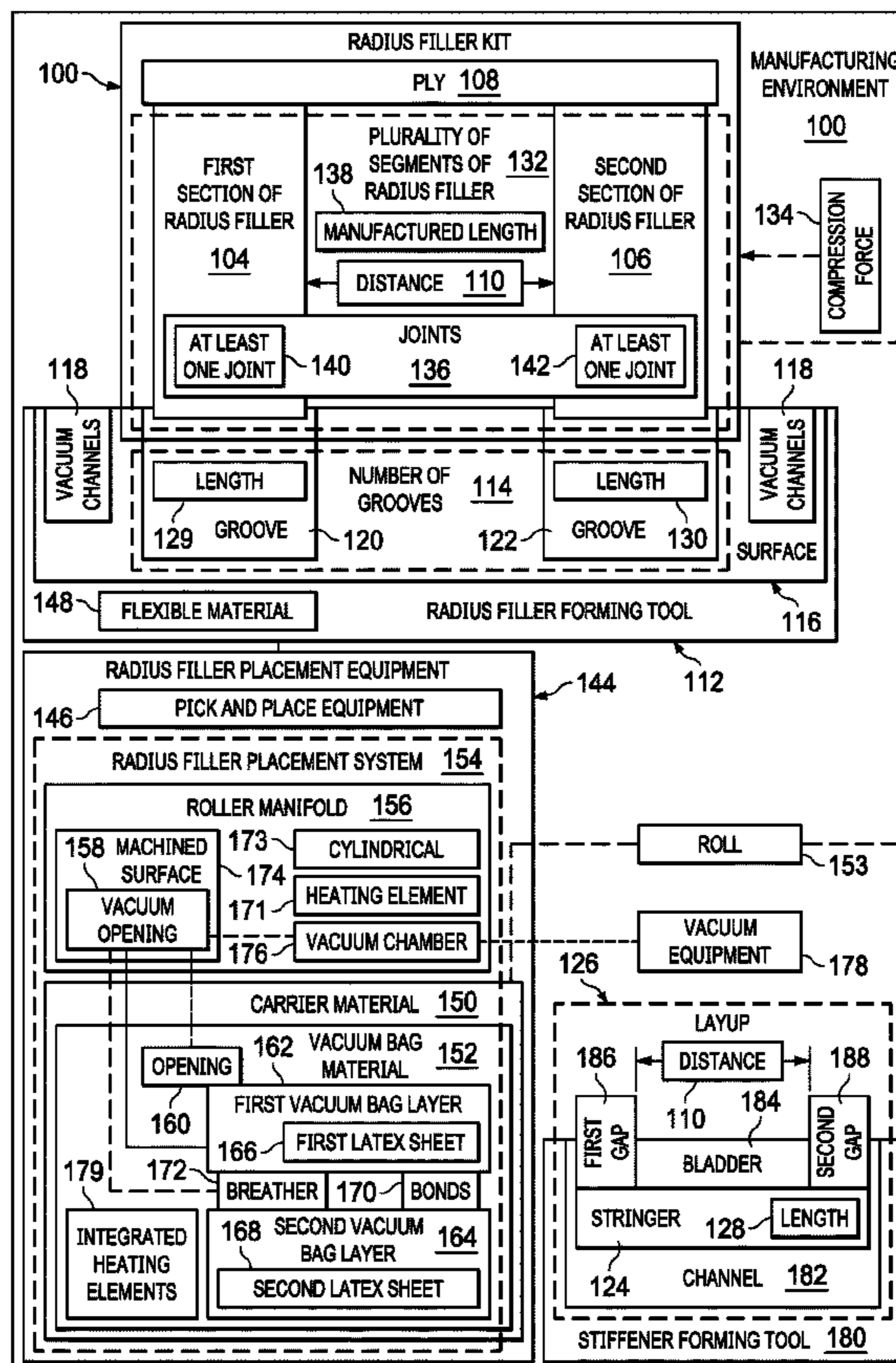
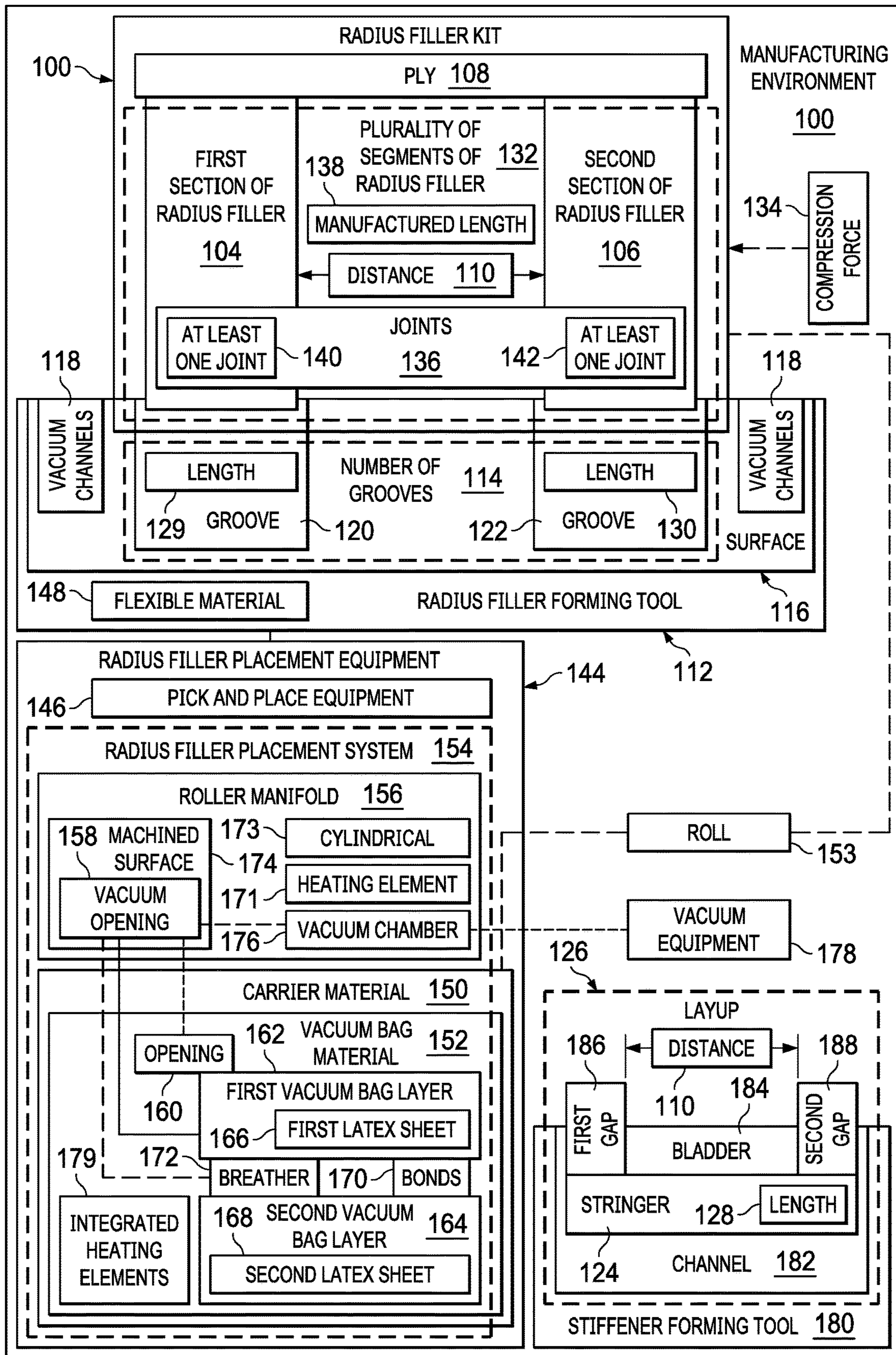

FIG. 1



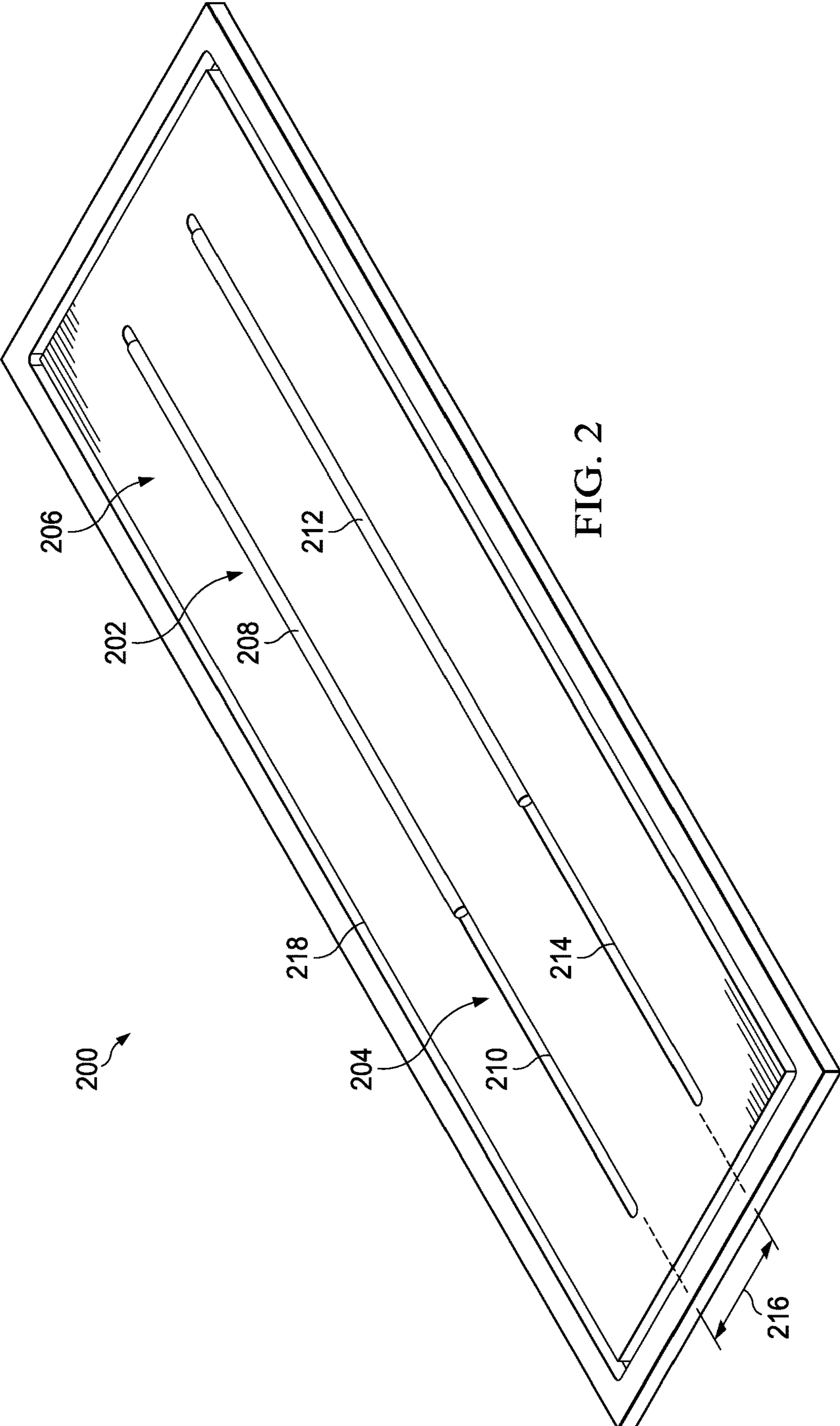

FIG. 2

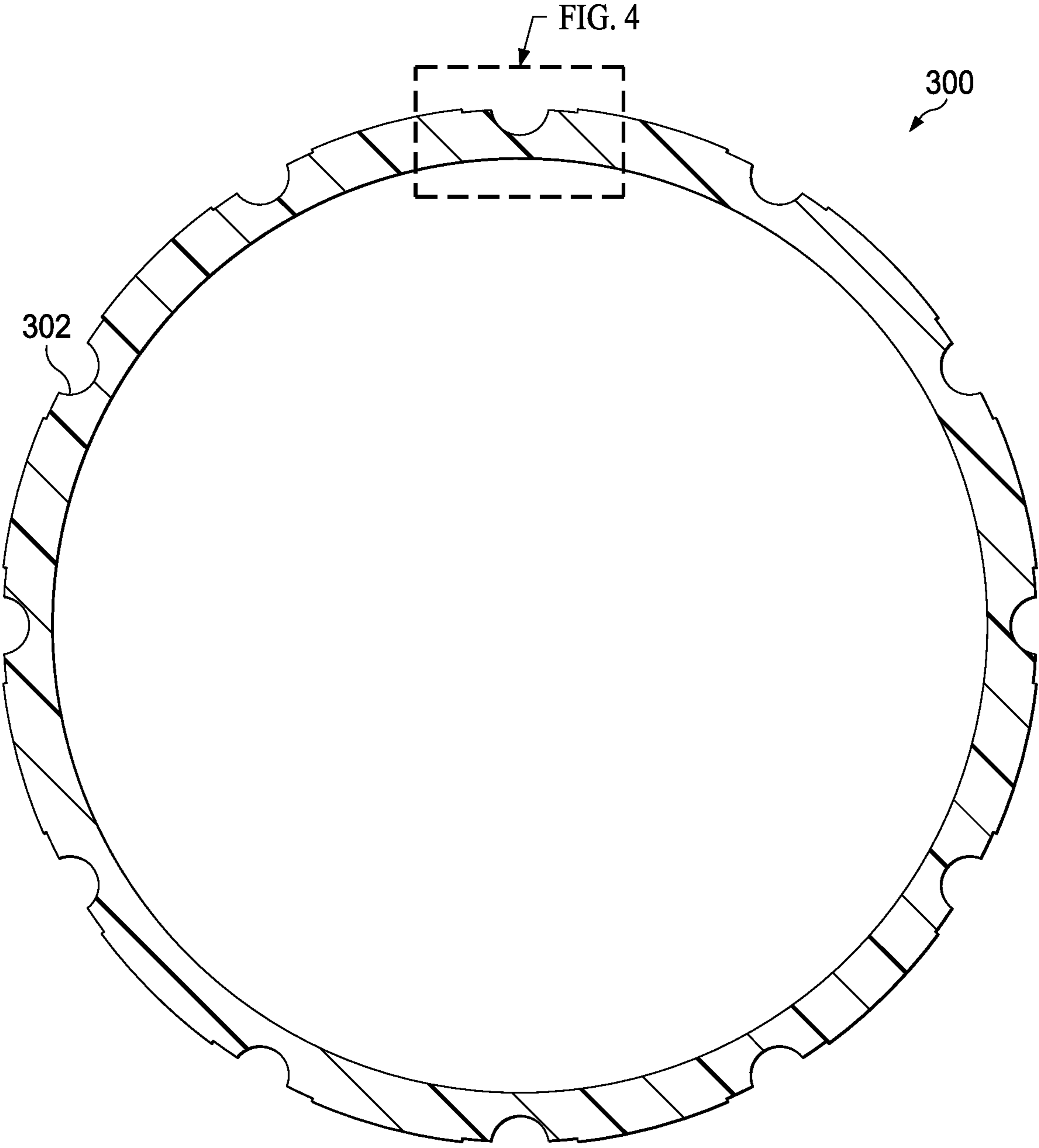

FIG. 3

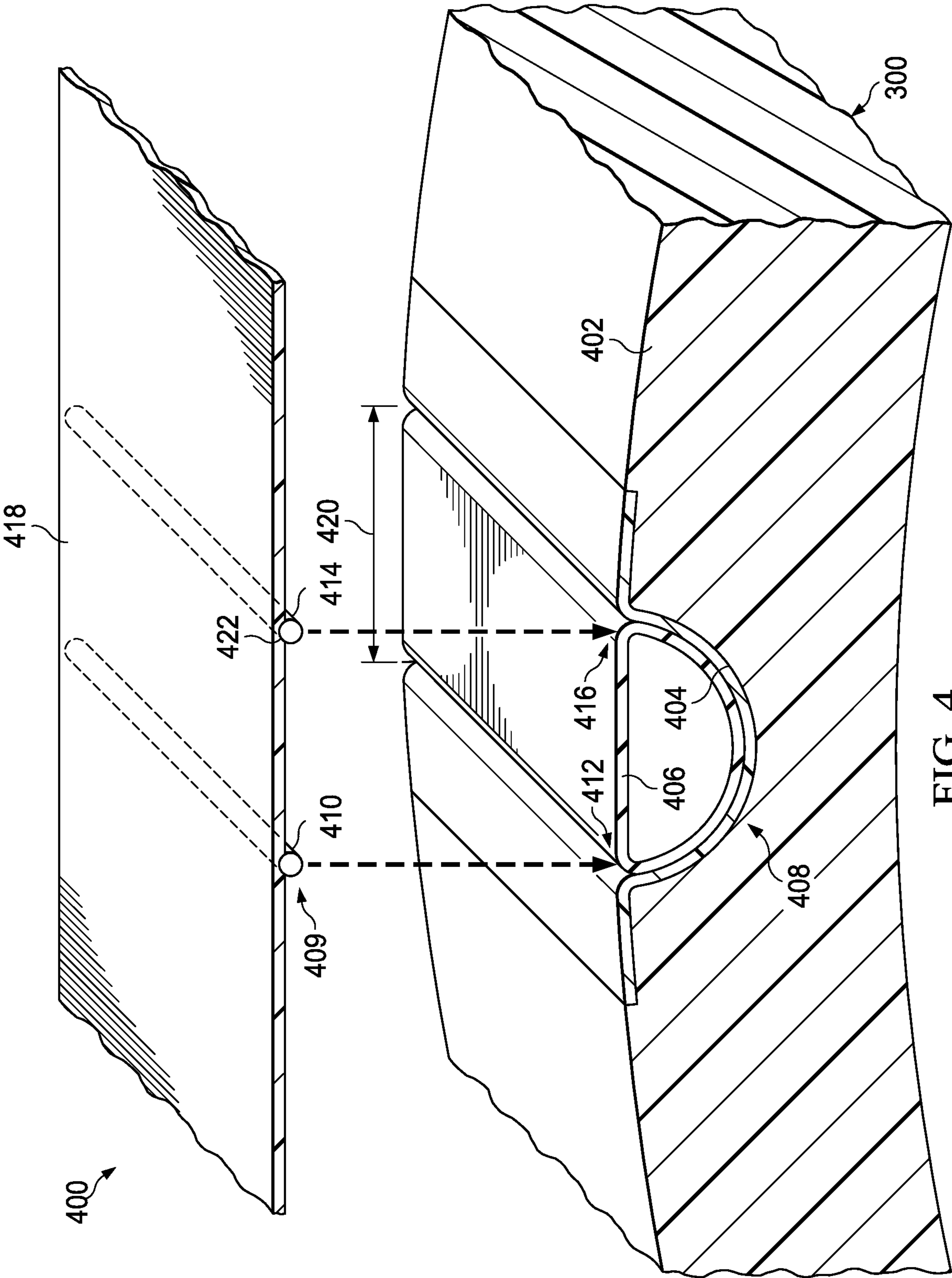

FIG. 4

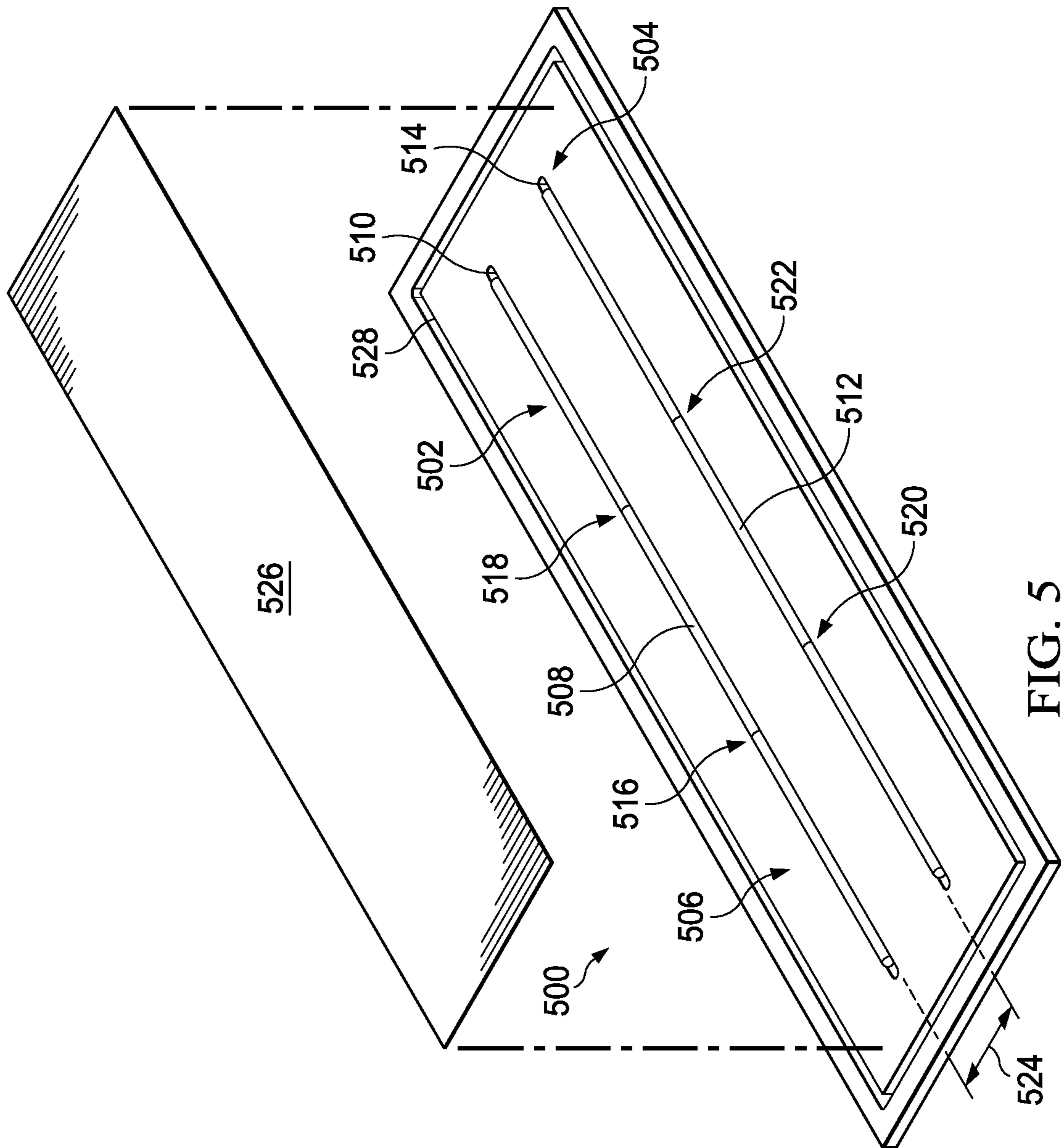

FIG. 5

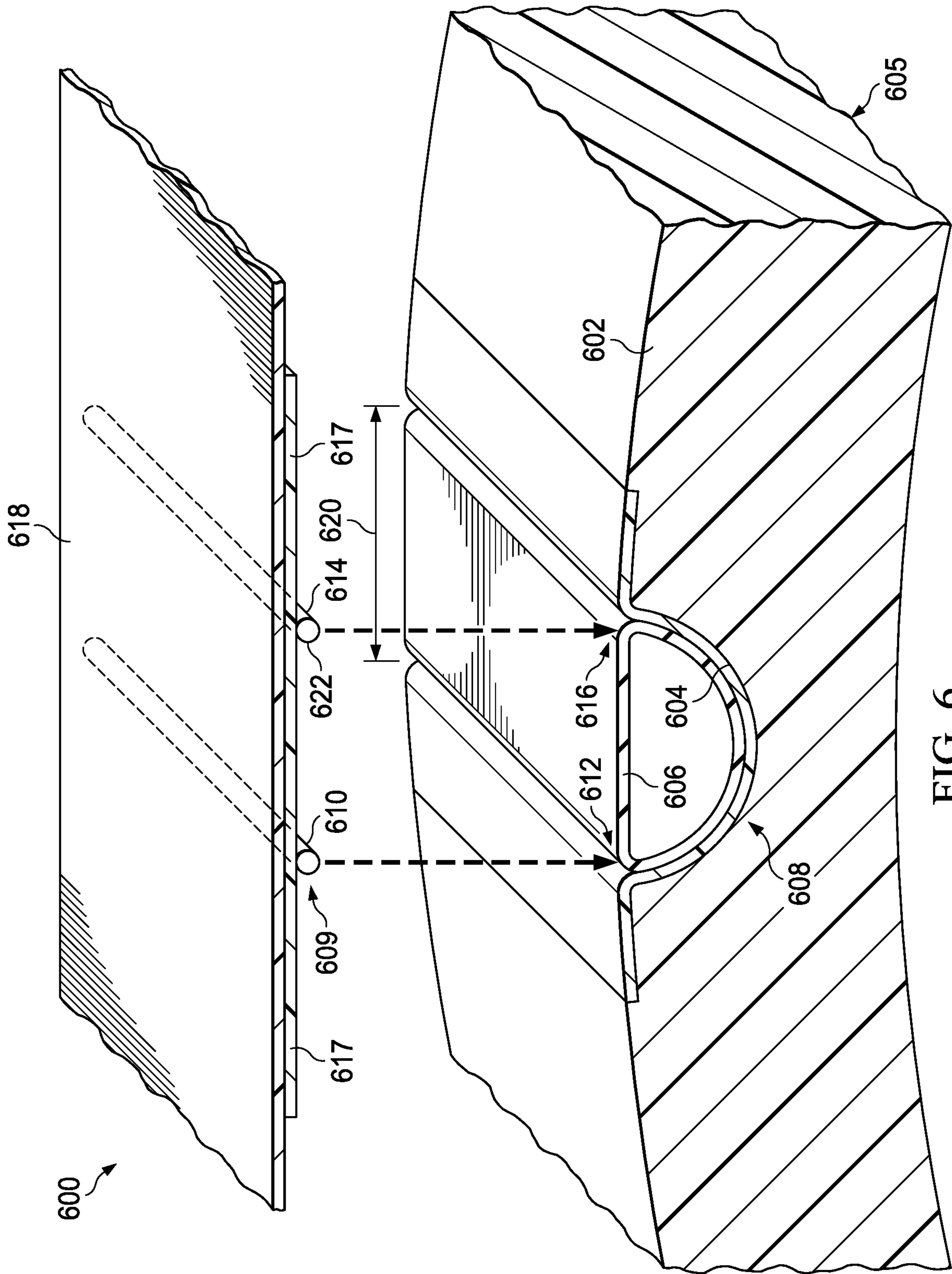

FIG. 6

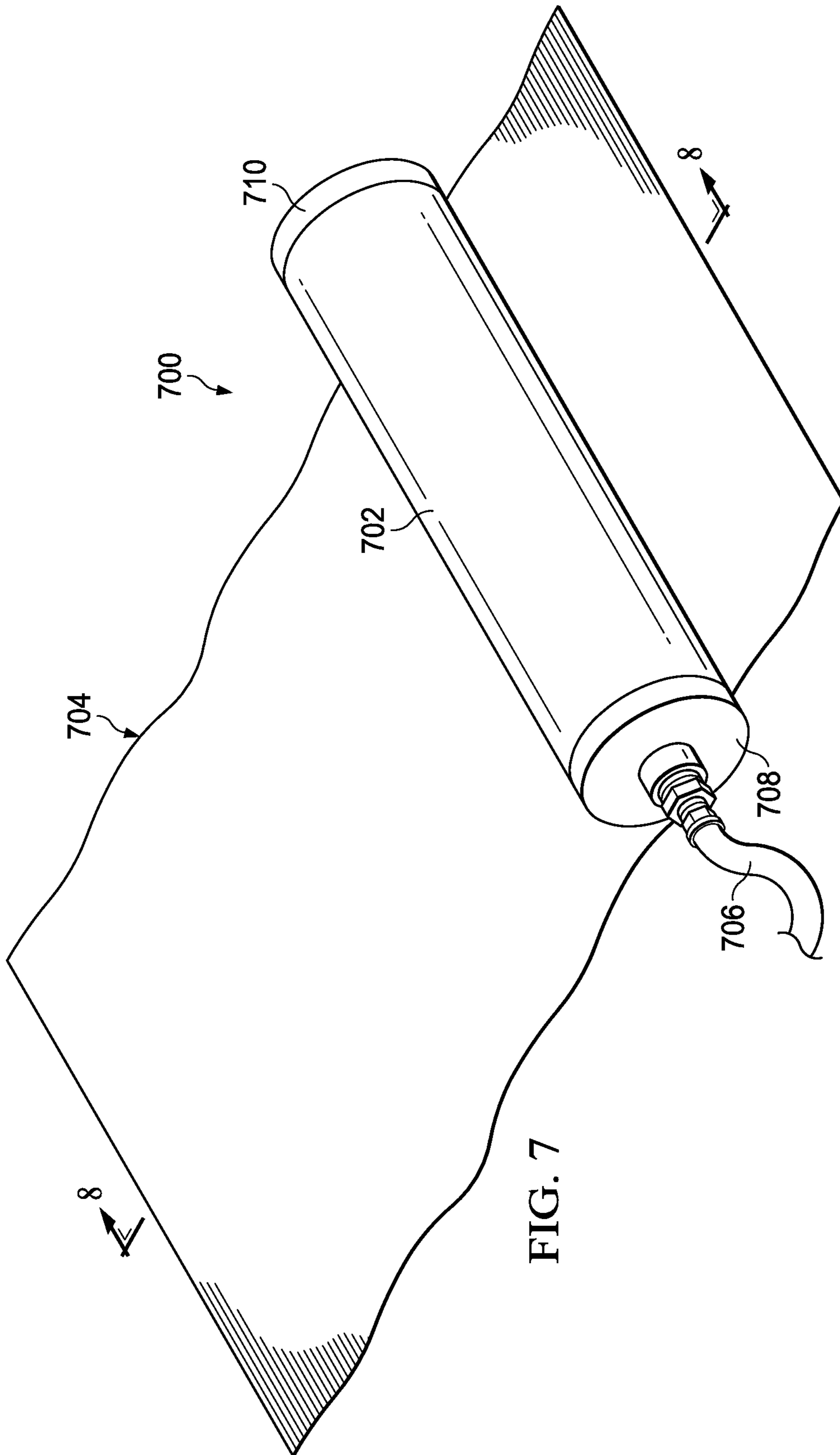
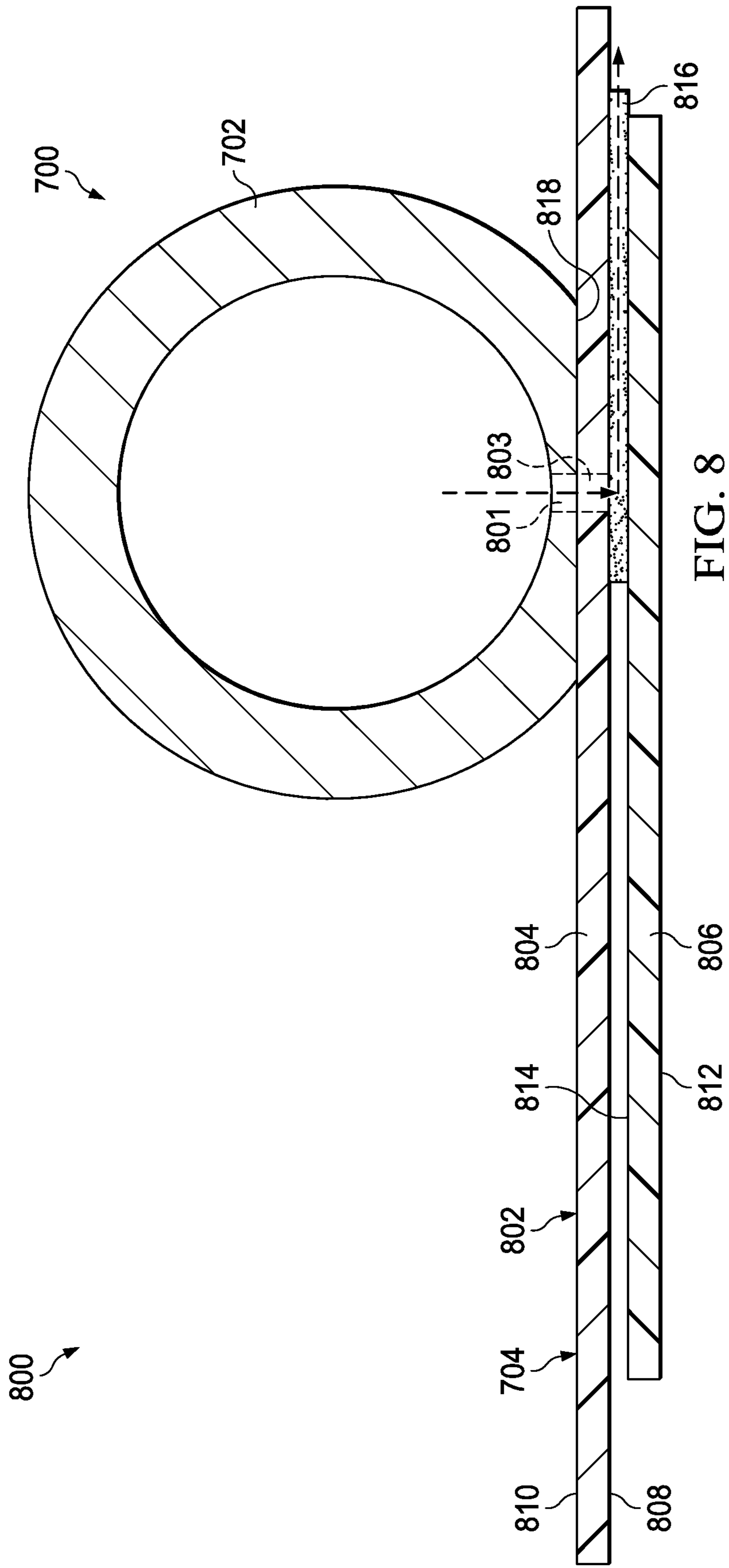

FIG. 7



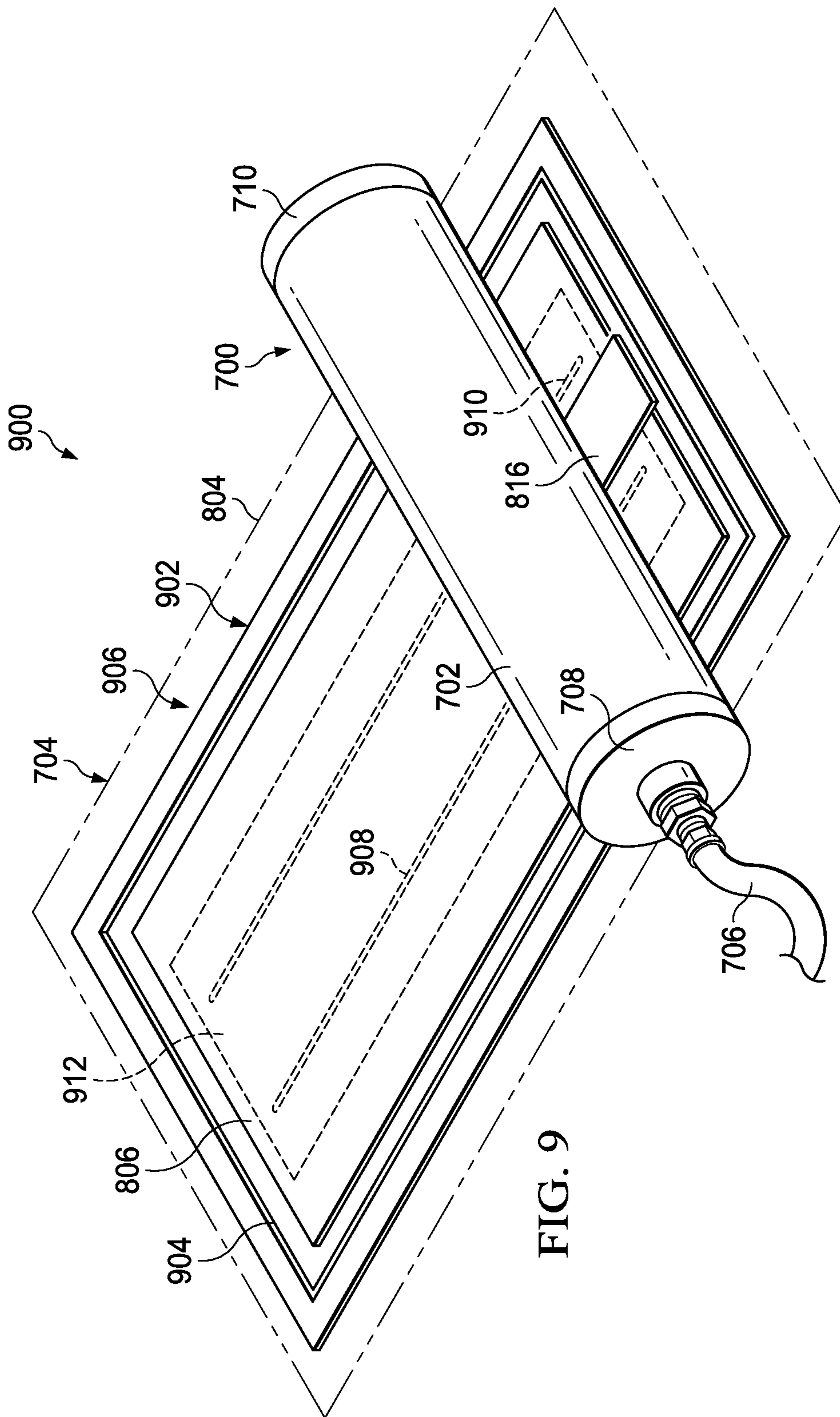

FIG. 9

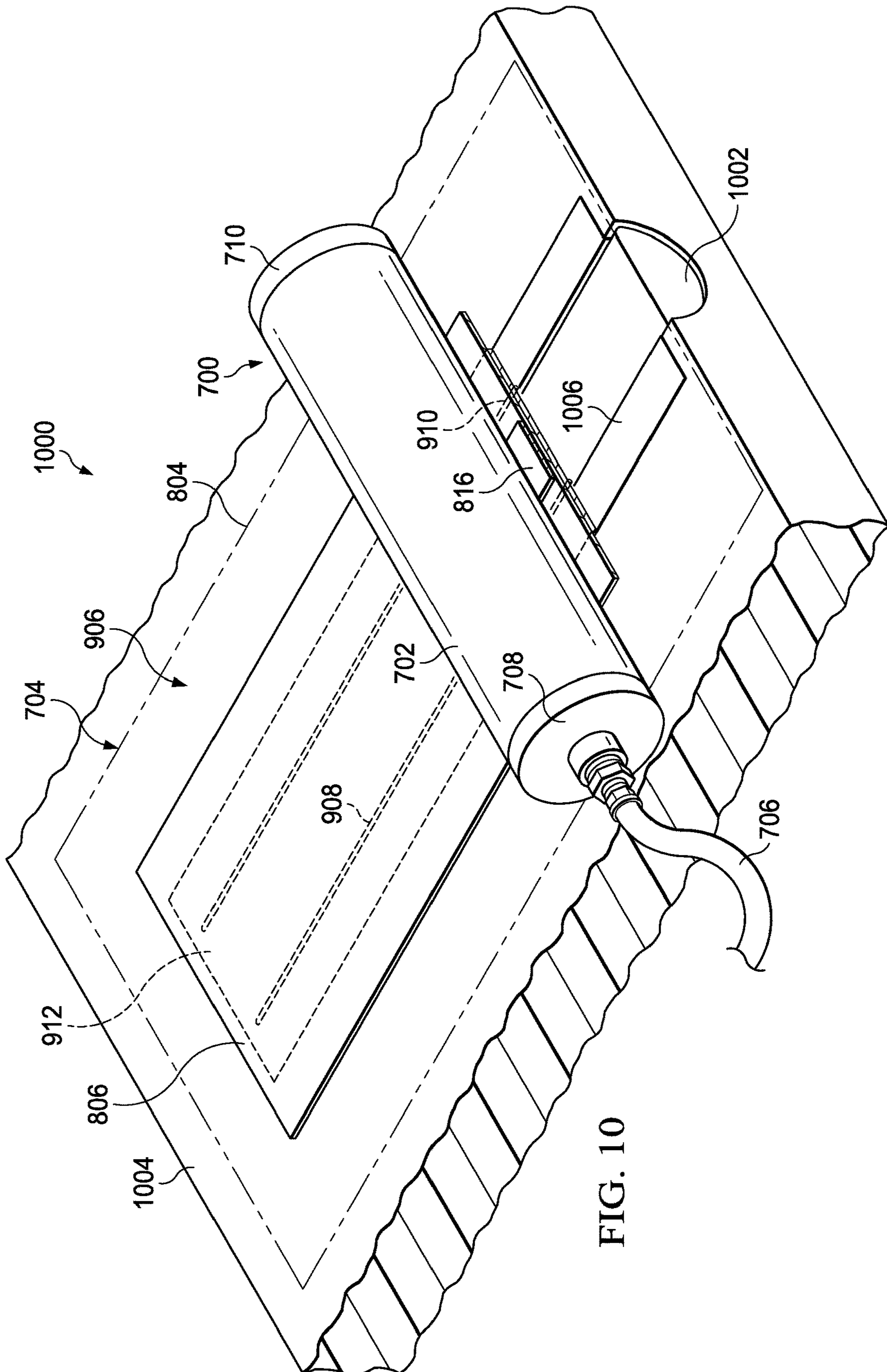

FIG. 10

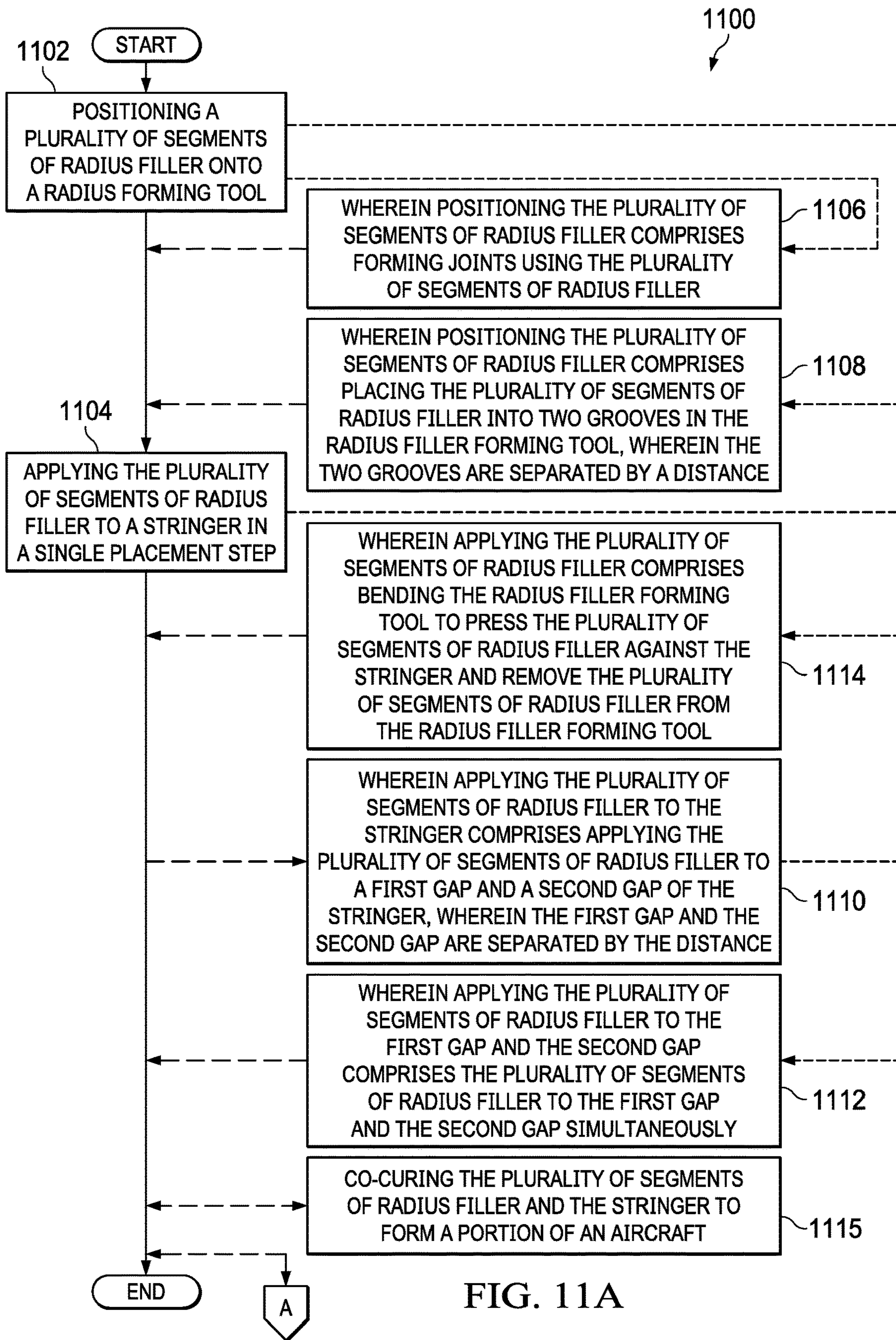

FIG. 11A

TO FIG. 11B

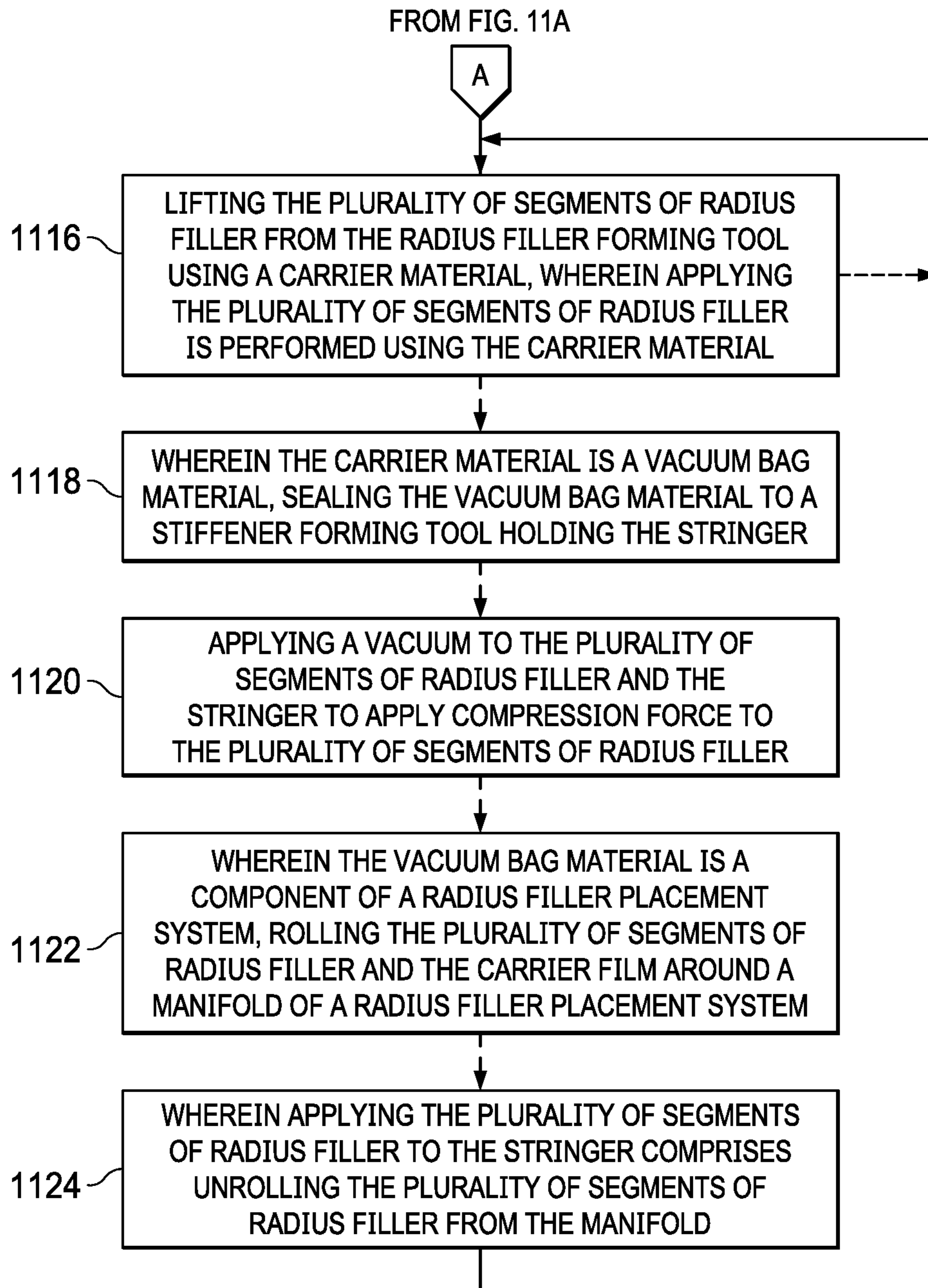
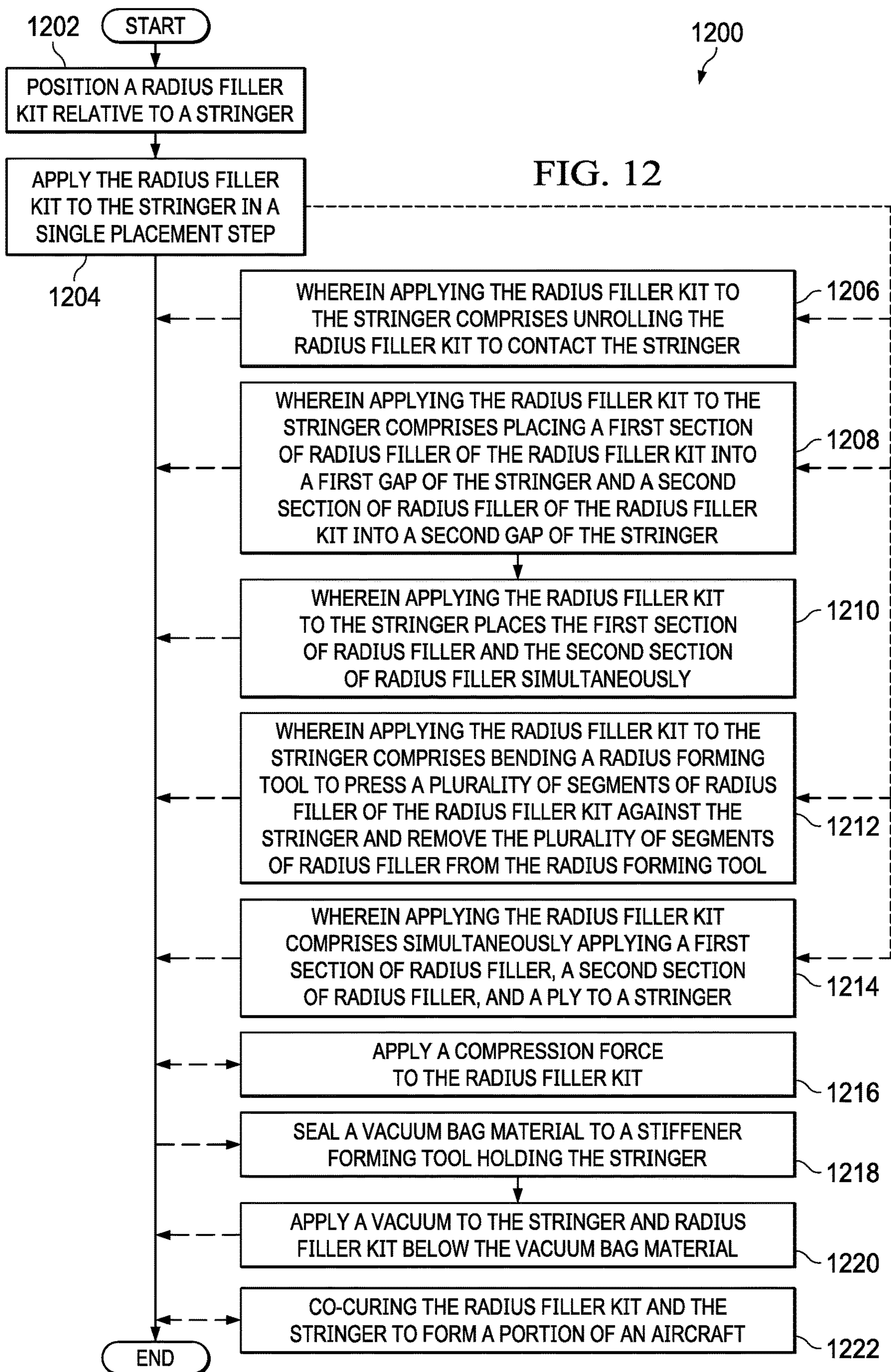
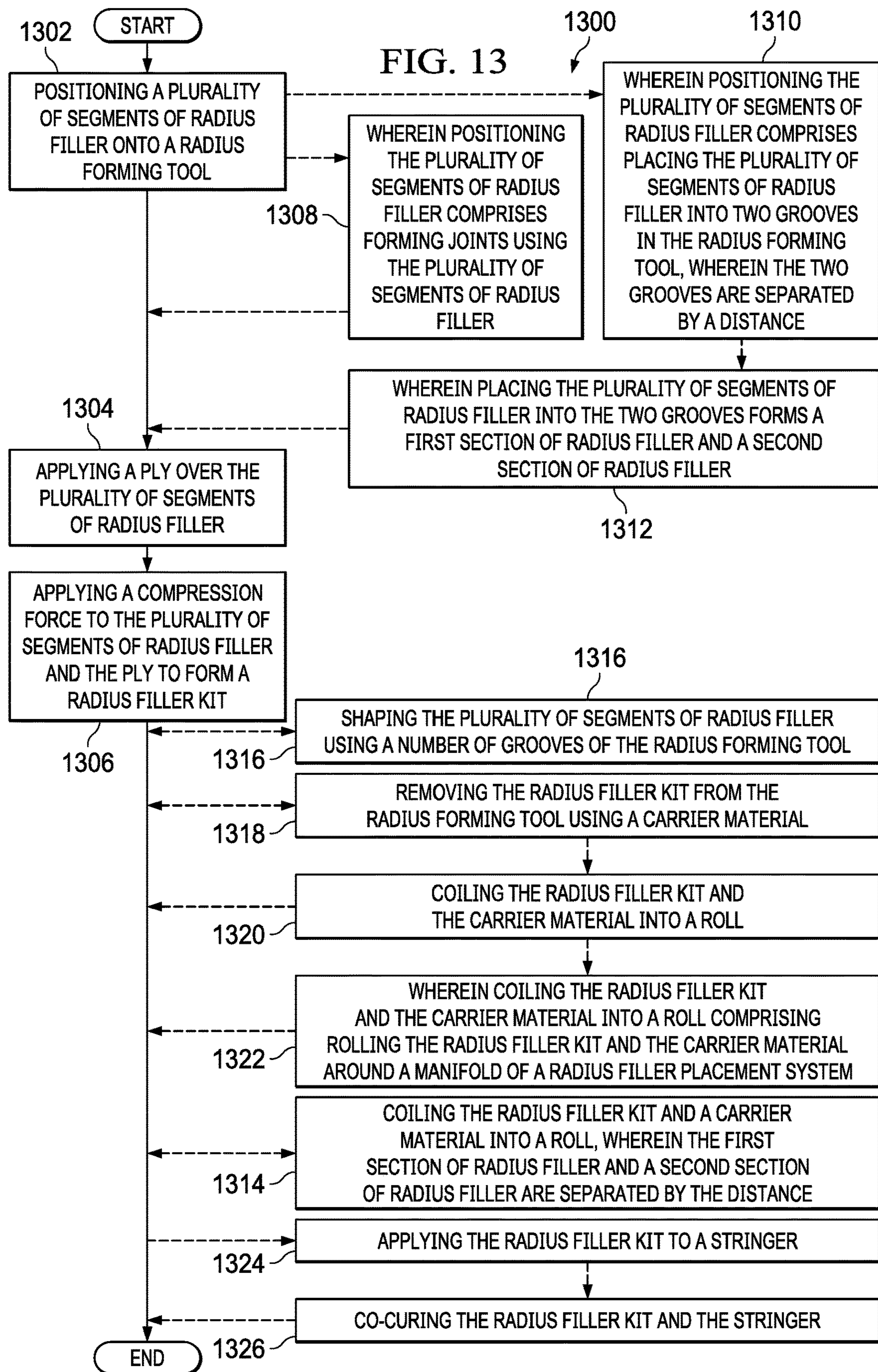

FIG. 11B





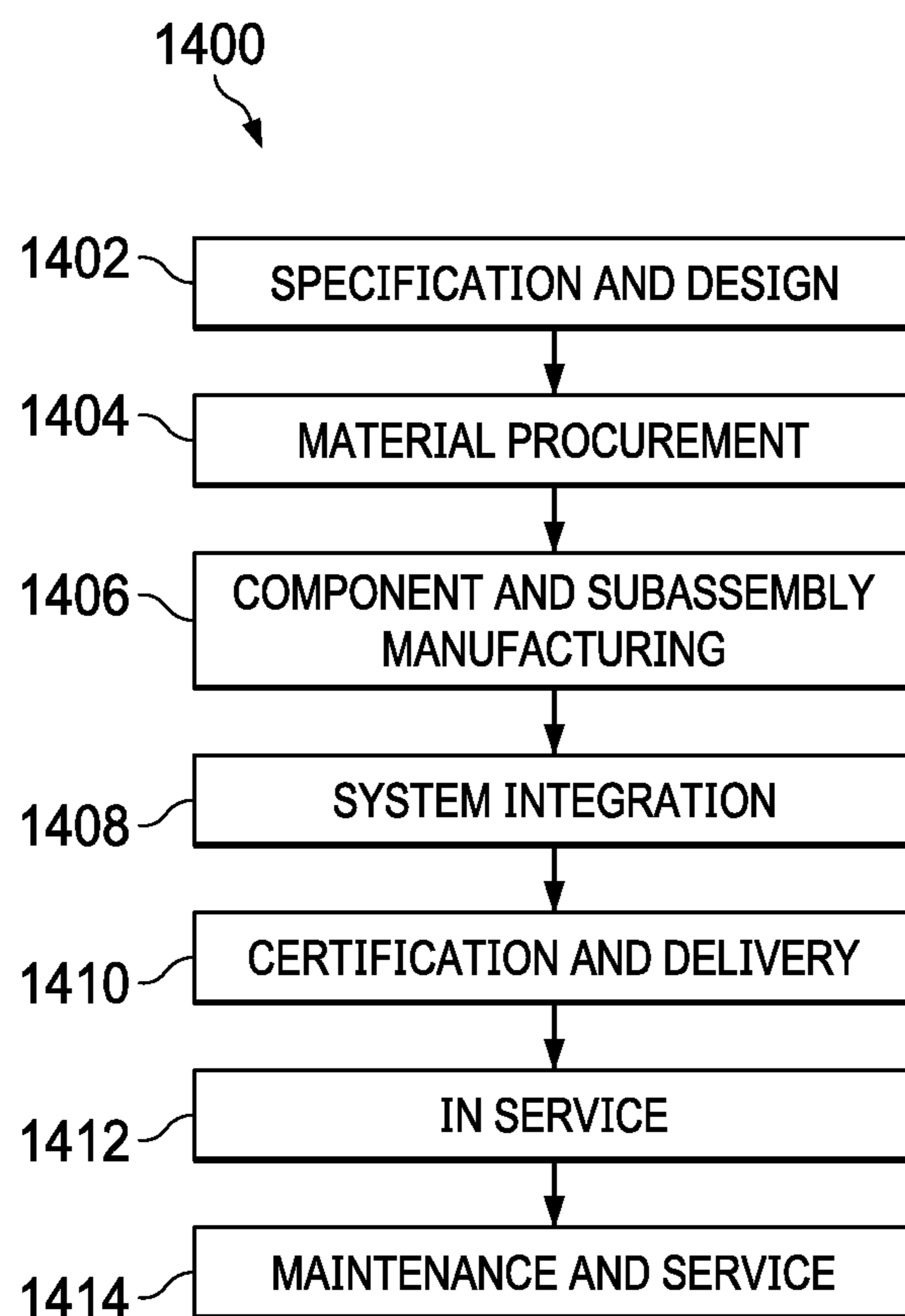

FIG. 14

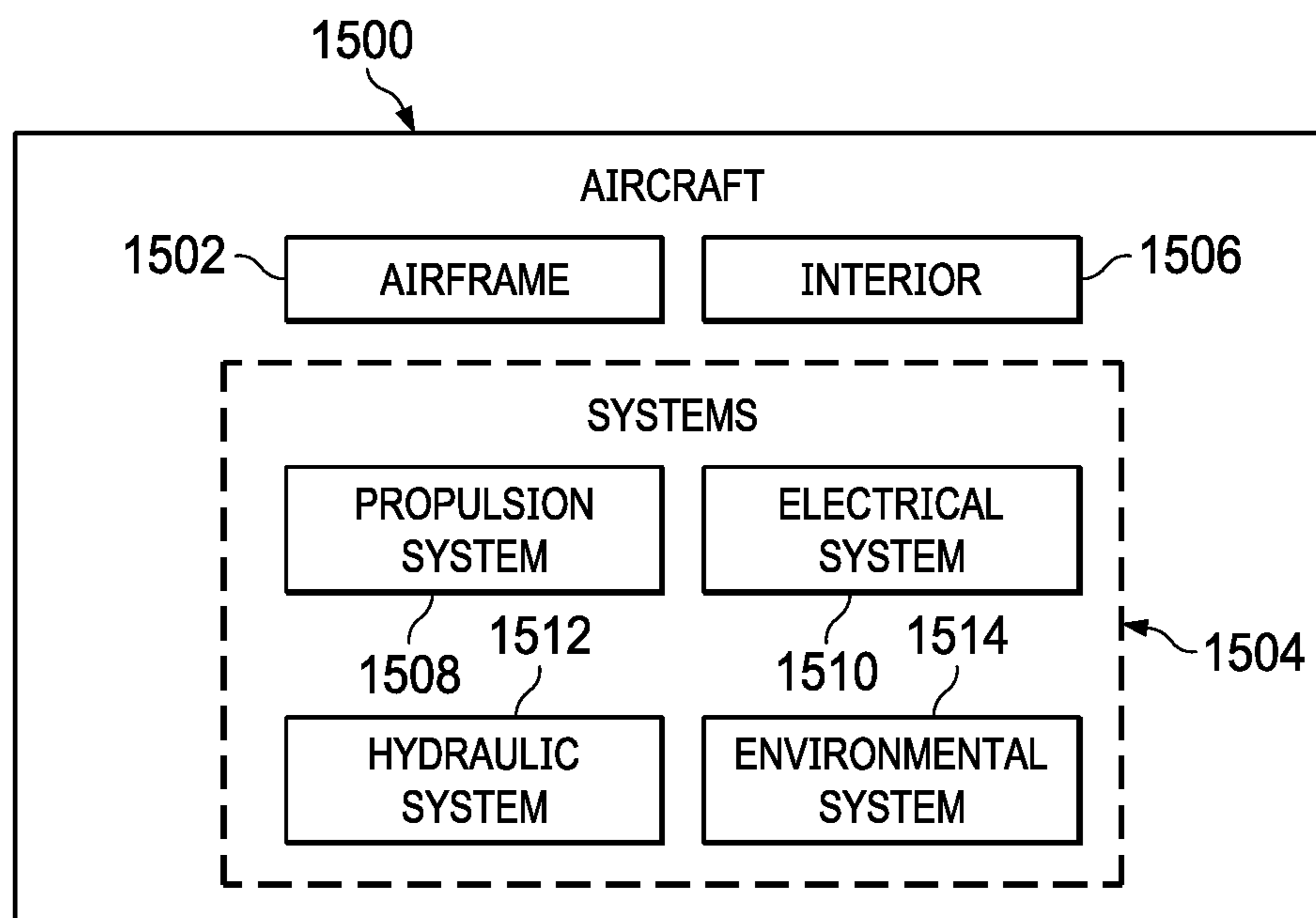

FIG. 15

METHOD AND APPARATUS FOR FORMING RADIUS FILLER KITS

BACKGROUND INFORMATION

1. Field

The present disclosure relates generally to laying up radius fillers and, more specifically, to laying up radius fillers substantially simultaneously. Yet more specifically, the present disclosure relates to forming radius filler kits for application to a composite layup.

2. Background

Radius fillers, also called “noodles,” are used to fill interfaces between plies in composite joints. Radius fillers are commonly used in joints for stiffeners, such as stringers. The radius being filled is created when a composite layup with a particular radius is joined with another composite layup.

Currently, radius fillers are applied to a composite layup directly by hand. Currently, radius fillers are applied individually to the composite layup. Applying radius fillers by hand may take more time than desired. Additionally, applying radius fillers by hand may be a less than desirable use of man power.

Therefore, it would be desirable to have a method and apparatus that take into account at least some of the issues discussed above, as well as other possible issues.

SUMMARY

An illustrative embodiment of the present disclosure provides a method. A plurality of segments of radius filler is positioned onto a radius filler forming tool. The plurality of segments of radius filler is applied to a stringer in a single placement step.

Another illustrative embodiment of the present disclosure provides a method. A radius filler kit is positioned relative to a stringer. The radius filler kit is applied to the stringer in a single placement step.

A further illustrative embodiment of the present disclosure provides a method. A plurality of segments of radius filler is positioned onto a radius filler forming tool. A ply is applied over the plurality of segments of radius filler. A compression force is applied to the plurality of segments of radius filler and the ply to form a radius filler kit.

A yet further illustrative embodiment of the present disclosure provides an apparatus. The apparatus comprises a roller manifold having a vacuum opening and a vacuum bag material connected to the roller manifold. The vacuum bag has an opening interfacing with the vacuum opening.

A yet further illustrative embodiment of the present disclosure provides a radius filler forming tool. The radius filler forming tool comprises a number of grooves in a surface and vacuum channels in the surface surrounding the number of grooves.

Another illustrative embodiment of the present disclosure provides an apparatus. The apparatus comprises a radius filler kit and a carrier material. The radius filler kit is on the carrier material. The radius filler kit comprises a plurality of segments of radius filler.

The features and functions can be achieved independently in various embodiments of the present disclosure or may be

combined in yet other embodiments in which further details can be seen with reference to the following description and drawings.

BRIEF DESCRIPTION OF THE DRAWINGS

The novel features believed characteristic of the illustrative embodiments are set forth in the appended claims. The illustrative embodiments, however, as well as a preferred mode of use, further objectives and features thereof, will best be understood by reference to the following detailed description of an illustrative embodiment of the present disclosure when read in conjunction with the accompanying drawings, wherein:

FIG. 1 is an illustration of a block diagram of a manufacturing environment in which radius fillers are laid up in accordance with an illustrative embodiment;

FIG. 2 is an illustration of a perspective view of radius fillers on a radius filler forming tool in accordance with an illustrative embodiment;

FIG. 3 is an illustration of a cross-sectional view of a stiffener forming tool for positioning stringers for a layup in accordance with an illustrative embodiment;

FIG. 4 is an illustration of a perspective view of a radius filler kit being positioned relative to a stringer in accordance with an illustrative embodiment;

FIG. 5 is an illustration of a perspective view of radius fillers and a ply on a radius filler forming tool in accordance with an illustrative embodiment;

FIG. 6 is an illustration of a perspective view of a radius filler kit being positioned relative to a stringer in accordance with an illustrative embodiment;

FIG. 7 is an illustration of an isometric view of a radius filler placement system having a manifold in accordance with an illustrative embodiment;

FIG. 8 is an illustration of a cross-sectional view of a radius filler placement system having a manifold in accordance with an illustrative embodiment;

FIG. 9 is an illustration of a radius filler placement system having a manifold sealed to a radius filler forming tool in accordance with an illustrative embodiment;

FIG. 10 is an illustration of a radius filler placement system having a manifold sealed to a tool holding a stringer in accordance with an illustrative embodiment;

FIGS. 11A and 11B are illustrations of a flowchart of a method for applying more than one segment of a radius filler to a stringer in accordance with an illustrative embodiment;

FIG. 12 is an illustration of a flowchart of a method for using a radius filler kit in accordance with an illustrative embodiment;

FIG. 13 is an illustration of a flowchart of a method for forming a radius filler kit in accordance with an illustrative embodiment;

FIG. 14 is an illustration of an aircraft manufacturing and service method in the form of a block diagram in accordance with an illustrative embodiment; and

FIG. 15 is an illustration of an aircraft in the form of a block diagram in which an illustrative embodiment may be implemented.

DETAILED DESCRIPTION

The illustrative embodiments recognize and take into account one or more different considerations. For example, the illustrative embodiments recognize and take into account that composite materials are tough, light-weight materials created by combining two or more functional components.

The illustrative embodiments recognize and take into account that a composite material may include reinforcing fibers bound in a polymer resin matrix. The illustrative embodiments recognize and take into account that the fibers may be unidirectional or may take the form of a woven cloth or fabric. The illustrative embodiments recognize and take into account that the fibers and resins are arranged and cured to form a composite material.

The illustrative embodiments recognize and take into account that using composite materials to create aerospace composite structures potentially allows for portions of an aircraft to be manufactured in larger pieces or sections. The illustrative embodiments recognize and take into account that a fuselage in an aircraft may be created in cylindrical sections and then assembled to form the fuselage of the aircraft.

The illustrative embodiments recognize and take into account that in some manufacturing processes for large composite parts, composite materials are laid up on a single large tool. The illustrative embodiments recognize and take into account that the large tool may be a manufacturing time limiting component.

The illustrative embodiments recognize and take into account that radius fillers (noodles) are currently hand installed into the cavities between stringer bladders and web/flange radii. The illustrative embodiments recognize and take into account that a ply, sometimes referred to as an inner mold line (IML) ply, is applied in a separate application step. The illustrative embodiments recognize and take into account that the ply is applied after a compaction step for the radii fillers. The illustrative embodiments recognize and take into account that an additional compaction step is performed for the ply after applying the ply over the radius filler.

The illustrative embodiments recognize and take into account that each application step on a tool adds flow to the assembly work on the tool. The illustrative embodiments recognize and take into account that each stringer includes radiuses that that are desirably filled. The illustrative embodiments recognize and take into account that applying each radius filler by hand may take an undesirable amount of time.

The illustrative embodiments recognize and take into account that laying radius fillers by hand onto the part may result in inconsistencies. The illustrative embodiments recognize and take into account that the inconsistencies may be introduced by placing unformed noodles into the gaps between a bladder and a stringer.

The illustrative embodiments recognize and take into account that radius fillers (noodles) are currently hand installed into the cavity in manageable (~6 ft) increments and then butted. The illustrative embodiments recognize and take into account that this radius filler application process is performed down the length of each stringer twice (one for each side of the stringer). The illustrative embodiments recognize and take into account that the manual radius filler application process may lead to an undesirable amount of on-part inspection (butt/gap requirements). The illustrative embodiments recognize and take into account that the manual radius filler application process adds flow time to the part on the tool.

Referring now to the figures and, in particular, with reference to FIG. 1, an illustration of a block diagram of a manufacturing environment in which radius fillers are laid up is depicted in accordance with an illustrative embodiment. In this figure, radius filler kit 100 is formed in manufacturing environment 102.

As depicted, radius filler kit 100 comprises first section of radius filler 104, second section of radius filler 106, and ply 108. First section of radius filler 104 and second section of radius filler 106 are separated by distance 110. In some illustrative examples, ply 108 is optional.

Distance 110 may be any desirable distance. In some illustrative examples, distance 110 is a single value across the length of first section of radius filler 104 and second section of radius filler 106. In other illustrative examples, distance 110 includes more than one value along the length of first section of radius filler 104 and second section of radius filler 106. In some illustrative examples, distance 110 may increase or decrease along the length of first section of radius filler 104 and second section of radius filler 106. When an increase or decrease is not present, distance 110 includes one value. When an increase or decrease is present, distance 110 includes two or more values.

The components of radius filler kit 100 are formed of a composite material. For example, each of first section of radius filler 104, second section of radius filler 106, and ply 108 may be formed of composite materials. Radius filler kit 100 may be formed of a thermoplastic composite material or a thermoset composite material.

Radius filler forming tool 112 is used to form radius filler kit 100. Radius filler forming tool 112 has number of grooves 114 in surface 116. As used herein, a "number of" items is one or more items. Here, "number of grooves 114" is one or more grooves. Vacuum channels 118 in surface 116 surround number of grooves 114. As depicted, number of grooves 114 includes groove 120 and groove 122.

Each of number of grooves 114 is configured to form a section of radius filler with a length equivalent to a length of a stringer in a layup. As depicted, radius filler forming tool 112 is used to form radius filler kit 100 for stringer 124 in layup 126. In some illustrative examples, each of number of grooves 114 has a length equivalent to length 128 of stringer 124 in layup 126. In one illustrative example, groove 120 has length 129 equivalent to length 128 and groove 122 has length 130 equivalent to length 128.

In some illustrative examples, groove 120 has length 129 greater than length 128, and groove 122 has length 130 greater than length 128. In these illustrative examples, groove 120 and groove 122 are used to form sections of radius filler each having length 128.

In some illustrative examples, length 129 and length 130 are substantially the same. In other illustrative examples, length 129 and length 130 may have different values.

To form radius filler kit 100, plurality of segments of radius filler 132 is positioned onto radius filler forming tool 112. Ply 108 is applied over plurality of segments of radius filler 132. Compression force 134 is applied to plurality of segments of radius filler 132 and ply 108 to form radius filler kit 100.

In illustrative examples in which ply 108 is not present in radius filler kit 100, compression force 134 is applied to plurality of segments of radius filler 132 after positioning plurality of segments of radius filler 132 onto radius filler forming tool 112.

When length 128 is greater than a provided manufactured length of radius filler, positioning plurality of segments of radius filler 132 includes forming joints 136 using plurality of segments of radius filler 132. For example, radius filler is provided in manufactured lengths. When manufactured length 138 of plurality of segments of radius filler 132 is shorter than length 128, first section of radius filler 104 will include at least one joint 140. In this illustrative example, at least one joint 140 is part of joints 136. When manufactured

length **138** of plurality of segments of radius filler **132** is shorter than length **128**, second section of radius filler **106** will include at least one joint **142**. In this illustrative example, at least one joint **142** is part of joints **136**.

Joints **136** take any desirable form. In some illustrative examples, joints **136** are butt joints. However, joints **136** may instead be any of at least one of a lap joint, a scarf joint, a step lap joint, or any other desirable type of joint.

Radius filler placement equipment **144** applies radius filler kit **100** to stringer **124**. Radius filler placement equipment **144** takes any desirable form. Radius filler placement equipment **144** may be operated manually, in an automated fashion, or some combination of the two. Radius filler placement equipment **144** performs at least one of lifting radius filler kit **100** from radius filler forming tool **112**, storing radius filler kit **100**, positioning radius filler kit **100** relative to stringer **124**, and applying radius filler kit **100** to stringer **124**.

In some illustrative examples, radius filler placement equipment **144** is pick and place equipment **146**. When radius filler placement equipment **144** is pick and place equipment **146**, pick and place equipment **146** may be operated manually, in an automated fashion, or some combination of the two. In these illustrative examples, pick and place equipment **146** lifts radius filler kit **100** from radius filler forming tool **112** and places radius filler kit **100** onto stringer **124**. When pick and place equipment **146** is used to lift and place radius filler kit **100**, additional equipment may be present in manufacturing environment **102** to apply compression force **134** to form radius filler kit **100**.

In other illustrative examples, radius filler placement equipment **144** is radius filler forming tool **112**. When radius filler placement equipment **144** is radius filler forming tool **112**, radius filler forming tool **112** comprises flexible material **148**. In some illustrative examples, flexible material **148** is flexible about a line (not depicted) perpendicular to number of grooves **114** in surface **116**.

When radius filler forming tool **112** has flexible material **148**, radius filler forming tool **112** may be bent to apply radius filler kit **100** to stringer **124** and remove radius filler kit **100** from radius filler forming tool **112** substantially simultaneously. For example, compression is applied to at least a portion of radius filler forming tool **112** to press radius filler kit **100** to stringer **124**. After applying compression, radius filler forming tool **112** is bent away from stringer **124** to “peel” radius filler forming tool **112** from radius filler kit **100**.

In other illustrative examples, radius filler placement equipment **144** takes the form of carrier material **150**. In some illustrative examples, carrier material **150** may be a component of radius filler placement equipment **144**. Carrier material **150** may be used manually, in conjunction with automated or partially automated equipment, or some combination of the two. Carrier material **150** is formed of any desirable material configured to lift radius filler kit **100** and apply radius filler kit **100** to stringer **124**. In some illustrative examples, carrier material **150** is selected to be reusable. In some illustrative examples, carrier material **150** lifts and applies radius filler kit **100** using a mechanical compressive force.

In other illustrative examples, carrier material **150** takes the form of vacuum bag material **152**. When carrier material **150** takes the form of vacuum bag material **152**, a vacuum (not depicted) may be pulled underneath carrier material **150** to lift and apply radius filler kit **100**. Vacuum bag material **152** is formed of any desirable material configured to hold a vacuum, lift radius filler kit **100**, and apply radius filler kit

100 to stringer **124**. In some illustrative examples, vacuum bag material **152** is selected to be reusable.

In some illustrative examples, vacuum bag material **152** is configured to lift a composite material. The composite material may take any desirable form. In some illustrative examples, the composite material includes a ply, such as ply **108** of FIG. **1**. In some illustrative examples, the composite material includes a plurality of segments of radius filler **132** of FIG. **1**. In some illustrative examples, the composite material includes radius filler kit **100** of FIG. **1**.

In some illustrative examples, carrier material **150** and radius filler kit **100** may be transported substantially planar. For example, carrier material **150** and radius filler kit **100** may be transported on a conveyor or on a table. In some illustrative examples, carrier material **150** and radius filler kit **100** are coiled into roll **153**.

In some illustrative examples, carrier material **150** is a component of radius filler placement system **154**. Radius filler placement system **154** may be used manually, in an automated fashion, or some combination of the two. Radius filler placement system **154** comprises roller manifold **156** having vacuum opening **158** and vacuum bag material **152** connected to roller manifold **156**. Vacuum bag material **152** has opening **160** interfacing with vacuum opening **158**.

In some illustrative examples, vacuum bag material **152** comprises first vacuum bag layer **162** and second vacuum bag layer **164**. First vacuum bag layer **162** creates a vacuum seal with radius filler forming tool **112**. Second vacuum bag layer **164** lifts and holds radius filler kit **100**. First vacuum bag layer **162** and second vacuum bag layer **164** are formed of any desirable type of material. In some illustrative examples, first vacuum bag layer **162** and second vacuum bag layer **164** are formed of the same type of material. In other illustrative examples, first vacuum bag layer **162** and second vacuum bag layer **164** are formed of different materials.

In some illustrative examples vacuum bag material **152** comprises first latex sheet **166**. First latex sheet **166** may be an implementation of first vacuum bag layer **162**. In some illustrative examples, vacuum bag material **152** further comprises second latex sheet **168**. Second latex sheet **168** may be an implementation of second vacuum bag layer **164**.

In some illustrative examples, second latex sheet **168** is bonded to first latex sheet **166**. Second latex sheet **168** is bonded to first latex sheet **166** using any desirable method. Bonds **170** between first latex sheet **166** and second latex sheet **168** may be formed using epoxy, fasteners, welding, or any other desirable method.

As depicted, breather **172** is positioned between first latex sheet **166** and second latex sheet **168**. Breather **172** is in vacuum communication with vacuum opening **158**. Breather **172** distributes vacuum from vacuum opening **158** to edges of first latex sheet **166** to seal first latex sheet **166** against a tool or layup, such as radius filler forming tool **112** or layup **126**.

In some illustrative examples, first latex sheet **166** and second latex sheet **168** are configured to roll around roller manifold **156**. First latex sheet **166** and second latex sheet **168** are configured to form roll **153** with radius filler kit **100**. In these illustrative examples, first latex sheet **166** and second latex sheet **168** are configured to prevent undesirable sticking to roller manifold **156** or radius filler kit **100**.

In some illustrative examples, first latex sheet **166** and second latex sheet **168** each have a respective mesh surface. The respective mesh surface prevents undesirable sticking. For example, a respective mesh surface of first latex sheet **166** prevents first latex sheet **166** from undesirably sticking

to roller manifold **156** or radius filler kit **100**. As another example, a respective mesh surface of second latex sheet **168** prevents second latex sheet **168** from undesirably sticking to first latex sheet **166**.

Roller manifold **156** has any desirable size and shape. In some illustrative examples, roller manifold **156** is cylindrical **173**.

In some illustrative examples, roller manifold **156** has machined surface **174**. When machined surface **174** is present, vacuum bag material **152** is connected to machined surface **174**. For example, first vacuum bag layer **162** is connected to machined surface **174**. Machined surface **174** creates a larger surface area for connecting vacuum bag material **152** to roller manifold **156**.

When roller manifold **156** has machined surface **174**, vacuum opening **158** is within machined surface **174**. Machined surface **174** aids in orienting vacuum opening **158** relative to radius filling forming tool **112** or layup **126**.

Roller manifold **156** forms vacuum chamber **176**. Vacuum equipment **178** provides vacuum to vacuum chamber **176** of roller manifold **156**. Vacuum travels from vacuum chamber **176** through vacuum opening **158** and opening **160** to beneath first vacuum bag layer **162**.

Vacuum beneath first vacuum bag layer **162** seals first vacuum bag layer **162** to one of radius filler kit **100** or layup **126**. Vacuum beneath first vacuum bag layer **162** applies compression force **134** to radius filler kit **100** on radius filler forming tool **112**.

In some illustrative examples, a heating element is associated with radius filler placement system **154**. A heating element may be used to heat composite material of radius filler kit **100**. Heating radius filler kit **100** affects at least one of the flexibility or the tackiness of the composite material of radius filler kit **100**. At least one of flexibility or tackiness of the composite material of radius filler kit **100** affects at least one of adhesion to carrier material **150**, adhesion to stringer **124**, or coiling into or out of roll **153**.

In some illustrative examples, roller manifold **156** has heating element **171**. In other illustrative examples, vacuum bag material **152** has integrated heating elements **179**.

Radius filler placement system **154** may be used as a carrier, a roller, a backing paper, and a compaction bag. Radius filler placement system **154** lifts radius filler kit **100** to act as a carrier. In some illustrative examples, carrier material **150** and radius filler kit **100** form roll **153** and radius filler placement system **154** acts as a roller. Radius filler placement system **154** acts as a backing paper to apply radius filler kit **100** to stringer **124** of layup **126**.

Layup **126** is formed on stiffener forming tool **180**. Stringer **124** is positioned in channel **182** of stiffener forming tool **180**. Bladder **184** is positioned in stringer **124** to maintain the shape of stringer **124**.

Radius filler placement equipment **144** applies plurality of segments of radius filler **132** to stringer **124**. Radius filler placement equipment **144** applies plurality of segments of radius filler **132** to first gap **186** and second gap **188** of stringer **124**. First gap **186** and second gap **188** are separated by distance **110**.

As depicted, applying plurality of segments of radius filler **132** to first gap **186** and second gap **188** comprises applying plurality of segments of radius filler **132** to first gap **186** and second gap **188** simultaneously. In some illustrative examples, applying radius filler kit **100** to stringer **124** comprises placing first section of radius filler **104** of radius filler kit **100** into first gap **186** of stringer **124** and second section of radius filler **106** of radius filler kit **100** into second gap **188** of stringer **124**.

In some illustrative examples, radius filler placement system **154** acts as backing paper to position and apply radius filler kit **100** to stringer **124**. After applying radius filler kit **100** to stringer **124**, radius filler placement system **154** acts as a compaction bag to apply pressure to radius filler kit **100**.

As used herein, the phrase “at least one of,” when used with a list of items, means different combinations of one or more of the listed items may be used, and only one of each item in the list may be needed. In other words, “at least one of” means any combination of items and number of items may be used from the list, but not all of the items in the list are required. The item may be a particular object, a thing, or a category.

This example also may include item A, item B, and item C, or item B and item C. Of course, any combination of these items may be present. In other examples, “at least one of” may be, for example, without limitation, two of item A, one of item B, and ten of item C; four of item B and seven of item C; or other suitable combinations.

The illustration of manufacturing environment **102** in FIG. **1** is not meant to imply physical or architectural limitations to the manner in which an illustrative embodiment may be implemented. Other components in addition to or in place of the ones illustrated may be used. Some components may be unnecessary. Also, the blocks are presented to illustrate some functional components. One or more of these blocks may be combined, divided, or combined and divided into different blocks when implemented in an illustrative embodiment.

For example, although radius filler placement system **154** is described for use with radius filler kit **100**, radius filler placement system **154** may be used to place any desirable type of composite material. For example, radius filler placement system **154** may instead be referred to as a composite placement system or composite placement apparatus. In some illustrative examples, radius filler placement system **154** may be used to position and place plies of composite material (not depicted). In some illustrative examples, radius filler placement system **154** may be used to coil and store plies of composite material (not depicted).

Turning now to FIG. **2**, an illustration of a perspective view of radius fillers on a radius filler forming tool is depicted in accordance with an illustrative embodiment. Radius filler forming tool **200** is a physical implementation of radius filler forming tool **112** of FIG. **1**. Plurality of segments of radius filler **202** has been positioned onto radius filler forming tool **200**. Plurality of segments of radius filler **202** is a physical implementation of plurality of segments of radius filler **132** of FIG. **1**.

In this illustrative example, plurality of segments of radius filler **202** has been placed into number of grooves **204** in surface **206** of radius filler forming tool **200**. As depicted, plurality of segments of radius filler **202** include radius filler **208** placed into groove **210** of number of grooves **204** and radius filler **212** placed into groove **214** of number of grooves **204**.

Groove **210** and groove **214** are separated by distance **216**. As depicted, radius filler **208** and radius filler **212** are separated by distance **216**. Distance **216** is equivalent to a distance between a first gap and a second gap of a stringer, such as stringer **402** of FIG. **4** or stringer **602** of FIG. **6**. As depicted, distance **216** has a constant or substantially constant value. However, in other non-depicted illustrative examples, distance **216** has multiple values. When distance **216** has multiple values, radius filler **208** and radius filler **212** are not parallel.

In some illustrative examples, number of grooves **204** in surface **206** is configured to shape plurality of segments of radius filler **202**. In one illustrative example, number of grooves **204** in surface **206** is configured to shape plurality of segments of radius filler **202** to a domed cross-sectional shape. In another illustrative example, number of grooves **204** in surface **206** is configured to shape plurality of segments of radius filler **202** to a triangular cross-sectional shape. Number of grooves **204** in surface **206** may shape plurality of segments of radius filler **202** when compressive force is applied to plurality of segments of radius filler **202**.

Vacuum channels **218** in surface **206** surround number of grooves **204**. Vacuum channels **218** are used to form a seal around number of grooves **204** to apply vacuum to plurality of segments of radius filler **202**.

Turning now to FIG. 3, an illustration of a cross-sectional view of a stiffener forming tool for positioning stringers for a layup is depicted in accordance with an illustrative embodiment. Stiffener forming tool **300** is a physical implementation of stiffener forming tool **180** of FIG. 1. As depicted, stiffener forming tool **300** has plurality of channels **302**.

A stringer is laid up in each of plurality of channels **302**. After laying up a stringer in a respective channel of plurality of channels **302**, radius fillers are applied to gaps of the respective stringer.

Laying up stringers and radius fillers in each of plurality of channels **302** of stiffener forming tool **300** by hand is a time-limiting step. Applying radius fillers as a radius filler kit will reduce the time spent applying radius fillers to stiffener forming tool **300**. For example, applying plurality of segments of radius filler **132** of FIG. 1 as radius filler kit **100** to stiffener forming tool **300** will reduce the time spent applying plurality of radius filler **132** to stiffener forming tool **300**.

The illustration of stiffener forming tool **300** in FIG. 3 is not meant to imply physical or architectural limitations to the manner in which an illustrative embodiment may be implemented. Other components in addition to or in place of the ones illustrated may be used. Some components may be unnecessary. Also, the blocks are presented to illustrate some functional components. One or more of these blocks may be combined, divided, or combined and divided into different blocks when implemented in an illustrative embodiment.

For example, although stiffener forming tool **300** has a circular cross-section, a stiffener forming tool may have any desirable shape. As another example, although stiffener forming tool **300** has channels **302**, a stiffener forming tool may have any desirable size, quantity, or shape of channels.

Turning now to FIG. 4, an illustration of a perspective view of a radius filler kit being positioned relative to a stringer is depicted in accordance with an illustrative embodiment. In FIG. 4, stringer **402** has been placed in one of plurality of channels **302** of stiffener forming tool **300** of FIG. 3. More specifically, stringer **402** is within channel **404** of stiffener forming tool **300**. Radius filler kit **400** is a physical implementation of radius filler kit **100** of FIG. 1. Radius filler kit **400** is positioned relative to stringer **402**. Stringer **402** is a physical implementation of stringer **124** of FIG. 1.

Bladder **406** is positioned within stringer **402**. Bladder **406** maintains shape **408** of stringer **402** during curing.

Radius filler kit **400** is positioned relative to stringer **402**. Radius filler kit **400** comprises plurality of segments of radius filler **409**. Plurality of segments of radius filler **409** form first section of radius filler **410** and second section of

radius filler **414**. Radius filler kit **400** is positioned such that first section of radius filler **410** will be placed into first gap **412** of stringer **402**. Radius filler kit **400** is positioned such that second section of radius filler **414** will be placed into second gap **416** of stringer **402**.

Radius filler kit **400** is applied to stringer **402** by lowering carrier material **418** towards stringer **402**. Radius filler kit **400** is lowered such that plurality of segments of radius filler **409** is applied to first gap **412** and second gap **416** of stringer **402**. First gap **412** and second gap **416** are separated by distance **420**. First section of radius filler **410** and second section of radius filler **414** on carrier material **418** are separated by distance **420** prior to application to stringer **402**.

Plurality of segments of radius filler **409** is applied to first gap **412** and second gap **416** simultaneously. Radius filler kit **400**, including first section of radius filler **410** and second section of radius filler **414**, is lowered such that first section of radius filler **410** is applied to first gap **412** and second section of radius filler **414** is applied to second gap **416** simultaneously.

Carrier material **418** and radius filler kit **400** are lowered towards stiffener forming tool **300** to apply radius filler kit **400** to stringer **402**. In some illustrative examples, carrier material **418** holding radius filler kit **400** may be transported in a substantially planar state. In other illustrative examples, carrier material **418** holding radius filler kit **400** may be transported in a rolled state. In some illustrative examples, applying plurality of segments of radius filler **409** comprises unrolling carrier material **418** and radius filler kit **400**. In other illustrative examples, carrier material **418** and radius filler kit **400** are unrolled after transportation but prior to application of radius filler kit **400** to stringer **402**.

After applying radius filler kit **400** to stringer **402**, a compression force is applied to create a greater adhesive force between radius filler kit **400** and stringer **402** than between radius filler kit **400** and carrier material **418**. When the adhesive force between radius filler kit **400** and stringer **402** is greater than the adhesive force between radius filler kit **400** and carrier material **418**, carrier material **418** may be removed from radius filler kit **400**. When carrier material **418** is removed from radius filler kit **400**, first section of radius filler **410** remains in first gap **412** and second section of radius filler **414** remains in second gap **416**.

In some illustrative examples, carrier material **418** is a vacuum bag material. When carrier material **418** is a vacuum bag material, the vacuum bag material may be sealed to stiffener forming tool **300** holding stringer **402** after applying radius filler kit **400** to stringer **402**. In these illustrative examples, a vacuum may be applied to plurality of segments of radius filler **409** and stringer **402** to apply the compression force to plurality of segments of radius filler **409**. After applying the vacuum, carrier material **418** is removed.

In some illustrative examples, plurality of segments of radius filler **409** and stringer **402** may be cured prior to removing carrier material **418**. In other illustrative examples, plurality of segments of radius filler **409** and stringer **402** are cured after removing carrier material **418**. For example, plurality of segments of radius filler **409** and stringer **402** may be components of a larger composite layup. In this example, after positioning the other components of the larger composite layup, the composite layup is co-cured as a whole. For example, plurality of segments of radius filler **409** and stringer **402** may be components of a barrel section of an aircraft. In this illustrative example, the

barrel section may be cured after a composite skin is placed over plurality of segments of radius filler 409 and stringer 402.

The illustration of radius filler kit 400, carrier material 418, and stiffener forming tool 300 in FIG. 4 are not meant to imply physical or architectural limitations to the manner in which an illustrative embodiment may be implemented. Other components in addition to or in place of the ones illustrated may be used. Some components may be unnecessary.

As discussed, channel 404 is a portion of stiffener forming tool 300. In other illustrative examples, channel 404 may be a portion of a stiffener forming tool having a different size, shape, or quantity of channels. Radius filler kit 400 is depicted as having two radius filler sections. In other illustrative examples, radius filler kit 400 may have greater than two radius filler sections.

As another example, first section of radius filler 410 and second section of radius filler 414 have domed cross-sectional shape 422. In other non-depicted illustrative examples, first section of radius filler 410 and second section of radius filler 414 may have other desirable shapes. For example, first section of radius filler 410 and second section of radius filler 414 may have a triangular cross-sectional shape.

Radius filler kit 400 may be positioned and applied to stringer 404 in any desirable fashion such as manually, in an automated fashion, or some combination of the two. For example, carrier material 418 may be maneuvered manually or using automated equipment. In some illustrative examples, a compression force is applied to radius filler kit 400 manually. In some illustrative examples, a compression force is applied to radius filler kit 400 in an automated fashion.

Turning now to FIG. 5, an illustration of a perspective view of radius fillers and a ply on a radius filler forming tool is depicted in accordance with an illustrative embodiment. Radius filler forming tool 500 is a physical implementation of radius filler forming tool 112. Plurality of segments of radius filler 502 have been positioned onto radius filler forming tool 200. Plurality of segments of radius filler 502 is a physical implementation of plurality of segments of radius filler 132 of FIG. 1.

Radius filler forming tool 500 is a physical implementation of radius filler forming tool 112 of FIG. 1. Plurality of segments of radius filler 502 have been positioned onto radius filler forming tool 500. Plurality of segments of radius filler 502 is a physical implementation of plurality of segments of radius filler 132 of FIG. 1.

In this illustrative example, plurality of segments of radius filler 502 have been placed into number of grooves 504 in surface 506 of radius filler forming tool 500. As depicted, plurality of segments of radius filler 502 include radius filler 508 placed into groove 510 of number of grooves 504 and radius filler 512 placed into groove 514 of number of grooves 504.

As depicted, radius filler 508 includes three portions of radius filler joined by joint 516 and joint 518. As depicted, radius filler 512 includes three portions of radius filler joined by joint 520 and joint 522.

Groove 510 and groove 514 are separated by distance 524. As depicted, radius filler 508 and radius filler 512 are separated by distance 524. Distance 524 is equivalent to a distance between a first gap and a second gap of a stringer, such as stringer 602 of FIG. 6. As depicted, distance 524 has a constant or substantially constant value. However, in other non-depicted illustrative examples, distance 524 has mul-

iple values. When distance 524 has multiple values, radius filler 508 and radius filler 512 are not parallel.

In some illustrative examples, number of grooves 504 in surface 506 is configured to shape plurality of segments of radius filler 502. In one illustrative example, number of grooves 504 in surface 506 is configured to shape plurality of segments of radius filler 502 into a domed cross-sectional shape. In another illustrative example, number of grooves 504 in surface 506 is configured to shape plurality of segments of radius filler 502 into a triangular cross-sectional shape. Number of grooves 504 in surface 506 may shape plurality of segments of radius filler 502 when a compressive force is applied to plurality of segments of radius filler 502.

As depicted, ply 526 is being laid over plurality of segments of radius filler 502. After applying ply 526 over plurality of segments of radius filler 502, a compression force is applied to plurality of segments of radius filler 502 and ply 526 to form a radius filler kit. After forming the radius filler kit, the radius filler kit is applied to a stringer, such as stringer 402 of FIG. 4 or stringer 602 of FIG. 6. A compression force may be applied in any desirable way. In some illustrative examples, the compression force is a mechanical compression force. In other illustrative examples, the compression force is a pneumatic compression force, such as applying a vacuum.

In some illustrative examples, the radius filler kit, including ply 526 and plurality of segments of radius filler 502, is positioned and applied onto a stringer using radius filler forming tool 500. In these illustrative examples, radius filler forming tool 500 includes a flexible material. In these illustrative examples, the flexible material is flexible about a line perpendicular to number of grooves 504 in surface 506. In other illustrative examples with different curvatures, the flexible material may be flexible in any desired direction.

In other illustrative examples, the radius filler kit, including ply 526 and plurality of segments of radius filler 502, is removed from radius filler forming tool 500 using a carrier material (not depicted). In some illustrative examples, the carrier material is a vacuum bag material. In these illustrative examples, the vacuum bag material may be used to apply a vacuum to the radius filler kit on radius filler forming tool 500 and to apply the radius filler kit to a stringer.

Vacuum channels 528 in surface 506 surround number of grooves 504. Vacuum channels 528 are used to form a seal around number of grooves 504 to apply vacuum to ply 526 and plurality of segments of radius filler 502.

In some illustrative examples, the carrier material may be a component of a radius filler placement system, such as radius filler placement system 154 of FIG. 1. In other illustrative examples, a pick and place machine is used to remove the radius filler kit from radius filler forming tool 500 and place the radius filler kit onto a stringer.

Turning now to FIG. 6, an illustration of a perspective view of a radius filler kit being positioned relative to a stringer is depicted in accordance with an illustrative embodiment. Radius filler kit 600 is a physical implementation of radius filler kit 100 of FIG. 1. Radius filler kit 600 is positioned relative to stringer 602. Stringer 602 is a physical implementation of stringer 124 of FIG. 1.

As depicted, stringer 602 is within channel 604 of stiffener forming tool 605. Stiffener forming tool 605 may be a physical implementation of stiffener forming tool 180 of FIG. 1. Stiffener forming tool 605 may be a portion of stiffener forming tool 300 of FIG. 3. When stiffener forming tool 605 is a portion of stiffener forming tool 300, stringer

602 has been placed in one of plurality of channels 302 of stiffener forming tool 300 of FIG. 3.

Bladder 606 is positioned within stringer 602. Bladder 606 maintains shape 608 of stringer 602 during curing.

Radius filler kit 600 is positioned relative to stringer 602. Radius filler kit 600 comprises plurality of segments of radius filler 609. Plurality of segments of radius filler 609 forms first section of radius filler 610 and second section of radius filler 614. Radius filler kit 600 is positioned such that first section of radius filler 610 will be placed into first gap 612 of stringer 602. Radius filler kit 600 is positioned such that second section of radius filler 614 will be placed into second gap 616 of stringer 602.

Radius filler kit 600 further comprises ply 617. As depicted, ply 617 is positioned between plurality of segments of radius filler 609 and carrier material 618. After application of radius filler kit 600 to string 602, ply 617 forms an “inner mold line (IML) ply” of a resulting stiffener.

As depicted, radius filler kit 600 is being carried on carrier material 618. Carrier material 618 is formed of any desirable material. In some illustrative examples, carrier material 618 is a vacuum bag material. In some illustrative examples, carrier material 618 is a portion of a radius filler placement system, such as radius filler placement system 154 of FIG. 1.

Radius filler kit 600 is applied to stringer 602 by lowering carrier material 618 towards stringer 602. Radius filler kit 600 is lowered such that plurality of segments of radius filler 609 is applied to first gap 612 and second gap 616 of stringer 602. First gap 612 and second gap 616 are separated by distance 620. First section of radius filler 610 and second section of radius filler 614 on carrier material 618 are separated by distance 620 prior to application to stringer 602.

Plurality of segments of radius filler 609 is applied to first gap 612 and second gap 616 simultaneously. Radius filler kit 600, including first section of radius filler 610 and second section of radius filler 614, is lowered such that first section of radius filler 610 is applied to first gap 612 and second section of radius filler 614 is applied to second gap 616 simultaneously.

Carrier material 618 and radius filler kit 600 are lowered towards stiffener forming tool 605 to apply radius filler kit 600 to stringer 602. In some illustrative examples, carrier material 618 holding radius filler kit 600 may be transported in a substantially planar state. In other illustrative examples, carrier material 618 holding radius filler kit 600 may be transported in a rolled state. In some illustrative examples, applying plurality of segments of radius filler 609 comprises unrolling carrier material 618 and radius filler kit 600. In other illustrative examples, carrier material 618 and radius filler kit 600 are unrolled after transportation but prior to application of radius filler kit 600 to stringer 602.

After applying radius filler kit 600 to stringer 602, a compression force is applied to create a greater adhesive force between radius filler kit 600 and stringer 602 than between radius filler kit 600 and carrier material 618. When the adhesive force between radius filler kit 600 and stringer 602 is greater than the adhesive force between radius filler kit 600 and carrier material 618, carrier material 618 may be removed from radius filler kit 600. In some illustrative examples, carrier material 618 is pulled or peeled off of radius filler kit 600. In some illustrative examples, carrier material 618 is rolled onto a manifold to remove carrier material 618 from radius filler kit 600. In some illustrative examples, carrier material 618 is removed from radius filler kit 600 as a whole. When carrier material 618 is removed

from radius filler kit 600, first section of radius filler 610 remains in first gap 612 and second section of radius filler 614 remains in second gap 616.

In some illustrative examples, carrier material 618 is a vacuum bag material. When carrier material 618 is a vacuum bag material, the vacuum bag material may be sealed to stiffener forming tool 605 holding stringer 602 after applying radius filler kit 600 to stringer 602. In these illustrative examples, a vacuum may be applied to plurality of segments of radius filler 609 and stringer 602 to apply compression force to plurality of segments of radius filler 609. After applying the vacuum, carrier material 618 is removed.

In some illustrative examples, plurality of segments of radius filler 609 and stringer 602 may be cured prior to removing carrier material 618. In other illustrative examples, plurality of segments of radius filler 609 and stringer 602 are cured after removing carrier material 618. For example, plurality of segments of radius filler 609 and stringer 602 may be components of a larger composite layup. In this example, after positioning the other components of the larger composite layup, the composite layup is co-cured as a whole. For example, plurality of segments of radius filler 609 and stringer 602 may be components of a barrel section of an aircraft. In this illustrative example, the barrel section may be cured after a composite skin is placed over plurality of segments of radius filler 609 and stringer 602.

The illustration of radius filler kit 600, carrier material 618, and stiffener forming tool 605 in FIG. 6 is not meant to imply physical or architectural limitations to the manner in which an illustrative embodiment may be implemented. Other components in addition to or in place of the ones illustrated may be used. Some components may be unnecessary. Also, the blocks are presented to illustrate some functional components. One or more of these blocks may be combined, divided, or combined and divided into different blocks when implemented in an illustrative embodiment.

Channel 604 may be a portion of a stiffener forming tool having any desirable size, shape, or quantity of channels. Channel 604 may have any desirable size or shape. Radius filler kit 600 is depicted as having two radius filler sections. In other illustrative examples, radius filler kit 600 may have greater than two radius filler sections.

As another example, first section of radius filler 610 and second section of radius filler 614 have domed cross-sectional shape 622. In other non-depicted illustrative examples, first section of radius filler 610 and second section of radius filler 614 may have other desirable shapes. For example, first section of radius filler 610 and second section of radius filler 614 may have a triangular cross-sectional shape.

Radius filler kit 600 may be positioned and applied to stringer 604 in any desirable fashion such as manually, in an automated fashion, or some combination of the two. For example, carrier material 618 may be maneuvered manually or using automated equipment. In some illustrative examples, a compression force is applied to radius filler kit 600 manually. In some illustrative examples, a compression force is applied to radius filler kit 600 in an automated fashion.

Turning now to FIG. 7, an illustration of an isometric view of a radius filler placement system having a manifold is depicted in accordance with an illustrative embodiment. Radius filler placement system 700 is a physical implementation of radius filler placement system 154 of FIG. 1. In some illustrative examples, carrier material 418 of FIG. 4 is a component of radius filler placement system 700 of FIG.

7. In some illustrative examples, carrier material **618** of FIG. **6** is a component of radius filler placement system **700** of FIG. **7**.

Radius filler placement system **700** has roller manifold **702** and carrier material **704**. Carrier material **704** is bonded to roller manifold **702**. Vacuum is supplied to a vacuum chamber (not depicted) of roller manifold **702** through vacuum supply **706** connected to first end **708** of roller manifold **702**. Second end **710** of roller manifold **702** is sealed to create the vacuum chamber (not depicted) inside roller manifold **702**.

Carrier material **704** may be used to lift a radius filler kit from a radius filler forming tool, such as lifting radius filler kit **100** from radius filler forming tool **112** of FIG. **1**. Carrier material **704** may be used to lift a radius filler kit from at least one of radius filler forming tool **200** of FIG. **2** or radius filler forming tool **500** of FIG. **5**.

To lift a radius filler kit, a vacuum is pulled between carrier material **704** and a radius filler forming tool. After lifting the radius filler kit, the radius filler kit and carrier material **704** may be wrapped in a roll around roller manifold **702**. A radius filler kit may be transported in a rolled state on radius filler placement system **700**.

Carrier material **704** may also be used as a backing paper and a compaction bag when applying a radius filler kit to a stringer. To apply a radius filler kit to a stringer, carrier material **704** and the radius filler kit are unrolled from roller manifold **702**. Afterwards, a vacuum is pulled beneath carrier material **704** to compact the radius filler kit and remove the radius filler kit from carrier material **704**.

Radius filler placement system **700** may reduce at least one of manufacturing time or manufacturing cost. Radius filler placement system **700** is reusable. Further, radius filler placement system **700** may replace disposable manufacturing materials. For example, radius filler placement system **700** may replace disposable vacuum bagging materials. Radius filler placement system **700** may reduce manufacturing waste.

Radius filler placement system **700** may be operated in any desirable manner. Radius filler placement system **700** may be placed and operated manually, in an automated fashion, or some combination of the two. In some illustrative examples, radius filler placement system **700** is positioned manually. In other illustrative examples, radius filler placement system **700** is positioned using an automated system. In some illustrative examples, radius filler placement system **700** is rolled manually. In other illustrative examples, radius filler placement system **700** is rolled in a completely or partially automated fashion.

Turning now to FIG. **8**, an illustration of a cross-sectional view of a radius filler placement system having a manifold is depicted in accordance with an illustrative embodiment. View **800** is a cross-sectional view of radius filler placement system **700** of FIG. **7**.

Radius filler placement system **700** has roller manifold **702** having vacuum opening **801**. Carrier material **704** takes the form of vacuum bag material **802**. Vacuum bag material **802** is connected to roller manifold **702**. Vacuum bag material **802** has opening **803** interfacing with vacuum opening **801**.

As depicted in view **800**, carrier material **704** comprises multiple layers. As depicted, carrier material **704** is formed from first layer **804** and second layer **806**. First layer **804** is formed of a vacuum bagging material. In some illustrative examples, first layer **804** is formed of a latex material. In some illustrative examples, first layer **804** may be referred to as a first latex sheet.

Vacuum bag material **802** is configured to lift a composite material. The composite material may take any desirable form. In some illustrative examples, the composite material includes a ply, such as ply **108** of FIG. **1**. In some illustrative examples, the composite material includes the composite material includes plurality of segments of radius filler **132** of FIG. **1**. In some illustrative examples, the composite material includes radius filler kit **100** of FIG. **1**.

First layer **804** has first surface **808** and second surface **810**. First surface **808** is configured to have a tackiness desirable to form a vacuum seal between first surface **808** and tooling. Second surface **810** is configured to be substantially non-adhesive. For example, second surface **810** is configured to prevent second surface **810** from sticking to roller manifold **702**. As another example, second surface **810** is configured to prevent second surface **810** from sticking to a composite material of a radius filler kit.

Second layer **806** is formed of a vacuum bagging material. In some illustrative examples, second layer **806** is formed of a latex material. In some illustrative examples, second layer **806** may be referred to as a second latex sheet.

Although not depicted, second layer **806** is bonded to first layer **804**. The second latex sheet is bonded to the first latex sheet in any desirable fashion. In some illustrative examples, one of epoxy, mechanical fasteners, or welding connects first layer **804** and second layer **806** in selected locations.

Second layer **806** has first surface **812** and second surface **814**. First surface **812** is configured to have a tackiness desirable to adhere to a composite material of a radius filler kit. First surface **812** has a tackiness desirable to act as a carrier for the radius filler kit.

Second surface **814** is configured to be substantially non-adhesive. For example, second surface **814** is configured to prevent second surface **814** from sticking to first surface **808** of first layer **804**. As another example, second surface **810** is configured to allow for distribution of vacuum between first layer **804** and second layer **806**.

Breather **816** is positioned between first layer **804** and second layer **806**. Breather **816** distributes vacuum to the edge of first layer **804**. Breather **816** is in vacuum communication with vacuum opening **801**.

In some illustrative examples, when first layer **804** and second layer **806** are a first latex sheet and a second latex sheet, each have a respective mesh surface. In some illustrative examples, second surface **810** of first layer **804** is a mesh surface. In some illustrative examples, second surface **814** of second layer **806** is a mesh surface.

As depicted, roller manifold **702** has machined surface **818**. As depicted, vacuum bag material **802** is connected to machined surface **818**. Machined surface **818** may ease positioning of vacuum opening **801** relative to a tool. As depicted, vacuum opening **801** is positioned within machined surface **818**.

The illustrations of radius filler placement system **700** in FIGS. **7** and **8** are not meant to imply physical or architectural limitations to the manner in which an illustrative embodiment may be implemented. Other components in addition to or in place of the ones illustrated may be used. Some components may be unnecessary. Also, the blocks are presented to illustrate some functional components. One or more of these blocks may be combined, divided, or combined and divided into different blocks when implemented in an illustrative embodiment.

Although not depicted, in some illustrative examples, radius filler placement system **700** may include at least one heating element. For example, vacuum bag material **802**

may have integrated heating elements. As another example, roller manifold **702** may have a heating element.

Turning now to FIG. **9**, an illustration of a radius filler placement system having a roller manifold sealed to a radius filler forming tool is depicted in accordance with an illustrative embodiment. In view **900**, radius filler placement system **700** of FIGS. **7** and **8** is sealed to radius filler forming tool **902**. In view **900**, first layer **804** is transparent to more easily view radius filler forming tool **902**. Radius filler forming tool **902** is a physical implementation of radius filler forming tool **112** of FIG. **1**. In some illustrative examples, radius filler forming tool **902** may be radius filler forming tool **200** of FIG. **2** or radius filler forming tool **500** of FIG. **5**.

As depicted, first layer **804** of carrier material **704** is sealed to vacuum channel **904** of radius filler forming tool **902**. Second layer **806** extends across radius filler kit **906**. In view **900**, first layer **804** is transparent to more easily view second layer **806**. As depicted, radius filler kit **906** has first section of radius filler **908**, second section of radius filler **910**, and ply **912**. Each of first section of radius filler **908**, second section of radius filler **910**, and ply **912** are present between radius filler forming tool **902** and second layer **806**. Each of first section of radius filler **908**, second section of radius filler **910**, and ply **912** are shown in dashed lines to depict placement below second layer **806**.

After releasing vacuum from beneath carrier material **704**, radius filler kit **906** is carried by second layer **806**. In some illustrative examples, after releasing vacuum from beneath carrier material **704**, radius filler kit **906** and carrier material **704** are rolled onto roller manifold **702**.

Radius filler placement system **700** may be operated to lift radius filler kit **906** in any desirable manner. Radius filler placement system **700** may be placed and operated manually, in an automated fashion, or some combination of the two. In some illustrative examples, radius filler placement system **700** is positioned relative to radius filler kit **906** and radius filler forming tool **902** manually. In other illustrative examples, radius filler placement system **700** is positioned relative to radius filler kit **906** and radius filler forming tool **902** using an automated system. Radius filler placement system **700** may apply a compressive force using vacuum based on operator supplied or system supplied commands.

After applying a compression force, radius filler placement system **700** is used to lift radius filler kit **906** from radius filler forming tool **902**. In some illustrative examples, radius filler placement system **700** is removed from radius filler forming tool **902** manually. In other illustrative examples, radius filler placement system **700** is removed from radius filler forming tool **902** using completely or partially automated equipment.

In some illustrative examples, after applying a compression force, radius filler placement system **700** is rolled. In some illustrative examples, radius filler placement system **700** holding radius filler kit **906** is rolled manually. In other illustrative examples, radius filler placement system **700** holding radius filler kit **906** is rolled in a completely or partially automated fashion.

Turning now to FIG. **10**, an illustration of a radius filler placement system having a manifold sealed to a stiffener forming tool having a stringer is depicted in accordance with an illustrative embodiment. In view **1000**, radius filler placement system **700** of FIGS. **7** and **8** is sealed to bladder **1002** and stiffener forming tool **1004**. More specifically, first layer **804** of carrier material **704** is sealed to bladder **1002**

and stiffener forming tool **1004**. In view **1000**, first layer **804** is transparent for ease of viewing stringer **1006** and bladder **1002**.

More specifically, radius filler placement system **700** is sealed around stringer **1006** to receive radius filler kit **906** of FIG. **9**. Stringer **1006** is positioned on stiffener forming tool **1004**.

By applying vacuum beneath carrier material **704**, radius filler kit **906** is pressed against stringer **1006**. After releasing the vacuum from beneath carrier material **704**, radius filler placement system **700** is removed from stiffener forming tool **1004**. After removing radius filler placement system **700**, radius filler kit **906** remains on stringer **1006**.

In view **1000**, a cutaway is present to depict the positioning of second layer **806** of carrier material **704** and radius filler kit **906** relative to stringer **1006**. This cut-away view is present only for illustrative purposes of the positioning of second layer **806** and radius filler kit **906** and is not intended to imply limits as to the length of carrier material **704** and radius filler kit **906**. For example, although a cut-away is depicted, radius filler kit **906** may extend to the edge of stringer **1006**.

Radius filler placement system **700** may be operated to position and apply radius filler kit **906** in any desirable manner. Radius filler placement system **700** may be placed and operated manually, in an automated fashion, or some combination of the two. In some illustrative examples, radius filler placement system **700** is positioned relative to stringer **1006** manually. In other illustrative examples, radius filler placement system **700** is positioned relative to stringer **1006** using an automated system. Radius filler placement system **700** may apply a compressive force using vacuum based on operator supplied or system supplied commands.

After applying a compression force, radius filler placement system **700** is removed from radius filler kit **906** and stringer **1006**. In some illustrative examples, radius filler placement system **700** is removed from radius filler kit **906** and stringer **1006** manually. In other illustrative examples, radius filler placement system **700** is removed from radius filler kit **906** and stringer **1006** using completely or partially automated equipment.

The different components shown in FIGS. **2-10** may be combined with components in FIG. **1**, used with components in FIG. **1**, or a combination of the two. Additionally, some of the components in FIGS. **2-10** may be illustrative examples of how components shown in block form in FIG. **1** can be implemented as physical structures.

Turning now to FIGS. **11A** and **11B**, illustrations of flowcharts of a method for applying more than one segment of a radius filler to a stringer is depicted in accordance with an illustrative embodiment. Method **1100** may be implemented to form and apply radius filler kit **100** of FIG. **1**. Method **1100** may be implemented using radius filler forming tool **112** and radius filler placement equipment **144** of FIG. **1**. Method **1100** may be implemented using radius filler forming tool **200** of FIG. **2**. Method **1100** may be implemented to apply a plurality of segments of radius filler to a stringer, on a stiffener forming tool, such as stiffener forming tool **300** of FIGS. **3** and **4**. Method **1100** may be implemented using radius filler forming tool **500** of FIG. **5**. Method **1100** may be implemented using a radius filler placement system having a roller manifold such as radius filler placement system **700** of FIGS. **7-10**.

Method **1100** positions a plurality of segments of radius filler onto a radius filler forming tool (operation **1102**). Method **1100** applies the plurality of segments of radius

filler to a stringer in a single placement step (operation **1104**). Afterwards, the method terminates.

In some illustrative examples, positioning the plurality of segments of radius filler comprises forming joints using the plurality of segments of radius filler (operation **1106**). In some illustrative examples, positioning the plurality of segments of radius filler comprises forming a plurality of butt joints. In some illustrative examples, by forming joints, the plurality of segments of radius filler are formed into a smaller quantity of sections of radius filler, each section having a greater length than the provided length of the plurality of segments of radius filler. In one illustrative example, the plurality of segments of radius filler may have a manufactured length in the range of four feet to six feet. In this illustrative example, the plurality of segments of radius filler are joined to form at least one section of radius filler that is greater than the manufactured length of the plurality of segments of radius filler. For example, the at least one section of radius filler may be 10 feet long, 20 feet long, 25 feet long, or any other desirable length.

In some illustrative examples of method **1100**, the plurality of segments of radius filler are joined to form more than one section of radius filler. In some illustrative examples, the resulting sections of radius filler are each greater than the manufactured length of the plurality of segments of radius filler. In some illustrative examples, the resulting sections of radius filler are all the same length.

In some illustrative examples of method **1100**, positioning the plurality of segments of radius filler comprises placing the plurality of segments of radius filler into two grooves in the radius filler forming tool, wherein the two grooves are separated by a distance (operation **1108**). By positioning the plurality of segments of radius filler into two grooves in the radius filler forming tool, at least two sections of radius filler are formed. By positioning the plurality of segments of radius filler into two grooves in the radius filler forming tool, a first section of radius filler and a second section of radius filler are created separated by the distance.

In some illustrative examples of method **1100**, applying the plurality of segments of radius filler to the stringer comprises applying the plurality of segments to a first gap and a second gap of the stringer, wherein the first gap and the second gap are separated by the distance (operation **1110**). In some illustrative examples of method **1100**, applying the plurality of segments of radius filler to the first gap and the second gap comprises the plurality of segments of radius filler to the first gap and the second gap simultaneously (operation **1112**).

In some illustrative examples, the plurality of segments of radius filler are applied to the stringer using the radius filler forming tool. In some illustrative examples of method **1100**, applying the plurality of segments of radius filler comprises bending the radius filler forming tool to press the plurality of segments against the stringer and remove the plurality of segments of radius filler from the radius filler forming tool (operation **1114**). In some illustrative examples, method **1100** further comprises co-curing the plurality of segments of radius filler and the stringer to form a portion of an aircraft (operation **1115**).

In other illustrative examples, radius filler placement equipment other than the radius filler forming tool is used to apply the plurality of segments of radius filler to the stringer. In some illustrative examples, method **1100** lifts the plurality of segments of radius filler from the radius filler forming tool using a carrier material, wherein applying the plurality of segments of radius filler is performed using the carrier

material (operation **1116**). The carrier material takes the form of any desirable type of material.

In some illustrative examples, the carrier material is a vacuum bag material, and method **1100** seals the vacuum bag material to a stiffener forming tool holding the stringer (operation **1118**). In some illustrative examples, method **1100** also applies a vacuum to the plurality of segments of radius filler and the stringer to apply compression force to the plurality of segments of radius filler (operation **1120**). The compression force applied is sufficient to create an adhesion between the plurality of segments of radius filler and the stringer that is greater than the adhesion between the plurality of segments of radius filler and the vacuum bag material. After applying the vacuum to apply the compression force, the vacuum bag may be removed from the stringer, leaving the plurality of segments of radius filler in contact with the stringer.

In some illustrative examples, the vacuum bag material is a component of a radius filler placement system, and method **1100** rolls the plurality of segments of radius filler and the carrier material around a manifold of a radius filler placement system (operation **1122**). In some illustrative examples, applying the plurality of segments of radius filler to the stringer comprises unrolling the plurality of segments of radius filler from the roller manifold (operation **1124**).

Turning now to FIG. **12**, an illustration of a flowchart of a method for using a radius filler kit is depicted in accordance with an illustrative embodiment. Method **1200** may be implemented to position and apply radius filler kit **100** of FIG. **1**. Method **1200** may be implemented using radius filler placement equipment **144** of FIG. **1**. Method **1200** may be implemented to apply a plurality of segments of radius filler to a stringer, on a stiffener forming tool, such as stiffener forming tool **300** of FIGS. **3** and **4**. Method **1200** may be implemented using a radius filler placement system having a roller manifold such as radius filler placement system **700** of FIGS. **7-10**.

Method **1200** positions a radius filler kit relative to a stringer (operation **1202**). Method **1200** applies the radius filler kit to the stringer in a single placement step (operation **1204**). Afterwards, the method terminates.

In some illustrative examples, the radius filler kit is transported in a rolled state. For example, the radius filler kit may be rolled on a carrier material for at least one of transportation or storage purposes. In these illustrative examples, applying the radius filler kit to the stringer comprises unrolling the radius filler kit to contact the stringer (operation **1206**).

In some illustrative examples, applying the radius filler kit to the stringer comprises placing a first section of a radius filler of the radius filler kit into a first gap of the stringer and a second section of the radius filler of the radius filler kit into a second gap of the stringer (operation **1208**). Further, in some of these illustrative examples, applying the radius filler kit to the stringer places the first section of the radius filler and the second section of the radius filler simultaneously (operation **1210**).

In some illustrative examples, the radius filler kit is transported using a radius filler forming tool. In some of these illustrative examples, the radius filler kit may be applied to the stringer using the radius filler forming tool. In one illustrative example, applying the radius filler kit to the stringer comprises bending a radius filler forming tool to press the plurality of segments against the stringer and remove the plurality of segments of radius filler from the radius filler forming tool (operation **1212**).

In some illustrative examples of method **1200**, applying the radius filler kit comprises simultaneously applying a first section of radius filler, a second section of radius filler, and a ply to a stringer (operation **1214**). By simultaneously applying the first section of the radius filler, the second section of the radius filler, and the ply to the stringer, the application time to the stringer is reduced.

In some illustrative examples, method **1200** applies a compression force to the radius filler kit (operation **1216**). By applying a compression force to the radius filler kit, the radius filler kit is transferred to the stringer.

In some illustrative examples, method **1200** seals a vacuum bag material to a stiffener forming tool holding the stringer (operation **1218**). In some illustrative examples, method **1200** then applies a vacuum to the stringer and radius filler kit below the vacuum bag material (operation **1220**). In some illustrative examples, the vacuum applies a compaction force to the radius filler kit. In some illustrative examples, by applying a vacuum to the stringer and the radius filler kit, the radius filler kit is transferred from the vacuum bag material to the stringer.

In some illustrative examples, method **1200** co-cures the radius filler kit and the stringer to form a portion of an aircraft (operation **1222**). The radius filler kit and the stringer may comprise any desirable portion of an aircraft that has a composite stiffener.

Turning now to FIG. **13**, an illustration of a flowchart of a method for forming a radius filler kit is depicted in accordance with an illustrative embodiment. Method **1300** may be implemented using radius filler forming tool **112** of FIG. **1**. Method **1300** may be implemented using radius filler forming tool **200** of FIG. **2**. Method **1300** may be implemented using radius filler forming tool **500** of FIG. **5**. Method **1300** may result in radius filler kit **600** of FIG. **6**.

Method **1300** positions a plurality of segments of radius filler onto a radius filler forming tool (operation **1302**). Method **1300** applies a ply over the plurality of segments of radius filler (operation **1304**). Method **1300** applies a compression force to the plurality of segments of radius filler and the ply to form a radius filler kit (operation **1306**). Afterwards, the method terminates.

In some illustrative examples, positioning the plurality of segments of radius filler comprises forming joints using the plurality of segments of radius filler (operation **1308**). In some illustrative examples, positioning the plurality of segments of radius filler comprises forming a plurality of butt joints. In some illustrative examples, by forming joints, the plurality of segments of radius filler is formed into a smaller quantity of sections of radius filler, each section having a greater length than the provided length of the plurality of segments of radius filler. In one illustrative example, the plurality of segments of radius filler may have a manufactured length in the range of four feet to six feet. In this illustrative example, the plurality of segments of radius filler is joined to form at least one section of radius filler that is greater than the manufactured length of the plurality of segments of radius filler. For example, the at least one section of radius filler may be 10 feet long, 20 feet long, 25 feet long, or any other desirable length.

In some illustrative examples of method **1100**, the plurality of segments of radius filler is joined to form more than one section of radius filler. In some illustrative examples, the resulting sections of radius filler are each greater than the manufactured length of the plurality of segments of radius filler. In some illustrative examples, the resulting sections of radius filler are all the same length.

In some illustrative examples, positioning the plurality of segments of radius filler comprises placing the plurality of segments of radius filler into two grooves in the radius filler forming tool, wherein the two grooves are separated by a distance (operation **1310**).

In some illustrative examples, placing the plurality of segments of radius filler into the two grooves forms a first section of radius filler and a second section of radius filler (operation **1312**). In some illustrative examples, method **1300** also coils the radius filler kit and a carrier material into a roll, wherein the first section of radius filler and a second section of radius filler are separated by the distance (operation **1314**).

In some illustrative examples, method **1300** shapes the plurality of segments of radius filler using a number of grooves of the radius filler forming tool (operation **1316**). The number of grooves of the radius filler forming tool may impart any desirable shape to plurality of segments of radius filler. In some illustrative examples, the number of grooves are configured to shape the plurality of segments of radius filler to a domed cross-sectional shape. In some illustrative examples, the number of grooves are configured to shape the plurality of segments of radius filler to a triangular cross-sectional shape.

After forming the radius filler kit, the radius filler kit will be transported for application to a stringer. In some illustrative examples, the radius filler kit will be stored prior to application to a stringer. In some illustrative examples, the radius filler kit is at least one of transported or stored on the radius filler forming tool.

In other illustrative examples, method **1300** removes the radius filler kit from the radius filler forming tool using a carrier material (operation **1318**). In some illustrative examples, method **1300** coils the radius filler kit and the carrier material into a roll (operation **1320**).

In some illustrative examples, the carrier material is a component of a radius filler placement system. In these illustrative examples, coiling the radius filler kit and the carrier material into a roll comprises rolling the radius filler kit and the carrier material around a manifold of a radius filler placement system (operation **1322**).

In some illustrative examples, method **1300** applies the radius filler kit to a stringer (operation **1324**). In some illustrative examples, method **1300** also co-cures the radius filler kit and the stringer (operation **1326**).

The flowcharts and block diagrams in the different depicted embodiments illustrate the architecture, functionality, and operation of some possible implementations of apparatus and methods in an illustrative embodiment. In this regard, each block in the flowcharts or block diagrams may represent a module, a segment, a function, and/or a portion of an operation or step.

In some alternative implementations of an illustrative embodiment, the function or functions noted in the blocks may occur out of the order noted in the figures. For example, in some cases, two blocks shown in succession may be executed substantially concurrently, or the blocks may sometimes be performed in the reverse order, depending upon the functionality involved. Also, other blocks may be added, in addition to the illustrated blocks, in a flowchart or block diagram.

In some illustrative examples, not all blocks of method **1100**, method **1200**, or method **1300** are performed. For example, each of operations **1116-1124** in FIG. **11B** may be optional operations of method **1100**. Additionally, operations **1106** and **1114** may be optional operations of method **1100**. As another example, each of operations **1206-1220**

may be optional operations of method **1200**. More specifically, operations **1206** and operation **1212** may be alternative operations. As yet another example, each of operations **1308-1322** may be optional.

Illustrative embodiments of the present disclosure may be described in the context of aircraft manufacturing and service method **1400** as shown in FIG. **14** and aircraft **1500** as shown in FIG. **15**. Turning first to FIG. **14**, an illustration of an aircraft manufacturing and service method is depicted in accordance with an illustrative embodiment. During pre-production, aircraft manufacturing and service method **1400** may include specification and design **1402** of aircraft **1500** in FIG. **15** and material procurement **1404**.

During production, component and subassembly manufacturing **1406** and system integration **1408** of aircraft **1500** takes place. Thereafter, aircraft **1500** may go through certification and delivery **1410** in order to be placed in service **1412**. While in service **1412** by a customer, aircraft **1500** is scheduled for routine maintenance and service **1414**, which may include modification, reconfiguration, refurbishment, and other maintenance or service.

Each of the processes of aircraft manufacturing and service method **1400** may be performed or carried out by a system integrator, a third party, and/or an operator. In these examples, the operator may be a customer. For the purposes of this description, a system integrator may include, without limitation, any number of aircraft manufacturers or major-system subcontractors; a third party may include, without limitation, any number of vendors, subcontractors, or suppliers; and an operator may be an airline, a leasing company, a military entity, a service organization, and so on.

With reference now to FIG. **15**, an illustration of an aircraft is depicted in which an illustrative embodiment may be implemented. In this example, aircraft **1500** is produced by aircraft manufacturing and service method **1400** in FIG. **14** and may include airframe **1502** with a plurality of systems **1504** and interior **1506**. Examples of systems **1504** include one or more of propulsion system **1508**, electrical system **1510**, hydraulic system **1512**, and environmental system **1514**. Any number of other systems may be included. Although an aerospace example is shown, different illustrative embodiments may be applied to other industries, such as the automotive industry.

Apparatuses and methods embodied herein may be employed during at least one of the stages of aircraft manufacturing and service method **1400**. One or more illustrative embodiments may be used during component and subassembly manufacturing **1406**, system integration **1408**, or maintenance and surface **1414** of FIG. **14**. For example, radius filler kit **100** of FIG. **1** may be used to fill radiuses of composite layups during component and subassembly manufacturing **1406**. As another example, radius filler kit **100** of FIG. **1** may be used to fill radiuses of composite layups of replacement parts during maintenance and surface **1414** of FIG. **14**. Additionally, radius filler placement system **154** of FIG. **1** may be used to place composite material, such as radius fillers, during one of component and subassembly manufacturing **1406** or maintenance and surface **1414** of FIG. **14**.

Apparatuses and methods embodied herein may be employed in manufacturing at least one component of aircraft **1500**. For example, radius filler kit **100** of FIG. **1** may be used to manufacture at least one of airframe **1502** or interior **1506**. Further, radius filler placement system **154** of FIG. **1** may be used to place composite material, such as radius fillers or other desirable composite material, to manufacture at least one of airframe **1502** or interior **1506**.

The illustrative examples provide methods and apparatuses to form and apply radius filler kits. By applying radius filler kits, stringer assembly work is developed into a feeder line activity. The application of radius filler kits enables new forming methods for at least one of lower cost or higher rate fabrication.

The illustrative examples provide methods and apparatuses for alternatives to applying radius filler portions individually to a composite layup. The illustrative examples provide methods and apparatuses for applying multiple radius filler portions in a single application step.

The illustrative examples provide an off-line tool, the radius filler forming tool, which controls parallel spacing of the radius filler. In some illustrative examples, the radius filler forming tool shapes the radius filler (noodle). The illustrative examples offer the opportunity to pre-form the noodles to an approximate shape, assemble with an inner mold line fabric ply, transport to assembly, and then aid in installation into the assembly.

The illustrative examples reduce at least one of the quantity of compaction steps, radii buckling, or installation steps. For example, by compacting the ply onto the plurality of segments of radius filler on the radius filler forming tool, a quantity of compaction steps may be reduced. As another example, by pre-shaping the plurality of segments of radius filler, wrinkling or radii buckling may be reduced. The illustrative examples may result in reduced wrinkling due to a pre-formed noodle.

The illustrative examples provide the ability to pre-shape the noodles to a general shape and to kit the radius filler (noodles) with the IML (inner mold line) ply. In some illustrative examples, the radius filler kits are rolled into a spiral for storage. In some illustrative examples, latex material of a radius filler placement system enables rolling the radius filler kits into a spiral for storage. In some illustrative examples, by placing the radius filler (noodles) on the IML ply furnish, an indexing ability is provided relative to a bladder.

The illustrative examples provide a forming plate, the radius filler forming tool, to shape the radius filler (noodle). The illustrative examples allow for cold consolidation of the radius filler (noodle) to a prepreg ply. The illustrative examples provide a radius filler forming tool that pre-aligns the noodles to a desired parallel off-set. The illustrative examples provide a ready vacuum bag layer. The illustrative examples provide a radius filler placement system that has the ability to roll into a spiral for storage or carry, and will also work as an index feature.

One key process parameter to establish is the compaction force between plies and carrier material for adherence. The compaction force enables roll up and transfer, but is below a higher compaction force between prepreg and sub-assembly during final transfer.

In one illustrative example, the same material is used as a carrier, a roller, a backing paper, and a compaction bag. More specifically, the vacuum bag material of the radius filler placement system may be used as a carrier, a roller, a backing paper, and a compaction bag for a radius filler kit. The vacuum bag of the radius filler placement system may lift the radius filler kit from the radius filler forming tool, acting as a carrier. The vacuum bag of the radius filler placement system may then roll along with the radius filler kit, to act as a roller. The vacuum bag of the radius filler placement system may then be unrolled to position the radius filler kit relative to a stringer, acting as a backing

paper. The vacuum bag of the radius filler system may then apply a vacuum to the radius filler kit, acting as a compaction bag.

The illustrative examples may transfer and kit entire subassemblies. In some illustrative examples, the subassembly is an inner mold line ply and radii fillers kit. In another illustrative example, radii fillers may be transferred and kitted.

The illustrative examples may transfer a radius filler kit in a roll form. In some illustrative examples, the radius filler kit includes a ply and a plurality of sections of radius filler.

The description of the different illustrative embodiments has been presented for purposes of illustration and description, and is not intended to be exhaustive or limited to the embodiments in the form disclosed. Many modifications and variations will be apparent to those of ordinary skill in the art. Further, different illustrative embodiments may provide different features as compared to other illustrative embodiments. The embodiment or embodiments selected are chosen and described in order to best explain the principles of the embodiments, the practical application, and to enable others of ordinary skill in the art to understand the disclosure for various embodiments with various modifications as are suited to the particular use contemplated.

What is claimed is:

1. A method comprising:
 - positioning a plurality of segments of radius filler onto a radius filler forming tool; and
 - applying the plurality of segments of radius filler to a stringer in a single placement step;
 - wherein applying the plurality of segments of radius filler comprises bending the radius filler forming tool to press the plurality of segments of radius filler against the stringer and remove the plurality of segments of radius filler from the radius filler forming tool.
2. The method of claim 1 further comprising:
 - co-curing the plurality of segments of radius filler and the stringer to form a portion of an aircraft.
3. The method of claim 1 further comprising:
 - lifting the plurality of segments of radius filler from the radius filler forming tool using a carrier material, wherein applying the plurality of segments of radius filler is performed using the carrier material.
4. The method of claim 3, wherein the carrier material is a vacuum bag material, the method further comprising:
 - sealing the vacuum bag material to a stiffener forming tool holding the stringer; and
 - applying a vacuum to the plurality of segments of radius filler and the stringer to apply compression force to the plurality of segments of radius filler.
5. The method of claim 4, wherein the vacuum bag material is a component of a radius filler placement system, the method further comprising:
 - rolling the plurality of segments of radius filler and the carrier material around a roller manifold of a radius filler placement system.
6. The method of claim 5, wherein applying the plurality of segments of radius filler to the stringer comprises unrolling the plurality of segments of radius filler from the roller manifold.
7. The method of claim 1, wherein positioning the plurality of segments of radius filler comprises forming joints using the plurality of segments of radius filler.
8. The method of claim 1, wherein positioning the plurality of segments of radius filler comprises placing the

plurality of segments of radius filler into two grooves in the radius filler forming tool, wherein the two grooves are separated by a distance.

9. The method of claim 8, wherein applying the plurality of segments of radius filler to the stringer comprises applying the plurality of segments of radius filler to a first gap and a second gap of the stringer, wherein the first gap and the second gap are separated by the distance.

10. The method of claim 9, wherein applying the plurality of segments of radius filler to the first gap and the second gap comprises the plurality of segments of radius filler to the first gap and the second gap simultaneously.

11. A method comprising:

- positioning a radius filler kit relative to a stringer; and
- applying the radius filler kit to the stringer in a single placement step;
 - wherein applying the radius filler kit to the stringer comprises bending a radius filler forming tool to press a plurality of segments of radius filler of the radius filler kit against the stringer and remove the plurality of segments of radius filler from the radius filler forming tool.

12. The method of claim 11 further comprising:

- co-curing the radius filler kit and the stringer to form a portion of an aircraft.

13. The method of claim 11 further comprising:

- applying a compression force to the radius filler kit.

14. The method of claim 11 further comprising:

- sealing a vacuum bag material to a stiffener forming tool holding the stringer; and
- applying a vacuum to the stringer and radius filler kit below the vacuum bag material.

15. The method of claim 11, wherein applying the radius filler kit to the stringer comprises unrolling the radius filler kit to contact the stringer.

16. The method of claim 11, wherein applying the radius filler kit to the stringer comprises placing a first section of radius filler of the radius filler kit into a first gap of the stringer and a second section of radius filler of the radius filler kit into a second gap of the stringer.

17. The method of claim 16, wherein applying the radius filler kit to the stringer places the first section of radius filler and the second section of radius filler simultaneously.

18. The method of claim 11, wherein applying the radius filler kit comprises simultaneously applying a first section of radius filler, a second section of radius filler, and a ply to the stringer.

19. A method comprising:

- positioning a plurality of segments of radius filler onto a radius filler forming tool; and
- applying the plurality of segments of radius filler to a stringer in a single placement step;
 - wherein positioning the plurality of segments of radius filler comprises placing the plurality of segments of radius filler into two grooves in the radius filler forming tool, wherein the two grooves are separated by a distance.

20. The method of claim 19 further comprising:

- co-curing the plurality of segments of radius filler and the stringer to form a portion of an aircraft.

21. The method of claim 19, wherein applying the plurality of segments of radius filler comprises bending the radius filler forming tool to press the plurality of segments of radius filler against the stringer and remove the plurality of segments of radius filler from the radius filler forming tool.

27

22. The method of claim 19 further comprising:
lifting the plurality of segments of radius filler from the
radius filler forming tool using a carrier material,
wherein applying the plurality of segments of radius
filler is performed using the carrier material.

23. The method of claim 22, wherein the carrier material
is a vacuum bag material, the method further comprising:
sealing the vacuum bag material to a stiffener forming tool
holding the stringer; and
applying a vacuum to the plurality of segments of radius
filler and the stringer to apply compression force to the
plurality of segments of radius filler.

24. The method of claim 23, wherein the vacuum bag
material is a component of a radius filler placement system,
the method further comprising:

rolling the plurality of segments of radius filler and the
carrier material around a roller manifold of a radius
filler placement system.

25. The method of claim 24, wherein applying the plu-
rality of segments of radius filler to the stringer comprises
unrolling the plurality of segments of radius filler from the
roller manifold.

26. The method of claim 19, wherein positioning the
plurality of segments of radius filler comprises forming
joints using the plurality of segments of radius filler.

27. The method of claim 19, wherein applying the plu-
rality of segments of radius filler to the stringer comprises
applying the plurality of segments of radius filler to a first
gap and a second gap of the stringer, wherein the first gap
and the second gap are separated by the distance.

28. The method of claim 27, wherein applying the plu-
rality of segments of radius filler to the first gap and the
second gap comprises the plurality of segments of radius
filler to the first gap and the second gap simultaneously.

29. A method comprising:
positioning a plurality of segments of radius filler onto a
radius filler forming tool;

applying the plurality of segments of radius filler to a
stringer in a single placement step; and

lifting the plurality of segments of radius filler from the
radius filler forming tool using a carrier material,
wherein applying the plurality of segments of radius
filler is performed using the carrier material;

28

wherein the carrier material is a vacuum bag material, the
method further comprising:
sealing the vacuum bag material to a stiffener forming tool
holding the stringer; and

applying a vacuum to the plurality of segments of radius
filler and the stringer to apply compression force to the
plurality of segments of radius filler.

30. The method of claim 29 further comprising:
co-curing the plurality of segments of radius filler and the
stringer to form a portion of an aircraft.

31. The method of claim 29, wherein applying the plu-
rality of segments of radius filler comprises bending the
radius filler forming tool to press the plurality of segments
of radius filler against the stringer and remove the plurality
of segments of radius filler from the radius filler forming
tool.

32. The method of claim 29, wherein the vacuum bag
material is a component of a radius filler placement system,
the method further comprising:

rolling the plurality of segments of radius filler and the
carrier material around a roller manifold of a radius
filler placement system.

33. The method of claim 32, wherein applying the plu-
rality of segments of radius filler to the stringer comprises
unrolling the plurality of segments of radius filler from the
roller manifold.

34. The method of claim 29, wherein positioning the
plurality of segments of radius filler comprises forming
joints using the plurality of segments of radius filler.

35. The method of claim 29, wherein positioning the
plurality of segments of radius filler comprises placing the
plurality of segments of radius filler into two grooves in the
radius filler forming tool, wherein the two grooves are
separated by a distance.

36. The method of claim 35, wherein applying the plu-
rality of segments of radius filler to the stringer comprises
applying the plurality of segments of radius filler to a first
gap and a second gap of the stringer, wherein the first gap
and the second gap are separated by the distance.

37. The method of claim 36, wherein applying the plu-
rality of segments of radius filler to the first gap and the
second gap comprises the plurality of segments of radius
filler to the first gap and the second gap simultaneously.

* * * * *