



US010731378B1

(12) **United States Patent**
Crandall et al.

(10) **Patent No.:** **US 10,731,378 B1**
(45) **Date of Patent:** **Aug. 4, 2020**

(54) **FENCE BRACE SYSTEM**

(71) Applicants: **Fonda Crandall**, Reno, NV (US);
Joseph Crandall, Reno, NV (US)

(72) Inventors: **Fonda Crandall**, Reno, NV (US);
Joseph Crandall, Reno, NV (US)

(*) Notice: Subject to any disclaimer, the term of this patent is extended or adjusted under 35 U.S.C. 154(b) by 420 days.

(21) Appl. No.: **15/856,710**

(22) Filed: **Dec. 28, 2017**

Related U.S. Application Data

(62) Division of application No. 14/863,793, filed on Sep. 24, 2015, now Pat. No. 10,030,408.

(51) **Int. Cl.**
E04H 17/14 (2006.01)

(52) **U.S. Cl.**
CPC . **E04H 17/1413** (2013.01); **E04H 2017/1473** (2013.01); **E04H 2017/1482** (2013.01)

(58) **Field of Classification Search**
CPC **E04H 17/1413**; **E04H 17/1417**; **E04H 17/1421**; **E04H 17/1426**; **E04H 17/143**; **E04H 17/1434**; **E04H 2017/1447**; **E04H 2017/1452**; **E04H 2017/1473**
See application file for complete search history.

(56) **References Cited**

U.S. PATENT DOCUMENTS

949,394 A *	2/1910	Daly	E04B 1/2403
2,608,386 A *	8/1952	Hart	E04H 17/1434
			256/65.06
4,078,772 A *	3/1978	Carbone	E04H 17/1434
			256/24
4,526,348 A *	7/1985	Cammack	E04H 17/1413
			256/65.06
5,657,967 A *	8/1997	Patrick	B29B 17/0042
			256/19
6,290,214 B1 *	9/2001	DeSouza	E04H 17/1413
			256/55
2007/0034846 A1 *	2/2007	Ratanasiriwilai ...	E04H 17/1413
			256/65.01
2014/0264219 A1 *	9/2014	McCann	E04H 17/1421
			256/65.01

* cited by examiner

Primary Examiner — Michael P Ferguson

(57) **ABSTRACT**

The present invention comprises a brace adapted to secure a fence rail to a fence post. This brace may optionally be installed onto an existing fence. The present invention may also be installed on a new fence. The brace may be adapted to support fences with cylindrical fence posts or rectangular fence posts and rectangular fence rails. Optional embodiments include braces for fence corner pieces. The brace may further optionally be adapted to secure fences on a steep incline. The invention includes a first fence rail brace member adapted to connect to 2 or more sides of a first fence rail; the first fence rail brace member is fused to a first side of a fence post brace member, the fence post brace member being adapted to connect to 2 or more sides of the fence post.

2 Claims, 7 Drawing Sheets

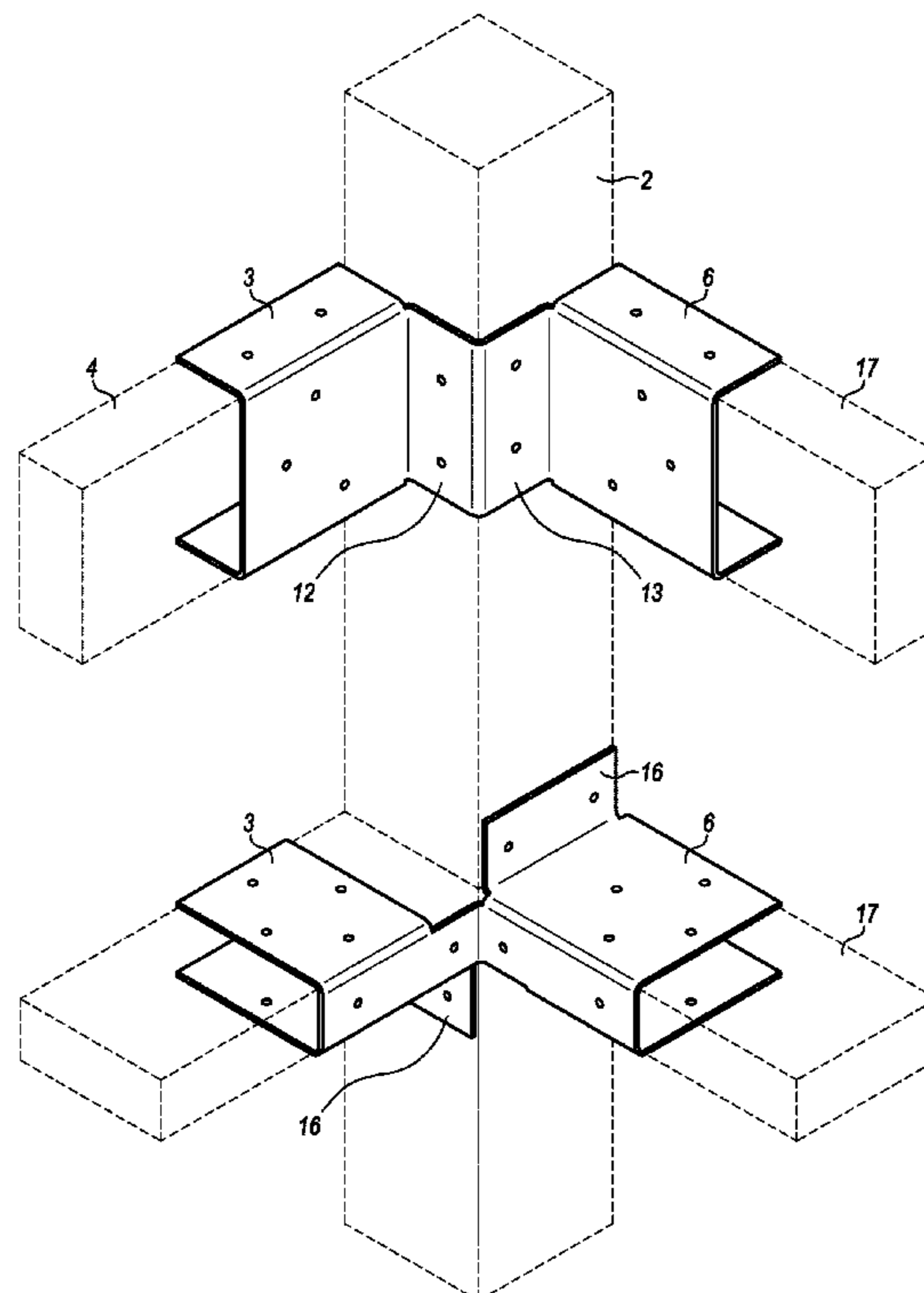

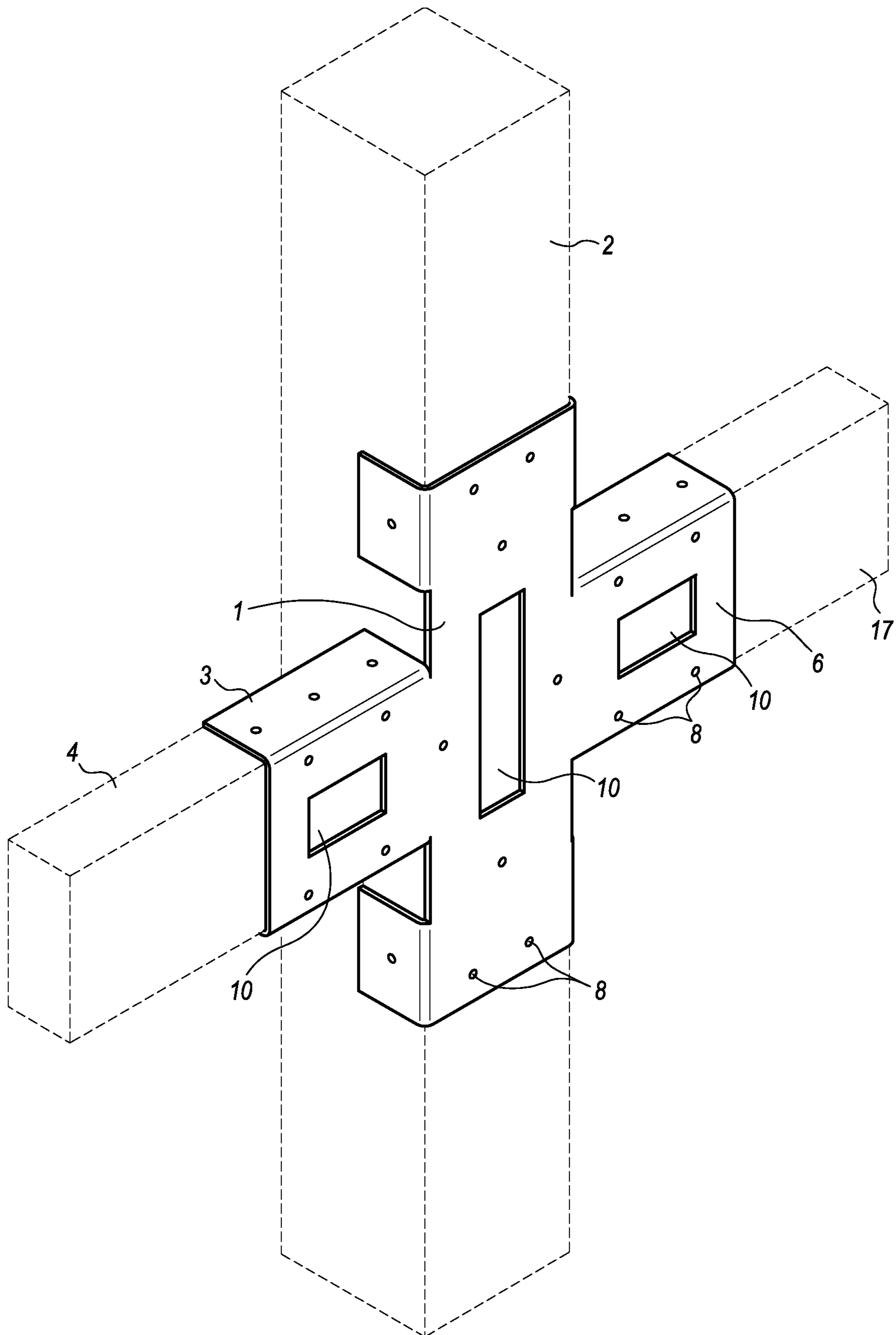

FIG. 1

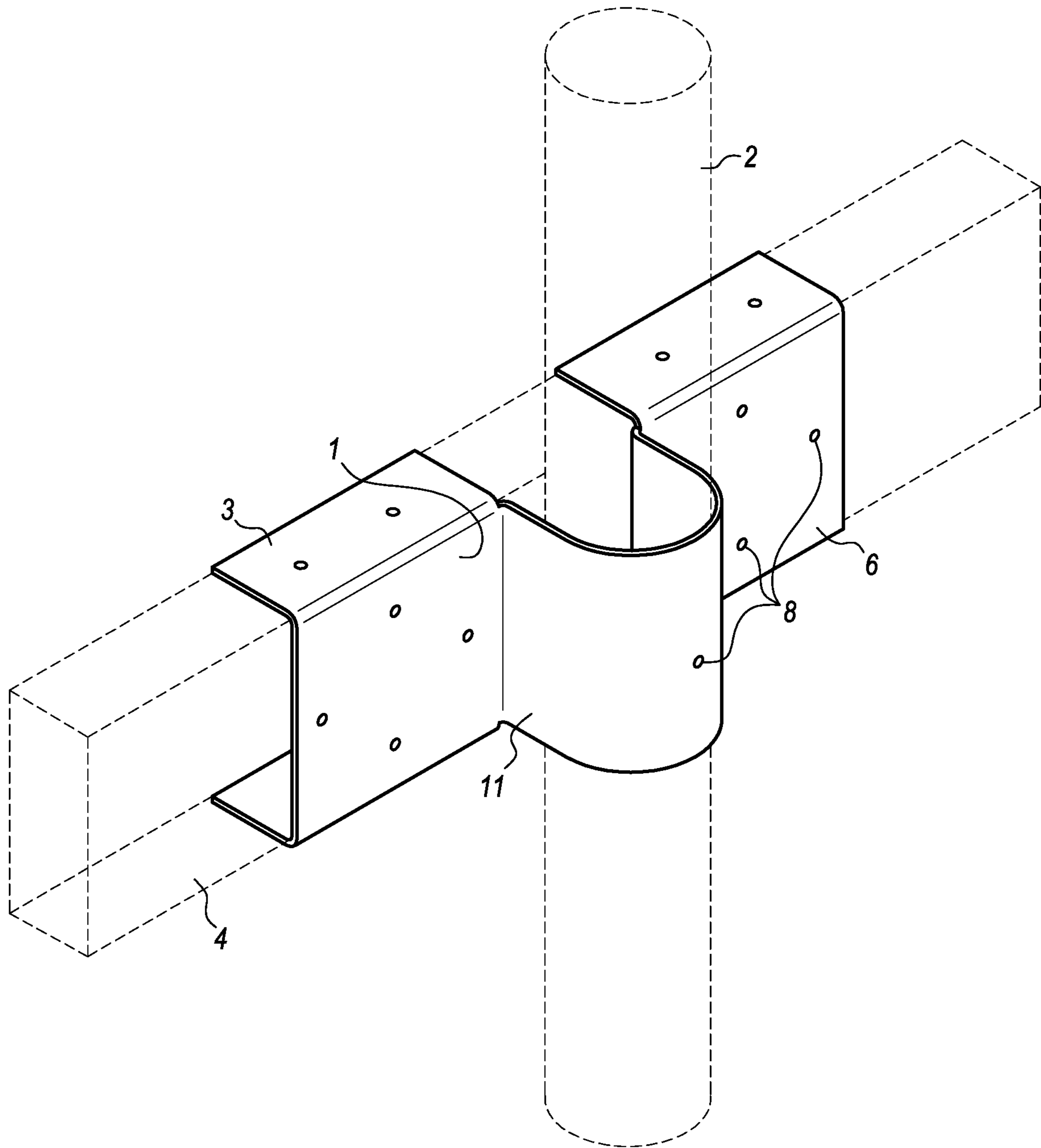

FIG. 2

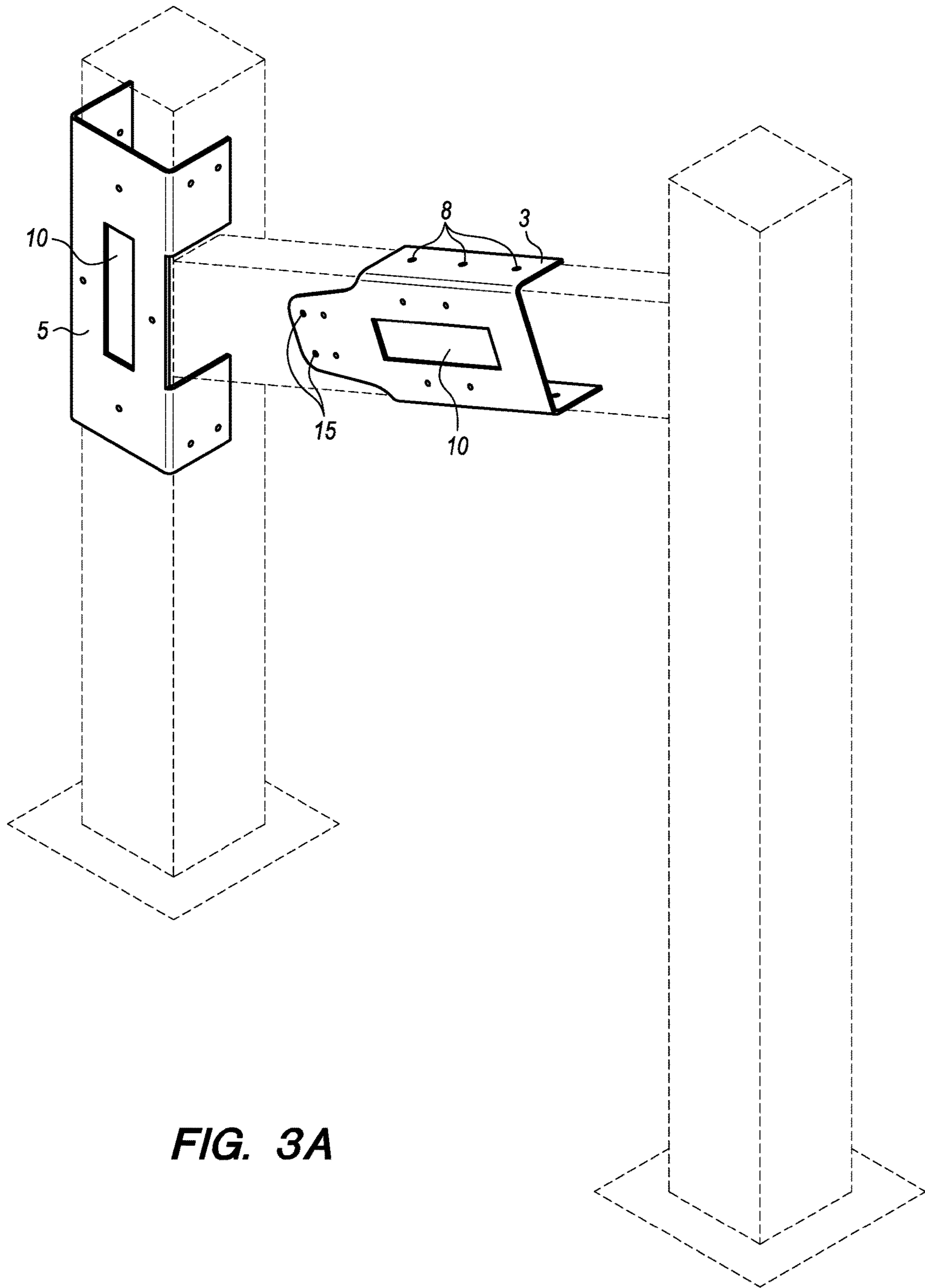

FIG. 3A

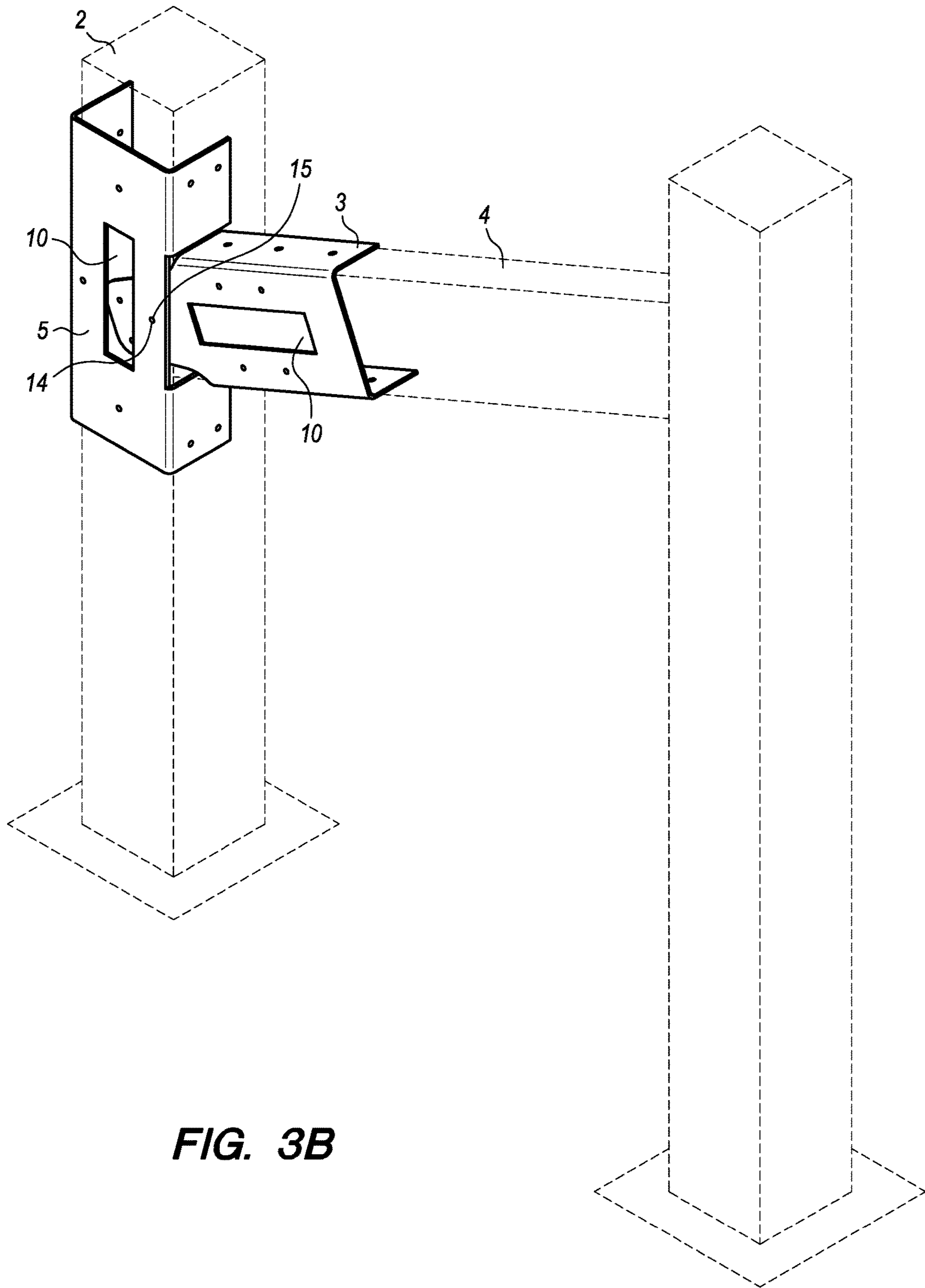

FIG. 3B

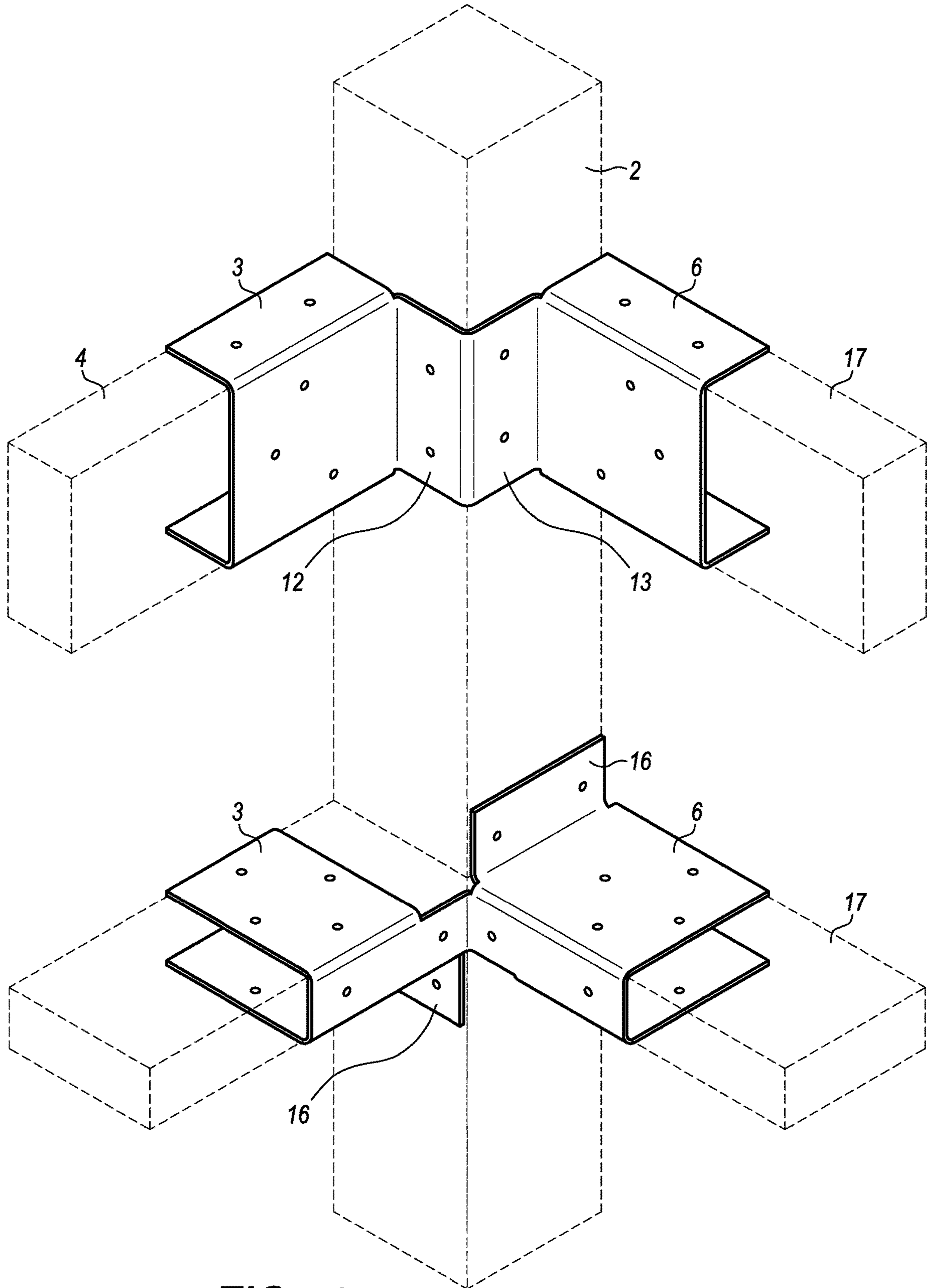

FIG. 4

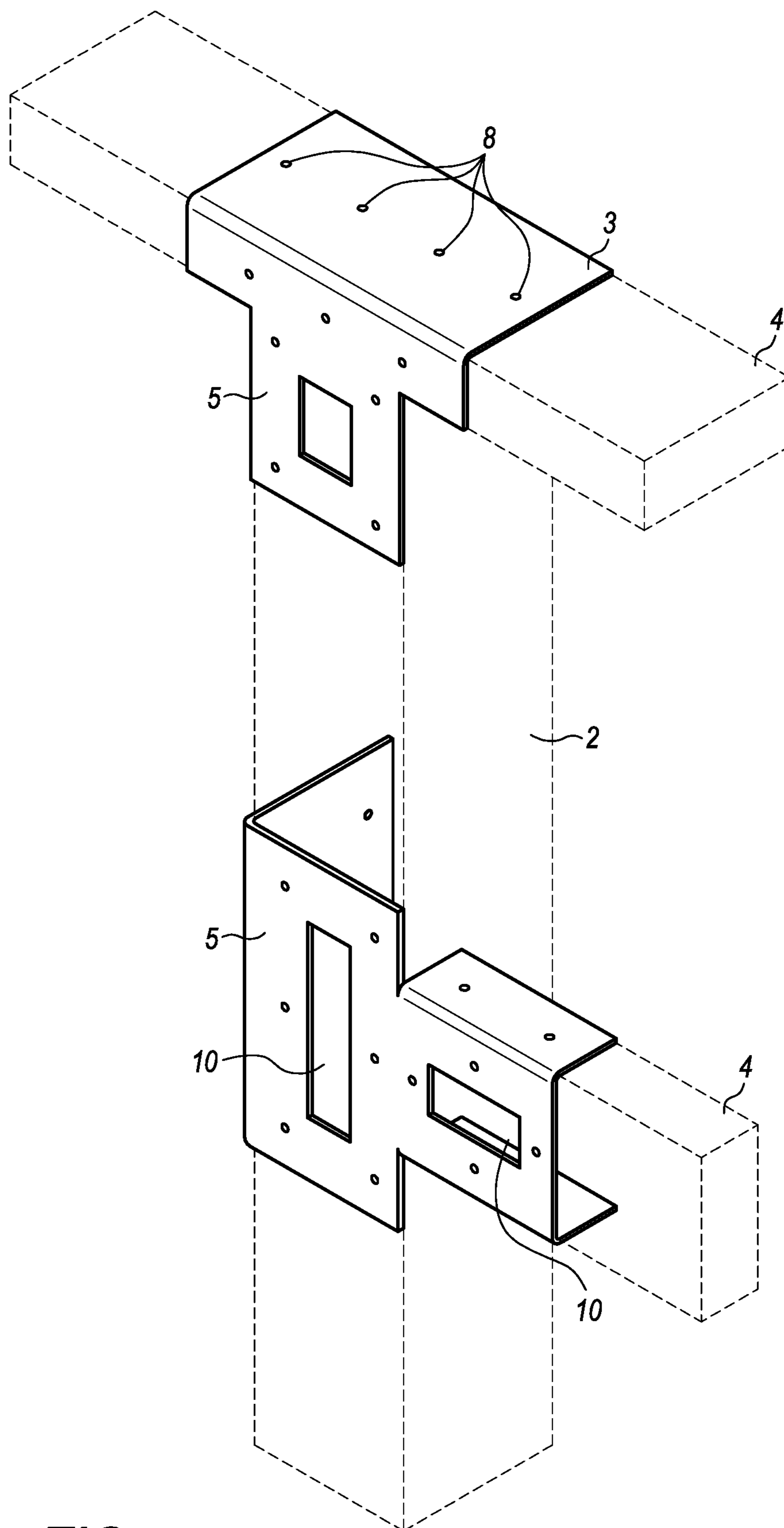

FIG. 5

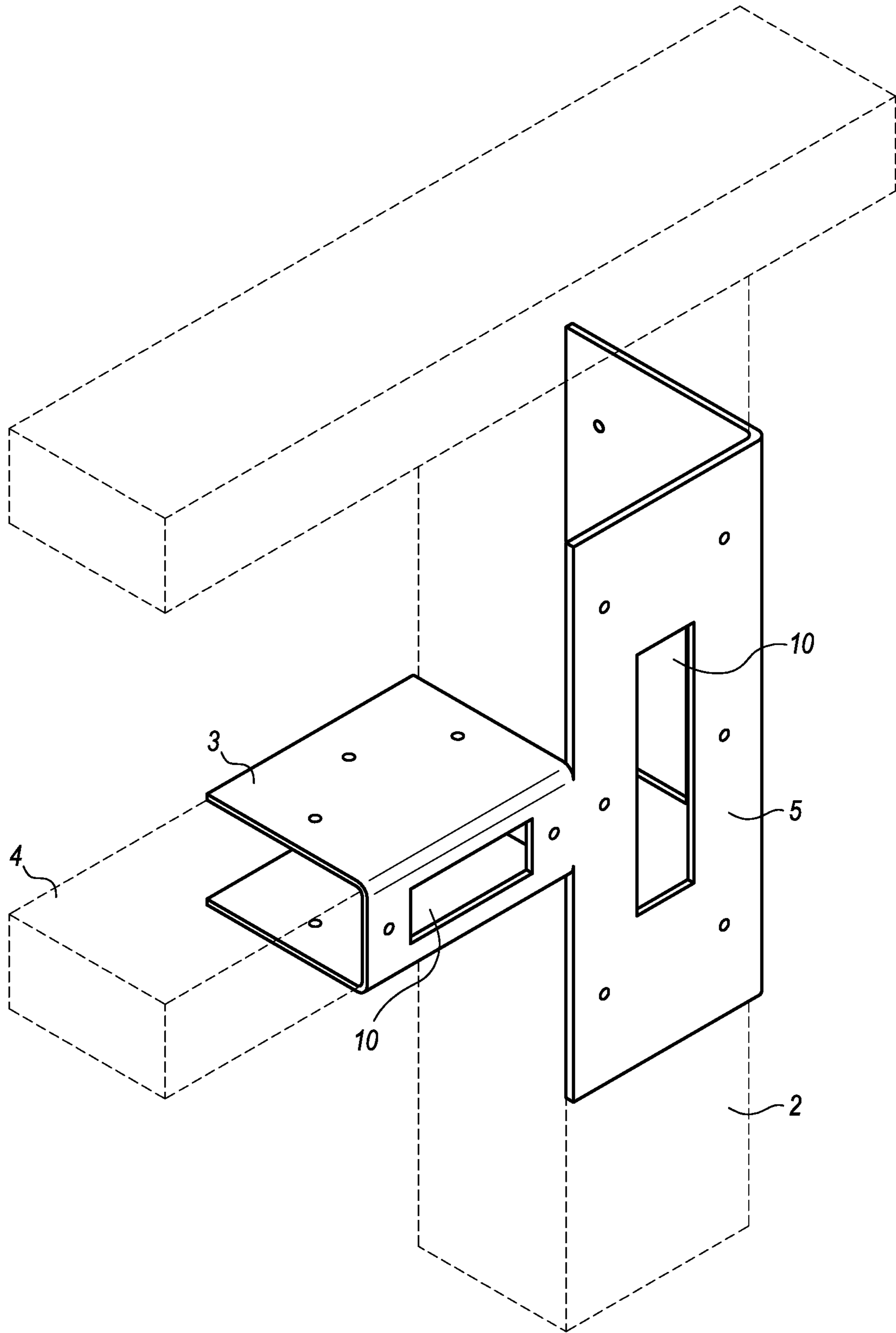

FIG. 6

1**FENCE BRACE SYSTEM**

FIELD OF THE INVENTION

The present invention relates to the field of fences. More particularly, the present invention relates to the field of systems for providing structural support for fences.

BACKGROUND OF THE INVENTION

Fence and fence structures are subject to damage due to high winds, torrential rains, heavy snowfall, vehicular accidents, termites, vandalism, earthquakes and falling trees and branches. The most common of these causes is high winds. Wind damages fences all around the world every year. Fences made of wood are especially susceptible to wind damage because wood is weakened by prolonged exposure to rain, snow, wind, and other elements. Despite the potential for damage, wood is still by far the most common residential fencing material in the United States. In 2007 alone, Americans put up 59,000 miles of wood fencing, enough to circle the globe twice. Wood is inexpensive and lightweight and a wood fence can easily be shaped to give properties character and individuality. There are many styles, including linear post-and-rail and crisscrossing lattice, as well as myriad picket patterns and post-cap designs. And the wood may be painted or stained to match almost any landscape.

Fences could be built much stronger through the use of heavy materials such as steel and sturdy construction. However, this might drive the cost of the fence up above what is acceptable. As well, there are the aesthetic considerations discussed above. Also, it is unlikely that a property owner would replace an existing fence merely because of the possibility that it could be damaged by the elements.

Therefore there is an unmet need for an inexpensive way to provide a fence with additional structural support. The need is especially great with respect to existing fences and with respect to wooden fences.

SUMMARY OF THE INVENTION

The present invention fills the needs described above. It provides a way for an existing fence to be strengthened. The fence would not need to be removed or modified to install the brace. Installation would be simple. The brace could be mass produced at low cost. The color and style of the brace could be easily adapted to mesh aesthetically with the fence and the surrounding area. The brace itself may be painted or stained. The brace may also be built into a new fence. The present invention optionally includes embodiments adapted for fences with rectanguloid rails or for rectanguloid fence posts. The present invention may be optionally optimized for a fence with cylindrical fence posts. The present invention also may include an embodiment adapted to secure the corner pieces of the fence. In an additional optional embodiment, the present invention is adapted to secure a fence on a slope. The brace may be made of strong weather-resistant material such as steel, stainless steel, galvanized steel, aluminum, plastic, graphite, composite material, or wood.

BRIEF DESCRIPTION OF THE DRAWINGS

FIG. 1 shows a fence brace according to the present invention that supports a connection between a rectanguloid fence post to 2 linearly disposed rectanguloid fence rails according to the present invention.

2

FIG. 2. Shows a fence brace according to the present invention that supports a connection between a rectanguloid fence rail and a cylindrical fence post.

FIG. 3A shows an fence brace according to the present invention adapted to support the connection between a rectanguloid fence rail to a rectanguloid fence post disposed on a slope pictured prior to the brace being secured.

FIG. 3B shows the embodiment of FIG. 3A in a secured position.

FIG. 4 shows 2 embodiments of a fence brace according to the present invention adapted to support the connection 2 rectanguloid fence rails to a rectanguloid fence post at (for instance) a corner.

FIG. 5 shows alternate embodiments of the brace according to the present invention adapted to support the connection between a rectanguloid fence post and a rectanguloid fence rail.

FIG. 6 shows an alternate embodiment of the brace according to the present invention adapted to support the connection between a rectanguloid fence post and a rectanguloid fence rail.

DETAILED DESCRIPTION OF THE INVENTION

In the following detailed description of the preferred embodiment, reference is made to the accompanying drawings, which from a part of this application. The drawings show, by way of illustration, specific embodiments in which the invention may be practiced. It is to be understood that other embodiments may be utilized and structural changes may be made without departing from the scope of the present invention.

The following is a listing of the reference numbers included in the original drawings and the element that each reference number corresponds to and a brief description:

1. A fence brace.
2. A fence post.
3. A first fence rail brace member.
4. A first fence rail.
5. A fence post brace member.
6. A second fence rail brace member
7. A second rectanguloid fence rail.
8. A plurality of holes.
9. At least one board.
10. A slot.
11. An arc-shaped fence post brace member.
12. A first corner piece.
13. A second corner piece.
14. A screw.
15. A screw hole.
16. A perpendicularly disposed flap.
17. A second fence rail.

In a first embodiment as best shown in FIG. 1, FIG. 5 and FIG. 6, the present invention comprises a fence brace for securing at least one fence rail to a fence post including a first fence rail brace member adapted to connect to 2 or more sides of a first fence rail. The first fence rail brace member may be fused to a first side of a fence post brace member, the fence post brace member being adapted to connect to 2 or more sides of the fence post. The fence rail may be rectanguloid. As used herein, the term "rectanguloid" means a solid (3-dimensional) object which has six faces that are rectangles. It has the same cross-section along a length. As used herein, a "rectanguloid" is the same as a "rectangular prism." A rectanguloid may be thought of as a 3 dimensional version of a rectangle or a square. Where the fence post is

3

rectanguloid, the present invention would further include a second fence rail brace member fused to a second side of the fence post brace member, the second fence rail brace member being adapted to connect to 2 or more sides of a second rectanguloid fence rail. The present invention may optionally include a second fence rail brace member fused to a second side of the fence post brace member, the second fence rail brace member being adapted to connect to 2 or more sides of the rectanguloid fence rail. The fence brace may include a plurality of holes thereby allowing the fence post brace member to be securely fastened to the fence post and thereby allowing the fence rail brace member to be securely fastened to the fence rails. The brace may be made of a strong weather-resistant material such as selected from the group consisting of steel, stainless steel, galvanized steel, aluminum, plastic, graphite, composite material, or wood. The first embodiment of the present invention may further include at least one board, wherein the fence post brace member has a slot, and the board is to be fastened to the fence post by passing a screw through the board and through the slot and into the fence post. As well, the brace may include at least one board, wherein the fence post brace member has a slot, and the board is fastened to the fence rail by passing a screw through the board and through the slot and into the fence rail. FIG. 5 at the top shows this embodiment where the fence rail passes above the top of the fence post. FIG. 5 at the bottom shows this embodiment where the fence rail terminates at the fence post. FIG. 6 shows an alternate view of this embodiment where the fence rail terminates at the fence post.

In a second embodiment as best shown in FIG. 2, the present invention is adapted for use with a fence having cylindrical fence posts. Therefore, the fence brace is adapted to secure at least one rectanguloid fence rail to a cylindrical fence post. Specifically, a first fence rail brace member is adapted to connect to 2 or more sides of a first rectanguloid fence rail. The first fence rail brace member is fused to a first side of an arc-shaped fence post brace member, the arc shaped fence post brace member being adapted to surround the cylindrical fence post. A second side the arc-shaped fence post brace member connects to the fence rail. Optionally, a second fence rail brace member adapted to connect to 2 or more sides of the first rectanguloid fence rail, wherein the second fence rail brace member is fused to a second side of the arc-shaped fence post brace member. This second embodiment may further include a second fence rail brace member adapted to connect to 2 or more sides of a second rectanguloid fence rail, wherein the second fence rail brace member is fused to a second side of the arc-shaped fence post brace member.

As in the first embodiment, the fence brace further may include a plurality of screw-holes, nail holes, bolt holes or other such holes. This allows the fence post brace member to be securely fastened to the fence post and thereby allowing the fence rail brace member to be securely fastened to the fence rails.

In a third embodiment as shown in FIGS. 3A and 3B, the fence brace is adapted to secure a rectanguloid fence post to a rectanguloid fence rail on a slope. This embodiment includes a fence rail brace member adapted to connect to 2 or more sides of a first rectanguloid fence rail. It further includes a fence post brace member adapted to connect to 2 or more sides of the rectanguloid fence post. The fence post brace member has a slot and 2 or more screws may be included. The fence rail brace member has at least one screw hole disposed underneath the slot of the fence post brace member, and the screw passes through the slot of the fence

4

post brace member, and then through the screw hole of the fence rail brace member into the fence post, thereby allowing the fence post brace member to be securely fastened to the fence rail brace member and to the fence post. Optionally, the fence brace is made of weather-resistant material such as steel, stainless steel, galvanized steel, aluminum, plastic, graphite, composite material, and wood. Optionally, at least one board may be included, wherein the fence rail brace member has a slot, and the board is fastened to the fence rail by passing a screw through the board and through the slot and into the fence rail. As well, the fence brace may include a plurality of holes thereby allowing the fence post brace member to be securely fastened to the fence post and thereby allowing the fence rail brace member to be securely fastened to the fence rails.

In a fourth embodiment as best shown in FIG. 4, the fence brace is adapted to secure 2 rectanguloid fence rails to a rectanguloid fence post at an angle. Without limitation, this embodiment would be useful for securing the corner of a rectangularly fenced off yard. This embodiment includes a first fence rail brace member adapted to connect to 2 or more sides of a rectanguloid fence rail, and a second fence rail brace member adapted to connect to 2 or more sides of the a second rectanguloid fence rail. The second fence rail brace member is fused to a first end of the first fence rail brace member, and the first fence rail brace member has at least one perpendicularly fused flap disposed to connect the first fence rail brace member to the rectanguloid fence post. The second fence rail brace member has at least one perpendicularly fused flap disposed to connect the second fence rail brace member to the rectanguloid fence post. As in earlier embodiments, a plurality of screw-holes, nail holes, bolt holes, or other such holes may be included thereby allowing the fence post brace member to be securely fastened to the fence post and thereby allowing the fence rail brace member to be securely fastened to the fence rails.

In a fifth embodiment as best shown in FIG. 4, the fence brace is adapted to secure 2 rectanguloid fence rails to a rectanguloid fence post at an angle. There is a first fence rail brace member adapted to connect to 2 or more sides of a rectanguloid fence rail. The second fence rail brace member is adapted to connect to 2 or more sides of a second rectanguloid fence rail. There is a first corner piece and a first side of the first corner piece is fused to a first side of the first fence rail brace member a second corner piece wherein a first side of the second corner piece is fused to a first side of the second fence rail brace member. The second side of the first corner piece is fused to the second side of the second corner piece at a right angle.

Although the description above contains many specifications, these should not be construed as limiting the scope of the invention but as merely providing illustrations of some of the embodiments of this invention. Thus, the scope of the invention should be determined by the appended claims and their legal equivalents rather than by the examples given.

What is claimed is:

1. A fence assembly comprising:

a corner fence post having a rectangular cross-section and defining a pair of inner corner faces and a pair of outer corner faces thereof;

first and second fence rails, each having a rectangular cross-section and defining inner and outer faces thereof;

a fence brace comprising:

a pair of left and right fence rail flanges arranged at a right angle, each of the fence rail flanges comprising a planar central wall and a pair of rearward-protruding side

5

walls extending along opposing horizontal longitudinally-extending edges of the central wall, the sidewalls of the left fence rail flange being horizontally-aligned with the sidewalls of the right fence rail flange to define a pair of channels arranged at a right angle for receiving the fence rails therein, and a plurality of fastener holes disposed within the central wall and side walls of each fence rail flange for receiving fasteners to secure the fence rails therewith;

a first planar corner piece, wherein a first side of the first corner piece is connected to a first side of the left fence rail flange and wherein the first corner piece contains a plurality of fastener holes disposed therein for receiving fasteners to secure the fence post therewith;

a second planar corner piece, wherein a second side of the second corner piece is connected to a first side of the right fence rail flange, wherein the second corner piece contains a plurality of fastener holes disposed therein for receiving fasteners to secure the fence post therewith, and wherein a second side of the first corner piece is connected to a first side of the second corner piece at a right angle to define a channel for receiving the fence post therein;

6

wherein the first and second corner pieces are secured to the inner corner faces of the fence post and the fence rails are secured within the fence rail flanges such that the outer faces of the fence rails are substantially flush with the outer corner faces of the fence post;

at least one picket fastened to at least one of the outer corner faces of the fence post by passing a fastener through the picket into the fence post; and

at least one picket fastened to the outer face of the fence rail corresponding to the at least one outer corner face of the fence post by passing a fastener through the picket and into the fence rail;

wherein the pickets are fastened to the fence post and fence rail such that the pickets are substantially in planar alignment with one another.

2. The fence assembly of claim 1, wherein the fence brace is made of a material selected from the group consisting of steel, stainless steel, galvanized steel, aluminum, plastic, graphite, and composite material.

* * * * *