



US010718476B2

(12) **United States Patent**
Santos et al.

(10) **Patent No.:** **US 10,718,476 B2**
(45) **Date of Patent:** **Jul. 21, 2020**

(54) **LED LIGHT FIXTURE FOR INDIRECT LIGHTING WITH ADAPTABLE BAFFLE STRUCTURE**

(71) Applicant: **FINELITE INC.**, Union City, CA (US)

(72) Inventors: **Arlan R. Santos**, Milpitas, CA (US); **David Daoud Aziz**, Pleasanton, CA (US); **Johannes Dale Toale**, San Jose, CA (US); **My Tien Nguyen**, Redwood City, CA (US); **Aaron Matthew Smith**, Fremont, CA (US); **Kyle Tomas Martin**, Fremont, CA (US); **Timothy Shepard**, Alameda, CA (US); **Wenhui Zhang**, Shanghai (CN)

(73) Assignee: **Finelite INC.**, Union City, CA (US)

(*) Notice: Subject to any disclaimer, the term of this patent is extended or adjusted under 35 U.S.C. 154(b) by 0 days.

(21) Appl. No.: **16/501,832**

(22) Filed: **Jun. 13, 2019**

(65) **Prior Publication Data**

US 2019/0309917 A1 Oct. 10, 2019

Related U.S. Application Data

(63) Continuation-in-part of application No. 16/501,180, filed on Mar. 1, 2019, now Pat. No. 10,670,205.

(60) Provisional application No. 62/761,131, filed on Mar. 9, 2018.

(51) **Int. Cl.**

F21S 4/20 (2016.01)
F21V 5/04 (2006.01)
F21V 7/04 (2006.01)
F21V 7/00 (2006.01)

F21V 3/00 (2015.01)
F21V 15/01 (2006.01)

(52) **U.S. Cl.**

CPC **F21S 4/20** (2016.01);
F21V 3/00 (2013.01); **F21V 5/04** (2013.01);
F21V 7/005 (2013.01); **F21V 7/0008**
(2013.01); **F21V 7/0025** (2013.01); **F21V 7/04**
(2013.01); **F21V 15/01** (2013.01)

(58) **Field of Classification Search**

CPC **F21S 4/20**; **F21S 6/008**; **F21V 7/0008**;
F21V 7/0016-005; **F21V 15/01**; **F21K**
9/62; **F21K 9/68**
See application file for complete search history.

(56) **References Cited**

U.S. PATENT DOCUMENTS

8,436,375 B2* 5/2013 Miura **F21V 15/013**
257/678
2005/0207166 A1* 9/2005 Kan **F21V 5/002**
362/373

(Continued)

Primary Examiner — Mariceli Santiago

(74) *Attorney, Agent, or Firm* — James A. Gavney, Jr.;
JAG Patent Services

(57) **ABSTRACT**

An LED light fixture is disclosed with an elongated housing that forms a open lower light channel and an upper light channel that is juxtaposed to the open lower light channel with electronics cavity or conduit positioned there between. The LED light fixture preferably has an elongated reflective insert that extends through the open lower light channel and creates a reflection channel from which the indirect and reflected light is emitted and a detachable cover structure that includes a diffusion lens and a removable baffle structure that attaches to side walls of the upper light channel.

11 Claims, 12 Drawing Sheets

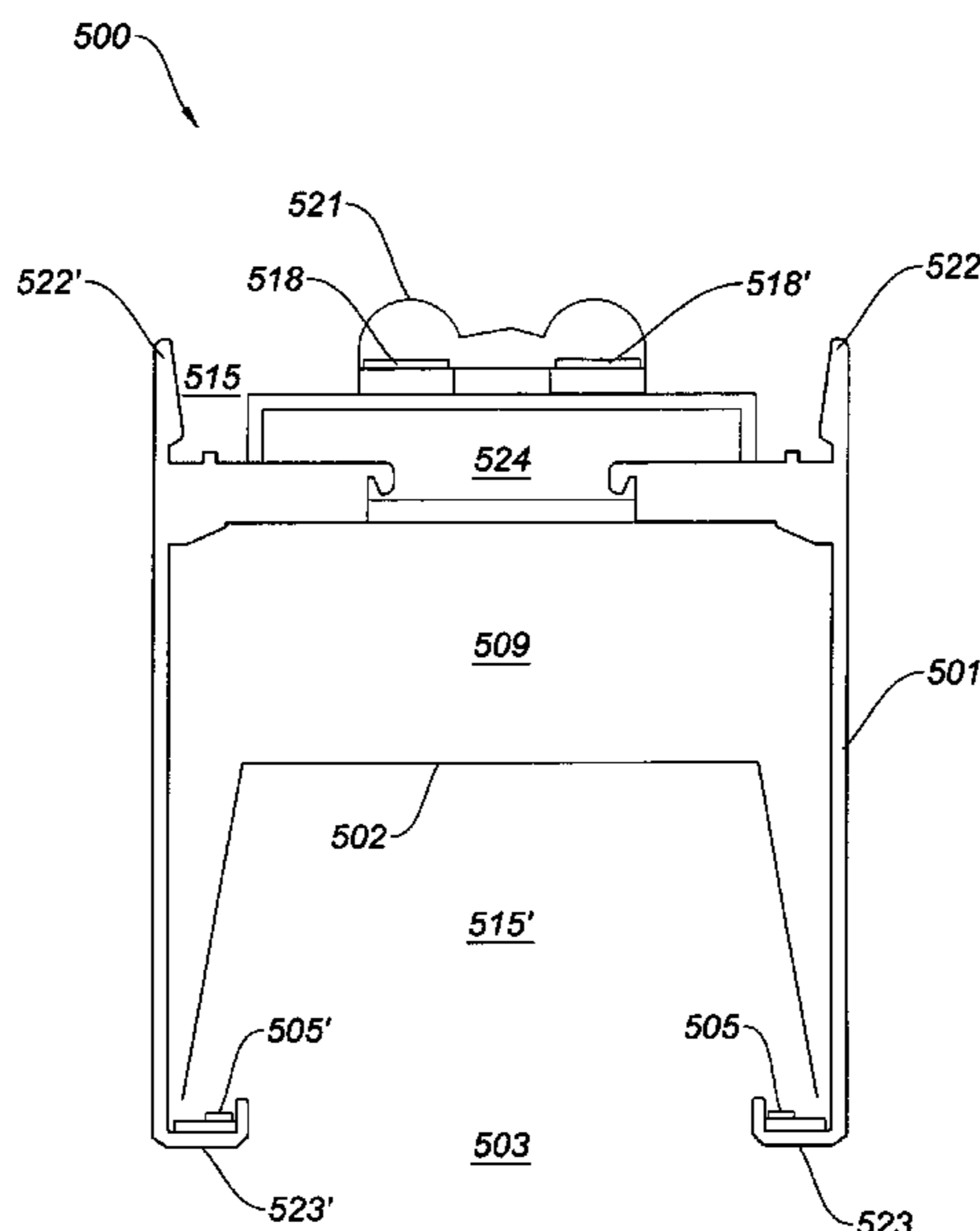

(56)

References Cited

U.S. PATENT DOCUMENTS

2011/0002116 A1* 1/2011 Chen F21V 7/0016
362/235
2011/0002682 A1* 1/2011 Messina F21V 7/0008
396/200
2011/0058377 A1* 3/2011 Chou F21V 3/02
362/294
2015/0241023 A1* 8/2015 Kim F21S 8/03
362/296.05
2015/0345743 A1* 12/2015 Trincia F21V 7/0091
362/223
2016/0305631 A1* 10/2016 Hansen F21V 7/0016
2018/0172219 A1* 6/2018 Van Bommel F21K 9/237

* cited by examiner

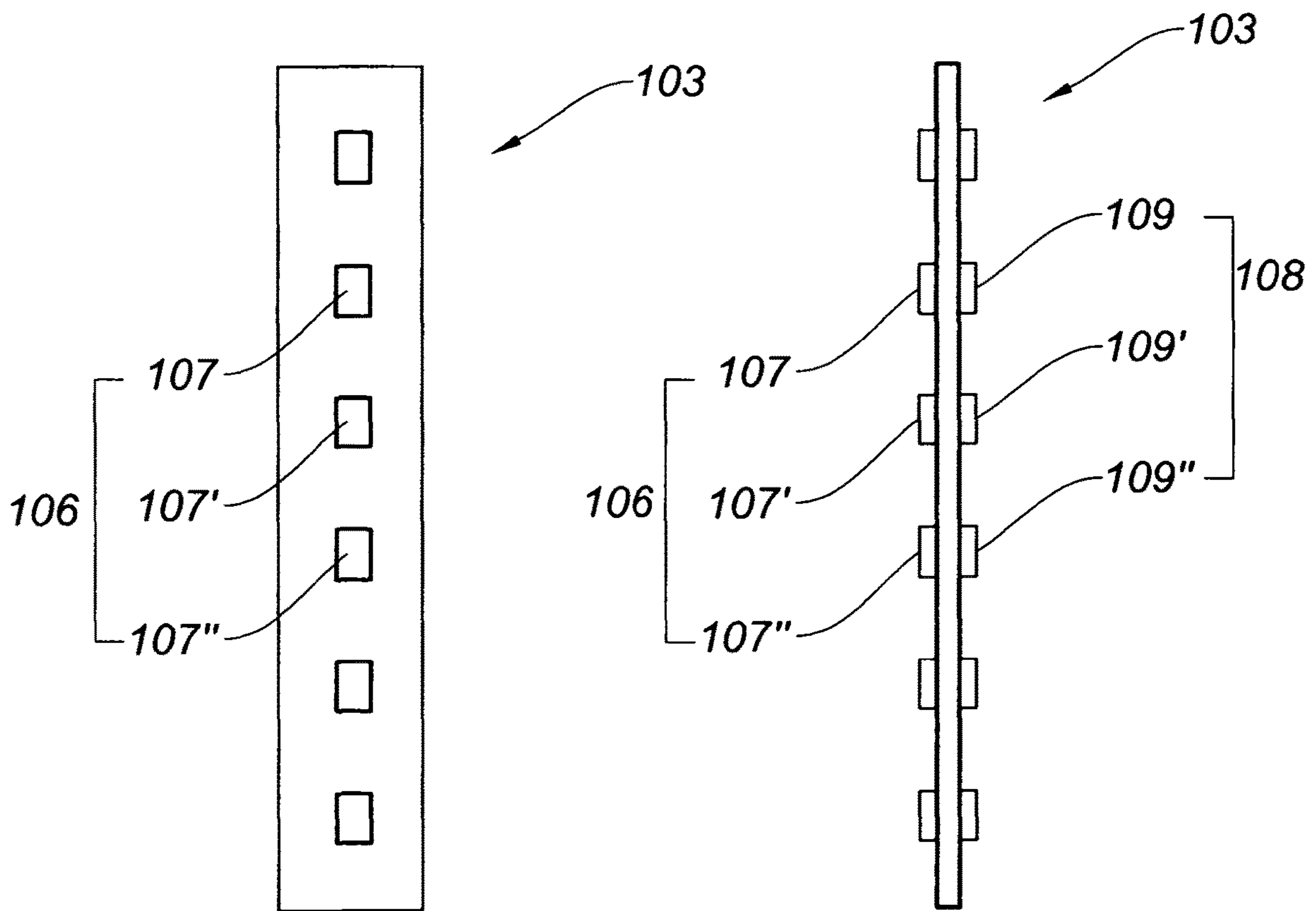
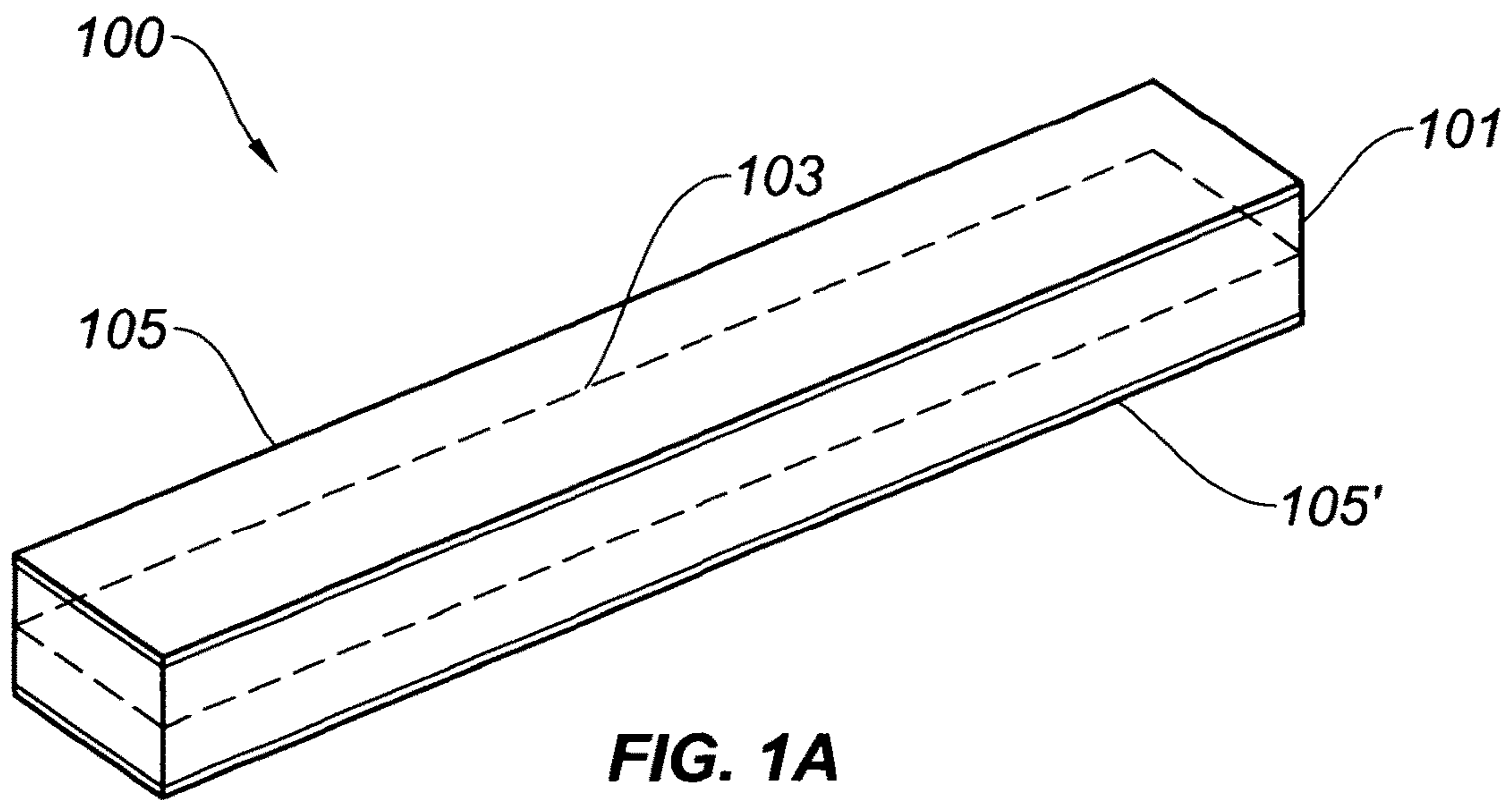

FIG. 1B

FIG. 1C

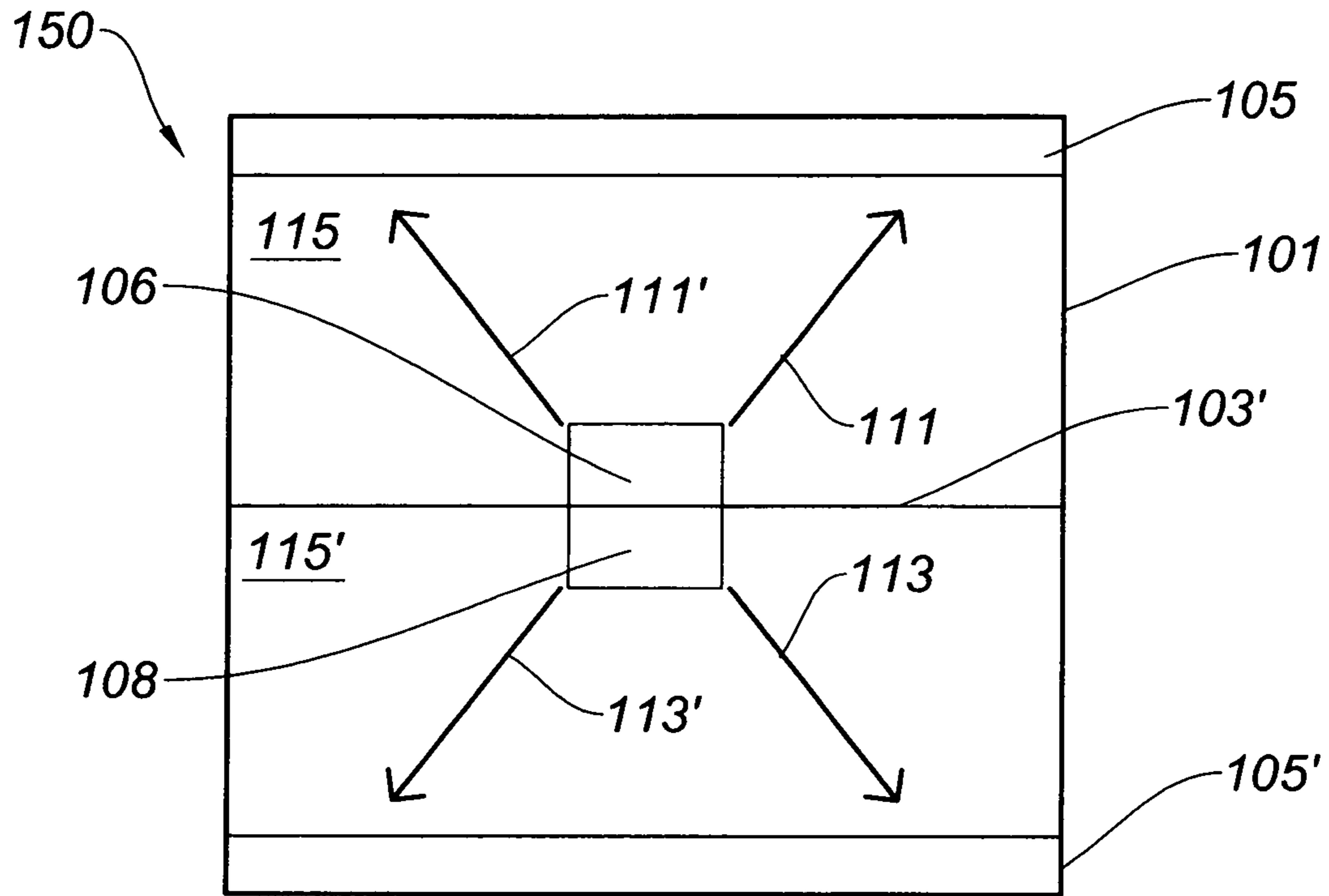

FIG. 1D

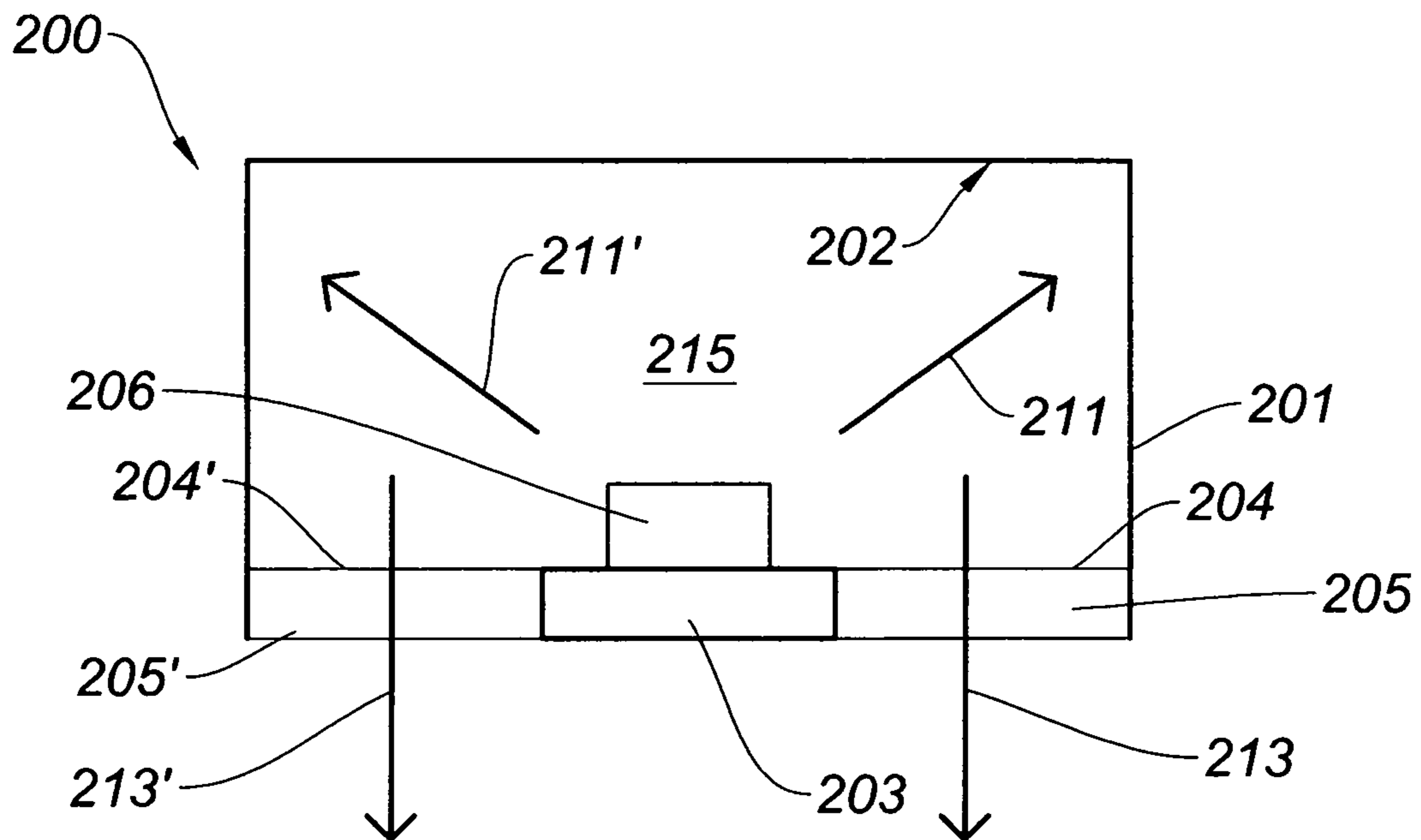

FIG. 2

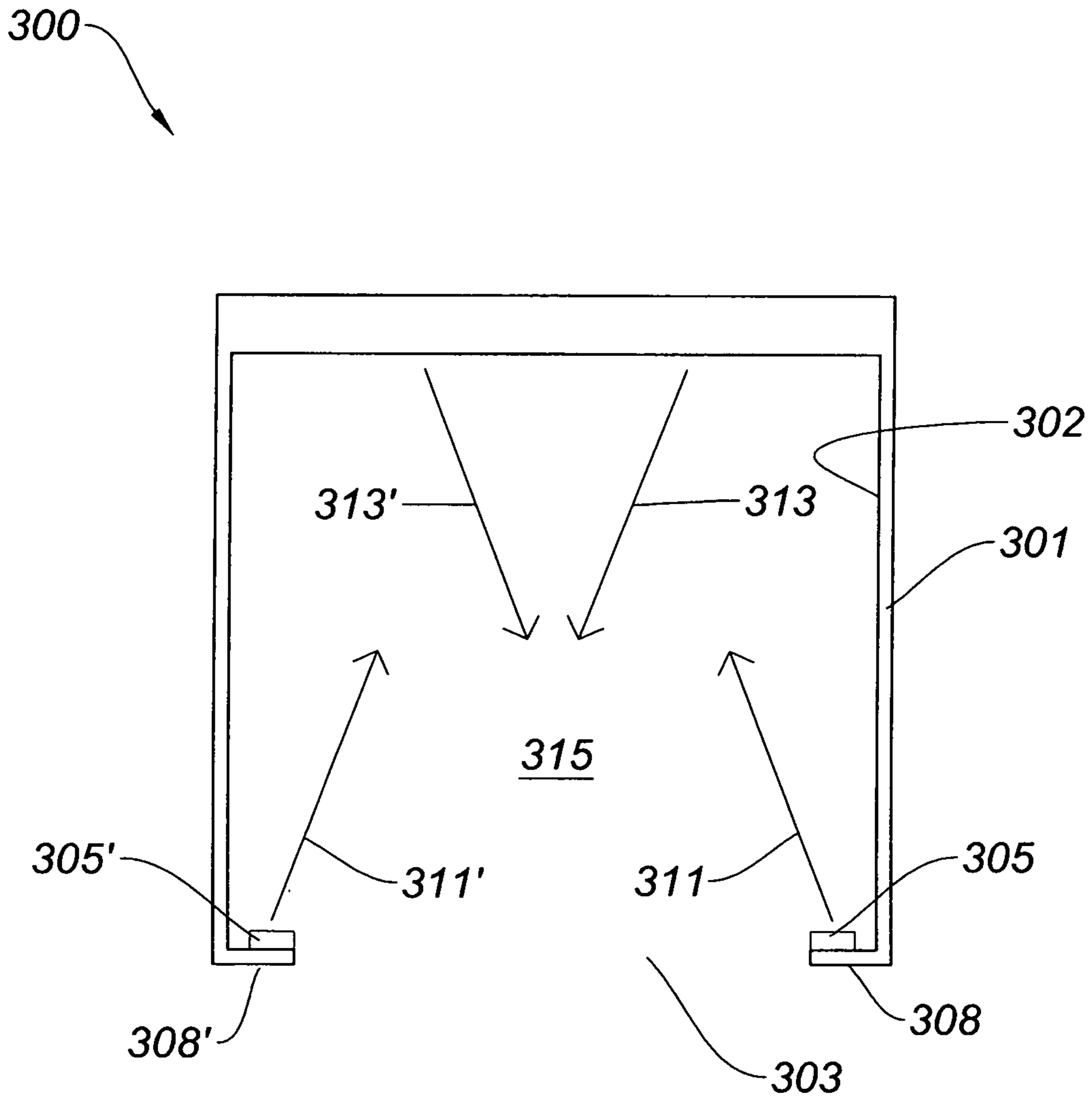

FIG. 3A

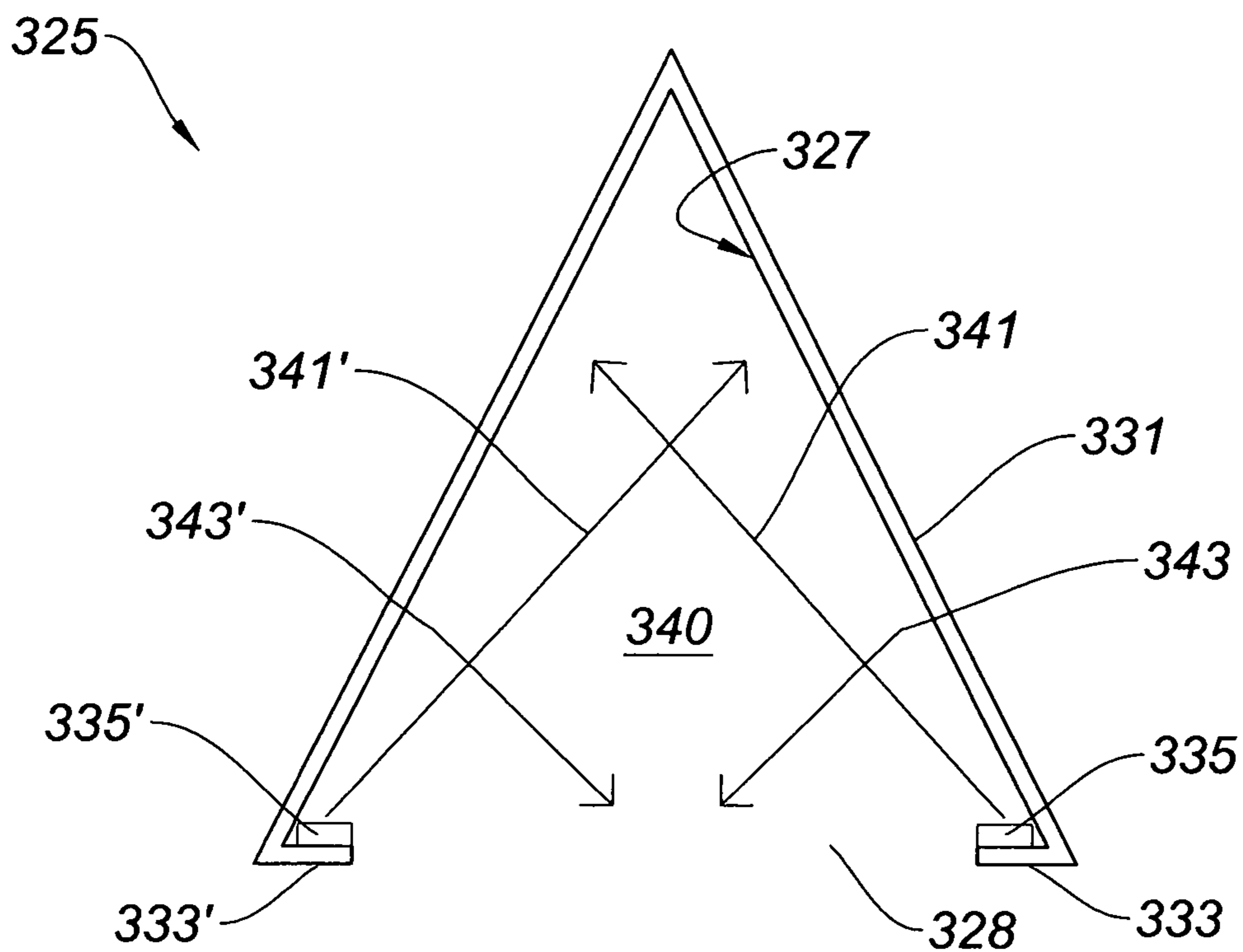

FIG. 3B

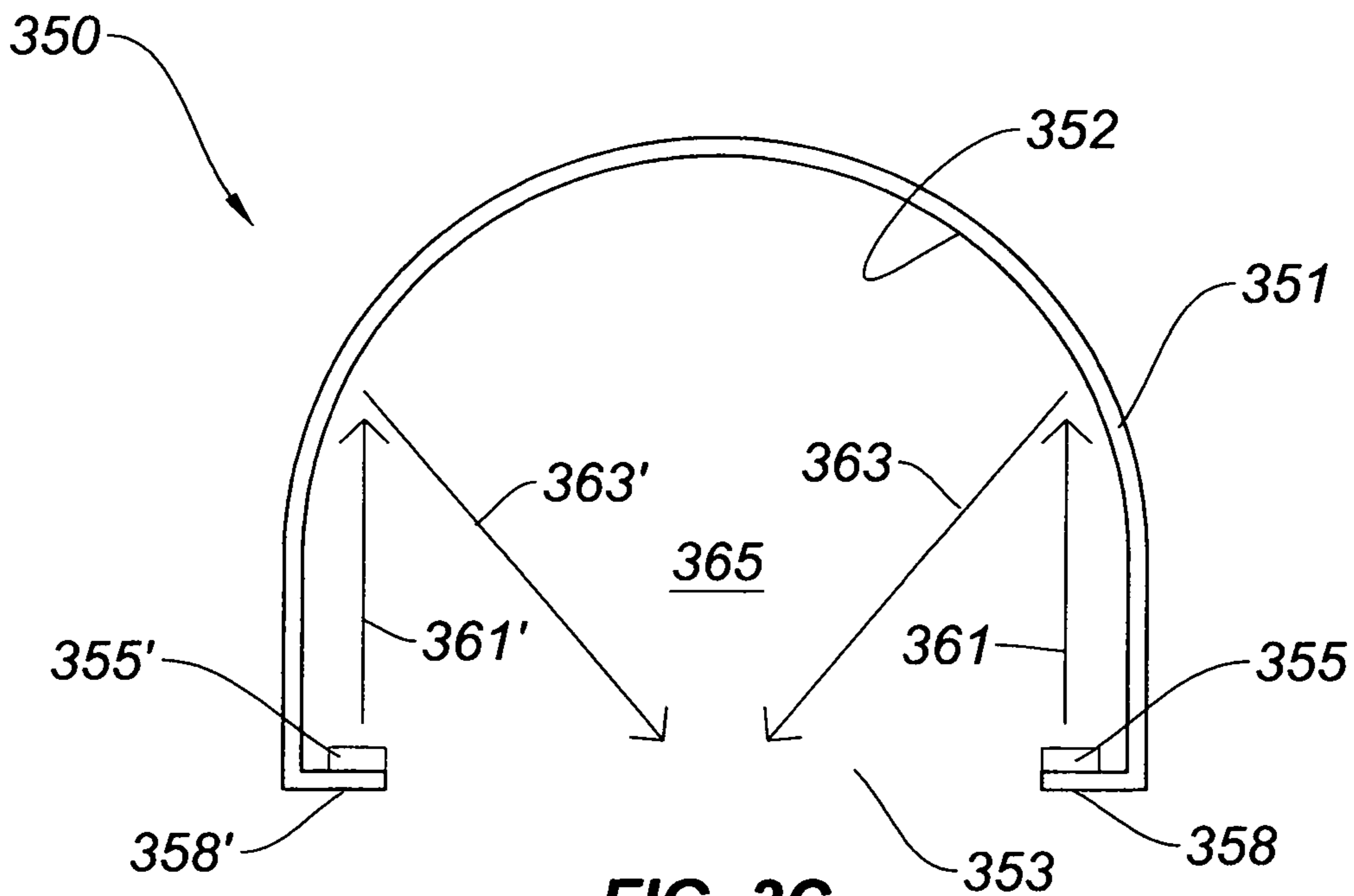
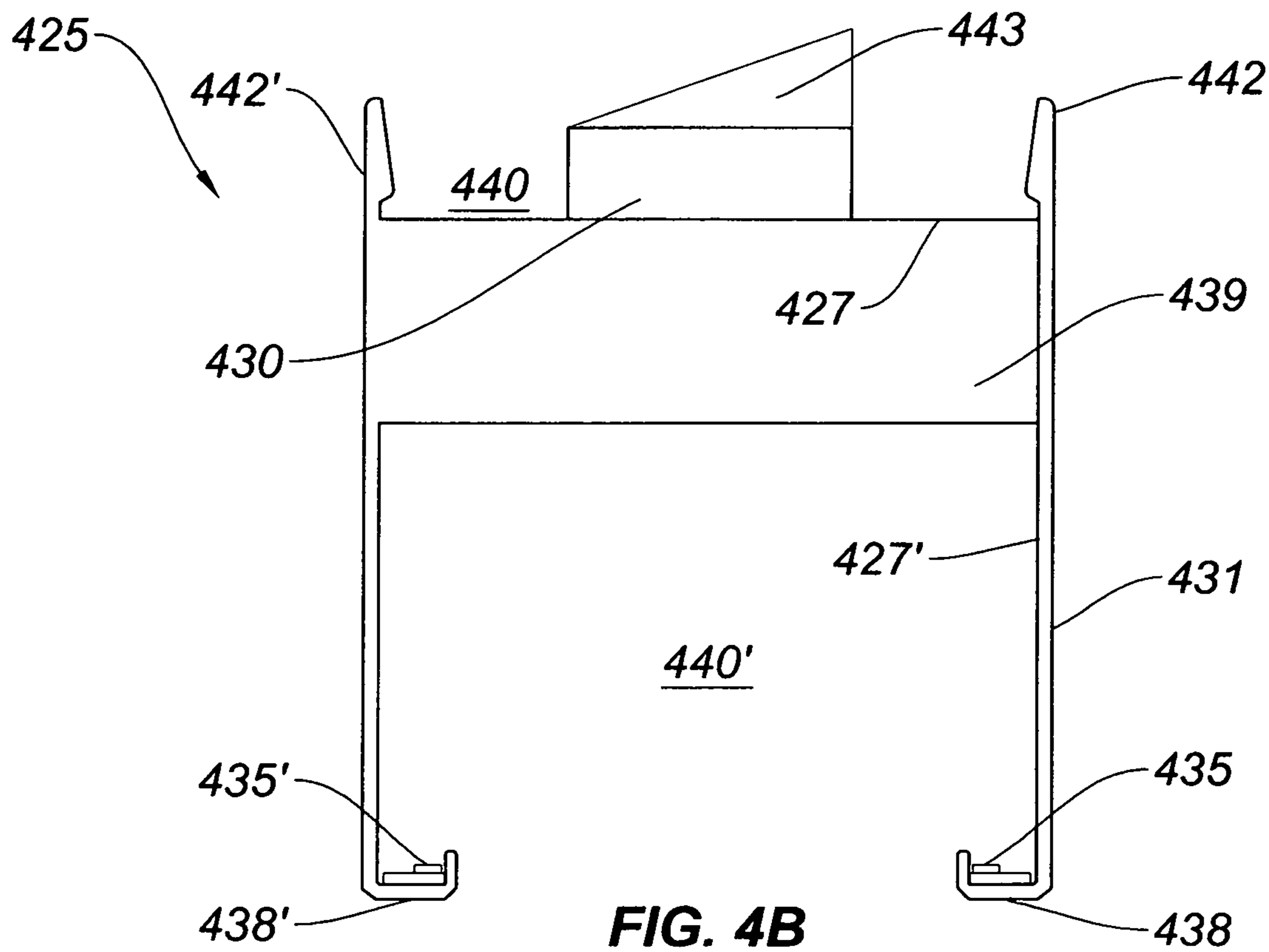
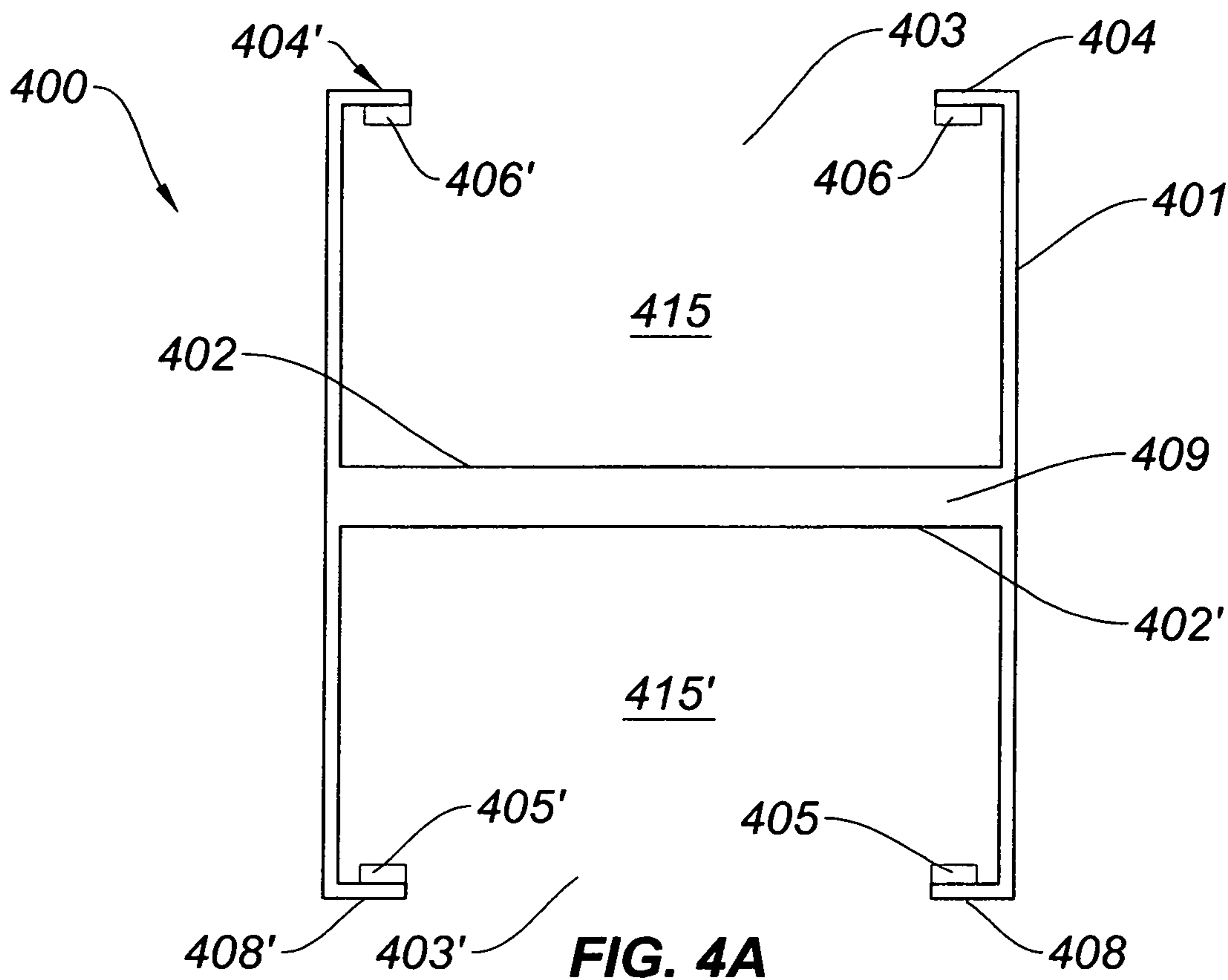

FIG. 3C



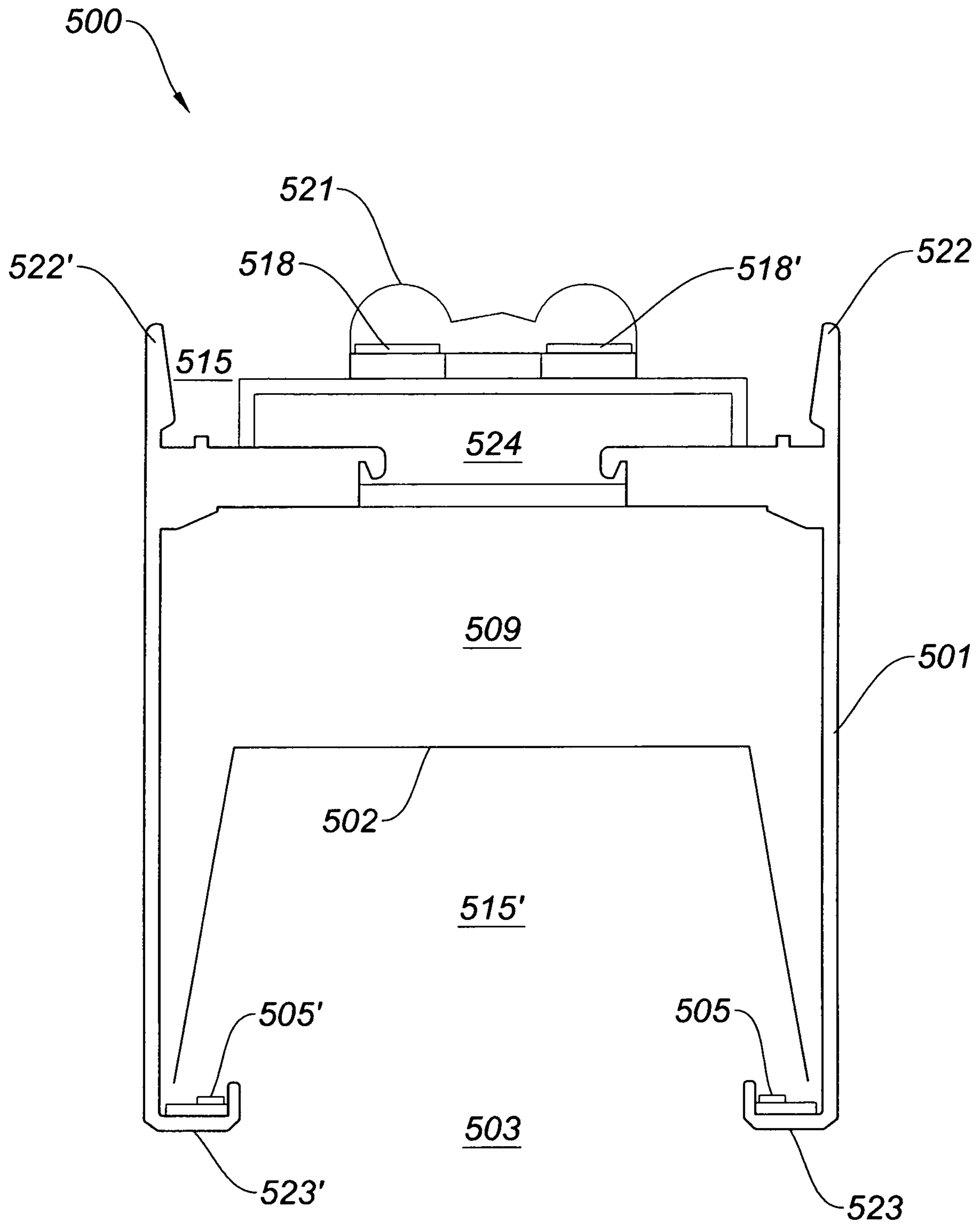

FIG. 5A

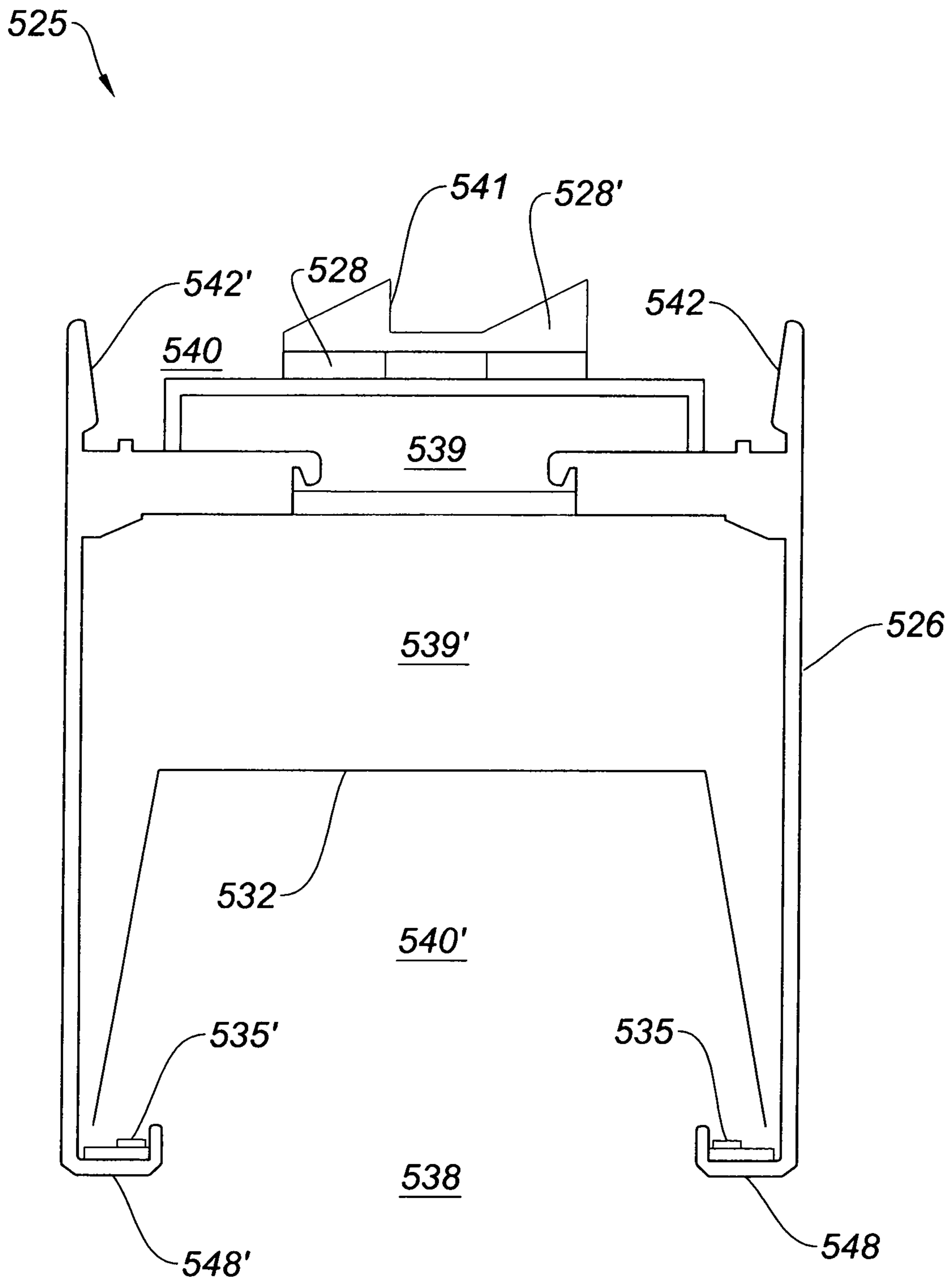

FIG. 5B

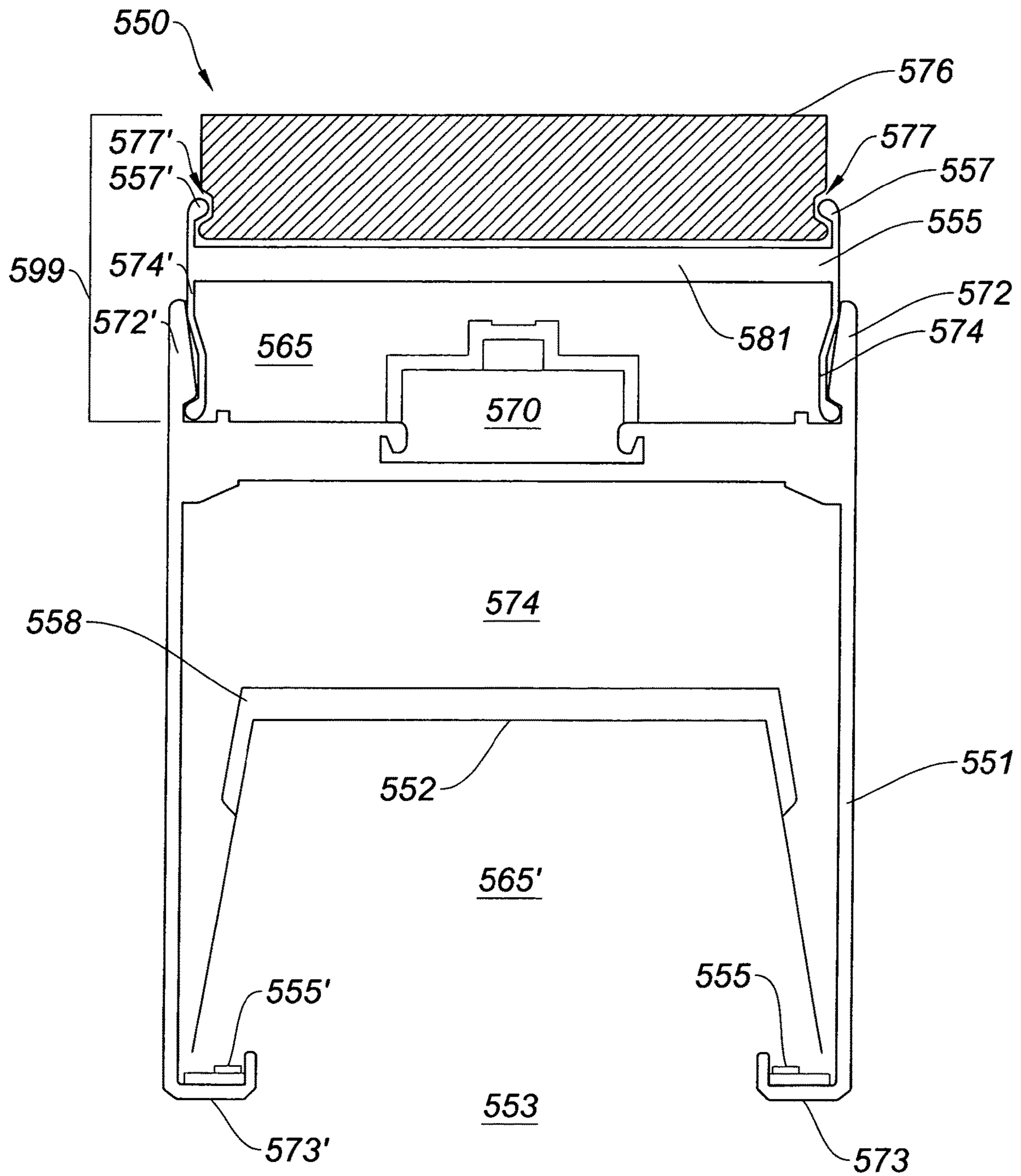

FIG. 5C

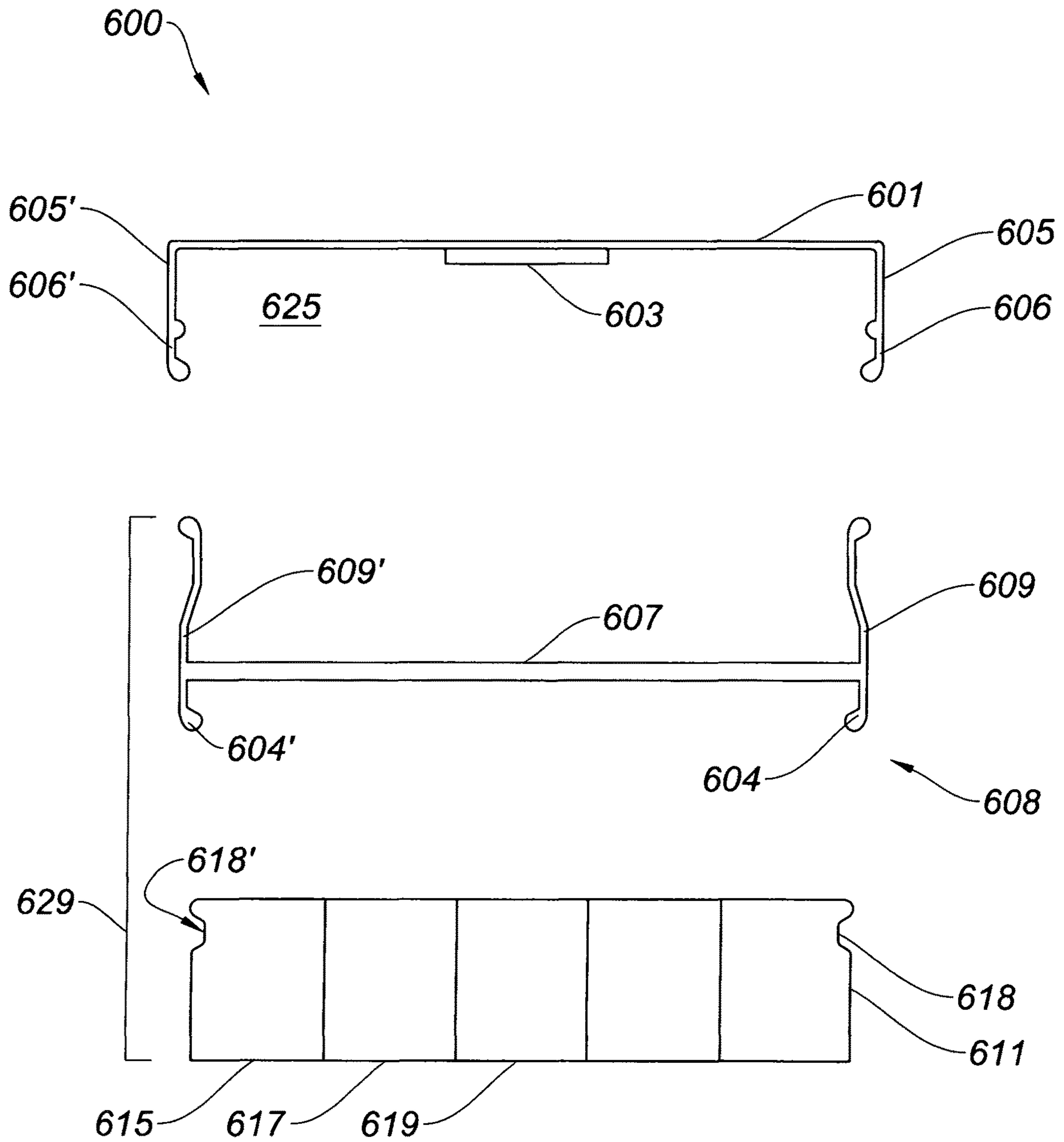

FIG. 6A

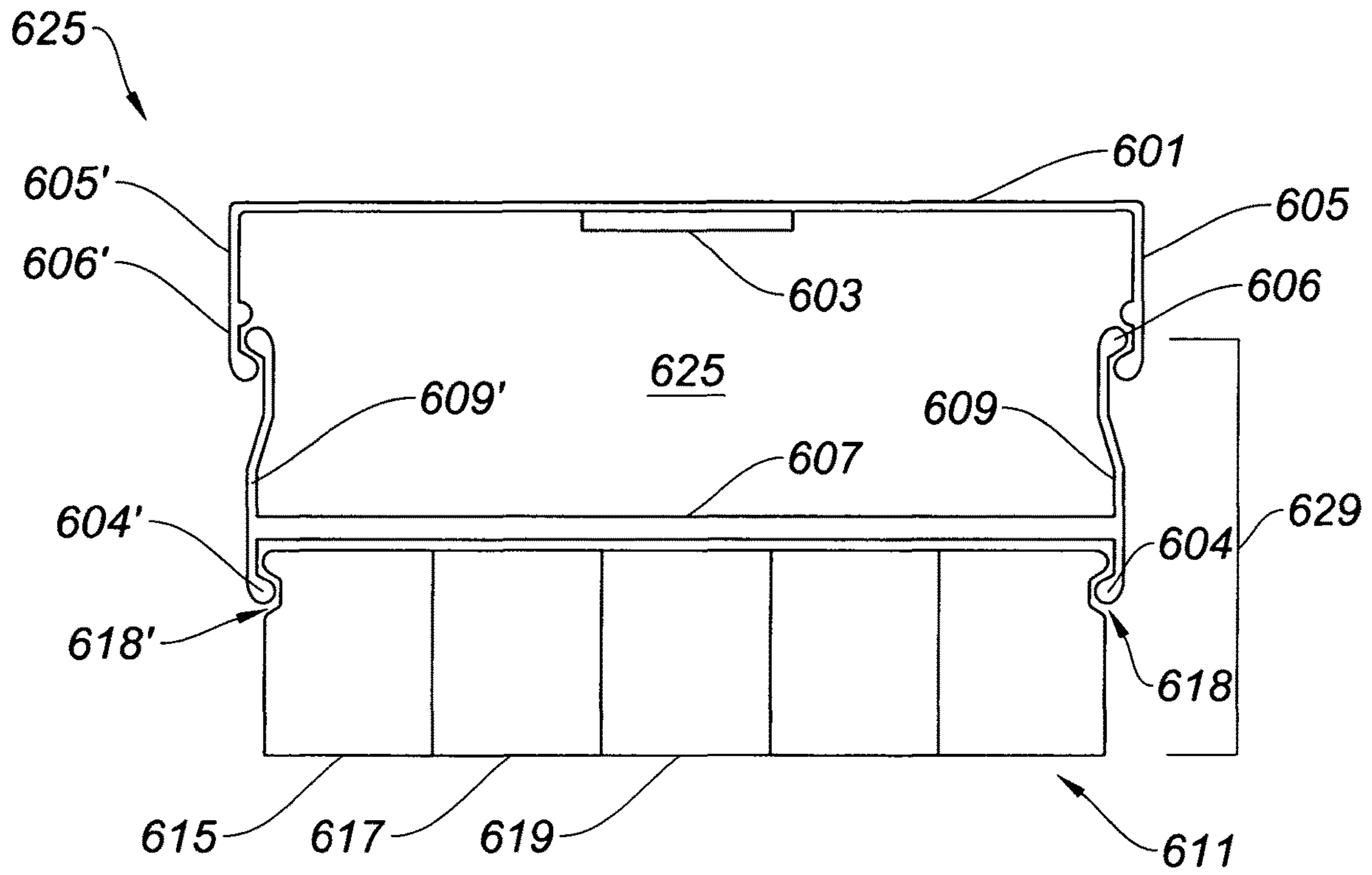

FIG. 6B

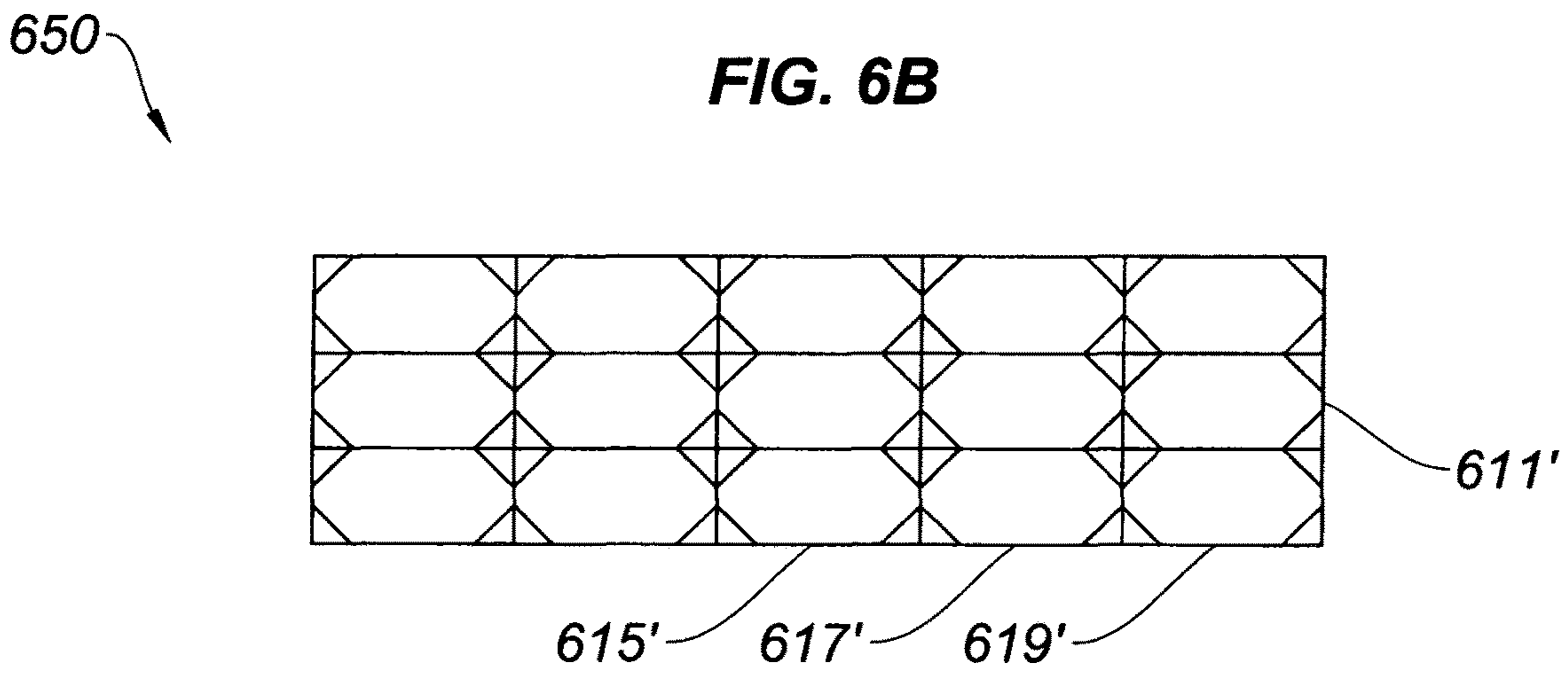

FIG. 6C

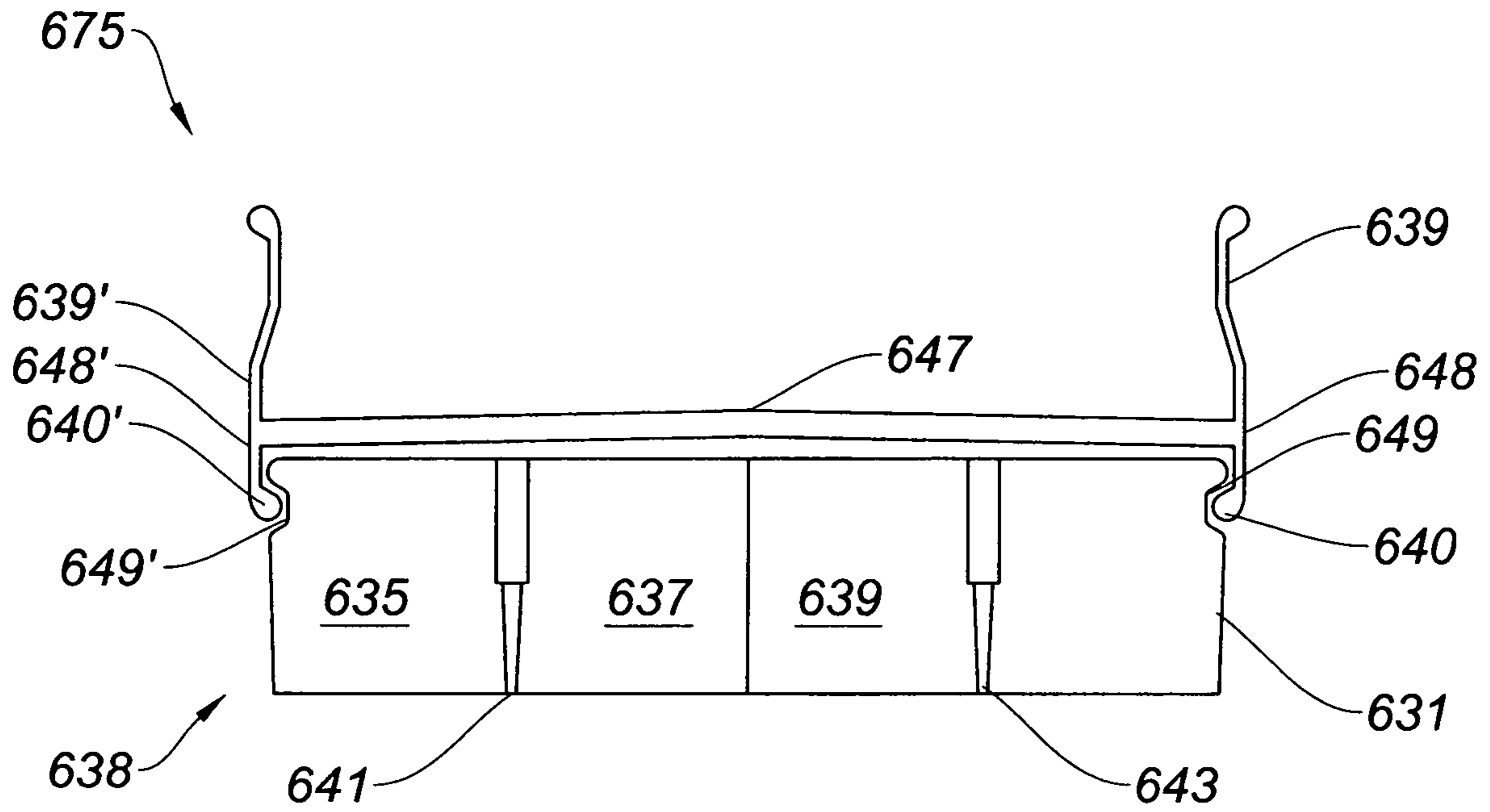

FIG. 6D

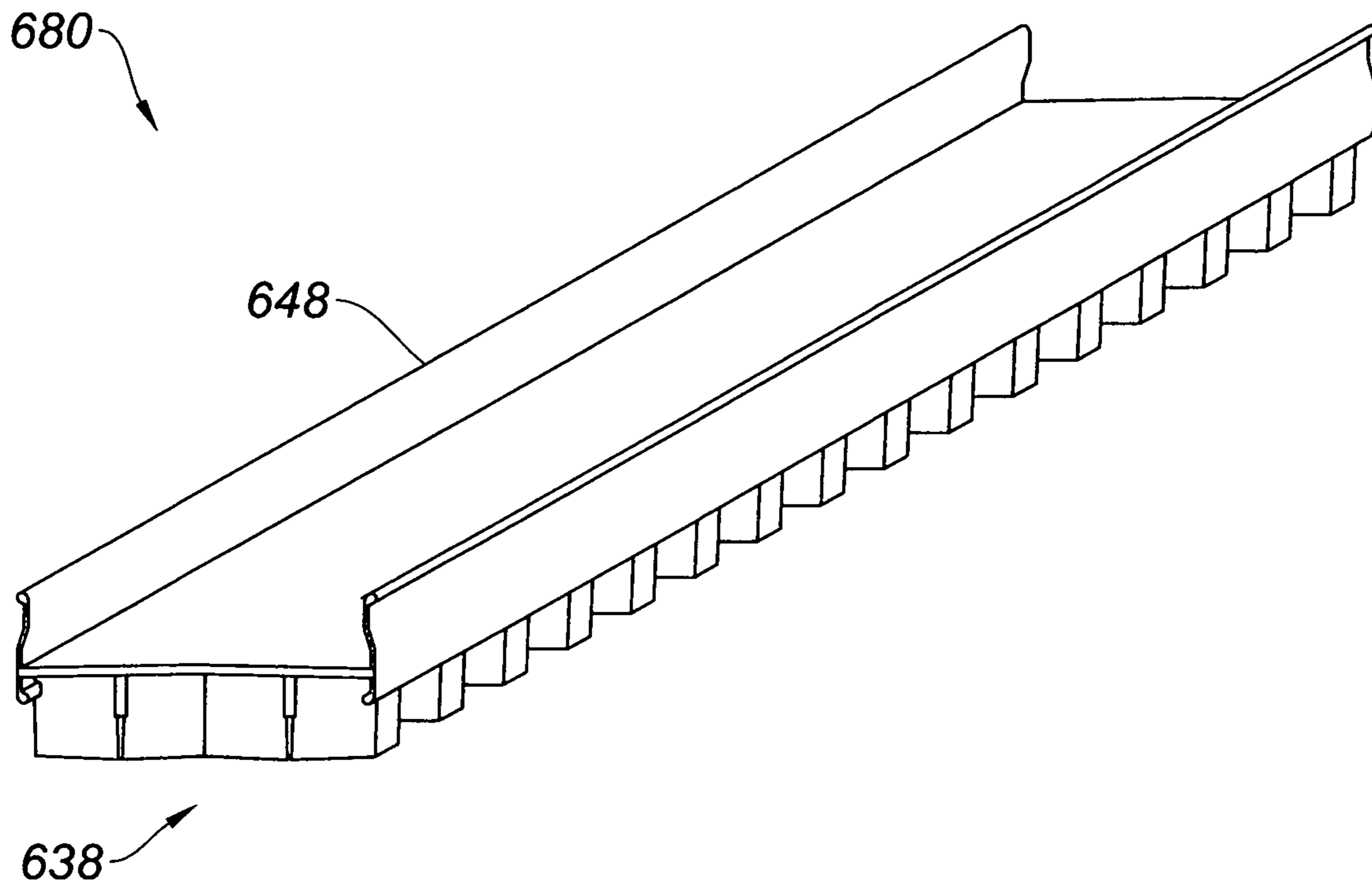

FIG. 6E

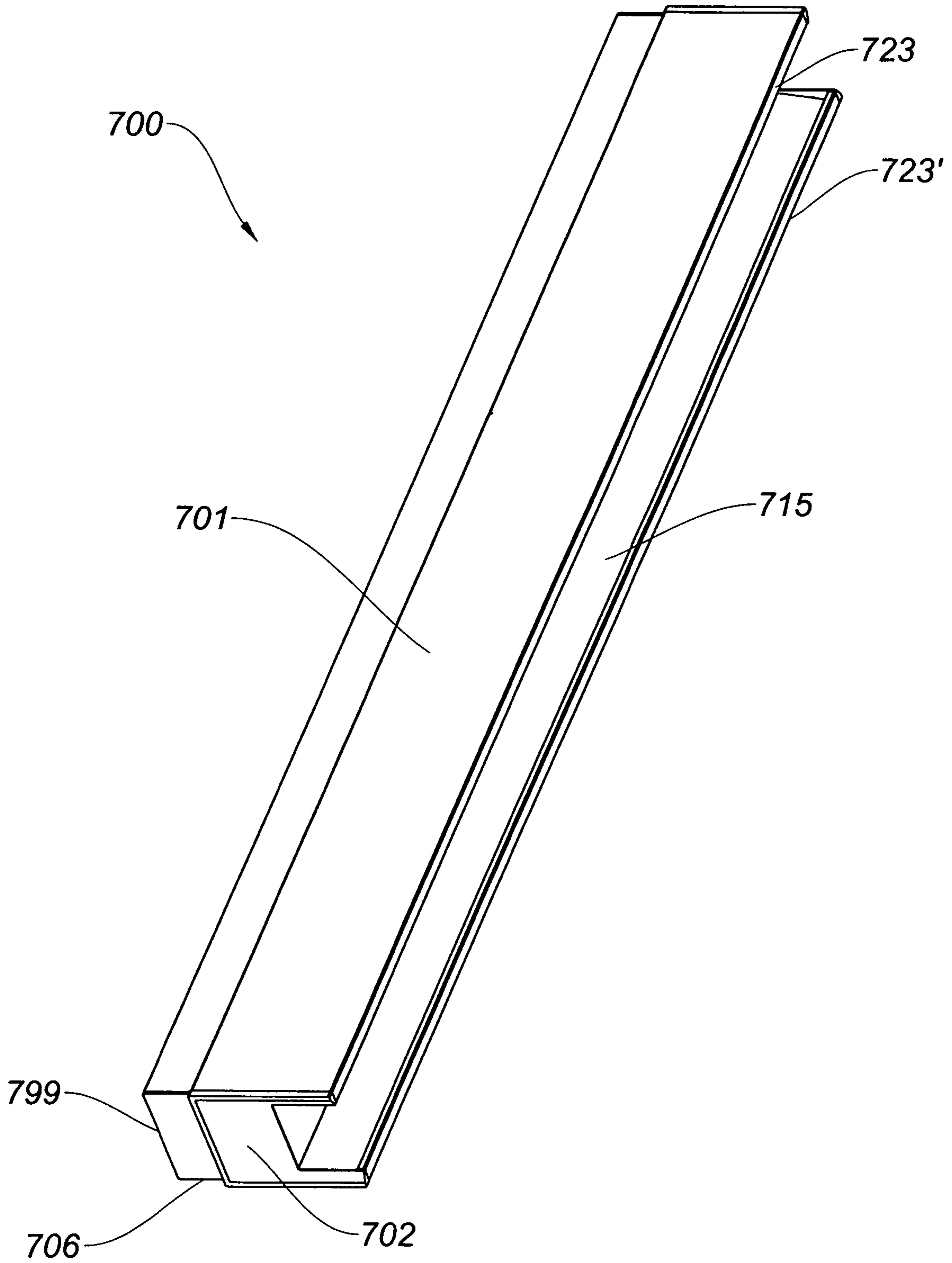

FIG. 7

**LED LIGHT FIXTURE FOR INDIRECT
LIGHTING WITH ADAPTABLE BAFFLE
STRUCTURE**

RELATED APPLICATION

This application is a continuation-in-part of the co-pending U.S. patent application Ser. No. 16/501,180 filed Mar. 1, 2019, and titled "OPEN CHANNEL LED LIGHT FIXTURE FOR INDIRECT LIGHTING," which claims priority under 35 U.S.C. § 119(e) from the U.S. provisional patent application Ser. No. 62/761,131, filed on Mar. 9, 2018, and titled "LIGHTING SYSTEM WITH LED ARRAYS." The co-pending U.S. patent application Ser. No. 16/501,180 filed Mar. 1, 2019, and titled "OPEN CHANNEL LED LIGHT FIXTURE FOR INDIRECT LIGHTING" and the U.S. provisional patent application Ser. No. 62/761,131, filed on Mar. 9, 2018, and titled "LIGHTING SYSTEM WITH LED ARRAYS" are both hereby incorporated by reference.

FIELD OF THE INVENTION

This invention relates to lighting systems. More specifically, this invention relates to Light Emitting Diode (LED) devices and systems.

BACKGROUND OF THE INVENTION

A light-emitting diode (LED) is a semiconductor diode that emits light when an electrical current is applied in the forward direction of the device, such as in a simple LED circuit.

The device is fabricated from layers of silicon and seeded with atoms of phosphorus, germanium, arsenic or other rare-earth elements. The layers of the device are called the die and the junction between the materials is where the light is generated. The electricity enters from one side of the die and exits out the other. As the current passes through the LED device, the materials that makes up the junction react and light is emitted.

LEDs are widely used as indicator lights on electronic devices and increasingly in higher power applications such as flashlights and area lighting. A LED is usually a small area (less than 1 mm²) light source, often with optics added to the chip to shape its radiation pattern and assist in reflection. The color of the emitted light depends on the composition and condition of the semiconducting material used, and can be infrared, visible, or ultraviolet. The glow, color and wash of a lighting fixture with sets of LED arrays is sensitive to the angles of the LED arrays with respect to one and other.

SUMMARY OF THE INVENTION

An LED light fixture of the present invention includes an elongated housing. Within the elongated housing, there is at least one extended or elongated open light cavity, hereafter lower light channel. The lower light channel has elongated inner side walls, elongated inner top walls and an elongated open bottom, hereafter referred to lower light channel side walls, top walls and open bottom. The lower light channel is contoured to have any number of shapes including, but not limited to, rectangular, triangular, angled, curved, rounded shapes or a combination thereof. In accordance with an embodiment of the invention, the elongated housing is formed from an extruded, molded or otherwise formed metal or plastic material. Preferably, the lower light channel is

formed from a contoured reflective metal or plastic reflective insert that fits within a lower portion of the elongated housing.

Near or at bottom portions of the side walls, and near the open bottom of the lower light channel, there are support edges that extend along the lower light channel and/or elongated housing. Positioned on top surfaces of the support edges, there are elongated light engines. The elongated light engines include LED arrays or LED strips that have light emitting surfaces facing upward for emitting light into the lower light channel.

In operation and with the LED arrays or LED strips energized, the LED arrays or LED strips emit light into the lower light channel and the light is reflected off wall surfaces and top surfaces of the lower light channel to emit indirect light out through the open bottom of the lower light channel.

In accordance with further embodiments of the present invention, an elongated LED light fixture provides upward and downward lighting. In accordance with this embodiment, the elongated LED light fixture has an upper light channel that is substantially similar to the lower light channel, such as described above, wherein an elongated housing of the light fixture has an H-shaped cross-section with an elongated electronics cavity or conduit positioned between the upper light channel and the lower light channel. The elongated electronics cavity or conduit is used for housing wiring, LED drivers and other control circuitry.

In accordance with further embodiments of the invention, the upper light channel has LED arrays or LED strips positioned on a top surface within the upper light channel. For example, the LED arrays or LED strips are centrally positioned on a top surface and within the upper light channel. The LED arrays, or LED strips position contained therein or on the top surface, can be angled and/or have symmetric or asymmetric diffusion lenses positioned over light emitting surfaces of the LED arrays or LED strips. It will be clear to one skilled in art that LED arrays and/or LED strips used in the light fixture of the present invention can be physically or optically configured to throw indirect and/or direct light having any number of preferred lighting patterns. Additional details of LED light fixtures with angled LED arrays and asymmetric lenses are provided in U.S. Pat. No. 10,024,522 B2, titled "LIGHT SYSTEM WITH ANGLED LED ARRAYS," the contents of which are hereby incorporated by reference.

In a preferred embodiment of the invention the LED light fixture includes a detachable cover structure with an H-shaped support feature. The H-shaped support feature has arms that are bridged by a diffusion lens. The detachable cover structure further includes a removable baffle. In operation, the arms of the H-shaped support feature have sets of snap features that attach to side walls of the upper light channel and matched groove features on the removable baffle. A LED light system of the present invention utilizing the LED light fixtures described above can be equipped with advanced control systems and/or control interfaces that allows for dimming and color temperature tuning. Control commands, operational protocols, or communication networks in the LED lighting system utilize and number of standards, including Digital Signal Interface (DSI) 0-10 V lighting control signals and formats, Digital Addressable Lighting Interface (DALI) lighting control signals and formats, DMX512 (Digital Multiplex) control signals and formats, or a combination thereof.

The LED lighting system, for example, includes a control unit coupled to one or more LED light fixtures for controlling power to the LED light fixtures based on control

command signals provided by any number of sensors, switches and control interface devices interface devices. A control unit includes, for example, a wireless transmitter for receiving and processing input control signals from a remote control interface device, such as a smart-phone or computer.

The LED arrays or LED strips (LED light engines) used in the lighting fixtures of the present invention can have any number of LEDs and can include LEDs that emit any color or combinations of colors and can be tunable to change color through the advanced control systems. Also, the light engines used in the light fixtures of the present invention can be mounted on modular light boards that are independently serviceable.

Advanced control systems, control interfaces and modular LED light boards are further described in U.S. Pat. No. 9,964,265 B2, titled "LIGHT EMITTING DIODE LUMINAIRE DEVICE AND SYSTEM WITH COLOR TEMPERATURE TUNING," the contents of which are hereby incorporated by reference.

BRIEF DESCRIPTION OF THE DRAWINGS

FIG. 1A shows a schematic representation an elongated LED light fixture with an elongated LED light board and LEDs positioned on top and bottom, or opposed sides, of the elongated LED light board to provide upward and downward lighting.

FIG. 1B-C show schematic representations of the elongated LED light board used in the light fixture shown in FIG. 1A.

FIG. 1D shows a cross-sectional view of the elongated LED light fixture shown in FIG. 1A.

FIG. 2 shows a cross-sectional view of an LED light fixture that provides indirect light from internal reflection of light emitted from a top surface of a centrally located LED light board within a light channel.

FIGS. 3A-C illustrate cross-sectional views of LED light fixtures with light engines mounted along side walls of an elongated light channel, in accordance with the embodiments of the invention.

FIG. 4A shows a cross-sectional view of an LED light fixture with an upper light channel and a lower light channel, each having light engines mounted along side walls, in accordance with the embodiments of the invention.

FIG. 4B shows a cross-sectional view of an LED light fixtures with an upper light channel and a lower light channel, wherein the lower light channel has light engines mounted along side walls of the lower light channel and centrally mounted light engine mounted on a top surface within the upper light channel.

FIGS. 5A-B show cross-sectional views of LED light fixtures with upper light channels and lower light channels, wherein the lower light channels have LED light engines mounted along side walls of the lower light channels having reflective inserts with centrally mounted LED light engines mounted within the upper light channels having a diffusion lens on or over light emitting surfaces of the centrally mounted light engines, in accordance with the embodiments of the invention.

FIG. 5C shows a cross-sectional view of an LED light fixture with an upper light channel and a lower light channel, wherein the lower light channel has LED light engines mounted along side walls of the lower light channel having a reflective insert, with a centrally mounted LED light engine mounted on a top surface and within the upper light channel and having a removable cover structure with a

diffusion lens and a detachable baffle structure, in accordance with the embodiments of the invention.

FIGS. 6A-B show a removable cover structure with a diffusion lens and a detachable baffle structure for attaching walls of an elongated light channel of a LED light fixture, in accordance with the embodiments of the invention.

FIG. 6C shows a front surface of the detachable baffle structure illustrated in FIGS. 6A-B.

FIGS. 6D-E show removable cover structure with a diffusion lens cover and with a detachable baffle structure with light wave guides for attaching to an elongated light channel of a LED light fixture, in accordance with the embodiments of the invention.

FIG. 7 shows a perspective view of an elongated LED light fixture, similar to the LED light fixture represented in FIG. 5C, with an elongated body having end cap covers and a removable cover structure, in accordance with the embodiments of the invention.

DETAILED DESCRIPTION OF THE INVENTION

Referring to FIGS. 1A-C, an elongated LED light fixture **100** has an elongated LED light board **103**. The elongated LED light board **103** is housed within elongated housing **101**. The elongated light fixture includes a bottom diffusion lens **105** and a top diffusion lens.

The elongated light board include arrays of LEDs **106** and **108** (upper array of LEDs and lower arrays of LEDs) on opposed sides of the elongated LED light board as shown. The individual LEDs **107**, **107'** and **107''** and **109**, **109'** and **109''** within the arrays of LEDs **106** and **108** can be the same or different.

FIG. 1D shows a cross-sectional view **150** of the elongated LED light fixture **100** shown in FIG. 1A. The elongated LED light fixture **150** has an upper light channel **115** and a lower light channel **115'**. The upper light channel **115** and a lower light channel **115'** are formed by the housing **101**. In operation, light that is emitted from the upper array of LEDs **106** and the lower array of LEDs **108** on the light board **103'**, as indicated by the arrows **111/111'** and **113/113'**, pass through the upper diffusion lens **105** and lower diffusion lens **105'** to provide upward and downward lighting, respectfully.

FIG. 2 shows a cross-sectional view **200** of an LED light fixture that provides what is herein referred to "indirect light" by internal reflection of light emitted from a top surface of a centrally located LED light board **203** positioned within the a light channel **215** of the LED light fixture. In operation, an LED array **206** mounted on the light board **203** emits light, indicated by the arrows **211** and **211'**, into the light channel **215** formed by a housing **201**. The emitted light **211** and **211'** is reflected off of inner surfaces **202** of the light channel **215** and is emitted through bottom portions **204** and **204'** of the light fixture. The bottom portions **204** and **204'** of the light fixture can be covered with diffusion lenses **205** and **205'**.

FIG. 3A illustrates cross-sectional view **300** of an LED light fixture, in accordance with the embodiments of the invention. The an LED light fixture has a rectangular elongated housing **301**. Within the rectangular elongated housing **301** there is at least one extended or elongated open light cavity **315**, hereafter lower light channel, open lower light channel or open lower light cavity. The lower light channel **315** has elongated inner side walls, and elongated inner top walls, represented by **302**, hereafter referred to inner surfaces and an open bottom **303**. The lower light channel **315**

5

is contoured to have any number of shapes and is preferably formed from an extruded, molded or otherwise formed metal or plastic material. The inner walls **302** of the lower light channel **315** are preferably reflective.

Near or at bottom portions of the inner walls **302** of the housing **301**, and near the open bottom **303** of the lower light channel **315** there are opposed support edges of structure **308** and **308'** that extend along the bottom portions of the inner walls **302** of the lower light channel **315** and/or elongated housing **301**. The support edges **308** and **308'** can have L-shaped cross-sections, be segmented, or continuous along the lower light channel **315** and/or elongated housing **301** and/or be symmetric or asymmetric in width or height.

Positioned on inner top surfaces of the support edges **308** and **308'** there are elongated LED light engines **305** and **305'** that have light emitting surfaces facing upward for emitting light into the lower light channel **315**, as indicated by the arrows **311** and **311'**. The light emitted **311** and **311'** emitted from the elongated LED light engines **305** and **305'** is reflected off the inner surfaces **302** of the elongated light channel **315**, as indicated by the arrows **313** and **313'**, and is emitted through the open bottom **303** of the lower light channel **315**.

FIG. 3B illustrates cross-sectional view **325** of an LED light fixture, in accordance with the embodiments of the invention. The LED light fixture has a triangular elongated housing **331** that forms a lower light channel **340** with inner walls **327** and an open bottom **328**.

Near or at bottom inner wall portions **325** and near the open bottom **328** of the lower light channel **340**, there are support edges **333** and **333'** that extend along the bottom inner wall portions **327** of the lower light channel **340** and/or elongated housing **331**.

Positioned on inner top surfaces of the support edges **333** and **333'** there are elongated LED light engines **335** and **335'** that have light emitting surfaces facing upward for emitting light into the lower light channel **340**, as indicated by the arrows **341** and **341'**. The light emitted **341** and **341'** emitted from the elongated LED light engines **335** and **335'** is reflected off the inner surfaces **327** of the elongated light channel **340**, as indicated by the arrows **343** and **343'**, and is emitted through the open bottom **328** of the lower light channel **340**.

FIG. 3C illustrates cross-sectional view **350** of an LED light fixture, in accordance with the embodiments of the invention. The an LED light fixture has a rounded elongated housing **351** that forms a lower light channel **365** with inner walls **352** and open bottom **353**.

Near or at bottom inner wall portions **352** and near the open bottom **353** of the lower light channel **365** there are support edges **358** and **358'** that extend along the bottom inner wall portions **352** of the lower light channel **365** and/or elongated housing **351**.

Positioned on inner top surfaces of the support edges **358** and **358'** there are elongated LED light engines **355** and **355'** that have light emitting surfaces facing upward for emitting light into the lower light channel **365**, as indicated by the arrows **361** and **361'**. The light emitted **361** and **361'** emitted from the elongated LED light engines **355** and **355'** is reflected off the inner surfaces **352** of the elongated light channel **365**, as indicated by the arrows **363** and **363'**, and is emitted through the open bottom **353** of the lower light channel **365**.

FIG. 4A illustrates cross-sectional view **400** of an LED light fixture, in accordance with further embodiments of the invention. The LED light fixture has an elongated housing **401** with an H-shaped cross-section that forms an upper light

6

channel **415** with an open top **403** and a lower light channel **415'** with an open bottom that are juxtaposed with respect to each other. While the upper light channel **415** and a lower light channel **415'** are shown to be rectangular, it will be clear for the previous examples that other shapes including, but not limited to, triangular, angled, curved, rounded shapes or combinations thereof are envisioned. Each of the upper light channel **415** and a lower light channel **415'** have reflective inner surfaces **402** and **402'** for reflecting light emitted therein. Between the inner walls **402'** and **402** of the upper light channel **415** and the lower light channel **415'**, there is an elongated electronics cavity or conduit **409** positioned for housing wiring, LED drivers and/or other control circuitry.

Near or at top portions of the inner walls **402** of the housing **401**, as well as the open top **403** of the upper light channel **415**, and at or near bottom portions of the inner walls **402'**, as well as the open bottom **403'**, there are support edges **404/404'** and **408/408'**, respectively, that extend along portions of the inner walls **402** and **402'** of the upper light channel **415** and the lower light channel **415'**, respectively.

Positioned on inner top surfaces of the support edges **404/404'** and **408/408'** there are elongated LED light engines **406/406'** and **405/405'** having light emitting surfaces facing inward for emitting light into the upper light channel **415** and lower light channel **415'**. The light emitted from the elongated LED light engines **406/406'** and **405/405'** is reflected off the inner surfaces **402** and **402'** of the upper light channel **415** and lower light channel **415'**, respectively, and is emitted through the open bottom open top **403** and open bottom **403'**.

FIG. 4B illustrates cross-sectional view **425** of an LED light fixture, in accordance with yet further embodiments of the invention. The LED light fixture has an elongated housing **431** with a truncated H-shaped cross-section that forms an upper light channel **440** with an open top and a lower light channel **440'** with an open bottom, wherein the upper light channel and the lower light channel are juxtaposed with respect to each other. Between the upper light channel **440** and the lower light channel **440'** there is an elongated electronics cavity or conduit **439** for housing wiring, LED drivers and/or other control circuitry.

Near or at bottom portions of the inner walls **427'** of the housing **431**, and near the open bottom of the lower light channel **440'** there are support edges **438** and **438'** that extend along portions of the inner walls **427'** of the lower light channel **440'**. In this example, the support edges **438** and **438'** are J-shaped and curving inward towards the lower light channel **440'**.

Positioned on inner top surfaces of the support edges **438** and **438'** are elongated LED light engines **435** and **435'**, having light emitting surfaces facing inward for emitting light into the lower light channel **440'**, such as described in detail above with reference to FIGS. 3A-C and FIG. 4.

Positioned between walls **442** and **442'** of the upper light channel **440** there is an elongated LED light engine **430** positioned on a top surface **427** within the upper light channel **440**. For example, elongated LED light engine **430** is centrally positioned on the top surface **427** within the upper light channel **440**. The LED light fixture has an asymmetric lens **443** positioned over light emitting surface of the elongated LED light engine **430** to throw light emitted from the elongated LED light engine **430** at an angle out from the open top of the upper light channel **440**.

FIG. 5A illustrates cross-sectional view **500** of an LED light fixture with an elongated housing **501** with a truncated

H-shaped cross-section that forms an upper light channel **515** with an open top and a lower light channel **515'** with an open bottom **503**.

Near or at bottom portions of walls of the lower light channel **515'** and edges of open bottom **503** of the lower light channel **515'** there are elongated support edges **523** and **523'** for supporting elongated LED light engines **505** and **505'** such as described above. In accordance with this embodiment of the invention, the LED light fixture includes an elongated reflective insert **502** that is formed from metal, plastic, paper or a composite of material. The elongated reflective insert **502** is contoured, angled, curved or any other suitable shape, and preferably extends the length of, or near the length of, the lower light channel **515'** within the elongated housing **501**. The elongated reflective insert **502** creates a reflection channel within the lower light channel. In operation, light is emitted from elongated LED light engines **505** and **505'** into the reflection channel formed by the elongated reflective insert **502** in the lower light channel **515'** and the emitted light is reflected off of the reflective insert **502** and emitted out through the open bottom **503** of the lower light channel **515'**.

Positioned between angled walls **522** and **522'** of the upper light channel **515**, there is an elongated LED light engine **524** positioned on a top surface within the upper light channel **515**. The elongated LED light engine **524** has sets or arrays of LEDs **518** and **518'** that extend along the length of the top surface of the upper light channel **515**. The sets or arrays of LEDs **518** and **518'** can be sets of liner arrays or strips of LED's or can be staggered arrays of LEDs. Positioned over light emitting surfaces of the sets or arrays of LEDs **518** and **518'**, there is a symmetric diffusion lens **521** for distributing light emitted out from the open top of the upper light channel **515**. Between the upper light channel **515** and the reflective insert **502** there is elongated electronics cavity or conduit **509** for housing wiring, LED drivers and/or other control circuitry.

FIG. 5B illustrates cross-sectional view **525** of an LED light fixture with an elongated housing **526** with a truncated H-shaped cross-section that forms an upper light channel **540** with an open top and a lower light channel **540'** with an open bottom **538**.

Near or at bottom portions of walls of the lower light channel **540'** and edges of open bottom **538** of the lower light channel **540'** there are elongated support edges **548** and **548'** for supporting elongated LED light engines **535** and **535'** such as described above. The LED light fixture includes an elongated reflective insert **532** that extends the length of, or near the length of, the lower light channel **540'** within the elongated housing **526**. Light that is emitted from elongated LED light engines **535** and **535'** is reflected off of the reflective insert **532** and emitted out through the open bottom **538**, such as described above.

Between angled or bat-wing shaped walls **542** and **542'** of the upper light channel **540** there is an elongated LED light engine **539** positioned within the upper light channel **540**. The elongated LED light engine **539** has sets or arrays of LEDs **528** and **528'**, such as described above. In this embodiment of the invention, there is bi-modal asymmetric diffusion lens **541** positioned over light emitting surface of the sets or arrays of LEDs **528** and **528'**. Between the upper light channel **540** and the reflective insert **532** there is elongated electronics cavity or conduit **539'** such as previously described.

FIG. 5C illustrates cross-sectional view **550** of an LED light fixture with an elongated housing **551** that forms an

upper light channel **565** with an open top and a lower light channel **565'** with an open bottom **553**.

Along bottom edges of open bottom **553**, there are support edges or structures **573** and **573'**, with elongated LED light engines **555** and **555'** configured to emit light into the lower light channel **565'** and such that the emitted light is reflected off of a reflective insert **552** and out of the open bottom **553**. The reflective insert preferably has a structure support **558** for supporting wiring, LED drivers and/or other control circuitry in an elongated electronics cavity or conduit **574** positioned between the upper light channel **565** and the support structure **558** of the reflective insert.

Between walls **572** and **572'** of the upper light channel **565** there is an elongated LED light engine **570** positioned within the upper light channel **565**. The light fixture **550** further includes a cover structure **599** that is positioned over the upper light cavity **565** and preferably fits into the groove features of the walls **572** and **572'** of the upper light channel **565**, thereby enclosing the upper light channel **565**.

The cover structure **599** includes an elongated H-shaped support feature **581** with a diffusion lens **555** positioned between the first set of snap features **574** and **574'**, that fit against the groove features of the walls **572** and **572'**, and a second set of snap features **557** and **557'**. The cover structure **599** also includes an elongated baffle structure **576** with fitted groove features **577** and **577'**, which fit against the second set of snap features **557** and **557'** of elongated H-shaped support feature **581**, as shown.

FIGS. 6A-B show schematic representations **600** and **625** of a disassembled and assembled cover structure **629**, respectively. The cover structure **629** includes an elongated H-shaped support feature **608** with a diffusion lens **607** positioned between arms of the elongated H-shaped support feature **608**. The arms of the elongated H-shaped support feature **608** include a first set of snap features **609** and **609'** and a second set of snap features **604** and **604'**. The cover structure **629** also includes a diffusion lens **607** that bridges the arms to form the H-shaped support feature **608** and a baffle structure **611**. The baffle structure can be sectionalized into regions **615**, **617** and **619** or patterned in any number of ways to create a desired lighting effect.

In operation, the baffle structure **611** is snapped into the H-shaped support feature **608**, such that the fitted grooves **618** and **618'** snap or fit into second set of snap features **604** and **604'**. The cover structure **629** can then be placed over a light channel **615** of an elongated light fixture **601** with a LED light engine **603** positioned therein. To place the cover structure **629** over the light channel **625** of the light fixture **601**, the first set of snap features **609** and **609'** are fitted or snapped into matched grooved or snap features **606** and **606'** on walls **605** and **605'** of the light fixture, as shown in FIG. 6B.

FIG. 6C illustrates a view **650** of a section of a bottom surface of a baffle structure **611'**. As described above, the baffle structure **611** can be sectionalized into regions **615'**, **617'** and **619'**, or can have any number of patterns or structures to generate a desired lighting effect.

FIGS. 6D-E show a cover structure with a H-shaped support feature with arms **648** and **648'** that are bridged by a diffusion lens **647** to form the H-shaped support feature. The arms **648** and **648'** have sets of snap features **639/640** and **639'/640'** such as described above. The snap features **640** and **640'** fit into matched groove features **649** and **649'** of a baffle structure **638**, such that the baffle structure **638** can be readily replaced or changed out with a different baffle structure. The depicted baffle structure includes a patterned structure **631**, which includes regions **635**, **637** and **639**, that

can be separated by light wave guides **641** and **643** that channel light to a bottom surface of the baffle structure **638**.

FIG. 7 shows a perspective view of an elongated LED light fixture **700**, similar to the LED light fixture represented in FIG. 5C. The elongated LED light fixture **700** includes an elongated housing **701** with end caps **702** that enclose an upper light channel with an elongated LED light engine and an electronics cavity or conduit with electronics, such as previously described in detail with respect to FIGS. 5A-C. The elongated LED light fixture **700** has an open bottom cavity **715** with a reflective insert for providing indirect lighting from internal reflection of light emitted from sets of elongated light engines **723** and **723'**. The elongated LED light fixture **700** also preferably includes a cover structure **706** that includes a H-shaped support feature with a diffusion lens and a removable baffle structure. Cover structures preferably snap in place over the upper light channel, such as illustrated with respect to FIG. 5C and FIG. 6B. In operation, cover structures enclose an elongated upper light channel such that light is emitted through the top surface **799** of the cover structure **706**.

The present invention has been described in terms of specific embodiments incorporating details to facilitate the understanding of the principles of construction and operation of the invention. As such, references herein to specific embodiments and details thereof are not intended to limit the scope of the claims appended hereto. It will be apparent to those skilled in the art that modifications can be made in the embodiments chosen for illustration without departing from the spirit and scope of the invention. For example, while the LED light fixture of the present invention has been shown herein to be elongated and linear, the LED light fixture can be curved, angled or have other shapes suitable for the application at hand.

What is claimed is:

1. A light fixture comprising:

- a) an elongated housing with a lower light channel with an open bottom and upper light channel juxtaposed to the lower light channel;
- b) opposed elongated support edges or structures positioned near bottom edges of the open bottom;
- c) elongated LED light engines positioned on the elongated support edges or structures and positioned near the bottom edges of the open bottom, wherein light emitted from the elongated LED light engines into the lower light channel is reflected out through the open bottom; and
- d) a detachable cover structure positioned over the upper light channel, wherein the detachable cover structure includes a H-shaped support feature with a diffusion lens and a removable baffle structure.

2. The light fixture of claim 1, wherein arms of the H-shaped support feature have sets of snap features that attach to side walls of the upper light channel and matched groove features on the removable baffle.

3. The light fixture of claim 1, further comprising an elongated light engine positioned on a top surface and within the upper light channel for emitting light therefrom.

4. The light fixture of claim 3, wherein the elongated light engine that is positioned on the top surface and within the upper light channel includes sets of linear arrays of LEDs.

5. The light fixture of claim 1, further comprising an elongated electronics cavity or conduit positioned between the lower light channel and the upper light channel.

6. The light fixture of claim 1, further comprising an elongated reflective insert that extends through the lower light channel and creates a reflection channel within the lower light channel.

7. A light fixture comprising:

- a) an elongated housing that forms an open lower light channel and an upper light channel that is juxtaposed to the open lower light channel with an electronics cavity or conduit positioned there between;
- b) elongated LED light engines positioned on support edges or structures within the open lower light channel for emitting indirect and reflected light out from the open lower light channel;
- c) an elongated LED light engine positioned within the upper light channel; and
- d) a detachable cover structure includes a H-shaped support feature with arms bridged by a diffusion lens and a removable baffle structure.

8. The light fixture of claim 7, wherein the arms of the H-shaped support attach to side walls of the upper light channel and to matched groove features on the removable baffle structure.

9. The light fixture of claim 7, further comprising an elongated reflective insert that extends through the open lower light channel and creates a reflection channel from which the indirect and reflected light is emitted.

10. A light fixture comprising:

- a) an elongated housing that forms an open lower light channel and an upper light channel that is juxtaposed to the open lower light channel;
- b) elongated LED light engines positioned on support edges or structures within the open lower light channel for emitting indirect and reflected light out from the open lower light channel;
- c) an elongated LED light engine positioned within the upper light channel;
- d) an elongated reflective insert that extends through the open lower light channel and creates a reflection channel from which the indirect and reflected light is emitted; and
- e) a detachable cover structure that includes a H-shaped support feature with arms bridged by a diffusion lens and a removable baffle structure, wherein the arms have sets of snap features that attach to side walls of the upper light channel and matched groove features on the removable baffle.

11. The light fixture of claim 10, wherein the elongated housing has an electronics cavity or conduit positioned between the open lower light channel and an upper light channel.

* * * * *