

J. M. BROWNING.
 FIREARM.
 APPLICATION FILED APR. 23, 1913.

1,070,582.

Patented Aug. 19, 1913.

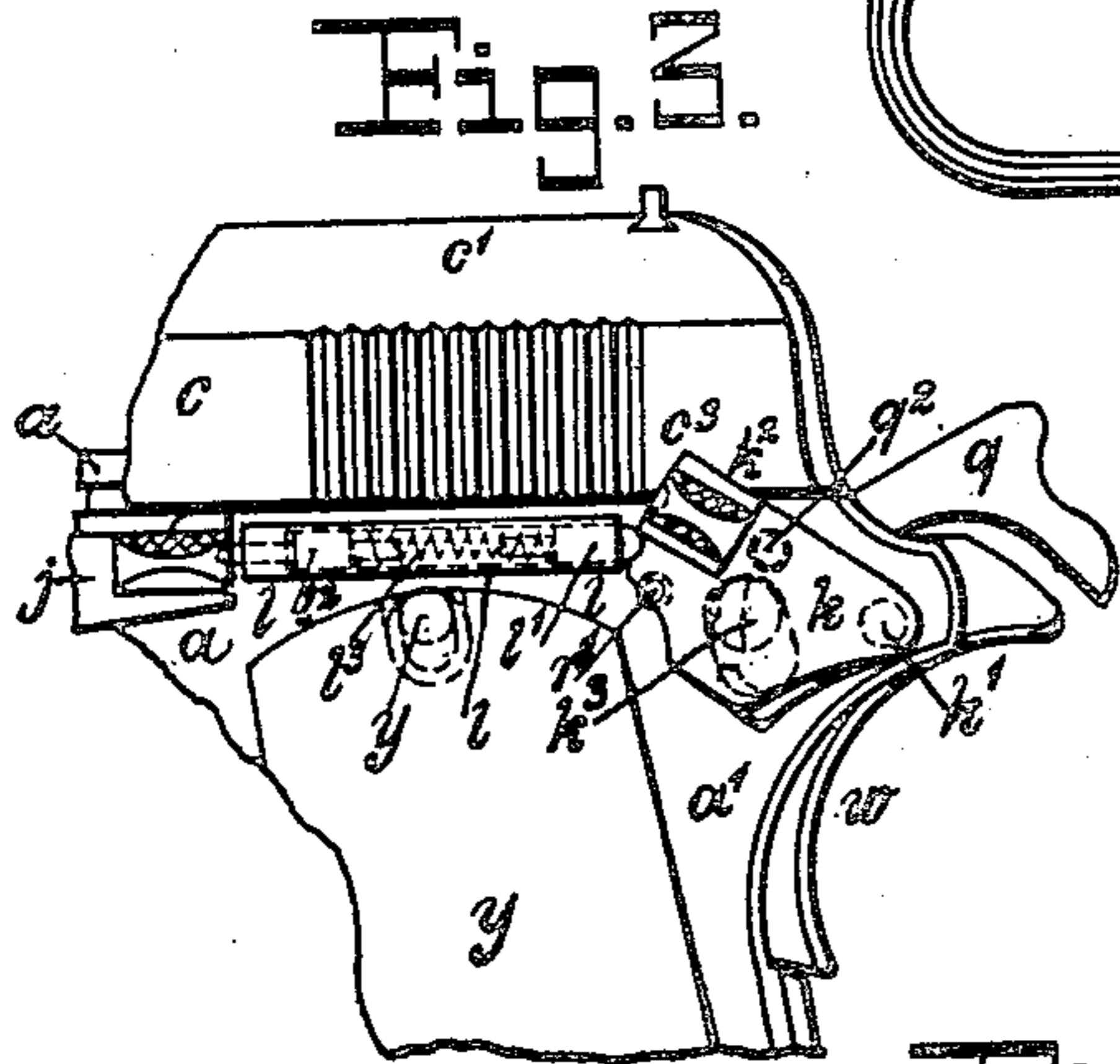
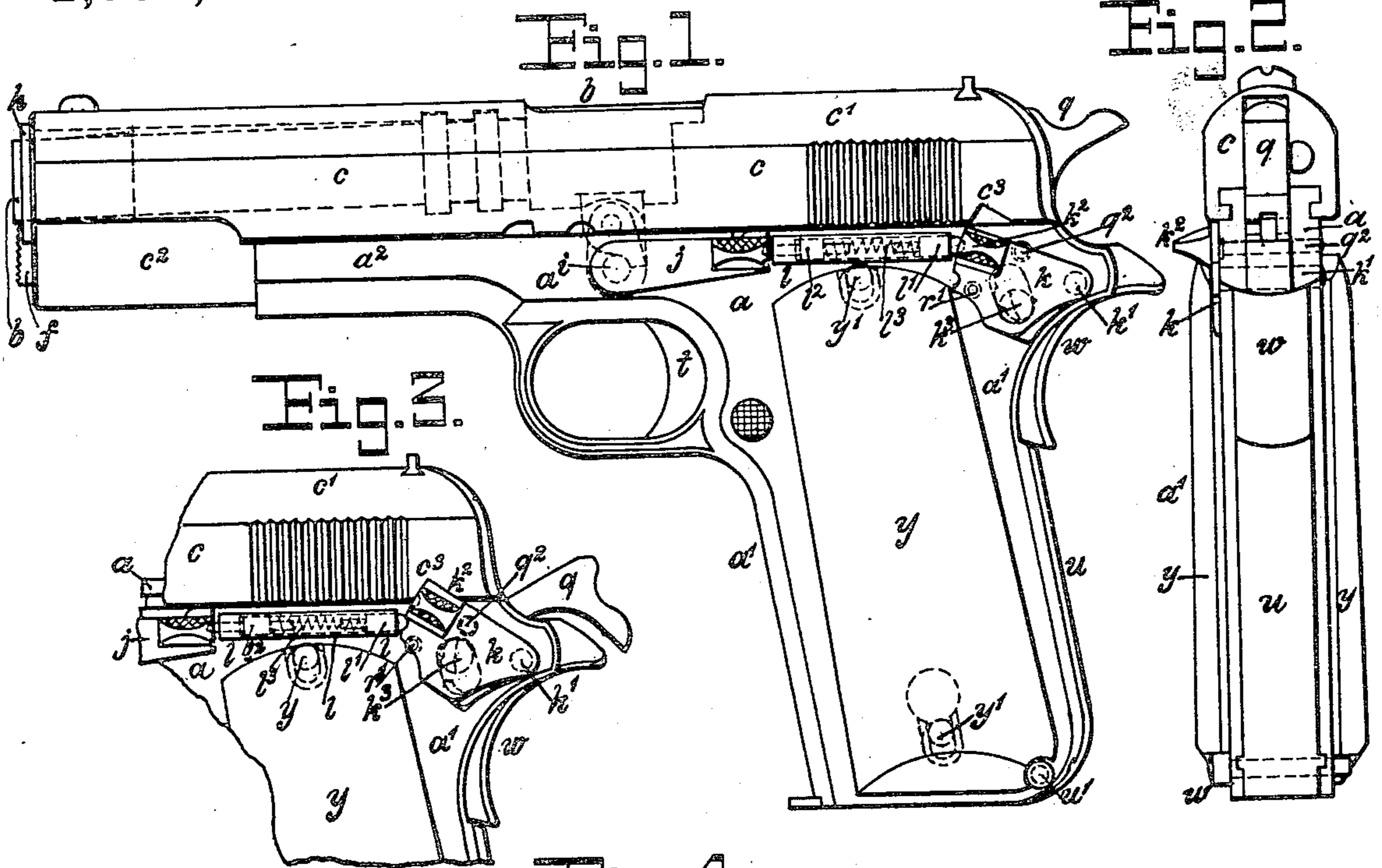

Fig. 3.

Fig. 4.

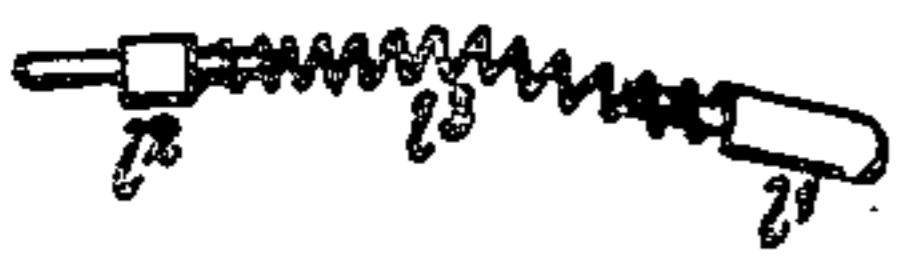
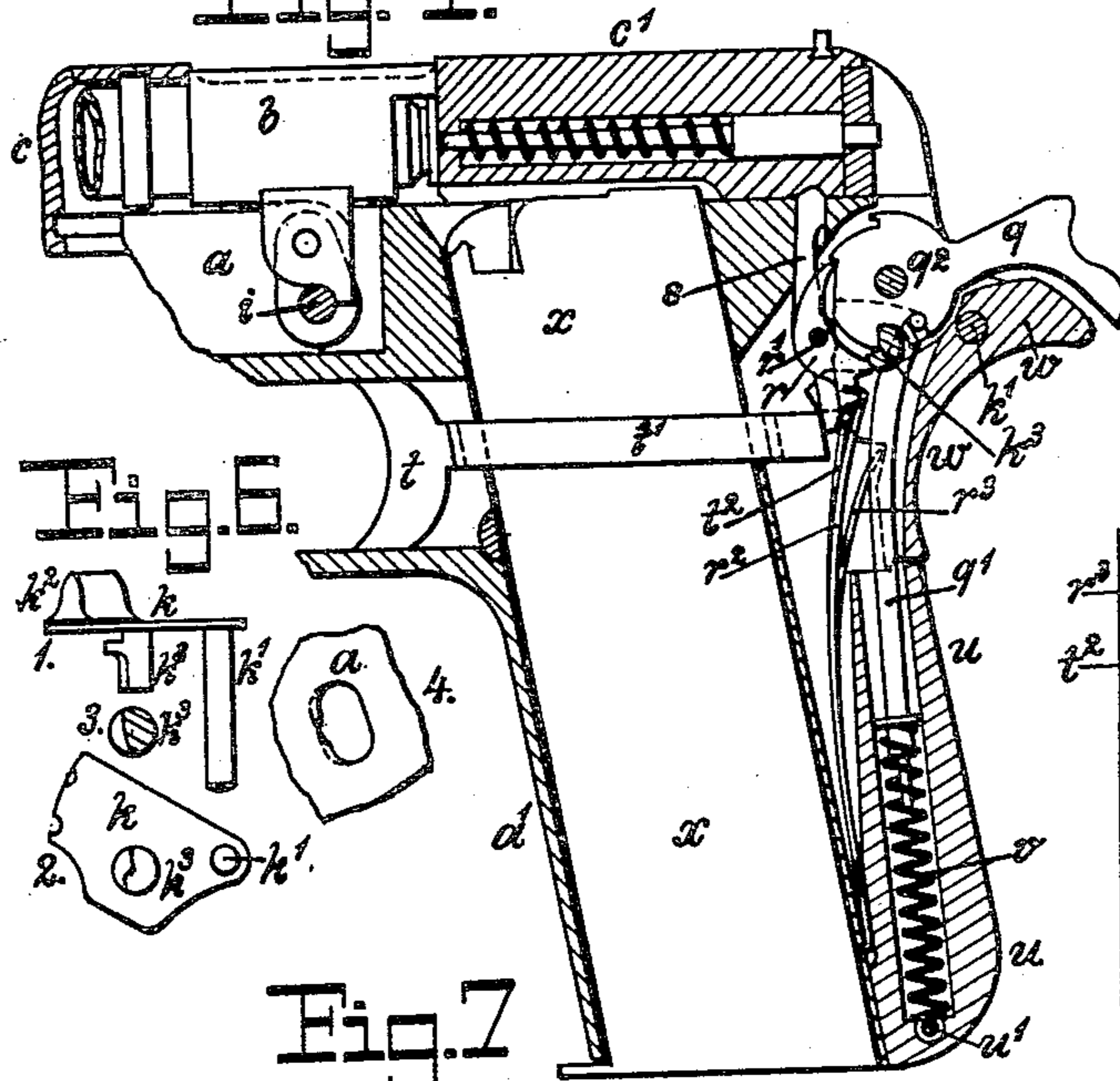

Fig. 5.

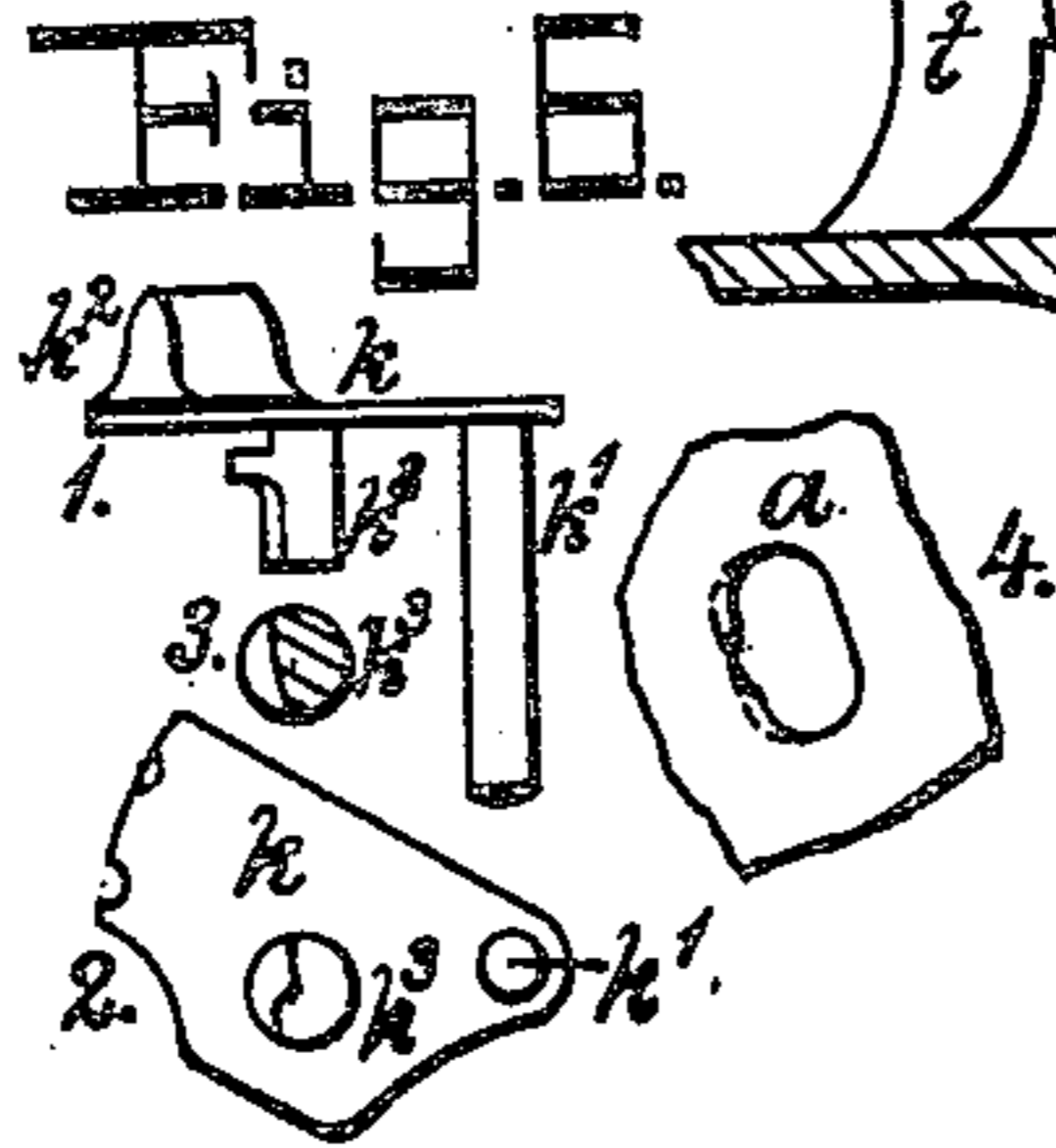
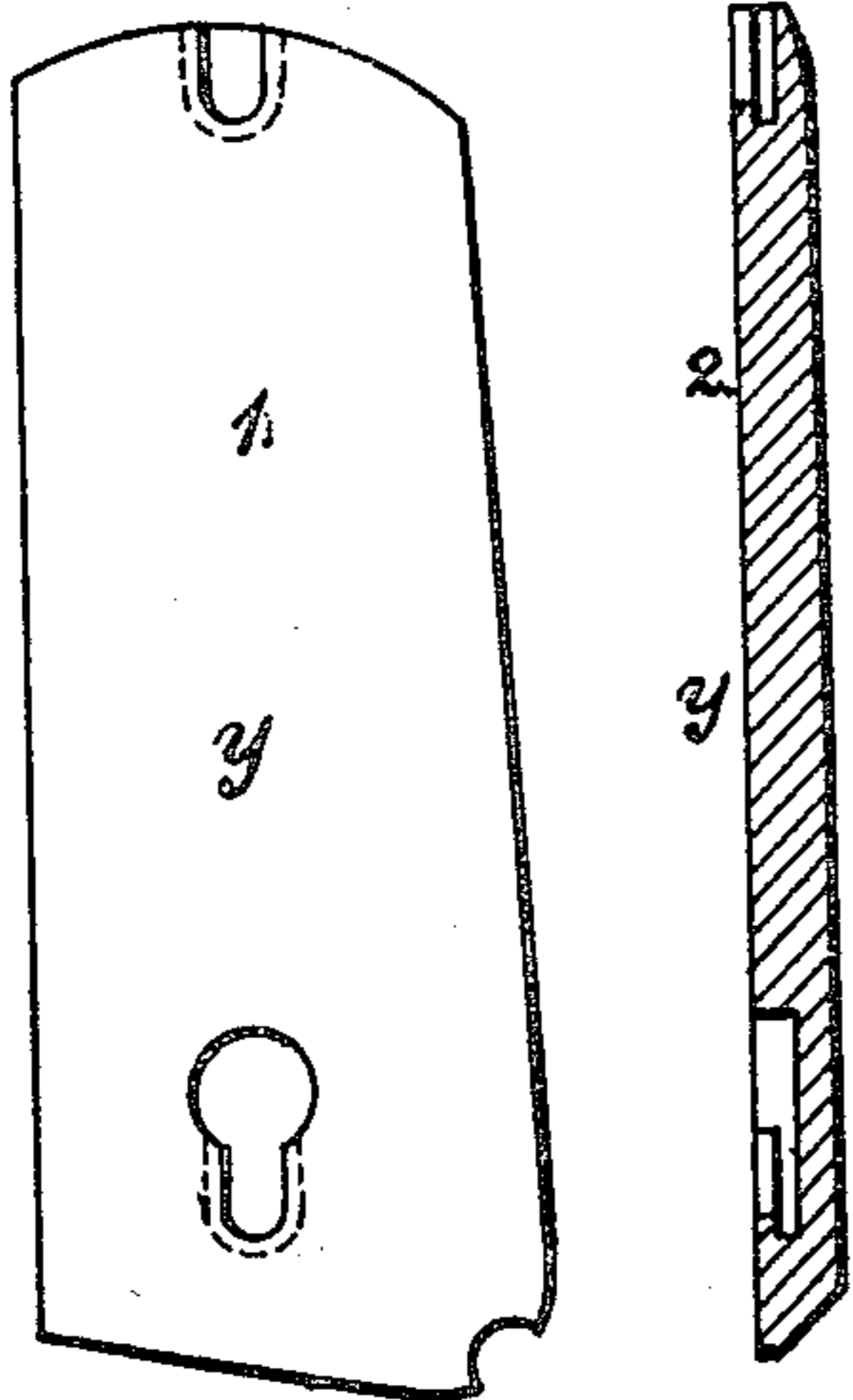

Fig. 6.

Fig. 7.

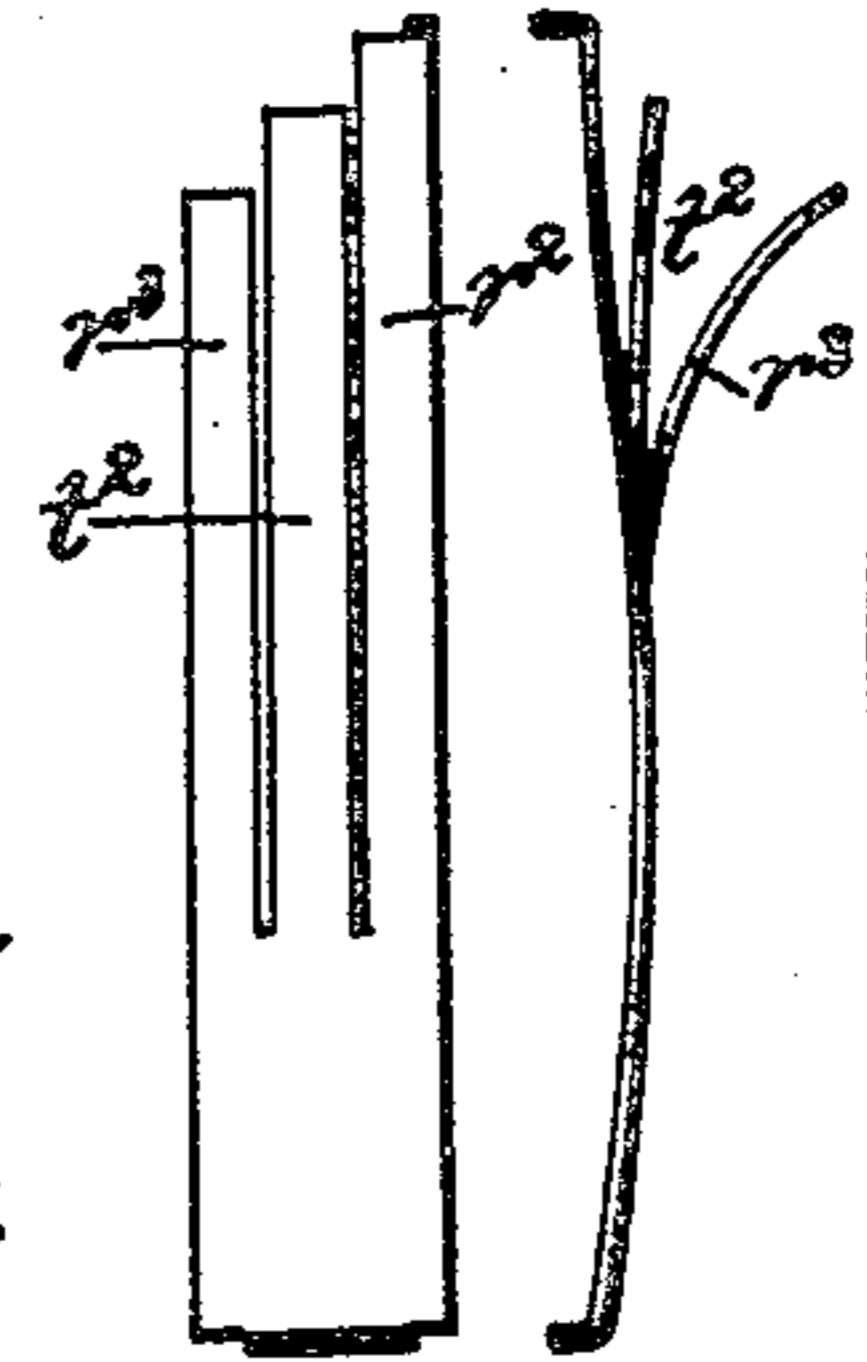
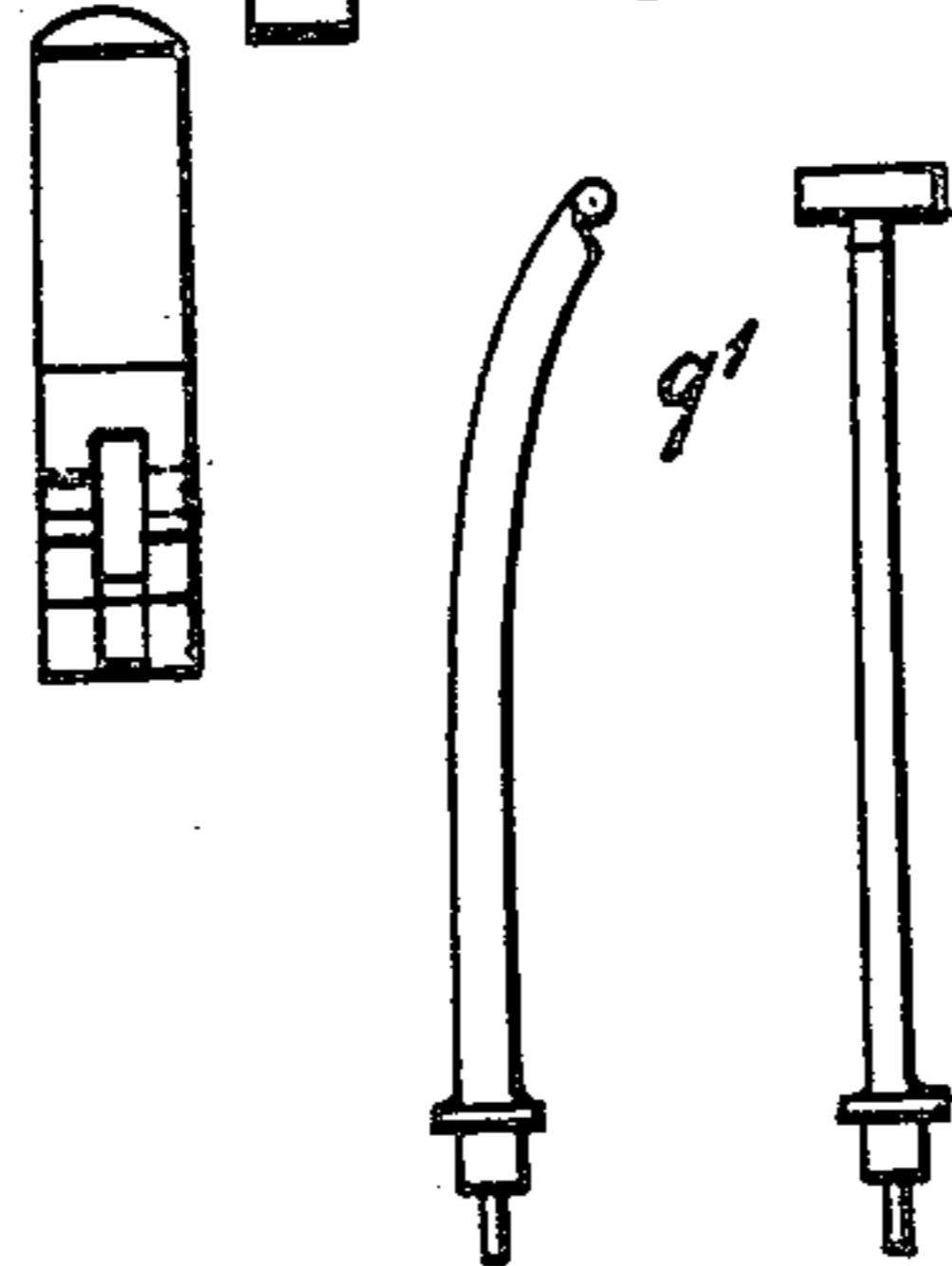
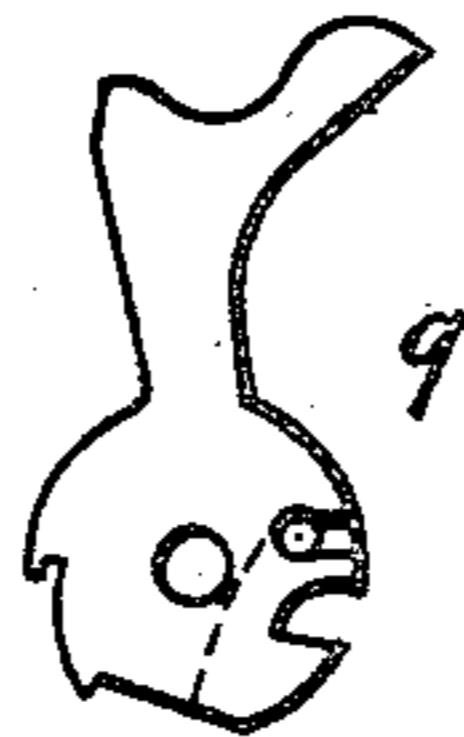
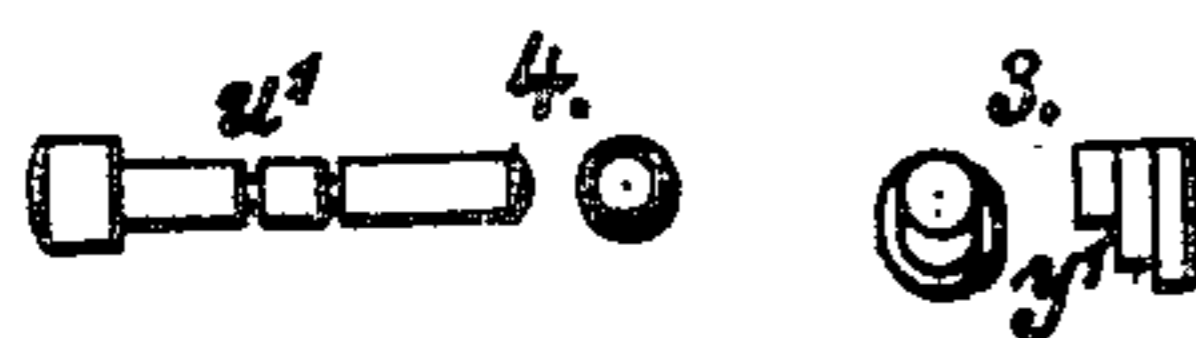

Fig. 8.



Witnesses.

W. Robinson
Wm. C. Skinner

Inventor.

John M. Browning,
by C. J. Ebbets,
Atty.

UNITED STATES PATENT OFFICE.

JOHN M. BROWNING, OF OGDEN, UTAH.

FIREARM.

1,070,582.

Specification of Letters Patent.

Patented Aug. 19, 1913.

Application filed April 23, 1913. Serial No. 763,045.

To all whom it may concern:

Be it known that I, JOHN M. BROWNING, a citizen of the United States, residing in Ogden, in the county of Weber and State of Utah, have invented certain new and useful Improvements in Firearms, of which the following is a specification, reference being had to the accompanying drawings, forming a part hereof.

10 The invention relates generally to automatic firearms of that description in which all operations, except the actuation of the trigger for firing, are automatically effected by the energy of the recoil of the breech-closing part.

15 The invention particularly relates to novel improvements in firearms of the class described in the United States Patent No. 984,519, granted to me February 14, 1911, said patent covering many of the features of the complete firearm which I have herein described and illustrated with the object of enabling my present invention and the objects thereof to be understood. These features which are common to the two constructions are referred to herein only as far as is necessary to explain the present invention, but the description which follows relates particularly to the novel improved features of this case.

20 The main object of the present invention is to produce an improved firearm of this class specially adapted for the military service by being reliable, accurate, strong and absolutely safe under all conditions, while simple in construction, not liable to get out of order and inexpensive of manufacture. This object is attained by simplifying the mechanism of the arm, by providing an improved construction of certain parts thereof, thereby enabling each of these parts to perform several distinct functions, and thus reducing the number of the component parts, and by giving to all the parts such form that they may be put in place or removed and the entire arm may be assembled or dismounted without requiring the use of any tools.

25 The embodiment of my improvements represented in the accompanying drawings is a magazine pistol, such as is shown and described in my said Patent No. 948,519; but it will be understood that I do not intend to restrict the present invention to a magazine

pistol, nor to any particular kind of firearm, nor to the combination of the several features in a single firearm.

In the accompanying drawings: Figure 1, is a left-hand side elevation of the pistol with the breech-slide closed and the hammer at rest, not cocked. Fig. 2, is a rear end view of the pistol. Fig. 3, is a view similar to Fig. 1, of the upper rear portion of the pistol, but with the closed breech-slide locked and the hammer cocked and locked. Fig. 4, is a longitudinal vertical section of the rear portion of the pistol showing the firing mechanism and the safety mechanisms, the breech-slide being closed and the hammer cocked and locked. Fig. 5, represents one of the side-plates of the pistol grip detached, and one of the studs and the locking pin detached, by which the side-plates are removably attached to the grip; 1 being a view of the inner side and 2 a longitudinal vertical section of the side-plate, 3 a side view and an end view of the stud, and 4 a side view and end view of the locking-pin. Fig. 6, represents the combined slide-lock and hammer-lock detached, 1 being an edge view seen from below, 2 an inner side view of the slide-lock, 3 a cross section of the integral locking-stud thereon, on a line parallel to and just beneath the plate-like body of the lock, and 4 a side view of a portion of the left side of the pistol frame, showing the aperture therein for the entrance of the stud, and the undercut front edge for securing the stud in the frame. Fig. 7, represents a side view and a rear view of the hammer detached, and a side view and rear view of the hammer-strut detached. Fig. 8, represents the two pistons and the spiral spring, detached, by which the pivot-pin-handle and the slide-lock and hammer-lock are yieldingly held in place. Fig. 9, represents a side view and a front view of the combined trigger and safety-spring, sear-spring, and grip-lever-spring, detached.

Similar letters refer to similar parts throughout the several views.

The pistol represented in the drawings has three main parts, the frame *a*, the barrel *b* mounted upon the frame, and the breech-slide *c*, which slides rearward and forward upon the frame under the action of the recoil and of the reaction-spring. The frame extends downward in form of the handle or grip

5 a^1 , and in the grip is the seat for the detachable cartridge magazine x of usual construction, in which cartridges are held one above the other upon a spring-follower by which they are fed upward to the receiver. In front of the grip the trigger t is located in the trigger-guard, while the hammer q and other members of the firing mechanism and safety mechanisms are arranged in rear of the grip.

10 The barrel b is attached at its rear end to the frame by a link pivoted in a depending lug of the barrel, the lower part of the link being attached to the frame by the pivot-pin i fitted transversely through the frame and the link, thus securing link and barrel movably to the frame.

20 The rear part of the breech-slide c forms the breech-bolt c^1 and forward thereof the breech-slide forms an integral extension, which incloses the barrel and carries at its forward end a bushing h for keeping the muzzle of the barrel in place. The forward portion of the breech-slide c is closed at the bottom by a depending smaller tube extending some distance to the rear and forming the abutment c^2 with its axis parallel to the breech-slide and its front closed by the plug f . From the abutment c^2 rearward the sides of the breech-slide overlap the sides of the frame, and are provided with integral lengthwise grooves and ribs interlocking with corresponding ribs and grooves in the sides of the frame by which the breech-slide is vertically secured upon the frame and guided in its movements thereon.

30 At its front the frame a has the extension a^2 for receiving the abutment c^2 of the breech-slide, which moves therein when the breech-slide recoils upon the frame. In the extension a^2 of the frame and the abutment c^2 of the breech-slide the spiral reaction-spring is arranged as usual, exerting its tension against the plug f to yieldingly hold the breech-slide in its forward position in which the breech-bolt c^1 closes the breech of the barrel.

40 The pivot-pin i projects from the left side of the frame where it carries the rearwardly extending handle j resting against the side of the frame, by which the removal of the pivot-pin i and thereby the release for removal of the barrel and breech-slide in forward direction from the frame are effected.

50 The breech-bolt c^1 carries a firing-pin and an extractor of usual form, and the hammer q , sear r and safety s are pivotally mounted in the frame, so that when released by the operation of the trigger t , while the breech-slide is in the forward position, the hammer will strike the firing-pin which transmits the blow to the primer of the cartridge.

60 The rear of the grip is closed by the butt-piece u sliding from below into the grip,

and secured therein by the pin w^1 fitted transversely through the grip and butt-piece; within the butt-piece u the spiral main-spring v is seated, the strut q^1 pivotally attached to the hammer q transmitting the tension of the main-spring v to the hammer.

70 In front of the butt-piece u the trigger- and safety-spring t^2 , the sear-spring r^2 and the grip-lever-spring r^3 are seated. In rear of the hammer q and above the butt-piece u the grip-lever w is secured in the grip by the pivot-pin k^1 , and the grip-lever-spring r^3 yieldingly holds the grip-lever w in its rear position in which a forward projection of the grip-lever stands in rear of the connecting piece t^1 of the trigger and locks the trigger against operation, while the lower portion of the grip-lever w projects from the rear of the grip. When the grip is grasped, as in the act of firing, the grip-lever is pressed into the grip, thereby automatically releasing the trigger for operation without requiring attention.

80 All the parts thus far referred to may be and are here shown as of the same construction and mode of operation as fully set forth in my said Patent No. 984,519, and forming no part of the present invention require no further description or explanation herein, except so far as certain features will be referred to hereinafter.

90 Heretofore pistols of this class were provided with automatic safety devices which made it impossible to fire one or several shots unless a cartridge was in the barrel, a charged magazine in the grip and all parts were in the proper closed and locked condition, the hammer cocked and the grip properly grasped to hold the pistol in the firing position. If, with the pistol thus made ready for instant use, the occasion for firing or for continued firing had passed, and it was desired to make the pistol temporarily safe for carrying, it was necessary to lower the hammer to the safety position, and special means were provided for enabling the lowering of the hammer to be performed, if necessary, by the use of only the hand holding the pistol. Experience, however, has shown that the exigencies of active military service make it at times necessary that the pistol be carried for a longer or shorter time with a loaded cartridge in the barrel, a charged magazine in its seat and with the hammer cocked, so as to still remain ready for instantly firing a maximum number of shots without requiring any initial movement, except the pulling of the trigger. At the same time, it is as necessary that the pistol can be made safe to positively prevent its accidental discharge while being so carried. For fulfilling, as nearly as possible, these necessary but contradictory requirements, an additional manually op-

70

75

80

85

90

95

100

105

110

115

120

125

130

erated combined slide-lock and hammer-lock of novel construction and with additional functions has been provided on the pistol, which serves to at will lock the breech-slide and the firing mechanism and make the pistol positively safe against discharge though a cartridge is in the chamber and the hammer is cocked, or to at will release these parts and make the pistol ready for firing; with this added device the locking or releasing of the slide and of the hammer require only a slight pressure by the thumb of the hand grasping the grip of the pistol, without demanding such attention, care and exertion as are required for cocking the hammer or for releasing and lowering the same.

The combined slide-lock and hammer-lock consists of the plate-like body k pivotally secured upon the left side of the frame in rear of the grip by its integral pivot-pin k^1 which passes transversely through the frame and through the grip-lever w , thus serving also to pivotally secure the grip-lever in the frame. Above the plate k an angular recess c^3 has been cut in the lower edge of the breech-slide which corresponds with the forward upper corner of the plate k and stands above the same when the breech-slide is in the forward closed position, so that the plate k may be turned upward upon its pivot to enter the recess c^3 and thereby to positively lock the breech-slide in the forward closed position. By its location the plate k is just above and within easy reach of the thumb of the hand grasping the grip of the piston, and upon the outside at the upper forward corner of the plate a lateral projection k^2 provides a thumb piece by which the plate k may be at will turned upward into its operative slide-locking position, or downward into the releasing position by applying a slight pressure with the thumb in the desired direction, without requiring more than the slightest attention or effort.

From the inner surface of the slide-lock or plate k a stud k^3 extends through an opening in the left side of the frame inward to a position in rear of the lower arm of the sear r and below the hub of the hammer q , see Figs. 1, 3 and 4. The stud k^3 is cylindrical, except at its free inner end, where for some distance a segment has been cut away from its forward side. With the slide-lock in its lower inoperative position, as in Fig. 1, the cut-away portion of the stud k^3 keeps the same clear of the path of the sear and of the hammer, both of which are thus free for operation; but when the slide-lock is raised to lock the slide, as in Fig. 3, the stud k^3 is thereby moved to the rear of the lower arm of the sear, positively preventing the same from being operated to release the cocked hammer, Fig. 4. A recess is provided in the hub of the hammer into

which a portion of the stud k^3 enters when in the raised position, see Fig. 4, thereby the hammer is locked independently of its support by the sear, so that even under violent blows against the exposed part of the hammer, which might break the point of the sear, the hammer cannot move. When the hammer is down, not cocked, the recess in its hub not being above the stud k^3 , the slide-lock cannot be raised to the locking position until the hammer is again cocked.

In Fig. 6 at 4 is shown the shape of the aperture in the left side of the frame through which the stud k^3 is entered into the frame when the slide-lock is being placed in position; this aperture is elongated to permit the necessary upward and downward movements of the stud and of the slide-lock for locking or releasing the slide and the hammer, but the aperture is covered by the slide-lock in both positions. The central part of the aperture is wider than the upper and lower parts, a segmental recess centrally in the forward edge of the aperture being provided for allowing the cylindrical portion of the stud k^3 to pass into the frame. Above and below this recess in the forward edge of the aperture, the side wall of the frame is undercut and reduced in thickness, as is indicated by dotted lines in Figs. 1, 3 and 6, to correspond in thickness with the groove cut in the front side of the cylindrical portion of the stud k^3 , just beneath the plate or slide-lock k , see Fig. 6 at 1 and 3. The undercut forward edge of the aperture and the bottom of the groove in the stud being formed concentric to the pivot k^1 of the slide-lock k , they interlock and movably secure the slide-lock in the frame in all positions except when the slide-lock is midway between its upper and lower positions, in this central position only the slide-lock may be removed from the frame the stud k^3 then passing out through the central recess in the edge of the aperture. As the integral pivot-pin k^1 of the slide-lock is the pivot on which the grip-lever w is mounted in the frame, the securing in place of the slide-lock also secures the grip-lever in place, and by the removal of the slide-lock the grip-lever also is released for removal from the frame. Moreover, the pivot-pin q^2 of the hammer and the pivot-pin r^1 of the sear and safety are fitted to enter into the frame from the left side toward the right side, and each pin has a head of slightly larger diameter on its left end, so that they can be removed from the frame only by being pushed from the right toward the left side thereof. With the slide-lock k in its place it covers both of these pivot pins q^2 and r^1 , thus securing them in the frame, and on the removal of the slide-lock these pivot-pins may be readily pushed out and thereby the hammer q , sear r and safety s are released for

removal from the frame without the use of any tool.

In order to keep the slide-lock k in either the raised or the lowered position, a spring-actuated piston l^1 is provided, the rounded point of which bears against the forward edge of the slide-lock k , and enters one of the two shallow recesses in said edge corresponding with the point of the piston in each of the positions of the slide-lock, and serving to yieldingly hold the slide-lock in either position to which it may be moved. The piston l^1 and the spiral spring l^3 pressing it rearward, are seated in a small horizontal tube l attached to the left side of the frame above the grip, in front of the slide-lock k , so that the slightly protruding point of the piston l^1 may enter the recesses, see Figs. 1 and 3.

As heretofore constructed and shown and described in my said prior patent, the handle j of the pivot-pin i was provided with a small spring-pressed piston seated in the hollow rear portion of the handle, and held therein for limited movement by a transverse pin, the protruding point of the piston bearing against a small rounded stud fixed in the side of the frame, thereby holding the handle yieldingly in either of the positions to which it may be moved. In the present improved construction the spring, piston and locking-pin in the handle j and the stud on the frame have been eliminated, and the rear end of the imperforate handle j , provided with two shallow recesses, is located in front of the forward end of the tube l . In this end of the tube l a second small piston l^2 is seated, and the spiral spring l^3 in the tube tends to press the rounded point of this piston l^2 forward into contact with the handle j , so as to yieldingly hold the same in position, Figs. 1 and 3. The forward end of the piston l^2 is reduced in diameter forming a shoulder on the piston which bears against a corresponding shoulder in the inner bore of the tube l near its forward end, by this arrangement the forward piston l^2 is prevented from being thrown forward from the tube when the pivot-pin i and the handle j are detached from the frame. The pistons l^1 and l^2 are each reduced in diameter in their inner portions nearest to the spiral spring l^3 which fits upon these reduced parts, and the exterior diameter of the spring l^3 is small enough to freely move in the tube l ; to prevent the pistons l^1 and l^2 and the spring l^3 from being thrown rearwardly from the tube l when the slide-lock k is removed, the spring l^3 is bent at the center of its length so that its forward and rearward halves form an obtuse angle instead of being in a straight line, see Fig. 8. When the spring l^3 and the two pistons l^1 and l^2 are together fully inserted into the tube l , with

the reduced part of each piston seated in one of the ends of the spring, the tension of the spring lengthwise will hold the pistons yieldingly with their points protruding from the tube l , because the pistons, fitting loosely in the tube, guide the ends of the spring therein and keep them from contact with the tube; whereas the bent center of the spring is pressed by the tension of the same against the inside of the tube and causes at that point sufficient friction to yieldingly hold spring and pistons in the tube, but to allow them to be at will drawn from the rear of the tube. By this arrangement, therefore, these parts are held in place without requiring the usual locking-pin, and it allows their ready assemblage and removal without requiring the use of any tools.

All parts of the safety mechanisms and of the firing mechanism mounted in the rear part of the frame have thus been shown to be held securely therein by the slide-lock k when in its place, while they become readily removable by the removal of the slide-lock. An accidental release and displacement of the slide-lock itself is prevented by the arrangement under which it can be removed only at one point, midway between its lower and its raised position, because, while it requires but a slight effort to fully raise or lower the slide-lock, it being yieldingly held in either of these positions, it requires considerable care and effort to move it to and hold it in the central position and there to withdraw it laterally from the frame; there being nothing to arrest the slide-lock except at the proper limits of its movements, a casual stopping midway between these limits will not occur, because the pressure of the spring-actuated piston l^1 against the front edge of the slide-lock tends to cause it to complete its vertical movements, and also tends to prevent any lateral movement of the slide-lock away from the side of the frame.

While the spiral main-spring v is seated within the butt-piece u , like that shown and described in my said prior patent, the upper and lower pistons at the ends of the main-spring and the small transverse pin for securing them in the butt-piece, have been eliminated by the present construction. The lower end of the seat of the spring in the butt piece allows the lowest coil of the main-spring to partly project into the hole which passes transversely through the sides of the grip and through the butt-piece at the lower end of the same, in which the pin w^1 is fitted which secures the butt-piece in the grip of the pistol, Figs. 1, 2 and 4. As is shown in Figs. 4 and 5, the pin w^1 has two annular grooves into which the lowest coil of the main-spring partly enters, so that the spring itself yieldingly holds the pin w^1 in its place in the grip. Both ends

of the pin u^1 project laterally from the grip and the pin may be readily removed by pressure upon its right end.

The strut q^1 is pivotally connected with the hammer, but instead of being attached thereto, as heretofore, by a separate pivot-pin, the strut q^1 carries at its upper end integral trunnions which fit into the pivot-holes in the hammer, see Figs. 4 and 7, and through the left side of the divided rear part of the hammer a slot is cut from the pivot-hole rearward, through which the trunnions of the strut may be entered into their seats in the hammer, the strut being guided in a radial direction from the rear toward the same until the trunnions enter the holes, then turning the strut on the trunnions downward until it enters the central vertical slot in the hammer, the trunnions are locked in their seats and the strut is secured to the hammer, see Fig. 4, thus dispensing with the separate pivot-pin, and with the use of tools which were required for driving out the pivot-pin for the removal of the strut, whereas the strut, as here represented, may be as readily detached from the hammer by raising it to the radial position, without requiring the use of tools. Near the lower end the strut q^1 has a collar and below the same a part which fits into the main-spring, so that, when in place, the spring bears against the collar and the strut directly transmits the tension from the main-spring to the hammer. Below the part fitting into the main-spring, the end of the strut q^1 has been given the form of a punch of small diameter. This part may be used in dismounting the pistol, after the pin u^1 , the butt-piece u , the slide-lock k , the grip-lever w and the hammer-strut q^1 have been removed in the manner hereinbefore explained, the small end of the strut may serve to release the hammer, sear and safety for removal by pushing their pivot-pins out of the frame.

As shown in Figs. 4 and 9, the trigger and safety-spring t^2 , the sear-spring r^2 and the grip-lever-spring r^3 are formed as separate leaves, but are integral by being combined at their lower ends into one common body, which having at its end a forward projection fitting into a transverse slot in the rear wall of the magazine-seat in the grip, is secured therein endwise or vertically, while the front of the butt-piece u , when in place, securely locks the spring against rearward displacement. The sear-spring r^2 is provided at the upper end and on the outer part of its width with a forward projection by which the correct introduction and location of the combined springs in the grip is insured, there being no room for the placing of this forward projection except at the left side of the lower part of the sear.

As seen in Figs. 1 and 5, the side-plates

of the grip are secured to the frame by two studs y^1 , one of which is represented detached in Fig. 5 at 3, two of the studs are firmly attached by their shouldered ends in each side of the frame, one at the top and the other near the bottom of the side-plates y , where each stud forms a lateral projection provided with a larger T-shaped downwardly projecting head. Each side-plate y has in its inner face a circular recess for the reception of the lower stud, and, extending downward from the recess, a T-shaped slot corresponding to the head and neck of the stud. In the upper end of each side-plate y a similar T-shaped slot is cut for the upper stud. To attach the side-plate to the grip, it is placed on the side of the grip slightly below its normal position, with the lower stud in the lower recess and the upper stud just above the upper slot, then the side-plate is pushed upward so that the two studs will enter the slots, and firmly lock the side-plate to the grip of the frame. At the lower rear corner each side-plate has a partly circular recess for the reception of the projecting portion of the locking-pin u^1 , by driving this pin into its place both side-plates are positively locked to the grip. For removing the side-plates the pin u^1 is removed, then each side-plate may be readily moved downward to be thereby released from the studs, when it may be removed from the grip.

It will be evident that various features of this invention may be employed independently of the rest, and in fire-arms of a different kind from that which I have described herein, and that various changes in form and arrangement of the parts may be made without departing from the spirit of the invention.

What I claim, and desire to secure by Letters Patent, is:

1. In a firearm, the combination of a frame, a breech-slide sliding on the frame, a firing mechanism mounted in said frame, a grip-lever pivoted in said frame and having an extension to lock or release said firing mechanism, and a slide-lock pivotally mounted on said frame for engaging or releasing a shoulder on said breech-slide for locking said slide in its forward position and releasing same, said slide-lock having an integral pivot-pin fitted transversely through said frame and through said grip-lever, whereby said slide-lock is pivoted in said frame and pivotally secures said grip-lever in said frame.

2. In a firearm, the combination of a frame, a breech-slide sliding on the frame, a firing mechanism comprising a hammer and a sear pivoted in said frame, a grip-lever pivoted in said frame and having an extension to lock or release said firing mechanism, and a slide-lock pivotally mounted on said

frame for engaging or releasing a shoulder on said breech-slide for locking said slide in its forward position and releasing same, said slide-lock having an integral pivot-pin fitted transversely through said frame and through said grip-lever whereby said slide-lock is pivoted in said frame and pivotally secures said grip-lever in said frame, said slide-lock also having an inward projection extending into the frame for locking the hammer in its cocked position.

3. In a firearm, the combination of a frame, a breech-slide sliding on the frame, firing mechanism comprising a hammer and a sear pivoted in said frame, a grip-lever pivoted in said frame and having an extension to lock or release said firing mechanism, and a slide-lock pivotally mounted on said frame for engaging or releasing a shoulder on said breech-slide for locking said slide in its forward position and releasing same, said slide-lock having an integral pivot-pin fitted transversely through said frame and through said grip-lever whereby said slide-lock is pivoted in said frame and pivotally secures said grip-lever in said frame, said slide-lock also having an inward projection extending into the frame for locking the sear when it holds the hammer in cocked position.

4. In a firearm, the combination of a frame, a breech-slide sliding on the frame, firing mechanism comprising a hammer and a sear pivoted in said frame, a grip-lever pivoted in said frame and having an extension to lock or release said firing mechanism, and a slide-lock pivotally mounted on said frame for engaging or releasing a shoulder on said breech-slide for locking said slide in its forward position and releasing same, said slide-lock having an integral pivot-pin fitted transversely through said frame and through said grip-lever, whereby said slide-lock is pivoted in said frame and pivotally secures said grip-lever in said frame, said slide-lock also having an inward projection extending into the frame for locking the hammer in its cocked position and for locking the sear against releasing said hammer.

5. In a firearm, the combination of a frame, a breech-slide sliding on the frame, firing mechanism comprising a hammer and a sear pivoted in said frame, a slide-lock pivotally mounted on said frame for engaging or releasing a shoulder on said breech-slide for locking said slide in its forward position and releasing the same, said slide-lock having an inward projection extending into the frame for engaging and locking the hammer in its cocked position and for engaging and locking the sear against releasing said hammer.

6. In a firearm, the combination of a frame, a breech-slide sliding on the frame,

firing mechanism secured in said frame by pivot-pins, and a slide-lock pivoted on said frame having a shoulder for engaging said breech-slide to lock it in its forward position and having a plate-like body to cover and secure in place the pivot-pins of said firing mechanism.

7. In a firearm, the combination of a frame, a breech-slide sliding on the frame, firing mechanism comprising a hammer and a sear secured in said frame by pivot-pins fitted transversely through said frame and held therein in one direction by having heads of increased diameter, and a slide-lock pivoted on said frame having a shoulder for engaging said breech-slide to lock it in its forward position, and having a plate-like body to cover said heads and secure in place the pivot-pins of said firing mechanism.

8. In a firearm, the combination of a frame, a breech-slide sliding on the frame, firing mechanism secured in said frame by pivot-pins, and a slide-lock pivotally mounted on said frame having a shoulder for engaging said breech-slide to lock it in its forward position, and having a plate-like body to cover and secure in place the pivot-pins of said firing mechanism and also having an inward projection extending into the frame for locking the firing mechanism in cocked position when the said slide-lock is moved into position to lock the slide.

9. In a firearm, the combination of a frame, a breech-slide sliding on the frame, firing mechanism secured in said frame by pivot-pins, a grip-lever pivoted in said frame and having an extension to lock or release said firing mechanism, and a slide-lock pivotally mounted on said frame having a shoulder for engaging said breech-slide to lock it in its forward position, and having an integral pivot-pin fitted transversely through said frame and through said grip-lever, and also having a plate-like body to cover and secure in place the pivot-pins of said firing mechanism.

10. In a firearm, the combination of a frame, a breech-slide sliding on the frame, firing mechanism secured in said frame by pivot-pins, and a slide-lock pivotally mounted on said frame having a shoulder for engaging said breech-slide to lock it in its forward position, and having a plate-like body to cover and secure in place the pivot-pins of said firing mechanism, and also having an inward projection extending into the frame for locking the firing mechanism in cocked position, said projection having a recessed portion for interlocking with the frame whereby said slide-lock is movably secured on said frame.

11. In a firearm, the combination of a frame, a breech-slide sliding on the frame, firing mechanism secured in said frame by

5 pivot-pins, and a slide-lock pivotally
 10 mounted on said frame having a shoulder
 for engaging said breech-slide to lock it in
 its forward position, and having a plate-like
 15 body to cover and secure in place the pivot-
 pins of said firing mechanism, and having
 also an inward projection extending into
 the frame for locking the firing mechanism
 in cocked position, said projection having a
 20 recessed portion for interlocking with the
 frame, and said frame having an elongated
 aperture widened at its central part, where-
 by said projection may be inserted or re-
 25 moved from said aperture at its central part
 when the slide-lock is in an intermediate
 position, and the recessed portion in said in-
 ward projection interlocks with the frame
 when said slide-lock is in its locking position
 or in its unlocked position.

20 12. In a firearm, the combination of a
 frame, a breech-slide sliding on the frame,
 firing mechanism secured in said frame by
 pivot-pins, and a slide-lock pivotally mount-
 25 ed on said frame having a shoulder for en-
 gaging said breech-slide to lock it in its
 forward position, and having a plate-like
 body to cover and secure in place the pivot-
 pins of said firing mechanism, and having
 30 also an inward projection extending into
 the frame for locking the firing mechanism
 in cocked position, said projection having
 a recessed portion for interlocking with the
 frame, and said frame having an elongated
 35 aperture widened at its central part, where-
 by said projection may be inserted or re-
 moved from said aperture at its central part
 when the slide-lock is in an intermediate
 position, and the recessed portion in said in-
 40 ward projection interlocks with the frame
 when said slide-lock is in its locking posi-
 tion, or in its unlocked position, and a
 spring-pressed member engaging the slide-
 lock for yieldingly holding it in locked or
 unlocked position.

45 13. In a firearm, the combination of a
 frame, a member pivoted on said frame so
 as to be movable to one position or another,
 a second member pivoted on said frame so
 as to be movable to one position or another,
 50 a tube-like inclosure on the frame located
 between said two members, a spring in said
 inclosure with a piston at each end for
 yieldingly engaging said members and hold-
 ing them in either position.

55 14. In a firearm, the combination of a
 frame, a member pivoted on said frame so
 as to be movable to one position or another,
 a second member pivoted on said frame so as
 to be movable to one position or another,
 60 a tube-like inclosure on the frame located
 between the two members, a spring in said
 inclosure with a piston at each end for
 yieldingly engaging said members, said
 spring having a bend in the portion between
 65 the pistons so as to frictionally engage the

wall of the inclosure and hold the spring in
 position in the inclosure while the two ends
 of the spring are guided by the pistons so
 as to operate freely and independently.

70 15. In a firearm, the combination of a
 frame, a member pivoted on said frame so
 as to be movable to one position or another,
 a second member pivoted on said frame so
 as to be movable to one position or another,
 75 a tube-like inclosure on the frame located
 between said two members, a spring in said
 inclosure with a piston at each end for
 yieldingly engaging said members, one of
 said pistons having a shoulder engaging a
 80 projecting portion in the inclosure to con-
 fine the spring and pistons in the inclosure
 at one end, said spring and pistons being
 confined at the other end by engagement
 with one of said members.

85 16. In a firearm, the combination of a
 frame, a breech-slide sliding on said frame,
 firing mechanism mounted in said frame, a
 barrel connected to said frame by a pivot-
 pin, a rearwardly projecting handle for said
 pivot-pin, a slide-lock pivotally mounted on
 90 said frame, a tube-like inclosure on the
 frame located between said handle and said
 slide-lock, a spring in said inclosure with a
 piston at each end for yieldingly engaging
 said handle and said slide-lock.

95 17. In a firearm, the combination of a
 frame, a breech-slide sliding on said frame,
 firing mechanism secured in said frame by
 pivot-pins, a member pivoted on said frame,
 a slide-lock pivoted on said frame having a
 100 plate-like body for covering and securing in
 place the pivot-pins of the firing mechanism
 and having an inward projection for remov-
 ably securing it to the frame, a tube-like
 inclosure on said frame located between
 105 said member and said slide-lock, and a
 spring in said inclosure with a piston at
 each end for yieldingly engaging said mem-
 ber and said slide-lock.

110 18. In a firearm, the combination of a
 frame, a breech-slide sliding on said frame,
 firing mechanism secured in said frame by
 pivot-pins, a member pivoted on said frame,
 a slide-lock pivoted on said frame, having
 a plate-like body for covering and securing
 115 in place the pivot-pins of the firing me-
 chanism and having an inward projection for
 removably securing it to the frame and for
 locking the firing mechanism in cocked po-
 sition, and a tube-like inclosure on said
 120 frame located between said member and said
 slide-lock, and a spring in said inclosure
 with a piston at each end for yieldingly en-
 gaging said member and said slide-lock.

125 19. In a firearm, the combination of a
 frame, a hammer, a butt-piece, a pin for re-
 movably securing said butt-piece in said
 frame, grooves in said pin, a coiled main-
 spring carried in the butt-piece and having
 130 its lowest coil entering the grooves in said

pin so as to yieldingly secure the pin in place, and a strut between the upper end of said main-spring and the hammer.

20. In a firearm, the combination of a frame, a butt-piece removably secured in said frame, a main-spring carried in the butt-piece, a strut having trunnions at its upper end and connected at its lower end with said main-spring, a hammer having at its rear portion two vertical walls separated by a space, pivot-holes in said walls for said trunnions and a slot in one of the walls extending from one of the pivot-holes whereby the trunnions may be entered in the pivot-holes and the strut between the walls when the strut is in line with the slot, and the strut confined between the walls with the trunnions in the pivot-holes when the strut is turned downward toward operative position.

21. In a firearm, the combination of a frame, a butt-piece removably secured in said frame, a main-spring carried in the butt-piece, a strut having at its lower end a collar resting on top of the main-spring and a projection entering into said main-spring, said strut having trunnions at its upper end, a hammer having at its rear portion two vertical walls separated by a space, pivot-holes in said walls for said trunnions and a slot in one of the walls extending from one of the pivot-holes whereby the trunnions may be entered into the pivot-holes and the strut between the walls when the strut is in line with the slot, and the strut confined between the walls with the trunnions in the pivot-holes when the strut is turned downward toward operative position.

22. In a firearm, the combination of a frame, a hammer, a sear, a trigger, a grip-lever, a spring for the sear, a spring for the trigger and a spring for the grip-lever, said three springs being formed as separate leaves at their upper ends and merging into a common integral body at their lower ends, said body having near its lower end a transverse projection and said frame having a slot to receive said projection, whereby the three springs are lengthwise and laterally kept in position in the frame.

23. In a firearm, the combination of a frame, a hammer, a sear, a trigger, a grip-lever, a spring for the sear, a spring for the trigger and a spring for the grip-lever, said three springs being formed as separate

leaves at their upper ends and merging into a common integral body at their lower ends, one of said spring-leaves having a forward projection at its upper end, and a space in the frame for receiving said forward projection.

24. In a firearm, the combination of a frame having a grip, a side-plate for the grip, T-shaped slots in the side-plate extending downwardly from suitable openings in said side-plate, studs on the frame having T-shaped heads for entering said openings and engaging said slots, and a pin extending through and from the frame and yieldingly held therein for engaging the said side-plate and securing it in position on the frame with said heads engaged with said slots.

25. In a firearm, the combination of a frame having a grip, a side-plate on each side of the grip, a T-shaped slot in the top of each side-plate, and a T-shaped slot extending downward from a suitable opening near the bottom in each side-plate, studs on the frame having T-shaped heads for entering and engaging said slots, and a pin extending through and projecting from the sides of the frame and yieldingly held therein for engaging and securing both side-plates in position on the grip with said heads engaged with said slots.

26. In a firearm, the combination of a frame having a grip, a butt-piece removably seated in the grip and a coiled main-spring carried in said butt-piece, a side-plate for each side of the grip, a T-shaped slot in the top of each side-plate, and a T-shaped slot extending downward from a suitable opening near the bottom of each side-plate, studs on the frame having T-shaped heads for entering and engaging said slots, and a pin extending through the grip and the butt-piece for securing said butt-piece in said grip and projecting from the sides of said grip for engaging and securing both side-plates in position on the grip with said heads engaging said slots, said pin having grooves for the entrance of the lowest coil of said main-spring, whereby said pin is yieldingly held in place by the main-spring.

This specification signed and witnessed this 14th day of April A. D. 1913.

JOHN M. BROWNING.

In the presence of—
MATTHEW GALT,
H. O. WILLIAMS.