

US010704259B2

(12) **United States Patent**  
**Kim**

(10) **Patent No.:** **US 10,704,259 B2**  
(45) **Date of Patent:** **Jul. 7, 2020**

(54) **GONGPO ASSEMBLY STRUCTURE OF TRADITIONAL KOREAN-STYLE HOUSE AND TEMPLE**

(58) **Field of Classification Search**  
CPC . E04B 7/04; E04B 7/02; E04B 1/2604; E04D 1/30; E04D 1/3405  
See application file for complete search history.

(71) Applicant: **Jin Woo Kim**, Gangwon-do (KR)

(56) **References Cited**

(72) Inventor: **Jin Woo Kim**, Gangwon-do (KR)

U.S. PATENT DOCUMENTS

(\*) Notice: Subject to any disclaimer, the term of this patent is extended or adjusted under 35 U.S.C. 154(b) by 0 days.

1,425,107 A \* 8/1922 Levinson ..... A63F 9/12  
273/160  
1,763,748 A \* 6/1930 Best ..... F16B 12/48  
211/196

(Continued)

(21) Appl. No.: **16/076,623**

FOREIGN PATENT DOCUMENTS

(22) PCT Filed: **Feb. 22, 2017**

JP H01310036 A 12/1989  
KR 200363394 Y1 9/2004

(86) PCT No.: **PCT/KR2017/001944**

(Continued)

§ 371 (c)(1),  
(2) Date: **Aug. 8, 2018**

OTHER PUBLICATIONS

(87) PCT Pub. No.: **WO2017/146460**  
PCT Pub. Date: **Aug. 31, 2017**

International Search Report; dated Jun. 1, 2017 for PCT Application No. PCT/KR2017/001944.

(65) **Prior Publication Data**  
US 2019/0048586 A1 Feb. 14, 2019

*Primary Examiner* — Paola Agudelo  
(74) *Attorney, Agent, or Firm* — Mendelson Dunleavy, P.C.

(30) **Foreign Application Priority Data**

Feb. 23, 2016 (KR) ..... 10-2016-0021327  
Dec. 22, 2016 (KR) ..... 10-2016-0177115  
Feb. 22, 2017 (KR) ..... 10-2017-0023537

(57) **ABSTRACT**

The present invention relates to a gongpo assembly structure of a traditional Korean-style house and temple, the gongpo assembly structure including: at least one gongpo fixing member provided with an interlocking slot formed in a shape depressed toward lower and inward directions from an surface thereof, and laid one upon another by being fastened to the fixed object; a judu provided with a wide open groove formed on a center of a top surface thereof and an interlocking protrusion formed on one side wall thereof and interlocked with the interlocking slot of the gongpo fixing member; and a gongpo provided with an interlocking slot and interlocking protrusion, and assembled with a top of the judu. Accordingly, the gongpo may be standardized and mass-produced at a factory, thereby allowing a general

(Continued)

(51) **Int. Cl.**  
**E04B 7/04** (2006.01)  
**E04B 7/02** (2006.01)  
(Continued)

(52) **U.S. Cl.**  
CPC ..... **E04B 7/04** (2013.01); **E04B 1/2604** (2013.01); **E04B 7/02** (2013.01); **E04D 1/30** (2013.01);  
(Continued)

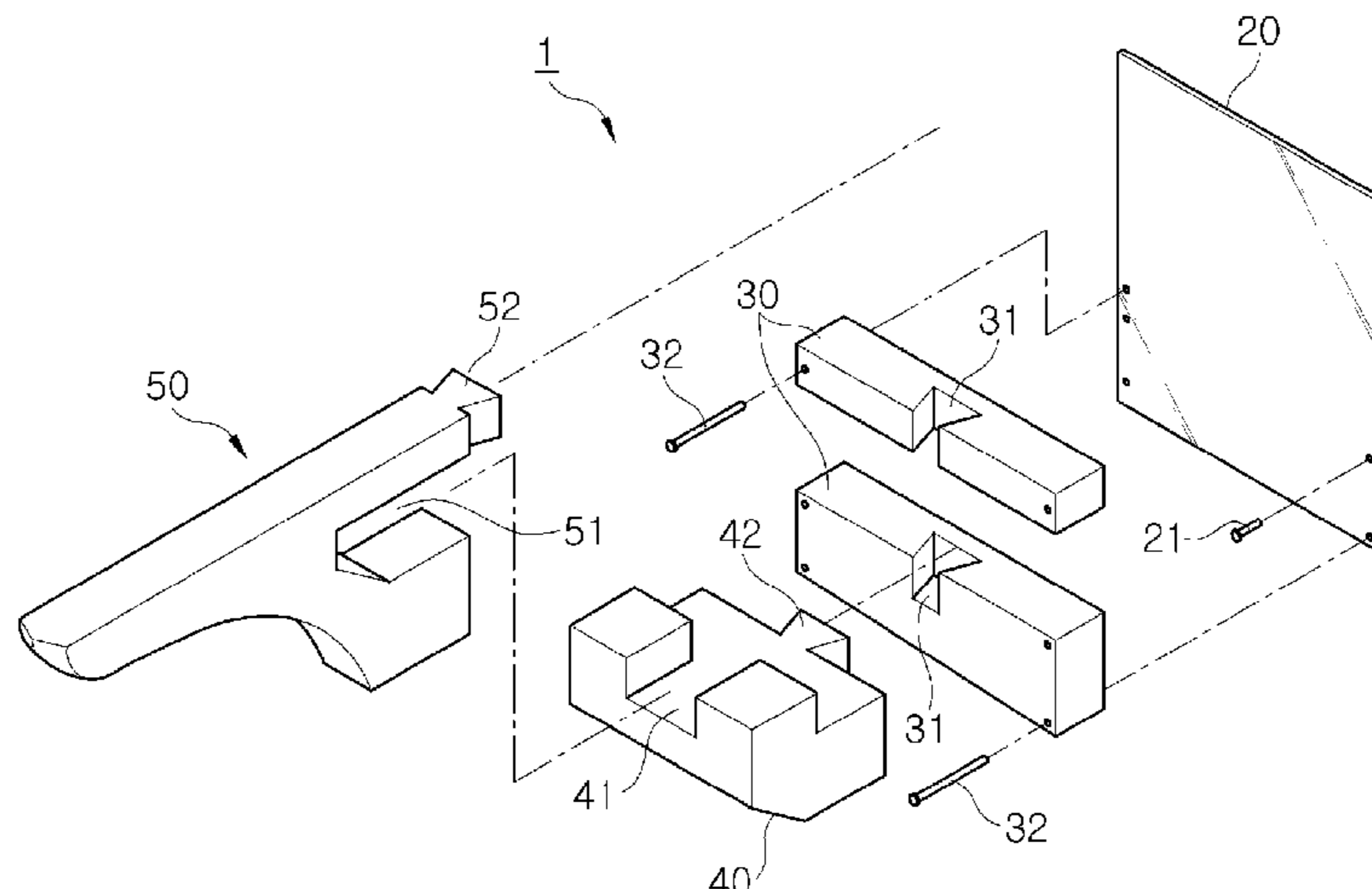

technician to easily perform work only done by a master previously.

**2 Claims, 7 Drawing Sheets**

(51) **Int. Cl.**

*E04D 13/00* (2006.01)  
*E04B 1/26* (2006.01)  
*E04D 1/30* (2006.01)  
*E04D 1/34* (2006.01)

(52) **U.S. Cl.**

CPC ..... *E04D 1/3405* (2013.01); *E04D 13/00* (2013.01); *E04B 2001/2624* (2013.01); *E04B 2001/2652* (2013.01); *E04D 2001/303* (2013.01)

(56)

**References Cited**

U.S. PATENT DOCUMENTS

3,866,371 A \* 2/1975 Falconer ..... E04B 1/185  
 52/281  
 3,966,337 A \* 6/1976 Crawford ..... F16B 12/02  
 403/170

4,409,763 A \* 10/1983 Rydeen ..... E04B 1/26  
 52/93.2  
 4,540,308 A \* 9/1985 Colby ..... F16B 12/00  
 211/189  
 4,873,797 A \* 10/1989 Rydeen ..... E04B 1/10  
 52/93.1  
 4,880,238 A \* 11/1989 Derouin ..... A63F 9/12  
 273/160  
 5,040,797 A \* 8/1991 Dykstra ..... A63F 9/12  
 273/160  
 5,185,982 A \* 2/1993 Hostetler ..... F16B 7/044  
 211/189  
 5,685,120 A \* 11/1997 Sihra ..... A63H 33/06  
 273/156  
 5,799,452 A \* 9/1998 Moore ..... E04B 1/2604  
 52/233  
 6,241,248 B1 \* 6/2001 Winter ..... A63F 9/12  
 2016/0369492 A1 \* 12/2016 Ko ..... E04B 1/165

FOREIGN PATENT DOCUMENTS

KR 1020050078083 A 8/2005  
 KR 100869149 B1 11/2008  
 KR 1020150112476 A 10/2015

\* cited by examiner

FIG. 1

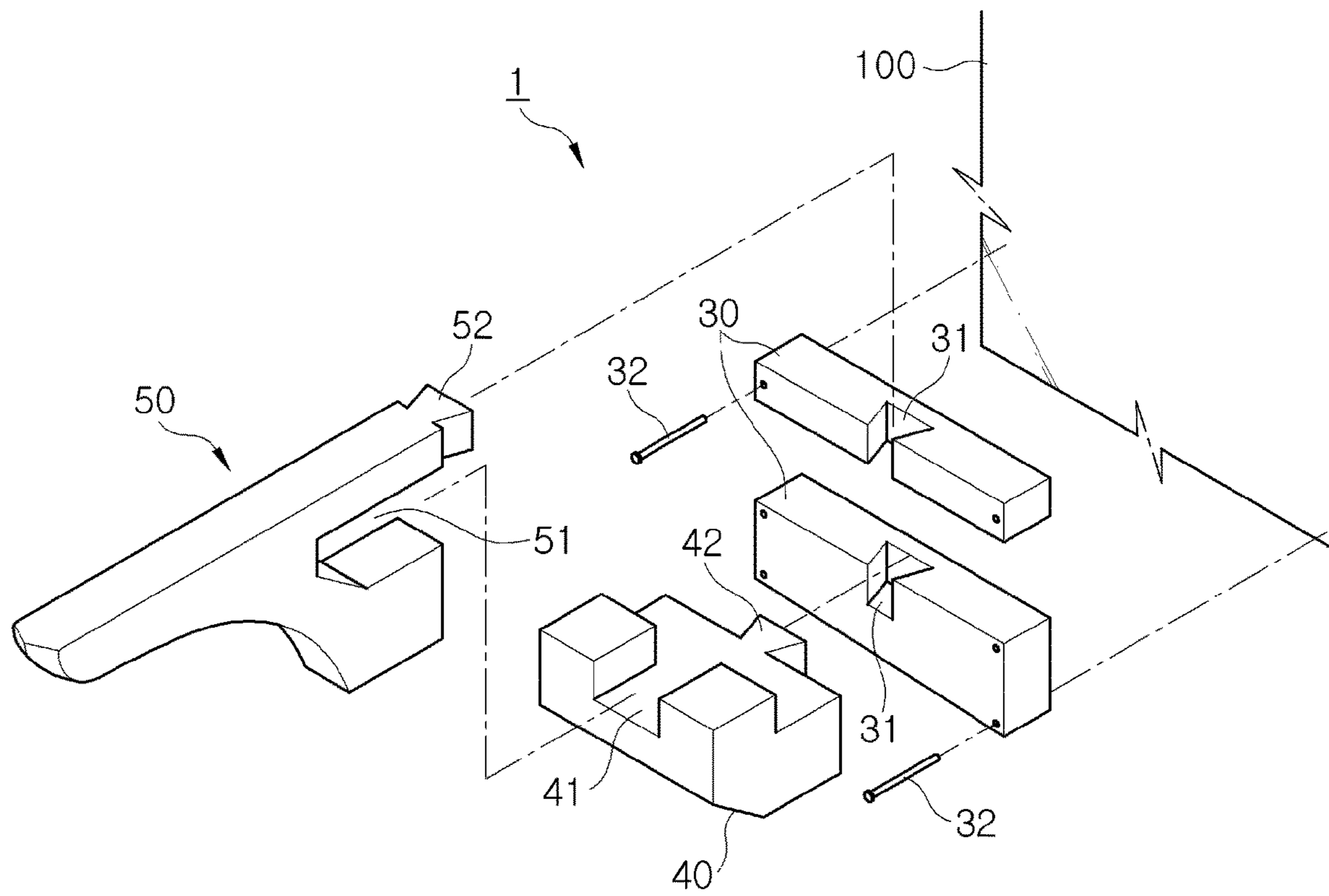

FIG. 2

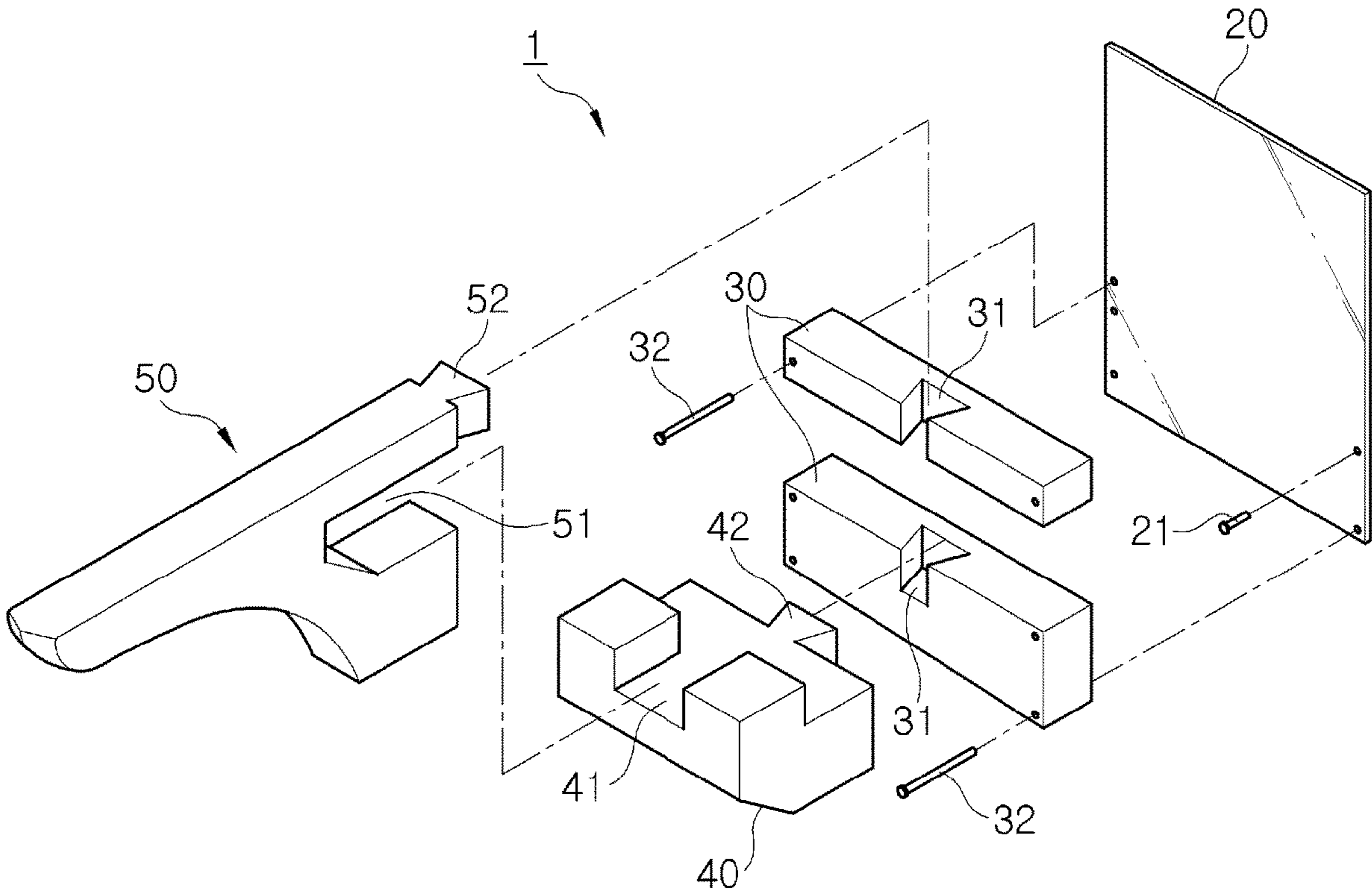

FIG. 3

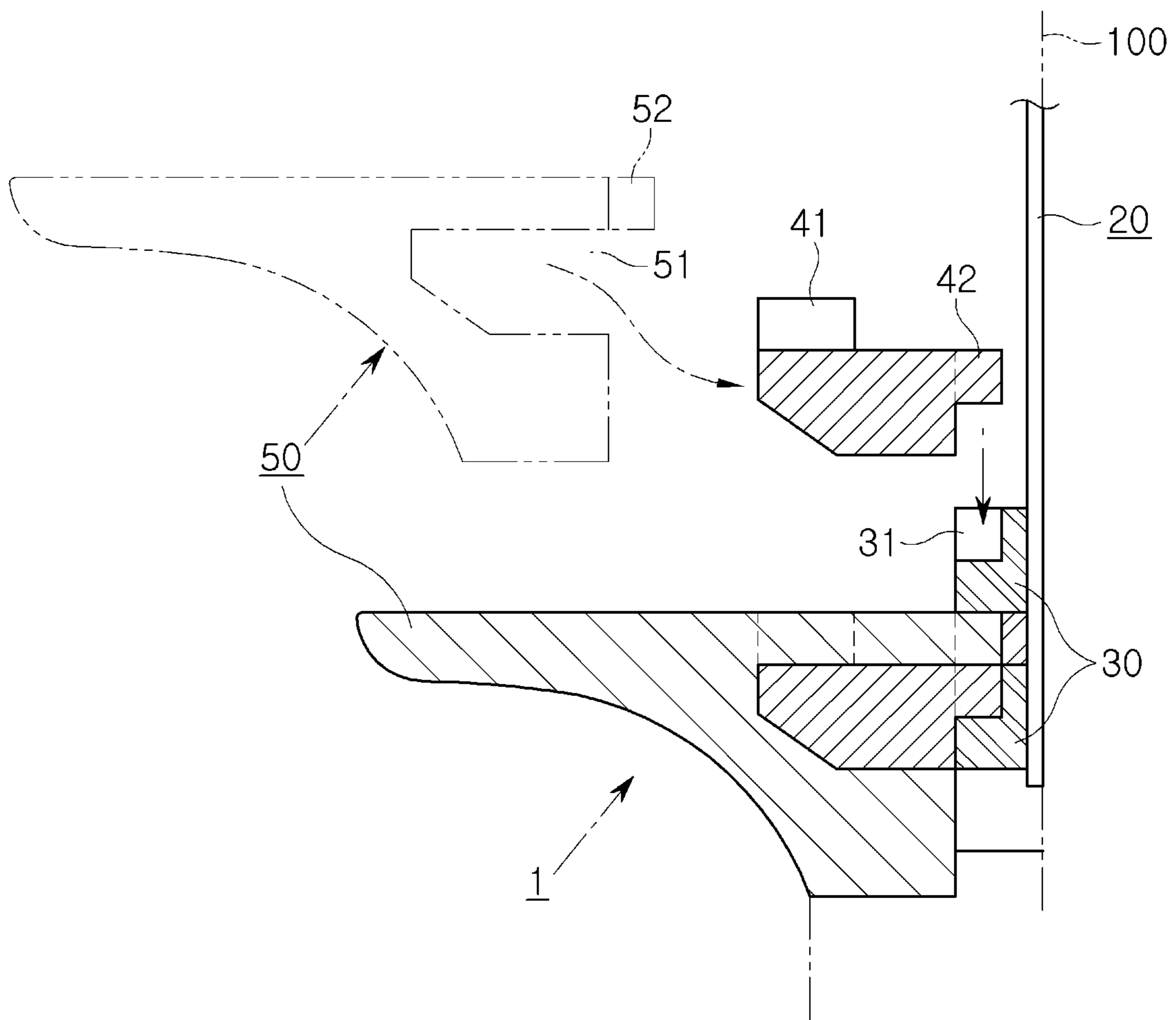



FIG. 4

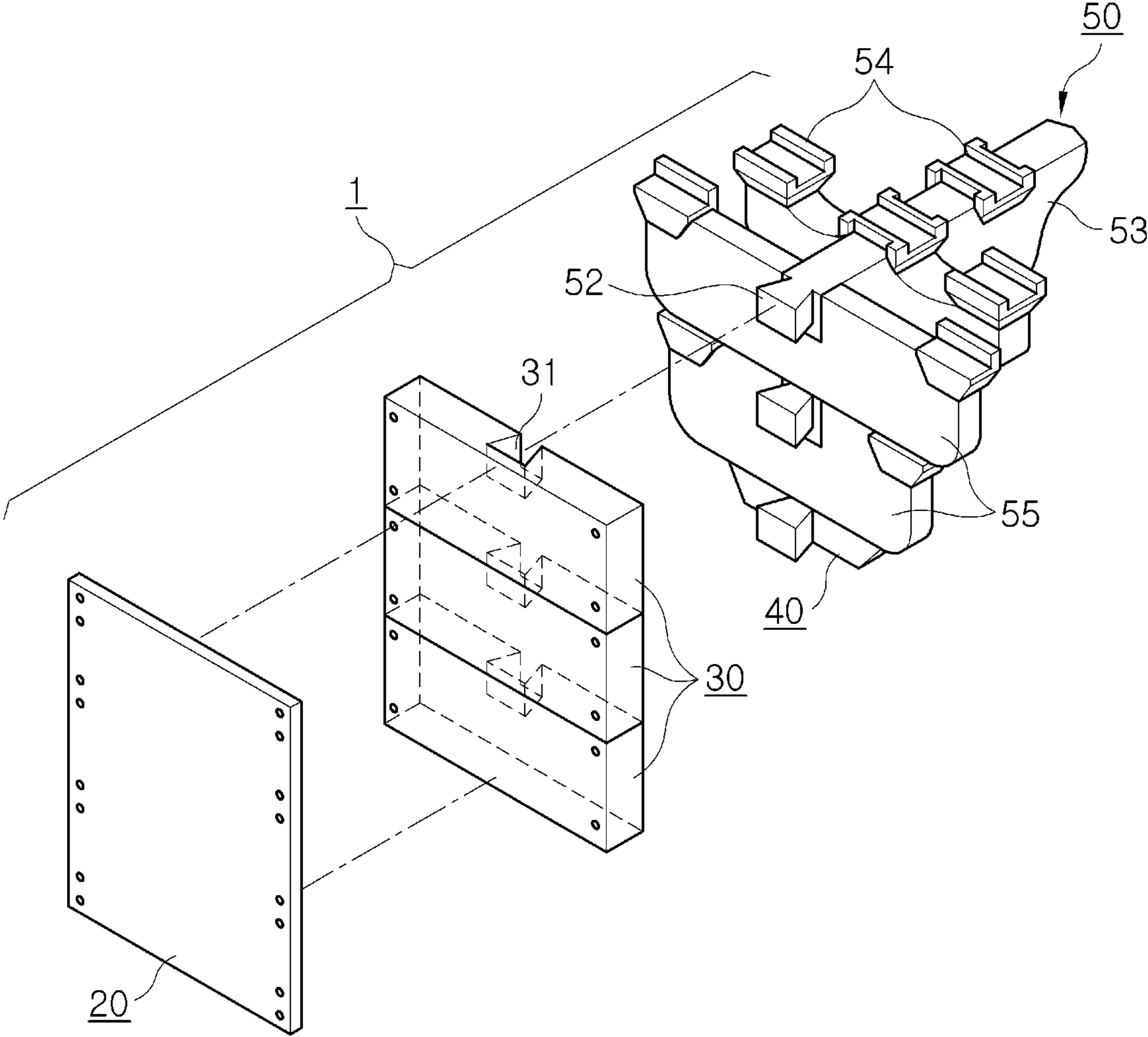

FIG. 5

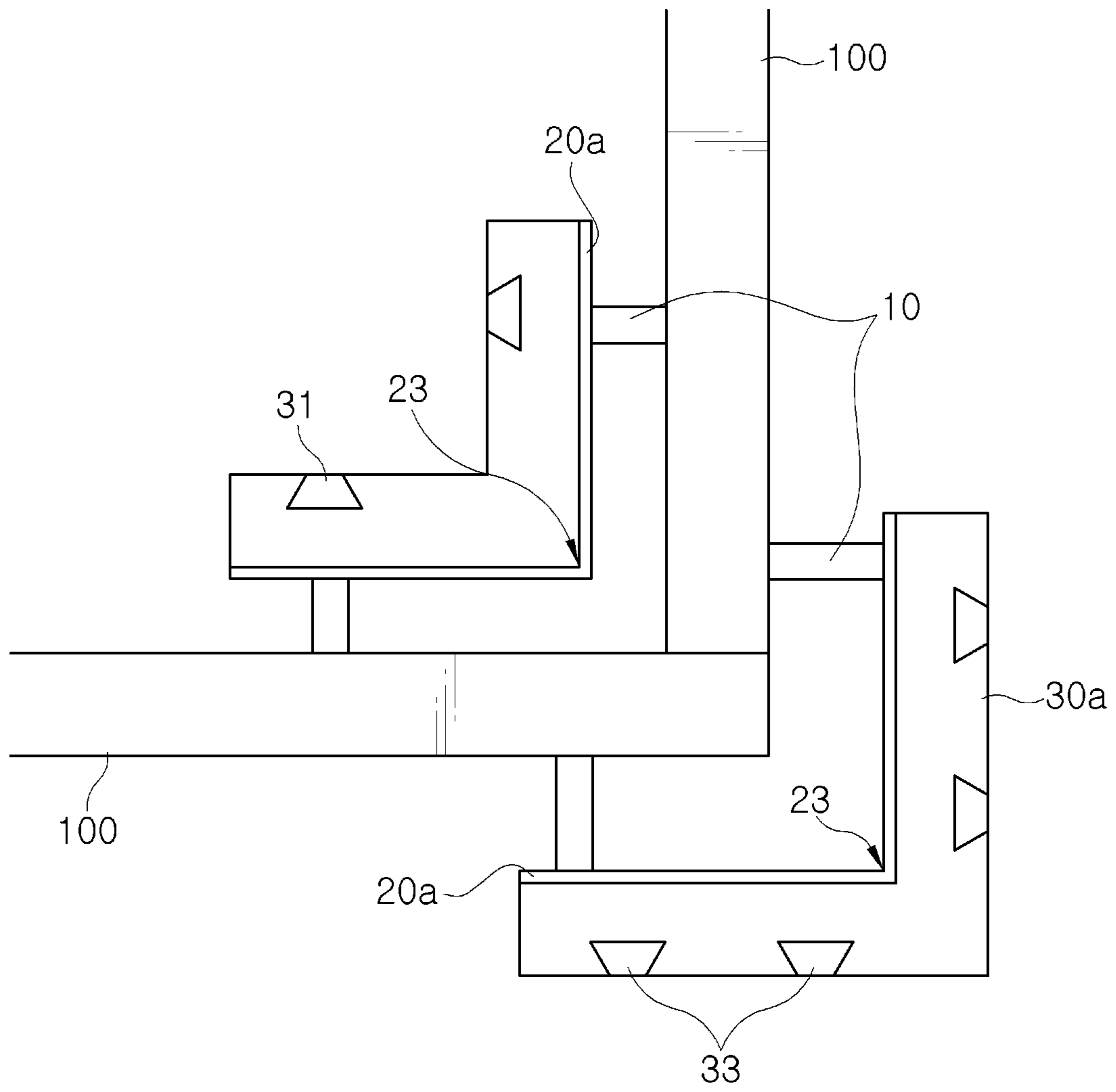

FIG. 6

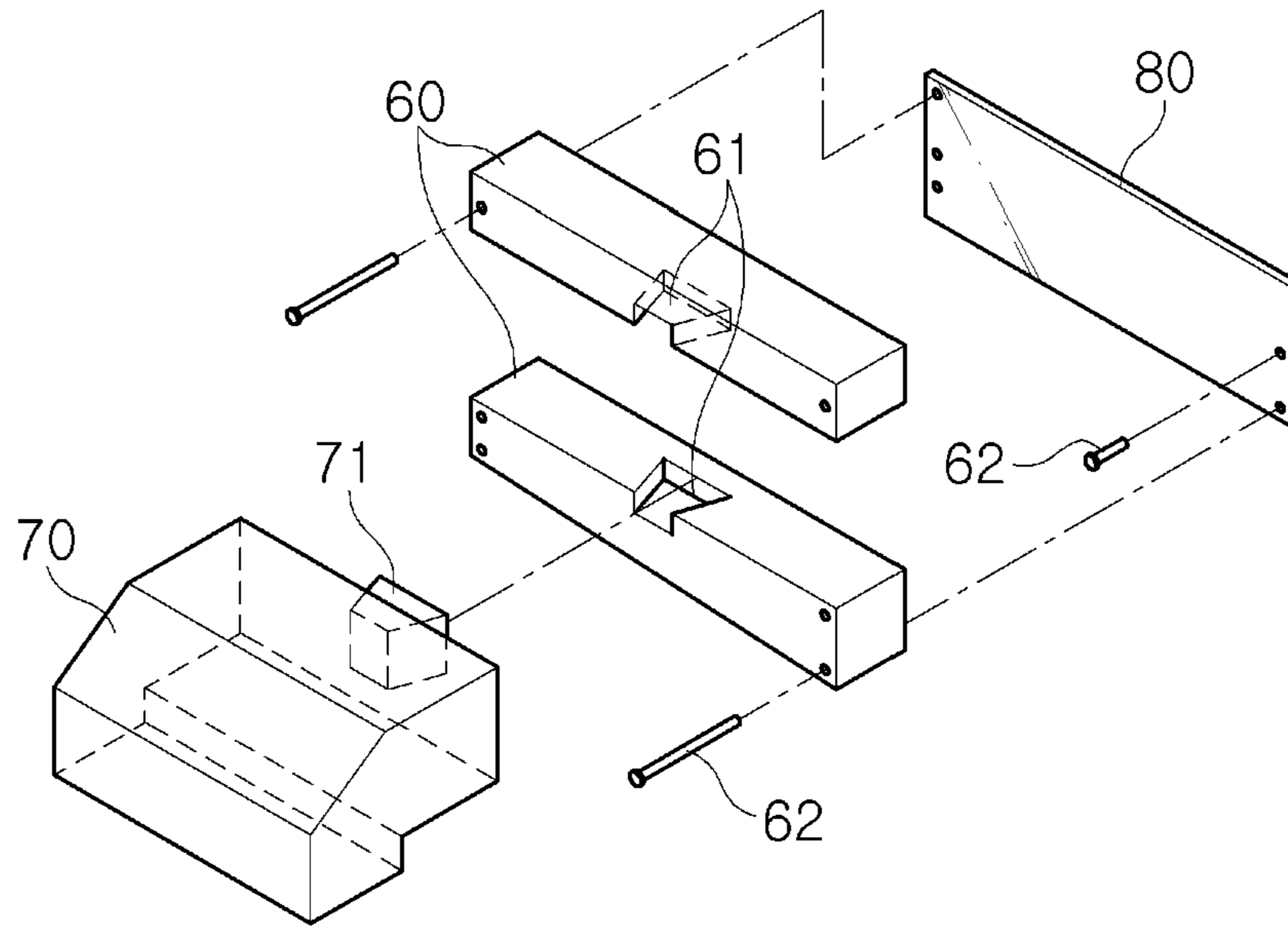
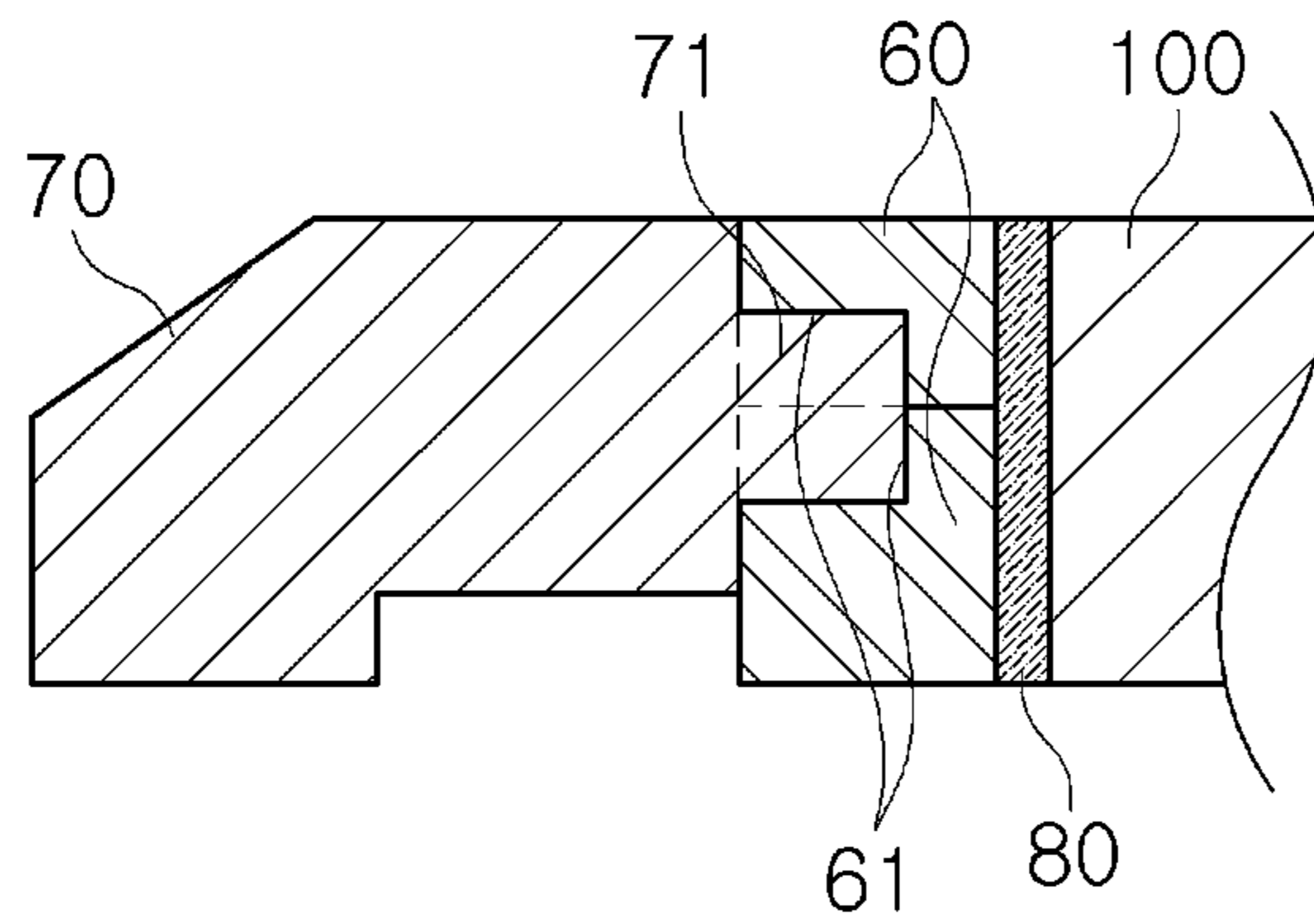

FIG. 7





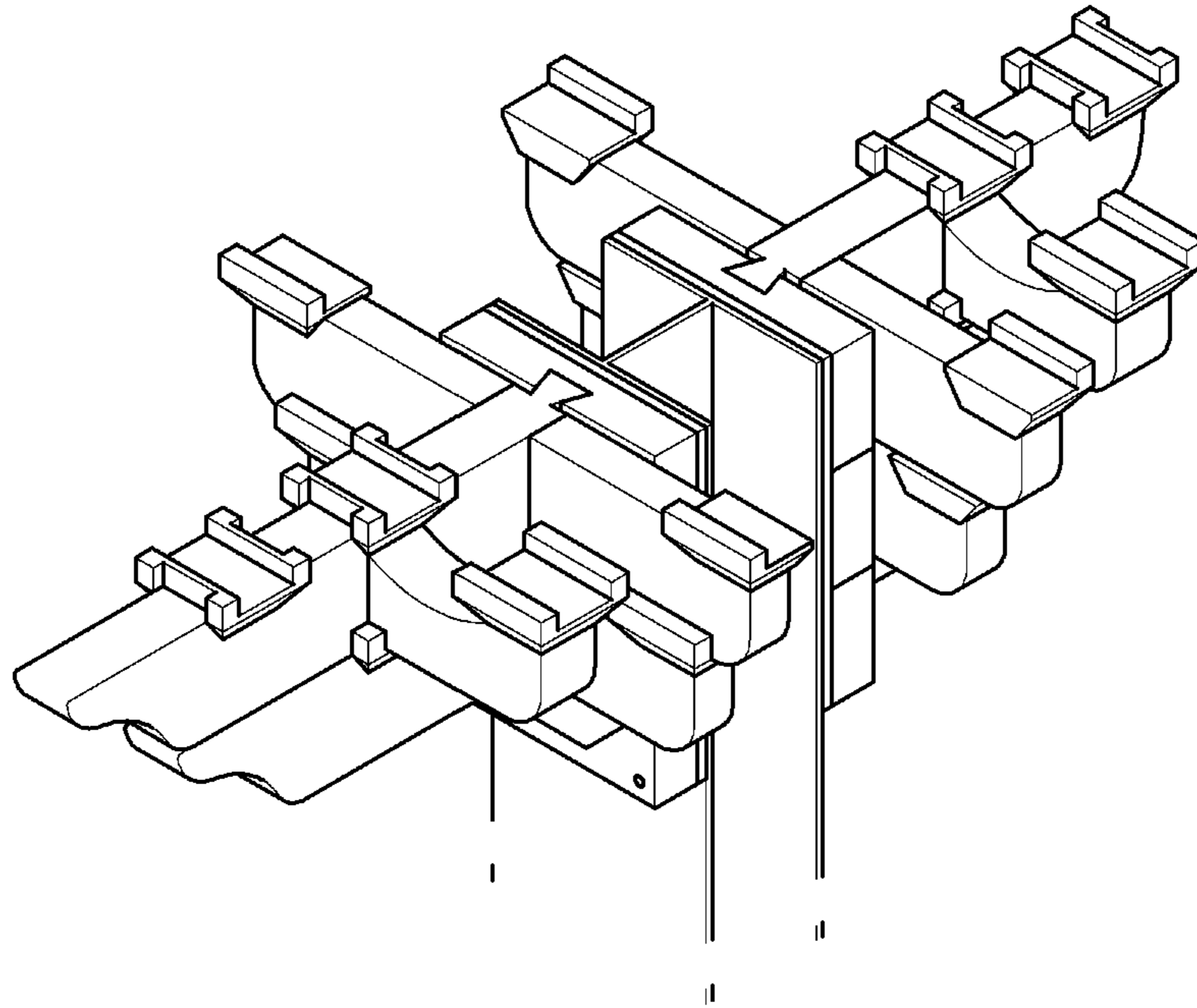

FIG. 8A

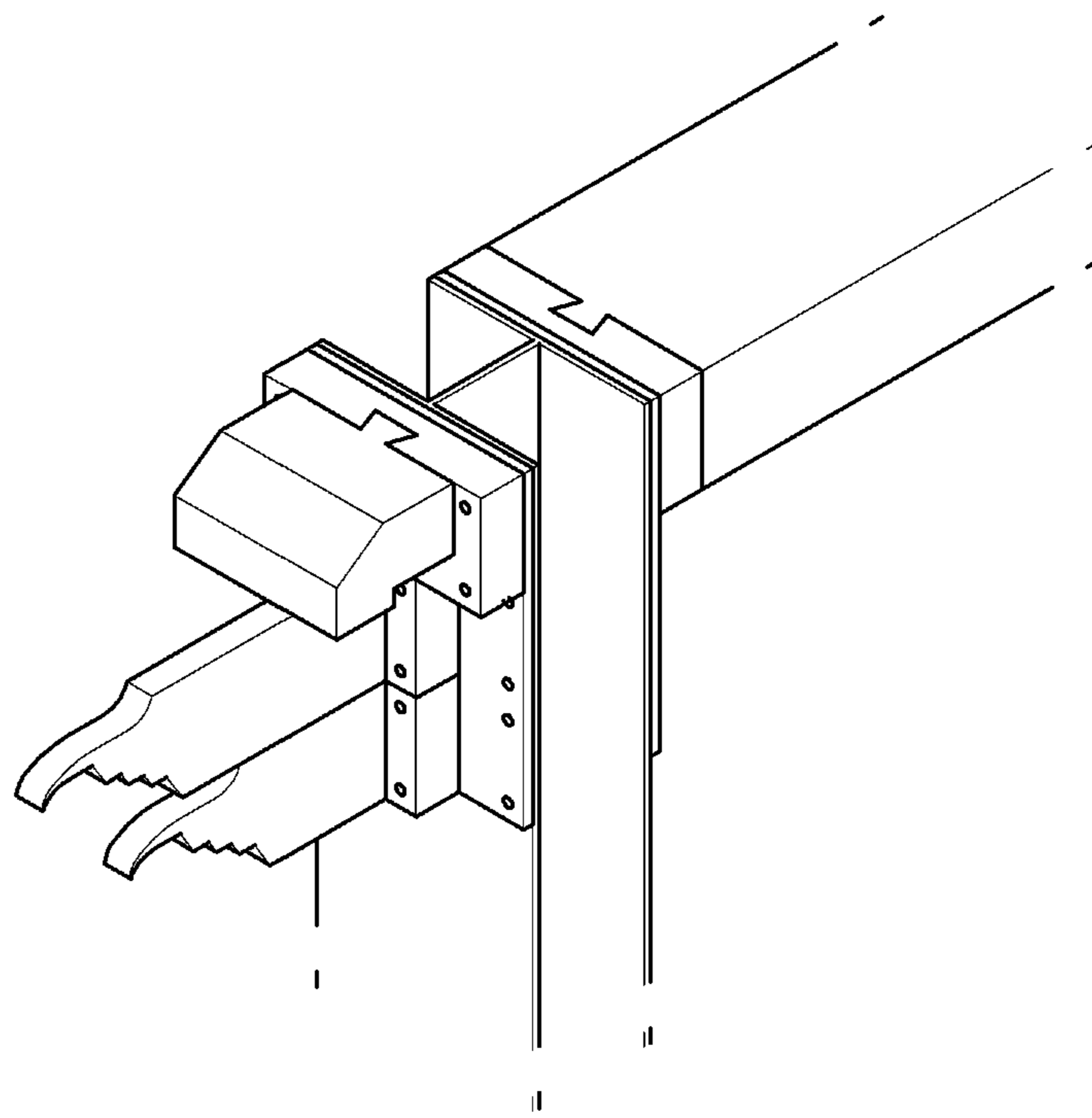

FIG. 8B

# GONGPO ASSEMBLY STRUCTURE OF TRADITIONAL KOREAN-STYLE HOUSE AND TEMPLE

## TECHNICAL FIELD

The present invention relates to a gongpo assembly structure of a traditional Korean-style house, known as a hanok, and temple, wherein the gongpo assembly structure can be quickly and easily attached to or detached from the inside and outside of a fixed object on a construction site. In addition, the gongpo assembly structure formed in various styles and shapes is standardized to be suitable for a design of a hanok and temple, thereby being manufactured and assembled in advance at a factory.

## BACKGROUND ART

Generally, on the one hand a gongpo, known as a corbel bracket set, functions as a structural safety buffer by distributing or concentrating a weight of a building roof. On the other hand, the gongpo shows a magnificent appearance by expanding an interior space and raising a building height. Furthermore, the gongpo has an important function for decorative purposes with delicate and gorgeous composition and structures thereof.

Here, the gongpo is classified into: a jusimpo-style, known as a columnar packaging style; a dapu-style, known as a multi-package style; and an ikkong-style, known as a wing style, depending on a position where the gongpo is placed and a method how the gongpo is combined. In addition, shapes and sizes of the gongpo vary depending on a temple or hanok.

Among them, the jusimpo-style is a style in which a gongpo is woven only on top of a column, a transverse member called changbang is laid between columns by encroaching top of each column with each end thereof, correspondingly, and a hwaban, known as a flower pot, or a pobyeg, known as an open wall, is formed at the center of the changbang.

On the other hand, the dapu-style is a style with a very gorgeous appearance where a gongpo lies not only on top of a column but also between columns. Since a weight of a roof is transmitted through walls as well as columns, it is difficult for a changbang alone to support a load, wherein the changbang is a transverse member connecting with each top of columns. Accordingly, one more transverse member called a pyeongbang is placed on the changbang and the gongpo is formed on the pyeongbang.

In addition, the ikkong-style is a style in which a member is put to be engaged into a top of a column and decorates a gongpo by weaving a judo, known as a capital, a doogong, known as a wooden structure, and a soeseo, known as an oxtongue, thereon, wherein the member looks like a soeseo, outwards at top of the column and acts as a boaji, known as a joint, inward at top of the column. The ikkong is classified into a choikgong, known as a single-wing bracket, and a two-ikgong, known as a variation of the choikgong, depending on the number of pieces of soeseo being laid.

This gongpo functions actually to support a roof of a temple or hanok, and is a typical part boosting beauty of the temple or hanok.

However, in the case of the dapu which is a kind of this gongpo, decorative accessories such as jegong, chemcha, and so on of various styles are made by being carved, and assembled one by one on the site thus taking a lot of time in order to build a magnificent and splendid building. Accord-

ingly, various problems are found such that, along with over expenditure in a labor cost, a construction period is longer due to time needed to assemble the decorative accessories on site, thereby, increasing labor cost.

5 Meanwhile, the Korean Patent No. 0869149 (Date of Publication: Nov. 19, 2008), which was published in the Korean patent publication gazette, discloses "Method for installing eaves-supporting member of traditional Korean-style house and Buddhist temple and structure thereof."

10 The conventional "Method for installing eaves-supporting member of traditional Korean-style house and Buddhist temple and structure thereof" above was to enhance maintainability of a gongpo, which could be seen in traditional Korean-style houses and Buddhist temples, to prevent from being completely destroyed by fire when fire occurred, and to obtain an installation method and structure of the gongpo convenient to install. In this regard, it was proposed to minimize occurrences of losses caused by a fire, a shock, an earthquake, or deterioration which might occur during the long life time of a traditional Korean-style house and Buddhist temple.

15 Here, the structure according to the aforementioned conventional method: is easy to be assembled and installed; has a preservation period much longer than other structures that use a method of connecting reinforcing bars because all the joint structures thereof are assembled by fitting; and has an advantage of being able to withstand an earthquake without collapse due to an effect of blocking the transmission of vibration because a foundation structure for connection is formed in two layers. However, the aforementioned conventional method has problems such that the structure is formed in a concrete structure through curing to be assembled on the construction site, whereby the manufacturing process is troublesome, and the structure formed as concrete structure is not only heavy but also vulnerable to impact, whereby installation thereof cannot be implemented quickly at the construction site, and the entire structure should be replaced when a damage occurs.

20 Meanwhile, a bo, known as a beam, conveys a weight of a roof on a column, meets a torii, known as a supporting member, at a right angle, and is formed in various sizes and shapes according to a size of a hanok or temple. This bo is forced to be engaged with a soro on a chemcha when meeting a gongpo placed on a column, and forms a bomeoli, known as a head of the beam, on the gongpo.

25 Such a bomeoli is exposed to the outside together with a gongpo, and a special decoration is engraved thereon or handiwork is realized in various configurations thereof, whereby a decorative function is given thereto.

30 However, even in the case of the bomeoli, it is necessary to carve various types of the bomeoli at the construction site similarly to the gongpo construction method described as above. Accordingly, various problems occur such that, along with over expenditure in a labor cost, a construction period is longer due to time needed to assemble the bomeoli on the site, thereby, increasing labor cost.

## DISCLOSURE

### Technical Problem

35 Accordingly, the present invention has been made to solve the above problems, and it is an object of the present invention to provide a hanok and temple that allow construction period to be shortened and labor cost to be reduced by simplifying the installation, maintenance, and manage-



ment of the gongpo assembly structure by providing a fixing member having an interlocking slot.

In addition, it is another object of the present invention to provide the gongpo assembly structure of a hanok and temple that is economic due to use of a short member, and further enhances an esthetic sense of a hanok by allowing the inside and outside structure of the gongpo assembly structure to be separately formed, and to be installed inside and outside a building with respect to a center axis of the fixed object, respectively.

#### Technical Solution

In order to accomplish the above object, the present invention provides a gongpo assembly structure of a traditional Korean-style house (hanok) and temple, the gongpo assembly structure including: at least one gongpo fixing member, each provided with an interlocking slot formed in a shape depressed toward lower and inward directions from an surface thereof, and laid one upon another by being fastened to the fixed object; a judo provided with a wide open groove formed on a center of a top surface thereof and an interlocking protrusion formed on one side wall thereof and interlocked with the interlocking slot of the gongpo fixing member; and a gongpo assembled with a top of the judo, and interlocked with the interlocking slot of the gongpo fixing member.

In addition, the gongpo assembly structure may further include a fixing plate provided on a rear surface of the gongpo fixing member and fastening the gongpo assembly structure to the fixed object by being fastened to the fixed object.

In addition, the gongpo assembly structure may include: a bomeoli provided with an interlocking protrusion formed on one side wall thereof, wherein, the bomeoli is assembled by at least one bomeoli fixing member provided with an interlocking slot formed in a shape depressed toward lower and inward directions from an surface thereof and interlocked with the interlocking protrusion of the bomeoli, and laid one upon another by being fastened to the fixed object.

Here, the gongpo assembly structure may be each installed inside and outside a center axis of the fixed object of the hanok and temple, respectively, by the gongpo fixing member or the fixing plate.

In addition, the fixing plate may further include a fixing plate formed with a corner portion connecting two surfaces, and the gongpo fixing member may further include a gongpo fixing member provided with at least one interlocking slot formed in a shape depressed toward lower and inward directions from a surface thereof, and formed with the corner portion connecting the two surfaces, wherein both of the fixing plate and the gongpo fixing member are installed to the inside and outside corners of the fixed object of the hanok and temple, respectively.

#### Advantageous Effects

As described above, according to the present invention, it is possible to standardize and mass-produce the gongpo assembly structure at a factory. Accordingly, there are advantages that a general technician is allowed to easily do the work only done by a master previously, and an assembled gongpo assembly structure is quickly and easily installed at the construction site of the hanok and temple, wherein the gongpo assembly structure or dancheong, Korean art of painting buildings, of the gongpo assembly may be implemented at the factory rather than at the

construction site of the hanok or temple. In addition, there are effects of shortening the construction period, reducing labor cost, and so on by enabling the gongpo assembly structure to be quickly assembled at the site through repair thereof as the gongpo assembly structure is easily separated from the fixed object when it is damaged.

In addition, the present invention allows the inner and outer structures of the gongpo assembly structure including the gongpo assembly structure to be separately formed, and to be installed inside and outside of the center axis of a fixed object. Accordingly, there are advantages that stress due to a load is eliminated even in the case of losses of various members due to termites eating the wood, while an esthetic sense of a hanok is further enhanced, and economic effects such as convenience of maintenance, convenience of construction, shortening of construction period, reduction in a labor cost, and so on are greatly improved.

#### DESCRIPTION OF DRAWINGS

FIG. 1 is an exploded perspective view of a dapu assembly structure according to a first embodiment of the present invention.

FIG. 2 is an exploded perspective view of a dapu assembly structure according to a second embodiment of the present invention.

FIG. 3 is an enlarged vertical sectional view showing the assembled state of the dapu assembly structure according to FIG. 2.

FIG. 4 is a view showing an example of a dapu assembly structure according to the present invention.

FIG. 5 is a view showing an example of dapu assembly structures according to the present invention each constructed at the inside and outside corners of a hanok and temple, respectively.

FIG. 6 is an exploded perspective view of a bomeoli assembly structure according to a third embodiment of the present invention.

FIG. 7 is an enlarged vertical sectional view showing an assembled state of the bomeoli assembly structure according to FIG. 6.

FIG. 8A and FIG. 8B illustrate views of various application examples of the present invention (FIG. 8A shows a dapu assembly structure, and FIG. 8B shows an ikkong assembly structure).

#### MODE FOR INVENTION

The present invention relates to a gongpo assembly structure that performs important decorative functions in a hanok and temple, and may be applied to various gongpo-styles (a dapu-style, an ikkong-style, and so on). In addition, the present invention may be applied not only to a traditional construction style but also to various construction styles by appropriate modifications of a design.

Hereinafter, the present invention will be described in detail with reference to the accompanying drawings.

FIG. 1 illustrates a first embodiment of the present invention, and shows an exploded perspective view of a dapu assembly structure according to the dapu-style among the gongpo-styles.

As illustrated in FIG. 1, the dapu assembly structure 1 of the dapu assembly structure according to the first embodiment of the present invention includes: at least one dapu fixing member 30 provided and laid one upon another; a judo 40 assembled with the dapu fixing member 30; and a dapu 50 assembled with the judo 40.



## 5

Here, because shapes and configurations of the dapō assembly structure **1** including the dapō fixing member **30**, the judu **40** and the dapō **50** may be variously formed according to the architectural style of a temple or hanok, and sizes and the like thereof may be different, it is not preferable for the dapō assembly structure to specify or limit to the shapes shown in the first embodiment of the present invention.

The dapō fixing member **30** according to the first embodiment of the present invention is provided with an interlocking slot **31** formed in a shape depressed toward lower and inward directions from a surface thereof and is fastened to the fixed object **100**, between the upper portion of the column constituting a building and the lower portion of the torii, by bolts **32**.

Here, at least one dapō fixing member **30** may be formed and laid one upon another to install the dapō **50** suitable for an architectural style, wherein the dapō fixing member **30** may have different shape, size, or height, but should be provided with an interlocking slot **31**, individually.

Meanwhile, the judu **40** to be interlocked with the dapō fixing member **30** by interlocking is formed with a wide open groove **41** at a center of a surface thereof and with an interlocking protrusion **42** in one side wall thereof to be inserted and interlocked with the interlocking slot **31**. Accordingly, the judu **40** is assembled with the interlocking protrusion **42** being inserted into the interlocking slot **31**. In addition, the dapō **50** has an inward interlocking slot **51** and an interlocking protrusion **52**, and is assembled in a seated state in a wide open groove **41** of the judu **40**, wherein the interlocking protrusion **52** is assembled by being inserted into the interlocking slot **31** of another different dapō fixing member **30** placed by being laid upon the dapō fixing member **30**. Finally, the assembled dapō assembly structure is fastened directly to the fixed object **100** by bolts **32**.

FIG. **2** is an exploded perspective view of a dapō assembly structure according to a second embodiment of the present invention, and FIG. **3** is an enlarged vertical sectional view showing the assembled state of the dapō assembly structure according to FIG. **2**, wherein these drawings illustrate a second embodiment of the present invention.

The second embodiment according to the present invention is, differently from the first embodiment, further provided with a fixing plate **20** fastened by bolts **21** to a horizontal or vertical surface of a part of the fixed object, between the upper part of the column constituting the building and the lower part of the torii, **100** constituting the inner and outer parts, that is, the interior and exterior of the multi-storied hanok and temple. Here, the dapō assembly structure **1** including the dapō fixing member **30** fastened to the front surface of the fixing plate **20**, the judu **40** assembled with the dapō fixing member **30** by interlocking; and the dapō **50** assembled on the top of the judu **40** is fastened to the fixing plate **20** by the bolts **32** passing through the dapō fixing member **30**, wherein the fixing plate **20** may be fastened to the fixed object **100** subsequently.

As can be seen in FIG. **4**, the dapō **50** as above according to the dapō assembly structure of the hanok and temple according to the present invention is composed of the judu **40**, a salmi **53**, a soro **54**, a chemcha **55**, and so on. Since the dapō assembly structure **1** including the dapō **50** is designed to be suitable for the style of the hanok and temple to be constructed, and can be formed in one of various shapes, sizes, or heights, it needs not for the dapō assembly structure **1** to be specific or limited to the drawings illustrated in the present invention.

## 6

The dapō assembly structure **1** according to the first and second embodiments of the present invention is mass-produced in a standardized state at a factory, thereby allowing a general technician to perform work only done by a master previously, and the construction period to be shortened due to dancheong that may be performed in advance at the factory other than at the construction site of the hanok and temple.

A plurality of dapō fixing members **30** are installed on one selected from the fixed object **100** and the fixing plate **20** according to the present invention, wherein, in front of the dapō fixing members **30**, the interlocking protrusion **42** of the judu **40** is assembled by being inserted into the interlocking slot **31** of the dapō fixing member **30**.

In addition, the interlocking slot **51** of the dapō **50** is inserted on the top of the judu **40** from the outside of the judu **40** and the interlocking protrusion **52** of the dapō **50** is inserted into and assembled with the interlocking slot **31**. Subsequently, the completely assembled dapō assembly structure **1** is completed to be installed by being fastened on the site on the horizontal or vertical surface of the fixed object **100** or the fixing plate **20** constituting the multi-storied hanok and temple.

When the dapō assembly structure **1** according to the present invention is assembled in advance at the factory, the construction period on the site may be greatly shortened. Here, the number of dapō assembly structures **1** fastened to the fixed object **100** or the fixing plate **20** may vary depending on the style of the hanok and temple.

Meanwhile, FIG. **5** is a view showing an example of dapō assembly structures according to the present invention each constructed at the inside and outside corners of a multi-storied hanok and temple, respectively, wherein another example of the fixing plate **20** and the dapō fixing member **30** can be seen.

As can be seen in the abovementioned drawing, a fixing plate **20a** is formed with a corner portion **23** connecting two surfaces. That is, the dapō fixing member **30a** is provided with at least one interlocking slot **33** formed in a shape depressed toward the lower and the inward directions from a surface thereof, and with the corner portion **23** connecting the two surfaces, whereby the dapō fixing member **30a** can be quickly and easily installed to the inside and outside corners which are the inside and outside of the fixed object **100** of the multi-storied hanok and temple, respectively. Here, in the same way, the fixing plate **20a** is fastened by the bolt **32** to a bracket **10** fastened to the fixed object **100**, and the dapō fixing member **30a** is also fastened by the bolt to the fixing plate **20a**. Here, reference numeral **10** denotes a bracket that is to place the fixing plate **20a** spaced apart from the fixed object **100** as necessary, and may not be necessarily needed.

FIG. **6** is an exploded perspective view of a bomeoli assembly structure according to a third embodiment of the present invention, and FIG. **7** is an enlarged vertical sectional view showing an assembled state of the bomeoli assembly structure according to FIG. **6**.

The third embodiment relates, differently from the first and second embodiments, to a bomeoli assembly structure that is installed on one side of top of a column by being added to the dapō-style or the ikkong-style of the gongpo-styles of the hanok and temple.

Similarly to the first embodiment, the bomeoli assembly structure includes: at least one bomeoli fixing member **60** provided with an interlocking slot **61** formed in a shape depressed toward the lower and inward directions from an surface thereof, and laid one upon another by being fastened



to the fixed object **100** by the bolts; and a bomeoli **70** provided with an interlocking protrusion **71** formed in the one side wall thereof, and interlocked in the interlocking slot **61**.

The shape and configuration of the bomeoli **70** can be variously formed according to the architectural style of the temple or hanok, and the size and the like can be varied. In addition, the bomeoli assembly structure may be further provided on one side of a bo placed on top of the dapo assembly structure. Accordingly, it is not preferable for the bomeoli assembly structure to be specific or limited to the shape or configuration shown in the third embodiment of the present invention.

As in the first and second embodiments, the bomeoli fixing member **60** according to the third embodiment of the present invention is provided with an interlocking slot **61** formed in a shape depressed toward the lower and the inward directions from an surface thereof the same as the dapo fixing member, and fastened to the fixed object that is a top side of a dapo assembly structure, a top side of a column, a one side of a Bo, or an end of the Bo, **100** by the bolt **62**.

Here, at least one bomeoli fixing member **60** may be formed and laid one upon another to install the bomeoli **70** suitable for an architectural style, wherein the bomeoli fixing members **60** may have different shape, size, or height, but should be provided with an interlocking slot **61**, individually.

The bomeoli assembly structure is assembled by inserting the interlocking protrusion **71** of the bomeoli **70** into the interlocking slot **61** formed in the bomeoli fixing member **60**. According to the architectural style, a plurality of pieces of the bomeoli in various shapes can be formed and coupled by being assembled with the bomeoli fixing member **60** and other bomeoli. To this end, separate interlocking slots and interlocking protrusions may be formed in the bomeoli similarly to the dapo assembly structure.

As described above, the bomeoli assembly structure may be directly formed with the bomeoli **70** being fastened to the fixed object (a top side of a dapo assembly structure, one side of a bo, or an end of the bo) **100** by the bolts **62** with the interposition of the bomeoli fixing member **60**. However, the bomeoli assembly structure may be further provided with a fixing plate **80** fastening the bomeoli **70** to the fixed object **100**, wherein the fixing plate **80** is placed between the rear surface of the bomeoli fixing member **60** and the fixed object **100**, and fastened to the fixed object **100** by the bolts **62**.

Similarly to the second embodiment of the present invention, this is to further provide the fixing plate **80** fastened between the bomeoli fixing member **60** and the fixed object **100** by the bolts **62**, and to allow the bomeoli **70** or the bomeoli assembly structure to be fastened to the fixing plate **80** by the bolt **62** passing through the bomeoli fixing member **60**, whereby the fixing plate **80** is fastened to the fixed object **100** subsequently.

In the case where the bomeoli **70** is composed of a plurality of pieces of the bomeoli in various shapes and sizes and is formed as a single bomeoli assembly structure, this is to fasten the single bomeoli assembly structure to the fixing plate **80** first, and then to fasten the fixing plate **80** fastening the single bomeoli assembly structure to the fixed object **100**. The single bomeoli assembly structure, no matter how complex it is, is fastened to the fixing plate **80** in advance and is only coupled with the fixed object **100** subsequently, thereby enabling installation by any general technician.

Accordingly, shortening of a construction period and reducing of a labor cost may be realized.

Meanwhile, although the above embodiment has been described in detail regarding the dapo-style among the gongpo-styles, the present invention is not limited thereto, and can be applied to the ikkong-style as well as to the hanok or temple appropriately according to the architectural style thereof.

FIG. **8** illustrates views of various application examples of the present invention, wherein (a) shows a dapo assembly structure, and (b) shows an ikkong assembly structure. These drawings illustrate examples that the present invention may be applied to the dapo-style and the ikkong-style.

As shown in FIG. **8**, the gongpo assembly structure like this is preferably installed by the gongpo fixing member or the fixing plate inside and outside the building, respectively, with respect to the center axis of the fixed object of the hanok or the temple.

That is, the gongpo assembly structure is required to form integrally with inner and outer decorative members in the existing hanok, wherein each of component and connection structure thereof should be assembled all by fitting. Consequently, there are problems that the gongpo assembly structure in the existing hanok is difficult to install and the entire gongpo assembly structure should be replaced when a part thereof is to be replaced due to breakage.

However, the present invention allows basically the inner and outer configurations of the gongpo assembly structure including the gongpo assembly structure, for example, the dapo assembly structure or the ikkong assembly structure, to be provided separately and to be installed inside and outside the building with respect to the center axis of the fixed object, respectively.

To this end, the present invention introduces a gongpo fixing member or a fixing plate, and allows effects such as convenience of construction, shortening of construction period, reduction in a labor cost, and so on to be realized by a method of fastening the gongpo fixing member and the fixing plate coupled with the gongpo assembly structure to the fixed object.

Particularly, the present invention may be applicable to a multi-storied hanok or temple. In addition, the present invention may be applied not only to a traditional hanok architecture but also to a composite architecture which uses a method deviated from the traditional one, wherein the composite architecture provides a hanok or temple with a structure formed in a steel structure, H beam, and uses the steel structure and wood. In this regard, FIG. **8** shows that the gongpo assembly structure according to the present invention is installed inside and outside the fixed object steel structure, in this composite construction method.

Accordingly, the present invention is possible to realize not only a single-storied but also a multi-storied hanok, and to minimize problems such as the loss of various members due to termites eating the wood, whereby it is possible to realize a building that is convenient for repair, maintenance and management, and is excellent in durability.

Especially, the assembled gongpo assembly structure can be installed quickly and conveniently at a site after completing the gongpo by assembling at a factory rather than a construction site, wherein the gongpo is most important for decorative purposes in the hanok architectural style, and takes a relatively long time for installation. As a result, while enhancing an esthetic sense of a hanok, the present invention greatly improves economic effects such as convenience of maintenance, convenience of construction, shortening of construction period, reduction in a labor cost, and so on.



As described above, the present invention can enable quick and easy assembly of the gongpo assembly structure, prefabricated quickly and easily at the factory, at the construction site of the hanok, or multi-storied house, and temple, thereby reducing the construction period of the hanok and temple, reducing labor cost, and providing convenience for maintenance and management. In addition, the gongpo assembly structure can be quickly replaced after being easily separated from the fixed object in the case of breakage.

As above, the terms and words used in the present specification and claims should not be construed in a conventional sense or as defined in a dictionary. The present invention should be construed in accordance with the meaning and concept consistent with the technical idea of the present invention based on a principle that the inventor is entitled to define properly the concept of the term in order to describe its invention in the best way possible.

Accordingly, the first to third embodiments and the configurations illustrated in the drawings are only preferred embodiments of the present invention, and do not represent all of the technical ideas of the present invention. Consequently, it should be understood that various equivalents and modifications might be possible at the time of the application.

The invention claimed is:

1. A structure of a traditional Korean-style house and temple, the structure comprising:

a plurality of gongpo assembly structure each including:

a gongpo fixing member fastened to a fixed object and having a lower gongpo fixing member part in which a lower interlocking slot portion is formed and an upper gongpo fixing member part stacked on the lower gongpo fixing member part and in which an upper interlocking slot portion is formed;

a judu provided with a wide open groove formed on a center of a top surface thereof and an interlocking protrusion formed on one side wall thereof and interlocked with the lower interlocking slot portion of the lower gongpo fixing member part;

a gongpo assembled with a top of the judu, and interlocked with the upper interlocking slot portion of the upper gongpo fixing member part, and

a fixing plate provided between the gongpo fixing member and the fixed object and fastening the gongpo fixing member to the fixed object,

wherein the lower interlocking slot portion extends downward from a top surface of the lower gongpo fixing member part and has a height lower than the lower gongpo fixing member part, such that a lower surface of the lower interlocking slot portion supports the interlocking protrusion of the judu,

the upper interlocking slot portion extends between a top surface and a bottom surface of the upper gongpo fixing member,

the lower interlocking slot portion and the upper interlocking slot portion are arranged in one vertical line, and

some of the gongpo assembly structures are installed inside a center axis of the fixed object of the traditional Korean-style house and temple and some other of the gongpo assembly structures are installed outside the center axis of the fixed object of the Korean-style house and temple, by the gongpo fixing member or the fixing plate.

2. A gongpo assembly structure of a traditional Korean-style house and temple, the gongpo assembly structure comprising:

a gongpo fixing member fastened to a fixed object and having a lower gongpo fixing member part in which a lower interlocking slot portion is formed and an upper gongpo fixing member part stacked on the lower gongpo fixing member part and in which an upper interlocking slot portion is formed;

a judu provided with a wide open groove formed on a center of a top surface thereof and an interlocking protrusion formed on one side wall thereof and interlocked with the lower interlocking slot portion of the lower gongpo fixing member part; and

a gongpo assembled with a top of the judu, and interlocked with the upper interlocking slot portion of the upper gongpo fixing member part, and

a fixing plate provided between the gongpo fixing member and the fixed object and fastening the gongpo fixing member to the fixed object; and

wherein the lower interlocking slot portion extends downward from a top surface of the lower gongpo fixing member part and has a height lower than the lower gongpo fixing member part, such that a lower surface of the lower interlocking slot portion supports the interlocking protrusion of the judu,

the upper interlocking slot portion extends between a top surface and a bottom surface of the upper gongpo fixing member,

the lower interlocking slot portion and the upper interlocking slot portion are arranged in one vertical line, the fixing plate is formed to have a corner portion connecting two flat portions, and the gongpo fixing member has a same shape as the fixing plate, and

both of the fixing plate and the gongpo fixing member are installed to the inside or outside corner of the fixed object of the Korean-style house and temple.

\* \* \* \* \*