



US010677925B2

(12) **United States Patent**
Boehmke

(10) **Patent No.:** **US 10,677,925 B2**
(45) **Date of Patent:** **Jun. 9, 2020**

(54) **ADJUSTABLE BEAM PATTERN FOR LIDAR SENSOR**

(71) Applicant: **UATC, LLC**, San Francisco, CA (US)

(72) Inventor: **Scott Boehmke**, Pittsburgh, PA (US)

(73) Assignee: **UATC, LLC**, San Francisco, CA (US)

(*) Notice: Subject to any disclaimer, the term of this patent is extended or adjusted under 35 U.S.C. 154(b) by 0 days.

(21) Appl. No.: **16/035,862**

(22) Filed: **Jul. 16, 2018**

(65) **Prior Publication Data**

US 2018/0329067 A1 Nov. 15, 2018

Related U.S. Application Data

(63) Continuation of application No. 15/379,854, filed on Dec. 15, 2016, now Pat. No. 10,338,225.

(60) Provisional application No. 62/267,785, filed on Dec. 15, 2015.

(51) **Int. Cl.**
G01S 17/931 (2020.01)
G01S 17/89 (2020.01)
G01S 17/42 (2006.01)
G01S 7/48 (2006.01)

(52) **U.S. Cl.**
CPC **G01S 17/931** (2020.01); **G01S 7/48** (2013.01); **G01S 17/42** (2013.01); **G01S 17/89** (2013.01)

(58) **Field of Classification Search**
None
See application file for complete search history.

(56) **References Cited**

U.S. PATENT DOCUMENTS

5,012,745	A	5/1991	Yamashita	
5,170,458	A	12/1992	Aoyagi	
5,590,604	A	1/1997	Lund	
5,598,783	A	2/1997	Lund	
5,726,647	A	3/1998	Waffler	
6,122,040	A *	9/2000	Arita	B60T 7/22 180/169
6,434,302	B1	8/2002	Fidric	
6,657,705	B2 *	12/2003	Sano	G01S 17/46 356/4.01
6,827,265	B2	12/2004	Knowles	
6,860,350	B2	3/2005	Beuhler	
6,956,227	B2 *	10/2005	Miyazaki	G01S 17/931 250/559.38
7,248,342	B1	7/2007	Degnan	

(Continued)

FOREIGN PATENT DOCUMENTS

CA	3027331	2/2017
CN	102494609	6/2012

(Continued)

OTHER PUBLICATIONS

Notice of Allowance in CA 3,015,894 dated Sep. 14, 2018.

(Continued)

Primary Examiner — Bhavesh V Amin
(74) *Attorney, Agent, or Firm* — Mahamedi IP Law LLP

(57) **ABSTRACT**

A LIDAR sensor for an autonomous vehicle (AV) can include a set of mirrors and a set of lasers outputting laser beams via the set of mirrors. The LIDAR sensor can further include one or more mirror actuators to adjust the set of mirrors, in response to AV feedback from the AV, to reconfigure a beam pattern of the outputted lasers.

19 Claims, 5 Drawing Sheets

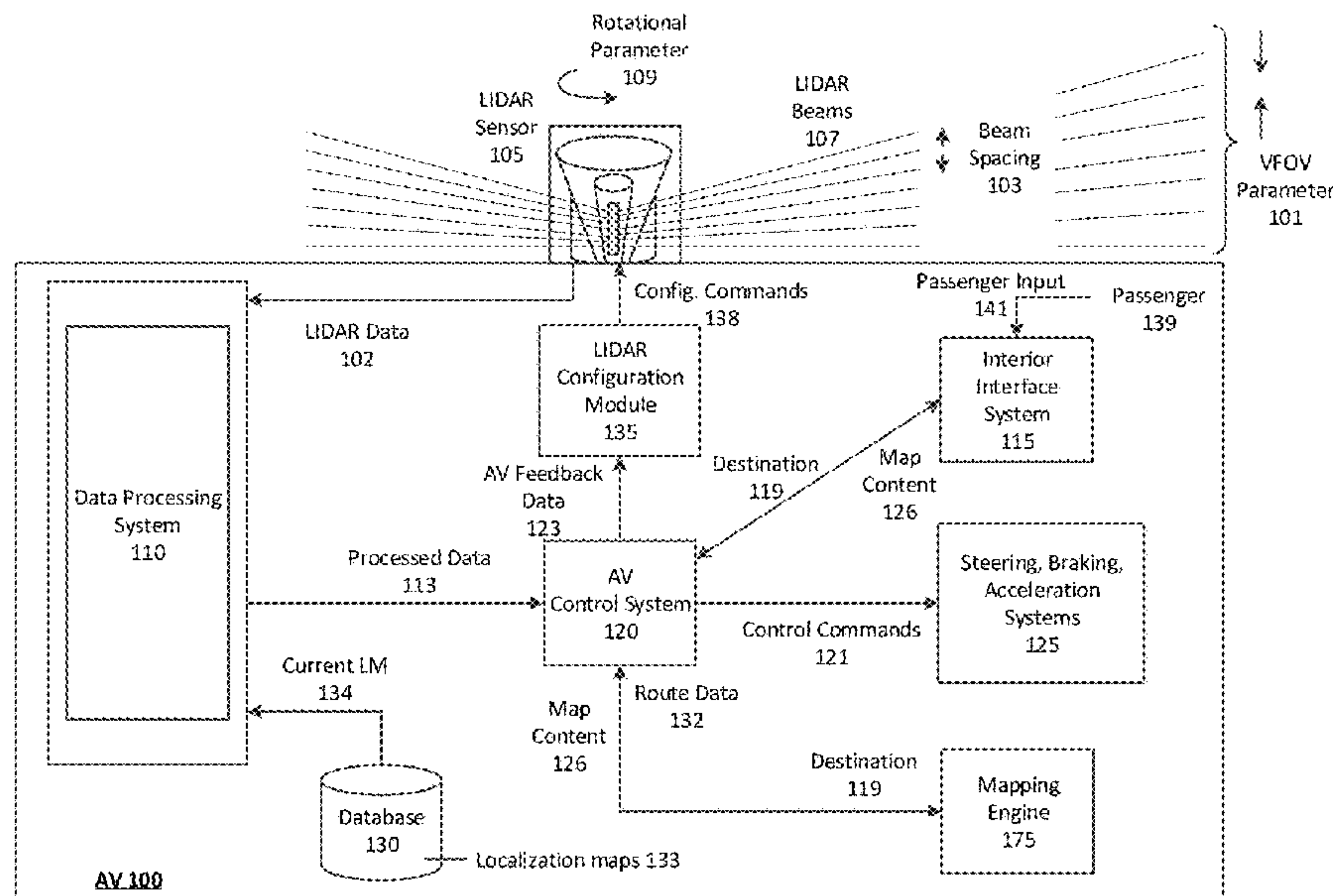

(56)

References Cited

U.S. PATENT DOCUMENTS

7,406,220 B1 *	7/2008	Christensen	G02B 6/032	385/27	2008/0161986 A1	7/2008	Breed	
7,532,311 B2 *	5/2009	Henderson	G01B 11/026	356/28	2008/0215184 A1	9/2008	Choi et al.	
7,650,239 B2	1/2010	Samukawa			2009/0115994 A1 *	5/2009	Stettner	G01S 17/931
7,961,301 B2	6/2011	Earhart						356/5.01
8,208,716 B2	6/2012	Choi et al.			2009/0312906 A1 *	12/2009	Bauer	B60W 40/04
8,344,940 B2	1/2013	Jeong						701/36
8,610,881 B2 *	12/2013	Gammenthaler	G01S 17/88	356/28	2009/0319112 A1	12/2009	Fregene	
8,692,980 B2 *	4/2014	Gilliland	G01S 7/4972	356/5.01	2010/0013615 A1	1/2010	Hebert et al.	
8,736,818 B2 *	5/2014	Weimer	G01C 3/08	250/208.2	2010/0016523 A1	1/2010	Moers	
8,767,186 B2	7/2014	Lu			2010/0020306 A1 *	1/2010	Hall	H01S 5/0428
8,797,828 B1	8/2014	Lev						356/5.01
8,899,903 B1	12/2014	Saad			2010/0053715 A1	3/2010	O'Neill	
8,909,375 B2	12/2014	Larson			2010/0110192 A1	5/2010	Johnston	
8,994,581 B1 *	3/2015	Brown	G01S 13/931	342/83	2010/0165323 A1 *	7/2010	Fiess	G01S 17/931
8,996,224 B1	3/2015	Louie						356/5.01
9,126,595 B2	9/2015	Seo			2010/0182587 A1 *	7/2010	Fluckiger	G01S 17/04
9,201,424 B1	12/2015	Ogale						356/4.01
9,224,053 B1	12/2015	Ferguson			2010/0185353 A1 *	7/2010	Barwick	B62D 7/026
9,228,833 B2	1/2016	Zeng						701/23
9,231,998 B2	1/2016	Lu et al.			2010/0194890 A1	8/2010	Weller	
9,247,211 B2	1/2016	Zhang			2010/0208034 A1	8/2010	Chen	
9,328,526 B2	5/2016	Shani			2010/0208244 A1 *	8/2010	Earhart	G01S 7/4816
9,360,554 B2 *	6/2016	Retterath	G01S 7/4817					356/139.01
9,383,753 B1 *	7/2016	Templeton	G01S 17/86		2011/0050855 A1	3/2011	Nobis et al.	
9,453,914 B2	9/2016	Stettner			2011/0134249 A1	6/2011	Wood	
9,454,150 B2 *	9/2016	Uehara	B60W 50/082		2011/0166757 A1	7/2011	Otanez	
9,529,079 B1	12/2016	Droz			2011/0184605 A1	7/2011	Neff	
9,625,582 B2 *	4/2017	Gruver	G01S 7/4808		2011/0241845 A1	10/2011	Sullivan	
9,637,118 B2	5/2017	Yokota			2011/0245964 A1	10/2011	Sullivan	
9,669,827 B1	6/2017	Ferguson			2011/0301786 A1	12/2011	Allis	
9,696,722 B1	7/2017	Ulrich			2011/0317993 A1	12/2011	Weissler	
9,719,801 B1	8/2017	Ferguson			2012/0008129 A1 *	1/2012	Lu	G01S 17/86
9,720,415 B2	8/2017	Levinson						356/5.01
9,804,264 B2 *	10/2017	Villeneuve	G01S 7/4815		2012/0033196 A1 *	2/2012	Vanek	G06T 17/05
9,823,353 B2	11/2017	Eichenholz						356/4.01
9,840,256 B1	12/2017	Valois			2012/0038903 A1 *	2/2012	Weimer	G01C 3/08
9,841,495 B2	12/2017	Campbell						356/4.07
9,841,763 B1	12/2017	Valois			2012/0044476 A1 *	2/2012	Earhart	G01S 7/4814
9,857,468 B1	1/2018	Eichenholz						356/4.01
9,869,753 B2	1/2018	Eldada			2012/0154785 A1	6/2012	Gilliland	
9,869,754 B1	1/2018	Campbell			2012/0239238 A1	9/2012	Harvey	
9,874,635 B1	1/2018	Eichenholz			2013/0078063 A1	3/2013	Shani	
9,880,263 B2 *	1/2018	Droz	G01S 17/87		2013/0166105 A1	6/2013	Wastel	
9,897,687 B1	2/2018	Campbell			2013/0190963 A1	7/2013	Kuss	
10,338,225 B2 *	7/2019	Boehmke	G01S 17/89		2013/0226431 A1 *	8/2013	Lu	B60W 30/16
2002/0135468 A1	9/2002	Bos et al.						701/96
2004/0030474 A1 *	2/2004	Samuel	B60G 17/0185	701/36	2013/0317649 A1 *	11/2013	Larson	G01S 17/42
2004/0148093 A1	7/2004	Tanaka						700/259
2004/0174537 A1	9/2004	Ferger			2014/0041966 A1	2/2014	Healy	
2005/0095092 A1	5/2005	Segal			2014/0136414 A1	5/2014	Abhyanker	
2005/0185846 A1	8/2005	Luo			2014/0168631 A1	6/2014	Haslim	
2005/0196015 A1	9/2005	Luo			2014/0176933 A1	6/2014	Haslim	
2005/0196035 A1	9/2005	Luo			2014/0231647 A1	8/2014	Chinn	
2006/0089765 A1 *	4/2006	Pack	G05D 1/0061	701/23	2014/0277691 A1	9/2014	Jacobus	
2006/0149134 A1	7/2006	Soper			2014/0286744 A1	9/2014	Shani	
2006/0158423 A1	7/2006	Kern			2015/0025731 A1 *	1/2015	Uehara	B60W 50/082
2006/0227317 A1 *	10/2006	Henderson	G01B 11/026	356/28				701/23
2007/0200064 A1	8/2007	Remillard			2015/0091374 A1	4/2015	Lenius	
2007/0212006 A1	9/2007	Wysocki			2015/0202939 A1	7/2015	Stettner	
2007/0219720 A1 *	9/2007	Trepagnier	B60W 30/095	701/300	2015/0293225 A1	10/2015	Riley	
2008/0002427 A1	1/2008	Kropac			2015/0293228 A1 *	10/2015	Retterath	G01S 17/931
2008/0039991 A1	2/2008	May						356/5.01
2008/0136626 A1 *	6/2008	Hudson	G01S 17/86	340/540	2015/0334269 A1	11/2015	Yokota	
					2016/0003946 A1	1/2016	Gilliland	
					2016/0129917 A1	5/2016	Garipey	
					2016/0223671 A1	8/2016	Thayer	
					2016/0227193 A1	8/2016	Osterwood	
					2016/0231746 A1	8/2016	Hazelton et al.	
					2016/0282468 A1	9/2016	Gruver	
					2016/0291134 A1 *	10/2016	Droz	G01S 17/87
					2016/0318415 A1	11/2016	Salasoo	
					2016/0349746 A1	12/2016	Grau	
					2017/0096138 A1	4/2017	Reiff	
					2017/0155225 A1 *	6/2017	Villeneuve	G01S 17/42
					2017/0168146 A1 *	6/2017	Boehmke	G01S 7/48
					2017/0184399 A1	6/2017	Thayer	
					2017/0226765 A1	8/2017	Wastel	
					2017/0255199 A1	9/2017	Boehmke	

(56)

References Cited

U.S. PATENT DOCUMENTS

2017/0357260	A1	12/2017	Gilliland
2018/0070804	A1	3/2018	Tesar
2018/0149732	A1	5/2018	Droz
2018/0329067	A1*	11/2018	Boehmke G01S 7/48
2019/0146505	A1	5/2019	Boehmke
2019/0235054	A1	8/2019	Ratner

FOREIGN PATENT DOCUMENTS

CN	101959022	11/2012
CN	103152518	6/2013
CN	103179339	6/2013
CN	203353019	12/2013
CN	104133473	11/2014
CN	103001428	5/2015
CN	102857592	12/2015
CN	204990755	1/2016
CN	103146355	2/2016
CN	106313078	1/2017
CN	207908673	9/2018
DE	10244638	4/2004
EP	0185816	7/1986
EP	2940489	11/2015
EP	1816514	8/2017
JP	H09163197	12/1998
JP	H09326032	6/1999
JP	2011088623	4/2001

JP	2005024463	1/2005
JP	2007249632	9/2007
JP	2008104254	5/2008
JP	2011123078	12/2010
RU	2493988	9/2013
RU	2012154453	6/2014
RU	2014146890	6/2016
WO	WO 2011/104706	9/2011
WO	PCT/JP2014/053408	3/2014

OTHER PUBLICATIONS

Examination Report No. 1 in AU 2017225790 dated Sep. 3, 2018.
 EESR in EP 17760835.3 dated May 2, 2019.
 ISR and Written Opinion in PCT/US2019/015882 dated May 16, 2019.
 Office Action in EP 14770009.0 dated Apr. 24, 2019.
 ISR and Written Opinion in PCT/US2017/020483 dated Jun. 29, 2017.
 IPRP in PCT/2017/020483 dated Sep. 13, 2018.
 ISR and Written Opinion in PCT/US2018/023885 dated Aug. 16, 2018.
 PESR in EP 17760835.3 dated Jan. 24, 2019.
 Office Action in CN201480022190.5 dated Aug. 22, 2017.
 Office Action in CA2,902,430 dated Dec. 15, 2017.
 Office Action in JP 2016-502343 dated Jan. 18, 2018.
 Office Action in CN 201780022918.8 dated Aug. 16, 2019.
 Office Action in CN 201780022918.8 dated Feb. 21, 2020.

* cited by examiner

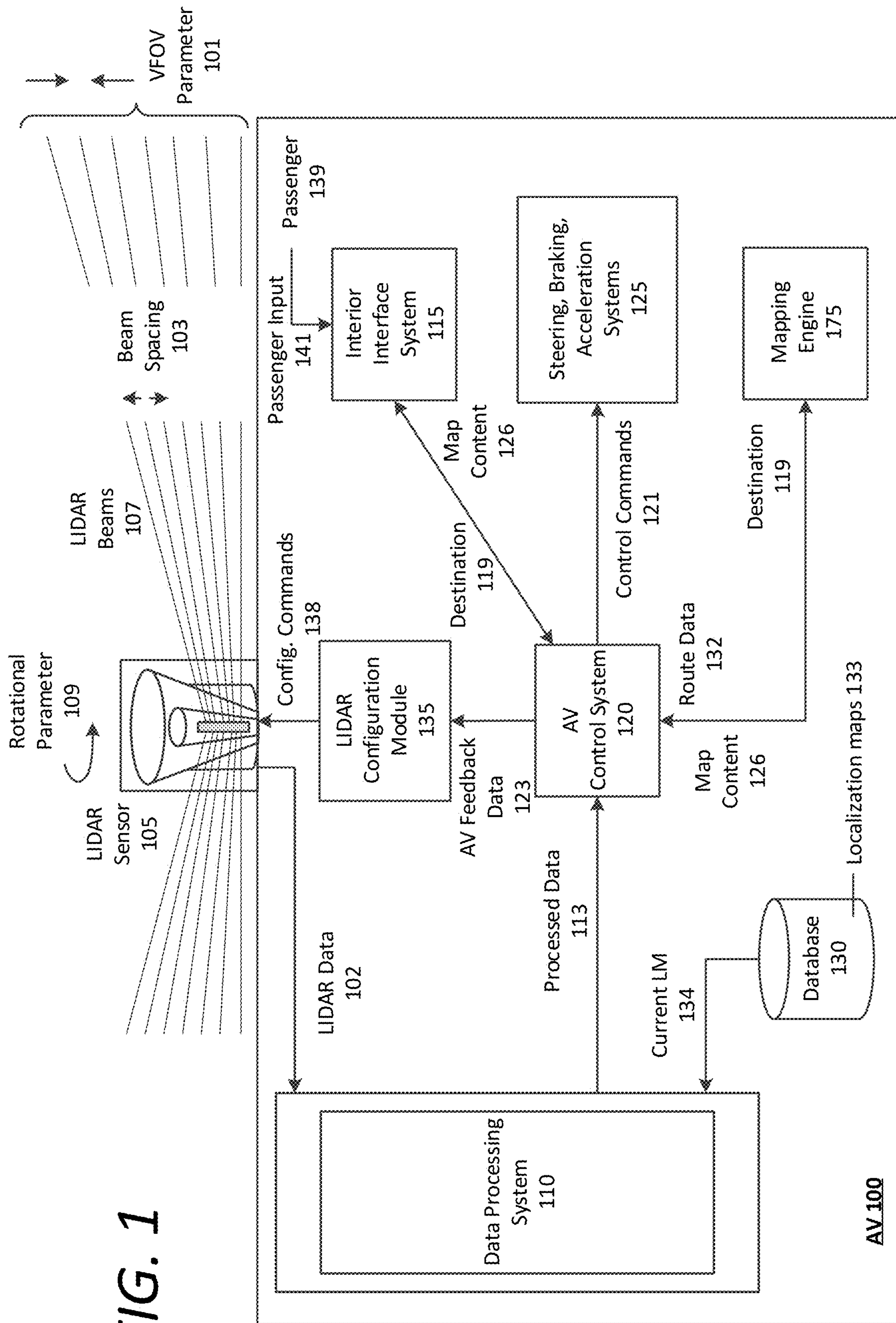

FIG. 1

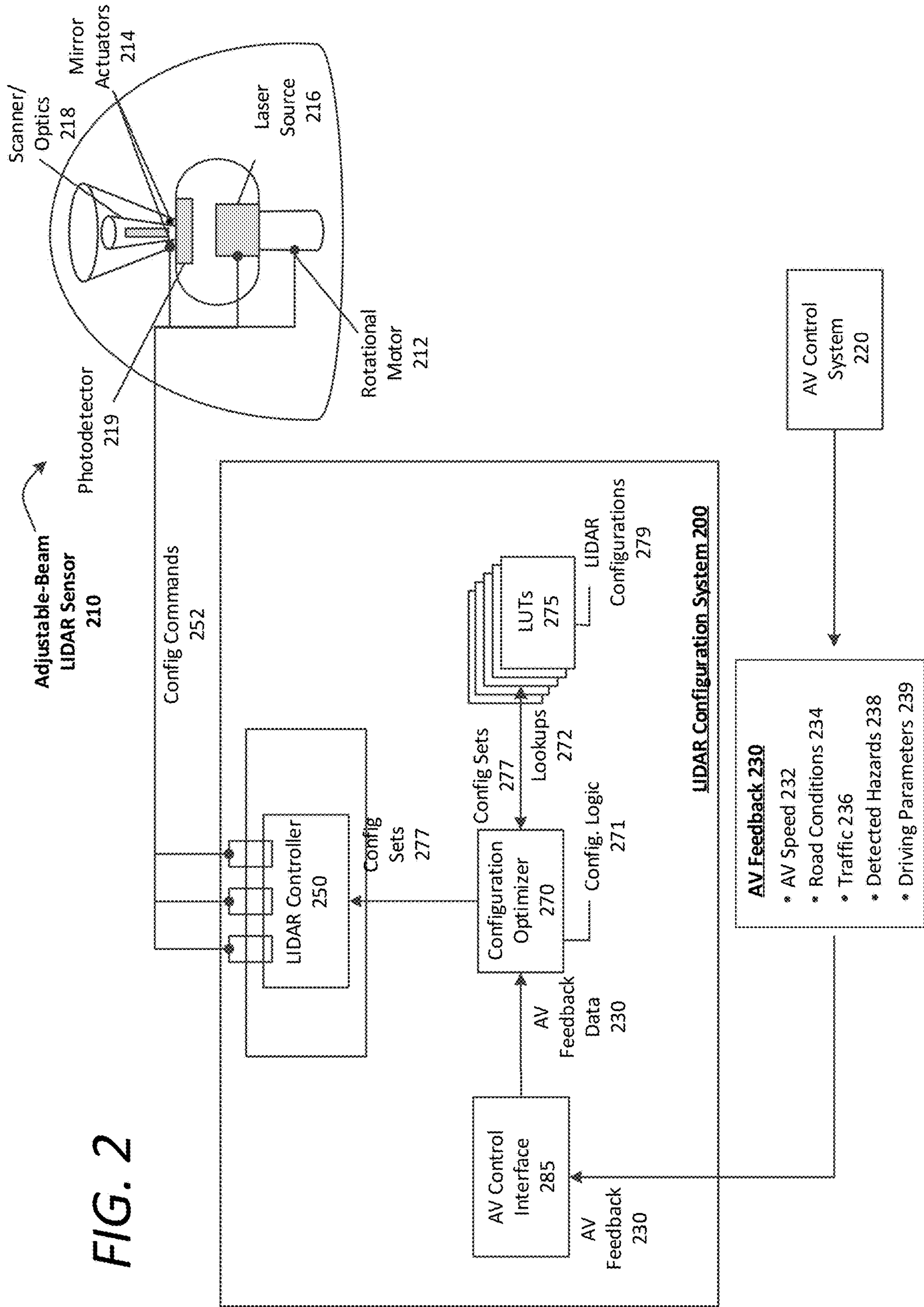

FIG. 2

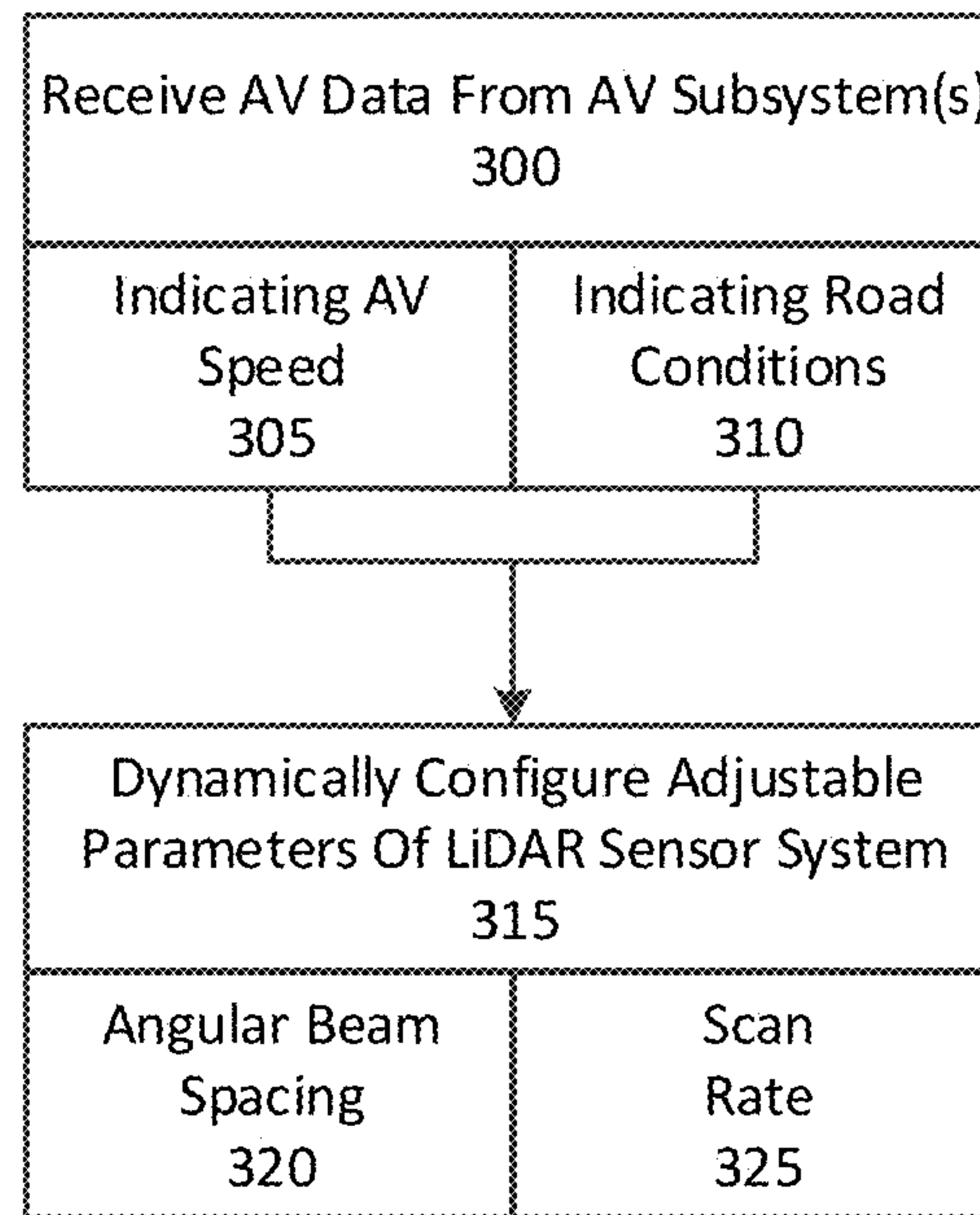

FIG. 3

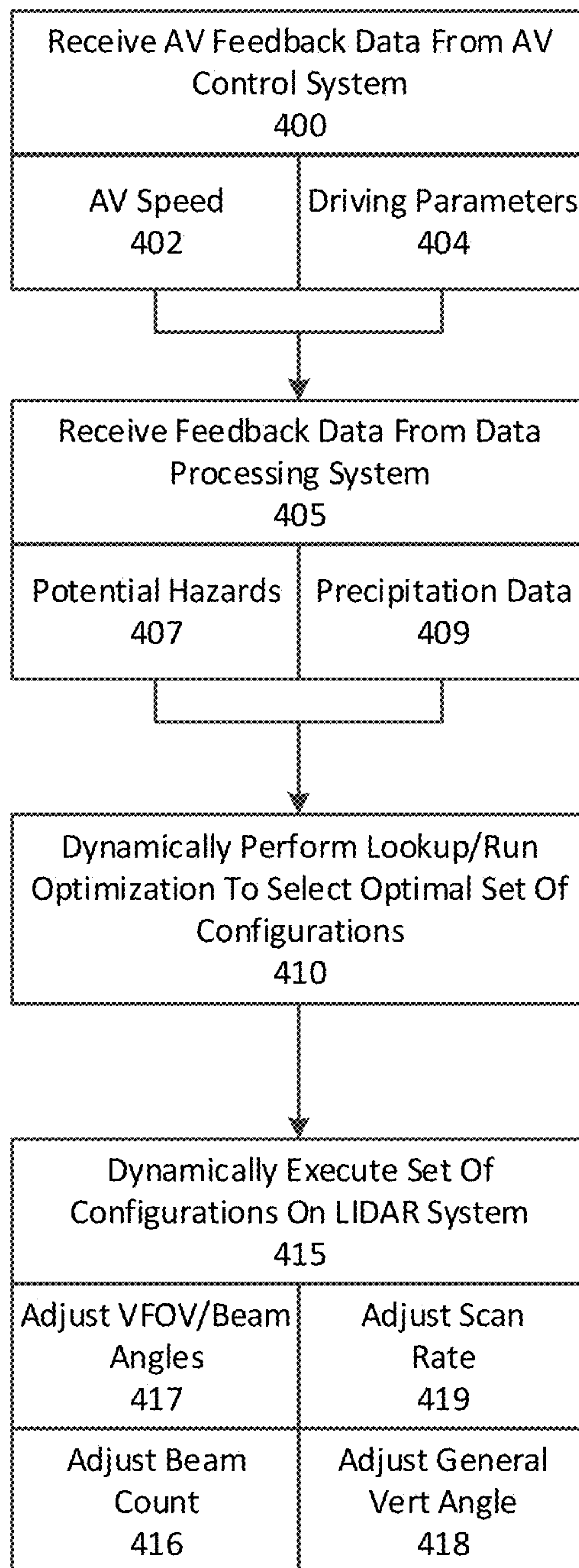

FIG. 4

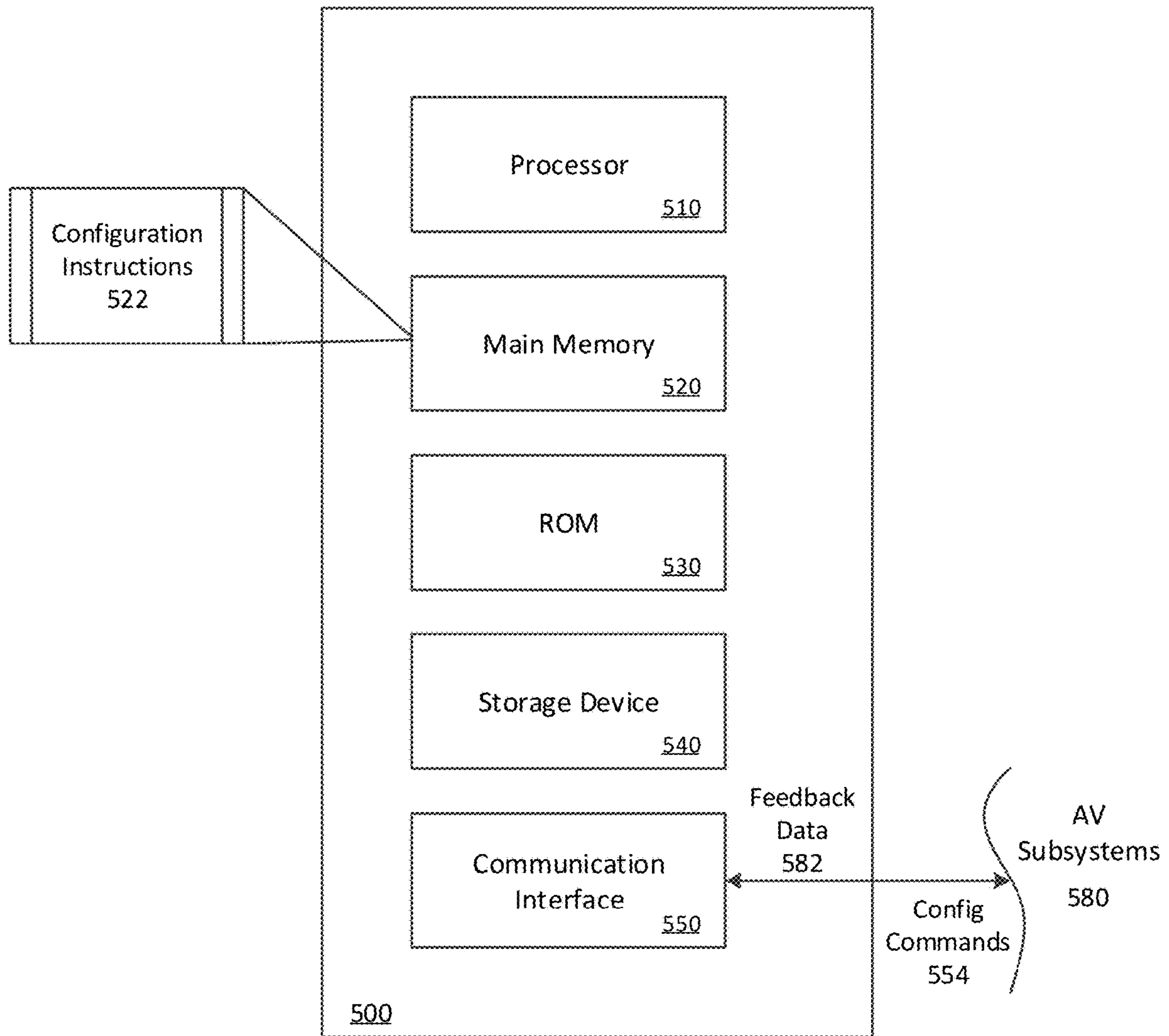

FIG. 5

ADJUSTABLE BEAM PATTERN FOR LIDAR SENSOR

CROSS-REFERENCE TO RELATED APPLICATIONS

This application is a Continuation of U.S. patent application Ser. No. 15/379,854, filed on Dec. 15, 2016; which claims the benefit of U.S. Provisional Patent Application No. 62/267,785, filed Dec. 15, 2015; the aforementioned applications being hereby incorporated by reference in their respective entireties.

BACKGROUND

Automated or autonomous vehicles (AVs) may require continuous processing of sensor data provided by an on-board laser imaging, detection, and ranging (LIDAR) sensor system. For fixed-beam LIDAR systems, the granularity for detected objects, such as obstacles and potential road hazards, becomes increasingly coarser in relation to distance.

BRIEF DESCRIPTION OF THE DRAWINGS

The disclosure herein is illustrated by way of example, and not by way of limitation, in the figures of the accompanying drawings in which like reference numerals refer to similar elements, and in which:

FIG. 1 is a block diagram illustrating an example AV including a LIDAR sensor configuration module, as described herein;

FIG. 2 is a block diagram illustrating an example LIDAR sensor configuration system utilized in connection with a LIDAR sensor, as described herein;

FIG. 3 is a high level flow chart describing an example method of dynamically configuring a LIDAR sensor;

FIG. 4 is a low level flow chart describing an example method of configuring a LIDAR sensor, as described herein; and

FIG. 5 is a block diagram illustrating an example computing system upon which examples described herein may be implemented.

DETAILED DESCRIPTION

Current LIDAR technology include fixed-beam LIDAR systems that include laser sources, scanners, optical systems (e.g., a beam splitter), and photodetectors. For example, cutting edge LIDAR systems can include pulse rates on the order of one million pulses per second producing a detailed point cloud map of an AV's surroundings at ranges upwards of one hundred-plus meters. When using typical fixed-beam LIDAR systems for AVs traveling through road traffic, operational speed may be limited by the nature of the beam pattern produced by the LIDAR system. For example, in order to ensure safety for an AV traveling at 15 miles per hour (mph), the LIDAR system may require at least twelve separate beams to readily detect potential hazards with sufficient granularity and decelerate, maneuver, and/or stop the AV accordingly. However, when the AV travels at a very high speed (e.g., 60 mph, 75 mph, etc.), in order to achieve the same granularity for potential hazards in order to safely react, decelerate, and/or stop the AV, a fixed-beam LIDAR system may require well over seventy separate beams.

Increasing the number of fixed beams also places additional requirements for the LIDAR system. For example, the LIDAR will require more power, greater processing capa-

bility, larger or more sensitive photodetector and receiving equipment, constrained optics, and generally greater weight and more space. Furthermore, cost and waste quickly become an issue when increasing the number of fixed-beams, since the fixed-beam pattern or the fixed-beam LIDAR system must be tuned for a maximum operational speed of the AV. If AVs are going to operate safely with LIDAR technology on public highways at high speed, then alternative arrangements may be necessary to avoid spiraling costs, wasted power, additional equipment, and increased processing requirement.

To address the shortcomings of various fixed-beam LIDAR systems, a LIDAR sensor configuration system is provided with an adjustable-beam LIDAR sensor to control various adjustable parameters of the LIDAR sensor while an AV travels on a given road. The LIDAR configuration system can include a sensor controller that executes sensor configuration logic to adjust the configurable parameters in response to AV feedback from, for example, a control system of the AV. The configurable parameters of the LIDAR sensor can include a beam pattern (e.g., provided by a light source of the LIDAR), such as a vertical beam pattern that adjusts a vertical field of view of the LIDAR sensor. The configurable parameters can also include a rotational speed of the LIDAR system, a scan rate, a pulse rate, a beam frequency (e.g., a visible versus an infrared laser frequency), a photodetector sensitivity, and the like. The feedback data provided to the LIDAR configuration system can include a current speed of the AV, road conditions (e.g., type of road, road wetness, potholes, etc.), weather conditions (e.g., whether precipitation is detected), traffic conditions, pedestrian activity, road geometry (e.g., advance knowledge of road curves, gradients, etc. using a map or sensor data from the LIDAR itself) driving parameters (e.g., a turn rate, acceleration and/or braking of the AV), and the like.

According to examples described herein, the LIDAR configuration system can receive the feedback data from a control system of the AV, where the control system operates the steering, acceleration, and braking systems. Additionally or alternatively, the LIDAR configuration system can receive feedback as sensor data directly from a sensor array (e.g., LIDAR data from the LIDAR itself). In variations, the LIDAR configuration system can receive feedback data from an on-board computing system, such as a data processing system, of the AV. The LIDAR configuration system can respond to the feedback data by adjusting any number of the adjustable parameters of the LIDAR sensor.

For example, the LIDAR configuration system can dynamically adjust a vertical angular spacing between each beam based on the speed of the AV. Specifically, the LIDAR configuration system can dynamically increase the vertical angular spacing of the beams as the AV decreases speed, and dynamically decrease the vertical angular spacing of the beams as the AV increases speed. In many aspects, the LIDAR sensor system can include components having adjustable parameters, such as a rotational motor that can be adjusted to control a scan rate or horizontal sweep rate of the beam pattern, and mirror actuators that can be adjusted to control the vertical field of view or vertical sweep of the beam pattern. Each of these components can be dynamically adjusted by the LIDAR configuration system in response to the feedback from the AV.

As another example, precipitation can significantly reduce the effectiveness of the LIDAR sensor to detect potential road hazards. As such, the AV control system may operate the AV in a high-caution mode, reducing speed, increasing processing power, and maintaining large gaps between the

AV and any potential hazard. In certain implementations, the LIDAR configuration system can also operate in a high-caution mode by, for example, increasing a scan rate, and adjusting the horizontal and vertical sweep pattern of the LIDAR sensor to provide more detailed data for the AV's on-board data processing system.

In some aspects, the optics of the LIDAR may be such that a general vertical angle of the beams may be adjusted, in addition to the vertical spacing between the beams. For example, the feedback data can include a road gradient of the current road traveled by the AV (e.g., a mapping resource can indicate that the road immediately in front of the AV curves upwardly). The LIDAR configuration system can compensate for the upward gradient of the road by adjusting the general vertical beam angle of the LIDAR sensor. That is, in addition to adjusting the angular spacing between beams, every beam may be also angled to adjust for the forward road gradient indicated in the feedback data. In certain implementations, the general angle may be adjusted to align with the detected angle, and may be limited based on the speed of the AV.

For example, National Highway Traffic and Safety Administration (NHTSA) regulations exist for public roads that correlate road speed with road gradient and gradient transitions. For example, the greater the speeds, the lower the gradient transition or curve of the road. According to certain aspects, the LIDAR configuration dynamically set boundaries for the general vertical angle of the beam pattern based on the speed of the AV, and in accordance with the NHTSA regulations, since the LIDAR configuration system can expect, with certainty, that the gradient will not increase or decrease beyond a certain rate.

In addition to the adjustable-beam LIDAR systems described herein, a fixed-beam LIDAR system is disclosed having optimized, uneven beam spacing for a wide variety of travel conditions. The fixed-beam LIDAR system can be calibrated to provide optimal beam spacing for short, medium, and long distance range, all in one set of lasers. In one example, the beam angles can progressively decrease or converge along the length of the laser configuration (e.g., from the bottom to top). In variations, the beam angles can be optimally calibrated and configured individually. For example, the beam angles can be individually calibrated based on distance, anticipated speeds, vehicle dynamics, typical road gradients, and the like, and can comprise uneven beam spacing for optimal use in a wide variety of environments (e.g., urban scenarios and well as open, rural roads). In further variations, a combination of fixed-beam and adjustable beam laser configuration can be implemented in LIDAR sensors described herein.

Among other benefits, the examples described herein achieve a technical effect of providing adjustability for LIDAR sensors in order to increase data quality, reduce costs, reduce processing requirements, and reduce the number of beams necessary for typical road travel for AVs.

As used herein, the AV's LIDAR system implements remote sensing using laser beams, which can include diode lasers, fiber lasers, and the like. "LIDAR" is used herein as a representation of any light detection and ranging systems utilized on an AV. Such systems may be referred to as "LIDAR" or "LADAR" systems. For the sake of brevity, "LIDAR" is used throughout to represent any of such systems should distinctions be made in the common nomenclature for future reference.

As used herein, a computing device refer to devices corresponding to desktop computers, cellular devices or smartphones, personal digital assistants (PDAs), field pro-

grammable gate arrays (FPGAs), laptop computers, tablet devices, television (IP Television), etc., that can provide network connectivity and processing resources for communicating with the system over a network. A computing device can also correspond to custom hardware, in-vehicle devices, or on-board computers, etc. The computing device can also operate a designated application configured to communicate with the network service.

One or more examples described herein provide that methods, techniques, and actions performed by a computing device are performed programmatically, or as a computer-implemented method. Programmatically, as used herein, means through the use of code or computer-executable instructions. These instructions can be stored in one or more memory resources of the computing device. A programmatically performed step may or may not be automatic.

One or more examples described herein can be implemented using programmatic modules, engines, or components. A programmatic module, engine, or component can include a program, a sub-routine, a portion of a program, or a software component or a hardware component capable of performing one or more stated tasks or functions. As used herein, a module or component can exist on a hardware component independently of other modules or components. Alternatively, a module or component can be a shared element or process of other modules, programs or machines.

Some examples described herein can generally require the use of computing devices, including processing and memory resources. For example, one or more examples described herein may be implemented, in whole or in part, on computing devices such as servers, desktop computers, cellular or smartphones, personal digital assistants (e.g., PDAs), laptop computers, printers, digital picture frames, network equipment (e.g., routers) and tablet devices. Memory, processing, and network resources may all be used in connection with the establishment, use, or performance of any example described herein (including with the performance of any method or with the implementation of any system).

Furthermore, one or more examples described herein may be implemented through the use of instructions that are executable by one or more processors. These instructions may be carried on a computer-readable medium. Machines shown or described with figures below provide examples of processing resources and computer-readable mediums on which instructions for implementing examples disclosed herein can be carried and/or executed. In particular, the numerous machines shown with examples of the invention include processor(s) and various forms of memory for holding data and instructions. Examples of computer-readable mediums include permanent memory storage devices, such as hard drives on personal computers or servers. Other examples of computer storage mediums include portable storage units, such as CD or DVD units, flash memory (such as carried on smartphones, multifunctional devices or tablets), and magnetic memory. Computers, terminals, network enabled devices (e.g., mobile devices, such as cell phones) are all examples of machines and devices that utilize processors, memory, and instructions stored on computer-readable mediums. Additionally, examples may be implemented in the form of computer-programs, or a computer usable carrier medium capable of carrying such a program.

System Description

FIG. 1 is a block diagram illustrating an example AV 100 including a LIDAR sensor configuration module 135, as described herein. The AV 100 can include an adjustable-

beam LIDAR sensor **105** that can provide LIDAR data **102** to an on-board data processing system **110** of the AV **100**. In some examples, the LIDAR sensor **105** can comprise a light source (e.g., a laser), a photodetector, scanner components (e.g., which can include a mirror(s), one or more motor(s), and one or more actuator(s)), and circuitry to couple to various components of the AV **100**. The data processing system **110** can utilize the LIDAR data **102** to detect the situational conditions of the AV **100** as the AV **100** travels along a current route. For example, the data processing system **110** can identify potential obstacles or road hazards—such as pedestrians, bicyclists, objects on the road, road cones, road signs, animals, etc.—in order to enable an AV control system **120** to react accordingly.

In certain implementations, the data processing system **110** can utilize localization maps **133** stored in a database **130** of the AV **100** in order to perform localization and pose operations to determine a current location and orientation of the AV **100** in relation to a given region (e.g., a city). The localization maps **133** can comprise previously recorded sensor data, such as stereo camera data, radar maps, and/or LIDAR maps that enable the data processing system **110** to compare the LIDAR data **102** from the LIDAR sensor **105** with a current localization map **134** to identify such obstacles and potential road hazards in real time. The data processing system **110** can provide the processed sensor data **113**—identifying such obstacles and road hazards—to AV control system **120**, which can react accordingly by operating the steering, braking, and acceleration systems **125** of the AV **100**.

In many implementations, the AV control system **120** can receive a destination **119** from, for example, an interior interface system **115** of the AV **100**. The interior interface system **115** can include any number of touch-screens or voice sensors that enable a passenger **139** to provide a passenger input **141** indicating the destination **119**. For example, the passenger **139** can type the destination **119** into a mapping engine **175** of the AV **100**, or can speak the destination **119** into the interior interface system **115**. Additionally or alternatively, the destination **119** can be received by the AV **100** as a communication from a backend system that manages routes for a fleet of AVs. The backend system can be operative to facilitate passenger pick-ups and drop-offs to generally service pick-up requests, facilitate delivery such as packages, food, goods, or animals, and the like.

Based on the destination **119** (e.g., a pick-up location), the AV control system **120** can utilize the mapping engine **175** to receive route data **132** indicating a route to the destination **119**. In variations, the mapping engine **175** can also generate map content **126** dynamically indicating the route traveled to the destination **119**. The route data **132** and/or map content **126** can be utilized by the AV control system **120** to maneuver the AV **100** to the destination **119** along the selected route. For example, the AV control system **120** can dynamically generate control commands **121** for the AV's steering, braking, and acceleration system **125** to actively drive the AV **100** to the destination **119** along the selected route. Optionally, the map content **126** showing the current route traveled can be streamed to the interior interface system **115** so that the passenger(s) **139** can view the route and route progress in real time.

In many examples, while the AV control system **120** operates the steering, braking, and acceleration systems **125** along the current route on a high level, the processed data **113** provided to the AV control system **120** can indicate low level occurrences, obstacles, and potential hazards to which the AV control system **120** can react. For example, the

processed data **113** can indicate a pedestrian crossing the road, traffic signals, stop signs, other vehicles, road conditions, traffic conditions, bicycle lanes, crosswalks, pedestrian activity (e.g., a crowded adjacent sidewalk), and the like. The AV control system **120** can respond to the processed data **113** by generating control commands **121** to reactively operate the steering, braking, and acceleration systems **125** accordingly.

According to examples described herein, the AV **100** can include a LIDAR configuration module **135** to receive AV feedback data **123** from the AV control system **120** in order to configure various adjustable parameters of the LIDAR sensor **105**. The AV feedback data **123** can include data indicating the current speed of the AV **100**, any of the described obstacles and/or potential hazards, weather conditions identified by the data processing system **110** (e.g., rain or snow), forward road features (e.g., an imminent gradient of the road), traffic conditions, a turn rate and/or an acceleration rate, and the like.

The LIDAR configuration module **135** can respond to the AV feedback data **123** by adjusting one or more adjustable parameters of the LIDAR sensor **105**. For example, the LIDAR configuration module **135** can generate configuration commands **138** in response to the AV feedback data **123** to adjust a rotational parameter **109** of the LIDAR sensor **105** (e.g., the rotational speed of the motor), a vertical field of view (VFOV) parameter **101** of the LIDAR sensor **105**, a number of emitted LIDAR beams **107** by the LIDAR sensor **105**, and/or a beam spacing **103** or angular spacing between the LIDAR beams **107** themselves.

One or more components of the LIDAR sensor **105** can comprise non-mechanical aspects that cause the LIDAR beams **107** to adjust their beam angles in response to autonomous driving characteristics by the AV control system **120**, such as vehicle velocity, acceleration, braking inputs, steering inputs, and the like. In one aspect, the angle of the LIDAR beam **107** may be wholly adjusted non-mechanically, or may be adjusted through a combination of mechanical and non-mechanical features. In variations, the LIDAR configuration module **135** can generate configuration commands **138** that are executable on mechanical components of the LIDAR sensor **105** to adjust the beam spacing **103** of the LIDAR beams **107** in response to the AV feedback data **123**.

As an example, when the AV **100** is traveling at low speeds, the LIDAR configuration module **135** can dynamically increase the angular beam spacing **103** between the LIDAR beams **107** since (i) the reaction and stopping distances are much lower at low speeds, and (ii) an increased VFOV may be necessary to detect objects close to the AV **100**. Conversely, when the AV **100** accelerates to higher speeds, the LIDAR configuration module **135** can dynamically narrow the VFOV parameter **101**, decreasing the angular beam spacing **103**, since (i) the reaction and stopping distances increase, thereby requiring finer granularity in the LIDAR data **102** to detect objects further down the road, (ii) a decreased field of view may be suitable for increased speeds since more proximate objects can be detected earlier, and (iii) at higher speeds, NHTSA guidelines specify road geometries that make decreased field of view suitable. Detailed discussion is provided with regard to the LIDAR configuration module **135** with respect to FIG. 2 below.

FIG. 2 is a block diagram illustrating an example LIDAR sensor configuration system **200** utilized in connection with an adjustable-beam LIDAR sensor **210**, as described herein. The LIDAR configuration system **200** may be implemented as a component of the AV **100** described in connection with FIG. 1. Furthermore, the LIDAR configuration system **200**

shown and described with respect to FIG. 2, can include the same or similar functionality as the LIDAR configuration module 135 shown and described with respect to FIG. 1. Referring to FIG. 2, the LIDAR configuration system 200 can include an AV control interface 285 to receive the AV feedback data 230 from the AV control system 220. As described herein, the AV feedback data 230 can include various aspects of the AV's speed 232, the road conditions 234 (e.g., road gradient, wet versus dry conditions, lane count, etc.), traffic conditions 236 (e.g., light, moderate, or heavy traffic), detected hazards 238 (e.g., identified pedestrians, bicyclists, road objects, etc.), and/or driving parameters 239 (e.g., acceleration rate, braking rate, and/or turning rate).

Furthermore, as provided herein, the LIDAR configuration system 200 is shown as a standalone module for illustrative purposes. However, various functions of the LIDAR configuration system 200 may be performed by separate processing components of the AV 100 itself. For example, one or more of the data processing system 110, the AV control system 120, or one or more sensor processor(s) contained within the sensor system itself (e.g. the adjustable beam LIDAR sensor 210 shown in FIG. 2) can perform any number of functions or actions described in connection with the LIDAR configuration system 200. Additionally, any of the various commands transmitted between the blocks shown in FIG. 2 may be transmitted and received via a computer network either wirelessly or via wired communication.

The AV control interface 285 can provide the AV feedback data 230 to a configuration optimizer 270 which can process the AV feedback data 230 to optimize the LIDAR configurations for the LIDAR sensor 210 accordingly. In certain examples, the configuration optimizer 270 can execute configuration logic 271 to perform a lookup 272 in a number of lookup tables (LUTs 275) to select an optimal set of configurations 277 from any number of LIDAR configurations 279 logged or chronicled in the LUTs 275. In variations, the configuration optimizer 270 can execute the configuration logic 271 to dynamically determine the optimal set of configurations 277 to be executed by a LIDAR controller 250 of the LIDAR configuration system 200. The dynamically determined configuration sets 277 can consequently be dynamically executed by the LIDAR controller 250 to generate the configuration commands 252 that actively adjust the configurable parameters of the LIDAR sensor 210.

As provided herein, the dynamically executed set of configurations 277 can cause the LIDAR controller to generate configuration commands 252 that operate on adjustable parameters of the LIDAR sensor 210, such as a rotational motor 212 that controls a rotational rate of the LIDAR beams and/or a scan rate of the LIDAR scanner 218. The LIDAR controller 250 can further generate configuration commands 252 that adjust a pulse rate and/or frequency of the laser by tuning a laser source 216 of the LIDAR sensor 210. For example, the LIDAR controller 250 can increase or decrease power to the laser source 216, increase or decrease the pulse rate (e.g., to increase or decrease granularity of the point cloud), and/or modulate the frequency of the beams themselves (e.g., modifying the reflectance parameters of the LIDAR sensor 210).

In many aspects, the LIDAR controller 250 can generate configuration commands 252 to operate mirror actuators 214 of the LIDAR sensor 210 which, in turn, can adjust the VFOV of the LIDAR sensor 210. Specifically, the LIDAR controller 250 can increase or decrease the VFOV of the

LIDAR sensor 210 by operating the mirror actuators 214 in response to the speed of the AV. In some aspects, the mirror actuators 214 can split the emitted beams between positive VFOV beams, which detect the AV environment above a sensor plane parallel to the road, and negative VFOV beams, which detect the AV environment below the sensor plane. In response to the AV feedback data 230 the configuration optimizer 270 may generate and/or select a configuration set 277 that causes the LIDAR controller 250 to adjust a vertical beam pattern of the LIDAR sensor 210 for the positive VFOV beams differently in comparison to the negative VFOV beams. For example, when the AV is stopped at a stop light in a dense pedestrian environment, the configuration optimizer 270 may select a more spread out negative VFOV beam pattern to identify potential hazards within a much broader VFOV (e.g., a child standing next to the AV).

Examples described herein are not limited to mirror embodiments having mirror actuators. It is contemplated that VFOV adjustments can be made with adjustable beam splitters, directional laser apertures, or adjustable dual oscillating mirrors and/or polygonal mirrors. As an example, an adjustable laser grating of a LIDAR sensor 210 can be configured to dynamically adjust the vertical sweep of the beam pattern by compressing or spreading the angular spacing of the beams.

The LIDAR sensor 210 can further include a scanner and optics system 218 which can be configurable by the LIDAR controller 250. For example, the configuration optimizer 270 can select a set of configurations 277 that cause the scanner and optics system 218 to increase a scan rate in response to detecting precipitation. The increased scan rate can be executed in conjunction with, for example, the AV control system operating in a high-caution mode. Additionally, the LIDAR sensor 210 can include a photodetector 219 which, in certain aspects, can be voltage-adjustable for increased or decreased sensitivity.

Examples described herein improve upon current LIDAR technology by providing a LIDAR configuration system 200 that can dynamically configure the adjustable parameters of the AV's LIDAR sensor 210 in response to AV feedback 230 received from the AV control system 220 and/or other subsystems of the AV. In many aspects, the LIDAR configuration system 200 can dynamically adjust a vertical sweep pattern of the LIDAR sensor 210 by adjusting the angle, or the angular spacing between the beams. By adjusting the VFOV of the LIDAR sensor 210, the LIDAR configuration system 200 can require less beams than current fixed-beam systems, reducing costs and increasing data quality for the AV's on-board data processing system.

Methodology

FIG. 3 is a high level flow chart describing an example method of dynamically configuring a LIDAR sensor. In the below discussion of FIG. 3, reference may be made to like reference characters representing like features as shown and described with respect to FIGS. 1 and 2. For example, the high level method described with respect to FIG. 3 may be performed by an example LIDAR configuration module 135 shown and described with respect to FIG. 1, or the LIDAR configuration system 200 shown and described with respect to FIG. 2. Referring to FIG. 3, the LIDAR configuration system 200 can receive AV data 230 from subsystems of the AV 100, such as the AV control system 120 or the data processing system 110 (300). The AV data 230 can include information such as the AV's speed (305), and road condi-

tions (310) which can indicate potential hazards as the AV 100 travels along a current route.

In response to the AV data 230, the LIDAR configuration system 200 can dynamically configure the adjustable parameters of the LIDAR sensor system 210 of the AV 100 (315). For example, the LIDAR configuration system 200 can dynamically adjust an angular beam spacing between the beams to control a VFOV (320) based on the speed of the AV 100. As another example, the LIDAR configuration system 200 can control a scan rate of the LIDAR sensor system 210 in response to the road conditions (325).

FIG. 4 is a low level flow chart describing an example method of configuring a LIDAR sensor, as described herein. In the below discussion of FIG. 4, reference may be made to like reference characters representing like features as shown and described with respect to FIGS. 1 and 2. For example, the low level method described with respect to FIG. 4 may be performed by an example LIDAR configuration module 135 shown and described with respect to FIG. 1, or the LIDAR configuration system 200 shown and described with respect to FIG. 2. Referring to FIG. 4, the LIDAR configuration system 200 can receive AV feedback data 230 from the AV control system 120 (400). The AV feedback data 230 from the AV control system 120 can include the current AV speed (402) and/or driving parameters of the AV 100 (404).

In certain implementations, the AV feedback data 230 can also be received from the data processing system 110 of the AV 100 (405). This data may include potential hazards on the road (407) and/or precipitation data (409). Based on the received feedback data 230 from the AV control system 120 and the on-board data processing system 110, the LIDAR configuration system 200 can dynamically perform a lookup 272 in a set of LUTs 275 or perform an optimization to select a set of configurations 277 for the LIDAR sensor system 210 (410). The LIDAR configuration system 200 may then dynamically execute the set of configurations 277 on the LIDAR system 210 (415).

In many aspects, execution of the configuration set 277 causes the LIDAR configuration system 200 to adjust a VFOV or the beams angles of the LIDAR sensor system 210 (417). Additionally or alternatively, the configuration set 277 can cause the LIDAR configuration system 200 to adjust a scan rate (419) and/or a beam count (416) for the LIDAR sensor system 210. In still other aspects, the LIDAR configuration system 200 can adjust a general vertical angle of the beams in response to detecting a road gradient (418).

Hardware Diagram

FIG. 5 is a block diagram that illustrates a computer system upon which examples described herein may be implemented. A computer system 500 can be implemented on, for example, a server or combination of servers. For example, the computer system 500 may be implemented as part of a LIDAR configuration system 135, which itself may be implemented as a part of the AV's on-board data processing system 110. In the context of FIG. 1, the LIDAR configuration system 135 may include a sensor controller that executes sensor configuration logic or instructions, and can be implemented using a computer system such as described by FIG. 5. The LIDAR configuration system 135 may also be implemented using a combination of multiple computer systems as described in connection with FIG. 5.

In one implementation, the computer system 500 includes processing resources 510, a main memory 520, a read-only memory (ROM) 530, a storage device 540, and a communication interface 550. The computer system 500 includes at

least one processor 510 for processing information stored in the main memory 520, such as provided by a random access memory (RAM) or other dynamic storage device, for storing information and instructions which are executable by the processor 510. The main memory 520 also may be used for storing temporary variables or other intermediate information during execution of instructions to be executed by the processor 510. The computer system 500 may also include the ROM 530 or other static storage device for storing static information and instructions for the processor 510. A storage device 540, such as a magnetic disk or optical disk, is provided for storing information and instructions.

The communication interface 550 enables the computer system 500 to communicate with one or more AV subsystems 580 over a network link (e.g., a wireless or wired link). In accordance with examples, the computer system 500 receives feedback data 582 from the AV subsystems 580. The executable instructions stored in the memory 530 can include configuration instructions 522, which the processor 510 executes to determine a set of configurations to configure the adjustable parameters of the AV's LIDAR sensor system 210 based on the feedback data 582.

The processor 510 is configured with software and/or other logic to perform one or more processes, steps and other functions described with implementations, such as described by FIGS. 1 through 4, and elsewhere in the present application.

Examples described herein are related to the use of the computer system 500 for implementing the techniques described herein. According to one example, those techniques are performed by the computer system 500 in response to the processor 510 executing one or more sequences of one or more instructions contained in the main memory 520. Such instructions may be read into the main memory 520 from another machine-readable medium, such as the storage device 540. Execution of the sequences of instructions contained in the main memory 520 causes the processor 510 to perform the process steps described herein. In alternative implementations, hard-wired circuitry may be used in place of or in combination with software instructions to implement examples described herein. Thus, the examples described are not limited to any specific combination of hardware circuitry and software.

It is contemplated for examples described herein to extend to individual elements and concepts described herein, independently of other concepts, ideas or system, as well as for examples to include combinations of elements recited anywhere in this application. Although examples are described in detail herein with reference to the accompanying drawings, it is to be understood that the concepts are not limited to those precise examples. As such, many modifications and variations will be apparent to practitioners skilled in this art. Accordingly, it is intended that the scope of the concepts be defined by the following claims and their equivalents. Furthermore, it is contemplated that a particular feature described either individually or as part of an example can be combined with other individually described features, or parts of other examples, even if the other features and examples make no mention of the particular feature. Thus, the absence of describing combinations should not preclude claiming rights to such combinations.

What is claimed is:

1. A LIDAR sensor for an autonomous vehicle (AV), comprising:
 - a set of mirrors;
 - a set of lasers outputting laser beams via the set of mirrors; and

11

one or more mirror actuators to adjust the set of mirrors, in response to AV feedback from the AV, to reconfigure a beam pattern of the outputted lasers;

wherein the AV feedback indicates a speed of the AV, wherein the one or more mirror actuators reconfigure the beam pattern by modifying a vertical angular spacing of the outputted laser beams, and wherein the one or more mirror actuators dynamically increase the vertical angular spacing as the AV decreases speed, and dynamically decrease the vertical angular spacing as the AV increases speed.

2. The LIDAR sensor of claim 1, further comprising: a rotational motor that adjusts a rotational rate of the set of mirrors in response to the AV feedback.

3. The LIDAR sensor of claim 2, wherein the AV feedback indicates a speed of the AV, and wherein the rotational motor adjusts the rotational rate based on the speed of the AV.

4. The LIDAR sensor of claim 1, wherein the AV feedback indicates a road gradient.

5. The LIDAR sensor of claim 4, wherein the one or more mirror actuators adjust a general vertical angle of the beam pattern based on the road gradient.

6. The LIDAR sensor of claim 1, wherein the set of lasers adjust a pulse rate of the outputted laser beams based on the AV feedback.

7. The LIDAR sensor of claim 6, wherein the AV feedback indicates pedestrian activity in a surrounding environment of the AV, and wherein the set of lasers adjust the pulse rate of the LIDAR sensor based on the pedestrian activity.

8. An autonomous vehicle (AV) comprising: acceleration, braking, and steering systems;

a LIDAR sensor generating sensor data indicating a surrounding environment of the AV, the LIDAR sensor comprising:

a set of mirrors;

a set of lasers outputting laser beams via the set of mirrors; and

one or more mirror actuators to adjust the set of mirrors, in response to AV feedback, to reconfigure a beam pattern of the outputted lasers; and

a control system to (i) process the sensor data generated by the LIDAR sensor to autonomously operate the acceleration, braking, and steering systems of the AV;

wherein the AV feedback indicates a speed of the AV, wherein the one or more mirror actuators reconfigure the beam pattern by modifying a vertical angular spacing of the outputted laser beams, and wherein the one or more mirror actuators dynamically increase the

12

vertical angular spacing as the AV decreases speed, and dynamically decrease the vertical angular spacing as the AV increases speed.

9. The AV of claim 8, wherein the LIDAR sensor further comprises:

a rotational motor that adjusts a rotational rate of the set of mirrors in response to the AV feedback.

10. The AV of claim 9, wherein the AV feedback indicates a speed of the AV, and wherein the rotational motor adjusts the rotational rate based on the speed of the AV.

11. The AV of claim 8, wherein the AV feedback indicates a road gradient.

12. The AV of claim 11, wherein the one or more mirror actuators adjust a general vertical angle of the beam pattern based on the road gradient.

13. The AV of claim 8, wherein the set of lasers adjust a pulse rate of the outputted laser beams based on the AV feedback.

14. The AV of claim 13, wherein the AV feedback indicates pedestrian activity in a surrounding environment of the AV, and wherein the set of lasers adjust the pulse rate of the LIDAR sensor based on the pedestrian activity.

15. A LIDAR sensor for an autonomous vehicle (AV), comprising:

a set of mirrors;

a set of lasers outputting laser beams via the set of mirrors;

one or more mirror actuators to adjust the set of mirrors, in response to AV feedback from the AV, to reconfigure a beam pattern of the outputted lasers; and

a rotational motor that adjusts a rotational rate of the set of mirrors in response to the AV feedback;

wherein the AV feedback indicates a speed of the AV, and wherein the rotational motor adjusts the rotational rate based on the speed of the AV.

16. The LIDAR sensor of claim 15, wherein the AV feedback indicates a road gradient.

17. The LIDAR sensor of claim 16, wherein the one or more mirror actuators adjust a general vertical angle of the beam pattern based on the road gradient.

18. The LIDAR sensor of claim 15, wherein the set of lasers adjust a pulse rate of the outputted laser beams based on the AV feedback.

19. The LIDAR sensor of claim 18, wherein the AV feedback indicates pedestrian activity in a surrounding environment of the AV, and wherein the set of lasers adjust the pulse rate of the LIDAR sensor based on the pedestrian activity.

* * * * *