



US010674053B2

(12) **United States Patent**
Winden et al.

(10) **Patent No.:** **US 10,674,053 B2**
(45) **Date of Patent:** **Jun. 2, 2020**

(54) **VEHICULAR CAMERA WITH ADHESIVELY BONDED CONSTRUCTION**

(58) **Field of Classification Search**
CPC H04N 5/2254; H04N 5/2253; C09J 163/00
(Continued)

(71) Applicant: **MAGNA ELECTRONICS INC.**,
Auburn Hills, MI (US)

(56) **References Cited**

(72) Inventors: **Brian J. Winden**, Waterford, MI (US);
Robert A. Devota, Durand, MI (US);
Matthew C. Sesti, Williamston, MI (US);
Joseph A. Stemmer, Warren, MI (US);
Steven V. Byrne, Goodrich, MI (US);
John R. Garcia, Montrose, MI (US);
David F. Olson, Lapeer, MI (US)

U.S. PATENT DOCUMENTS

4,514,530 A 4/1985 Sellstrom et al.
4,712,879 A 12/1987 Lynam et al.
(Continued)

(73) Assignee: **MAGNA ELECTRONICS INC.**,
Auburn Hills, MI (US)

FOREIGN PATENT DOCUMENTS

CN 01059596 A 3/1992
CN 1743887 A 3/2006
(Continued)

(*) Notice: Subject to any disclaimer, the term of this patent is extended or adjusted under 35 U.S.C. 154(b) by 0 days.

Primary Examiner — Jeffery A Williams

(74) *Attorney, Agent, or Firm* — Honigman LLP

(21) Appl. No.: **16/571,633**

(22) Filed: **Sep. 16, 2019**

(57) **ABSTRACT**

(65) **Prior Publication Data**

US 2020/0014827 A1 Jan. 9, 2020

A vehicular camera includes a lens accommodated in a lens barrel, a lens holder that accommodates at least part of the lens holder, and a printed circuit board with an imager disposed thereat. After the lens is optically aligned with the imager, the adhesive is initially curable to an initially-cured state in an initial curing process for an initial-cure time period. The initially-cured adhesive is further curable to a further-cured state in a secondary curing process for a further-cure time period that is longer than the initial-cure time period. As further cured, the further-cured adhesive maintains optical alignment of the lens with the imager for use of the vehicular camera in a vehicle. The further-cured adhesive maintains at least 70% strength of bond after being exposed for 1000 hours to a temperature of 85 degrees Celsius and a humidity of 85% RH.

Related U.S. Application Data

(63) Continuation of application No. 16/384,034, filed on Apr. 15, 2019, now Pat. No. 10,419,652, which is a
(Continued)

(51) **Int. Cl.**
H04N 5/00 (2011.01)
H04N 5/225 (2006.01)
(Continued)

(52) **U.S. Cl.**
CPC **H04N 5/2254** (2013.01); **C09J 5/00** (2013.01); **C09J 163/00** (2013.01);
(Continued)

76 Claims, 8 Drawing Sheets

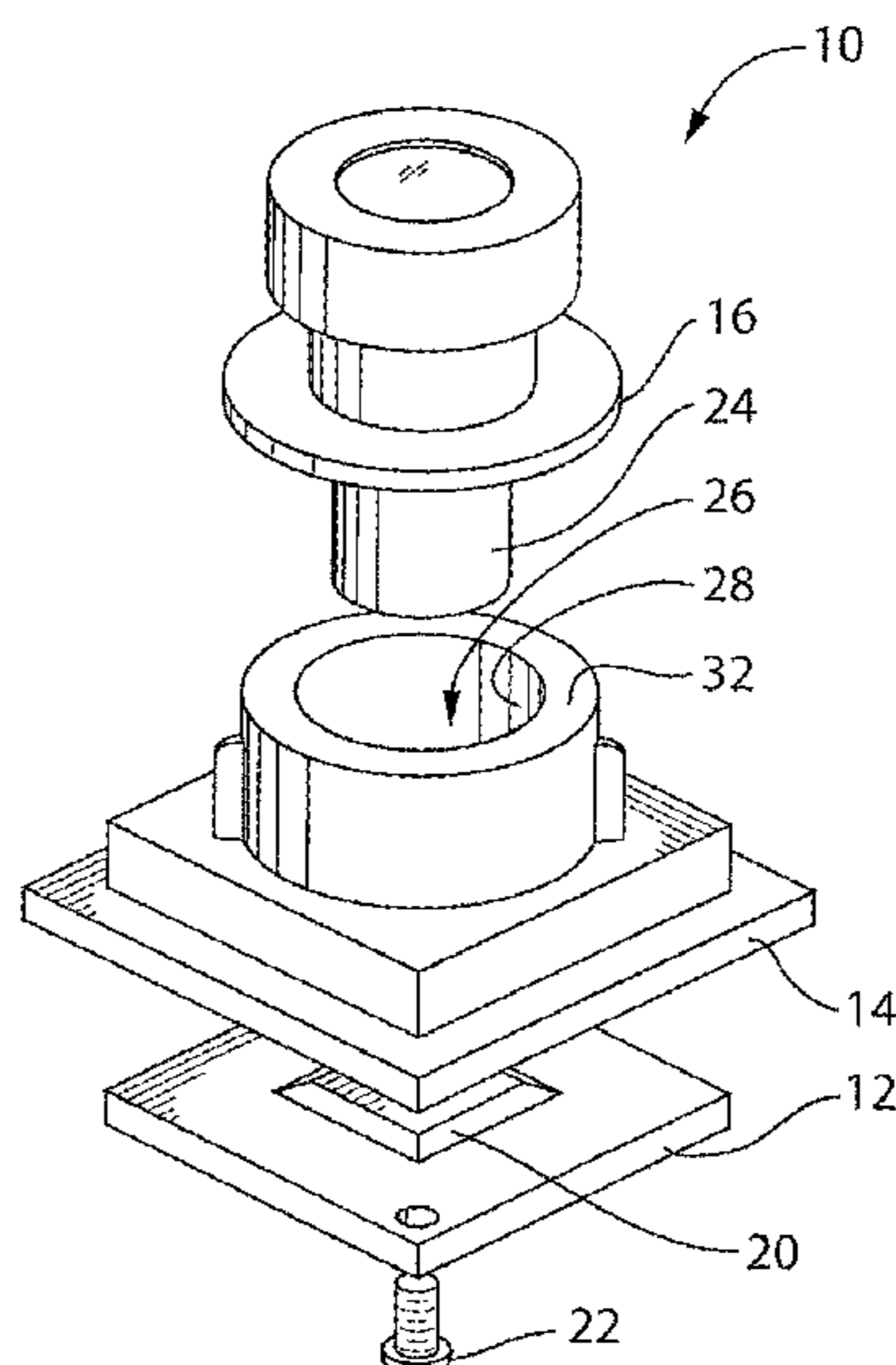

Related U.S. Application Data

continuation of application No. 15/878,749, filed on Jan. 24, 2018, now Pat. No. 10,264,168, which is a continuation of application No. 15/494,648, filed on Apr. 24, 2017, now Pat. No. 9,883,088, which is a continuation of application No. 15/349,012, filed on Nov. 11, 2016, now Pat. No. 9,635,230, which is a continuation of application No. 15/268,940, filed on Sep. 19, 2016, now Pat. No. 9,497,368, which is a continuation of application No. 14/535,739, filed on Nov. 7, 2014, now Pat. No. 9,451,138.

(60) Provisional application No. 61/905,462, filed on Nov. 18, 2013, provisional application No. 61/901,127, filed on Nov. 7, 2013.

(51) **Int. Cl.**
C09J 163/00 (2006.01)
C09J 5/00 (2006.01)

(52) **U.S. Cl.**
 CPC *H04N 5/2252* (2013.01); *H04N 5/2253* (2013.01); *C09J 2463/00* (2013.01)

(58) **Field of Classification Search**
 USPC 348/148
 See application file for complete search history.

(56) **References Cited**

U.S. PATENT DOCUMENTS

4,786,966 A 11/1988 Hanson et al.
 5,073,012 A 12/1991 Lynam
 5,076,673 A 12/1991 Lynam et al.
 5,115,346 A 5/1992 Lynam
 5,140,455 A 8/1992 Varaprasad et al.
 5,142,407 A 8/1992 Varaprasad et al.
 5,151,816 A 9/1992 Varaprasad et al.
 5,253,109 A 10/1993 O'Farrell et al.
 5,371,659 A 12/1994 Pastrick et al.
 5,406,414 A 4/1995 O'Farrell et al.
 5,497,306 A 3/1996 Pastrick
 5,525,264 A 6/1996 Cronin et al.
 5,550,677 A 8/1996 Schofield et al.
 5,559,556 A 9/1996 Kagebeck
 5,567,360 A 10/1996 Varaprasad et al.
 5,610,756 A 3/1997 Lynam et al.
 5,657,539 A 8/1997 Orikasa et al.
 5,668,663 A 9/1997 Varaprasad et al.
 5,669,699 A 9/1997 Pastrick et al.
 5,670,935 A 9/1997 Schofield et al.
 5,724,187 A 3/1998 Varaprasad et al.
 5,760,962 A 6/1998 Schofield et al.
 5,796,094 A 8/1998 Schofield et al.
 5,821,532 A 10/1998 Beaman et al.
 5,823,654 A 10/1998 Pastrick et al.
 5,854,708 A 12/1998 Komatsu et al.
 5,872,332 A 2/1999 Verma
 5,877,897 A 3/1999 Schofield et al.
 5,910,854 A 6/1999 Varaprasad et al.
 5,949,331 A 9/1999 Schofield et al.
 5,978,017 A 11/1999 Tino
 6,002,544 A 12/1999 Yatsu
 6,013,372 A 1/2000 Hayakawa et al.
 6,071,606 A 6/2000 Yamazaki et al.
 6,072,814 A 6/2000 Ryan et al.
 6,097,023 A 8/2000 Schofield et al.
 6,117,193 A 9/2000 Glenn
 6,151,065 A 11/2000 Steed
 6,154,306 A 11/2000 Varaprasad et al.
 6,176,602 B1 1/2001 Pastrick et al.
 6,178,034 B1 1/2001 Allemand et al.
 6,193,378 B1 2/2001 Tonar et al.
 6,201,642 B1 3/2001 Bos

6,222,447 B1 4/2001 Schofield et al.
 6,259,475 B1 7/2001 Ramachandran et al.
 6,276,821 B1 8/2001 Pastrick et al.
 6,292,311 B1 9/2001 Bohn et al.
 6,302,545 B1 10/2001 Schofield et al.
 6,320,176 B1 11/2001 Schofield et al.
 6,353,392 B1 3/2002 Schofield et al.
 6,396,397 B1 5/2002 Bos et al.
 6,454,449 B2 9/2002 Nestell et al.
 6,481,003 B1 11/2002 Maeda
 6,483,101 B1 11/2002 Webster
 6,498,620 B2 12/2002 Schofield et al.
 6,523,964 B2 2/2003 Schofield et al.
 6,535,242 B1 3/2003 Strumolo et al.
 6,559,435 B2 5/2003 Schofield et al.
 6,559,439 B1 5/2003 Tsuchida et al.
 6,590,658 B2 7/2003 Case et al.
 6,603,612 B2 8/2003 Nakano
 6,611,202 B2 8/2003 Schofield et al.
 6,651,187 B2 11/2003 Lacey, III
 6,654,187 B2 11/2003 Ning
 6,690,268 B2 2/2004 Schofield et al.
 6,717,610 B1 4/2004 Bos et al.
 6,757,109 B2 6/2004 Bos
 6,805,767 B2 10/2004 Shinomiya
 6,806,452 B2 10/2004 Bos et al.
 6,822,563 B2 11/2004 Bos et al.
 6,831,261 B2 12/2004 Schofield et al.
 6,891,563 B2 5/2005 Schofield et al.
 6,897,432 B2 5/2005 Schmidtke et al.
 6,946,978 B2 9/2005 Schofield
 6,977,619 B2 12/2005 March et al.
 7,004,606 B2 2/2006 Schofield
 7,005,974 B2 2/2006 McMahan et al.
 7,015,944 B2 3/2006 Holz et al.
 7,031,075 B2 4/2006 Tsuji
 7,038,577 B2 5/2006 Pawlicki et al.
 7,095,123 B2 8/2006 Prior
 7,095,572 B2 8/2006 Lee et al.
 7,123,168 B2 10/2006 Schofield
 7,215,479 B1 5/2007 Bakin
 7,255,451 B2 8/2007 McCabe et al.
 7,268,957 B2 9/2007 Frenzel et al.
 7,339,149 B1 3/2008 Schofield et al.
 7,370,983 B2 5/2008 DeWind et al.
 7,391,458 B2 6/2008 Sakamoto
 7,419,315 B2 9/2008 Grata et al.
 7,423,665 B2 9/2008 Ray et al.
 7,453,509 B2 11/2008 Losehand et al.
 7,599,134 B2 10/2009 Bechtel et al.
 7,768,574 B2 8/2010 Humpston
 7,965,336 B2 6/2011 Bingle et al.
 8,064,146 B2 11/2011 Iwasaki
 8,120,652 B2 2/2012 Bechtel et al.
 8,318,512 B2 11/2012 Shah et al.
 8,542,451 B2 9/2013 Lu et al.
 9,277,104 B2 3/2016 Sesti et al.
 9,338,334 B2 5/2016 Lu et al.
 9,451,138 B2 9/2016 Winden et al.
 9,497,368 B1 11/2016 Winden et al.
 9,635,230 B2 4/2017 Winden et al.
 9,883,088 B2 1/2018 Winden et al.
 10,264,168 B2 4/2019 Winden et al.
 10,419,652 B2 9/2019 Winden et al.
 2002/0159270 A1 10/2002 Lynam et al.
 2003/0090569 A1 5/2003 Poechmueller
 2003/0137595 A1 7/2003 Takachi
 2004/0016870 A1 1/2004 Pawlicki et al.
 2004/0032321 A1 2/2004 McMahan et al.
 2004/0051634 A1 3/2004 Schofield et al.
 2005/0104995 A1 5/2005 Spryshak et al.
 2005/0190283 A1 9/2005 Ish-Shalom et al.
 2005/0232469 A1 10/2005 Schofield et al.
 2005/0274883 A1 12/2005 Nagano
 2006/0038668 A1 2/2006 DeWard et al.
 2006/0049533 A1 3/2006 Kamoshita
 2006/0050018 A1 3/2006 Hutzet et al.
 2006/0054802 A1 3/2006 Johnston
 2006/0056077 A1 3/2006 Johnston

(56)

References Cited

U.S. PATENT DOCUMENTS

2006/0061008 A1 3/2006 Kamer et al.
2006/0065436 A1 3/2006 Gaily et al.
2006/0077575 A1 4/2006 Nakai et al.
2006/0125919 A1 6/2006 Camilleri et al.
2006/0171704 A1 8/2006 Bingle et al.
2006/0184297 A1 8/2006 Higgins-Luthman
2007/0096020 A1 5/2007 Mitsugi et al.
2007/0279518 A1 12/2007 Apel et al.
2008/0024833 A1 1/2008 Kawasaki
2008/0024883 A1 1/2008 Iwasaki
2008/0043105 A1 2/2008 Kallhammer et al.
2009/0010494 A1 1/2009 Bechtel et al.
2009/0244361 A1 10/2009 Gebauer et al.
2010/0103308 A1 4/2010 Butterfield et al.
2010/0279439 A1 11/2010 Shah et al.
2011/0298968 A1 12/2011 Tseng et al.

2013/0242099 A1* 9/2013 Sauer H04N 5/2257
348/148
2014/0000804 A1 1/2014 Looi et al.
2014/0022657 A1 1/2014 Lu et al.

FOREIGN PATENT DOCUMENTS

EP 1271214 A1 1/2003
EP 1351316 A2 10/2003
EP 1605520 A1 12/2005
JP 08084277 3/1996
JP 2006-293100 A 10/2006
JP 2006-350372 A 12/2006
WO 2001/044850 A2 6/2001
WO 2004/010679 A2 1/2004
WO 2006/029995 A1 3/2006
WO 2006/029996 A1 3/2006
WO 2007/053404 A2 5/2007
WO 2010111465 A1 9/2010

* cited by examiner

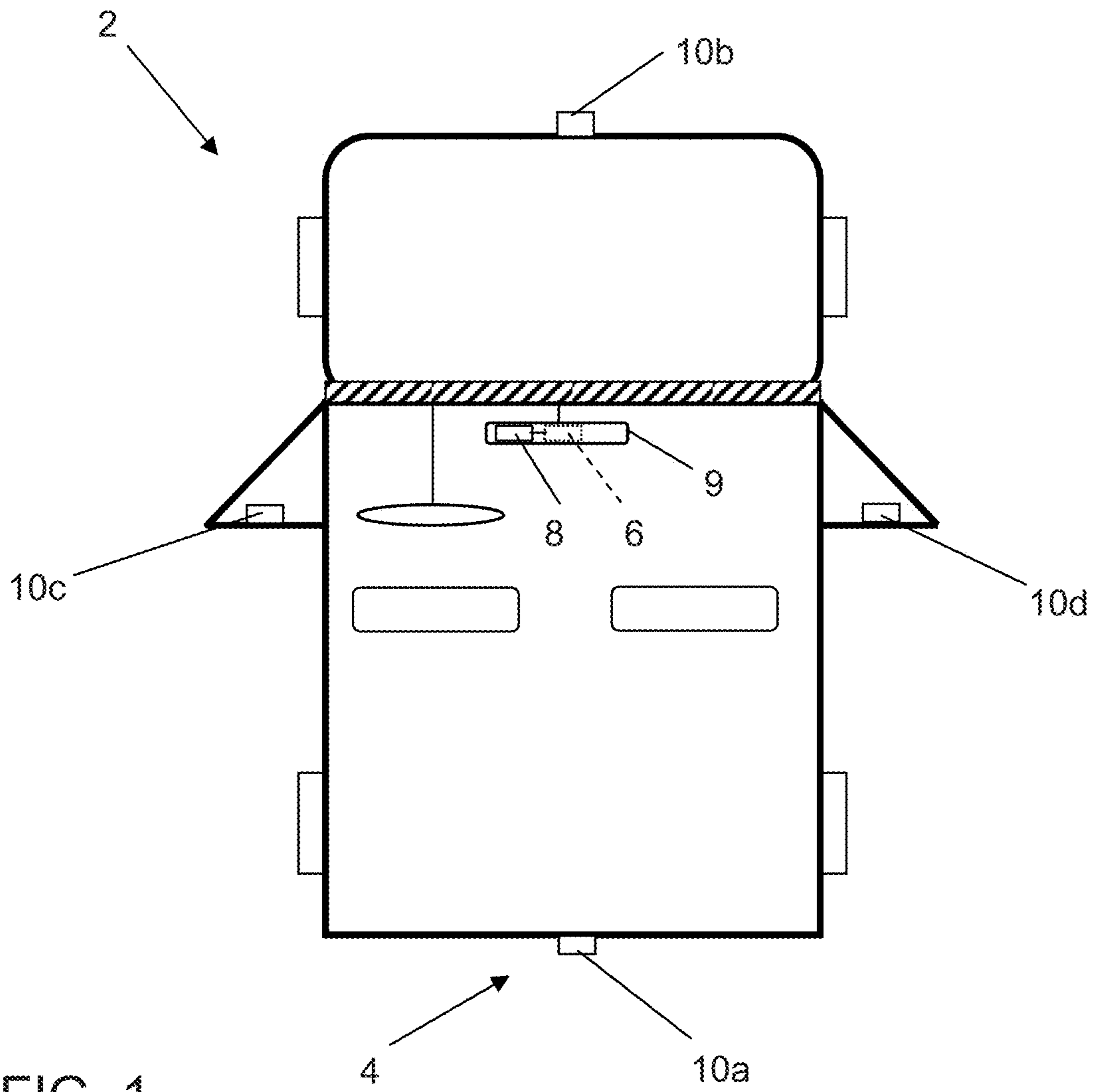

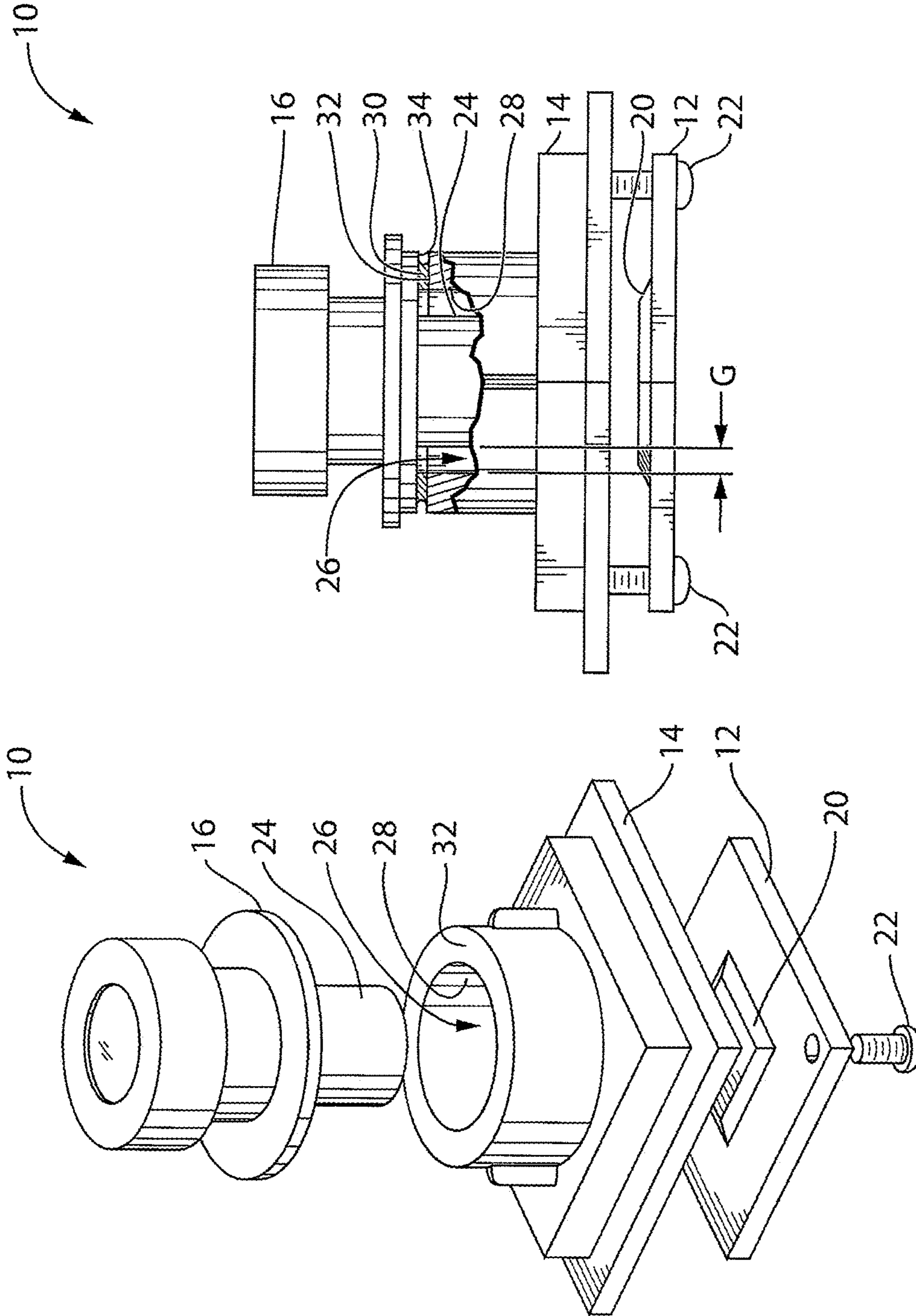
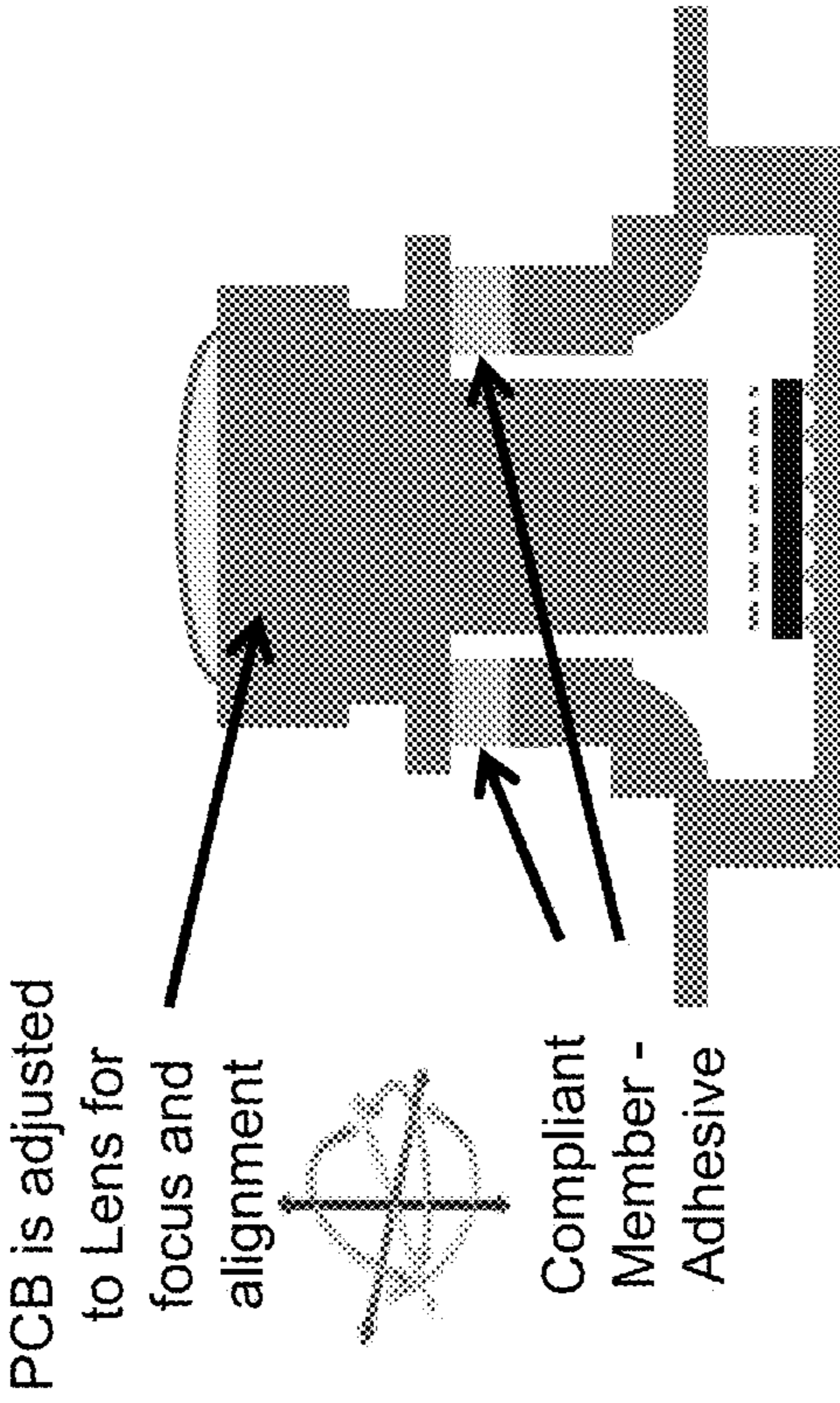

FIG. 3

FIG. 2



Camera Type 2

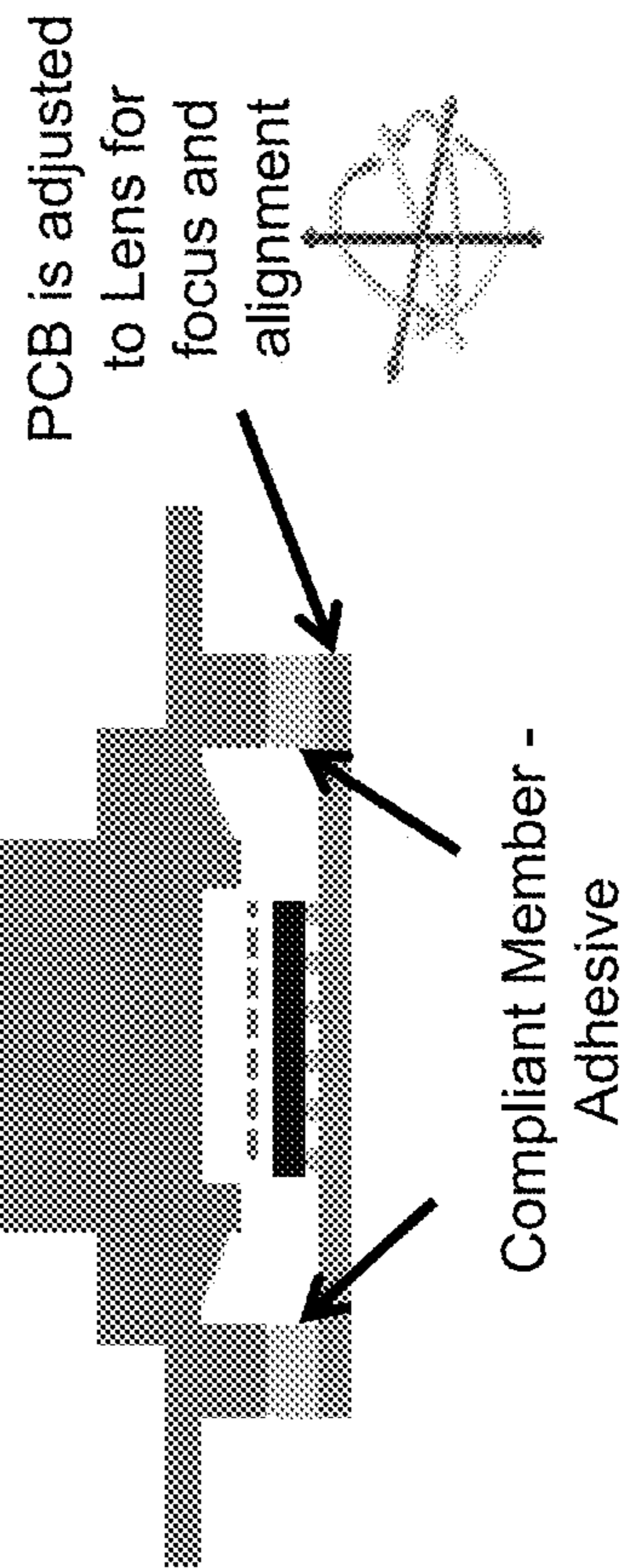

FIG. 5

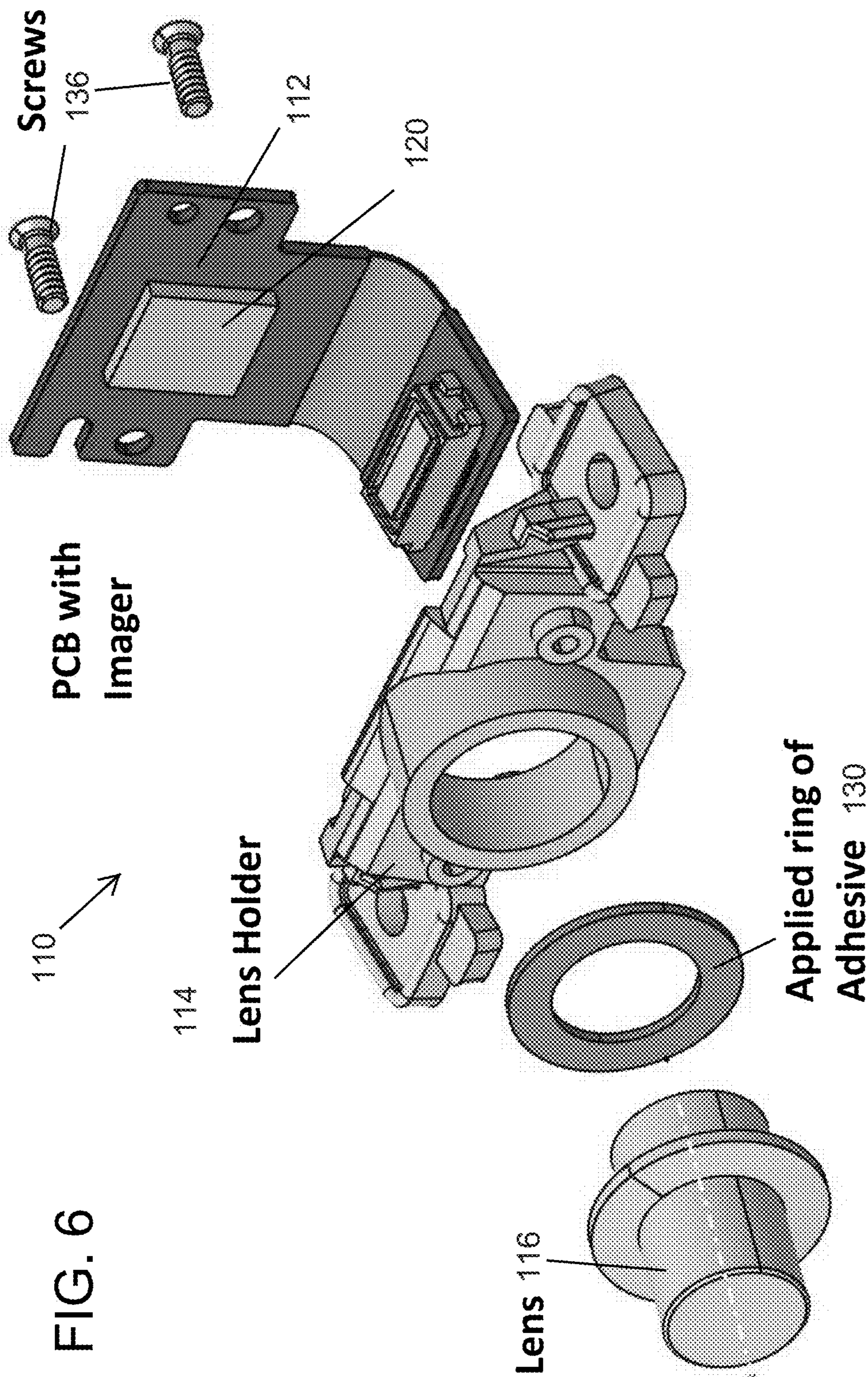

FIG. 6

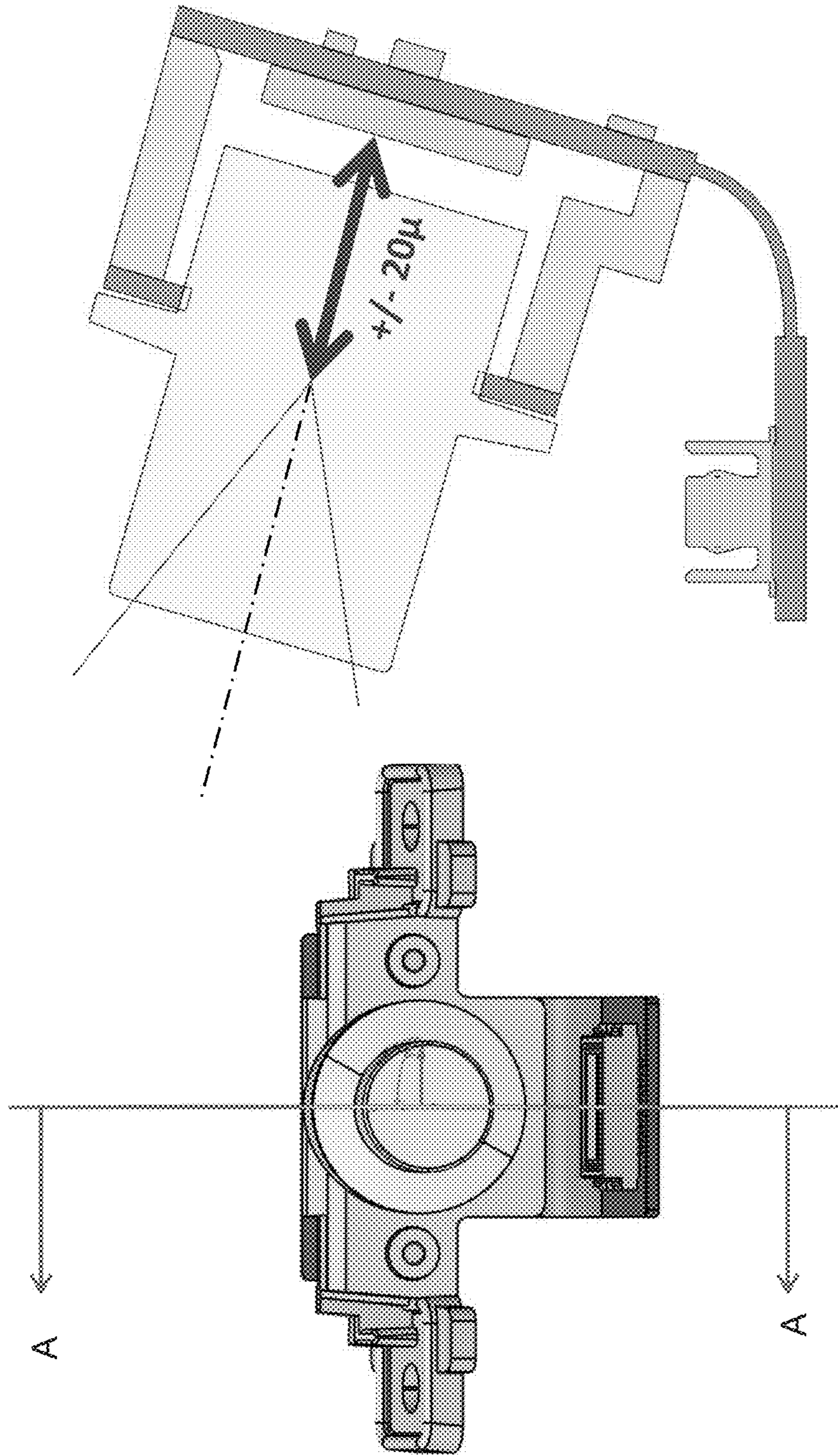

FIG. 7

FIG. 7A

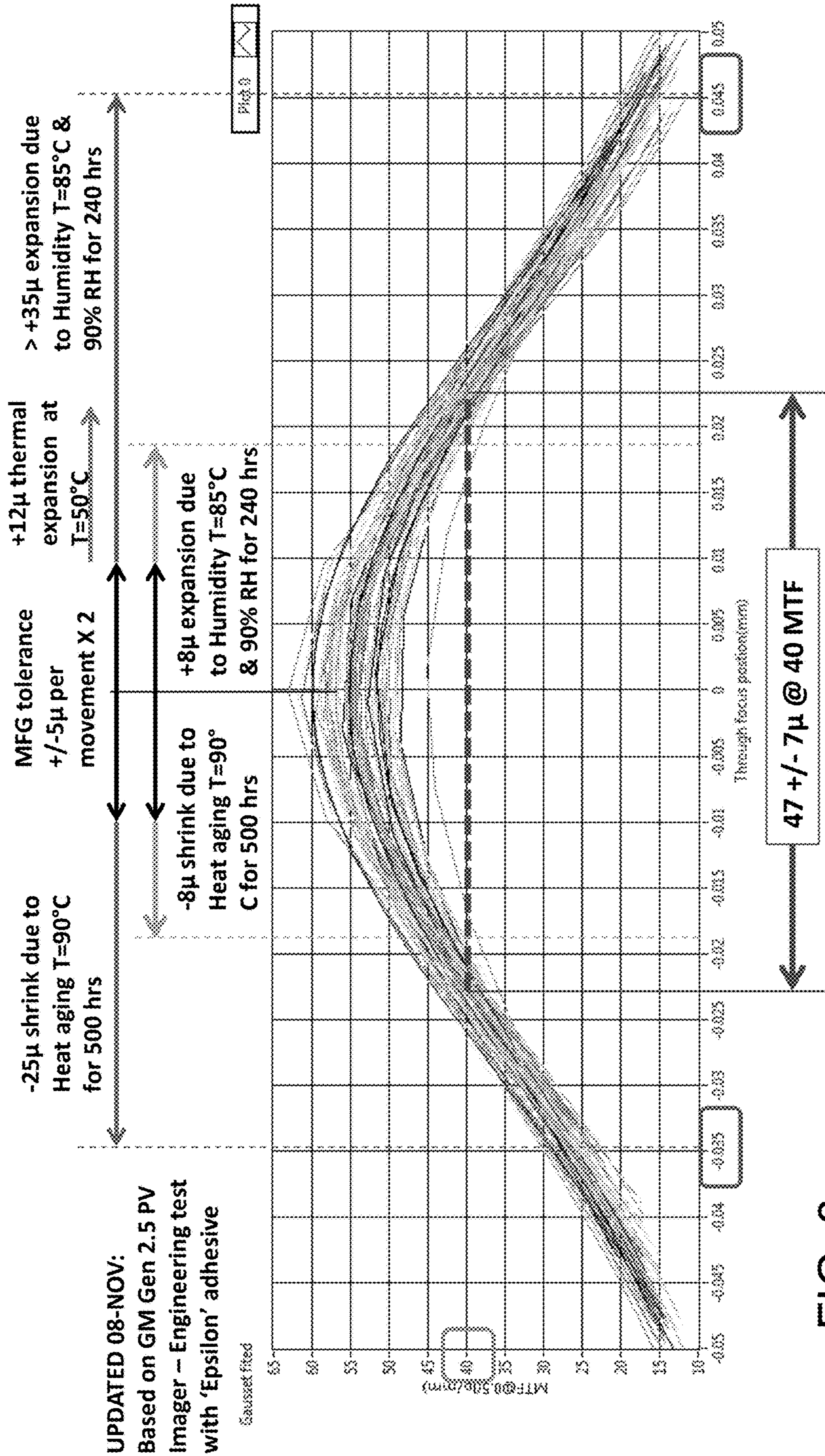

FIG. 8

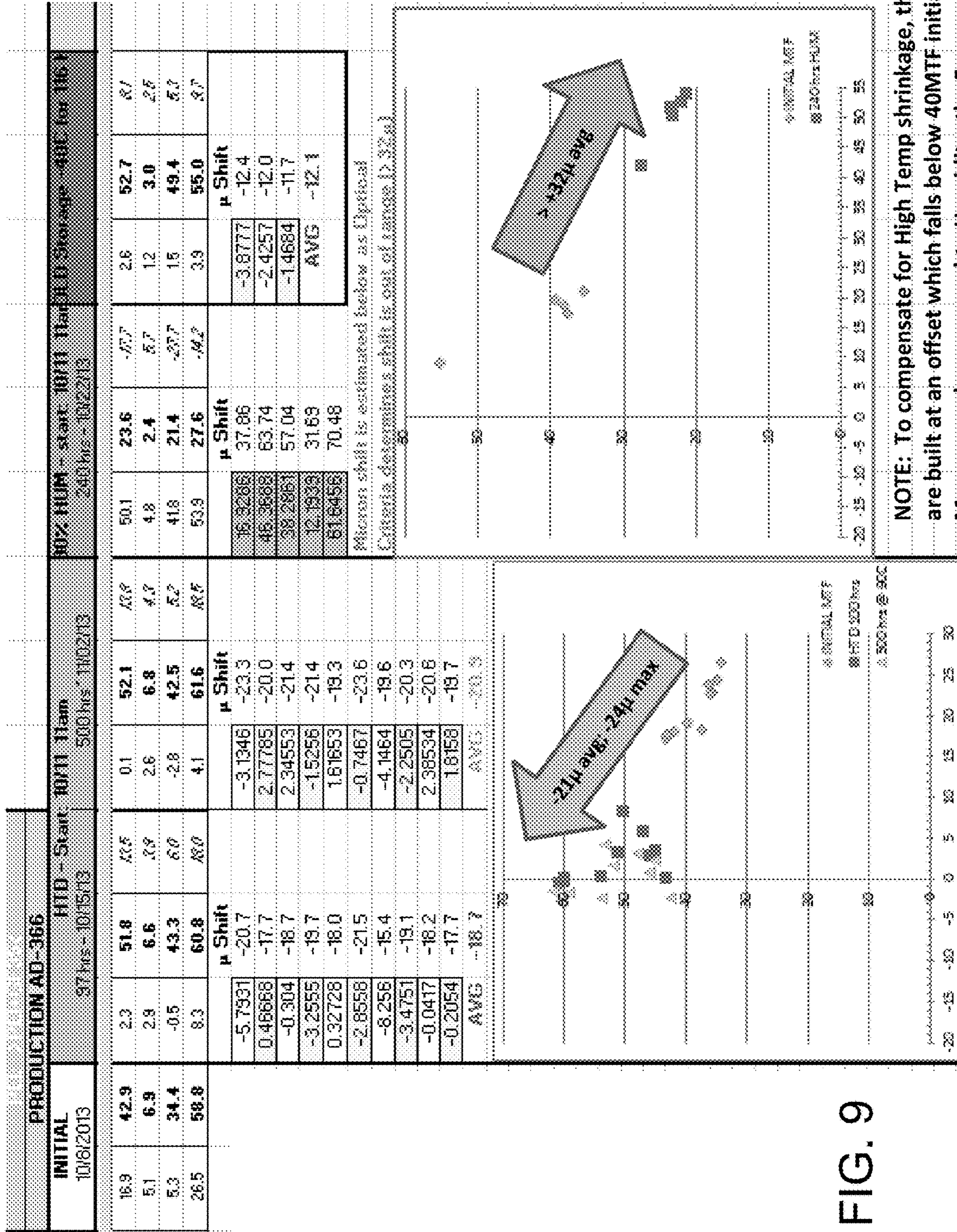

FIG. 9

NOTE: To compensate for High Temp shrinkage, the imagers are built at an offset which falls below 40MTF initial score. Moreover when exposed to Humidity, the Focus expands and falls further below 40MTF.

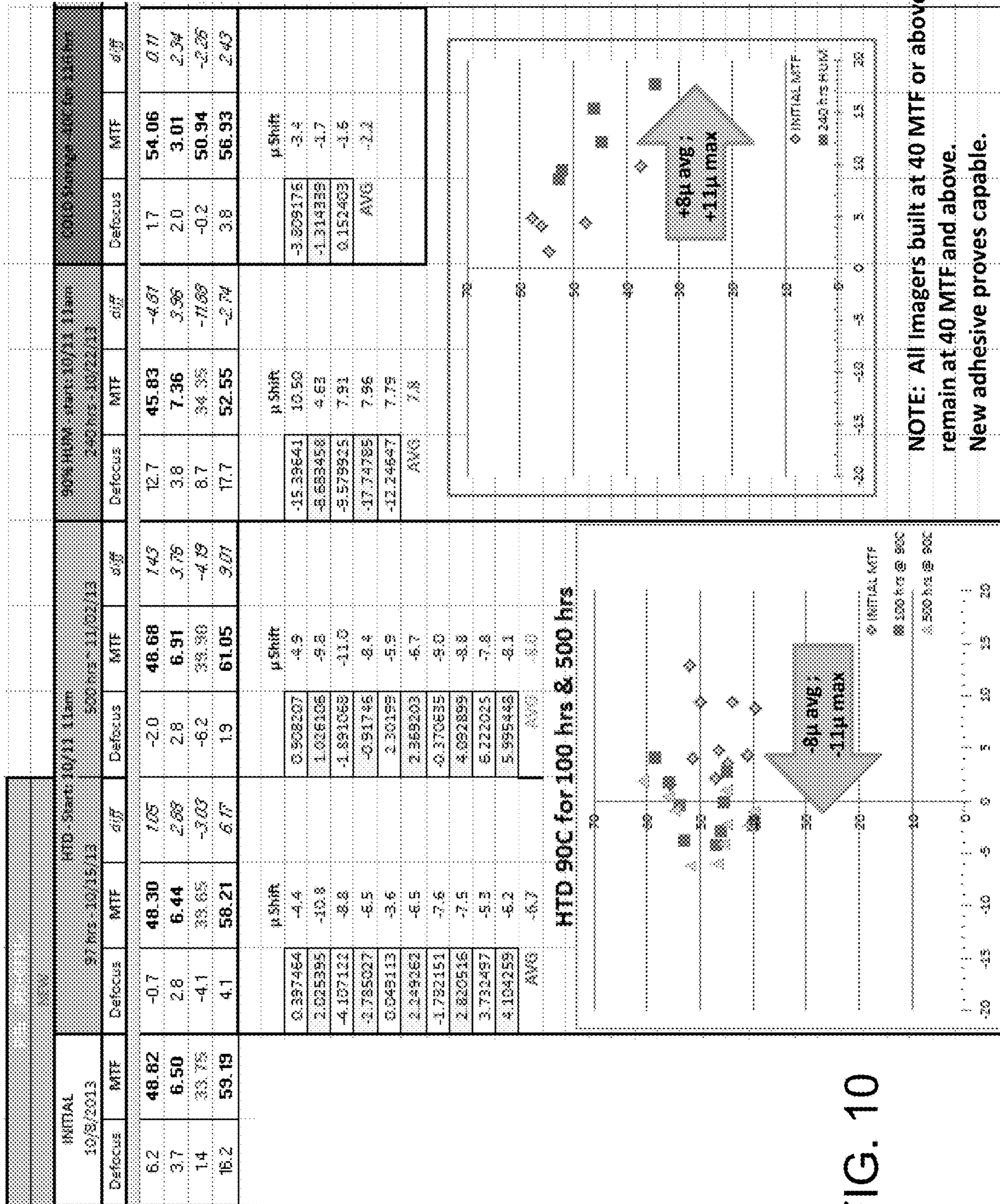

FIG. 10

VEHICULAR CAMERA WITH ADHESIVELY BONDED CONSTRUCTION

CROSS REFERENCE TO RELATED APPLICATIONS

The present application is a continuation of U.S. patent application Ser. No. 16/384,034, filed Apr. 15, 2019, now U.S. Pat. No. 10,419,652, which is a continuation of U.S. patent application Ser. No. 15/878,749, filed Jan. 24, 2018, now U.S. Pat. No. 10,264,168, which is a continuation of U.S. patent application Ser. No. 15/494,648, filed Apr. 24, 2017, now U.S. Pat. No. 9,883,088, which is a continuation of U.S. patent application Ser. No. 15/349,012, filed Nov. 11, 2016, now U.S. Pat. No. 9,635,230, which is a continuation of U.S. patent application Ser. No. 15/268,940, filed Sep. 19, 2016, now U.S. Pat. No. 9,497,368, which is a continuation of U.S. patent application Ser. No. 14/535,739, filed Nov. 7, 2014, now U.S. Pat. No. 9,451,138, which claims the filing benefits of U.S. provisional application Ser. No. 61/905,462, filed Nov. 18, 2013 and Ser. No. 61/901,127, filed Nov. 7, 2013, which are hereby incorporated herein by reference in their entireties.

FIELD OF THE INVENTION

The present invention relates generally to vehicle vision systems and, more particularly, to vehicular cameras for vehicle vision systems.

BACKGROUND OF THE INVENTION

Vehicular cameras are used for a variety of purposes, such as to assist a driver in avoiding obstacles behind a vehicle when backing up, and to detect imminent collisions ahead of the vehicle when driving forward. A vehicular camera includes a lens that focuses video input on an image sensor provided on an imager. In general, the position of the lens relative to the image sensor can impact the quality of the video input received by the image sensor. For example, if the lens is positioned such that the video input is not in focus, then the video information passed to the driver may be blurry, and other vehicular systems, such as a collision detection system for example, may not function as well as they otherwise could. As the size of the camera is reduced, the positioning of the lens relative to the image sensor may be relatively more critical, at least because small variations in position can result in relatively large changes in angular offset. Therefore, the positioning of the lens relative to the image sensor may be particularly critical for vehicular rearview cameras. Furthermore, it is important that the camera be capable of holding the lens in position over a selected period of time under certain operating conditions, so that the performance of the camera is maintained over a useful operating life.

Several aspects of the camera may contribute to the overall tolerance in the position of the lens relative to the image sensor. For example, for lenses and lens holders that are threaded, the threaded connection therebetween has a tolerance associated with it. The angle of cast of the lens holder has a tolerance associated with it. The position of the imager has a tolerance associated with it.

It is desirable to provide a more integrated, lower cost camera assembly with means for positioning the lens relative to the imager within tolerance.

SUMMARY OF THE INVENTION

The present invention provides a vehicular camera assembly having a lens and imager, and with the lens focused at

the imager and adhered relative to the imager using an adhesive that provides enhanced bond strength and stability, and that is resistant to environmental aging. The adhesive is initially curable in an initial curing process that comprises exposure to UV light, and the initially-cured adhesive is further curable to a further cured strength in a secondary curing process.

The adhesive comprises a UV curable and heat curable one-part filled adhesive having a viscosity at 23 degrees C. from about 5,000 mPa to about 150,000 mPa and comprising an epoxy resin. The preferred adhesive is adhesive OB749 or AD VE 112203 or OB787, manufactured by Delo Industrial Adhesives of Sudbury, M A and Windach, Germany. Such adhesives are UV-/light-/heat curing adhesives having medium viscosity.

These and other objects, advantages, purposes and features of the present invention will become apparent upon review of the following specification in conjunction with the drawings.

BRIEF DESCRIPTION OF THE DRAWINGS

FIG. 1 is a plan view of a vehicle with a vision system that incorporates cameras in accordance with the present invention;

FIG. 2 is an exploded perspective view of a vehicular camera in accordance with an first embodiment of the invention wherein a lens barrel is adhesively secured to a lens holder via a UV-curable adhesive;

FIG. 3 is a cutaway side view of the vehicular camera shown in FIG. 2, in an assembled state;

FIG. 4 is a camera of the present invention, which is assembled by the lens assembly being held in a fixed position while the imager printed circuit board or PCB (with the image sensor) is positioned relative to the lens assembly;

FIG. 5 is a camera of the present invention, which is assembled by the imager PCB being held in a fixed position while the lens is positioned relative to the PCB;

FIG. 6 is an exploded view of a camera assembly that is assembled with an adhesive in accordance with the present invention;

FIG. 7 is an end view of the camera assembly of FIG. 6;

FIG. 7A is a sectional view of the camera assembly taken along the line A-A in FIG. 7;

FIG. 8 is a graph showing the movement of the lens relative to the imager after testing for various camera assemblies;

FIG. 9 shows test results of an exemplary production adhesive; and

FIG. 10 shows test results of the preferred adhesive for the camera assembly of the present invention.

DETAILED DESCRIPTION OF THE INVENTION

A vehicle vision system and/or driver assist system and/or object detection system and/or alert system operates to capture images exterior of the vehicle and may process the captured image data to display images and to detect objects at or near the vehicle and in the predicted path of the vehicle, such as to assist a driver of the vehicle in maneuvering the vehicle in a rearward direction. The vision system includes an image processor or image processing system that is operable to receive image data from one or more cameras and provide an output to a display device for displaying images representative of the captured image data. Optionally, the vision system may provide a top down or bird's eye

or surround view display and may provide a displayed image that is representative of the subject vehicle, and optionally with the displayed image being customized to at least partially correspond to the actual subject vehicle.

Referring now to the drawings and the illustrative embodiments depicted therein, a vehicle **2** includes an imaging system or vision system **4** that includes at least one exterior facing imaging sensor or camera **10**, such as a rearward facing imaging sensor or camera **10a** (and the system may optionally include multiple exterior facing imaging sensors or cameras, such as a forwardly facing camera **10b** at the front (or at the windshield) of the vehicle, and a sidewardly/rearwardly facing camera **10c**, **10d** at respective sides of the vehicle), which captures images exterior of the vehicle, with the camera having a lens for focusing images at or onto an imaging array or imaging plane or imager of the camera (FIG. 1). The vision system **4** includes a control or electronic control unit (ECU) or processor **6** that is operable to process image data captured by the cameras and may provide displayed images at a display device **8** for viewing by the driver of the vehicle (although shown in FIG. 1 as being part of or incorporated in or at an interior rearview mirror assembly **9** of the vehicle, the control and/or the display device may be disposed elsewhere at or in the vehicle). The data transfer or signal communication from the camera to the ECU may comprise any suitable data or communication link, such as a vehicle network bus or the like of the equipped vehicle.

FIG. 2 shows an exploded view of an exemplary vehicular camera construction **10**, which may be assembled in accordance with the present invention. The vehicular camera **10** includes an imager **20**, a lens holder such as a front camera housing **14** and a lens **16**. The vehicular camera **10** may include other components such as additional circuitry for processing the video input received by the imager **20**, such as, for example, circuitry for providing graphic overlay to the video input or the like. The vehicular camera **10** may further be configured to transmit the video input to other vehicular devices, such as a display controller (not shown) for a cabin-mounted display (not shown).

The imager **20** may be a charge-coupled device (CCD) or a complimentary metal-oxide semiconductor (CMOS) sensor. Referring additionally to FIG. 3, the imager **20** is mounted to a printed circuit board (PCB) **12**. The imager **20** is positioned to receive optical images from the lens **16**. Optionally, and such as shown in FIGS. 2 and 3, the imager **20** may be connected to the lens holder **14** by a plurality of threaded fasteners **22**.

The lens **16** is mounted to the lens holder/front camera housing **14** at a selected position for focusing images onto the sensing surface of the imager **20**. The lens **16** may comprise any suitable type of lens known in the art and may comprise multiple glass or plastic lens optics or elements disposed in and along a lens barrel. In the illustrated embodiment, the lens **16** has an exterior surface **24** that is configured to be received in a cylindrical aperture **26** having an aperture wall **28** on the lens holder/front camera housing **14**. The exterior surface **24** and the aperture wall **28** may have a selected amount of clearance therebetween, shown by a gap **G**. An adhesive **30** is provided for holding the lens **16** in a specific position relative to the lens holder/front camera housing **14**. More particularly, the adhesive **30** may be applied between a first axial face **32** on the lens holder/front camera housing **14**, and a second axial face **34** on the lens **16**.

The position of the lens **16** relative to the imager **20** impacts the degree of focus present in the optical images

received by the imager **20** and thus the performance of the camera **10** and the optical alignment of the optical image on the imager.

To control the position of the lens **16**, a positioning system may be provided that includes a robot. The robot holds and adjusts the position of the lens **16** relative to the lens holder/front camera housing **14** until a target object appears in suitable focus and at a suitable position on the imager **20**, prior to the curing or hardening of the adhesive **30**. The adjustment of the lens **16** relative to the lens holder/front camera housing **14** is facilitated by providing the selected amount of clearance between the exterior surface **24** of the lens **16** and the aperture wall **28** of the lens holder/front camera housing **14**. Additionally, the thickness of the layer of adhesive **30** between the lens **16** and lens holder/front camera housing **14** may be selected to provide a suitable amount of relative angular adjustment between the lens **16** and lens holder **14**/front camera housing. The thickness of the layer of adhesive may be approximately 0.75 mm prior to adjustment of the lens **16**.

Once the lens **16** has been suitably positioned by the robot, the adhesive **30** is initially cured by exposure to UV light while the robot holds the lens **16** in position. The UV light may be provided from a plurality of UV sources about the periphery of the camera **10**. The initial curing of the adhesive **30** may result in the adhesive being strong enough to hold the lens **16** in the lens holder/front camera housing **14** without needing the robot to grip the lens **16**, and may take less than about 10 seconds, such as less than about 7 seconds. However, the lens **16** may be susceptible to movement if it incurs a relatively small disturbance at this stage. After the initial curing, the camera **10** may be placed by the robot relatively gently on a conveyor and moved to a further curing station, such as a further UV curing station for a further UV curing period, such as, for example, about 25 seconds. Another curing station, such as another UV curing station may optionally be provided to further cure the adhesive **30** for another period, such as about 25 seconds, after the camera **10** leaves the first UV curing station. Subsequent to the UV curing, the camera **10** may be transferred to another curing station where the adhesive **30** can be thermally cured, or may be cured by exposure to some other secondary curing condition, to achieve its fully cured strength so that it can hold the lens **16** in position during use on a vehicle. The step of initially curing the adhesive **30** using UV light may be relatively instantaneous. The step of thermally curing the adhesive may take several minutes or hours. As an additional or alternative curing measure, the adhesive **30** may be moisture cured.

Providing an adhesive **30** that has an initial curability by UV light is advantageous in that the robot is not needed to hold the lens **16** in position over the period of time that it would take for the secondary curing condition to sufficiently harden the adhesive **30** to be self-supporting. Once the camera **10** is transferred from the robot to the curing fixture, the robot can be used for the positioning of another lens **16** in another lens holder **14**/front camera housing. Because the task of positioning the lens **16** and initially curing the adhesive **30** using UV light can take less time than fully thermally curing of the adhesive **30**, a single robot can feed cameras **10** with initially cured lenses to a plurality of curing fixtures, thereby providing the capability of achieving a relatively high rate of production per robot.

Once fully cured, the adhesive **30** may be capable of holding the lens **16** in position with at least a selected strength of bond between the lens **16** and lens holder/front camera housing **14** under one or more selected operating

5

conditions. For example, the adhesive **30** may be capable of holding the lens **16** in position after a selected time period of 1000 hours of exposure to a selected temperature of about 85 degrees Celsius and optionally a humidity of approximately 85%. Any of the aforementioned selected values may be selected to suit the particular environment that the camera **10** is expected to experience during use. The selected time period may, for example, be some other time period, such as approximately 1200 hours. The selected adhesive **30** may be further capable of holding the lens **16** in position after a selected time period exposed to a selected temperature of about -40 degrees Celsius.

The adhesive **30** may be applied by the robot itself prior to adjustment of the lens **16** relative to the lens holder/front camera housing **14** (where the lens is brought into focus with the imager and is optically center-aligned therewith). Alternatively, the adhesive **30** may be applied by some other device prior to (or during) possession of the camera **10** by the robot.

Optionally, and aside from fixing the position of the lens **16** relative to the lens holder/front camera housing **14**, the adhesive **30** may also hermetically seal the interior of the camera **10** against the outside environment.

Numerous adhesives were attempted for use as the adhesive **30**. For example, it was found that some adhesives, such as some UV-cure free radical acrylates that have the capability of being initially cured using UV light, have a reduced strength (such as a reduced tensile strength) under exposure to elevated operating temperatures such as about 85 degrees Celsius over a selected period of time. It was further found that adhesives, such as some UV-curable free radical epoxy hybrids also have a reduced strength (such as a reduced tensile strength) under exposure to elevated operating temperatures such as about 85 degrees Celsius over a selected period of time. Some anionic cyanoacrylates that were tried were unsuitable as they produced too much outgas for optical use. Other adhesives, such as some UV-cure free radical silicones or the like, have a relatively low dimensional stability and are thus not suitable.

It has been found that a suitable adhesive that can be used for the adhesive is adhesive AD VE 43812 manufactured by Delo Industrial Adhesives of Windach, Germany. This adhesive is a low-temperature cure, epoxy-amine adhesive that can be cured initially relatively quickly by exposure UV light. Aspects of this adhesive are suitable for use in a vehicular camera, such as described in U.S. Pat. No. 8,542,451 and/or International Publication No. WO 2013/063014, which are hereby incorporated herein by reference in their entireties.

Automotive cameras are assembled by way of a precise spatial positioning of the image sensor relative to the lens. This may be achieved in two ways. For a camera of the type shown in FIG. **4**, the lens assembly is held in a fixed position while the imager printed circuit board or PCB (with image sensor) is positioned relative to the lens assembly (such as via a robot that moves the PCB relative to the lens assembly, which is held or fixed at a fixture). For a camera of the type shown in FIG. **5**, the imager PCB is held in a fixed position (such as via a fixture) while the lens is positioned (such as via a robot) relative to the fixtured PCB (such as by utilizing aspects of the systems described in International Publication No. WO 2013/063014, which is hereby incorporated herein by reference in its entirety). The camera may have the lens threadedly attached at the lens holder and threadedly adjustable to adjust the focus of the images at the imager. Optionally, the lens barrel may threadedly attach at the lens holder, or the lens barrel may adhesively attach at the lens

6

holder, or the lens barrel may threadedly and adhesively attach at the lens holder. Optionally, the lens barrel may be unitarily formed with or integrated into the lens holder such that they comprise a single or unitary element or piece of unitary construction.

For either type of cameras, a compliant connecting member or element must exist between the two components that allows for the relative movement or adjustment of the lens relative to the imager (to bring the lens into focus with the imager and to optically center-align the lens with the imager). This connecting member or bonding material or element must also have a means of being permanently fixed once the desired position is found. A UV curable adhesive, such as described in U.S. Pat. No. 8,542,451 and/or International Publication No. WO 2013/063014, which are hereby incorporated herein by reference in their entireties, may be used for this member.

FIGS. **6**, **7** and **7A** show views of another exemplary vehicular camera construction **110**, which may be assembled in accordance with the present invention. The vehicular camera **110** includes an imager **120** disposed at a printed circuit board or PCB **112**, a lens holder **114** and a lens **116**. The vehicular camera **110** may include other components such as additional circuitry for processing the video input received by the imager **120**, such as, for example, circuitry for providing graphic overlay to the video input or the like. The vehicular camera **110** may further be configured to transmit the video input to other vehicular devices, such as a display controller (not shown) for a cabin-mounted display (not shown). As shown in FIG. **6**, the adhesive **130** may be disposed between the lens **116** and the lens holder **114**, which is attached at the printed circuit board **112** via a plurality of fasteners or screws **136**.

The front camera module (FCM) of the present invention is designed with the intent to maintain highest focus possible throughout the life and usage of the camera. The focus is found during the assembly process (such as during an assembly process of the type described in U.S. Pat. No. 8,542,451 and/or International Publication No. WO 2013/063014, which are hereby incorporated herein by reference in their entireties), and is maintained over the life of the part. This effective focal length (EFL) may have a minimum tolerance of about ± 0.02 mm (± 20 p).

In order to be suitable for use on a vehicle over the lifetime of the vehicle, the FCM must meet the ECE-R48 government regulation for automatic high-beam control (AHBA) functions. AHBA must be capable to detect an oncoming vehicle, and shutdown the high-beam/revert back to low-beam while the oncoming vehicle is greater than 400 m distance from the subject or equipped or host vehicle. The required distance has been correlated to a focus score threshold for the Camera. This focus threshold is determined by testing done by both the FCM manufacturer and the vehicle manufacturer and is 40 line pairs/mm (MTF). This focus threshold must be maintained for the life of the camera, from end-of-line build confirmation focus score to up to ten years of service in the field.

The focus requirement is shown in FIG. **8**. The graph of FIG. **8** shows typical through-focus curves for the lenses used on the forward facing camera module (FCM). The challenge is to build at a specification that provides an optimized optical zone, such as to build at about 40 MTF, and to maintain that focus over time. Note that typical capability to achieve this performance resides in a narrow distance of, for example, about 47μ . Thus, the FCM imager assembly, once built, cannot move more than, for example, about 0.040 mm or so, over its lifetime of use on a vehicle.

This includes its life and use during heat exposure, during thermal expansion during normal operation, during exposure to humidity and/or the like, and includes manufacturing tolerances and variations.

FIG. 8 shows test results for the adhesive of the present invention as compared to other exemplary proposed production intent adhesives. Based on validation to environments requirements (such as maintaining focus greater than 40 MTF after exposure to (i) high temperature degradation (400 hours at 90 degrees C.) and (ii) humidity (240 hours at 85 degrees C. and 90% relative humidity)), the graph shows that the other exemplary adhesive has a total movement of approximately -35μ to $+45\mu$, which results in about $+80\mu$ total movement, which is much greater than the minimum lens capability (such as, for example, about $+40\mu$). As shown in FIG. 8, the adhesive of the present invention has a total movement of approximately -18μ to $+18\mu$, which results in about $+36\mu$ total movement, which is less than the minimum lens capability, and thus meets the desired performance. FIGS. 9 and 10 show further test results of an exemplary production adhesive (FIG. 9) and the adhesive as applied in accordance with the present invention (FIG. 10).

Thus, the present invention provides an improved adhesive that provides enhanced performance and strength of the bond that holds the lens relative to the imager. The adhesive was selected based on many of its properties—dimensional stability, resistance to environmental conditioning, quick cure time, bond strength, dual cure nature, and the like. Requirements for improved focus for high resolution mega pixel cameras and forward facing machine vision systems have led to requests for such an enhanced adhesive. It has been found that a higher bond strength is desired to better support global manufacturing processes in which cure parameters (which effect adhesive properties and bond strength) may vary. In summary, improved dimensional stability and bond strength have been seen as desirable characteristics of the selected adhesive.

In general and as previously stated, the present invention provides an adhesive for a vehicular camera that has a high bond strength and excellent dimensional stability, and that is resistant to environmental aging and is UV curable with secondary cure mechanism. The below list is a summary of expectations:

- 40 degrees C. to 105 degrees C. operating range while maintaining greater than about 70 percent strength
- Tensile strength greater than 700 PSI
- Greater than about 50 Shore D hardness
- 30 k to 70 k cp viscosity
- UV Curable fixture in less than about 7 seconds
- Fully Curable in about 30 seconds or more
- Secondary two-part, moisture or thermal
- Non-hygroscopic (no significant moisture swell)
- Cure depth greater than about 3 mm
- Bond to PBT/PC and PBT plastics, FR4 PCB's, zinc and aluminum.
- Bond Shear Strength greater than about 1000 PSI with less than about 60 percent reduction at about 85 degrees C.
- Very little to no out gassing
- Withstand 1210 hours at about 85 degrees C./85% humidity
- Automotive grade
- Glass Transition Temperature greater than about 90 degrees C.

The below lists shows how the adhesive of the present invention has improved properties in comparison to the currently used product

- Higher Tg (95 degrees C. vs. 86 degrees C.)
- Less Thermal expansion (44-113 vs. 152-190)
- Less shrinkage (2.2% vs. 3.25%)
- Less water absorption (0.1% vs. 0.3%)
- Tensile strength greater than 5 times other adhesive (41 MPa vs. 7 MPa)

Improvements Achieved and how this Impacts Product Performance:

The adhesive of the present invention outperforms current adhesives in many ways or every way that is of importance to the performance and durability of the vehicular camera:

Bond strength is nearly twice as strong as what is seen in previous adhesives.

Limits or avoids risk of bond break failures and makes the process much less sensitive to cure parameter precision.

Cure time is much faster which reduces cycle time.

Limits or avoids risk of bond failures and makes the process more robust by making it much less sensitive precise cure parameter.

Shrink after cure is nearly non-existent.

The previous adhesive continues to shrink some after the product is built since the adhesive is not considered to be fully cured until 48 hours after UV and thermal cure. The processes must offset the focus position in anticipation of such shrinkage.

Dimensional change from moisture absorption is nearly non-existent.

Testing of the adhesive of the present invention has shown that the bonded components bonded together using the adhesive of the present invention have retention forces of twice (or more) that of other tested adhesives, such as in tests where the bonded components are first stored at room temperature for approximately 30 days, or where the bonded components are thermally shocked via 10 days of cycling the parts between -40 degrees C. and 100 degrees C., or where the bonded components are first thermally shocked for ten days and then soaked for ten days at 85 degrees C. at 85% relative humidity.

The adhesive comprises a UV curable adhesive that preferably is a one-part, solvent free, filled adhesive comprising a modified epoxy resin. Such adhesives, as well as being UV curable, can also be cured thermally, such as by heat. For example, the adhesive preferably comprises an OB749 adhesive or AD VE 112203 or OB787 adhesive, both manufactured by Delo Industrial Adhesives of Sudbury, Mass. and Windach, Germany. Such adhesives are UV-/light-/heat curing adhesives having medium viscosity. Preferably, such UV light/heat curing adhesives have a viscosity in the range from about 5,000 mPa to about 150,000 mPa, preferably from about 10,000 mPa to 130,000 mPa, more preferably from about 12,000 mPa to about 120,000 mPa. Thus, the adhesive of the camera of the present invention comprises a UV curable and heat curable one-part filled adhesive having a viscosity at 23 degrees C. from about 5,000 mPa to about 150,000 mPa and comprising an epoxy resin. The AD VE 112203 or OB787 adhesive is substantially similar to the OB749 adhesive, but has a filler added to provide a preferred viscosity of the uncured adhesive. For example, the OB749 adhesive has a viscosity (at 23 degrees C.) of about 14,000 mPa, while the AD VE 112203 or OB787 adhesive has a viscosity (at 23 degrees C.) of about 115,000 mPa.

DELO®/DUALBOND® AD VE 112203 (a trade mark of and available from DELO Industrial Adhesives LLC of Sudbury, Mass.) or OB787 (the commercial product of the AD VE 112203 engineering development adhesive) com-

prises a UV-/light-/heat curing adhesive, medium viscosity, base modified epoxy resin, one-part, solvent free, filled, UV-/light-/heat curing adhesive formulated especially for fast fixing of components with high strength after irradiation and suitable for the bonding of metal, glass, plastic and other materials as well as for the coating, fixing or sealing of electronic components. It is normally used in a temperature range of -40 degrees C. to +150 degrees C., depending on the application. This adhesive is compliant with RoHS directive 2011/65/EU and is halogen-free according to IEC 61249-2-21. Curing of this adhesive is achieved with UV light or visible light, preferably in a wavelength range of about 320 nm to about 440 nm, or with heat. The light-curing mechanism and the heat-curing mechanism can be used independently. The color (cured in a layer thickness of approximate 0.1 mm) is white. The viscosity [mPa] at 23 degrees C., Brookfield rpm 7/5 is 115,000. The composition of DELO®•DUALBOND® AD VE 112203 or 06787 comprises vitreous Silica [CAS No. 60676-86-0 and %25-75], reaction product bisphenol-A-(epichlorhydrin); epoxy resin [CAS No. 25068-38-6 and %10-25], and Quartz (SiO₂) [CAS No. 14808-60-7 and %<2.5], and includes 7-oxabicyclo [4.1.0] hept-3-ylmethyl 7-oxabicyclo [4.1.0] heptane-3-carboxylate reaction product; bisphenol-A-(epichlorhydrin); epoxy resin.

Therefore, the present invention provides a camera assembly that utilizes such an adhesive to bond the lens relative to the imager or PCB. The vehicular camera comprises (i) a lens having a plurality of optical elements and disposed at a lens holder, (ii) a printed circuit board and (iii) an imager disposed at said printed circuit board. The printed circuit board may be held by a holding element and the lens holder may be attached at the holding element by a cured adhesive (such as shown in FIG. 5), or the lens holder may be attached at the printed circuit board by a cured adhesive (such as shown in FIG. 4). The adhesive is initially curable in an initial radiation curing process that comprises exposure to UV light, and the initially-cured adhesive is further curable to a further cured strength in a secondary thermal curing process. The adhesive is initially cured via the initial radiation curing process after the lens is brought into focus with the imager and is optically center-aligned therewith. The initially-cured adhesive, as cured via the initial radiation curing process, holds the lens optically center-aligned and in focus with the imager. After the initial radiation curing process, the lens holder, adhesively attached to one of the printed circuit board and the holding element, is moved to the secondary thermal curing process. When further cured via the secondary thermal curing process, the further-cured adhesive maintains focus and optical center-alignment of the lens with the imager for use of the camera in a vehicle.

Changes and modifications in the specifically described embodiments can be carried out without departing from the principles of the invention, which is intended to be limited only by the scope of the appended claims, as interpreted according to the principles of patent law including the doctrine of equivalents.

The invention claimed is:

1. A vehicular camera, said vehicular camera comprising: a lens comprising a plurality of optical elements, wherein the lens is accommodated in a lens barrel, and wherein the lens barrel comprises a cylindrical portion; a lens holder comprising a cylindrical passageway that accommodates at least a portion of the cylindrical portion of the lens barrel;

a printed circuit board; an imager disposed at the printed circuit board; a flexible electrical ribbon cable with one end electrically connecting at the printed circuit board and with another distal end electrically terminating at an electrical connector of the flexible electrical ribbon cable; wherein said vehicular camera utilizes an adhesive to hold the lens optically aligned with the imager; wherein the adhesive is initially curable in an initial radiation curing process for an initial-cure time period of less than 10 seconds, and wherein the initially-cured adhesive is further curable to a further-cured strength in a secondary curing process; wherein the adhesive is initially cured via the initial radiation curing process after the lens is optically aligned with the imager; wherein the initially-cured adhesive, as cured via the initial radiation curing process, holds the lens optically aligned with the imager; wherein, as further cured via the secondary curing process for a further-cure time period that is longer than the initial-cure time period, the further-cured adhesive maintains optical alignment of the lens with the imager for use of said vehicular camera in a vehicle; wherein the adhesive, in its uncured state, comprises a one-part, filled adhesive; and wherein the further-cured adhesive maintains at least 70% strength of bond after being exposed for 1000 hours to a temperature of 85 degrees Celsius and a humidity of 85% RH.

2. The vehicular camera of claim 1, wherein the lens barrel is threadedly attached at the lens holder, and wherein, with the lens barrel threadedly attached at the lens holder, optical alignment of the lens relative to the imager is achieved.

3. The vehicular camera of claim 1, wherein the lens barrel is adhesively attached at the lens holder, and wherein, with the lens barrel adhesively attached at the lens holder, optical alignment of the lens relative to the imager is achieved.

4. The vehicular camera of claim 1, wherein the lens barrel is threadedly and adhesively attached at the lens holder, and wherein, with the lens barrel threadedly and adhesively attached at the lens holder, optical alignment of the lens relative to the imager is achieved.

5. The vehicular camera of claim 1, wherein the printed circuit board is attached at the lens holder, and wherein, with the printed circuit board attached at the lens holder, optical alignment of the lens relative to the imager is achieved.

6. The vehicular camera of claim 1, wherein the printed circuit board is mechanically attached at the lens holder, and wherein, with the printed circuit board mechanically attached at the lens holder, optical alignment of the lens relative to the imager is achieved.

7. The vehicular camera of claim 1, wherein the printed circuit board is mechanically attached at the lens holder via at least one fastener, and wherein, with the printed circuit board mechanically attached at the lens holder via at least one fastener, optical alignment of the lens relative to the imager is achieved.

8. The vehicular camera of claim 1, wherein the printed circuit board is mechanically attached at the lens holder via two screw fasteners, and wherein, with the printed circuit board mechanically attached at the lens holder via two screw fasteners, optical alignment of the lens relative to the imager is achieved.

9. The vehicular camera of claim 1, wherein the further-cure time period is at least 30 seconds.

11

10. The vehicular camera of claim 1, wherein the lens barrel comprises an annular flange that circumscribes and extends radially from the cylindrical portion of the lens holder.

11. The vehicular camera of claim 1, wherein the adhesive, in its uncured state, has a viscosity at 23 degrees Celsius between 5,000 mPa and 150,000 mPa.

12. The vehicular camera of claim 1, wherein the lens holder is adapted for attachment to a camera housing.

13. The vehicular camera of claim 1, wherein lens resolution of the lens meets but does not exceed a resolution determined by size of a sensing surface of the imager.

14. The vehicular camera of claim 1, wherein the lens omits achromatic lenses.

15. The vehicular camera of claim 1, wherein the lens employs digital chromatic correction based on a predetermined chromatic aberration measurement.

16. The vehicular camera of claim 1, wherein optical alignment of the lens relative to the imager is achieved robotically.

17. The vehicular camera of claim 1, wherein the adhesive comprises one selected from the group consisting of (i) a Delo OB749 adhesive, (ii) a Delo AD VE 112203 adhesive and (iii) a Delo OB787 adhesive.

18. The vehicular camera of claim 1, wherein said vehicular camera, when installed and used in the vehicle, captures image data for use by a rear vision system of the vehicle.

19. The vehicular camera of claim 1, wherein the secondary curing process comprises thermal curing.

20. The vehicular camera of claim 1, wherein the secondary curing process comprises moisture curing.

21. The vehicular camera of claim 1, wherein the secondary curing process comprises radiation curing.

22. The vehicular camera of claim 1, wherein said vehicular camera, when installed and used in the vehicle, captures image data for use by a forward vision system of the vehicle.

23. The vehicular camera of claim 1, wherein said vehicular camera, when installed and used in the vehicle, captures image data for use by an automatic high-beam control of the vehicle.

24. The vehicular camera of claim 1, wherein the adhesive bonds to PBT/PC and PBT plastics.

25. The vehicular camera of claim 1, wherein the adhesive bonds to an FR4 PCB.

26. The vehicular camera of claim 1, wherein the adhesive bonds to zinc.

27. The vehicular camera of claim 1, wherein the adhesive bonds to aluminum.

28. The vehicular camera of claim 1, wherein the adhesive, in its further-cured state, has a bond shear strength greater than 1,000 PSI.

29. The vehicular camera of claim 28, wherein bond shear strength of the adhesive, in its further-cured state, reduces less than 60% at 85 degrees Celsius.

30. The vehicular camera of claim 28, wherein the adhesive, in its further-cured state, has a glass transition temperature greater than 90 degrees Celsius.

31. The vehicular camera of claim 28, wherein the adhesive, in its further-cured state, has greater than 50 Shore D hardness.

32. The vehicular camera of claim 28, wherein the adhesive is halogen-free.

33. The vehicular camera of claim 1, wherein the initial radiation curing process comprises exposure to UV light for the initial-cure time period.

34. The vehicular camera of claim 33, wherein the initial-cure time period is less than 7 seconds.

12

35. A vehicular camera, said vehicular camera comprising:

a lens comprising a plurality of optical elements, wherein the lens is accommodated in a lens barrel, and wherein the lens barrel comprises a cylindrical portion;

a lens holder comprising a cylindrical passageway that accommodates at least a portion of the cylindrical portion of the lens barrel;

a printed circuit board;

a CMOS imager disposed at the printed circuit board;

a flexible electrical ribbon cable with one end electrically connecting at the printed circuit board and with another distal end electrically terminating at an electrical connector of the flexible electrical ribbon cable;

wherein said vehicular camera utilizes an adhesive to hold the lens optically aligned with the CMOS imager;

wherein the adhesive is initially curable in an initial radiation curing process for an initial-cure time period of less than 10 seconds, and wherein the initially-cured adhesive is further curable to a further-cured strength in a secondary curing process;

wherein the adhesive is initially cured via the initial radiation curing process after the lens is optically aligned with the CMOS imager;

wherein the initially-cured adhesive, as cured via the initial radiation curing process, holds the lens optically aligned with the CMOS imager;

wherein, as further cured via the secondary curing process for a further-cure time period that is longer than the initial-cure time period, the further-cured adhesive maintains optical alignment of the lens with the CMOS imager for use of said vehicular camera in a vehicle; wherein the adhesive, in its uncured state, comprises a one-part, filled adhesive;

wherein the further-cured adhesive maintains at least 70% strength of bond after being exposed for 1000 hours to a temperature of 85 degrees Celsius and a humidity of 85% RH; and

wherein said vehicular camera, when installed and used in the vehicle, captures image data for use by an automatic high-beam control of the vehicle.

36. The vehicular camera of claim 35, wherein the lens barrel is threadedly attached at the lens holder, and wherein, with the lens barrel threadedly attached at the lens holder, optical alignment of the lens relative to the CMOS imager is achieved.

37. The vehicular camera of claim 35, wherein the lens barrel is adhesively attached at the lens holder, and wherein, with the lens barrel adhesively attached at the lens holder, optical alignment of the lens relative to the CMOS imager is achieved.

38. The vehicular camera of claim 35, wherein the lens barrel is threadedly and adhesively attached at the lens holder, and wherein, with the lens barrel threadedly and adhesively attached at the lens holder, optical alignment of the lens relative to the CMOS imager is achieved.

39. The vehicular camera of claim 35, wherein the printed circuit board is attached at the lens holder, and wherein, with the printed circuit board attached at the lens holder, optical alignment of the lens relative to the CMOS imager is achieved.

40. The vehicular camera of claim 35, wherein the printed circuit board is mechanically attached at the lens holder, and wherein, with the printed circuit board mechanically attached at the lens holder, optical alignment of the lens relative to the CMOS imager is achieved.

13

41. The vehicular camera of claim 35, wherein the printed circuit board is mechanically attached at the lens holder via at least one fastener, and wherein, with the printed circuit board mechanically attached at the lens holder via at least one fastener, optical alignment of the lens relative to the CMOS imager is achieved.

42. The vehicular camera of claim 35, wherein optical alignment of the lens relative to the CMOS imager is achieved robotically.

43. The vehicular camera of claim 35, wherein the further-cure time period is at least 30 seconds.

44. The vehicular camera of claim 35, wherein the lens barrel comprises an annular flange that circumscribes and extends radially from the cylindrical portion of the lens holder.

45. The vehicular camera of claim 35, wherein the adhesive, in its uncured state, has a viscosity at 23 degrees Celsius between 5,000 mPa and 150,000 mPa.

46. The vehicular camera of claim 35, wherein the adhesive comprises one selected from the group consisting of (i) a Delo OB749 adhesive, (ii) a Delo AD VE 112203 adhesive and (iii) a Delo OB787 adhesive.

47. The vehicular camera of claim 35, wherein the secondary curing process comprises thermal curing.

48. The vehicular camera of claim 35, wherein the secondary curing process comprises moisture curing.

49. The vehicular camera of claim 35, wherein the secondary curing process comprises radiation curing.

50. The vehicular camera of claim 35, wherein the initial radiation curing process comprises exposure to UV light for the initial-cure time period.

51. The vehicular camera of claim 35, wherein the adhesive, in its further-cured state, has a bond shear strength greater than 1,000 PSI.

52. The vehicular camera of claim 51, wherein bond shear strength of the adhesive, in its further-cured state, reduces less than 60% at 85 degrees Celsius.

53. The vehicular camera of claim 51, wherein the adhesive, in its further-cured state, has a glass transition temperature greater than 90 degrees Celsius.

54. The vehicular camera of claim 51, wherein the adhesive, in its further-cured state, has greater than 50 Shore D hardness.

55. The vehicular camera of claim 51, wherein the adhesive is halogen-free.

56. A vehicular camera, said vehicular camera comprising:

a lens comprising a plurality of optical elements, wherein the lens is accommodated in a lens barrel, and wherein the lens barrel comprises a cylindrical portion;

a lens holder comprising a cylindrical passageway that accommodates at least a portion of the cylindrical portion of the lens barrel;

a printed circuit board;

a CMOS imager disposed at the printed circuit board;

a flexible electrical ribbon cable with one end electrically connecting at the printed circuit board and with another distal end electrically terminating at an electrical connector of the flexible electrical ribbon cable;

wherein said vehicular camera utilizes an adhesive to hold the lens optically aligned with the CMOS imager;

wherein the adhesive is initially curable in an initial radiation curing process for an initial-cure time period of less than 10 seconds, and wherein the initially-cured adhesive is further curable to a further-cured strength in a secondary curing process;

14

wherein the adhesive is initially cured via the initial radiation curing process after the lens is optically aligned with the CMOS imager;

wherein the initially-cured adhesive, as cured via the initial radiation curing process, holds the lens optically aligned with the CMOS imager;

wherein, as further cured via the secondary curing process for a further-cure time period that is longer than the initial-cure time period, the further-cured adhesive maintains optical alignment of the lens with the CMOS imager for use of said vehicular camera in a vehicle;

wherein the adhesive, in its uncured state, comprises a one-part, filled adhesive;

wherein the further-cured adhesive maintains at least 70% strength of bond after being exposed for 1000 hours to a temperature of 85 degrees Celsius and a humidity of 85% RH; and

wherein said vehicular camera, when installed and used in the vehicle, captures image data for use by a rear vision system of the vehicle.

57. The vehicular camera of claim 56, wherein the lens barrel is threadedly attached at the lens holder, and wherein, with the lens barrel threadedly attached at the lens holder, optical alignment of the lens relative to the CMOS imager is achieved.

58. The vehicular camera of claim 56, wherein the lens barrel is adhesively attached at the lens holder, and wherein, with the lens barrel adhesively attached at the lens holder, optical alignment of the lens relative to the CMOS imager is achieved.

59. The vehicular camera of claim 56, wherein the lens barrel is threadedly and adhesively attached at the lens holder, and wherein, with the lens barrel threadedly and adhesively attached at the lens holder, optical alignment of the lens relative to the CMOS imager is achieved.

60. The vehicular camera of claim 56, wherein the printed circuit board is attached at the lens holder, and wherein, with the printed circuit board attached at the lens holder, optical alignment of the lens relative to the CMOS imager is achieved.

61. The vehicular camera of claim 56, wherein the printed circuit board is mechanically attached at the lens holder, and wherein, with the printed circuit board mechanically attached at the lens holder, optical alignment of the lens relative to the CMOS imager is achieved.

62. The vehicular camera of claim 56, wherein the printed circuit board is mechanically attached at the lens holder via at least one fastener, and wherein, with the printed circuit board mechanically attached at the lens holder via at least one fastener, optical alignment of the lens relative to the CMOS imager is achieved.

63. The vehicular camera of claim 56, wherein optical alignment of the lens relative to the CMOS imager is achieved robotically.

64. The vehicular camera of claim 56, wherein the further-cure time period is at least 30 seconds.

65. The vehicular camera of claim 56, wherein the lens barrel comprises an annular flange that circumscribes and extends radially from the cylindrical portion of the lens holder.

66. The vehicular camera of claim 56, wherein the adhesive, in its uncured state, has a viscosity at 23 degrees Celsius between 5,000 mPa and 150,000 mPa.

67. The vehicular camera of claim 56, wherein the adhesive comprises one selected from the group consisting of (i) a Delo OB749 adhesive, (ii) a Delo AD VE 112203 adhesive and (iii) a Delo OB787 adhesive.

68. The vehicular camera of claim 56, wherein the secondary curing process comprises thermal curing.

69. The vehicular camera of claim 56, wherein the secondary curing process comprises moisture curing.

70. The vehicular camera of claim 56, wherein the secondary curing process comprises radiation curing. 5

71. The vehicular camera of claim 56, wherein the initial radiation curing process comprises exposure to UV light for the initial-cure time period.

72. The vehicular camera of claim 56, wherein the adhesive, in its further-cured state, has a bond shear strength greater than 1,000 PSI. 10

73. The vehicular camera of claim 72, wherein bond shear strength of the adhesive, in its further-cured state, reduces less than 60% at 85 degrees Celsius. 15

74. The vehicular camera of claim 72, wherein the adhesive, in its further-cured state, has a glass transition temperature greater than 90 degrees Celsius.

75. The vehicular camera of claim 72, wherein the adhesive, in its further-cured state, has greater than 50 Shore D hardness. 20

76. The vehicular camera of claim 72, wherein the adhesive is halogen-free.

* * * * *

UNITED STATES PATENT AND TRADEMARK OFFICE
CERTIFICATE OF CORRECTION

PATENT NO. : 10,674,053 B2
APPLICATION NO. : 16/571633
DATED : June 2, 2020
INVENTOR(S) : Brian J. Winden et al.

Page 1 of 1

It is certified that error appears in the above-identified patent and that said Letters Patent is hereby corrected as shown below:

In the Specification

Column 2

Line 13, "Sudbury, M A" should be --Sudbury, MA--

Column 6

Line 43, "(+/-20p)." should be --(+/-20 μ).--

Column 9

Line 19, "06787" should be --OB787--

Signed and Sealed this
Thirtieth Day of June, 2020

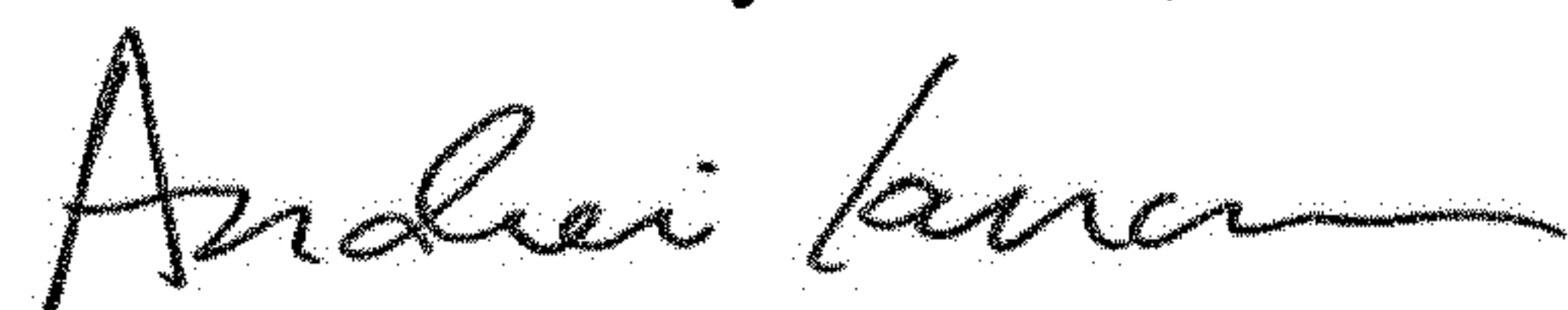

Andrei Iancu
Director of the United States Patent and Trademark Office