

US010673282B2

(12) **United States Patent**  
**Campanella et al.**

(10) **Patent No.:** **US 10,673,282 B2**  
(45) **Date of Patent:** **\*Jun. 2, 2020**

(54) **TUNABLE WIRELESS ENERGY TRANSFER SYSTEMS**

(71) Applicant: **WiTricity Corporation**, Watertown, MA (US)

(72) Inventors: **Andrew J. Campanella**, Somerville, MA (US); **Herbert T. Lou**, Berkeley, CA (US); **Morris P. Kesler**, Bedford, MA (US); **Katherine L. Hall**, Arlington, MA (US); **Ron Fiorello**, Tewksbury, MA (US); **Aristeidis Karalis**, Boston, MA (US)

(73) Assignee: **WiTricity Corporation**, Watertown, MA (US)

(\* ) Notice: Subject to any disclaimer, the term of this patent is extended or adjusted under 35 U.S.C. 154(b) by 0 days.

This patent is subject to a terminal disclaimer.

(21) Appl. No.: **16/246,764**

(22) Filed: **Jan. 14, 2019**

(65) **Prior Publication Data**

US 2019/0252920 A1 Aug. 15, 2019

**Related U.S. Application Data**

(63) Continuation of application No. 15/134,827, filed on Apr. 21, 2016, now Pat. No. 10,218,224, which is a (Continued)

(51) **Int. Cl.**  
**H02J 7/00** (2006.01)  
**H02J 50/12** (2016.01)  
(Continued)

(52) **U.S. Cl.**  
CPC ..... **H02J 50/12** (2016.02); **H01F 38/14** (2013.01); **H01Q 7/00** (2013.01); **H03H 7/40** (2013.01); **B60L 2200/26** (2013.01)

(58) **Field of Classification Search**  
CPC ... Y02T 10/7005; Y02T 90/14; Y02T 10/705; Y02T 10/7088; Y02E 60/12  
See application file for complete search history.

(56) **References Cited**

U.S. PATENT DOCUMENTS

645,576 A 3/1900 Tesla  
649,621 A 5/1900 Tesla  
(Continued)

FOREIGN PATENT DOCUMENTS

CA 142352 8/1912  
CN 102239633 11/2011  
(Continued)

OTHER PUBLICATIONS

“Intel CTO Says Gap between Humans, Machines Will Close by 2050”, *Intel News Release*, (See intel.com/.../20080821comp.htm?iid=S . . . ) (Printed Nov. 6, 2009).

(Continued)

*Primary Examiner* — Arun C Williams

(74) *Attorney, Agent, or Firm* — Fish & Richardson P.C.

(57) **ABSTRACT**

This application includes a source for a wireless power transfer system including: sensing and measurement circuitry configured to process signals associated with a source resonator and a source impedance matching network including a tunable component; a PWM generator coupled with power transistors of an amplifier coupled with the source impedance matching network, wherein the PWM generator is configured to control a driving signal to drive the source resonator using the power transistors; and a controller coupled with the sensing and measurement circuitry to receive measured signals, wherein the controller is configured to control a component value or an operating point of at least one of the tunable component(s), and the controller is configured to modify operation of the PWM generator based on the measured signals to modify at least a phase of

(Continued)

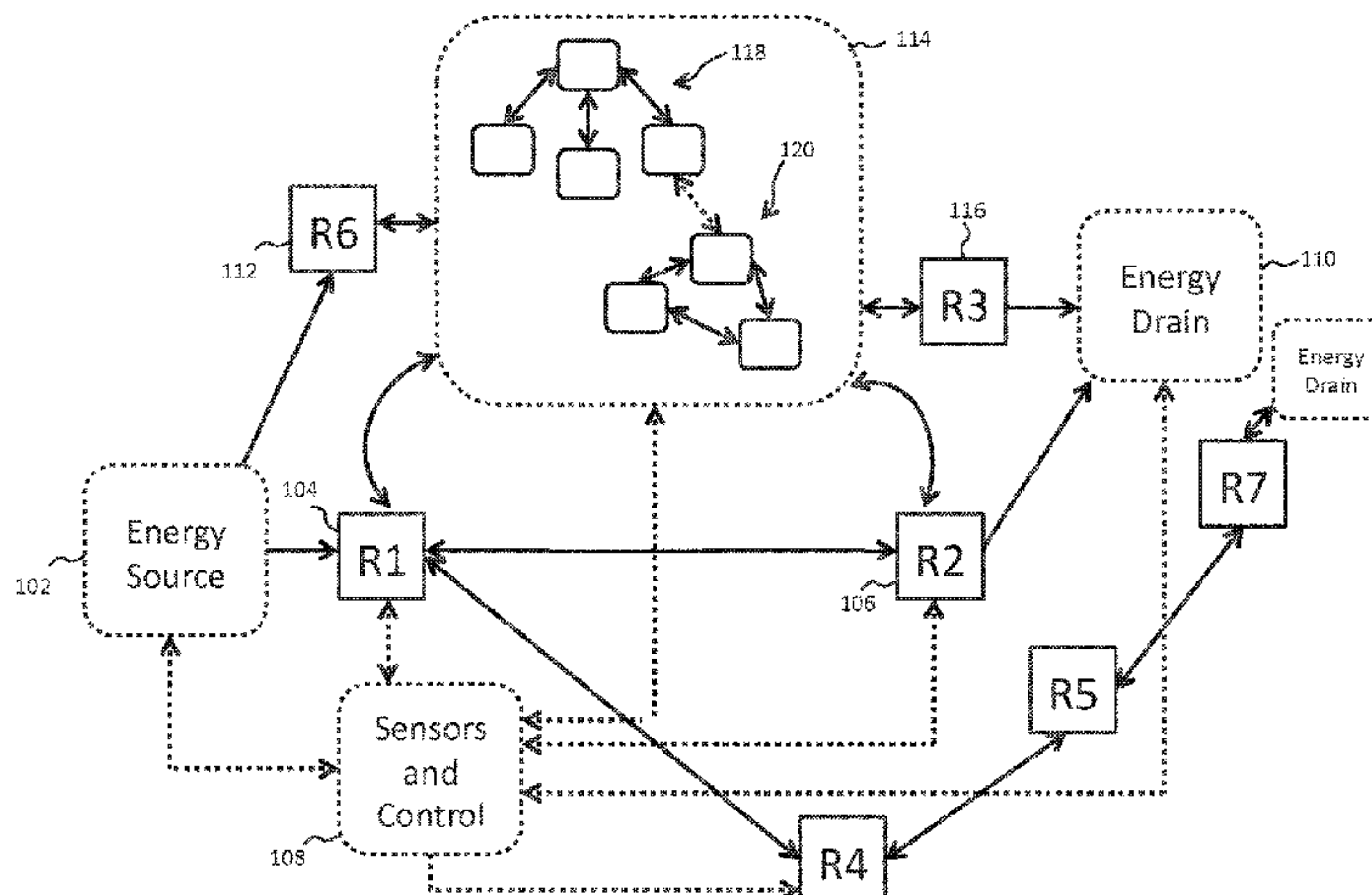



the driving signal while changing power delivered to the source resonator.

**21 Claims, 16 Drawing Sheets**

**Related U.S. Application Data**

continuation of application No. 14/140,446, filed on Dec. 24, 2013, now abandoned, which is a continuation of application No. 12/986,018, filed on Jan. 6, 2011, now Pat. No. 8,643,326, which is a continuation-in-part of application No. 12/789,611, filed on May 28, 2010, now Pat. No. 8,598,743, which is a continuation-in-part of application No. 12/770,137, filed on Apr. 29, 2010, now abandoned, which is a continuation-in-part of application No. 12/767,633, filed on Apr. 26, 2010, now Pat. No. 8,497,601, which is a continuation-in-part of application No. 12/759,047, filed on Apr. 13, 2010, now Pat. No. 9,601,261, which is a continuation-in-part of application No. 12/757,716, filed on Apr. 9, 2010, now abandoned, which is a continuation-in-part of application No. 12/749,571, filed on Mar. 30, 2010, now Pat. No. 8,692,412, which is a continuation-in-part of application No. 12/639,489, filed on Dec. 16, 2009, now Pat. No. 8,410,636, and a continuation-in-part of application No. 12/647,705, filed on Dec. 28, 2009, now Pat. No. 8,482,158, and a continuation-in-part of application No. 12/567,716, filed on Sep. 25, 2009, now Pat. No. 8,461,719, said application No. 12/757,716 is a continuation-in-part of application No. 12/721,118, filed on Mar. 10, 2010, now Pat. No. 8,723,366, which is a continuation-in-part of application No. 12/705,582, filed on Feb. 13, 2010, now Pat. No. 9,184,595.

(60) Provisional application No. 61/292,768, filed on Jan. 6, 2010, provisional application No. 61/173,747, filed on Apr. 29, 2009, provisional application No. 61/172,633, filed on Apr. 24, 2009, provisional application No. 61/100,721, filed on Sep. 27, 2008, provisional application No. 61/108,743, filed on Oct. 27, 2008, provisional application No. 61/147,386, filed on Jan. 26, 2009, provisional application No. 61/152,086, filed on Feb. 12, 2009, provisional application No. 61/178,508, filed on May 15, 2009, provisional application No. 61/182,768, filed on Jun. 1, 2009, provisional application No. 61/121,159, filed on Dec. 9, 2008, provisional application No. 61/142,977, filed on Jan. 7, 2009, provisional application No. 61/142,885, filed on Jan. 6, 2009, provisional application No. 61/142,796, filed on Jan. 6, 2009, provisional application No. 61/142,889, filed on Jan. 6, 2009, provisional application No. 61/142,880, filed on Jan. 6, 2009, provisional application No. 61/142,818, filed on Jan. 6, 2009, provisional application No. 61/142,887, filed on Jan. 6, 2009, provisional application No. 61/156,764, filed on Mar. 2, 2009, provisional application No. 61/143,058, filed on Jan. 7, 2009, provisional application No. 61/163,695, filed on Mar. 26, 2009, provisional application No. 61/169,240, filed on Apr. 14, 2009, provisional application No. 61/152,390, filed on Feb. 13, 2009.

(51) **Int. Cl.**  
*H01Q 7/00* (2006.01)  
*H03H 7/40* (2006.01)  
*H01F 38/14* (2006.01)

(56) **References Cited**

U.S. PATENT DOCUMENTS

787,412	A	4/1905	Tesla	
1,119,732	A	12/1914	Tesla	
2,133,494	A	10/1938	Waters	
3,517,350	A	6/1970	Beaver	
3,535,543	A	10/1970	Dailey	
3,780,425	A	12/1973	Penn et al.	
3,871,176	A	3/1975	Schukei	
4,088,999	A	5/1978	Fletcher et al.	
4,095,998	A	6/1978	Hanson	
4,180,795	A	12/1979	Matsuda et al.	
4,280,129	A	7/1981	Wells	
4,450,431	A	5/1984	Hochstein	
4,588,978	A	5/1986	Allen	
4,745,342	A *	5/1988	Andresen .....	H05B 41/2851 315/174
4,873,480	A *	10/1989	Lafferty .....	G05F 1/67 323/299
5,027,709	A	7/1991	Slagle	
5,033,295	A	7/1991	Schmid et al.	
5,034,658	A	7/1991	Hiering et al.	
5,053,774	A	10/1991	Schuermann et al.	
5,070,293	A	12/1991	Ishii et al.	
5,118,997	A	6/1992	El-Hamamsy	
5,216,402	A	6/1993	Carosa	
5,229,652	A	7/1993	Hough	
5,287,112	A	2/1994	Schuermann	
5,341,083	A	8/1994	Klontz et al.	
5,367,242	A	11/1994	Hulman	
5,374,930	A	12/1994	Schuermann	
5,408,209	A	4/1995	Tanzer et al.	
5,437,057	A	7/1995	Richley et al.	
5,455,467	A	10/1995	Young et al.	
5,493,691	A	2/1996	Barrett	
5,522,856	A	6/1996	Reineman	
5,528,113	A	6/1996	Boys et al.	
5,541,604	A	7/1996	Meier	
5,550,452	A	8/1996	Shirai et al.	
5,565,763	A	10/1996	Arrendale et al.	
5,630,835	A	5/1997	Brownlee	
5,697,956	A	12/1997	Bornzin	
5,703,461	A	12/1997	Minoshima et al.	
5,703,573	A	12/1997	Fujimoto et al.	
5,710,413	A	1/1998	King et al.	
5,742,471	A	4/1998	Barbee, Jr. et al.	
5,821,728	A	10/1998	Sshwind	
5,821,731	A	10/1998	Kuki et al.	
5,864,323	A	1/1999	Berthon	
5,898,579	A	4/1999	Boys et al.	
5,903,134	A	5/1999	Takeuchi	
5,923,544	A	7/1999	Urano	
5,940,509	A	8/1999	Jovanovich et al.	
5,957,956	A	9/1999	Kroll et al.	
5,959,245	A	9/1999	Moe et al.	
5,986,895	A	11/1999	Stewart et al.	
5,993,996	A	11/1999	Firsich	
5,999,308	A	12/1999	Nelson et al.	
6,012,659	A	1/2000	Nakazawa et al.	
6,047,214	A	4/2000	Mueller et al.	
6,066,163	A	5/2000	John	
6,067,473	A	5/2000	Greeninger et al.	
6,108,579	A	8/2000	Snell et al.	
6,127,799	A	10/2000	Krishnan	
6,176,433	B1	1/2001	Uesaka et al.	
6,184,651	B1	2/2001	Fernandez et al.	
6,207,887	B1	3/2001	Bass et al.	
6,232,841	B1	5/2001	Bartlett et al.	
6,238,387	B1	5/2001	Miller, III	
6,252,762	B1	6/2001	Amatucci	
6,436,299	B1	8/2002	Baarman et al.	



(56)

## References Cited

## U.S. PATENT DOCUMENTS

6,450,946 B1	9/2002	Forsell	7,518,267 B2	4/2009	Baarman
6,452,465 B1	9/2002	Brown et al.	7,521,890 B2	4/2009	Lee et al.
6,459,218 B2	10/2002	Boys et al.	7,525,283 B2	4/2009	Cheng et al.
6,473,028 B1	10/2002	Luc	7,545,337 B2	6/2009	Guenther
6,483,202 B1	11/2002	Boys	7,554,316 B2	6/2009	Stevens et al.
6,515,878 B1	2/2003	Meins et al.	7,599,743 B2	10/2009	Hassler, Jr. et al.
6,535,133 B2	3/2003	Gohara	7,615,936 B2	11/2009	Baarman et al.
6,561,975 B1	5/2003	Pool et al.	7,639,514 B2	12/2009	Baarman
6,563,425 B2	5/2003	Nicholson et al.	7,741,734 B2	6/2010	Joannopoulos et al.
6,597,076 B2	7/2003	Scheible et al.	7,795,708 B2	9/2010	Katti
6,609,023 B1	8/2003	Fischell et al.	7,825,543 B2	11/2010	Karalis et al.
6,631,072 B1	10/2003	Paul et al.	7,825,544 B2	11/2010	Jansen et al.
6,650,227 B1	11/2003	Bradin	7,835,417 B2	11/2010	Heideman et al.
6,664,770 B1	12/2003	Bartels	7,843,288 B2	11/2010	Lee et al.
6,673,250 B2	1/2004	Kuennen et al.	7,844,306 B2	11/2010	Shearer et al.
6,683,256 B2	1/2004	Kao	7,863,859 B2	1/2011	Soar
6,696,647 B2	2/2004	Ono et al.	7,880,337 B2	2/2011	Farkas
6,703,921 B1	3/2004	Wuidart et al.	7,884,697 B2	2/2011	Wei et al.
6,731,071 B2	5/2004	Baarman	7,885,050 B2	2/2011	Lee
6,749,119 B2	6/2004	Scheible et al.	7,919,886 B2	4/2011	Tanaka
6,772,011 B2	8/2004	Dolgin	7,923,870 B2	4/2011	Jin
6,798,716 B1	9/2004	Charych	7,932,798 B2	4/2011	Tolle et al.
6,803,744 B1	10/2004	Sabo	7,948,209 B2	5/2011	Jung
6,806,649 B2	10/2004	Mollema et al.	7,952,322 B2	5/2011	Partovi et al.
6,812,645 B2	11/2004	Baarman	7,963,941 B2	6/2011	Wilk
6,825,620 B2	11/2004	Kuennen et al.	7,969,045 B2	6/2011	Schmidt et al.
6,831,417 B2	12/2004	Baarman	7,994,880 B2	8/2011	Chen et al.
6,839,035 B1	1/2005	Addonisio et al.	7,999,506 B1	8/2011	Hollar et al.
6,844,702 B2	1/2005	Giannopoulos et al.	8,022,576 B2	9/2011	Joannopoulos et al.
6,856,291 B2	2/2005	Mickle et al.	8,035,255 B2	10/2011	Kurs et al.
6,858,970 B2	2/2005	Malkin et al.	8,076,800 B2	12/2011	Joannopoulos et al.
6,906,495 B2	6/2005	Cheng et al.	8,076,801 B2	12/2011	Karalis et al.
6,917,163 B2	7/2005	Baarman	8,084,889 B2	12/2011	Joannopoulos et al.
6,917,431 B2	7/2005	Soljacic et al.	8,097,983 B2	1/2012	Karalis et al.
6,937,130 B2	8/2005	Scheible et al.	8,106,539 B2	1/2012	Schatz et al.
6,960,968 B2	11/2005	Odendaal et al.	8,115,448 B2	2/2012	John
6,961,619 B2	11/2005	Casey	8,131,378 B2	3/2012	Greenberg et al.
6,967,462 B1	11/2005	Landis	8,178,995 B2	5/2012	Amano et al.
6,975,198 B2	12/2005	Baarman	8,193,769 B2	6/2012	Azancot et al.
6,988,026 B2	1/2006	Breed et al.	8,212,414 B2	7/2012	Howard et al.
7,027,311 B2	4/2006	Vanderelli et al.	8,260,200 B2	9/2012	Shimizu et al.
7,035,076 B1	4/2006	Stevenson	8,304,935 B2	11/2012	Karalis et al.
7,042,196 B2	5/2006	Ka-Lai et al.	8,324,759 B2	12/2012	Karalis et al.
7,069,064 B2	6/2006	Govorgian et al.	8,334,620 B2	12/2012	Park et al.
7,084,605 B2	8/2006	Mickle et al.	8,362,651 B2	1/2013	Hamam et al.
7,116,200 B2	10/2006	Baarman et al.	8,395,282 B2	3/2013	Joannopoulos et al.
7,118,240 B2	10/2006	Baarman et al.	8,395,283 B2	3/2013	Joannopoulos et al.
7,126,450 B2	10/2006	Baarman et al.	8,400,017 B2	3/2013	Kurs et al.
7,127,293 B2	10/2006	MacDonald	8,400,018 B2	3/2013	Joannopoulos et al.
7,132,918 B2	11/2006	Baarman et al.	8,400,019 B2	3/2013	Joannopoulos et al.
7,147,604 B1	12/2006	Allen et al.	8,400,020 B2	3/2013	Joannopoulos et al.
7,180,248 B2	2/2007	Kuennen et al.	8,400,021 B2	3/2013	Joannopoulos et al.
7,191,007 B2	3/2007	Desai et al.	8,400,022 B2	3/2013	Joannopoulos et al.
7,193,418 B2	3/2007	Freytag	8,400,023 B2	3/2013	Joannopoulos et al.
D541,322 S	4/2007	Garrett et al.	8,400,024 B2	3/2013	Joannopoulos et al.
7,212,414 B2	5/2007	Baarman	8,410,636 B2	4/2013	Kurs et al.
7,233,137 B2	6/2007	Nakamura et al.	8,441,154 B2	5/2013	Karalis et al.
D545,855 S	7/2007	Garrett et al.	8,457,547 B2	6/2013	Meskens
7,239,110 B2	7/2007	Cheng et al.	8,461,719 B2	6/2013	Kesler et al.
7,248,017 B2	7/2007	Cheng et al.	8,461,720 B2	6/2013	Kurs et al.
7,251,527 B2	7/2007	Lyden	8,461,721 B2	6/2013	Karalis et al.
7,288,918 B2	10/2007	DiStefano	8,461,722 B2	6/2013	Kurs et al.
7,340,304 B2	3/2008	MacDonald	8,461,817 B2	6/2013	Martin et al.
7,375,492 B2	5/2008	Calhoon et al.	8,466,583 B2	6/2013	Karalis et al.
7,375,493 B2	5/2008	Calhoon et al.	8,471,410 B2	6/2013	Karalis et al.
7,378,817 B2	5/2008	Calhoon et al.	8,476,788 B2	7/2013	Karalis et al.
7,382,636 B2	6/2008	Baarman et al.	8,482,157 B2	7/2013	Cook et al.
7,385,357 B2	6/2008	Kuennen et al.	8,482,158 B2	7/2013	Kurs et al.
7,443,135 B2	10/2008	Cho	8,487,480 B1	7/2013	Kesler et al.
7,462,951 B1	12/2008	Baarman	8,497,601 B2	7/2013	Hall et al.
7,466,213 B2	12/2008	Lobl et al.	8,552,592 B2	10/2013	Schatz et al.
7,471,062 B2	12/2008	Bruning	8,569,914 B2	10/2013	Karalis et al.
7,474,058 B2	1/2009	Baarman	8,587,153 B2	11/2013	Schatz et al.
7,492,247 B2	2/2009	Schmidt et al.	8,587,155 B2	11/2013	Giler et al.
7,514,818 B2	4/2009	Abe et al.	8,598,743 B2	12/2013	Hall et al.
			8,618,696 B2	12/2013	Karalis et al.
			8,629,578 B2	1/2014	Kurs et al.
			8,643,326 B2	2/2014	Campanella et al.
			2002/0032471 A1	3/2002	Loftin et al.



(56)

## References Cited

## U.S. PATENT DOCUMENTS

2002/0105343	A1	8/2002	Scheible et al.	2006/0238365	A1	10/2006	Vecchione et al.
2002/0118004	A1	8/2002	Scheible et al.	2006/0270440	A1	11/2006	Shearer et al.
2002/0130642	A1	9/2002	Ettes et al.	2006/0281435	A1	12/2006	Shearer et al.
2002/0167294	A1	11/2002	Odaohhara	2007/0010295	A1	1/2007	Greene et al.
2003/0038641	A1	2/2003	Scheible	2007/0013483	A1	1/2007	Stewart
2003/0062794	A1	4/2003	Scheible et al.	2007/0016089	A1	1/2007	Fischell et al.
2003/0062980	A1	4/2003	Scheible et al.	2007/0021140	A1	1/2007	Keyes, IV et al.
2003/0071034	A1	4/2003	Thompson et al.	2007/0024246	A1	2/2007	Flaughner
2003/0124050	A1	7/2003	Yadav et al.	2007/0064406	A1	3/2007	Heart
2003/0126948	A1	7/2003	Yadav et al.	2007/0069687	A1	3/2007	Suzuki
2003/0160590	A1	8/2003	Schaefer et al.	2007/0096875	A1	5/2007	Waterhouse et al.
2003/0199778	A1	10/2003	Mickle et al.	2007/0105429	A1	5/2007	Kohl et al.
2003/0214255	A1	11/2003	Baarman et al.	2007/0117596	A1	5/2007	Greene et al.
2004/0000974	A1	1/2004	Odenaal et al.	2007/0126650	A1	6/2007	Guenther
2004/0026998	A1	2/2004	Henriott et al.	2007/0145830	A1	6/2007	Lee et al.
2004/0100338	A1	5/2004	Clark	2007/0164839	A1	7/2007	Naito
2004/0113847	A1	6/2004	Qi et al.	2007/0171681	A1	7/2007	Baarman
2004/0130425	A1	7/2004	Dayan et al.	2007/0176840	A1	8/2007	Pristas et al.
2004/0130915	A1	7/2004	Baarman	2007/0178945	A1	8/2007	Cook et al.
2004/0130916	A1	7/2004	Baarman	2007/0182367	A1	8/2007	Partovi
2004/0142733	A1	7/2004	Parise	2007/0182367	A1	8/2007	Partovi
2004/0150934	A1	8/2004	Baarman	2007/0208263	A1	9/2007	John et al.
2004/0189246	A1	9/2004	Bulai et al.	2007/0222542	A1	9/2007	Joannopoulos et al.
2004/0201361	A1	10/2004	Koh et al.	2007/0257636	A1	11/2007	Phillips et al.
2004/0222751	A1	11/2004	Mollema et al.	2007/0267918	A1	11/2007	Gyland
2004/0227057	A1	11/2004	Tuominen et al.	2007/0276538	A1	11/2007	Kjellsson et al.
2004/0232845	A1	11/2004	Baarman	2008/0008273	A1	1/2008	Kim et al.
2004/0233043	A1	11/2004	Yazawa et al.	2008/0012569	A1	1/2008	Hall et al.
2004/0267501	A1	12/2004	Freed et al.	2008/0014897	A1	1/2008	Cook et al.
2005/0007067	A1	1/2005	Baarman et al.	2008/0030415	A1	2/2008	Homan et al.
2005/0021134	A1	1/2005	Opie	2008/0036588	A1	2/2008	Iverson et al.
2005/0027192	A1	2/2005	Govari et al.	2008/0047727	A1	2/2008	Sexton et al.
2005/0033382	A1	2/2005	Single	2008/0051854	A1	2/2008	Bulkes et al.
2005/0085873	A1	4/2005	Gord et al.	2008/0067874	A1	3/2008	Tseng
2005/0093475	A1	5/2005	Kuennen et al.	2008/0132909	A1	6/2008	Jacob et al.
2005/0104064	A1	5/2005	Hegarty et al.	2008/0154331	A1	6/2008	John et al.
2005/0104453	A1	5/2005	Vanderelli et al.	2008/0176521	A1	7/2008	Singh et al.
2005/0116650	A1	6/2005	Baarman	2008/0191638	A1	8/2008	Kuennen et al.
2005/0116683	A1	6/2005	Cheng et al.	2008/0197710	A1	8/2008	Kreitz et al.
2005/0122058	A1	6/2005	Baarman et al.	2008/0197802	A1	8/2008	Onishi et al.
2005/0122059	A1	6/2005	Baarman et al.	2008/0211320	A1	9/2008	Cook et al.
2005/0125093	A1	6/2005	Kikuchi et al.	2008/0211455	A1	9/2008	Park et al.
2005/0127849	A1	6/2005	Baarman et al.	2008/0238364	A1	10/2008	Weber et al.
2005/0127850	A1	6/2005	Baarman et al.	2008/0255901	A1	10/2008	Carroll et al.
2005/0127866	A1	6/2005	Hamilton et al.	2008/0265684	A1	10/2008	Farkas
2005/0135122	A1	6/2005	Cheng et al.	2008/0266748	A1	10/2008	Lee
2005/0140482	A1	6/2005	Cheng et al.	2008/0272860	A1	11/2008	Pance
2005/0151511	A1	7/2005	Chary	2008/0273242	A1	11/2008	Woodgate et al.
2005/0156560	A1	7/2005	Shimaoka et al.	2008/0278264	A1	11/2008	Karalis et al.
2005/0159913	A1	7/2005	Ariyoshi et al.	2008/0291277	A1	11/2008	Jacobsen et al.
2005/0189945	A1	9/2005	Reiderman	2008/0300657	A1	12/2008	Stultz
2005/0194926	A1	9/2005	DiStefano	2008/0300660	A1	12/2008	John
2005/0253152	A1	11/2005	Klimov et al.	2009/0010028	A1	1/2009	Baarmen et al.
2005/0288739	A1	12/2005	Hassler, Jr. et al.	2009/0015075	A1	1/2009	Cook et al.
2005/0288740	A1	12/2005	Hassler, Jr. et al.	2009/0033280	A1	2/2009	Choi et al.
2005/0288741	A1	12/2005	Hassler, Jr. et al.	2009/0033564	A1	2/2009	Cook et al.
2005/0288742	A1	12/2005	Giordano et al.	2009/0038623	A1	2/2009	Farbarik et al.
2006/0001509	A1	1/2006	Gibbs	2009/0045772	A1	2/2009	Cook et al.
2006/0010902	A1	1/2006	Trinh et al.	2009/0051224	A1	2/2009	Cook et al.
2006/0022636	A1	2/2006	Xian et al.	2009/0058189	A1	3/2009	Cook et al.
2006/0053296	A1	3/2006	Busboom et al.	2009/0058361	A1	3/2009	John
2006/0061323	A1	3/2006	Cheng et al.	2009/0067198	A1	3/2009	Graham et al.
2006/0066443	A1	3/2006	Hall	2009/0072627	A1	3/2009	Cook et al.
2006/0090956	A1	5/2006	Peshkovskiy et al.	2009/0072628	A1	3/2009	Cook et al.
2006/0132045	A1	6/2006	Baarman	2009/0072629	A1	3/2009	Cook et al.
2006/0164866	A1	7/2006	Vanderelli et al.	2009/0072782	A1	3/2009	Randall
2006/0181242	A1	8/2006	Freed et al.	2009/0079268	A1	3/2009	Cook et al.
2006/0184209	A1	8/2006	John et al.	2009/0079387	A1	3/2009	Jin et al.
2006/0184210	A1	8/2006	Singhal et al.	2009/0085408	A1	4/2009	Bruhn
2006/0185809	A1	8/2006	Elfrink et al.	2009/0085706	A1	4/2009	Baarman et al.
2006/0199620	A1	9/2006	Greene et al.	2009/0096413	A1	4/2009	Patovi et al.
2006/0202665	A1	9/2006	Hsu	2009/0102292	A1	4/2009	Cook et al.
2006/0205381	A1	9/2006	Beart et al.	2009/0108679	A1	4/2009	Porwal
2006/0214626	A1	9/2006	Nilson et al.	2009/0108997	A1	4/2009	Patterson et al.
2006/0219448	A1	10/2006	Grieve et al.	2009/0115628	A1	5/2009	Dicks et al.
				2009/0121675	A1	5/2009	Ho et al.
				2009/0127937	A1	5/2009	Widmer et al.
				2009/0134712	A1	5/2009	Cook et al.
				2009/0146892	A1	6/2009	Shimizu et al.
				2009/0153273	A1	6/2009	Chen



(56)

References Cited

U.S. PATENT DOCUMENTS

2009/0160261	A1	6/2009	Elo		2010/0123353	A1	5/2010	Joannopoulos et al.
2009/0161078	A1	6/2009	Wu et al.		2010/0123354	A1	5/2010	Joannopoulos et al.
2009/0167449	A1	7/2009	Cook et al.		2010/0123355	A1	5/2010	Joannopoulos et al.
2009/0174263	A1*	7/2009	Baarman .....	H02J 50/12 307/104	2010/0123452	A1	5/2010	Amano et al.
2009/0179502	A1	7/2009	Cook et al.		2010/0123530	A1	5/2010	Park et al.
2009/0188396	A1	7/2009	Hofmann et al.		2010/0127573	A1	5/2010	Joannopoulos et al.
2009/0189458	A1	7/2009	Kawasaki		2010/0127574	A1	5/2010	Joannopoulos et al.
2009/0195332	A1	8/2009	Joannopoulos et al.		2010/0127575	A1	5/2010	Joannopoulos et al.
2009/0195333	A1	8/2009	Joannopoulos et al.		2010/0127660	A1	5/2010	Cook et al.
2009/0212636	A1	8/2009	Cook et al.		2010/0133918	A1	6/2010	Joannopoulos et al.
2009/0213028	A1	8/2009	Cook et al.		2010/0133919	A1	6/2010	Joannopoulos et al.
2009/0218884	A1	9/2009	Soar		2010/0133920	A1	6/2010	Joannopoulos et al.
2009/0224608	A1	9/2009	Cook et al.		2010/0141042	A1	6/2010	Kesler et al.
2009/0224609	A1	9/2009	Cook et al.		2010/0148589	A1	6/2010	Hamam et al.
2009/0224723	A1	9/2009	Tanabe		2010/0148723	A1	6/2010	Cook et al.
2009/0224856	A1	9/2009	Karalis et al.		2010/0151808	A1	6/2010	Toncich et al.
2009/0230777	A1	9/2009	Baarman et al.		2010/0156346	A1	6/2010	Takada et al.
2009/0237194	A1	9/2009	Waffenschmidt et al.		2010/0156355	A1	6/2010	Bauerle et al.
2009/0243394	A1	10/2009	Levine		2010/0156570	A1	6/2010	Hong et al.
2009/0243397	A1	10/2009	Cook et al.		2010/0164295	A1	7/2010	Ichikawa et al.
2009/0251008	A1	10/2009	Sugaya		2010/0164296	A1	7/2010	Kurs
2009/0261778	A1	10/2009	Kook		2010/0164297	A1	7/2010	Kurs et al.
2009/0267558	A1	10/2009	Jung		2010/0164298	A1	7/2010	Karalis et al.
2009/0267709	A1	10/2009	Joannopoulos et al.		2010/0171368	A1	7/2010	Schatz et al.
2009/0267710	A1	10/2009	Joannopoulos et al.		2010/0171370	A1	7/2010	Karalis et al.
2009/0271047	A1	10/2009	Wakamatsu		2010/0179384	A1	7/2010	Hoeg et al.
2009/0271048	A1	10/2009	Wakamatsu		2010/0181843	A1	7/2010	Schatz et al.
2009/0273242	A1	11/2009	Cook		2010/0181844	A1	7/2010	Karalis et al.
2009/0273318	A1	11/2009	Rondoni et al.		2010/0181845	A1	7/2010	Fiorello et al.
2009/0281678	A1	11/2009	Wakamatsu		2010/0181961	A1	7/2010	Novak et al.
2009/0284082	A1	11/2009	Mohammadian		2010/0181964	A1	7/2010	Huggins et al.
2009/0284083	A1	11/2009	Karalis et al.		2010/0184371	A1	7/2010	Cook et al.
2009/0284218	A1	11/2009	Mohammadian et al.		2010/0187911	A1	7/2010	Joannopoulos et al.
2009/0284220	A1	11/2009	Toncich et al.		2010/0187913	A1	7/2010	Sample
2009/0284227	A1	11/2009	Mohammadian et al.		2010/0188183	A1	7/2010	Shpiro
2009/0284245	A1	11/2009	Kirby et al.		2010/0190435	A1	7/2010	Cook et al.
2009/0284369	A1	11/2009	Toncich et al.		2010/0190436	A1	7/2010	Cook et al.
2009/0286470	A1	11/2009	Mohammadian et al.		2010/0194206	A1	8/2010	Burdo et al.
2009/0286475	A1	11/2009	Toncich et al.		2010/0194207	A1	8/2010	Graham
2009/0286476	A1	11/2009	Toncich et al.		2010/0194334	A1	8/2010	Kirby et al.
2009/0289595	A1	11/2009	Chen et al.		2010/0194335	A1	8/2010	Kirby et al.
2009/0299918	A1	12/2009	Cook et al.		2010/0201189	A1	8/2010	Kirby et al.
2009/0302943	A1	12/2009	Chen et al.		2010/0201201	A1	8/2010	Mobarhan et al.
2009/0308933	A1	12/2009	Osada		2010/0201202	A1	8/2010	Kirby et al.
2009/0322158	A1	12/2009	Stevens et al.		2010/0201203	A1	8/2010	Schatz et al.
2009/0322280	A1	12/2009	Kamijo et al.		2010/0201204	A1	8/2010	Sakoda et al.
2010/0015918	A1	1/2010	Liu et al.		2010/0201205	A1	8/2010	Karalis et al.
2010/0017249	A1	1/2010	Fincham et al.		2010/0201310	A1	8/2010	Vorenkamp et al.
2010/0033021	A1	2/2010	Bennett		2010/0201312	A1	8/2010	Kirby et al.
2010/0034238	A1	2/2010	Bennett		2010/0201313	A1	8/2010	Vorenkamp et al.
2010/0036773	A1	2/2010	Bennett		2010/0201316	A1	8/2010	Takada et al.
2010/0038970	A1	2/2010	Cook et al.		2010/0201513	A1	8/2010	Vorenkamp et al.
2010/0045114	A1	2/2010	Sample et al.		2010/0207458	A1	8/2010	Joannopoulos et al.
2010/0052431	A1	3/2010	Mita		2010/0210233	A1	8/2010	Cook et al.
2010/0052811	A1	3/2010	Smith et al.		2010/0213770	A1	8/2010	Kikuchi
2010/0060077	A1	3/2010	Paulus et al.		2010/0213895	A1	8/2010	Keating et al.
2010/0065352	A1	3/2010	Ichikawa		2010/0217553	A1	8/2010	Von Novak et al.
2010/0066349	A1	3/2010	Lin et al.		2010/0219694	A1	9/2010	Kurs et al.
2010/0076524	A1	3/2010	Forsberg et al.		2010/0219695	A1	9/2010	Komiyama et al.
2010/0081379	A1	4/2010	Cooper et al.		2010/0219696	A1	9/2010	Kojima
2010/0094381	A1	4/2010	Kim et al.		2010/0222010	A1	9/2010	Ozaki et al.
2010/0096934	A1	4/2010	Joannopoulos et al.		2010/0225175	A1	9/2010	Karalis et al.
2010/0102639	A1	4/2010	Joannopoulos et al.		2010/0225270	A1	9/2010	Jacobs et al.
2010/0102640	A1	4/2010	Joannopoulos et al.		2010/0225271	A1	9/2010	Oyobe et al.
2010/0102641	A1	4/2010	Joannopoulos et al.		2010/0225272	A1	9/2010	Kirby et al.
2010/0104031	A1	4/2010	Lacour		2010/0231053	A1	9/2010	Karalis et al.
2010/0109443	A1	5/2010	Cook et al.		2010/0231163	A1	9/2010	Mashinsky
2010/0109445	A1	5/2010	Kurs et al.		2010/0231340	A1	9/2010	Fiorello et al.
2010/0109604	A1	5/2010	Boys et al.		2010/0234922	A1	9/2010	Forsell
2010/0115474	A1	5/2010	Takada et al.		2010/0235006	A1	9/2010	Brown
2010/0117454	A1	5/2010	Cook et al.		2010/0237706	A1	9/2010	Karalis et al.
2010/0117455	A1	5/2010	Joannopoulos et al.		2010/0237707	A1	9/2010	Karalis et al.
2010/0117456	A1	5/2010	Karalis et al.		2010/0237708	A1	9/2010	Karalis et al.
2010/0117596	A1	5/2010	Cook et al.		2010/0237709	A1	9/2010	Hall et al.
					2010/0244576	A1	9/2010	Hillan et al.
					2010/0244577	A1	9/2010	Shimokawa
					2010/0244578	A1	9/2010	Yoshikawa
					2010/0244579	A1	9/2010	Sogabe et al.
					2010/0244580	A1	9/2010	Uchida et al.



(56)

## References Cited

## U.S. PATENT DOCUMENTS

2010/0244581	A1	9/2010	Uchida	2012/0032522	A1	2/2012	Schatz et al.
2010/0244582	A1	9/2010	Yoshikawa	2012/0038525	A1	2/2012	Monsalve Carcelen et al.
2010/0244583	A1	9/2010	Shimokawa	2012/0062345	A1	3/2012	Kurs et al.
2010/0244767	A1	9/2010	Turner et al.	2012/0068549	A1	3/2012	Karalis et al.
2010/0244839	A1	9/2010	Yoshikawa	2012/0086284	A1	4/2012	Campanella et al.
2010/0248622	A1	9/2010	Kirby et al.	2012/0086867	A1	4/2012	Kesler et al.
2010/0253152	A1	10/2010	Karalis et al.	2012/0091794	A1	4/2012	Campanella et al.
2010/0253281	A1	10/2010	Li	2012/0091795	A1	4/2012	Fiorello et al.
2010/0256481	A1	10/2010	Mareci et al.	2012/0091796	A1	4/2012	Kesler et al.
2010/0256831	A1	10/2010	Abramo et al.	2012/0091797	A1	4/2012	Kesler et al.
2010/0259108	A1	10/2010	Giler et al.	2012/0091819	A1	4/2012	Kulikowski et al.
2010/0259109	A1	10/2010	Sato	2012/0091820	A1	4/2012	Campanella et al.
2010/0259110	A1	10/2010	Kurs et al.	2012/0091949	A1	4/2012	Campanella et al.
2010/0264745	A1	10/2010	Karalis et al.	2012/0091950	A1	4/2012	Campanella et al.
2010/0264746	A1	10/2010	Kazama et al.	2012/0098350	A1	4/2012	Campanella et al.
2010/0264747	A1	10/2010	Hall et al.	2012/0112531	A1	5/2012	Kesler et al.
2010/0276995	A1	11/2010	Marzetta et al.	2012/0112532	A1	5/2012	Kesler et al.
2010/0277003	A1	11/2010	Von Novak et al.	2012/0112534	A1	5/2012	Kesler et al.
2010/0277004	A1	11/2010	Suzuki et al.	2012/0112535	A1	5/2012	Karalis et al.
2010/0277005	A1	11/2010	Karalis et al.	2012/0112536	A1	5/2012	Karalis et al.
2010/0277120	A1	11/2010	Cook et al.	2012/0112538	A1	5/2012	Kesler et al.
2010/0277121	A1	11/2010	Hall et al.	2012/0112691	A1	5/2012	Kurs et al.
2010/0289341	A1	11/2010	Ozaki et al.	2012/0119569	A1	5/2012	Karalis et al.
2010/0289449	A1	11/2010	Elo	2012/0119575	A1	5/2012	Kurs et al.
2010/0295505	A1	11/2010	Jung et al.	2012/0119576	A1	5/2012	Kesler et al.
2010/0295506	A1	11/2010	Ichikawa	2012/0119698	A1	5/2012	Karalis et al.
2010/0308939	A1	12/2010	Kurs	2012/0139355	A1	6/2012	Ganem et al.
2010/0314946	A1	12/2010	Budde et al.	2012/0146575	A1	6/2012	Armstrong et al.
2010/0327660	A1	12/2010	Karalis et al.	2012/0153732	A1	6/2012	Kurs et al.
2010/0327661	A1	12/2010	Karalis et al.	2012/0153733	A1	6/2012	Schatz et al.
2010/0328044	A1	12/2010	Waffenschmidt et al.	2012/0153734	A1	6/2012	Kurs et al.
2011/0004269	A1	1/2011	Strother et al.	2012/0153735	A1	6/2012	Karalis et al.
2011/0012431	A1	1/2011	Karalis et al.	2012/0153736	A1	6/2012	Karalis et al.
2011/0018361	A1	1/2011	Karalis et al.	2012/0153737	A1	6/2012	Karalis et al.
2011/0025131	A1	2/2011	Karalis et al.	2012/0153738	A1	6/2012	Karalis et al.
2011/0031928	A1	2/2011	Soar	2012/0153893	A1	6/2012	Schatz et al.
2011/0043046	A1	2/2011	Joannopoulos et al.	2012/0184338	A1	7/2012	Kesler et al.
2011/0043047	A1	2/2011	Karalis et al.	2012/0206096	A1	8/2012	John
2011/0043048	A1	2/2011	Karalis et al.	2012/0223573	A1	9/2012	Schatz et al.
2011/0043049	A1	2/2011	Karalis et al.	2012/0228952	A1	9/2012	Hall et al.
2011/0049995	A1	3/2011	Hashiguchi	2012/0228953	A1	9/2012	Kesler et al.
2011/0049996	A1	3/2011	Karalis et al.	2012/0228954	A1	9/2012	Kesler et al.
2011/0049998	A1	3/2011	Karalis et al.	2012/0235500	A1	9/2012	Ganem et al.
2011/0074218	A1	3/2011	Karalis et al.	2012/0235501	A1	9/2012	Kesler et al.
2011/0074346	A1	3/2011	Hall et al.	2012/0235502	A1	9/2012	Kesler et al.
2011/0074347	A1	3/2011	Karalis et al.	2012/0235503	A1	9/2012	Kesler et al.
2011/0089895	A1	4/2011	Karalis et al.	2012/0235504	A1	9/2012	Kesler et al.
2011/0095618	A1	4/2011	Schatz et al.	2012/0235505	A1	9/2012	Schatz et al.
2011/0115303	A1	5/2011	Baarman et al.	2012/0235506	A1	9/2012	Karalis et al.
2011/0115431	A1	5/2011	Dunworth et al.	2012/0235567	A1	9/2012	Karalis et al.
2011/0121920	A1	5/2011	Kurs et al.	2012/0235633	A1	9/2012	Kesler et al.
2011/0128015	A1	6/2011	Dorairaj et al.	2012/0235634	A1	9/2012	Hall et al.
2011/0140544	A1	6/2011	Karalis et al.	2012/0239117	A1	9/2012	Kesler et al.
2011/0148219	A1	6/2011	Karalis et al.	2012/0242159	A1	9/2012	Lou et al.
2011/0162895	A1	7/2011	Karalis et al.	2012/0242225	A1	9/2012	Karalis et al.
2011/0169339	A1	7/2011	Karalis et al.	2012/0248884	A1	10/2012	Karalis et al.
2011/0181122	A1	7/2011	Karalis et al.	2012/0248886	A1	10/2012	Kesler et al.
2011/0193416	A1	8/2011	Campanella et al.	2012/0248887	A1	10/2012	Kesler et al.
2011/0193419	A1	8/2011	Karalis et al.	2012/0248888	A1	10/2012	Kesler et al.
2011/0198939	A1	8/2011	Karalis et al.	2012/0248981	A1	10/2012	Karalis et al.
2011/0215086	A1	9/2011	Yeh	2012/0256494	A1	10/2012	Kesler et al.
2011/0221278	A1	9/2011	Karalis et al.	2012/0267960	A1	10/2012	Low et al.
2011/0227528	A1	9/2011	Karalis et al.	2012/0280765	A1	11/2012	Kurs et al.
2011/0227530	A1	9/2011	Karalis et al.	2012/0313449	A1	12/2012	Kurs et al.
2011/0241618	A1	10/2011	Karalis et al.	2012/0313742	A1	12/2012	Kurs et al.
2011/0248573	A1	10/2011	Kanno et al.	2013/0007949	A1	1/2013	Kurs et al.
2011/0254377	A1	10/2011	Wildmer et al.	2013/0020878	A1	1/2013	Karalis et al.
2011/0254503	A1	10/2011	Widmer et al.	2013/0033118	A1	2/2013	Karalis et al.
2011/0266878	A9	11/2011	Cook et al.	2013/0038402	A1	2/2013	Karalis et al.
2011/0278943	A1	11/2011	Eckhoff et al.	2013/0057364	A1	3/2013	Kesler et al.
2012/0001492	A9	1/2012	Cook et al.	2013/0062966	A1	3/2013	Verghese et al.
2012/0001593	A1	1/2012	DiGuardo	2013/0069441	A1	3/2013	Verghese et al.
2012/0007435	A1	1/2012	Sada et al.	2013/0069753	A1	3/2013	Kurs et al.
2012/0007441	A1	1/2012	John et al.	2013/0099587	A1	4/2013	Lou et al.
2012/0025602	A1	2/2012	Boys et al.	2013/0154383	A1	6/2013	Kasturi et al.
				2013/0154389	A1	6/2013	Kurs et al.
				2013/0159956	A1	6/2013	Verghese et al.
				2013/0175874	A1	7/2013	Lou et al.
				2013/0175875	A1	7/2013	Kurs et al.



(56)

## References Cited

## U.S. PATENT DOCUMENTS

2013/0200716 A1 8/2013 Kesler et al.  
 2013/0200721 A1 8/2013 Kurs et al.  
 2013/0221744 A1 8/2013 Hall et al.  
 2013/0241302 A1 9/2013 Miyamoto et al.  
 2013/0278073 A1 10/2013 Kurs et al.  
 2013/0278074 A1 10/2013 Kurs et al.  
 2013/0278075 A1 10/2013 Kurs et al.  
 2013/0300353 A1 11/2013 Kurs et al.  
 2013/0307349 A1 11/2013 Hall et al.  
 2013/0320773 A1 12/2013 Schatz et al.  
 2013/0334892 A1 12/2013 Hall et al.  
 2014/0002012 A1 1/2014 McCauley et al.  
 2014/0070764 A1 3/2014 Keeling  
 2014/0074185 A1 3/2014 Fell et al.

## FOREIGN PATENT DOCUMENTS

CN 102439669 5/2012  
 CN 103329397 9/2013  
 DE 38 24 972 1/1989  
 DE 100 29147 12/2001  
 DE 200 16 655 3/2002  
 DE 102 21 484 11/2003  
 DE 103 04 584 8/2004  
 DE 10 2005 036290 2/2007  
 DE 10 2006 044057 4/2008  
 EP 1 335 477 8/2003  
 EP 1 521 206 4/2005  
 EP 1 524 010 4/2005  
 EP 2 357 716 8/2011  
 JP 02-097005 4/1990  
 JP 4-265875 9/1992  
 JP 6-341410 12/1994  
 JP 9-182323 7/1997  
 JP 9-298847 11/1997  
 JP 10-164837 6/1998  
 JP 11-75329 3/1999  
 JP 11-188113 7/1999  
 JP 2001-309580 11/2001  
 JP 2002-010535 1/2002  
 JP 2003-179526 6/2003  
 JP 2004-166459 6/2004  
 JP 2004-201458 7/2004  
 JP 2004-229144 8/2004  
 JP 2005-57444 3/2005  
 JP 2005-149238 6/2005  
 JP 2006-074848 3/2006  
 JP 2007-505480 3/2007  
 JP 2007-266892 10/2007  
 JP 2007-537637 12/2007  
 JP 2008-508842 3/2008  
 JP 2008-206231 9/2008  
 JP 2008-206327 9/2008  
 JP 2009-038924 2/2009  
 JP 2011-072074 4/2011  
 JP 2012-504387 2/2012  
 JP 2013-543718 12/2013  
 KR 10-2007-0017804 2/2007  
 KR 10-2008-0007635 1/2008  
 KR 10-2009-0122072 11/2009  
 KR 10-2011-0050920 5/2011  
 SG 112842 7/2005  
 WO WO 92/17929 10/1992  
 WO WO 93/23908 11/1993  
 WO WO 94/28560 12/1994  
 WO WO 95/11545 4/1995  
 WO WO 96/02970 2/1996  
 WO WO 98/50993 11/1998  
 WO WO 00/77910 12/2000  
 WO WO 03/092329 11/2003  
 WO WO 03/096361 11/2003  
 WO WO 03/096512 11/2003  
 WO WO 2004/015885 2/2004  
 WO WO 2004/038888 5/2004  
 WO WO 2004/055654 7/2004

WO WO 2004/073150 8/2004  
 WO WO 2004/073166 8/2004  
 WO WO 2004/073176 8/2004  
 WO WO 2004/073177 8/2004  
 WO WO 2004/112216 12/2004  
 WO WO 2005/024865 3/2005  
 WO WO 2005/060068 6/2005  
 WO WO 2005/109597 11/2005  
 WO WO 2005/109598 11/2005  
 WO WO 2006/011769 2/2006  
 WO WO 2007/008646 1/2007  
 WO WO 2007/020583 2/2007  
 WO WO 2007/042952 4/2007  
 WO WO 2007/084716 7/2007  
 WO WO 2007/084717 7/2007  
 WO WO 2008/109489 9/2008  
 WO WO 2008/118178 10/2008  
 WO WO 2009/009559 1/2009  
 WO WO 2009/018568 2/2009  
 WO WO 2009/023155 2/2009  
 WO WO 2009/023646 2/2009  
 WO WO 2009/033043 3/2009  
 WO WO 2009/062438 5/2009  
 WO WO 2009/070730 6/2009  
 WO WO 2009/126963 10/2009  
 WO WO 2009/140506 11/2009  
 WO WO 2009/149464 12/2009  
 WO WO 2009/155000 12/2009  
 WO WO 2010/014634 2/2010  
 WO WO 2010/030977 3/2010  
 WO WO 2010/036980 4/2010  
 WO WO 2010/039967 4/2010  
 WO WO 2010/090538 8/2010  
 WO WO 2010/090539 8/2010  
 WO WO 2010/093997 8/2010  
 WO WO 2010/104569 9/2010  
 WO WO 2011/061388 5/2011  
 WO WO 2011/061821 5/2011  
 WO WO 2011/062827 5/2011  
 WO WO 2011/112795 9/2011  
 WO WO 2012/037279 3/2012  
 WO WO 2012/170278 12/2012  
 WO WO 2013/013235 1/2013  
 WO WO 2013/020138 2/2013  
 WO WO 2013/036947 3/2013  
 WO WO 2013/059441 4/2013  
 WO WO 2013/067484 5/2013  
 WO WO 2013/113017 8/2013  
 WO WO 2013/142840 9/2013  
 WO WO 2014/004843 1/2014

## OTHER PUBLICATIONS

“Physics Update, Unwired Energy”, *Physics Today*, pp. 26, (Jan. 2007) (See <http://arxiv.org/abs/physics/0611063>).

“In pictures: A year in technology”, *BBC News*, (Dec. 28, 2007).

“Next Little Thing 2010 Electricity without wires”, CNN Money (See [money.cnn.com/galleries/2009/smallbusiness/0911/gallery.next\\_little\\_thing\\_2010.smb/](http://money.cnn.com/galleries/2009/smallbusiness/0911/gallery.next_little_thing_2010.smb/)) (dated Nov. 30, 2009).

Abe et al. “A Noncontact Charger Using a Resonant Converter with Parallel Capacitor of the Secondary Coil”. *IEEE*, 36(2):444-451, Mar./Apr. 2000.

Ahmadian, M. et al., “Miniature Transmitter for Implantable Micro Systems”, *Proceedings of the 25th Annual International Conference of the IEEE EMBS Cancun, Mexico*, pp. 3028-3031 (Sep. 17-21, 2003).

Aoki, T. et al., “Observation of strong coupling between one atom and a monolithic microresonator”, *Nature*, vol. 443:671-674 (2006).

Apneseth et al. “Introducing wireless proximity switches” *ABB Review* Apr. 2002.

Aristeidis Karalis et al., “Efficient Wireless Physics, vol. 323, pp. 34-48 (2008) non-radiative mid-range energy transfer”, *Annals of Physics*, vol. 323, pp. 34-48 (2008).

Baker et al., “Feedback Analysis and Design of RF Power Links for Low-Power Bionic Systems,” *IEEE Transactions on Biomedical Circuits and Systems*, vol. 1(1):28-38 (Mar. 2007).



(56)

## References Cited

## OTHER PUBLICATIONS

- Balanis, C.A., "Antenna Theory: Analysis and Design," 3rd Edition, Sections 4.2, 4.3, 5.2, 5.3 (Wiley, New Jersey, 2005).
- Berardelli, P., "Outlets Are Out", ScienceNOW Daily News, Science Now, <http://sciencenow.sciencemag.org/cgi/content/full/2006/1114/2>, (Nov. 14, 2006) 2 pages.
- Biever, C., "Evanescence coupling' could power gadgets wirelessly", NewScientistsTech.com, <http://www.newscientisttech.com/article.ns?id=dn10575&print=true>, (Nov. 15, 2006) 2 pages.
- Borenstein, S., "Man tries wirelessly boosting batteries", (The Associated Press), USA Today, (Nov. 16, 2006) 1 page.
- Borenstein, S., "Man tries wirelessly boosting batteries", AP Science Writer, Boston.com, (See [http://www.boston.com/business/technology/articles/2006/11/15/man\\_tries\\_wirelessly\\_b...](http://www.boston.com/business/technology/articles/2006/11/15/man_tries_wirelessly_b...)) (Nov. 15, 2006).
- Boyle, A., "Electro-nirvana? Not so fast", MSNBC, [http://cosmiclog.msnbc.msn.com/\\_news/2007/06/08/4350760-electro-nirvana-not-so-fast](http://cosmiclog.msnbc.msn.com/_news/2007/06/08/4350760-electro-nirvana-not-so-fast), (Jun. 8, 2007) 1 page.
- Budhia, M. et al., "A New IPT Magnetic Coupler for Electric Vehicle Charging Systems", IECON 2010—36th Annual Conference on IEEE Industrial Electronics Society, Glendale, AZ, pp. 2487-2492 (Nov. 7-10, 2010).
- Budhia, M. et al., "Development and evaluation of single sided flux couplers for contactless electric vehicle charging", 2011 IEEE Energy Conversion Congress and Exposition (ECCE), Phoenix, AZ, pp. 614-621 (Sep. 17-22, 2011).
- Budhia, M. et al., "Development of a Single-Sided Flux Magnetic Coupler for Electric Vehicle IPT", *IEEE Transactions on Industrial Electronics*, vol. 60:318-328 (Jan. 2013).
- Bulkeley, W. M., "MIT Scientists Pave the Way for Wireless Battery Charging", The Wall Street Journal (See [http://online.wsj.com/article/SB118123955549228045.html?mod=googlenews\\_wsj](http://online.wsj.com/article/SB118123955549228045.html?mod=googlenews_wsj)), (Jun. 8, 2007) 2 pages.
- Burn et al., "Invention Description", (Feb. 5, 2008).
- Cass, S., "Air Power—Wireless data connections are common—now scientists are working on wireless power", Sponsored by IEEE Spectrum, <http://spectrum.ieee.org/computing/hardware/air-power>, (Nov. 2006) 2 pages.
- Castelvecchi, Davide, "The Power of Induction—Cutting the last cord could resonate with our increasingly gadget dependent lives", Science News Online, vol. 172, No. 3, Jul. 21, 2007, 6 pages.
- Chang, A., "Recharging the Wireless Way—Even physicists forget to recharge their cell phones sometimes.", PC Magazine, ABC News Internet Ventures, (Dec. 12, 2006) 1 page.
- Chinaview, "Scientists light bulb with 'wireless electricity'", www.Chinaview.cn, [http://news.xinhuanet.com/english/2007-06/08/content\\_6215681.htm](http://news.xinhuanet.com/english/2007-06/08/content_6215681.htm), Jun. 2007, 1 page.
- Cooks, G., "The vision of an MIT physicist: Getting rid of pesky rechargers", Boston.com, (Dec. 11, 2006) 1 page.
- Derbyshire, D., "The end of the plug? Scientists invent wireless device that beams electricity through your home", Daily Mail, [http://www.dailymail.co.uk/pages/live/articles/technology/technology.html?in\\_article\\_id=4...](http://www.dailymail.co.uk/pages/live/articles/technology/technology.html?in_article_id=4...), (Jun. 7, 2007) 3 pages.
- Eisenberg, Anne, "Automatic Recharging, From a Distance", The New York Times, (see [www.nytimes.com/2012/03/11/business/built-in-wireless-charging-for-electronic-devices.html?\\_r=0](http://www.nytimes.com/2012/03/11/business/built-in-wireless-charging-for-electronic-devices.html?_r=0)) (published on Mar. 10, 2012).
- Esser et al., "A New Approach to Power Supplies for Robots", IEEE, vol. 27(5):872-875, (Sep./Oct. 1991).
- Fan, Shanhui et al., "Rate-Equation Analysis of Output Efficiency and Modulation Rate of Photonic-Crystal Light-Emitting Diodes", IEEE Journal Quantum Electronics, vol. 36(10):1123-1130 (Oct. 2000).
- Fenske et al., "Dielectric Materials at Microwave Frequencies", Applied Microwave & Wireless, pp. 92-100 (2000).
- Fernandez, C. et al., "A simple dc-dc converter for the power supply of a cochlear implant", IEEE, pp. 1965-1970 (2003).
- Ferris, David, "How Wireless Charging Will Make Life Simpler (and Greener)", Forbes (See [forbes.com/sites/davidferris/2012/07/24/how-wireless-charging-will-make-life-simpler-and-greener/print/](http://forbes.com/sites/davidferris/2012/07/24/how-wireless-charging-will-make-life-simpler-and-greener/print/)) (dated Jul. 24, 2012).
- Fildes, J., "Physics Promises Wireless Power", (Science and Technology Reporter), BBC News, (Nov. 15, 2006) 3 pages.
- Fildes, J., "The technology with impact 2007", BBC News, (Dec. 27, 2007) 3 pages.
- Fildes, J., "Wireless energy promise powers up", BBC News, <http://news.bbc.co.uk/2/hi/technology/6725955.stm>, (Jun. 7, 2007) 3 pages.
- Finkenzeller, Klaus, "RFID Handbook—Fundamentals and Applications in Contactless Smart Cards", Nikhan Kohgyo-sya, Kanno Taihei, first version, pp. 32-37, 253 (Aug. 21, 2001).
- Finkenzeller, Klaus, "RFID Handbook (2nd Edition)", The Nikkan Kogyo Shimbun, Ltd., pp. 19, 20, 38, 39, 43, 44, 62, 63, 67, 68, 87, 88, 291, 292 (Published on May 31, 2004).
- Freedman, D.H., "Power on a Chip", MIT Technology Review, (Nov. 2004).
- Gary Peterson, "MIT WiTricity Not So Original After All", *Feed Line No. 9*, (See <http://www.tfcbooks.com/articles/witricity.htm>) printed Nov. 12, 2009.
- Geyi, Wen, "A Method for the Evaluation of Small Antenna Q", IEEE Transactions on Antennas and Propagation, vol. 51(8):2124-2129 (Aug. 2003).
- Hadley, F., "Goodbye Wires—MIT Team Experimentally Demonstrates Wireless Power Transfer, Potentially Useful for Power Laptops, Cell-Phones Without Cords", Massachusetts Institute of Technology, Institute for Soldier D Nanotechnologies, <http://web.mit.edu/newsoffice/2007/wireless-0607.html>, (Jun. 7, 2007) 3 pages.
- Haus, H.A., "Waves and Fields in Optoelectronics," Chapter 7 "Coupling of Modes—Resonators and Couplers" (Prentice-Hall, New Jersey, 1984).
- Heikkinen et al., "Performance and Efficiency of Planar Rectennas for Short-Range Wireless Power Transfer at 2.45 GHz", Microwave and Optical technology Letters, vol. 31(2):86-91, (Oct. 20, 2001).
- Highfield, R., "Wireless revolution could spell end of plugs", (Science Editor), Telegraph.co.uk, <http://www.telegraph.co.uk/news/main.jhtml?xml=/news/2007/06/07/nwireless107.xml>, (Jun. 7, 2007) 3 pages.
- Hirai et al., "Integral Motor with Driver and Wireless Transmission of Power and Information for Autonomous Subspindle Drive", IEEE, vol. 15(1):13-20, (Jan. 2000).
- Hirai et al., "Practical Study on Wireless Transmission of Power and Information for Autonomous Decentralized Manufacturing System", IEEE, vol. 46(2):349-359, Apr. 1999.
- Hirai et al., "Study on Intelligent Battery Charging Using Inductive Transmission of Power and Information", IEEE, vol. 15(2):335-345, (Mar. 2000).
- Hirai et al., "Wireless Transmission of Power and Information and Information for Cableless Linear Motor Drive", IEEE, vol. 15(1):21-27, (Jan. 2000).
- Hirayama, M., "Splashpower—World Leaders in Wireless Power", Powerpoint presentation, Splashpower Japan, (Sep. 3, 2007) 30 pages.
- Ho, S. L. et al., "A Comparative Study Between Novel Witricity and Traditional Inductive Magnetic Coupling in Wireless Charging", IEEE Transactions on Magnetics, vol. 47(5):1522-1525 (May 2011).
- Infotech Online, "Recharging gadgets without cables", infotech.indiatimes.com, (Nov. 17, 2006) 1 page.
- Jackson, J. D., "Classical Electrodynamics", 3rd Edition, Wiley, New York, 1999, pp. 201-203.
- Jackson, J.D., "Classical Electrodynamics," 3rd Edition, Sections 1.11, 5.5, 5.17, 6.9, 8.1, 8.8, 9.2, 9.3 (Wiley, New York, 1999).
- Jacob, M. V. et al., "Lithium Tantalate—A High Permittivity Dielectric Material for Microwave Communication Systems", *Proceedings of IEEE TENCON—Poster Papers*, pp. 1362-1366, 2003.
- Karalis, Aristeidis, "Electricity Unplugged", Feature: Wireless Energy Physics World, physicsworld.com, pp. 23-25 (Feb. 2009).
- Kawamura et al., "Wireless Transmission of Power and Information Through One High-Frequency Resonant AC Link Inverter for Robot Manipulator Applications", IEEE, vol. 32(3):503-508, (May/Jun. 1996).



(56)

## References Cited

## OTHER PUBLICATIONS

- Kurs, A. et al., "Wireless Power Transfer via Strongly Coupled Magnetic Resonances", *Science* vol. 317, pp. 83-86 (Jul. 6, 2007).
- Kurs, A. et al., "Simultaneous mid-range power transfer to multiple devices", *Applied Physics Letters*, vol. 96, No. 044102 (2010).
- Kurs, A. et al., "Optimized design of a low-resistance electrical conductor for the multimegahertz range", *Applied Physics Letters*, vol. 98:172504-172504-3 (Apr. 2011).
- Lamb, Gregory M., "Look Ma—no wires!—Electricity broadcast through the air may someday run your home", *The Christian Science Monitor*, <http://www.csmonitor.com/2006/1116/p14s01-stct.html>, Nov. 15, 2006, 2 pages.
- Lee, "Antenna Circuit Design for RFID Applications," Microchip Technology Inc., AN710, 50 pages (2003).
- Lee, "RFID Coil Design," Microchip Technology Inc., AN678, 21 pages (1998).
- Liang et al., "Silicon waveguide two-photon absorption detector at 1.5  $\mu\text{m}$  wavelength for autocorrelation measurements," *Applied Physics Letters*, 81(7):1323-1325 (Aug. 12, 2002).
- Markoff, J., "Intel Moves to Free Gadgets of Their Recharging Cords", *The New York Times*—[nytimes.com](http://www.nytimes.com), Aug. 21, 2008, 2 pages.
- Mediano, A. et al. "Design of class E amplifier with nonlinear and linear shunt capacitances for any duty cycle", *IEEE Trans. Microwave Theor. Tech.*, vol. 55, No. 3, pp. 484-492, (2007).
- Microchip Technology Inc., "microID 13.56 MHz Design Guide—MCRF355/360 Reader Reference Design," 24 pages (2001).
- Minkel, J. R., "Wireless Energy Lights Bulb from Seven Feet Away—Physicists vow to cut the cord between your laptop battery and the wall socket—with just a simple loop of wire", *Scientific American*, <http://www.scientificamerican.com/article.cfm?id=wireless-energy-lights-bulb-from-seven-feet-away>, Jun. 7, 2007, 1 page.
- Minkel, J. R., "Wireless Energy Transfer May Power Devices at a Distance", *Scientific American*, Nov. 14, 2006, 1 page.
- Morgan, J., "Lab report: Pull the plug for a positive charge", *The Herald*, Web Issue 2680, (Nov. 16, 2006) 3 pages.
- Moskvitch, Katia, "Wireless charging—the future for electric cars?", *BBC News Technology* (See [www.bbc.co.uk/news/technology-14183409](http://www.bbc.co.uk/news/technology-14183409)) (dated Jul. 21, 2011).
- O'Brien et al., "Analysis of Wireless Power Supplies for Industrial Automation Systems", *IEEE*, pp. 367-72 (Nov. 2-6, 2003).
- O'Brien et al., "Design of Large Air-Gap Transformers for Wireless Power Supplies", *IEEE*, pp. 1557-1562 (Jun. 15-19, 2003).
- Pendry, J. B., "A Chiral Route to Negative Refraction", *Science*, vol. 306:1353-1355 (2004).
- Physics Today*, "Unwired energy questions asked answered", Sep. 2007, pp. 16-17.
- Powercast LLC. "White Paper" Powercast simply wire free, 2003.
- PR News Wire, "The Big Story for CES 2007: The public debut of eCoupled Intelligent Wireless Power", Press Release, Fulton Innovation LLC, Las Vegas, NV, (Dec. 27, 2006) 3 pages.
- Press Release, "The world's first sheet-type wireless power transmission system: Will a socket be replaced by e-wall?", Public Relations Office, School of Engineering, University of Tokyo, Japan, Dec. 12, 2006, 4 pages.
- PRESSTV, "Wireless power transfer possible", <http://edition.presstv.ir/detail/12754.html>, Jun. 11, 2007, 1 page.
- Reidy, C. (Globe Staff), "MIT discovery could unplug your iPod forever", *Boston.com*, [http://www.boston.com/business/ficker/2007/06/mit\\_discovery\\_c.html](http://www.boston.com/business/ficker/2007/06/mit_discovery_c.html), (Jun. 7, 2007) 3 pages.
- Risen, C., "Wireless Energy", *The New York Times*, (Dec. 9, 2007) 1 page.
- Sakamoto et al., "A Novel Circuit for Non-Contact Charging Through Electro-Magnetic Coupling", *IEEE*, pp. 168-174 (1992).
- Scheible, G. et al., "Novel Wireless Power Supply System for Wireless Communication Devices in Industrial Automation Systems", *IEEE*, pp. 1358-1363, (Nov. 5-8, 2002).
- Schneider, D. "A Critical Look at Wireless Power", *IEEE Spectrum*, pp. 35-39 (May 2010).
- Schneider, David, "Electrons Unplugged. Wireless power at a distance is still far away", *IEEE Spectrum*, pp. 35-39 (May 2010).
- Schuder, J. C. et al., "An Inductively Coupled RF System for the Transmission of 1 kW of Power Through the Skin", *IEEE Transactions on Bio-Medical Engineering*, vol. BME-18, No. 4, pp. 265-273 (Jul. 1971).
- Schuder, J. C., "Powering an Artificial Heart: Birth of the Inductively Coupled-Radio Frequency System in 1960", *Artificial Organs*, vol. 26:909-915 (2002).
- Schuder, J.C. et al., "Energy Transport Into the Closed Chest From a Set of Very-Large Mutually Orthogonal Coils", *Communication Electronics*, vol. 64:527-534 (Jan. 1963).
- Schutz, J. et al., "Load Adaptive Medium Frequency Resonant Power Supply", *IEEE*, pp. 282-287 (Nov. 2002).
- Sekitani et al. "A large-area wireless power-transmission sheet using printed organic transistors and plastic MEMS switches" [www.nature.com/naturematerials](http://www.nature.com/naturematerials). Published online Apr. 29, 2007.
- Sekitani et al., "A large-area flexible wireless power transmission sheet using printed plastic MEMS switches and organic field-effect transistors", *IEDM '06, International Electron Devices Meeting*, (Dec. 11-13, 2006) 4 pages.
- Sekiya, H. et al., "FM/PWM control scheme in class DE inverter", *IEEE Trans. Circuits Syst. I*, vol. 51(7) (Jul. 2004).
- Senge, M., "MIT's wireless electricity for mobile phones", *Vanguard*, <http://www.vanguardngr.com/articles/2002/features/gsm/gsm211062007.htm>, (Jun. 11, 2007) 1 page.
- Sensiper, S., "Electromagnetic wave propagation on helical conductors", Technical Report No. 194 (based on PhD Thesis), Massachusetts Institute of Technology, (May 16, 1951) 126 pages.
- Soljagic, M., "Wireless Non-Radiative Energy Transfer—PowerPoint presentation". Massachusetts Institute of Technology, (Oct. 6, 2005).
- Soljagic, M. et al., "Wireless Energy Transfer Can Potentially Recharge Laptops Cell Phones without Cords", (Nov. 14, 2006) 3 pages.
- Soljagic, M. et al., "Photonic-crystal slow-light enhancement of nonlinear phase sensitivity", *J. Opt. Soc. Am B*, vol. 19, No. 9, pp. 2052-2059 (Sep. 2002).
- Soljagic, M., "Wireless nonradiative energy transfer", *Visions of Discovery New Light on Physics, Cosmology, and Consciousness*, Cambridge University Press, New York, NY pp. 530-542 (2011).
- Someya, Takao. "The world's first sheet-type wireless power transmission system". University of Tokyo, (Dec. 12, 2006).
- Staelin, David H. et al., *Electromagnetic Waves*, Chapters 2, 3, 4, and 8, pp. 46-176 and 336-405 (Prentice Hall Upper Saddle River, New Jersey 1998).
- Stark III, Joseph C., "Wireless Power Transmission Utilizing a Phased Array of Tesla Coils", Master Thesis, Massachusetts Institute of Technology (2004).
- Stewart, W., "The Power to Set you Free", *Science*, vol. 317:55-56 (Jul. 6, 2007).
- Tang, S.C. et al., "Evaluation of the Shielding Effects on Printed-Circuit-Board Transformers Using Ferrite Plates and Copper Sheets", *IEEE Transactions on Power Electronics*, vol. 17:1080-1088 (Nov. 2002).
- Tesla, Nikola, "High Frequency Oscillators for Electro-Therapeutic and Other Purposes", *Proceedings of the IEEE*, vol. 87:1282-1292 (Jul. 1999).
- Tesla, Nikola, "High Frequency Oscillators for Electro-Therapeutic and Other Purposes", *The Electrical Engineer*, vol. XXVI, No. 50 (Nov. 17, 1898).
- Texas Instruments, "HF Antenna Design Notes—Technical Application Report," Literature No. 11-08-26-003, 47 pages (Sep. 2003).
- Thomsen et al., "Ultrahigh speed all-optical demultiplexing based on two-photon absorption in a laser diode," *Electronics Letters*, 34(19):1871-1872 (Sep. 17, 1998).
- UPM Rafsec, "Tutorial overview of inductively coupled RFID Systems," 7 pages (May 2003).
- Valtchev et al. "Efficient Resonant Inductive Coupling Energy Transfer Using New Magnetic and Design Criteria". *IEEE*, pp. 1293-1298, 2005.



(56)

**References Cited**

## OTHER PUBLICATIONS

- Vandevoorde et al., "Wireless energy transfer for stand-alone systems: a comparison between low and high power applicability", *Sensors and Actuators*, vol. 92:305-311 (2001).
- Vilkomerson, David et al., "Implantable Doppler System for Self-Monitoring Vascular Grafts", *IEEE Ultrasonics Symposium*, pp. 461-465 (2004).
- Villeneuve, Pierre R. et al., "Microcavities in photonic crystals: Mode symmetry, tunability, and coupling efficiency", *Physical Review B*, vol. 54:7837-7842 (Sep. 15, 1996).
- Yariv, Amnon et al., "Coupled-resonator optical waveguide: a proposal and analysis", *Optics Letters*, vol. 24(11):711-713 (Jun. 1, 1999).
- Yates, David C. et al., "Optimal Transmission Frequency for Ultralow-Power Short-Range Radio Links", *IEEE Transactions on Circuits and Systems—1 Regular Papers*, vol. 51:1405-1413 (Jul. 2004).
- Yoshihiro Konishi, *Microwave Electronic Circuit Technology*, Chapter 4, pp. 145-197 (Marcel Dekker, Inc., New York, NY 1998).
- Ziaie, Babak et al., "A Low-Power Miniature Transmitter Using a Low-Loss Silicon Platform for Biotelemetry", *Proceedings—19th International Conference IEEE/EMBS*, pp. 2221-2224, (Oct. 30, Nov. 2, 1997) 4 pages.
- Zierhofer, Clemens M. et al., "High-Efficiency Coupling-Insensitive Transcutaneous Power and Data Transmission Via an Inductive Link", *IEEE Transactions on Biomedical Engineering*, vol. 37, No. 7, pp. 716-722 (Jul. 1990).
- PCT/US2012/054490, International Search Report and Written Opinion for PCT/US2012/054490, dated Feb. 28, 2013, 8 pages.
- PCT/US2011/054544, International Search Report and Written Opinion for PCT/US2011/054544, dated Jan. 30, 2012, 17 pages.
- European Search Report for European Application No. EP 17 16 3659 dated Oct. 26, 2017.

\* cited by examiner



Fig. 1

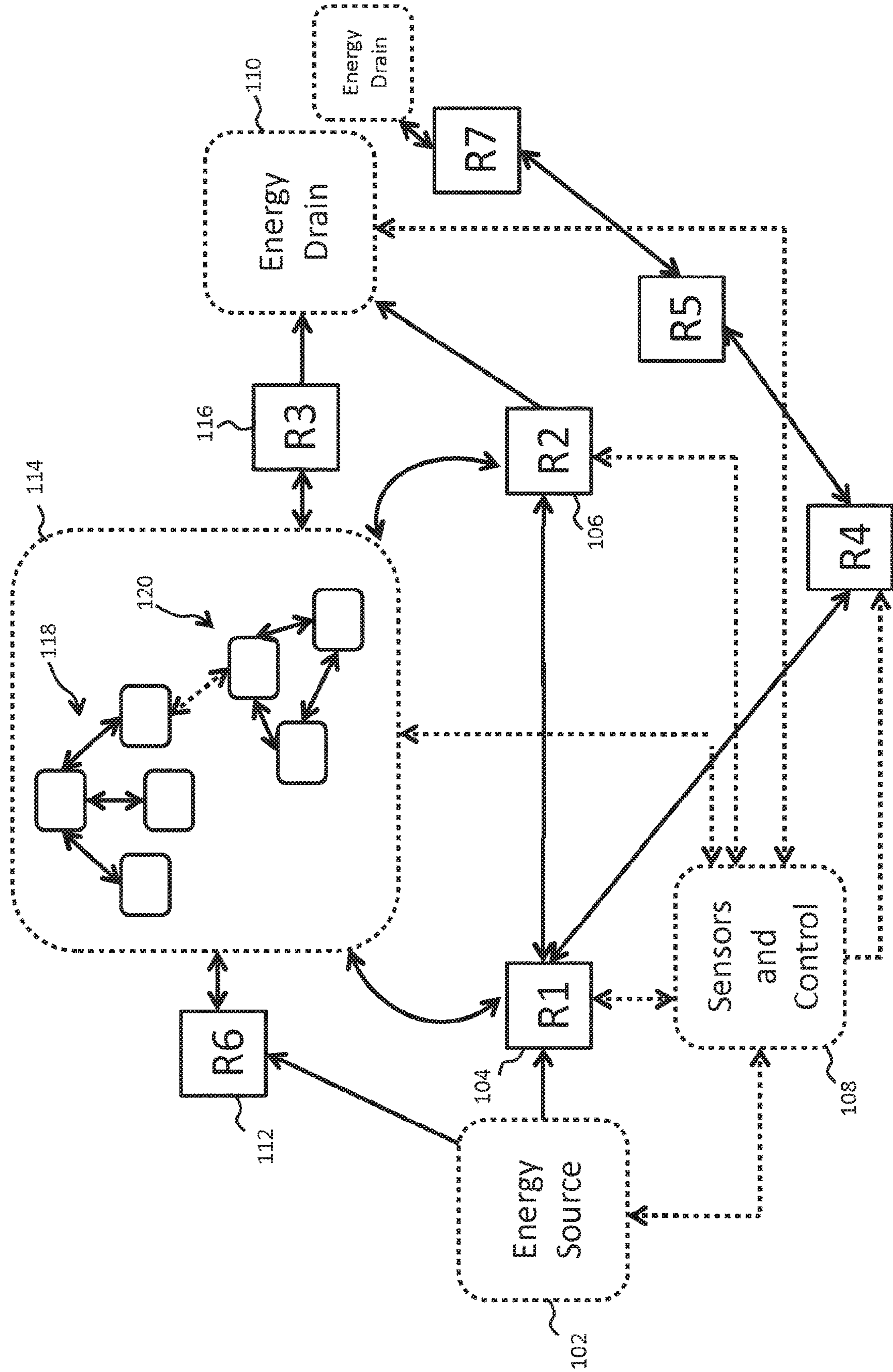



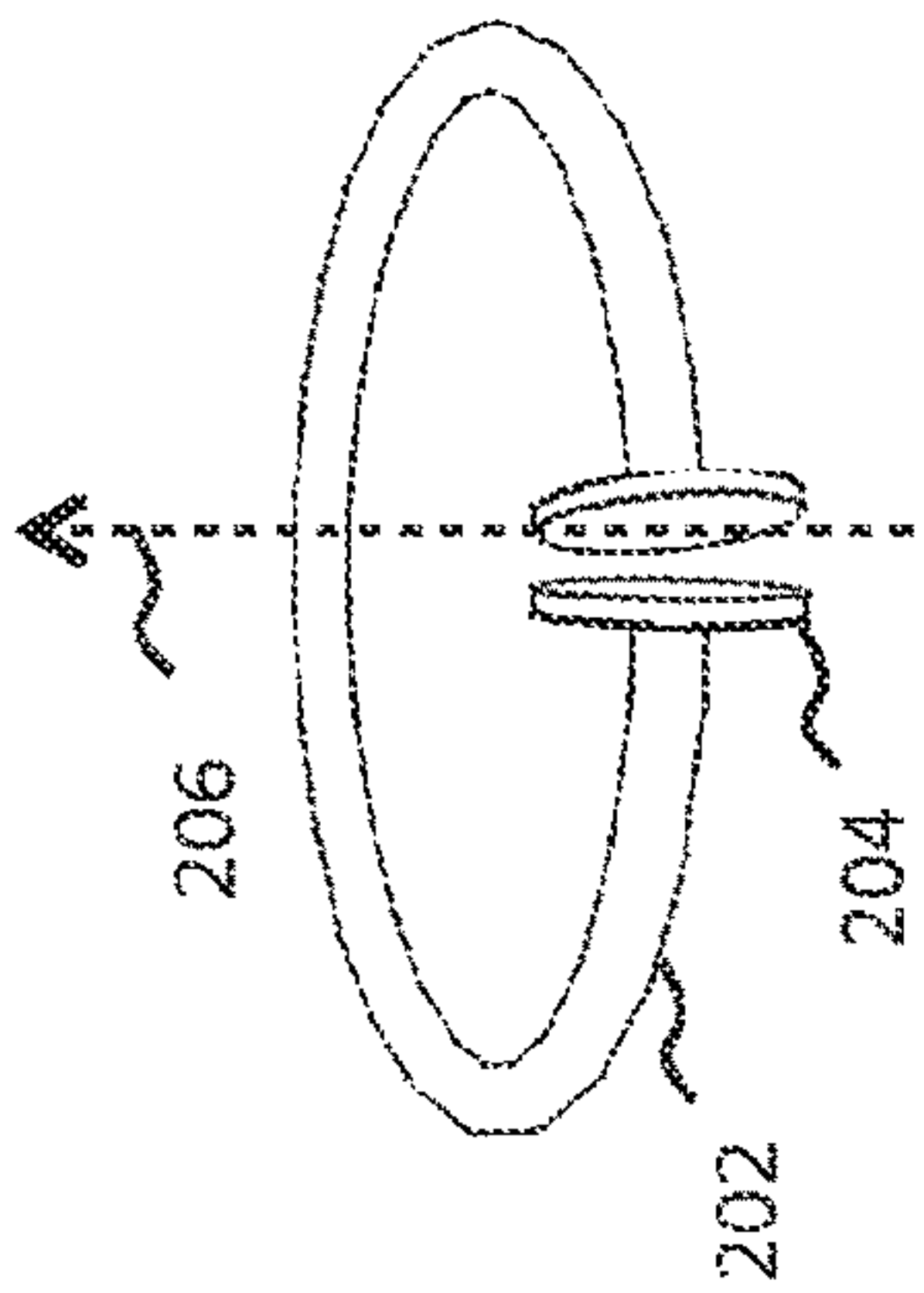

Fig. 2A

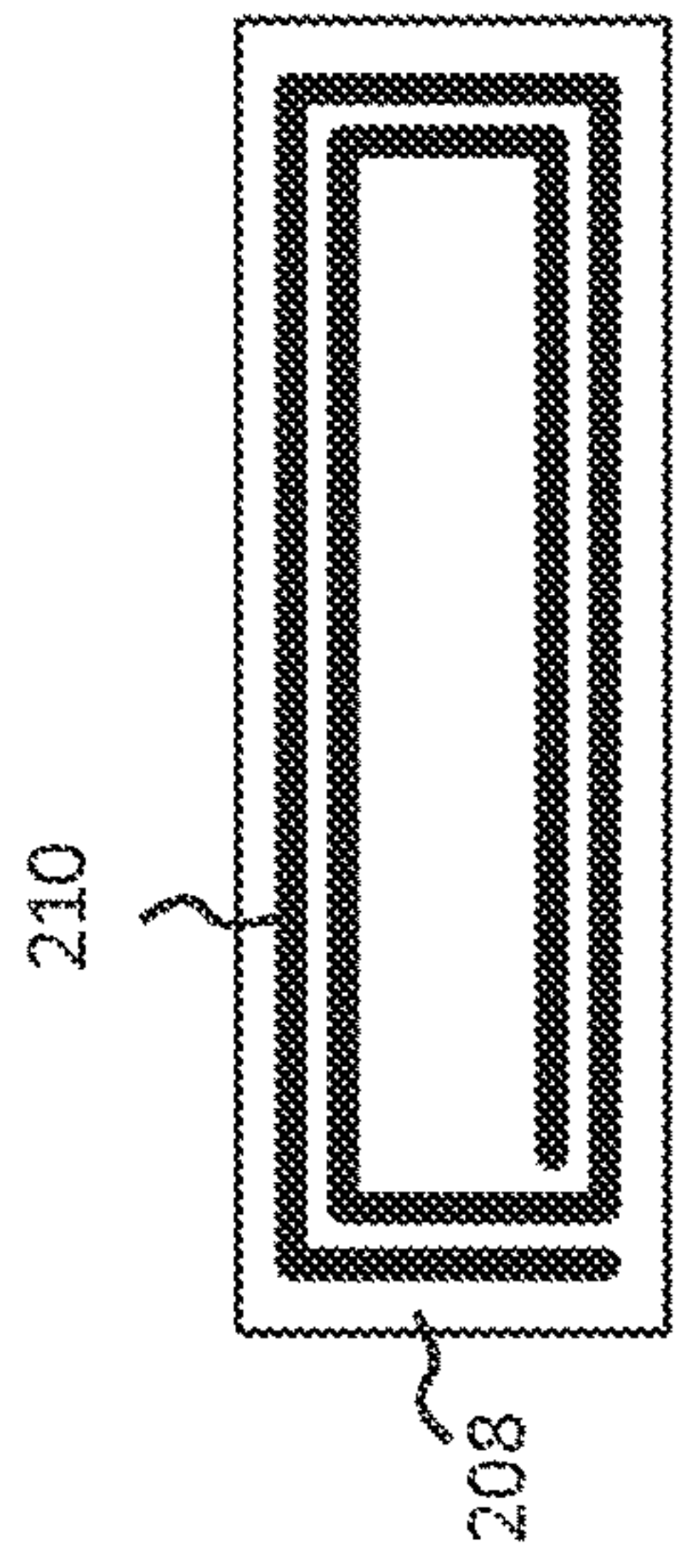

Fig. 2B

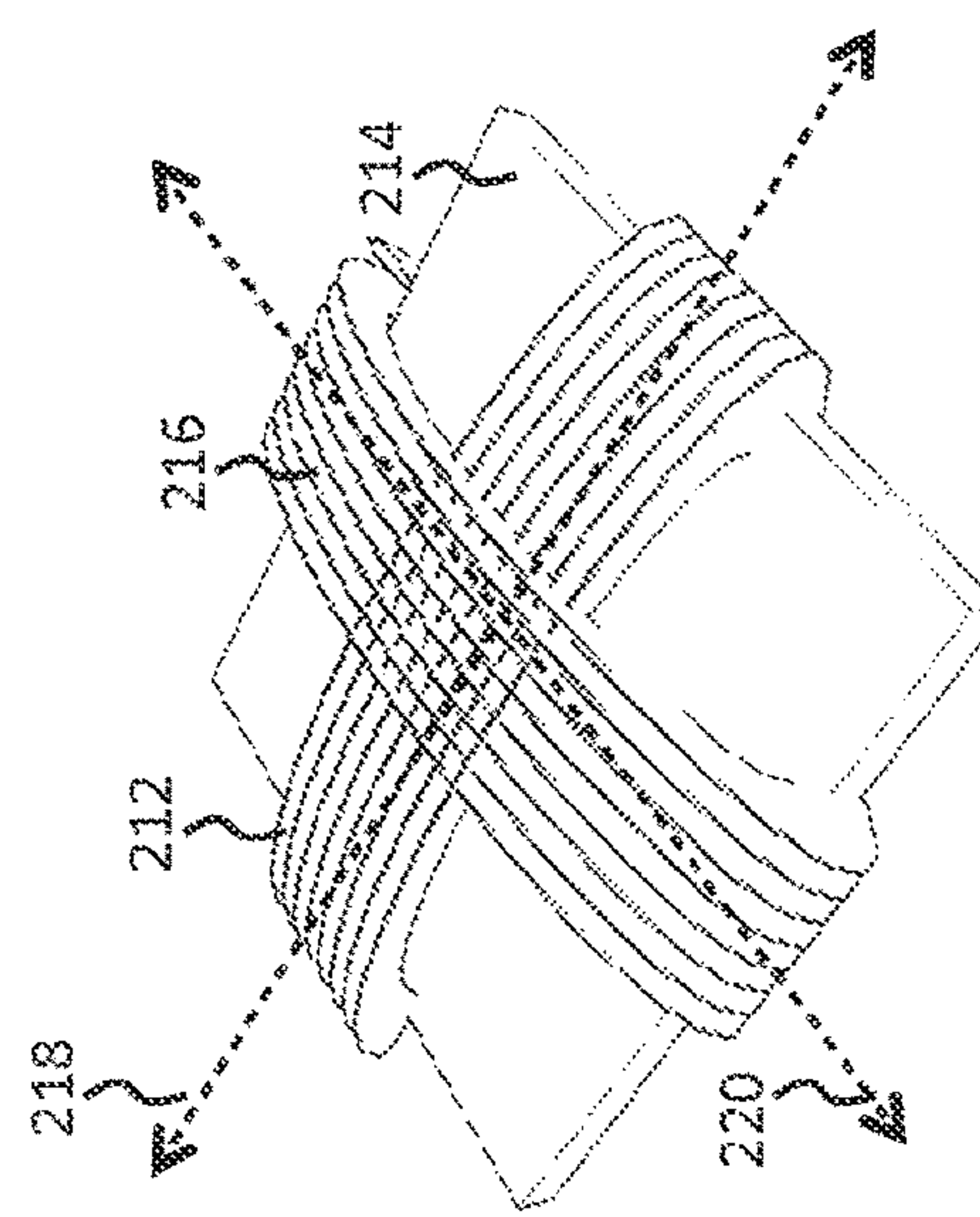

Fig. 2C

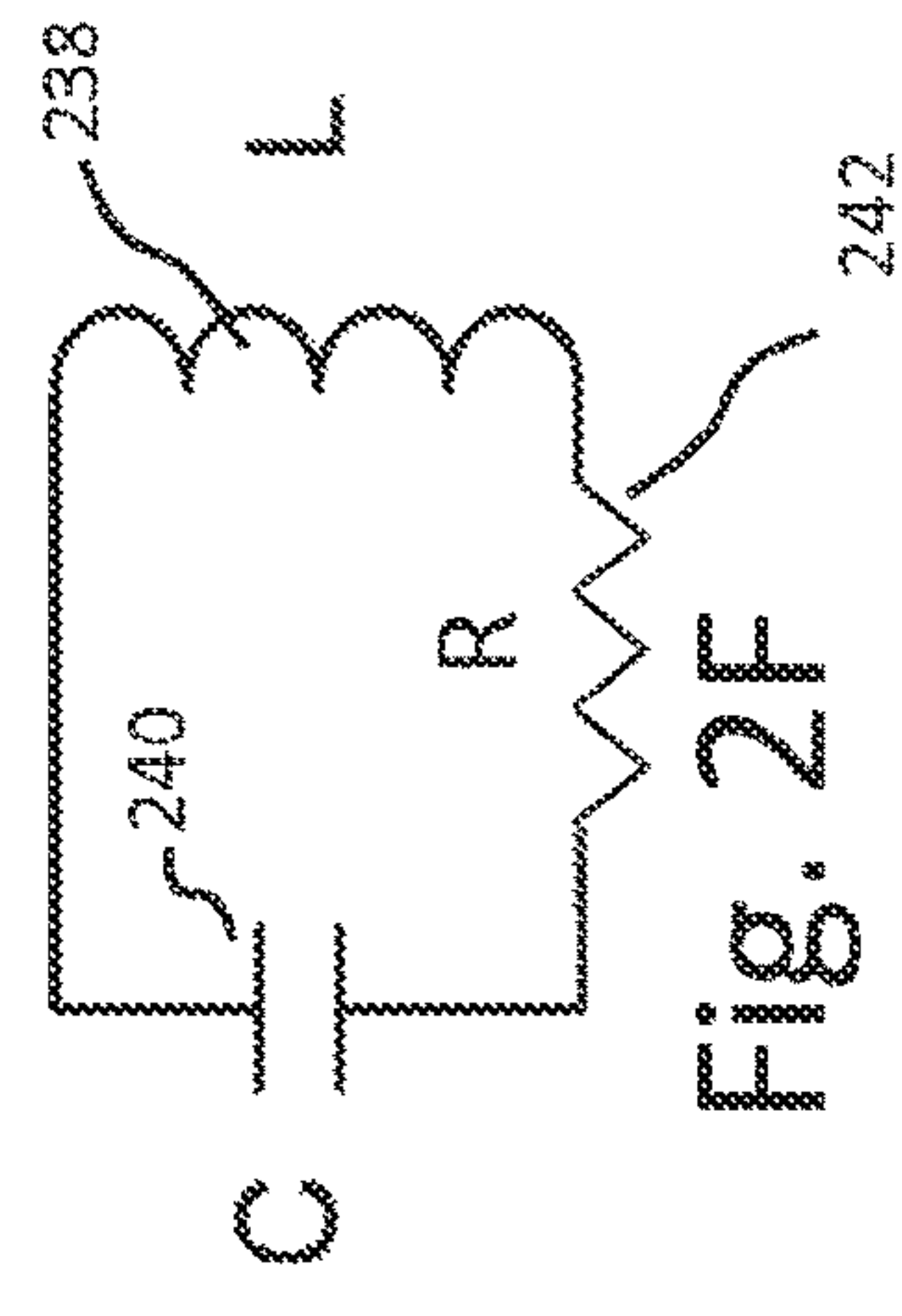

Fig. 2F

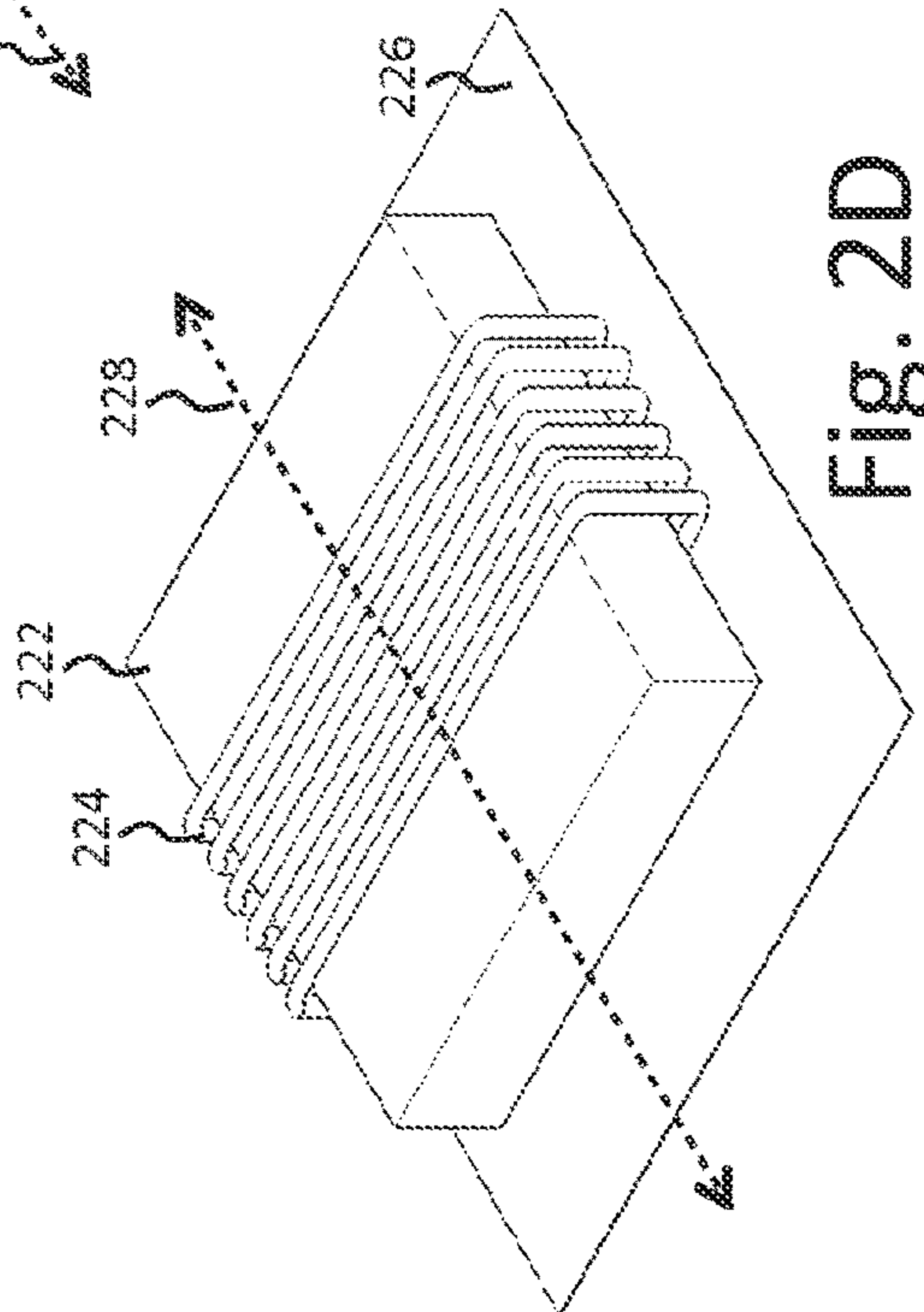

Fig. 2D

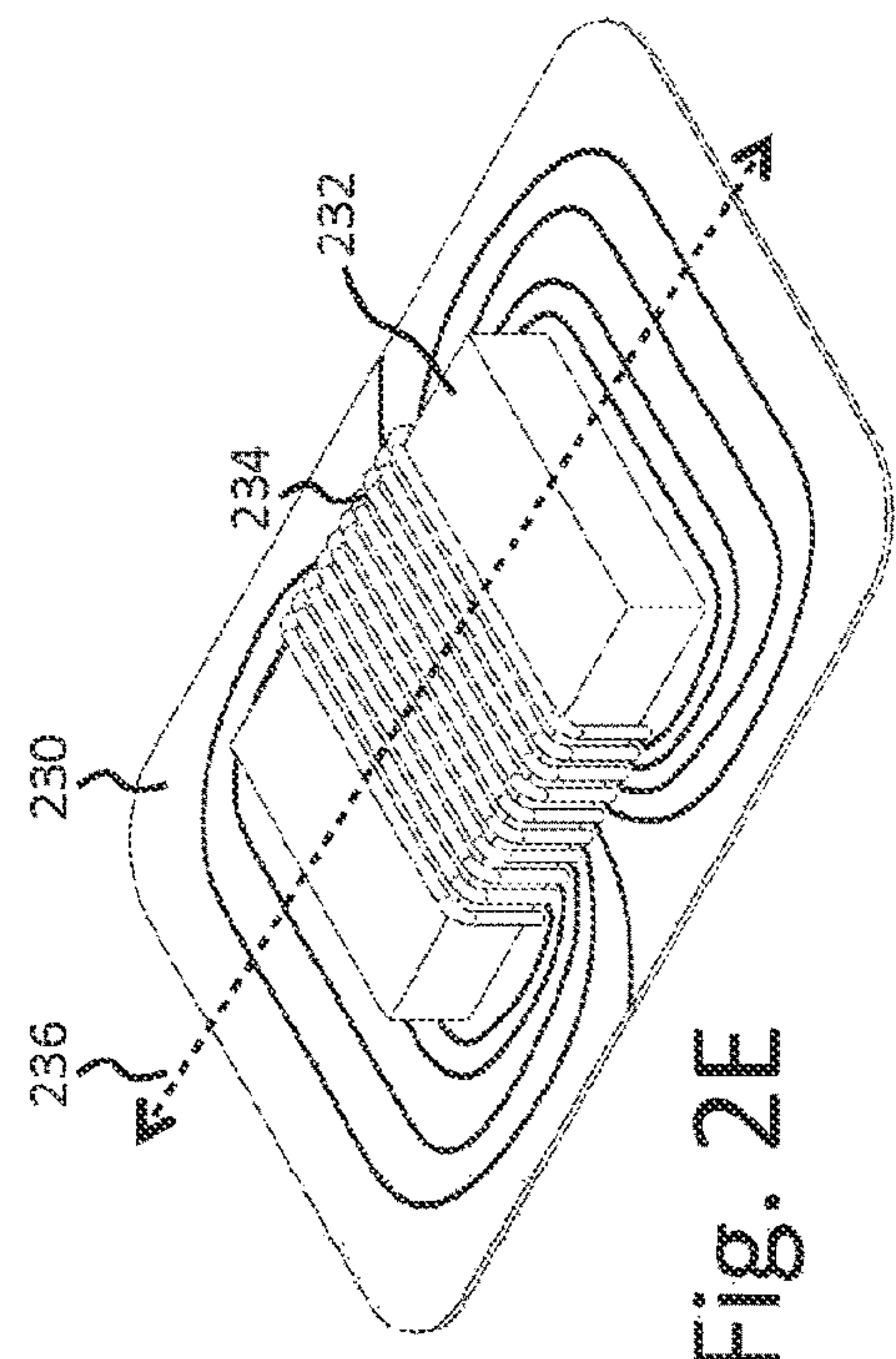

Fig. 2E











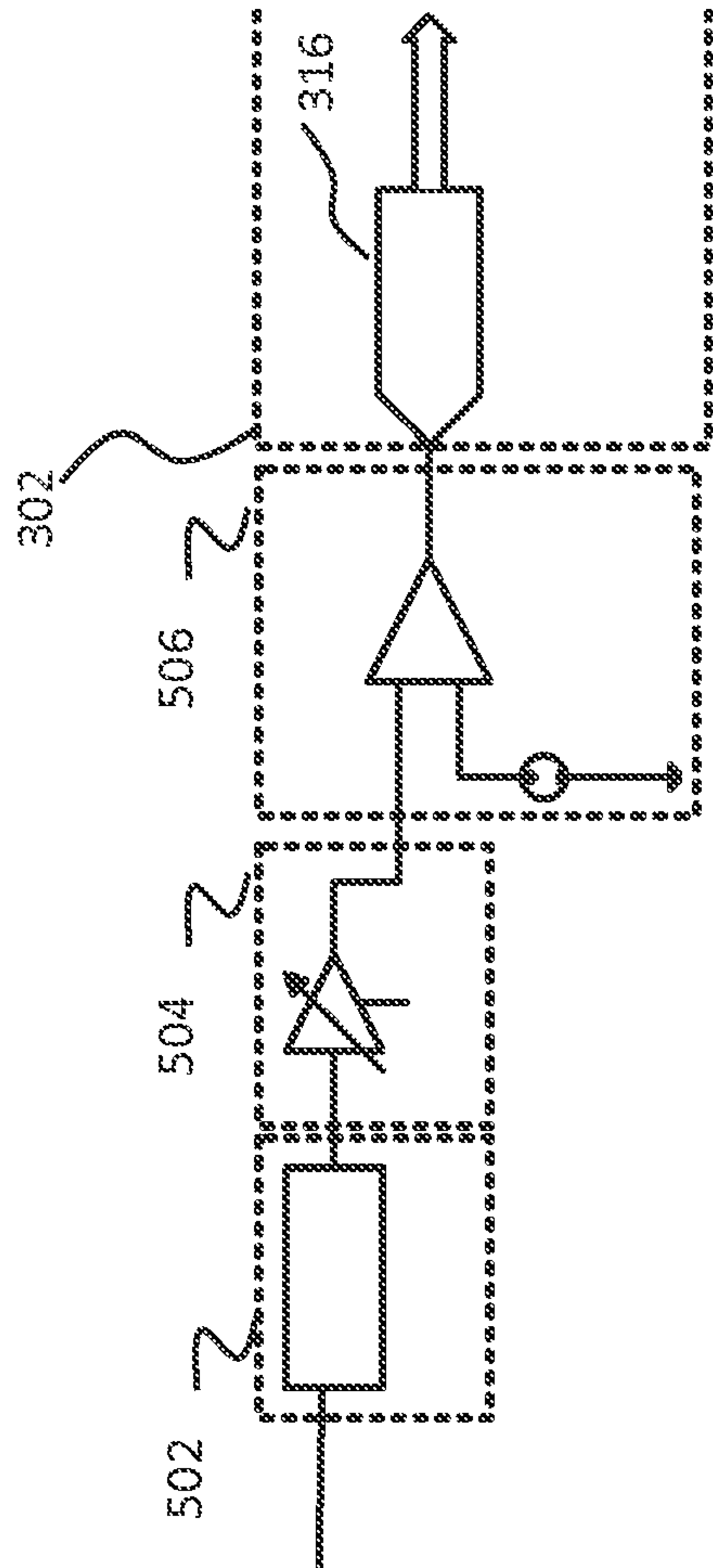

Fig. 5A

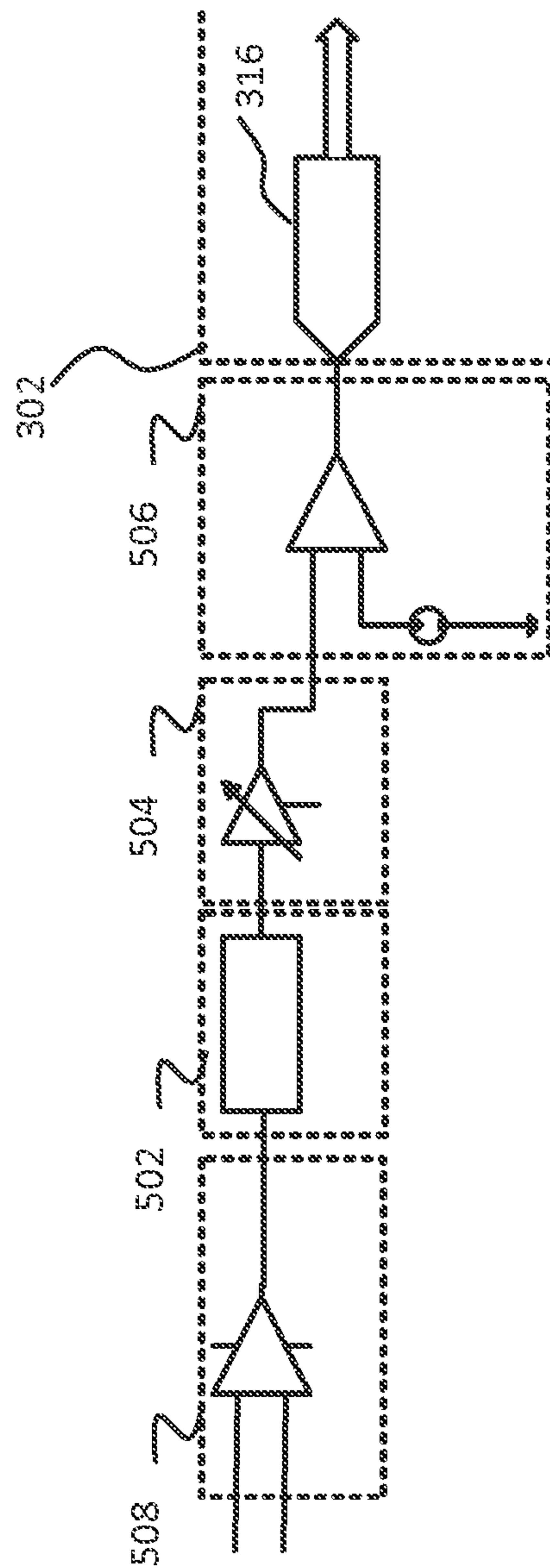

Fig. 5B



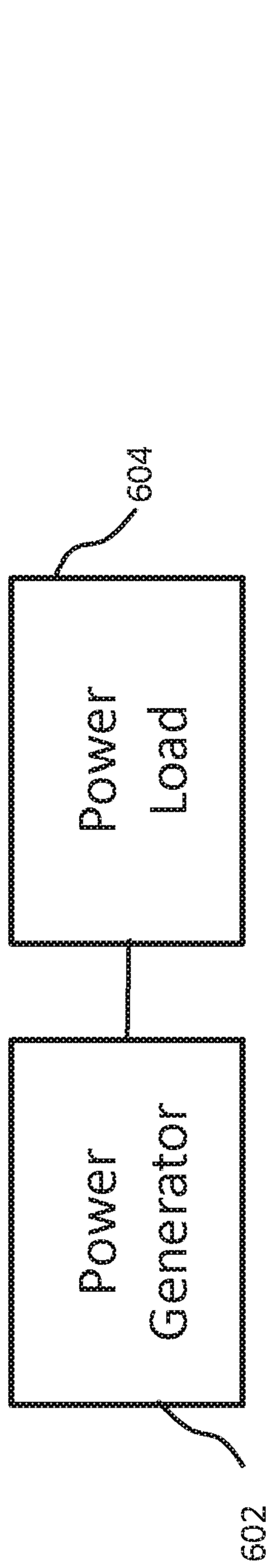

Fig. 6A

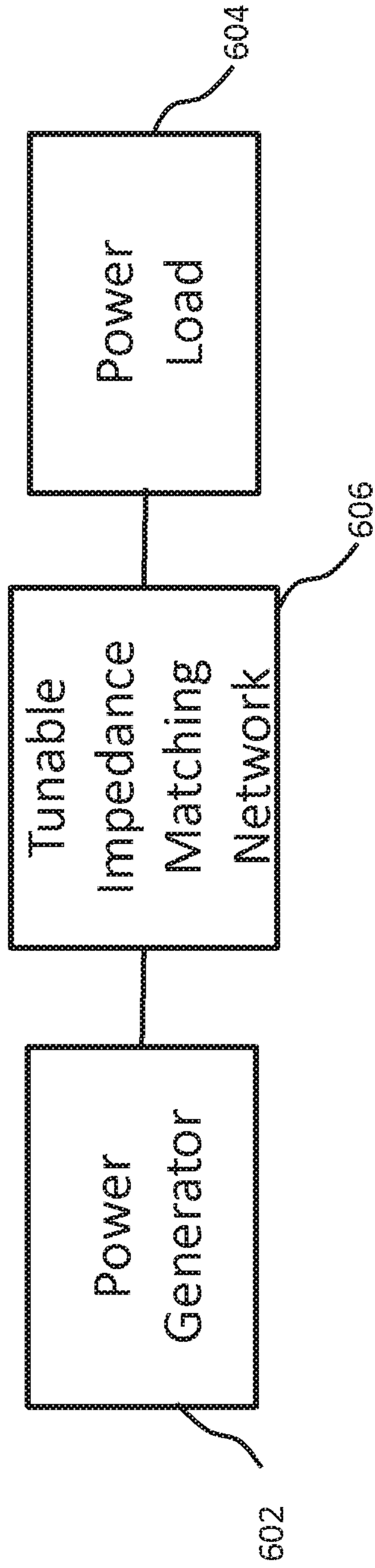

Fig. 6B

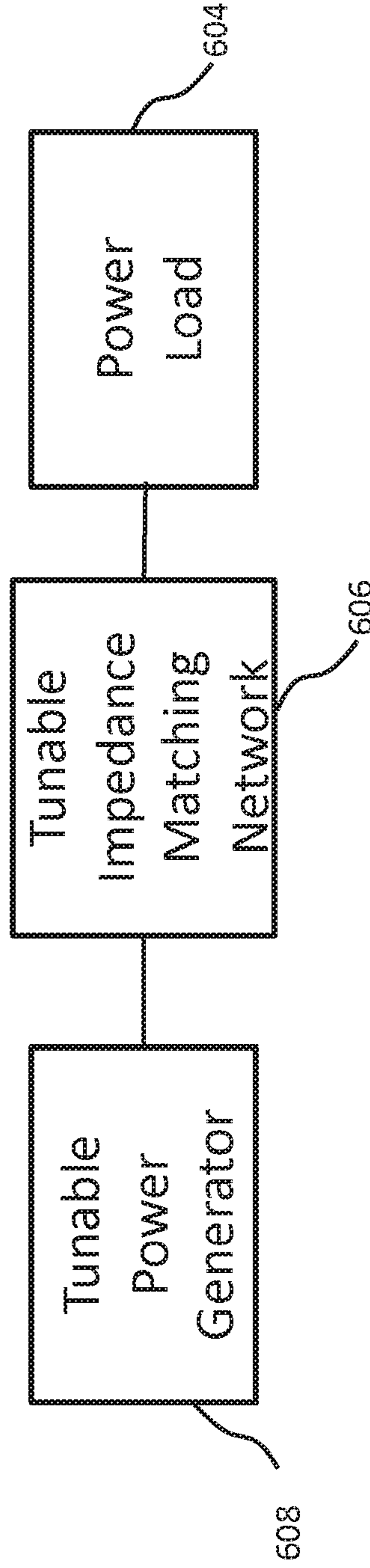

Fig. 6C



Fig. 7

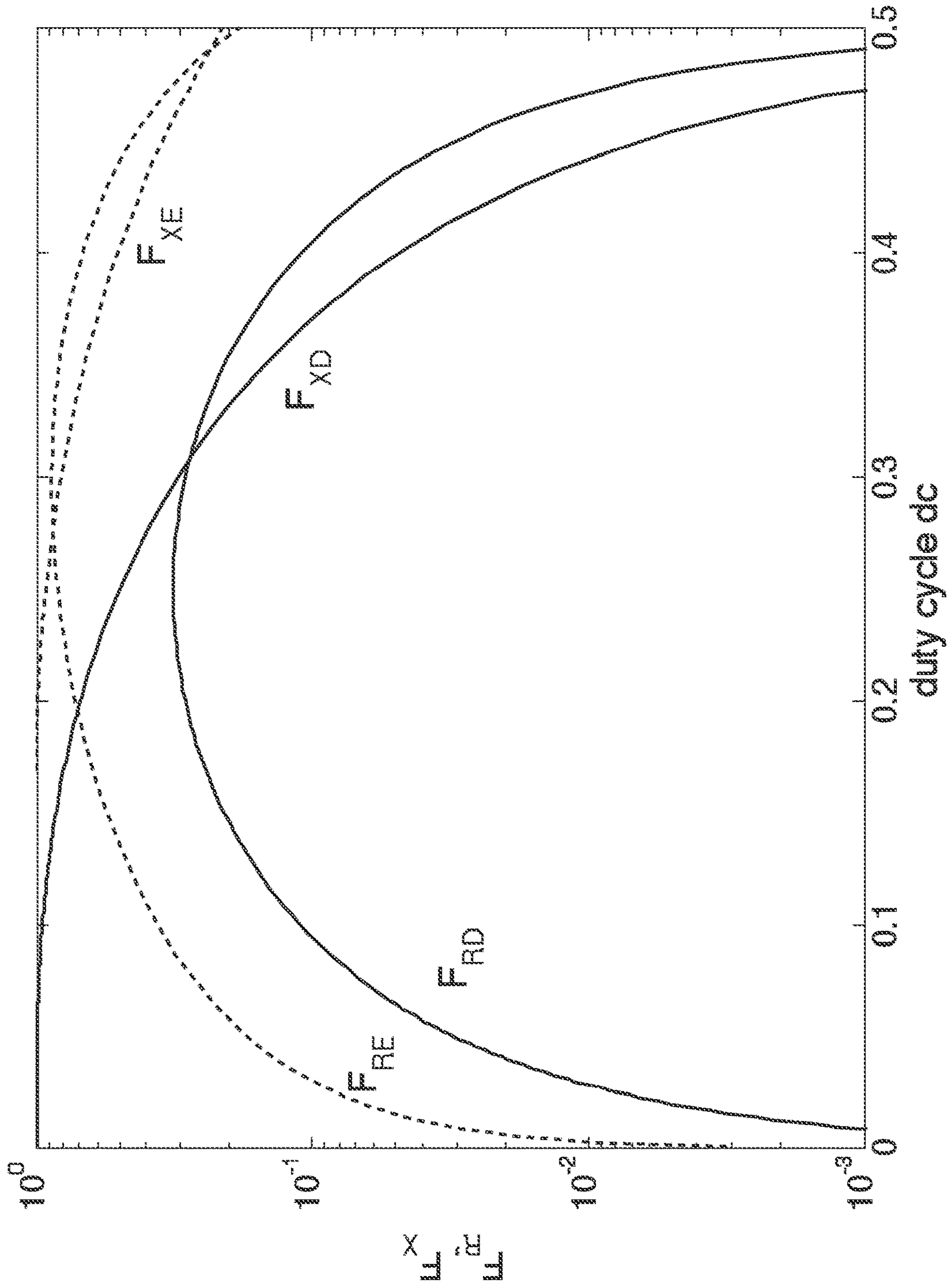



Fig. 8

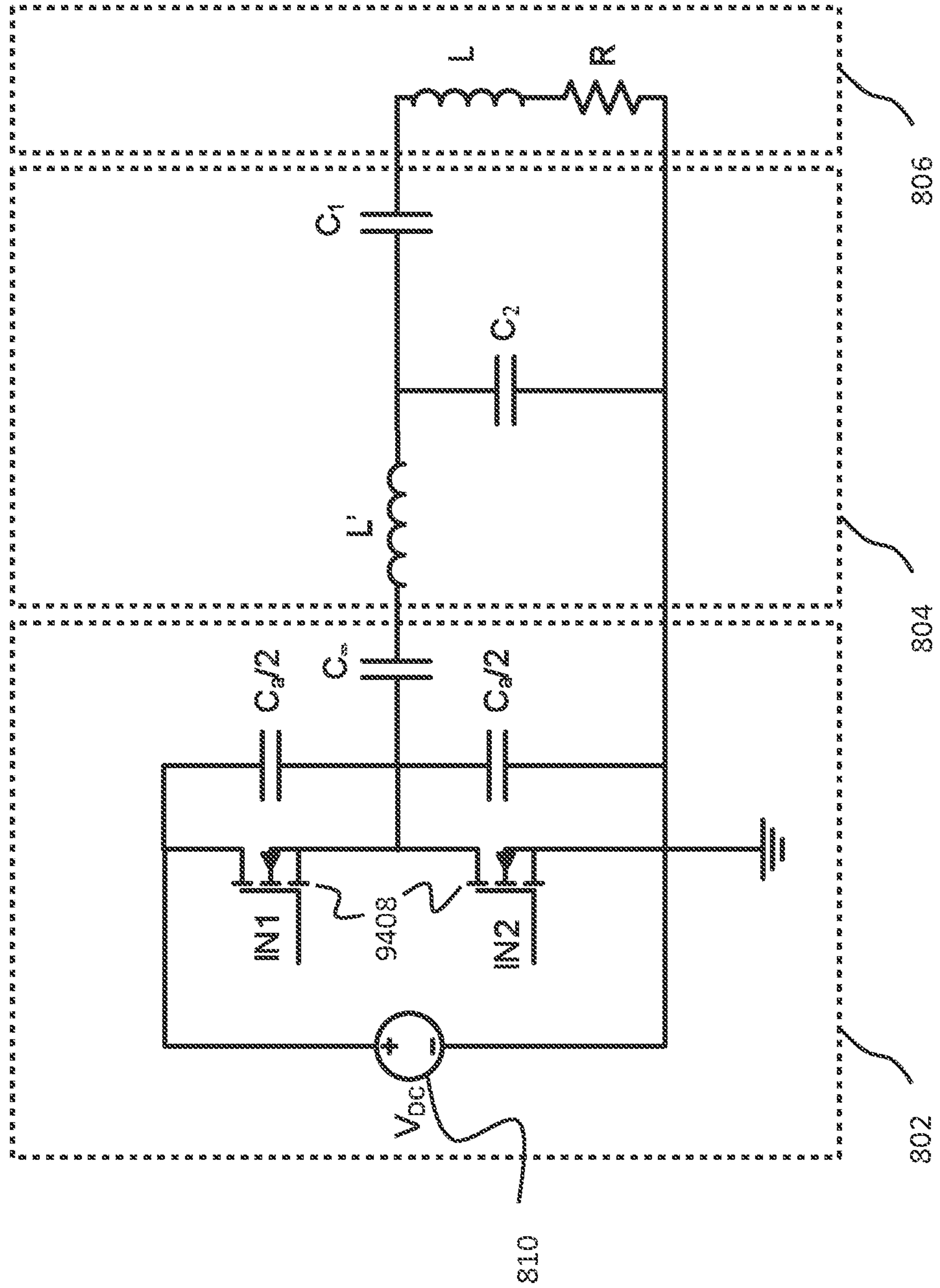

Fig. 9

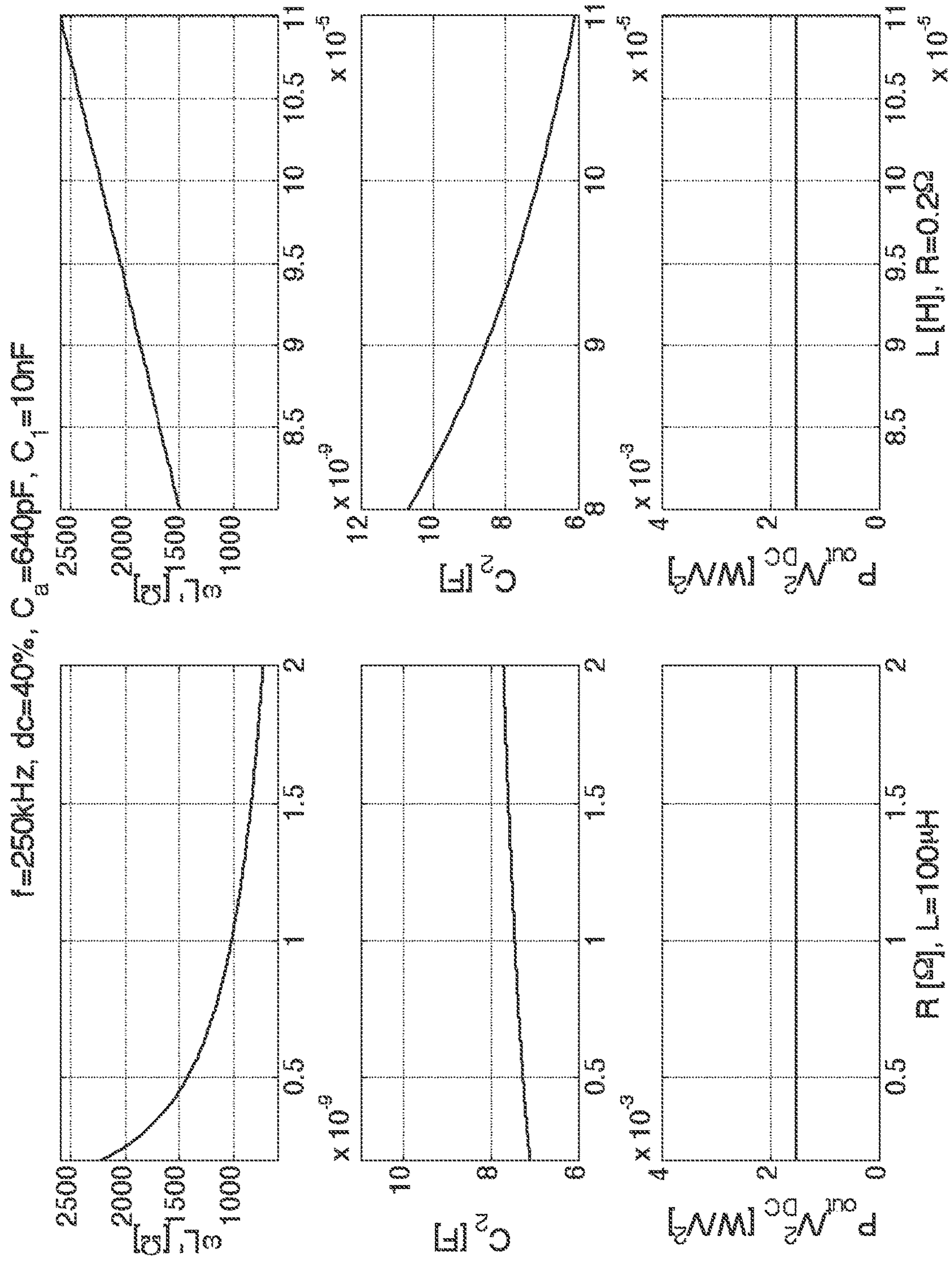



Fig. 10

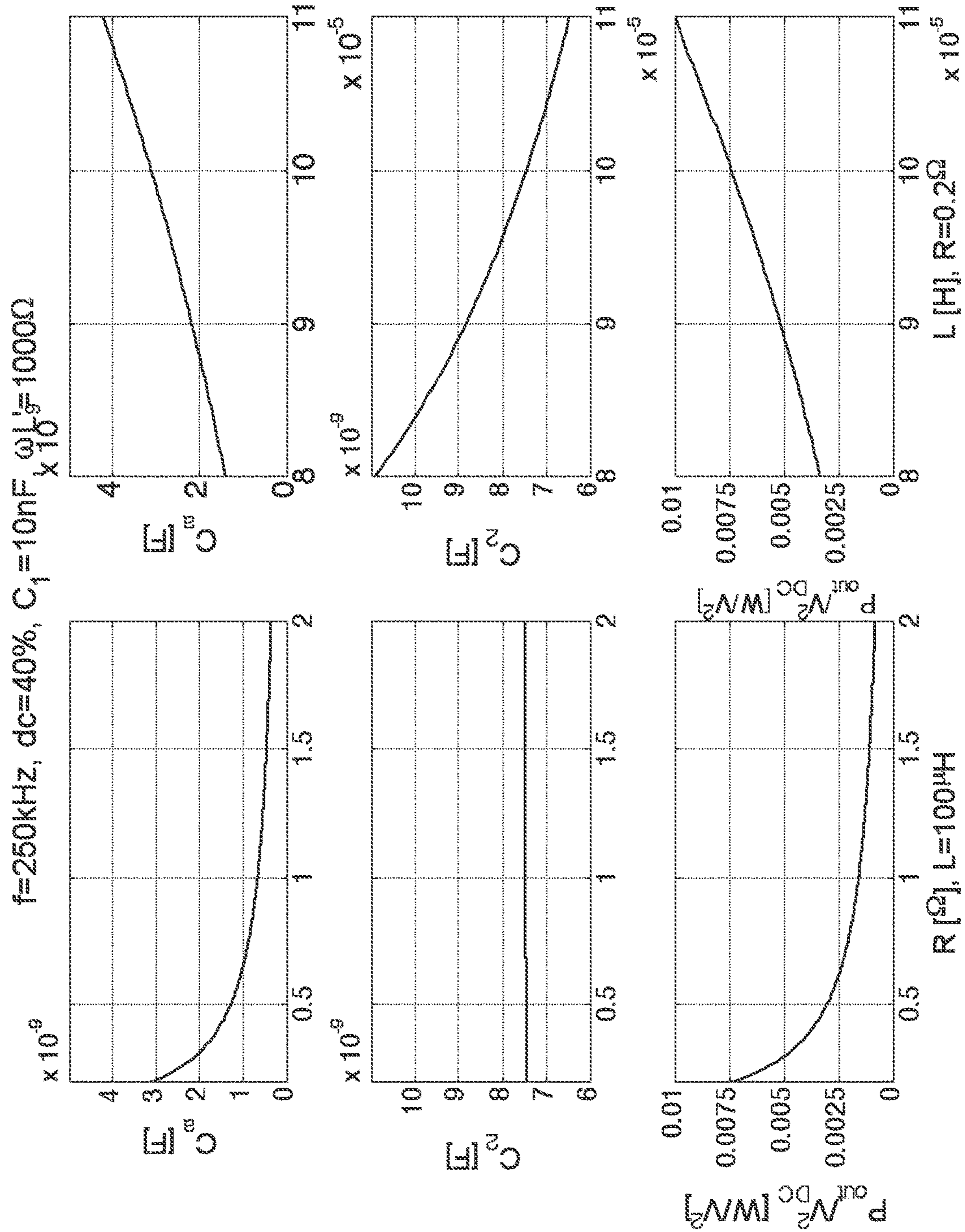

Fig. 11A

$f=250\text{kHz}$ ,  $dc=40\%$ ,  $C_1=10\text{nF}$ ,  $C_2=7.5\text{nF}$

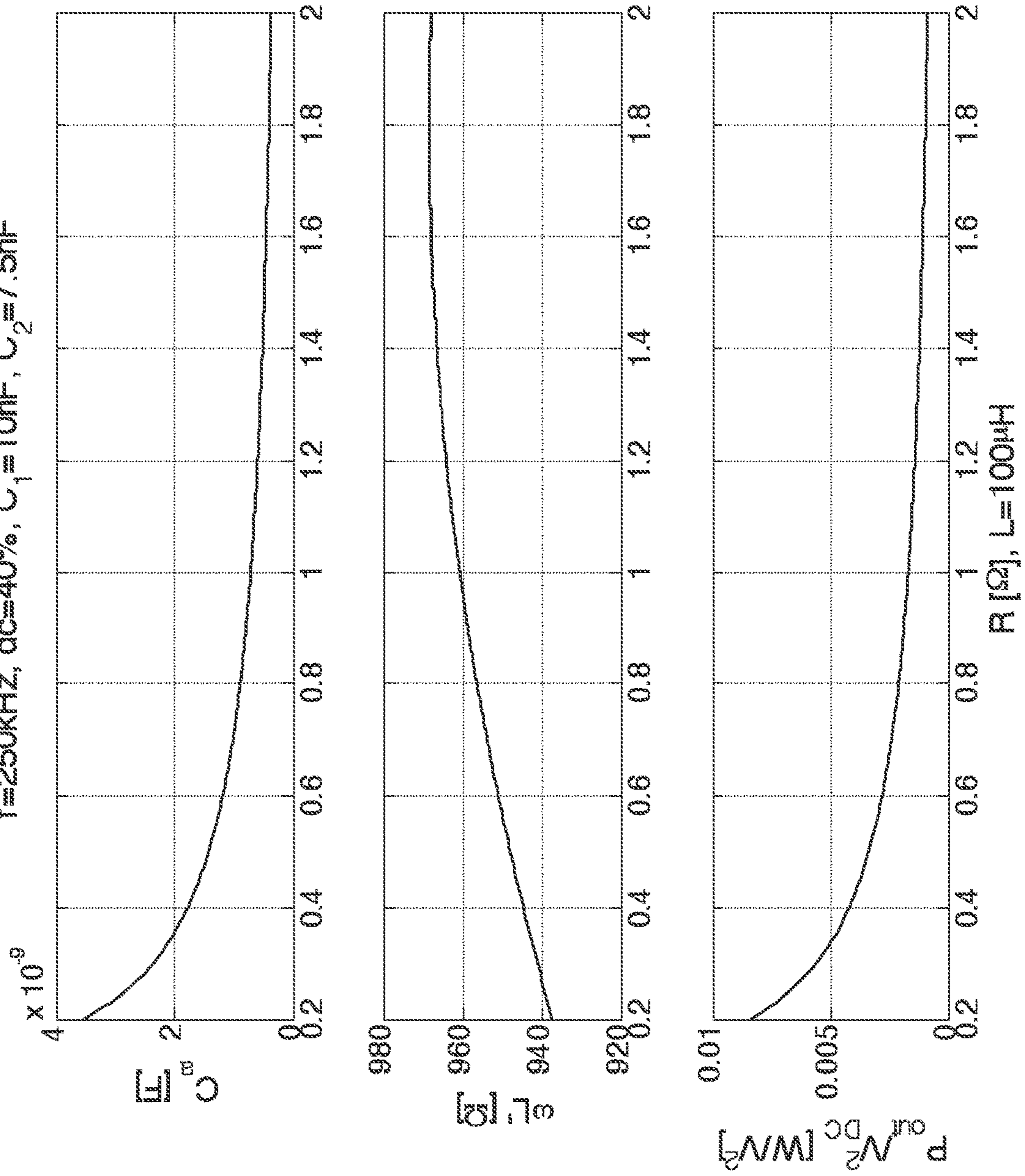



Fig. 11B

$f=250\text{kHz}$ ,  $dc=40\%$ ,  $C_1=10\text{nF}$ ,  $C_2=7.5\text{nF}$

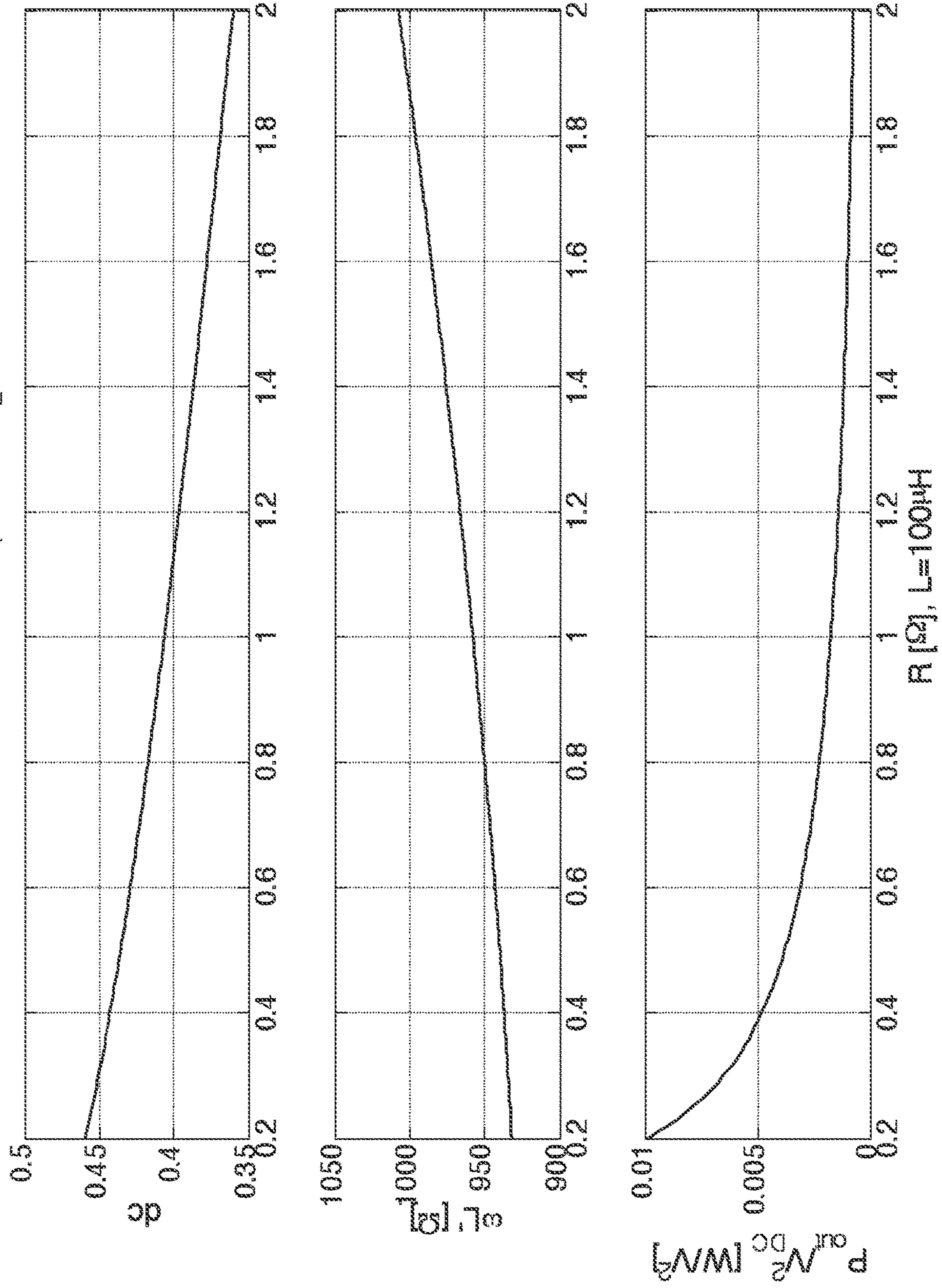

Fig. 11C

$f=250\text{kHz}$ ,  $C_1=10\text{nF}$ ,  $C_2=7.5\text{nF}$ ,  $\omega L=1000\Omega$

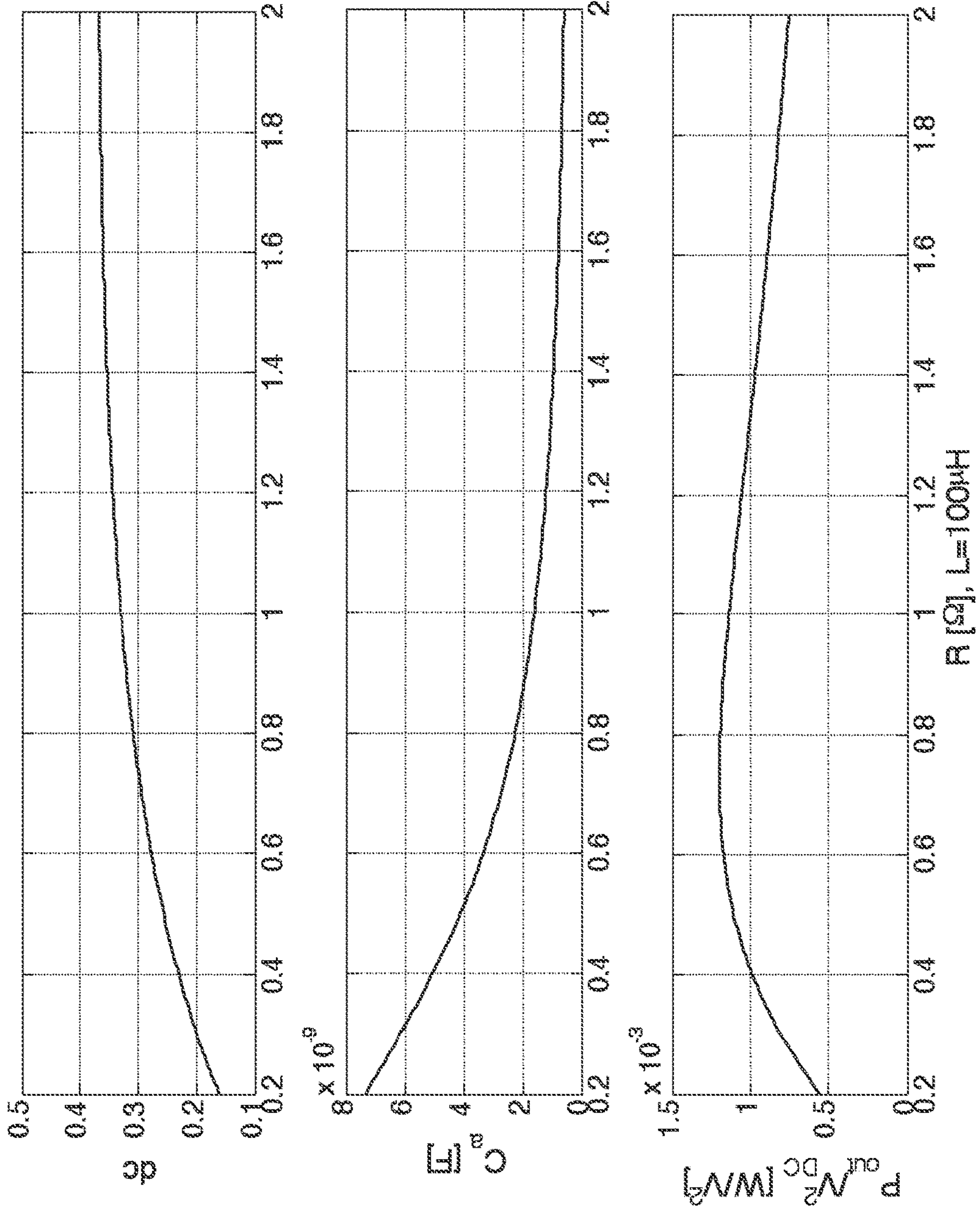



Fig. 12

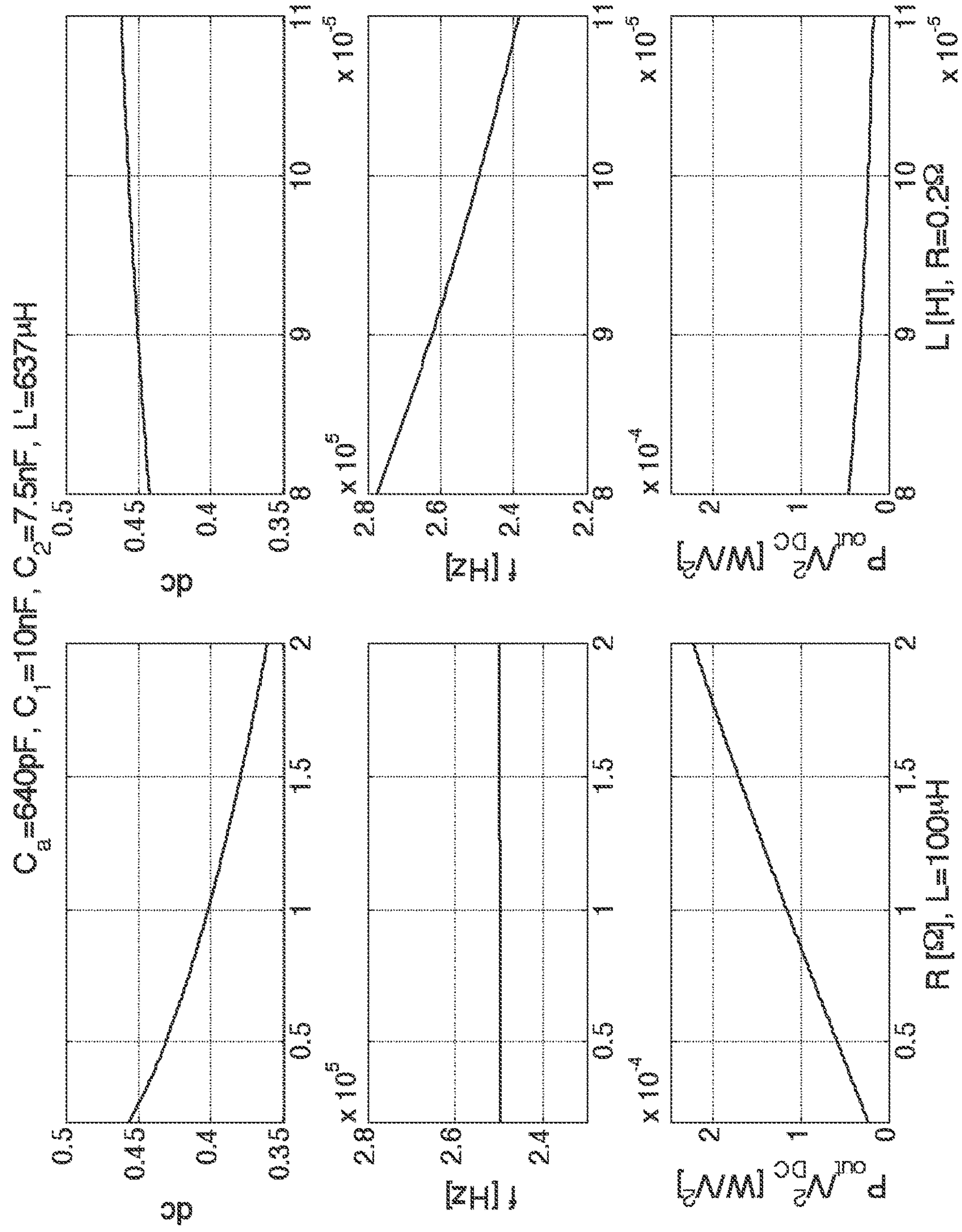

Fig. 13

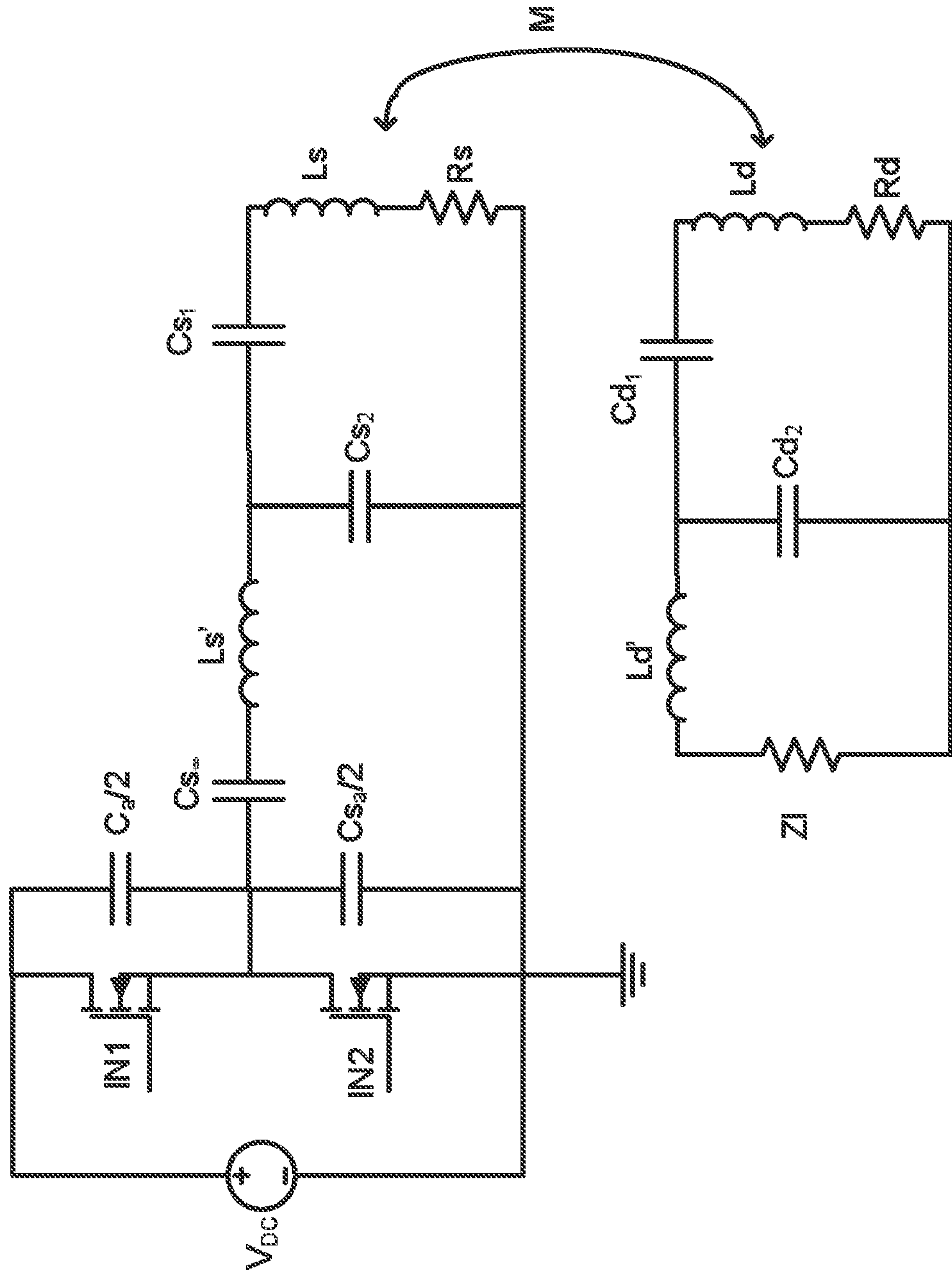
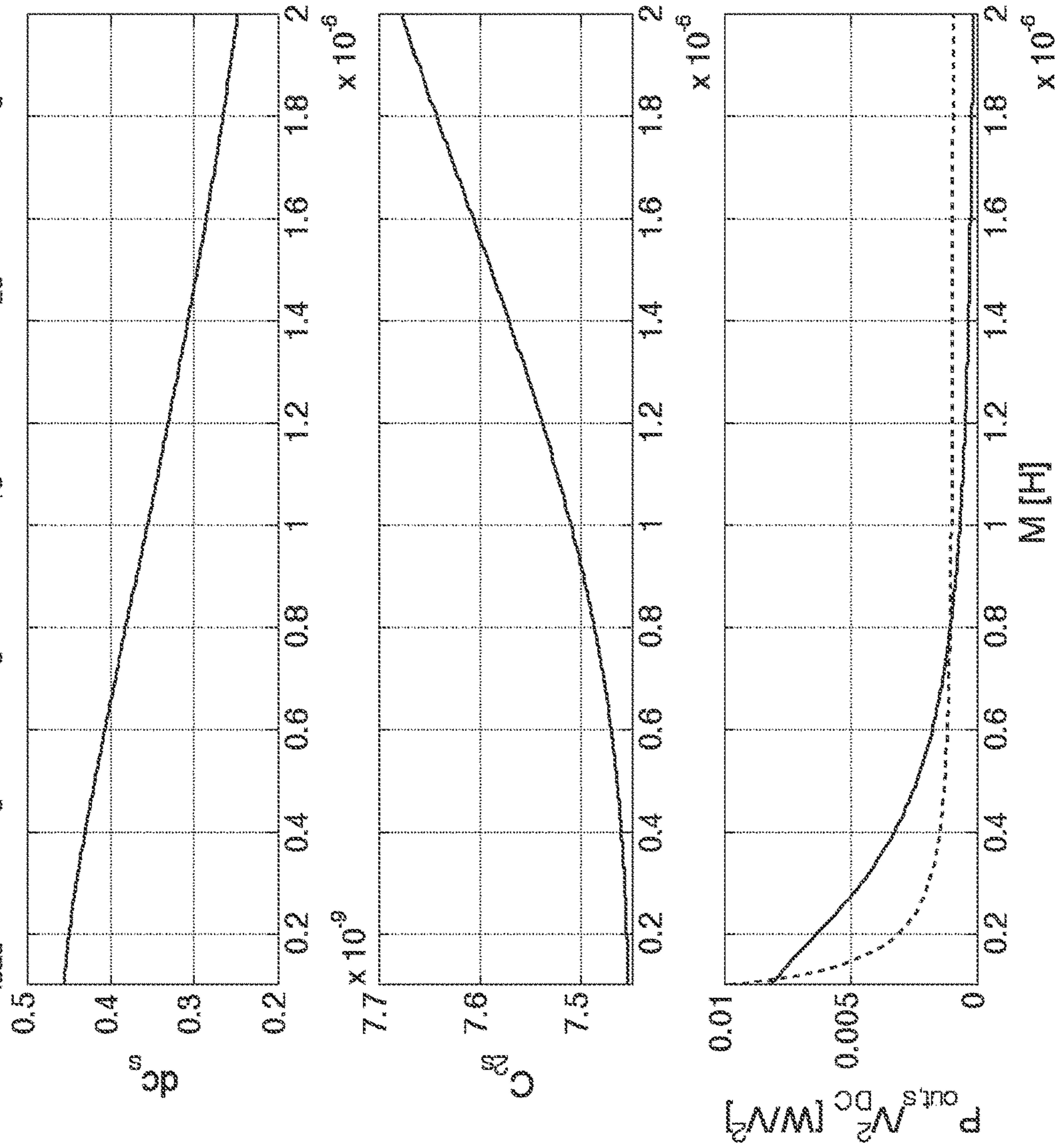



Fig. 14

$f=250\text{kHz}$ ,  $C_{as}=640\text{pF}$ ,  $R_s=0.19\Omega$ ,  $L_s=100\mu\text{H}$ ,  $C_{1s}=10\text{nF}$ ,  $\omega L'_s=1000\Omega$   
 $Z_{load}=50\Omega$ ,  $R_d=0.3\Omega$ ,  $L_d=40\mu\text{H}$ ,  $C_{1d}=87.5\text{nF}$ ,  $C_{2d}=13\text{nF}$ ,  $\omega L'_d=400\Omega$





# TUNABLE WIRELESS ENERGY TRANSFER SYSTEMS

## CROSS-REFERENCE TO RELATED APPLICATIONS

This application is a continuation of U.S. patent application Ser. No. 15/134,827, filed Apr. 21, 2016, which is a continuation of U.S. patent application Ser. No. 14/140,446 filed Dec. 24, 2013, which is a continuation of U.S. patent application Ser. No. 12/986,018 filed Jan. 6, 2011, which claims the benefit of U.S. Provisional Application No. 61/292,768 filed Jan. 6, 2010.

U.S. patent application Ser. No. 12/986,018 filed Jan. 6, 2011 is a continuation-in-part of U.S. patent application Ser. No. 12/789,611 filed May 28, 2010.

The Ser. No. 12/789,611 application is a continuation-in-part of U.S. patent application Ser. No. 12/770,137 filed Apr. 29, 2010 which claims the benefit of U.S. Provisional Application No. 61/173,747 filed Apr. 29, 2009.

The Ser. No. 12/770,137 application is a continuation-in-part of U.S. application Ser. No. 12/767,633 filed Apr. 26, 2010, which claims the benefit of U.S. Provisional Application No. 61/172,633 filed Apr. 24, 2009.

Application Ser. No. 12/767,633 is a continuation-in-part of U.S. application Ser. No. 12/759,047 filed Apr. 13, 2010 which is a continuation-in-part of U.S. application Ser. No. 12/757,716 filed Apr. 9, 2010, which is a continuation-in-part of U.S. application Ser. No. 12/749,571 filed Mar. 30, 2010.

The Ser. No. 12/749,571 application is a continuation-in-part of the following U.S. Applications: U.S. application Ser. No. 12/639,489 filed Dec. 16, 2009; and U.S. application Ser. No. 12/647,705 filed Dec. 28, 2009.

The Ser. No. 12/749,571 application a continuation-in-part of U.S. application Ser. No. 12/567,716 filed Sep. 25, 2009, which claims the benefit of the following U.S. patent applications: U.S. App. No. 61/100,721 filed Sep. 27, 2008; U.S. App. No. 61/108,743 filed Oct. 27, 2008; U.S. App. No. 61/147,386 filed Jan. 26, 2009; U.S. App. No. 61/152,086 filed Feb. 12, 2009; U.S. App. No. 61/178,508 filed May 15, 2009; U.S. App. No. 61/182,768 filed Jun. 1, 2009; U.S. App. No. 61/121,159 filed Dec. 9, 2008; U.S. App. No. 61/142,977 filed Jan. 7, 2009; U.S. App. No. 61/142,885 filed Jan. 6, 2009; U.S. App. No. 61/142,796 filed Jan. 6, 2009; U.S. App. No. 61/142,889 filed Jan. 6, 2009; U.S. App. No. 61/142,880 filed Jan. 6, 2009; U.S. App. No. 61/142,818 filed Jan. 6, 2009; U.S. App. No. 61/142,887 filed Jan. 6, 2009; U.S. App. No. 61/156,764 filed Mar. 2, 2009; U.S. App. No. 61/143,058 filed Jan. 7, 2009; U.S. App. No. 61/163,695 filed Mar. 26, 2009; U.S. App. No. 61/172,633 filed Apr. 24, 2009; U.S. App. No. 61/169,240 filed Apr. 14, 2009, U.S. App. No. 61/173,747 filed Apr. 29, 2009.

The Ser. No. 12/757,716 application is a continuation-in-part of U.S. application Ser. No. 12/721,118 filed Mar. 10, 2010, which is a continuation-in-part of U.S. application Ser. No. 12/705,582 filed Feb. 13, 2010 which claims the benefit of U.S. Provisional Application No. 61/152,390 filed Feb. 13, 2009.

Each of the foregoing applications is incorporated herein by reference in its entirety.

# BACKGROUND

## Field

5 This disclosure relates to wireless energy transfer, methods, systems and apparatus to accomplish such transfer, and applications.

## Description of the Related Art

10 Energy or power may be transferred wirelessly using a variety of techniques as detailed, for example, in commonly owned U.S. patent application Ser. No. 12/789,611 published on Sep. 23, 2010 as U.S. Pat. Pub. No. 2010/0237709 and entitled "RESONATOR ARRAYS FOR WIRELESS ENERGY TRANSFER," and U.S. patent application Ser. No. 12/722,050 published on Jul. 22, 2010 as U.S. Pat. Pub. No. 2010/0181843 and entitled "WIRELESS ENERGY TRANSFER FOR REFRIGERATOR APPLICATION" the contents of which are incorporated in their entirety as if fully set forth herein. Prior art wireless energy transfer systems have been limited by a variety of factors including concerns over user safety, low energy transfer efficiencies and restrictive physical proximity/alignment tolerances for the energy supply and sink components.

15 One particular challenge in wireless energy transfer is control and tuning of the resonator structures and the power source. Other resonators, temperature, extraneous objects, and the like may affect the parameters of the resonators. The impedance, resonant frequency, loading conditions, and/or parameters of electrical components, and the like, may fluctuate during operation of the wireless energy transfer system. For example, a large conducting object brought close to a resonator may detune the resonator from its nominal resonant frequency, which detuning may affect the efficiency of wireless power transfer and may also affect the efficiency and amount of power transferred from the power source to the resonator.

20 In some embodiments parameters of the resonator, power source, and the like may need to be changed or tuned to control the operating point of the resonator or the system. For example, the resonant frequency of a resonator may need to be periodically changed to match the frequencies of nearby resonators that may be tuned to different frequencies. Changing the resonant frequency of a wireless source may require changes to the operating parameters of the power source to maintain high or optimum efficiency and power.

25 Therefore a need exists for methods and designs for tuning components of a wireless energy transfer system.

## SUMMARY

30 Various systems and processes, in various embodiments, provide wireless energy transfer using coupled resonators. In some embodiments, the resonator structures may require or benefit from tuning of the components of the resonators. Resonators, electrical components, and parameters of an energy source may require tuning to maintain a specific level of efficiency or performance. The features of such embodiments are general and may be applied to a wide range of resonators, regardless of the specific examples discussed herein.

35 In embodiments, a magnetic resonator may comprise some combination of inductors and capacitors. Additional circuit elements such as capacitors, inductors, resistors, switches, and the like, may be inserted between a magnetic resonator and a power source, and/or between a magnetic



resonator and a power load. In this disclosure, the conducting coil that comprises the high-Q inductive loop of the resonator may be referred to as the inductor and/or the inductive load. The inductive load may also refer to the inductor when it is wirelessly coupled (through a mutual inductance) to other system or extraneous objects. In this disclosure, circuit elements other than the inductive load may be referred to as being part of an impedance matching network or IMN. It is to be understood that all, some, or none of the elements that are referred to as being part of an impedance matching network may be part of the magnetic resonator. Which elements are part of the resonator and which are separate from the resonator will depend on the specific magnetic resonator and wireless energy transfer system design.

In one aspect, the switching amplifier of the power source has a variable duty cycle. The duty cycle of the switching amplifier may be adjusted ensuring zero voltage or zero current switching as the parameters of an inductive load change.

In another aspect the switching amplifier of the power source has a variable duty cycle and the elements of an impedance matching network and/or a resonator comprise at least one variable capacitor or inductor. The duty cycle of the switching amplifier along with the variable capacitor or inductor may be adjusted allowing dynamic impedance matching between the switching amplifier and the resonator.

In yet another aspect, the switching amplifier of the power source has a variable duty cycle and a variable bus voltage and the elements of an impedance matching network and/or resonator comprise at least one variable capacitor or inductor. The duty cycle of the switching amplifier along with the variable capacitor or inductor may be adjusted allowing dynamic impedance matching between the switching amplifier and the resonator and the variable bus voltage allows dynamic power control.

Unless otherwise indicated, this disclosure uses the terms wireless energy transfer, wireless power transfer, wireless power transmission, and the like, interchangeably. Those skilled in the art will understand that a variety of system architectures may be supported by the wide range of wireless system designs and functionalities described in this application.

In the wireless energy transfer systems described herein, power may be exchanged wirelessly between at least two resonators. Resonators may supply, receive, hold, transfer, and distribute energy. Sources of wireless power may be referred to as sources or supplies and receivers of wireless power may be referred to as devices, receivers and power loads. A resonator may be a source, a device, or both, simultaneously or may vary from one function to another in a controlled manner. Resonators configured to hold or distribute energy that do not have wired connections to a power supply or power drain may be called repeaters.

The resonators of the wireless energy transfer systems of this invention are able to transfer power over distances that are large compared to the size of the resonators themselves. That is, if the resonator size is characterized by the radius of the smallest sphere that could enclose the resonator structure, the wireless energy transfer system of this invention can transfer power over distances greater than the characteristic size of a resonator. The system is able to exchange energy between resonators where the resonators have different characteristic sizes and where the inductive elements of the resonators have different sizes, different shapes, are comprised of different materials, and the like.

The wireless energy transfer systems of this invention may be described as having a coupling region, an energized area or volume, all by way of describing that energy may be transferred between resonant objects that are separated from each other, they may have variable distance from each other, and that may be moving relative to each other. In some embodiments, the area or volume over which energy can be transferred is referred to as the active field area or volume. In addition, the wireless energy transfer system may comprise more than two resonators that may each be coupled to a power source, a power load, both, or neither.

Wirelessly supplied energy may be used to power electric or electronic equipment, recharge batteries or charge energy storage units. Multiple devices may be charged or powered simultaneously or power delivery to multiple devices may be serialized such that one or more devices receive power for a period of time after which power delivery may be switched to other devices. In various embodiments, multiple devices may share power from one or more sources with one or more other devices either simultaneously, or in a time multiplexed manner, or in a frequency multiplexed manner, or in a spatially multiplexed manner, or in an orientation multiplexed manner, or in any combination of time and frequency and spatial and orientation multiplexing. Multiple devices may share power with each other, with at least one device being reconfigured continuously, intermittently, periodically, occasionally, or temporarily, to operate as a wireless power source. Those of ordinary skill in the art will understand that there are a variety of ways to power and/or charge devices applicable to the technologies and applications described herein.

This disclosure references certain individual circuit components and elements such as capacitors, inductors, resistors, diodes, transformers, switches and the like; combinations of these elements as networks, topologies, circuits, and the like; and objects that have inherent characteristics such as "self-resonant" objects with capacitance or inductance distributed (or partially distributed, as opposed to solely lumped) throughout the entire object. It would be understood by one of ordinary skill in the art that adjusting and controlling variable components within a circuit or network may adjust the performance of that circuit or network and that those adjustments may be described generally as tuning, adjusting, matching, correcting, and the like. Other methods to tune or adjust the operating point of the wireless power transfer system may be used alone, or in addition to adjusting tunable components such as inductors and capacitors, or banks of inductors and capacitors. Those skilled in the art will recognize that a particular topology discussed in this disclosure can be implemented in a variety of other ways.

In embodiments, in a system adapted for wireless power transfer, a tunable resonant amplifier circuit may be provided for driving an inductive load having a varying impedance, the circuit comprising: a switching amplifier with a variable duty cycle; an inductive load; a connection between the inductive load and the switching amplifier, the connection including at least one tunable component; and a feedback loop for adjusting the at least one tunable component and the duty cycle of the amplifier, wherein the feedback loop adjusts the duty cycle of the amplifier and the at least one tunable component to maintain substantially zero voltage switching and zero current switching at the output of the amplifier under different load conditions of the inductive load. The at least one tunable component may include a tunable capacitor. The tunable capacitor may be in series with the inductive load. The tunable capacitor may be in parallel with the inductive load. The connection between the



## 5

inductive load and the switching amplifier may include more than one tunable component. The switching amplifier may use a variable switching frequency. A bus voltage of the switching amplifier may be variable and used to control an amount of power delivered to the inductive load. The feedback loop may include an impedance measuring facility. The feedback loop may include a processor, the processor configured to monitor an impedance at an output of the switching amplifier and to compute an adjustment to the variable duty cycle of the switching amplifier such that zero voltage switching is substantially maintained. The processor may be configured to compute a second adjustment to at least one tunable component such that zero current switching is substantially maintained. The inductive load may include a high-Q magnetic resonator. The circuit may be used as a source in a wireless power transmission system.

In embodiments, a method of tuning a resonant amplifier circuit in a wireless power transfer facility may be provided that includes a connection between a switching amplifier and an inductive load having a varying impedance, the method comprising the steps of: measuring a number of parameters at an output of the switching amplifier; adjusting a duty cycle of the switching amplifier; and adjusting at least one tunable component in the connection between the switching amplifier and the inductive load, wherein adjusting the duty cycle of the switching amplifier and adjusting at least one tunable component are controlled to maintain a substantially zero voltage switching and a substantially zero current switching at the output of the switching amplifier under different load conditions of the inductive load. The at least one tunable component may include a tunable capacitor. Measuring a number of parameters may include measuring an impedance at the output of the switching amplifier. Further, computing necessary adjustments to the duty cycle of the switching amplifier and adjustments to the at least one tunable component may be based on the impedance, to maintain substantially zero voltage and substantially zero current switching at the output of the switching amplifier. The inductive load and at least a part of the connection between the switching amplifier and the inductive load may form a high-Q magnetic resonator. The circuit may be used as a source in a wireless power transmission system.

Unless otherwise defined, all technical and scientific terms used herein have the same meaning as commonly understood by one of ordinary skill in the art to which this disclosure belongs. In case of conflict with publications, patent applications, patents, and other references mentioned or incorporated herein by reference, the present specification, including definitions, will control.

Any of the features described above may be used, alone or in combination, without departing from the scope of this disclosure. Other features, objects, and advantages of the systems and methods disclosed herein will be apparent from the following detailed description and figures.

## BRIEF DESCRIPTION OF FIGURES

FIG. 1 is a system block diagram of wireless energy transfer configurations.

FIGS. 2A-2F are exemplary structures and schematics of simple resonator structures.

FIG. 3 is a block diagram of a wireless source with a single-ended amplifier.

FIG. 4 is a block diagram of a wireless source with a differential amplifier.

FIGS. 5A and 5B are block diagrams of sensing circuits.

## 6

FIGS. 6A, 6B, and 6C are block diagrams of a wireless source.

FIG. 7 is a plot showing the effects of a duty cycle on the parameters of an amplifier.

FIG. 8 is a simplified circuit diagram of a wireless power source with a switching amplifier.

FIG. 9 shows plots of the effects of changes of parameters of a wireless power source.

FIG. 10 shows plots of the effects of changes of parameters of a wireless power source.

FIGS. 11A, 11B, and 11C are plots showing the effects of changes of parameters of a wireless power source.

FIG. 12 shows plots of the effects of changes of parameters of a wireless power source.

FIG. 13 is a simplified circuit diagram of a wireless energy transfer system comprising a wireless power source with a switching amplifier and a wireless power device.

FIG. 14 shows plots of the effects of changes of parameters of a wireless power source.

## DETAILED DESCRIPTION

As described above, this disclosure relates to wireless energy transfer using coupled electromagnetic resonators. However, such energy transfer is not restricted to electromagnetic resonators, and the wireless energy transfer systems described herein are more general and may be implemented using a wide variety of resonators and resonant objects.

As those skilled in the art will recognize, important considerations for resonator-based power transfer include resonator efficiency and resonator coupling. Extensive discussion of such issues, e.g., coupled mode theory (CMT), coupling coefficients and factors, quality factors (also referred to as  $Q$ -factors), and impedance matching is provided, for example, in U.S. patent application Ser. No. 12/789,611 published on Sep. 23, 2010 as US 20100237709 and entitled "RESONATOR ARRAYS FOR WIRELESS ENERGY TRANSFER," and U.S. patent application Ser. No. 12/722,050 published on Jul. 22, 2010 as US 20100181843 and entitled "WIRELESS ENERGY TRANSFER FOR REFRIGERATOR APPLICATION" and incorporated herein by reference in its entirety as if fully set forth herein.

A resonator may be defined as a resonant structure that can store energy in at least two different forms, and where the stored energy oscillates between the two forms. The resonant structure will have a specific oscillation mode with a resonant (modal) frequency,  $f$ , and a resonant (modal) field. The angular resonant frequency,  $\omega$ , may be defined as  $\omega=2\pi f$ , the resonant period,  $T$ , may be defined as  $T=1/f=2\pi/\omega$ , and the resonant wavelength,  $\lambda$ , may be defined as  $\lambda=c/f$ , where  $c$  is the speed of the associated field waves (light, for electromagnetic resonators). In the absence of loss mechanisms, coupling mechanisms or external energy supplying or draining mechanisms, the total amount of energy stored by the resonator,  $W$ , would stay fixed, but the form of the energy would oscillate between the two forms supported by the resonator, wherein one form would be maximum when the other is minimum and vice versa.

For example, a resonator may be constructed such that the two forms of stored energy are magnetic energy and electric energy. Further, the resonator may be constructed such that the electric energy stored by the electric field is primarily confined within the structure while the magnetic energy stored by the magnetic field is primarily in the region



surrounding the resonator. In other words, the total electric and magnetic energies would be equal, but their localization would be different. Using such structures, energy exchange between at least two structures may be mediated by the resonant magnetic near-field of the at least two resonators. These types of resonators may be referred to as magnetic resonators.

An important parameter of resonators used in wireless power transmission systems is the Quality Factor, or  $Q$ -factor, or  $Q$ , of the resonator, which characterizes the energy decay and is inversely proportional to energy losses of the resonator. It may be defined as  $Q = \omega * W / P$ , where  $P$  is the time-averaged power lost at steady state. That is, a resonator with a high- $Q$  has relatively low intrinsic losses and can store energy for a relatively long time. Since the resonator loses energy at its intrinsic decay rate,  $2\Gamma$ , its  $Q$ , also referred to as its intrinsic  $Q$ , is given by  $Q = \omega / 2\Gamma$ . The quality factor also represents the number of oscillation periods,  $T$ , it takes for the energy in the resonator to decay by a factor of  $e$ . Note that the quality factor or intrinsic quality factor or  $Q$  of the resonator is that due only to intrinsic loss mechanisms. The  $Q$  of a resonator connected to, or coupled to a power generator,  $g$ , or load,  $l$ , may be called the “loaded quality factor” or the “loaded  $Q$ ”. The  $Q$  of a resonator in the presence of an extraneous object that is not intended to be part of the energy transfer system may be called the “perturbed quality factor” or the “perturbed  $Q$ ”.

Resonators having substantially the same resonant frequency, coupled through any portion of their near-fields may interact and exchange energy. By way of example, but not limitation, imagine a source resonator with  $Q_s$ , and a device resonator with  $Q_d$ . High- $Q$  wireless energy transfer systems may utilize resonators that are high- $Q$ . The  $Q$  of each resonator may be high. The geometric mean of the resonator  $Q$ 's,  $\sqrt{Q_s Q_d}$  may also or instead be high.

The coupling factor,  $k$ , is a number between  $0 \leq k \leq 1$ , and it may be independent (or nearly independent) of the resonant frequencies of the source and device resonators, when those are placed at sub-wavelength distances. Rather the coupling factor  $k$  may be determined mostly by the relative geometry and the distance between the source and device resonators where the physical decay-law of the field mediating their coupling is taken into account. The coupling coefficient used in CMT,  $\kappa = k\sqrt{\omega_s \omega_d} / 2$ , may be a strong function of the resonant frequencies, as well as other properties of the resonator structures. In applications for wireless energy transfer utilizing the near-fields of the resonators, it is desirable to have the size of the resonator be much smaller than the resonant wavelength, so that power lost by radiation is minimized. In some embodiments, high- $Q$  resonators are sub-wavelength structures. In some electromagnetic embodiments, high- $Q$  resonator structures are designed to have resonant frequencies higher than 100 kHz. In other embodiments, the resonant frequencies may be less than 1 GHz.

In exemplary embodiments, the power radiated into the far-field by these sub wavelength resonators may be further reduced by lowering the resonant frequency of the resonators and the operating frequency of the system. In other embodiments, the far field radiation may be reduced by

arranging for the far fields of two or more resonators to interfere destructively in the far field.

In a wireless energy transfer system a resonator may be used as a wireless energy source, a wireless energy capture device, a repeater or a combination thereof. In embodiments a resonator may alternate between transferring energy, receiving energy or relaying energy. In a wireless energy transfer system one or more magnetic resonators may be coupled to an energy source and be energized to produce an oscillating magnetic near-field. Other resonators that are within the oscillating magnetic near-fields may capture these fields and convert the energy into electrical energy that may be used to power or charge a load thereby enabling wireless transfer of useful energy.

The so-called “useful” energy in a useful energy exchange is the energy or power that must be delivered to a device in order to power or charge it at an acceptable rate. The transfer efficiency that corresponds to a useful energy exchange may be system or application-dependent. For example, high power vehicle charging applications that transfer kilowatts of power may need to be at least 80% efficient in order to supply useful amounts of power resulting in a useful energy exchange sufficient to recharge a vehicle battery without significantly heating up various components of the transfer system. In some consumer electronics applications, a useful energy exchange may include any energy transfer efficiencies greater than 10%, or any other amount acceptable to keep rechargeable batteries “topped off” and running for long periods of time. In implanted medical device applications, a useful energy exchange may be any exchange that does not harm the patient but that extends the life of a battery or wakes up a sensor or monitor or stimulator. In such applications, 100 mW of power or less may be useful. In distributed sensing applications, power transfer of microwatts may be useful, and transfer efficiencies may be well below 1%.

A useful energy exchange for wireless energy transfer in a powering or recharging application may be efficient, highly efficient, or efficient enough, as long as the wasted energy levels, heat dissipation, and associated field strengths are within tolerable limits and are balanced appropriately with related factors such as cost, weight, size, and the like.

The resonators may be referred to as source resonators, device resonators, first resonators, second resonators, repeater resonators, and the like. Implementations may include three (3) or more resonators. For example, a single source resonator may transfer energy to multiple device resonators or multiple devices. Energy may be transferred from a first device to a second, and then from the second device to the third, and so forth. Multiple sources may transfer energy to a single device or to multiple devices connected to a single device resonator or to multiple devices connected to multiple device resonators. Resonators may serve alternately or simultaneously as sources, devices, and/or they may be used to relay power from a source in one location to a device in another location. Intermediate electromagnetic resonators may be used to extend the distance range of wireless energy transfer systems and/or to generate areas of concentrated magnetic near-fields. Multiple resonators may be daisy-chained together, exchanging energy over extended distances and with a wide range of sources and devices. For example, a source resonator may transfer power to a device resonator via several repeater resonators. Energy from a source may be transferred to a first repeater resonator, the first repeater resonator may transfer the power to a second repeater resonator and the second to a third and so on until the final repeater resonator transfers its energy to



a device resonator. In this respect the range or distance of wireless energy transfer may be extended and/or tailored by adding repeater resonators. High power levels may be split between multiple sources, transferred to multiple devices and recombined at a distant location.

The resonators may be designed using coupled mode theory models, circuit models, electromagnetic field models, and the like. The resonators may be designed to have tunable characteristic sizes. The resonators may be designed to handle different power levels. In exemplary embodiments, high power resonators may require larger conductors and higher current or voltage rated components than lower power resonators.

FIG. 1 shows a diagram of exemplary configurations and arrangements of a wireless energy transfer system. A wireless energy transfer system may include at least one source resonator (R1) 104 (optionally R6, 112) coupled to an energy source 102 and optionally a sensor and control unit 108. The energy source may be a source of any type of energy capable of being converted into electrical energy that may be used to drive the source resonator 104. The energy source may be a battery, a solar panel, the electrical mains, a wind or water turbine, an electromagnetic resonator, a generator, and the like. The electrical energy used to drive the magnetic resonator is converted into oscillating magnetic fields by the resonator. The oscillating magnetic fields may be captured by other resonators which may be device resonators (R2) 106, (R3) 116 that are optionally coupled to an energy drain 110. The oscillating fields may be optionally coupled to repeater resonators (R4, R5) that are configured to extend or tailor the wireless energy transfer region. Device resonators may capture the magnetic fields in the vicinity of source resonator(s), repeater resonators and other device resonators and convert them into electrical energy that may be used by an energy drain. The energy drain 110 may be an electrical, electronic, mechanical or chemical device and the like configured to receive electrical energy. Repeater resonators may capture magnetic fields in the vicinity of source, device and repeater resonator(s) and may pass the energy on to other resonators.

A wireless energy transfer system may comprise a single source resonator 104 coupled to an energy source 102 and a single device resonator 106 coupled to an energy drain 110. In embodiments a wireless energy transfer system may comprise multiple source resonators coupled to one or more energy sources and may comprise multiple device resonators coupled to one or more energy drains.

In embodiments the energy may be transferred directly between a source resonator 104 and a device resonator 106. In other embodiments the energy may be transferred from one or more source resonators 104, 112 to one or more device resonators 106, 116 via any number of intermediate resonators which may be device resonators, source resonators, repeater resonators, and the like. Energy may be transferred via a network or arrangement of resonators 114 that may include subnetworks 118, 120 arranged in any combination of topologies such as token ring, mesh, ad hoc, and the like.

In embodiments the wireless energy transfer system may comprise a centralized sensing and control system 108. In embodiments parameters of the resonators, energy sources, energy drains, network topologies, operating parameters, etc. may be monitored and adjusted from a control processor to meet specific operating parameters of the system. A central control processor may adjust parameters of individual components of the system to optimize global energy transfer efficiency, to optimize the amount of power trans-

ferred, and the like. Other embodiments may be designed to have a substantially distributed sensing and control system. Sensing and control may be incorporated into each resonator or group of resonators, energy sources, energy drains, and the like and may be configured to adjust the parameters of the individual components in the group to maximize the power delivered, to maximize energy transfer efficiency in that group and the like.

In embodiments, components of the wireless energy transfer system may have wireless or wired data communication links to other components such as devices, sources, repeaters, power sources, resonators, and the like and may transmit or receive data that can be used to enable the distributed or centralized sensing and control. A wireless communication channel may be separate from the wireless energy transfer channel, or it may be the same. In one embodiment the resonators used for power exchange may also be used to exchange information. In some cases, information may be exchanged by modulating a component in a source or device circuit and sensing that change with port parameter or other monitoring equipment. Resonators may signal each other by tuning, changing, varying, dithering, and the like, the resonator parameters such as the impedance of the resonators which may affect the reflected impedance of other resonators in the system. The systems and methods described herein may enable the simultaneous transmission of power and communication signals between resonators in wireless power transmission systems, or it may enable the transmission of power and communication signals during different time periods or at different frequencies using the same magnetic fields that are used during the wireless energy transfer. In other embodiments wireless communication may be enabled with a separate wireless communication channel such as WiFi, Bluetooth, Infrared, and the like.

In embodiments, a wireless energy transfer system may include multiple resonators and overall system performance may be improved by control of various elements in the system. For example, devices with lower power requirements may tune their resonant frequency away from the resonant frequency of a high-power source that supplies power to devices with higher power requirements. In this way, low and high power devices may safely operate or charge from a single high power source. In addition, multiple devices in a charging zone may find the power available to them regulated according to any of a variety of consumption control algorithms such as First-Come-First-Serve, Best Effort, Guaranteed Power, etc. The power consumption algorithms may be hierarchical in nature, giving priority to certain users or types of devices, or it may support any number of users by equally sharing the power that is available in the source. Power may be shared by any of the multiplexing techniques described in this disclosure.

In embodiments electromagnetic resonators may be realized or implemented using a combination of shapes, structures, and configurations. Electromagnetic resonators may include an inductive element, a distributed inductance, or a combination of inductances with a total inductance, L, and a capacitive element, a distributed capacitance, or a combination of capacitances, with a total capacitance, C. A minimal circuit model of an electromagnetic resonator comprising capacitance, inductance and resistance, is shown in FIG. 2F. The resonator may include an inductive element 238 and a capacitive element 240. Provided with initial energy, such as electric field energy stored in the capacitor 240, the system will oscillate as the capacitor discharges transferring energy into magnetic field energy stored in the inductor 238



which in turn transfers energy back into electric field energy stored in the capacitor **240**. Intrinsic losses in these electromagnetic resonators include losses due to resistance in the inductive and capacitive elements and to radiation losses, and are represented by the resistor, R, **242** in FIG. 2F.

FIG. 2A shows a simplified drawing of an exemplary magnetic resonator structure. The magnetic resonator may include a loop of conductor acting as an inductive element **202** and a capacitive element **204** at the ends of the conductor loop. The inductor **202** and capacitor **204** of an electromagnetic resonator may be bulk circuit elements, or the inductance and capacitance may be distributed and may result from the way the conductors are formed, shaped, or positioned, in the structure.

For example, the inductor **202** may be realized by shaping a conductor to enclose a surface area, as shown in FIG. 2A. This type of resonator may be referred to as a capacitively-loaded loop inductor. Note that we may use the terms “loop” or “coil” to indicate generally a conducting structure (wire, tube, strip, etc.), enclosing a surface of any shape and dimension, with any number of turns. In FIG. 2A, the enclosed surface area is circular, but the surface may be any of a wide variety of other shapes and sizes and may be designed to achieve certain system performance specifications. In embodiments the inductance may be realized using inductor elements, distributed inductance, networks, arrays, series and parallel combinations of inductors and inductances, and the like. The inductance may be fixed or variable and may be used to vary impedance matching as well as resonant frequency operating conditions.

There are a variety of ways to realize the capacitance required to achieve the desired resonant frequency for a resonator structure. Capacitor plates **204** may be formed and utilized as shown in FIG. 2A, or the capacitance may be distributed and be realized between adjacent windings of a multi-loop conductor. The capacitance may be realized using capacitor elements, distributed capacitance, networks, arrays, series and parallel combinations of capacitances, and the like. The capacitance may be fixed or variable and may be used to vary impedance matching as well as resonant frequency operating conditions.

The inductive elements used in magnetic resonators may contain more than one loop and may spiral inward or outward or up or down or in some combination of directions. In general, the magnetic resonators may have a variety of shapes, sizes and number of turns and they may be composed of a variety of conducting materials. The conductor **210**, for example, may be a wire, a Litz wire, a ribbon, a pipe, a trace formed from conducting ink, paint, gels, and the like or from single or multiple traces printed on a circuit board. An exemplary embodiment of a trace pattern on a substrate **208** forming inductive loops is depicted in FIG. 2B.

In embodiments the inductive elements may be formed using magnetic materials of any size, shape thickness, and the like, and of materials with a wide range of permeability and loss values. These magnetic materials may be solid blocks, they may enclose hollow volumes, they may be formed from many smaller pieces of magnetic material tiled and or stacked together, and they may be integrated with conducting sheets or enclosures made from highly conducting materials. Conductors may be wrapped around the magnetic materials to generate the magnetic field. These conductors may be wrapped around one or more than one axis of the structure. Multiple conductors may be wrapped around the magnetic materials and combined in parallel, or in series, or via a switch to form customized near-field

patterns and/or to orient the dipole moment of the structure. Examples of resonators comprising magnetic material are depicted in FIGS. 2C, 2D, 2E. In FIG. 2D the resonator comprises loops of conductor **224** wrapped around a core of magnetic material **222** creating a structure that has a magnetic dipole moment **228** that is parallel to the axis of the loops of the conductor **224**. The resonator may comprise multiple loops of conductor **216**, **212** wrapped in orthogonal directions around the magnetic material **214** forming a resonator with a magnetic dipole moment **218**, **220** that may be oriented in more than one direction as depicted in FIG. 2C, depending on how the conductors are driven.

An electromagnetic resonator may have a characteristic, natural, or resonant frequency determined by its physical properties. This resonant frequency is the frequency at which the energy stored by the resonator oscillates between that stored by the electric field,  $W_E$ , ( $W_E=q^2/2C$ , where  $q$  is the charge on the capacitor,  $C$ ) and that stored by the magnetic field,  $W_B$ , ( $W_B=Li^2/2$ , where  $i$  is the current through the inductor,  $L$ ) of the resonator. The frequency at which this energy is exchanged may be called the characteristic frequency, the natural frequency, or the resonant frequency of the resonator, and is given by  $\omega$ ,

$$\omega = 2\pi f = \sqrt{\frac{1}{LC}}.$$

The resonant frequency of the resonator may be changed by tuning the inductance,  $L$ , and/or the capacitance,  $C$ , of the resonator. In one embodiment system parameters are dynamically adjustable or tunable to achieve as close as possible to optimal operating conditions. However, based on the discussion above, efficient enough energy exchange may be realized even if some system parameters are not variable or components are not capable of dynamic adjustment.

In embodiments a resonator may comprise an inductive element coupled to more than one capacitor arranged in a network of capacitors and circuit elements. In embodiments the coupled network of capacitors and circuit elements may be used to define more than one resonant frequency of the resonator. In embodiments a resonator may be resonant, or partially resonant, at more than one frequency.

In embodiments, a wireless power source may comprise of at least one resonator coil coupled to a power supply, which may be a switching amplifier, such as a class-D amplifier or a class-E amplifier or a combination thereof. In this case, the resonator coil is effectively a power load to the power supply. In embodiments, a wireless power device may comprise of at least one resonator coil coupled to a power load, which may be a switching rectifier, such as a class-D rectifier or a class-E rectifier or a combination thereof. In this case, the resonator coil is effectively a power supply for the power load, and the impedance of the load directly relates also to the work-drainage rate of the load from the resonator coil. The efficiency of power transmission between a power supply and a power load may be impacted by how closely matched the output impedance of the power source is to the input impedance of the load. Power may be delivered to the load at a maximum possible efficiency, when the input impedance of the load is equal to the complex conjugate of the internal impedance of the power supply. Designing the power supply or power load impedance to obtain a maximum power transmission efficiency is often called “impedance matching”, and may also referred to as optimizing the ratio of useful-to-lost powers in the system.



Impedance matching may be performed by adding networks or sets of elements such as capacitors, inductors, transformers, switches, resistors, and the like, to form impedance matching networks between a power supply and a power load. In embodiments, mechanical adjustments and changes in element positioning may be used to achieve impedance matching. For varying loads, the impedance matching network may include variable components that are dynamically adjusted to ensure that the impedance at the power supply terminals looking towards the load and the characteristic impedance of the power supply remain substantially complex conjugates of each other, even in dynamic environments and operating scenarios.

In embodiments, impedance matching may be accomplished by tuning the duty cycle, and/or the phase, and/or the frequency of the driving signal of the power supply or by tuning a physical component within the power supply, such as a capacitor. Such a tuning mechanism may be advantageous because it may allow impedance matching between a power supply and a load without the use of a tunable impedance matching network, or with a simplified tunable impedance matching network, such as one that has fewer tunable components for example. In embodiments, tuning the duty cycle, and/or frequency, and/or phase of the driving signal to a power supply may yield a dynamic impedance matching system with an extended tuning range or precision, with higher power, voltage and/or current capabilities, with faster electronic control, with fewer external components, and the like.

In some wireless energy transfer systems the parameters of the resonator such as the inductance may be affected by environmental conditions such as surrounding objects, temperature, orientation, number and position of other resonators and the like. Changes in operating parameters of the resonators may change certain system parameters, such as the efficiency of transferred power in the wireless energy transfer. For example, high-conductivity materials located near a resonator may shift the resonant frequency of a resonator and detune it from other resonant objects. In some embodiments, a resonator feedback mechanism is employed that corrects its frequency by changing a reactive element (e.g., an inductive element or capacitive element). In order to achieve acceptable matching conditions, at least some of the system parameters may need to be dynamically adjustable or tunable. All the system parameters may be dynamically adjustable or tunable to achieve approximately the optimal operating conditions. However, efficient enough energy exchange may be realized even if all or some system parameters are not variable. In some examples, at least some of the devices may not be dynamically adjusted. In some examples, at least some of the sources may not be dynamically adjusted. In some examples, at least some of the intermediate resonators may not be dynamically adjusted. In some examples, none of the system parameters may be dynamically adjusted.

In some embodiments changes in parameters of components may be mitigated by selecting components with characteristics that change in a complimentary or opposite way or direction when subjected to differences in operating environment or operating point. In embodiments, a system may be designed with components, such as capacitors, that have an opposite dependence or parameter fluctuation due to temperature, power levels, frequency, and the like. In some embodiments, the component values as a function of temperature may be stored in a look-up table in a system microcontroller and the reading from a temperature sensor

may be used in the system control feedback loop to adjust other parameters to compensate for the temperature induced component value changes.

In some embodiments the changes in parameter values of components may be compensated with active tuning circuits comprising tunable components. Circuits that monitor the operating environment and operating point of components and system may be integrated in the design. The monitoring circuits may provide the signals necessary to actively compensate for changes in parameters of components. For example, a temperature reading may be used to calculate expected changes in, or to indicate previously measured values of, capacitance of the system allowing compensation by switching in other capacitors or tuning capacitors to maintain the desired capacitance over a range of temperatures. In embodiments, the RF amplifier switching waveforms may be adjusted to compensate for component value or load changes in the system. In some embodiments the changes in parameters of components may be compensated with active cooling, heating, active environment conditioning, and the like.

The parameter measurement circuitry may measure or monitor certain power, voltage, and current, signals in the system, and processors or control circuits may adjust certain settings or operating parameters based on those measurements. In addition the magnitude and phase of voltage and current signals, and the magnitude of the power signals, throughout the system may be accessed to measure or monitor the system performance. The measured signals referred to throughout this disclosure may be any combination of port parameter signals, as well as voltage signals, current signals, power signals, temperatures signals and the like. These parameters may be measured using analog or digital techniques, they may be sampled and processed, and they may be digitized or converted using a number of known analog and digital processing techniques. In embodiments, preset values of certain measured quantities are loaded in a system controller or memory location and used in various feedback and control loops. In embodiments, any combination of measured, monitored, and/or preset signals may be used in feedback circuits or systems to control the operation of the resonators and/or the system.

Adjustment algorithms may be used to adjust the frequency,  $Q$ , and/or impedance of the magnetic resonators. The algorithms may take as inputs reference signals related to the degree of deviation from a desired operating point for the system and may output correction or control signals related to that deviation that control variable or tunable elements of the system to bring the system back towards the desired operating point or points. The reference signals for the magnetic resonators may be acquired while the resonators are exchanging power in a wireless power transmission system, or they may be switched out of the circuit during system operation. Corrections to the system may be applied or performed continuously, periodically, upon a threshold crossing, digitally, using analog methods, and the like.

In embodiments, lossy extraneous materials and objects may introduce potential reductions in efficiencies by absorbing the magnetic and/or electric energy of the resonators of the wireless power transmission system. Those impacts may be mitigated in various embodiments by positioning resonators to minimize the effects of the lossy extraneous materials and objects and by placing structural field shaping elements (e.g., conductive structures, plates and sheets, magnetic material structures, plates and sheets, and combinations thereof) to minimize their effect.



One way to reduce the impact of lossy materials on a resonator is to use high-conductivity materials, magnetic materials, or combinations thereof to shape the resonator fields such that they avoid the lossy objects. In an exemplary embodiment, a layered structure of high-conductivity material and magnetic material may tailor, shape, direct, reorient, etc. the resonator's electromagnetic fields so that they avoid lossy objects in their vicinity by deflecting the fields. FIG. 2D shows a top view of a resonator with a sheet of conductor **226** below the magnetic material that may be used to tailor the fields of the resonator so that they avoid lossy objects that may be below the sheet of conductor **226**. The layer or sheet of good **226** conductor may comprise any high conductivity materials such as copper, silver, aluminum, as may be most appropriate for a given application. In certain embodiments, the layer or sheet of good conductor is thicker than the skin depth of the conductor at the resonator operating frequency. The conductor sheet may be preferably larger than the size of the resonator, extending beyond the physical extent of the resonator.

In environments and systems where the amount of power being transmitted could present a safety hazard to a person or animal that may intrude into the active field volume, safety measures may be included in the system. In embodiments where power levels require particularized safety measures, the packaging, structure, materials, and the like of the resonators may be designed to provide a spacing or "keep away" zone from the conducting loops in the magnetic resonator. To provide further protection, high- $Q$  resonators and power and control circuitry may be located in enclosures that confine high voltages or currents to within the enclosure, that protect the resonators and electrical components from weather, moisture, sand, dust, and other external elements, as well as from impacts, vibrations, scrapes, explosions, and other types of mechanical shock. Such enclosures call for attention to various factors such as thermal dissipation to maintain an acceptable operating temperature range for the electrical components and the resonator. In embodiments, enclosure may be constructed of non-lossy materials such as composites, plastics, wood, concrete, and the like and may be used to provide a minimum distance from lossy objects to the resonator components. A minimum separation distance from lossy objects or environments which may include metal objects, salt water, oil and the like, may improve the efficiency of wireless energy transfer. In embodiments, a "keep away" zone may be used to increase the perturbed  $Q$  of a resonator or system of resonators. In embodiments a minimum separation distance may provide for a more reliable or more constant operating parameters of the resonators.

In embodiments, resonators and their respective sensor and control circuitry may have various levels of integration with other electronic and control systems and subsystems. In some embodiments the power and control circuitry and the device resonators are completely separate modules or enclosures with minimal integration to existing systems, providing a power output and a control and diagnostics interface. In some embodiments a device is configured to house a resonator and circuit assembly in a cavity inside the enclosure, or integrated into the housing or enclosure of the device.

#### Example Resonator Circuitry

FIGS. **3** and **4** show high level block diagrams depicting power generation, monitoring, and control components for exemplary sources of a wireless energy transfer system. FIG. **3** is a block diagram of a source comprising a half-

bridge switching power amplifier and some of the associated measurement, tuning, and control circuitry. FIG. **4** is a block diagram of a source comprising a full-bridge switching amplifier and some of the associated measurement, tuning, and control circuitry.

The half bridge system topology depicted in FIG. **3** may comprise a processing unit that executes a control algorithm **328**. The processing unit executing a control algorithm **328** may be a microcontroller, an application specific circuit, a field programmable gate array, a processor, a digital signal processor, and the like. The processing unit may be a single device or it may be a network of devices. The control algorithm may run on any portion of the processing unit. The algorithm may be customized for certain applications and may comprise a combination of analog and digital circuits and signals. The master algorithm may measure and adjust voltage signals and levels, current signals and levels, signal phases, digital count settings, and the like.

The system may comprise an optional source/device and/or source/other resonator communication controller **332** coupled to wireless communication circuitry **312**. The optional source/device and/or source/other resonator communication controller **332** may be part of the same processing unit that executes the master control algorithm, it may be a part or a circuit within a microcontroller **302**, it may be external to the wireless power transmission modules, it may be substantially similar to communication controllers used in wire powered or battery powered applications but adapted to include some new or different functionality to enhance or support wireless power transmission.

The system may comprise a PWM generator **306** coupled to at least two transistor gate drivers **334** and may be controlled by the control algorithm. The two transistor gate drivers **334** may be coupled directly or via gate drive transformers to two power transistors **336** that drive the source resonator coil **344** through impedance matching network components **342**. The power transistors **336** may be coupled and powered with an adjustable DC supply **304** and the adjustable DC supply **304** may be controlled by a variable bus voltage,  $V_{bus}$ . The  $V_{bus}$  controller may be controlled by the control algorithm **328** and may be part of, or integrated into, a microcontroller **302** or other integrated circuits. The  $V_{bus}$  controller **326** may control the voltage output of an adjustable DC supply **304** which may be used to control power output of the amplifier and power delivered to the resonator coil **344**.

The system may comprise sensing and measurement circuitry including signal filtering and buffering circuits **318**, **320** that may shape, modify, filter, process, buffer, and the like, signals prior to their input to processors and/or converters such as analog to digital converters (ADC) **314**, **316**, for example. The processors and converters such as ADCs **314**, **316** may be integrated into a microcontroller **302** or may be separate circuits that may be coupled to a processing core **330**. Based on measured signals, the control algorithm **328** may generate, limit, initiate, extinguish, control, adjust, or modify the operation of any of the PWM generator **306**, the communication controller **332**, the  $V_{bus}$  control **326**, the source impedance matching controller **338**, the filter/buffering elements, **318**, **320**, the converters, **314**, **316**, the resonator coil **344**, and may be part of, or integrated into, a microcontroller **302** or a separate circuit. The impedance matching networks **342** and resonator coils **344** may include electrically controllable, variable, or tunable components such as capacitors, switches, inductors, and the like, as described herein, and these components may have their component values or operating points adjusted according to



signals received from the source impedance matching controller 338. Components may be tuned to adjust the operation and characteristics of the resonator including the power delivered to and by the resonator, the resonant frequency of the resonator, the impedance of the resonator, the Q of the resonator, and any other coupled systems, and the like. The resonator may be any type or structure resonator described herein including a capacitively loaded loop resonator, a planer resonator comprising a magnetic material or any combination thereof.

The full bridge system topology depicted in FIG. 4 may comprise a processing unit that executes a master control algorithm 328. The processing unit executing the control algorithm 328 may be a microcontroller, an application specific circuit, a field programmable gate array, a processor, a digital signal processor, and the like. The system may comprise a source/device and/or source/other resonator communication controller 332 coupled to wireless communication circuitry 312. The source/device and/or source/other resonator communication controller 332 may be part of the same processing unit that executes that master control algorithm, it may be a part or a circuit within a microcontroller 302, it may be external to the wireless power transmission modules, it may be substantially similar to communication controllers used in wire powered or battery powered applications but adapted to include some new or different functionality to enhance or support wireless power transmission.

The system may comprise a PWM generator 410 with at least two outputs coupled to at least four transistor gate drivers 334 that may be controlled by signals generated in a master control algorithm. The four transistor gate drivers 334 may be coupled to four power transistors 336 directly or via gate drive transformers that may drive the source resonator coil 344 through impedance matching networks 342. The power transistors 336 may be coupled and powered with an adjustable DC supply 304 and the adjustable DC supply 304 may be controlled by a Vbus controller 326 which may be controlled by a master control algorithm. The Vbus controller 326 may control the voltage output of the adjustable DC supply 304 which may be used to control power output of the amplifier and power delivered to the resonator coil 344.

The system may comprise sensing and measurement circuitry including signal filtering and buffering circuits 318, 320 and differential/single ended conversion circuitry 402, 404 that may shape, modify, filter, process, buffer, and the like, signals prior to being input to processors and/or converters such as analog to digital converters (ADC) 314, 316. The processors and/or converters such as ADC 314, 316 may be integrated into a microcontroller 302 or may be separate circuits that may be coupled to a processing core 330. Based on measured signals, the master control algorithm may generate, limit, initiate, extinguish, control, adjust, or modify the operation of any of the PWM generator 410, the communication controller 332, the Vbus controller 326, the source impedance matching controller 338, the filter/buffering elements, 318, 320, differential/single ended conversion circuitry 402, 404, the converters, 314, 316, the resonator coil 344, and may be part of or integrated into a microcontroller 302 or a separate circuit.

Impedance matching networks 342 and resonator coils 344 may comprise electrically controllable, variable, or tunable components such as capacitors, switches, inductors, and the like, as described herein, and these components may have their component values or operating points adjusted according to signals received from the source impedance matching controller 338. Components may be tuned to

enable tuning of the operation and characteristics of the resonator including the power delivered to and by the resonator, the resonant frequency of the resonator, the impedance of the resonator, the Q of the resonator, and any other coupled systems, and the like. The resonator may be any type or structure resonator described herein including a capacitively loaded loop resonator, a planar resonator comprising a magnetic material or any combination thereof.

Impedance matching networks may comprise fixed value components such as capacitors, inductors, and networks of components as described herein. Parts of the impedance matching networks, A, B and C, may comprise inductors, capacitors, transformers, and series and parallel combinations of such components, as described herein. In some embodiments, parts of the impedance matching networks A, B, and C, may be empty (short-circuited). In some embodiments, part B comprises a series combination of an inductor and a capacitor, and part C is empty.

The full bridge topology may allow operation at higher output power levels using the same DC bus voltage as an equivalent half bridge amplifier. The half bridge exemplary topology of FIG. 3 may provide a single-ended drive signal, while the exemplary full bridge topology of FIG. 4 may provide a differential drive to the source resonator 308. The impedance matching topologies and components and the resonator structure may be different for the two systems, as discussed herein.

The exemplary systems depicted in FIGS. 3 and 4 may further include fault detection circuitry 340 that may be used to trigger the shutdown of the microcontroller in the source amplifier or to change or interrupt the operation of the amplifier. This protection circuitry may comprise a high speed comparator or comparators to monitor the amplifier return current, the amplifier bus voltage (Vbus) from the DC supply 304, the voltage across the source resonator 308 and/or the optional tuning board, or any other voltage or current signals that may cause damage to components in the system or may yield undesirable operating conditions. Preferred embodiments may depend on the potentially undesirable operating modes associated with different applications. In some embodiments, protection circuitry may not be implemented or circuits may not be populated. In some embodiments, system and component protection may be implemented as part of a master control algorithm and other system monitoring and control circuits. In embodiments, dedicated fault circuitry 340 may include an output (not shown) coupled to a master control algorithm 328 that may trigger a system shutdown, a reduction of the output power (e.g. reduction of Vbus), a change to the PWM generator, a change in the operating frequency, a change to a tuning element, or any other reasonable action that may be implemented by the control algorithm 328 to adjust the operating point mode, improve system performance, and/or provide protection.

As described herein, sources in wireless power transfer systems may use a measurement of the input impedance of the impedance matching network 342 driving source resonator coil 344 as an error or control signal for a system control loop that may be part of the master control algorithm. In exemplary embodiments, variations in any combination of three parameters may be used to tune the wireless power source to compensate for changes in environmental conditions, for changes in coupling, for changes in device power demand, for changes in module, circuit, component or subsystem performance, for an increase or decrease in the number or sources, devices, or repeaters in the system, for user initiated changes, and the like. In exemplary embodi-



ments, changes to the amplifier duty cycle, to the component values of the variable electrical components such as variable capacitors and inductors, and to the DC bus voltage may be used to change the operating point or operating range of the wireless source and improve some system operating value. The specifics of the control algorithms employed for different applications may vary depending on the desired system performance and behavior.

Impedance measurement circuitry such as described herein, and shown in FIGS. 3 and 4, may be implemented using two-channel simultaneous sampling ADCs and these ADCs may be integrated into a microcontroller chip or may be part of a separate circuit. Simultaneously sampling of the voltage and current signals at the input to a source resonator's impedance matching network and/or the source resonator, may yield the phase and magnitude information of the current and voltage signals and may be processed using known signal processing techniques to yield complex impedance parameters. In some embodiments, monitoring only the voltage signals or only the current signals may be sufficient.

The impedance measurements described herein may use direct sampling methods which may be relatively simpler than some other known sampling methods. In embodiments, measured voltage and current signals may be conditioned, filtered and scaled by filtering/buffering circuitry before being input to ADCs. In embodiments, the filter/buffering circuitry may be adjustable to work at a variety of signal levels and frequencies, and circuit parameters such as filter shapes and widths may be adjusted manually, electronically, automatically, in response to a control signal, by the master control algorithm, and the like. Exemplary embodiments of filter/buffering circuits are shown in FIGS. 3, 4, and 5.

FIG. 5 shows more detailed views of exemplary circuit components that may be used in filter/buffering circuitry. In embodiments, and depending on the types of ADCs used in the system designs, single-ended amplifier topologies may reduce the complexity of the analog signal measurement paths used to characterize system, subsystem, module and/or component performance by eliminating the need for hardware to convert from differential to single-ended signal formats. In other implementations, differential signal formats may be preferable. The implementations shown in FIG. 5 are exemplary, and should not be construed to be the only possible way to implement the functionality described herein. Rather it should be understood that the analog signal path may employ components with different input requirements and hence may have different signal path architectures.

In both the single ended and differential amplifier topologies, the input current to the impedance matching networks 342 driving the resonator coils 344 may be obtained by measuring the voltage across a capacitor 324, or via a current sensor of some type. For the exemplary single-ended amplifier topology in FIG. 3, the current may be sensed on the ground return path from the impedance matching network 342. For the exemplary differential power amplifier depicted in FIG. 4, the input current to the impedance matching networks 342 driving the resonator coils 344 may be measured using a differential amplifier across the terminals of a capacitor 324 or via a current sensor of some type. In the differential topology of FIG. 4, the capacitor 324 may be duplicated at the negative output terminal of the source power amplifier.

In both topologies, after single ended signals representing the input voltage and current to the source resonator and impedance matching network are obtained, the signals may

be filtered 502 to obtain the desired portions of the signal waveforms. In embodiments, the signals may be filtered to obtain the fundamental component of the signals. In embodiments, the type of filtering performed, such as low pass, bandpass, notch, and the like, as well as the filter topology used, such as elliptical, Chebyshev, Butterworth, and the like, may depend on the specific requirements of the system. In some embodiments, no filtering will be required.

The voltage and current signals may be amplified by an optional amplifier 504. The gain of the optional amplifier 504 may be fixed or variable. The gain of the amplifier may be controlled manually, electronically, automatically, in response to a control signal, and the like. The gain of the amplifier may be adjusted in a feedback loop, in response to a control algorithm, by the master control algorithm, and the like. In embodiments, required performance specifications for the amplifier may depend on signal strength and desired measurement accuracy, and may be different for different application scenarios and control algorithms.

The measured analog signals may have a DC offset added to them, 506, which may be required to bring the signals into the input voltage range of the ADC which for some systems may be 0 to 3.3V. In some systems this stage may not be required, depending on the specifications of the particular ADC used.

As described above, the efficiency of power transmission between a power generator and a power load may be impacted by how closely matched the output impedance of the generator is to the input impedance of the load. In an exemplary system as shown in FIG. 6A, power may be delivered to the load at a maximum possible efficiency, when the input impedance of the load 604 is equal to the complex conjugate of the internal impedance of the power generator or the power amplifier 602. Designing the generator or load impedance to obtain a high and/or maximum power transmission efficiency may be called "impedance matching". Impedance matching may be performed by inserting appropriate networks or sets of elements such as capacitors, resistors, inductors, transformers, switches and the like, to form an impedance matching network 606, between a power generator 602 and a power load 604 as shown in FIG. 6B. In other embodiments, mechanical adjustments and changes in element positioning may be used to achieve impedance matching. As described above for varying loads, the impedance matching network 606 may include variable components that are dynamically adjusted to ensure that the impedance at the generator terminals looking towards the load and the characteristic impedance of the generator remain substantially complex conjugates of each other, even in dynamic environments and operating scenarios. In embodiments, dynamic impedance matching may be accomplished by tuning the duty cycle, and/or the phase, and/or the frequency of the driving signal of the power generator or by tuning a physical component within the power generator, such as a capacitor, as depicted in FIG. 6C. Such a tuning mechanism may be advantageous because it may allow impedance matching between a power generator 608 and a load without the use of a tunable impedance matching network, or with a simplified tunable impedance matching network 606, such as one that has fewer tunable components for example. In embodiments, tuning the duty cycle, and/or frequency, and/or phase of the driving signal to a power generator may yield a dynamic impedance matching system with an extended tuning range or precision, with higher power, voltage and/or current capabilities, with faster electronic control, with fewer external components, and the like. The impedance matching methods, architectures, algo-



rithms, protocols, circuits, measurements, controls, and the like, described below, may be useful in systems where power generators drive high-Q magnetic resonators and in high-Q wireless power transmission systems as described herein. In wireless power transfer systems a power generator may be a power amplifier driving a resonator, sometimes referred to as a source resonator, which may be a load to the power amplifier. In wireless power applications, it may be preferable to control the impedance matching between a power amplifier and a resonator load to control the efficiency of the power delivery from the power amplifier to the resonator. The impedance matching may be accomplished, or accomplished in part, by tuning or adjusting the duty cycle, and/or the phase, and/or the frequency of the driving signal of the power amplifier that drives the resonator.

#### Efficiency of Switching Amplifiers

Switching amplifiers, such as class D, E, F amplifiers, and the like or any combinations thereof, deliver power to a load at a maximum efficiency when no power is dissipated on the switching elements of the amplifier. This operating condition may be accomplished by designing the system so that the switching operations which are most critical (namely those that are most likely to lead to switching losses) are done when both the voltage across the switching element and the current through the switching element are zero. These conditions may be referred to as Zero Voltage Switching (ZVS) and Zero Current Switching (ZCS) conditions respectively. When an amplifier operates at ZVS and ZCS either the voltage across the switching element or the current through the switching element is zero and thus no power can be dissipated in the switch. Since a switching amplifier may convert DC (or very low frequency AC) power to AC power at a specific frequency or range of frequencies, a filter may be introduced before the load to prevent unwanted harmonics that may be generated by the switching process from reaching the load and being dissipated there. In embodiments, a switching amplifier may be designed to operate at maximum efficiency of power conversion, when connected to a resonant load, with a nontrivial quality factor (say  $Q > 5$ ), and of a specific impedance  $Z_o^* = R_o + jX_o$ , which leads to simultaneous ZVS and ZCS. We define  $Z_o = R_o - jX_o$  as the characteristic impedance of the amplifier, so that achieving maximum power transmission efficiency is equivalent to impedance matching the resonant load to the characteristic impedance of the amplifier.

In a switching amplifier, the switching frequency of the switching elements,  $f_{switch}$ , wherein  $f_{switch} = \omega / 2\pi$  and the duty cycle,  $dc$ , of the ON switch-state duration of the switching elements may be the same for all switching elements of the amplifier. In this specification, we will use the term “class D” to denote both class D and class DE amplifiers, that is, switching amplifiers with  $dc \leq 50\%$ .

The value of the characteristic impedance of the amplifier may depend on the operating frequency, the amplifier topology, and the switching sequence of the switching elements. In some embodiments, the switching amplifier may be a half-bridge topology and, in some embodiments, a full-bridge topology. In some embodiments, the switching amplifier may be class D and, in some embodiments, class E. In any of the above embodiments, assuming the elements of the bridge are symmetric, the characteristic impedance of the switching amplifier has the form

$$R_o = F_R(dc) / \omega C_a, X_o = F_X(dc) / \omega C_a, \quad (1)$$

where  $dc$  is the duty cycle of ON switch-state of the switching elements, the functions  $F_R(dc)$  and  $F_X(dc)$  are plotted in FIG. 7 (both for class D and E),  $\omega$  is the frequency

at which the switching elements are switched, and  $C_a = n_a C_{switch}$  where  $C_{switch}$  is the capacitance across each switch, including both the transistor output capacitance and also possible external capacitors placed in parallel with the switch, while  $n_a = 1$  for a full bridge and  $n_a = 2$  for a half bridge. For class D, one can also write the analytical expressions

$$F_R(dc) = \sin^2 u / \pi, F_X(dc) = (u - \sin u \cos u) / \pi, \quad (2)$$

where  $u = \pi(1 - 2dc)$ , indicating that the characteristic impedance level of a class D amplifier decreases as the duty cycle,  $dc$ , increases towards 50%. For a class D amplifier operation with  $dc = 50\%$ , achieving ZVS and ZCS is possible only when the switching elements have practically no output capacitance ( $C_a = 0$ ) and the load is exactly on resonance ( $X_o = 0$ ), while  $R_o$  can be arbitrary.

#### Impedance Matching Networks

In applications, the driven load may have impedance that is very different from the characteristic impedance of the external driving circuit, to which it is connected. Furthermore, the driven load may not be a resonant network. An Impedance Matching Network (IMN) is a circuit network that may be connected before a load as in FIG. 6B, in order to regulate the impedance that is seen at the input of the network consisting of the IMN circuit and the load. An IMN circuit may typically achieve this regulation by creating a resonance close to the driving frequency. Since such an IMN circuit accomplishes all conditions needed to maximize the power transmission efficiency from the generator to the load (resonance and impedance matching—ZVS and ZCS for a switching amplifier), in embodiments, an IMN circuit may be used between the driving circuit and the load.

For an arrangement shown in FIG. 6B, let the input impedance of the network consisting of the Impedance Matching Network (IMN) circuit and the load (denoted together from now on as IMN+load) be  $Z_l = R_l(\omega) + jX_l(\omega)$ . The impedance matching conditions of this network to the external circuit with characteristic impedance  $Z_o = R_o - jX_o$  are then  $R_l(\omega) = R_o$ ,  $X_l(\omega) = X_o$ .

#### Methods for Tunable Impedance Matching of a Variable Load

In embodiments where the load may be variable, impedance matching between the load and the external driving circuit, such as a linear or switching power amplifier, may be achieved by using adjustable/tunable components in the IMN circuit that may be adjusted to match the varying load to the fixed characteristic impedance  $Z_o$  of the external circuit (FIG. 6B). To match both the real and imaginary parts of the impedance two tunable/variable elements in the IMN circuit may be needed.

In embodiments, the load may be inductive (such as a resonator coil) with impedance  $R + j\omega L$ , so the two tunable elements in the IMN circuit may be two tunable capacitance networks or one tunable capacitance network and one tunable inductance network or one tunable capacitance network and one tunable mutual inductance network.

In embodiments where the load may be variable, the impedance matching between the load and the driving circuit, such as a linear or switching power amplifier, may be achieved by using adjustable/tunable components or parameters in the amplifier circuit that may be adjusted to match the characteristic impedance  $Z_o$  of the amplifier to the varying (due to load variations) input impedance of the network consisting of the IMN circuit and the load (IMN+load), where the IMN circuit may also be tunable (FIG. 6C). To match both the real and imaginary parts of the impedance, a total of two tunable/variable elements or parameters



in the amplifier and the IMN circuit may be needed. The disclosed impedance matching method can reduce the required number of tunable/variable elements in the IMN circuit or even completely eliminate the requirement for tunable/variable elements in the IMN circuit. In some examples, one tunable element in the power amplifier and one tunable element in the IMN circuit may be used. In some examples, two tunable elements in the power amplifier and no tunable element in the IMN circuit may be used.

In embodiments, the tunable elements or parameters in the power amplifier may be the frequency, amplitude, phase, waveform, duty cycle and the like of the drive signals applied to transistors, switches, diodes and the like.

In embodiments, the power amplifier with tunable characteristic impedance may be a tunable switching amplifier of class D, E, F or any combinations thereof. Combining Equations (1) and (2), the impedance matching conditions for this network are

$$R_I(\omega) = F_R(dc)/\omega C_a, X_I(\omega) = F_X(dc)/\omega C_a \quad (3).$$

In some examples of a tunable switching amplifier, one tunable element may be the capacitance  $C_a$ , which may be tuned by tuning the external capacitors placed in parallel with the switching elements.

In some examples of a tunable switching amplifier, one tunable element may be the duty cycle  $dc$  of the ON switch-state of the switching elements of the amplifier. Adjusting the duty cycle,  $dc$ , via Pulse Width Modulation (PWM) has been used in switching amplifiers to achieve output power control. In this specification, we disclose that PWM may also be used to achieve impedance matching, namely to satisfy Eqs. (3), and thus maximize the amplifier efficiency.

In some examples of a tunable switching amplifier one tunable element may be the switching frequency, which is also the driving frequency of the IMN+load network and may be designed to be substantially close to the resonant frequency of the IMN+load network. Tuning the switching frequency may change the characteristic impedance of the amplifier and the impedance of the IMN+load network. The switching frequency of the amplifier may be tuned appropriately together with one more tunable parameters, so that Eqs.(3) are satisfied.

A benefit of tuning the duty cycle and/or the driving frequency of the amplifier for dynamic impedance matching is that these parameters can be tuned electronically, quickly, and over a broad range. In contrast, for example, a tunable capacitor that can sustain a large voltage and has a large enough tunable range and quality factor may be expensive, slow or unavailable for with the necessary component specifications

Examples of Methods for Tunable Impedance Matching of a Variable Load

A simplified circuit diagram showing the circuit level structure of a class D power amplifier **802**, impedance matching network **804** and an inductive load **806** is shown in FIG. **8**. The diagram shows the basic components of the system with the switching amplifier **804** comprising a power source **810**, switching elements **808**, and capacitors. The impedance matching network **804** comprising inductors and capacitors, and the load **806** modeled as an inductor and a resistor.

An exemplary embodiment of this inventive tuning scheme comprises a half-bridge class-D amplifier operating at switching frequency  $f$  and driving a low-loss inductive element  $R+j\omega L$  via an IMN, as shown in FIG. **8**.

In some embodiments  $L'$  may be tunable.  $L'$  may be tuned by a variable tapping point on the inductor or by connecting a tunable capacitor in series or in parallel to the inductor. In some embodiments  $C_a$  may be tunable. For the half bridge topology,  $C_a$  may be tuned by varying either one or both capacitors  $C_{switch}$ , as only the parallel sum of these capacitors matters for the amplifier operation. For the full bridge topology,  $C_a$  may be tuned by varying either one, two, three or all capacitors  $C_{switch}$ , as only their combination (series sum of the two parallel sums associated with the two halves of the bridge) matters for the amplifier operation.

In some embodiments of tunable impedance matching, two of the components of the IMN may be tunable. In some embodiments,  $L'$  and  $C_2$  may be tuned. Then, FIG. **9** shows the values of the two tunable components needed to achieve impedance matching as functions of the varying  $R$  and  $L$  of the inductive element, and the associated variation of the output power (at given DC bus voltage) of the amplifier, for  $f=250$  kHz,  $dc=40\%$ ,  $C_a=640$  pF and  $C_1=10$  nF. Since the IMN always adjusts to the fixed characteristic impedance of the amplifier, the output power is always constant as the inductive element is varying.

In some embodiments of tunable impedance matching, elements in the switching amplifier may also be tunable. In some embodiments the capacitance  $C_a$  along with the IMN capacitor  $C_2$  may be tuned. Then, FIG. **10** shows the values of the two tunable components needed to achieve impedance matching as functions of the varying  $R$  and  $L$  of the inductive element, and the associated variation of the output power (at given DC bus voltage) of the amplifier for  $f=250$  kHz,  $dc=40\%$ ,  $C_1=10$  nF and  $\omega L'=1000\Omega$ . It can be inferred from FIG. **10** that  $C_2$  needs to be tuned mainly in response to variations in  $L$  and that the output power decreases as  $R$  increases.

In some embodiments of tunable impedance matching, the duty cycle  $dc$  along with the IMN capacitor  $C_2$  may be tuned. Then, FIG. **11** shows the values of the two tunable parameters needed to achieve impedance matching as functions of the varying  $R$  and  $L$  of the inductive element, and the associated variation of the output power (at given DC bus voltage) of the amplifier for  $f=250$  kHz,  $C_a=640$  pF,  $C_1=10$  nF and  $\omega L'=1000\Omega$ . It can be inferred from FIG. **11** that  $C_2$  needs to be tuned mainly in response to variations in  $L$  and that the output power decreases as  $R$  increases.

In some embodiments of tunable impedance matching, the capacitance  $C_a$  along with the IMN inductor  $L'$  may be tuned. Then, FIG. **11A** shows the values of the two tunable components needed to achieve impedance matching as functions of the varying  $R$  of the inductive element, and the associated variation of the output power (at given DC bus voltage) of the amplifier for  $f=250$  kHz,  $dc=40\%$ ,  $C_1=10$  nF and  $C_2=7.5$  nF. It can be inferred from FIG. **11A** that the output power decreases as  $R$  increases.

In some embodiments of tunable impedance matching, the duty cycle  $dc$  along with the IMN inductor  $L'$  may be tuned. Then, FIG. **11B** shows the values of the two tunable parameters needed to achieve impedance matching as functions of the varying  $R$  of the inductive element, and the associated variation of the output power (at given DC bus voltage) of the amplifier for  $f=250$  kHz,  $C_a=640$  pF,  $C_1=10$  nF and  $C_2=7.5$  nF as functions of the varying  $R$  of the inductive element. It can be inferred from FIG. **11B** that the output power decreases as  $R$  increases.

In some embodiments of tunable impedance matching, only elements in the switching amplifier may be tunable with no tunable elements in the IMN. In some embodiments the duty cycle  $dc$  along with the capacitance  $C_a$  may be



tuned. Then, FIG. 11C, shows the values of the two tunable parameters needed to achieve impedance matching as functions of the varying  $R$  of the inductive element, and the associated variation of the output power (at given DC bus voltage) of the amplifier for  $f=250$  kHz,  $C_1=10$  nF,  $C_2=7.5$  nF and  $\omega L'=1000\Omega$ . It can be inferred from FIG. 11C that the output power is a non-monotonic function of  $R$ . These embodiments may be able to achieve dynamic impedance matching when variations in  $L$  (and thus the resonant frequency) are modest.

In some embodiments, dynamic impedance matching with fixed elements inside the IMN, also when  $L$  is varying greatly as explained earlier, may be achieved by varying the driving frequency of the external frequency  $f$  (e.g. the switching frequency of a switching amplifier) so that it follows the varying resonant frequency of the resonator. Using the switching frequency  $f$  and the switch duty cycle  $dc$  as the two variable parameters, full impedance matching can be achieved as  $R$  and  $L$  are varying without the need of any variable components. Then, FIG. 12 shows the values of the two tunable parameters needed to achieve impedance matching as functions of the varying  $R$  and  $L$  of the inductive element, and the associated variation of the output power (at given DC bus voltage) of the amplifier for  $C_a=640$  pF,  $C_1=10$  nF,  $C_2=7.5$  nF and  $L'=637$   $\mu$ H. It can be inferred from FIG. 12 that the frequency  $f$  needs to be tuned mainly in response to variations in  $L$ , as explained earlier.

#### Tunable Impedance Matching for Systems of Wireless Power Transmission

In applications of wireless power transfer the low-loss inductive element may be the coil of a source resonator coupled to one or more device resonators or other resonators, such as repeater resonators, for example. The impedance of the inductive element  $R+j\omega L$  may include the reflected impedances of the other resonators on the coil of the source resonator. Variations of  $R$  and  $L$  of the inductive element may occur due to external perturbations in the vicinity of the source resonator and/or the other resonators or thermal drift of components. Variations of  $R$  and  $L$  of the inductive element may also occur during normal use of the wireless power transmission system due to relative motion of the devices and other resonators with respect to the source. The relative motion of these devices and other resonators with respect to the source, or relative motion or position of other sources, may lead to varying coupling (and thus varying reflected impedances) of the devices to the source. Furthermore, variations of  $R$  and  $L$  of the inductive element may also occur during normal use of the wireless power transmission system due to changes within the other coupled resonators, such as changes in the power draw of their loads. All the methods and embodiments disclosed so far apply also to this case in order to achieve dynamic impedance matching of this inductive element to the external circuit driving it.

To demonstrate the presently disclosed dynamic impedance matching methods for a wireless power transmission system, consider a source resonator including a low-loss source coil, which is inductively coupled to the device coil of a device resonator driving a resistive load.

In some embodiments, dynamic impedance matching may be achieved at the source circuit. In some embodiments, dynamic impedance matching may also be achieved at the device circuit. When full impedance matching is obtained (both at the source and the device), the effective resistance of the source inductive element (namely the resistance of the source coil  $R_s$  plus the reflected impedance from the device)

is  $R=R_s\sqrt{1+U_{sd}^2}$ . (Similarly the effective resistance of the device inductive element is  $R_d\sqrt{1+U_{sd}^2}$ , where  $R_d$  is the resistance of the device coil.) Dynamic variation of the mutual inductance between the coils due to motion results in a dynamic variation of  $U_{sd}=\omega M_{sd}/\sqrt{R_s R_d}$ . Therefore, when both source and device are dynamically tuned, the variation of mutual inductance is seen from the source circuit side as a variation in the source inductive element resistance  $R$ . Note that in this type of variation, the resonant frequencies of the resonators may not change substantially, since  $L$  may not be changing. Therefore, all the methods and examples presented for dynamic impedance matching may be used for the source circuit of the wireless power transmission system.

Note that, since the resistance  $R$  represents both the source coil and the reflected impedances of the device coils to the source coil, in FIGS. 9-12, as  $R$  increases due to the increasing  $U$ , the associated wireless power transmission efficiency increases. In some embodiments, an approximately constant power may be required at the load driven by the device circuitry. To achieve a constant level of power transmitted to the device, the required output power of the source circuit may need to decrease as  $U$  increases. If dynamic impedance matching is achieved via tuning some of the amplifier parameters, the output power of the amplifier may vary accordingly. In some embodiments, the automatic variation of the output power is preferred to be monotonically decreasing with  $R$ , so that it matches the constant device power requirement. In embodiments where the output power level is accomplished by adjusting the DC driving voltage of the power generator, using an impedance matching set of tunable parameters which leads to monotonically decreasing output power vs.  $R$  will imply that constant power can be kept at the power load in the device with only a moderate adjustment of the DC driving voltage. In embodiments, where the “knob” to adjust the output power level is the duty cycle  $dc$  or the phase of a switching amplifier or a component inside an Impedance Matching Network, using an impedance matching set of tunable parameters which leads to monotonically decreasing output power vs.  $R$  will imply that constant power can be kept at the power load in the device with only a moderate adjustment of this power “knob”.

In the examples of FIGS. 9-12, if  $R_s=0.19\Omega$ , then the range  $R=0.2-2\Omega$  corresponds approximately to  $U_{sd}=0.3-10.5$ . For these values, in FIG. 14, we show with dashed lines the output power (normalized to DC voltage squared) required to keep a constant power level at the load, when both source and device are dynamically impedance matched. The similar trend between the solid and dashed lines explains why a set of tunable parameters with such a variation of output power may be preferable.

In some embodiments, dynamic impedance matching may be achieved at the source circuit, but impedance matching may not be achieved or may only partially be achieved at the device circuit. As the mutual inductance between the source and device coils varies, the varying reflected impedance of the device to the source may result in a variation of both the effective resistance  $R$  and the effective inductance  $L$  of the source inductive element. The methods presented so far for dynamic impedance matching are applicable and can be used for the tunable source circuit of the wireless power transmission system.

As an example, consider the circuit of FIG. 14, where  $f=250$  kHz,  $C_a=640$  pF,  $R_s=0.19\Omega$ ,  $L_s=100$   $\mu$ H,  $C_{1s}=10$  nF,  $\omega L'_s=1000\Omega$ ,  $R_d=0.3\Omega$ ,  $L_d=40$   $\mu$ H,  $C_{1d}=87.5$  nF,  $C_{2d}=13$  nF,  $\omega L'_d=400\Omega$  and  $Z_1=50\Omega$ , where  $s$  and  $d$  denote the source



and device resonators respectively and the system is matched at  $U_{sd}=3$ . Tuning the duty cycle  $dc$  of the switching amplifier and the capacitor  $C_{2s}$  may be used to dynamically impedance match the source, as the non-tunable device is moving relatively to the source changing the mutual inductance  $M$  between the source and the device. In FIG. 14, we show the required values of the tunable parameters along with the output power per DC voltage of the amplifier. The dashed line again indicates the output power of the amplifier that would be needed so that the power at the load is a constant value.

In some embodiments, tuning the driving frequency  $f$  of the source driving circuit may still be used to achieve dynamic impedance matching at the source for a system of wireless power transmission between the source and one or more devices. As explained earlier, this method enables full dynamic impedance matching of the source, even when there are variations in the source inductance  $L_s$  and thus the source resonant frequency. For efficient power transmission from the source to the devices, the device resonant frequencies must be tuned to follow the variations of the matched driving and source-resonant frequencies. Tuning a device capacitance (for example, in the embodiment of FIG. 13  $C_{1d}$  or  $C_{2d}$ ) may be necessary, when there are variations in the resonant frequency of either the source or the device resonators. In fact, in a wireless power transfer system with multiple sources and devices, tuning the driving frequency alleviates the need to tune only one source-object resonant frequency, however, all the rest of the objects may need a mechanism (such as a tunable capacitance) to tune their resonant frequencies to match the driving frequency.

While the invention has been described in connection with certain preferred embodiments, other embodiments will be understood by one of ordinary skill in the art and are intended to fall within the scope of this disclosure, which is to be interpreted in the broadest sense allowable by law.

All documents referenced herein are hereby incorporated by reference in their entirety as if fully set forth herein.

What is claimed is:

1. A source for a wireless power transfer system comprising:

sensing and measurement circuitry configured to process signals associated with a source resonator and a source impedance matching network comprising one or more tunable components;

a PWM (pulse width modulation) generator coupled with at least two power transistors of an amplifier coupled with the source impedance matching network, wherein the PWM generator is configured to control a driving signal to drive the source resonator using the at least two power transistors; and

a controller coupled with the sensing and measurement circuitry to receive measured signals from the sensing and measurement circuitry, wherein the controller is configured to control a component value or an operating point of at least one of the one or more tunable components, and the controller is configured to modify operation of the PWM generator based on the measured signals to modify at least a phase of the driving signal while changing power delivered to the source resonator.

2. The source for a wireless power transfer system of claim 1, wherein the controller is configured to modify operation of the source impedance matching network based on the measured signals.

3. The source for a wireless power transfer system of claim 2, wherein the controller is configured to modify at

least one of a duty cycle or the phase of the driving signal based on the measured signals to yield dynamic source impedance matching with an extended tuning range or precision.

4. The source for a wireless power transfer system of claim 3, wherein the controller comprises a communication controller and a source impedance matching controller integrated into a microcontroller.

5. The source for a wireless power transfer system of claim 2, wherein the controller is configured to adjust a resonant frequency of the source resonator.

6. The source for a wireless power transfer system of claim 2, wherein the amplifier comprises a half-bridge switching power amplifier comprising the at least two power transistors.

7. The source for a wireless power transfer system of claim 2, wherein the amplifier comprises a full-bridge switching power amplifier comprising the at least two power transistors.

8. The source for a wireless power transfer system of claim 2, wherein the amplifier is a class-D or class-E switching amplifier.

9. The source for a wireless power transfer system of claim 1, wherein the sensing and measurement circuitry includes signal filtering and buffering circuits, and the sensing and measurement circuitry includes differential or single-ended conversion circuitry.

10. The source for a wireless power transfer system of claim 1, wherein the sensing and measurement circuitry is coupled with an analog-to-digital converter (ADC).

11. The source for a wireless power transfer system of claim 1, wherein the measured signals comprise one or more of port parameter signals, voltage signals, current signals, power signals, or temperatures signals.

12. The source for a wireless power transfer system of claim 1, comprising an integrated circuit chip comprising the controller.

13. The source for a wireless power transfer system of claim 1, wherein the controller is configured to control a voltage output of an adjustable DC supply coupled with the amplifier.

14. The source for a wireless power transfer system of claim 13, comprising a Vbus controller through which the voltage output of the adjustable DC supply is controlled.

15. The source for a wireless power transfer system of claim 14, wherein the controller and the Vbus controller are integrated into a microcontroller.

16. The source for a wireless power transfer system of claim 13, wherein the controller is configured to maintain a zero voltage switching condition at the amplifier.

17. The source for a wireless power transfer system of claim 13, wherein the controller is configured to maintain a zero current switching condition at the amplifier.

18. The source for a wireless power transfer system of claim 1, comprising fault detection circuitry configured to change or interrupt operation of the amplifier.

19. The source for a wireless power transfer system of claim 18, wherein the fault detection circuitry comprises one or more comparators to monitor voltage or current signals.

20. The source for a wireless power transfer system of claim 19, wherein the comparators monitor bus voltage.

21. The source for a wireless power transfer system of claim 18, wherein the fault detection circuitry has an output to cause a change to the PWM generator, a shutdown, or a reduction of output power.



UNITED STATES PATENT AND TRADEMARK OFFICE  
**CERTIFICATE OF CORRECTION**

PATENT NO. : 10,673,282 B2  
APPLICATION NO. : 16/246764  
DATED : June 2, 2020  
INVENTOR(S) : Andrew J. Campanella et al.

Page 1 of 1

It is certified that error appears in the above-identified patent and that said Letters Patent is hereby corrected as shown below:

In the Specification

Column 1

Line 39 (Approx.), after "application" insert -- is --

Signed and Sealed this  
Fourteenth Day of July, 2020

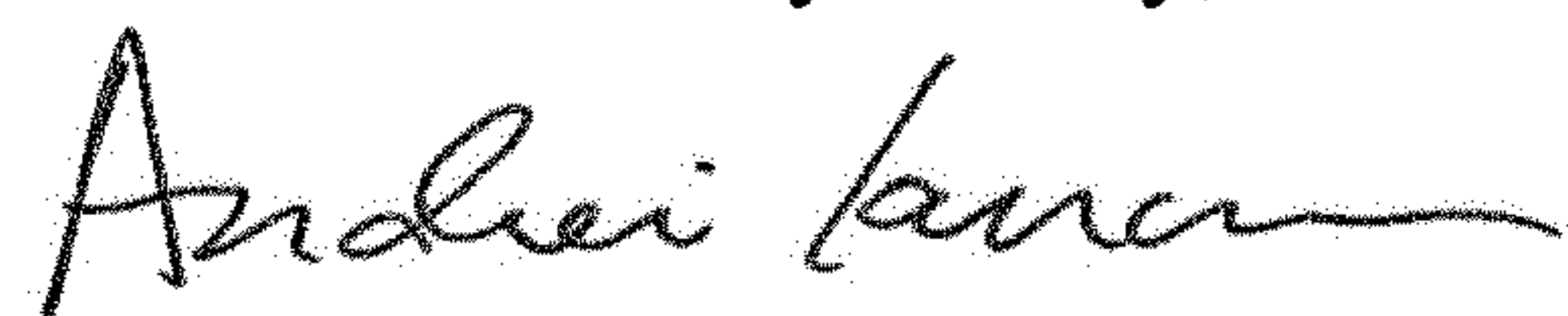

Andrei Iancu  
*Director of the United States Patent and Trademark Office*