

US010669716B2

(12) **United States Patent**
Derelöv

(10) **Patent No.:** **US 10,669,716 B2**
(45) **Date of Patent:** ***Jun. 2, 2020**

(54) **PANELS COMPRISING A MECHANICAL LOCKING DEVICE AND AN ASSEMBLED PRODUCT COMPRISING THE PANELS**

(58) **Field of Classification Search**
CPC E04C 2/38; E04C 2/40
See application file for complete search history.

(71) Applicant: **VÄLINGE INNOVATION AB**, Viken (SE)

(56) **References Cited**

(72) Inventor: **Peter Derelöv**, Helsingborg (SE)

U.S. PATENT DOCUMENTS

(73) Assignee: **VALINGE INNOVATION AB**, Viken (SE)

291,032 A 1/1884 Cleland
634,581 A 10/1899 Miller
(Continued)

(*) Notice: Subject to any disclaimer, the term of this patent is extended or adjusted under 35 U.S.C. 154(b) by 0 days.

FOREIGN PATENT DOCUMENTS

This patent is subject to a terminal disclaimer.

CH 365 507 A 11/1962
CH 685 276 A5 5/1995
(Continued)

(21) Appl. No.: **15/923,701**

OTHER PUBLICATIONS

(22) Filed: **Mar. 16, 2018**

U.S. Appl. No. 15/956,949, Derelöv.

(65) **Prior Publication Data**
US 2018/0202160 A1 Jul. 19, 2018

(Continued)

Related U.S. Application Data

Primary Examiner — Patrick J Maestri

(63) Continuation of application No. 15/366,704, filed on Dec. 1, 2016, now Pat. No. 9,945,121.

(74) *Attorney, Agent, or Firm* — Buchanan Ingersoll & Rooney P.C.

(30) **Foreign Application Priority Data**

(57) **ABSTRACT**

Dec. 3, 2015 (SE) 1551591

A set of panels including a first panel, a second, and a locking device. The locking device includes an edge groove at the first edge and a tongue groove at the second edge. The edge groove includes a flexible tongue arranged in an insertion groove at a first side of the edge groove. The edge groove includes a first groove surface at a first side of the insertion groove and a second groove surface at a second side of the insertion groove. The second edge includes a first edge surface at a first side of the tongue groove and a second edge surface at a second side of the tongue groove. The locking device is configured to be unlocked by inserting a tool in the tongue groove. The first groove surface is arranged offset in a second direction relative to the second groove surface by a first distance.

(51) **Int. Cl.**
E04C 2/38 (2006.01)
F16B 12/46 (2006.01)
(Continued)

(52) **U.S. Cl.**
CPC *E04C 2/38* (2013.01); *A47B 47/04* (2013.01); *A47B 47/042* (2013.01); *E04C 2/40* (2013.01);
(Continued)

4 Claims, 9 Drawing Sheets

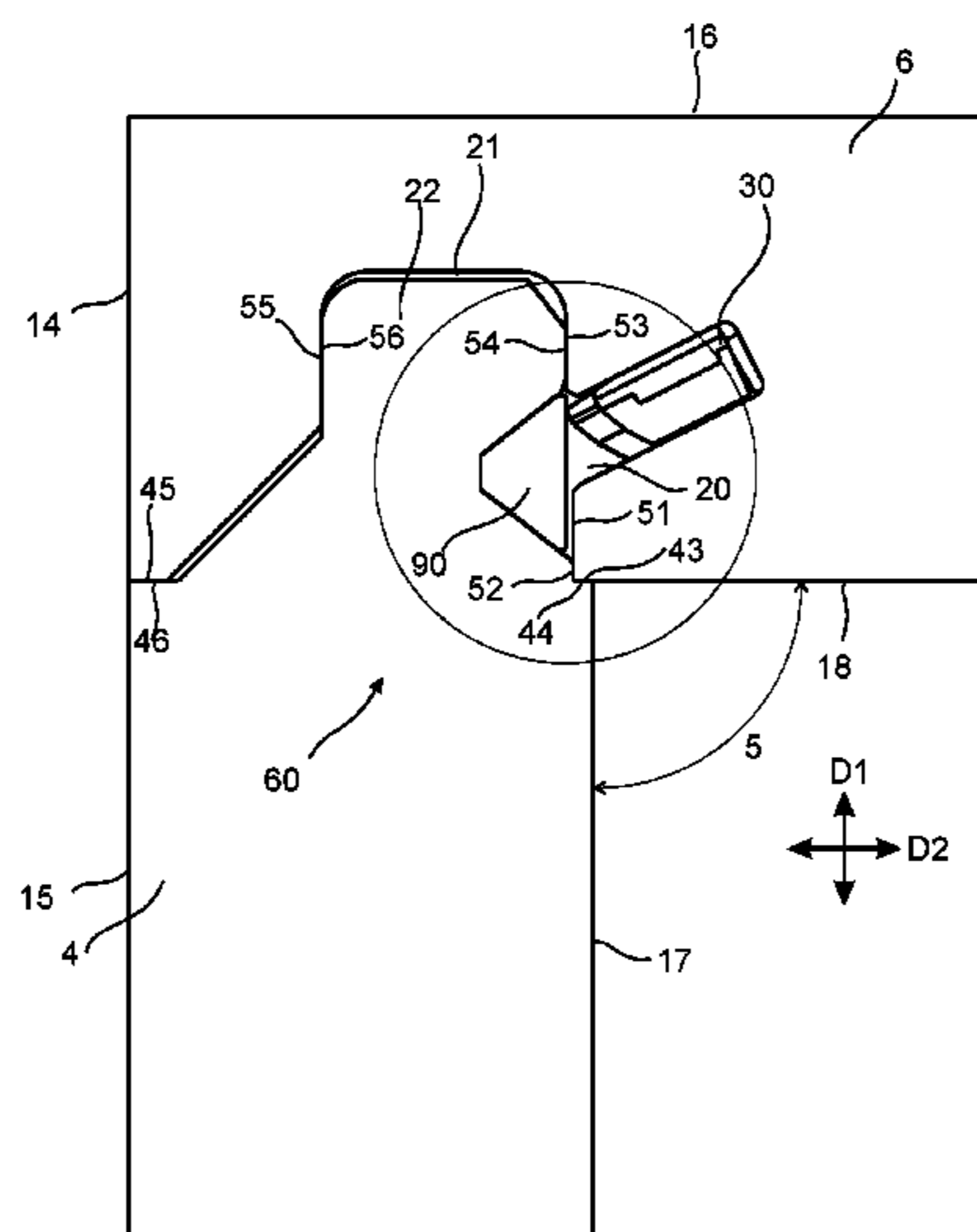

(51)	Int. Cl.		5,004,116 A	4/1991	Cattarozzi	
	<i>A47B 47/04</i>	(2006.01)	5,018,323 A	5/1991	Clausen	
	<i>F16B 12/12</i>	(2006.01)	5,109,993 A	5/1992	Hutchison	
	<i>F16B 12/44</i>	(2006.01)	5,114,265 A	5/1992	Grisley	
	<i>F16B 12/26</i>	(2006.01)	5,121,578 A	6/1992	Holz	
	<i>F16B 12/24</i>	(2006.01)	5,125,518 A	6/1992	Ward	
	<i>F16B 12/24</i>	(2006.01)	5,138,803 A	8/1992	Grossen	
	<i>E04C 2/40</i>	(2006.01)	5,209,556 A	5/1993	Anderson	
(52)	U.S. Cl.		5,212,925 A	5/1993	McClinton	
	CPC	<i>F16B 12/125</i> (2013.01); <i>F16B 12/24</i>	5,360,121 A	11/1994	Sothman	
		(2013.01); <i>F16B 12/26</i> (2013.01); <i>F16B 12/44</i>	5,375,802 A	12/1994	Branham, II	
		(2013.01); <i>F16B 12/46</i> (2013.01); <i>A47B</i>	5,423,155 A	6/1995	Bauer	
		<i>2230/0081</i> (2013.01); <i>A47B 2230/0096</i>	5,451,102 A	9/1995	Chuan	
		(2013.01)	5,458,433 A *	10/1995	Stastny	B27F 5/02 144/136.95
(56)	References Cited		5,471,804 A	12/1995	Winter, IV	
	U.S. PATENT DOCUMENTS		5,475,960 A	12/1995	Lindal	
	701,000 A	5/1902 Ahrens	5,499,667 A	3/1996	Nakanishi	
	861,911 A	7/1907 Stewart	5,499,886 A	3/1996	Short et al.	
	881,673 A	3/1908 Ellison	5,507,331 A	4/1996	Nakanishi	
	1,533,099 A	4/1925 Carroll	5,527,103 A	6/1996	Pittman	
	1,534,468 A	4/1925 Shea, Jr.	5,658,086 A	8/1997	Brokaw et al.	
	1,800,386 A	4/1931 Hoffman	5,711,115 A	1/1998	Wirt	
	1,800,387 A	4/1931 Greist	5,775,521 A	7/1998	Tisbo	
	1,802,245 A	4/1931 Foretich	5,810,505 A	9/1998	Henriott	
	1,954,242 A	4/1934 Heppenstall	5,893,617 A	4/1999	Lee	
	2,360,451 A	10/1944 Stone	5,941,026 A	8/1999	Eisenreich	
	2,362,904 A	11/1944 Kramer	5,944,294 A	8/1999	Baer	
	2,496,184 A	1/1950 Von Canon	5,950,389 A	9/1999	Porter	
	2,681,483 A	6/1954 Morawetz	6,045,290 A	4/2000	Nocievski	
	3,002,630 A	10/1961 Heisser	6,050,426 A	4/2000	Leurdijk	
	3,195,968 A	7/1965 Freeman	6,142,436 A	11/2000	Thurston et al.	
	3,284,152 A	11/1966 Schörghuber	6,312,186 B1	11/2001	Röck et al.	
	3,313,054 A	4/1967 Madey	6,363,645 B1	4/2002	Hunter	
	3,347,610 A	10/1967 Pilliod	6,413,007 B1	7/2002	Lambright	
	3,410,441 A	11/1968 Rhyne	6,418,683 B1	7/2002	Martensson	
	3,722,704 A	3/1973 Piretti	6,491,172 B2	12/2002	Chance	
	3,722,971 A	3/1973 Zeischegg	6,505,452 B1	1/2003	Hannig	
	3,742,807 A	7/1973 Manning	6,547,086 B1	4/2003	Harvey	
	3,765,465 A	10/1973 Gulistan	6,578,498 B1	6/2003	Draudt et al.	
	3,784,271 A	1/1974 Schreiber	6,675,979 B2	1/2004	Taylor	
	3,884,002 A	5/1975 Logie	D486,676 S	2/2004	Campbell et al.	
	3,885,845 A	5/1975 Krieks	6,769,219 B2	8/2004	Schwitte et al.	
	3,981,118 A	9/1976 Johnson et al.	6,772,890 B2	8/2004	Campbell et al.	
	4,089,614 A	5/1978 Harley	6,827,028 B1	12/2004	Callaway	
	4,099,887 A	7/1978 Mackenroth	6,971,614 B2	12/2005	Fischer et al.	
	4,116,510 A	9/1978 Franco	7,127,860 B2	10/2006	Pervan	
	4,142,271 A	3/1979 Busse	7,223,045 B2	5/2007	Migli	
	4,211,379 A	7/1980 Morgan et al.	7,228,977 B2	6/2007	Perkins et al.	
	4,222,544 A	9/1980 Crowder	7,300,120 B2	11/2007	Shin	
	4,279,397 A	7/1981 Larsson	7,451,535 B2	11/2008	Wells et al.	
	4,299,067 A	11/1981 Bertschi	7,451,578 B2	11/2008	Hannig	
	4,308,961 A	1/1982 Kunce	7,584,583 B2	9/2009	Bergelin et al.	
	4,324,517 A	4/1982 Dey	7,614,350 B2	11/2009	Tuttle et al.	
	4,403,886 A	9/1983 Haeusler	7,621,092 B2	11/2009	Groeke et al.	
	4,405,253 A	9/1983 Stockum	7,641,414 B1	1/2010	Joyce	
	4,509,648 A	4/1985 Govang	7,717,278 B2	5/2010	Kao	
	4,593,734 A	6/1986 Wallace	7,721,503 B2	5/2010	Pervan et al.	
	4,595,105 A	6/1986 Gold	7,793,450 B2	9/2010	Chasmer et al.	
	4,597,122 A	7/1986 Handler	7,818,939 B2	10/2010	Bearinger	
	4,615,448 A	10/1986 Johnstonbaugh	7,998,549 B2	8/2011	Susnjara	
	4,629,076 A	12/1986 Amstutz et al.	8,033,074 B2	10/2011	Pervan	
	4,750,794 A	6/1988 Vegh	8,038,363 B2	10/2011	Hannig	
	4,752,150 A	6/1988 Salice	8,042,311 B2	10/2011	Pervan	
	4,815,908 A	3/1989 Duran et al.	8,146,754 B2	4/2012	Apgood	
	4,817,900 A	4/1989 Whittington	8,220,217 B2	7/2012	Muehlebach	
	4,844,266 A	7/1989 Small	8,234,830 B2	8/2012	Pervan	
	4,883,331 A	11/1989 Mengel	8,365,499 B2	2/2013	Nilsson et al.	
	4,886,326 A	12/1989 Kuzyk	8,387,327 B2	3/2013	Pervan	
	4,888,933 A	12/1989 Guomundsson	8,464,408 B2	6/2013	Hazzard	
	4,891,897 A	1/1990 Gieske et al.	8,495,849 B2	7/2013	Pervan	
	4,909,581 A	3/1990 Haheeb	8,505,257 B2	8/2013	Boo et al.	
	4,938,625 A	7/1990 Matsui	8,544,230 B2	10/2013	Pervan	
	4,944,416 A	7/1990 Petersen et al.	8,596,013 B2	12/2013	Boo	
	4,961,295 A	10/1990 Kosch, Sr. et al.	8,602,227 B1	12/2013	McDonald	
			8,615,952 B2	12/2013	Engström	
			8,713,886 B2	5/2014	Pervan	
			8,745,952 B2	6/2014	Perra	
			8,764,137 B2	7/2014	Fehre	

(56)

References Cited

U.S. PATENT DOCUMENTS

8,776,473 B2 7/2014 Pervan
 8,833,028 B2 9/2014 Whispell et al.
 8,864,407 B1 10/2014 Sorum
 8,882,416 B2 11/2014 Baur et al.
 8,887,468 B2 11/2014 Håkansson et al.
 9,175,703 B2 11/2015 Maertens
 9,216,541 B2 12/2015 Boo
 9,290,948 B2 3/2016 Cappelle et al.
 9,375,085 B2 6/2016 Derelöv
 9,538,842 B2 1/2017 Håkansson et al.
 9,655,442 B2 5/2017 Boo et al.
 9,700,157 B2 7/2017 Keyvanloo
 9,714,672 B2 7/2017 Derelöv et al.
 9,723,923 B2 8/2017 Derelöv
 9,726,210 B2 8/2017 Derelöv et al.
 9,745,756 B2 8/2017 Hannig
 9,758,973 B2 9/2017 Segaert
 9,763,528 B2 9/2017 Lung
 9,809,983 B2 11/2017 Trudel
 9,945,121 B2 4/2018 Derelöv
 10,034,541 B2 7/2018 Boo et al.
 10,202,996 B2 2/2019 Håkansson et al.
 10,378,570 B2 8/2019 Broughton
 10,415,613 B2 9/2019 Boo
 10,448,739 B2 10/2019 Derelöv et al.
 10,451,097 B2 10/2019 Brännström et al.
 2002/0170258 A1 11/2002 Schwitte et al.
 2004/0165946 A1 8/2004 Areh et al.
 2005/0042027 A1 2/2005 Migli
 2005/0236544 A1 10/2005 Mancino
 2005/0247653 A1 11/2005 Brooks
 2006/0091093 A1 5/2006 Armari
 2006/0101769 A1 5/2006 Pervan et al.
 2006/0180561 A1 8/2006 Wisnoski et al.
 2006/0236642 A1 10/2006 Pervan
 2006/0273085 A1 12/2006 Casto
 2007/0006543 A1 1/2007 Engström
 2007/0028547 A1 2/2007 Grafenauer et al.
 2008/0010937 A1 1/2008 Pervan et al.
 2008/0066415 A1 3/2008 Pervan
 2008/0193209 A1 8/2008 Henderson
 2008/0216435 A1 9/2008 Nolan
 2008/0236088 A1 10/2008 Hannig et al.
 2009/0014401 A1 1/2009 Tallman
 2009/0064624 A1 3/2009 Sokol
 2010/0028592 A1 2/2010 Barkdoll et al.
 2010/0083603 A1 4/2010 Goodwin
 2010/0104354 A1 4/2010 Spalding
 2010/0173122 A1 7/2010 Susnjara
 2010/0289389 A1 11/2010 Crabtree, II
 2011/0023303 A1 2/2011 Pervan et al.
 2011/0225921 A1 9/2011 Schulte
 2011/0225922 A1 9/2011 Pervan et al.
 2011/0280655 A1 11/2011 Maertens et al.
 2011/0283650 A1 11/2011 Pervan et al.
 2012/0009383 A1 1/2012 Hardesty
 2012/0027967 A1 2/2012 Maertens et al.
 2012/0073235 A1 3/2012 Hannig
 2012/0124932 A1 5/2012 Schulte et al.
 2012/0145845 A1 6/2012 Hightower
 2012/0180416 A1 7/2012 Perra et al.
 2012/0279161 A1* 11/2012 Hakansson A47B 47/0075
 52/588.1
 2012/0286637 A1 11/2012 Fehre
 2013/0014463 A1 1/2013 Pervan
 2013/0048632 A1 2/2013 Chen
 2013/0071172 A1 3/2013 Maertens et al.
 2013/0081349 A1 4/2013 Pervan
 2013/0097846 A1 4/2013 Pettigrew
 2013/0111845 A1 5/2013 Pervan
 2013/0170904 A1 7/2013 Cappelle et al.
 2013/0232905 A2 9/2013 Pervan
 2013/0287484 A1 10/2013 Phillips
 2014/0013919 A1 1/2014 Gerke et al.
 2014/0055018 A1 2/2014 Shein et al.

2014/0111076 A1 4/2014 Devos
 2014/0286701 A1 9/2014 Sauer
 2014/0294498 A1 10/2014 Logan
 2015/0034522 A1 2/2015 Itou et al.
 2015/0035422 A1 2/2015 Håkansson et al.
 2015/0078807 A1 3/2015 Brännström et al.
 2015/0078819 A1 3/2015 Derelöv et al.
 2015/0196118 A1 7/2015 Derelöv
 2015/0198191 A1 7/2015 Boo
 2015/0230600 A1 8/2015 Schulte
 2015/0368896 A1 12/2015 Schulte
 2016/0000220 A1 1/2016 Devos
 2016/0007751 A1 1/2016 Derelöv
 2016/0145029 A1 5/2016 Ranade et al.
 2016/0174704 A1 6/2016 Boo et al.
 2016/0186925 A1 6/2016 Bettin
 2016/0192775 A1 7/2016 Andersson
 2016/0270531 A1 9/2016 Derelöv
 2017/0079433 A1 3/2017 Derelöv et al.
 2017/0089379 A1 3/2017 Pervan
 2017/0097033 A1 4/2017 Håkansson et al.
 2017/0159291 A1 6/2017 Derelöv
 2017/0208938 A1 7/2017 Derelöv et al.
 2017/0227031 A1 8/2017 Boo
 2017/0227032 A1 8/2017 Fridlund
 2017/0227035 A1 8/2017 Fridlund
 2017/0234346 A1 8/2017 Fridlund
 2017/0298973 A1 10/2017 Derelöv
 2017/0360193 A1 12/2017 Boo et al.
 2018/0080488 A1 3/2018 Derelöv
 2018/0087552 A1 3/2018 Derelöv et al.
 2018/0112695 A1 4/2018 Boo et al.
 2018/0119717 A1 5/2018 Derelöv
 2018/0283430 A1 10/2018 Leistert
 2018/0328396 A1 11/2018 Fransson et al.
 2019/0113061 A1 4/2019 Håkansson et al.
 2019/0166989 A1 6/2019 Boo et al.
 2019/0191870 A1 6/2019 Derelöv
 2019/0195256 A1 6/2019 Derelöv
 2019/0289999 A1 9/2019 Derelöv et al.
 2019/0320793 A1 10/2019 Boo
 2019/0323532 A1 10/2019 Boo
 2019/0323533 A1 10/2019 Boo
 2019/0323534 A1 10/2019 Derelöv
 2019/0323535 A1 10/2019 Derelöv
 2020/0003242 A1 1/2020 Brännström et al.

FOREIGN PATENT DOCUMENTS

CH 696 889 A5 1/2008
 CH 698 988 B1 12/2009
 CH 705 082 A2 12/2012
 CN 101099618 A 1/2008
 CN 102 917 616 A 2/2013
 CN 203424576 U 2/2014
 DE 31 03 281 A1 8/1982
 DE 228 872 A1 10/1985
 DE 42 29 115 A1 3/1993
 DE 94 17 168 U1 2/1995
 DE 198 31 936 A1 2/1999
 DE 298 20 031 U1 2/1999
 DE 198 05 538 A1 8/1999
 DE 203 04 761 U1 4/2004
 DE 299 24 630 U1 5/2004
 DE 20 2004 017 486 U1 4/2006
 DE 20 2009 008 825 U1 10/2009
 DE 10 2008 035 293 A1 2/2010
 DE 10 2009 041 142 A1 3/2011
 DE 10 2011 057 018 A1 6/2013
 DE 10 2013 008 595 A1 11/2013
 DE 10 2014 110 124 A1 1/2016
 DE 20 2017 101 856 U1 4/2017
 EP 0 060 203 A2 9/1982
 EP 0 060 203 A3 9/1982
 EP 0 357 129 A1 3/1990
 EP 0 362 968 A 4/1990
 EP 0 675 332 A2 10/1995
 EP 0 871 156 A2 10/1998
 EP 1 048 423 A2 11/2000

(56)

References Cited

OTHER PUBLICATIONS

FOREIGN PATENT DOCUMENTS

EP	1 048 423 B9	5/2005	
EP	1 650 375 A1	4/2006	
EP	1 671 562 A1	6/2006	
EP	1 650 375 A8	9/2006	
EP	1 922 954 A1	5/2008	
EP	2 017 403 A2	1/2009	
EP	1 922 954 B1	7/2009	
EP	2 333 353 A2	6/2011	
EP	1 863 984 B1	11/2011	
EP	2 487 373 A1	8/2012	
EP	3 031 998 A1	6/2016	
FR	2 517 187 A1	6/1983	
FR	2 597 173 A1	10/1987	
FR	2 602 013 A1	1/1988	
GB	1 022 377 A	3/1966	
GB	2 163 825 A	3/1986	
GB	2 482 213 A	1/2012	
GB	2 520 927 A	6/2015	
JP	S53-113160 U	9/1978	
JP	2003-239921 A	8/2003	
KR	10-1147274 B1	5/2012	
KR	2014-0042314 A	4/2014	
WO	WO 87/07339 A1	12/1987	
WO	WO 90/07066	6/1990	
WO	WO 99/22150 A1	5/1999	
WO	WO 99/41508 A2	8/1999	
WO	WO 00/66856 A1	11/2000	
WO	WO 01/53628 A1	7/2001	
WO	WO 02/055809 A1	7/2002	
WO	WO 02/055810 A1	7/2002	
WO	WO 03/083234 A1	10/2003	
WO	WO 2004/079130 A1	9/2004	
WO	WO 2005/068747 A1	7/2005	
WO	WO 2006/043893 A1	4/2006	
WO	WO 2006/104436 A1	10/2006	
WO	WO 2007/015669 A2	2/2007	
WO	WO 2007/015669 A3	2/2007	
WO	WO 2008/004960 A2	1/2008	
WO	WO 2008/004960 A3	1/2008	
WO	WO 2008/004960 A8	1/2008	
WO	WO 2008/017281 A1	2/2008	
WO	WO 2008/150234 A1	12/2008	
WO	WO-2010070472 A2 *	6/2010 A47B 47/042
WO	WO 2010/087752 A1	8/2010	
WO	WO 2011/151758 A2	12/2011	
WO	WO 2011/151758 A3	12/2011	
WO	WO 2012/095454 A1	7/2012	
WO	WO 2012/154113 A1	11/2012	
WO	WO 2013/009257 A1	1/2013	
WO	WO 2013/025163 A1	2/2013	
WO	WO 2013/080160 A1	6/2013	
WO	WO 2013/118075 A1	8/2013	
WO	WO 2014/072080 A1	5/2014	
WO	WO 2014/121410 A1	8/2014	
WO	WO 2015/015603 A1	2/2015	
WO	WO 2015/038059 A1	3/2015	
WO	WO 2015/105449 A1	7/2015	
WO	WO 2015/105450 A1	7/2015	
WO	WO 2015/105451 A1	7/2015	
WO	WO 2016/099396 A1	6/2016	
WO	WO 2016/175701 A1	11/2016	
WO	WO 2017/131574 A1	8/2017	
WO	WO 2017/138874 A1	8/2017	
WO	WO 2018/080387 A1	5/2018	
WO	WO 2019/125291 A1	6/2019	
WO	WO 2019/125292 A1	6/2019	

U.S. Appl. No. 16/027,479, Boo, et al.
 U.S. Appl. No. 16/220,574, Derelöv.
 U.S. Appl. No. 16/220,585, Derelöv.
 U.S. Appl. No. 16/361,609, Derelöv et al.
 U.S. Appl. No. 16/386,732, Boo.
 U.S. Appl. No. 16/386,810, Boo.
 U.S. Appl. No. 16/386,824, Boo.
 U.S. Appl. No. 16/386,874, Derelöv.
 International Search Report/Written Opinion dated Feb. 21, 2017 in PCT/SE2016/051197, ISA/SE, Patent-och registreringsverket, Stockholm, Sweden, 18 pages.
 Extended European Search Report issued in EP Application No. 16871156.2, dated Mar. 21, 2019, European Patent Office, Munich, DE, 8 pages.
 Derelöv, Peter, U.S. Appl. No. 15/956,949 entitled "Panels for an Assembled Product", filed Apr. 19, 2018.
 Boo, Christian, et al., U.S. Appl. No. 16/027,479 entitled "Panels Comprising a Mechanical Locking Device and an Assembled Product Comprising the Panels," filed Jul. 5, 2018.
 Derelöv, Peter, U.S. Appl. No. 16/220,574 entitled "Set of Panels," filed Dec. 14, 2018.
 Derelöv, Peter, U.S. Appl. No. 16/220,585 entitled "Set of Panels," filed Dec. 14, 2018.
 Derelöv, Peter, et al., U.S. Appl. No. 16/361,609 entitled "Panels Comprising a Mechanical Locking Device and an Assembled Product Comprising the Panels," filed Mar. 22, 2019.
 Boo, Christian, U.S. Appl. No. 16/386,732 entitled "Set of Panels With a Mechanical Locking Device," filed Apr. 17, 2019.
 Boo, Christian, U.S. Appl. No. 16/386,810 entitled "Set of Panels With a Mechanical Locking Device," filed Apr. 17, 2019.
 Boo, Christian, U.S. Appl. No. 16/386,824 entitled "Set of Panels With a Mechanical Locking Device," filed Apr. 17, 2019.
 Derelöv, Peter, U.S. Appl. No. 16/386,874 entitled "Symmetric Tongue and T-Cross," filed Apr. 17, 2019.
 U.S. Appl. No. 16/553,325, Derelöv et al.
 U.S. Appl. No. 16/553,350, Derelöv et al.
 U.S. Appl. No. 16/564,438, Brännström et al.
 U.S. Appl. No. 16/567,436, Derelöv.
 U.S. Appl. No. 16/663,603, Fridlund.
 U.S. Appl. No. 16/697,335, Boo et al.
 Derelöv, Peter, U.S. Appl. No. 16/553,325 entitled "Set of Panels with a Mechanical Locking Device," filed Aug. 28, 2019.
 Derelöv, Peter, U.S. Appl. No. 16/553,350 entitled "Set of Panels with a Mechanical Locking Device," filed Aug. 28, 2019.
 Brännström, Hans, et al., U.S. Appl. No. 16/564,438 entitled "Assembled Product and a Method of Assembling the Assembled Product," filed Sep. 9, 2019.
 Derelöv, Peter, U.S. Appl. No. 16/567,436 entitled "Panels Comprising a Mechanical Locking Device and an Assembled Product Comprising the Panels," filed Sep. 11, 2019.
 Fridlund, Magnus, U.S. Appl. No. 16/663,603 entitled "Element and Method for Providing Dismantling Groove," filed Oct. 25, 2019.
 Boo, Christian, et al., U.S. Appl. No. 16/697,335 entitled "Panels Comprising a Mechanical Locking Device and an Assembled Product Comprising the Panels," filed Nov. 27, 2019.
 U.S. Appl. No. 16/703,077, Fridlund.
 U.S. Appl. No. 16/722,096, Derelöv et al.
 Fridlund, Magnus, U.S. Appl. No. 16/703,077 entitled "Set of Panels for an Assembled Product," filed Dec. 4, 2019.
 Derelöv, Peter, et al., U.S. Appl. No. 16/722,096 entitled "Panels Comprising a Mechanical Locking Device and an Assembled Product Comprising the Panels," filed Dec. 20, 2019.

* cited by examiner

FIG 1

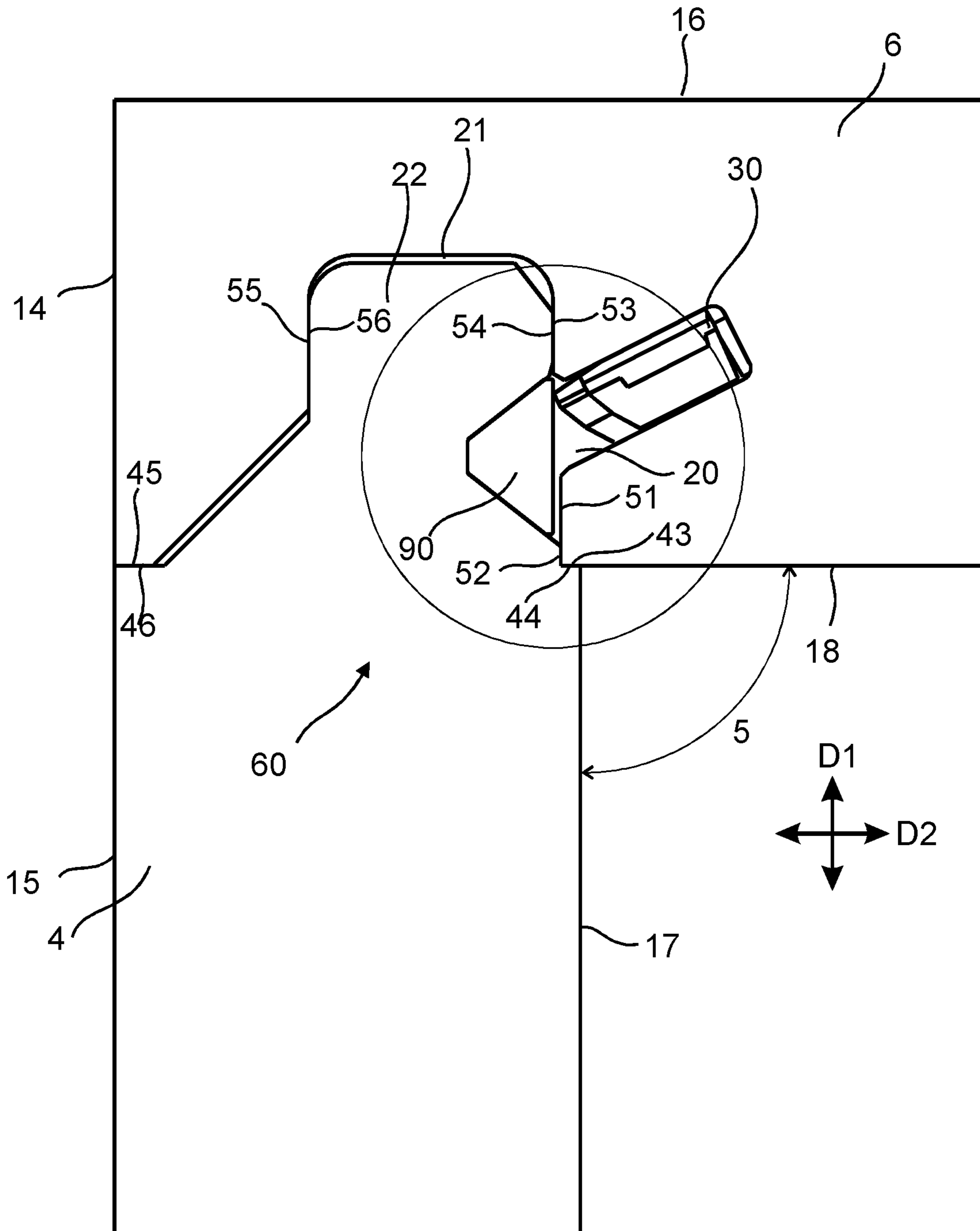

FIG 2

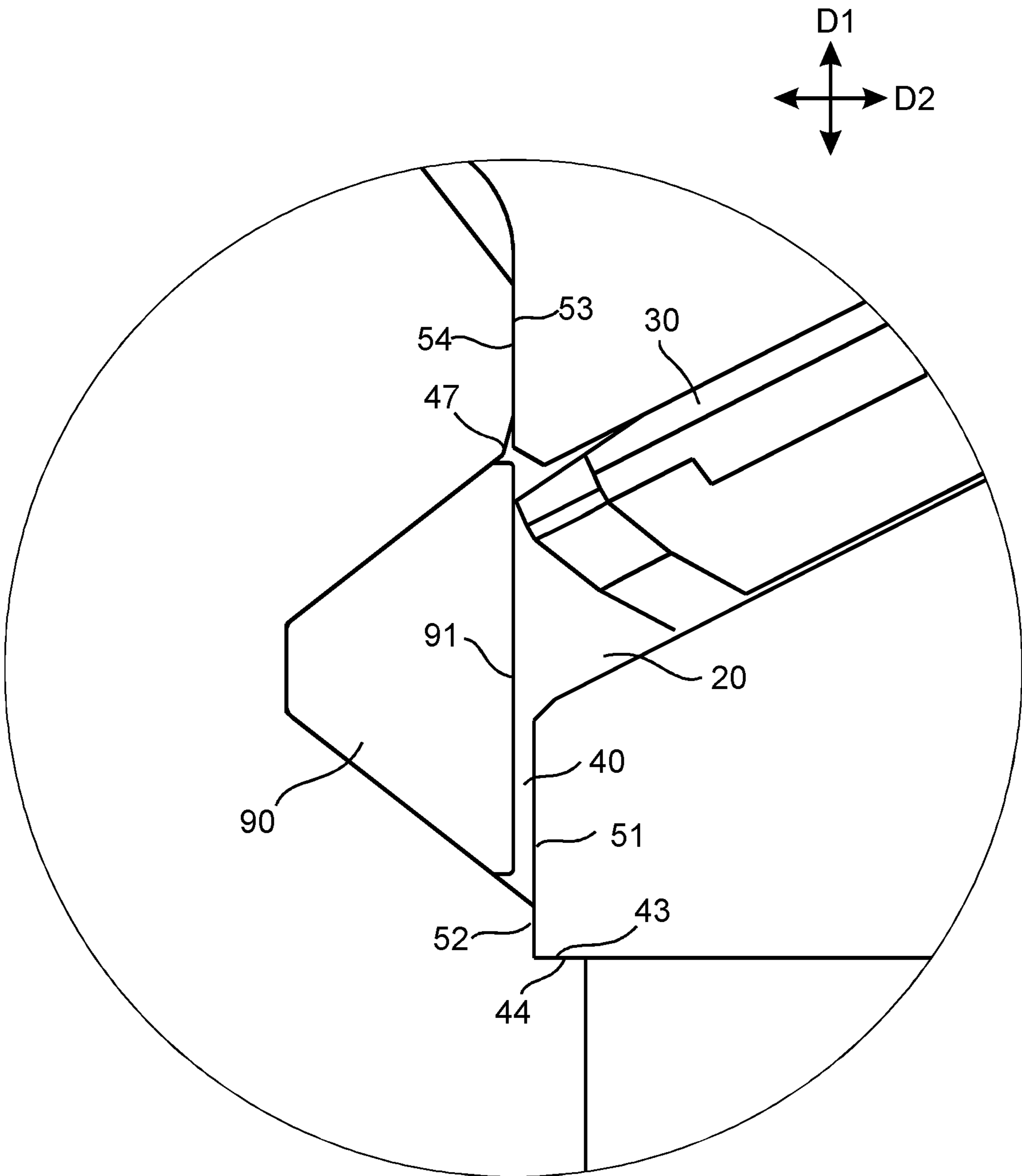

FIG 3A

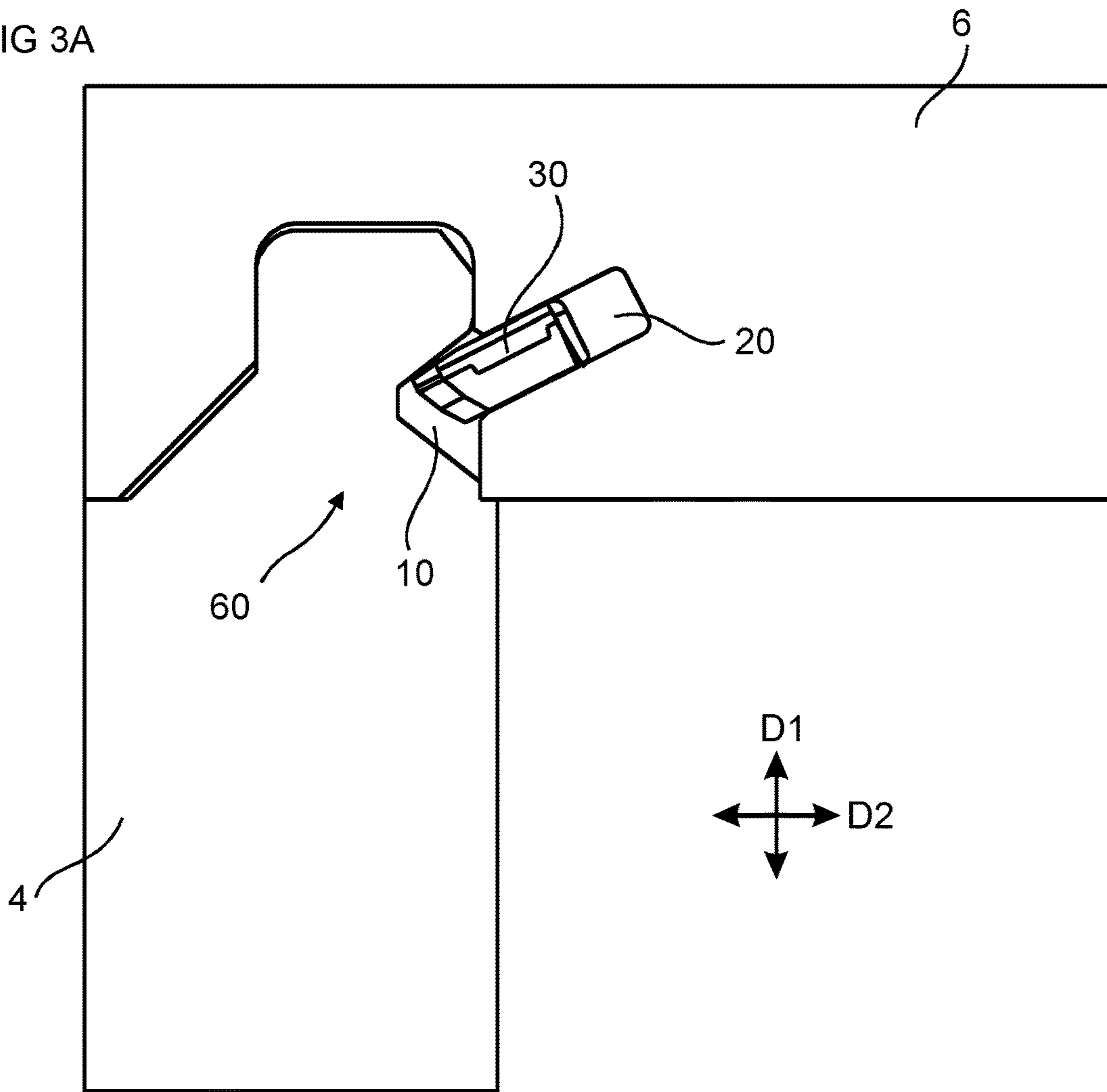

FIG 3B

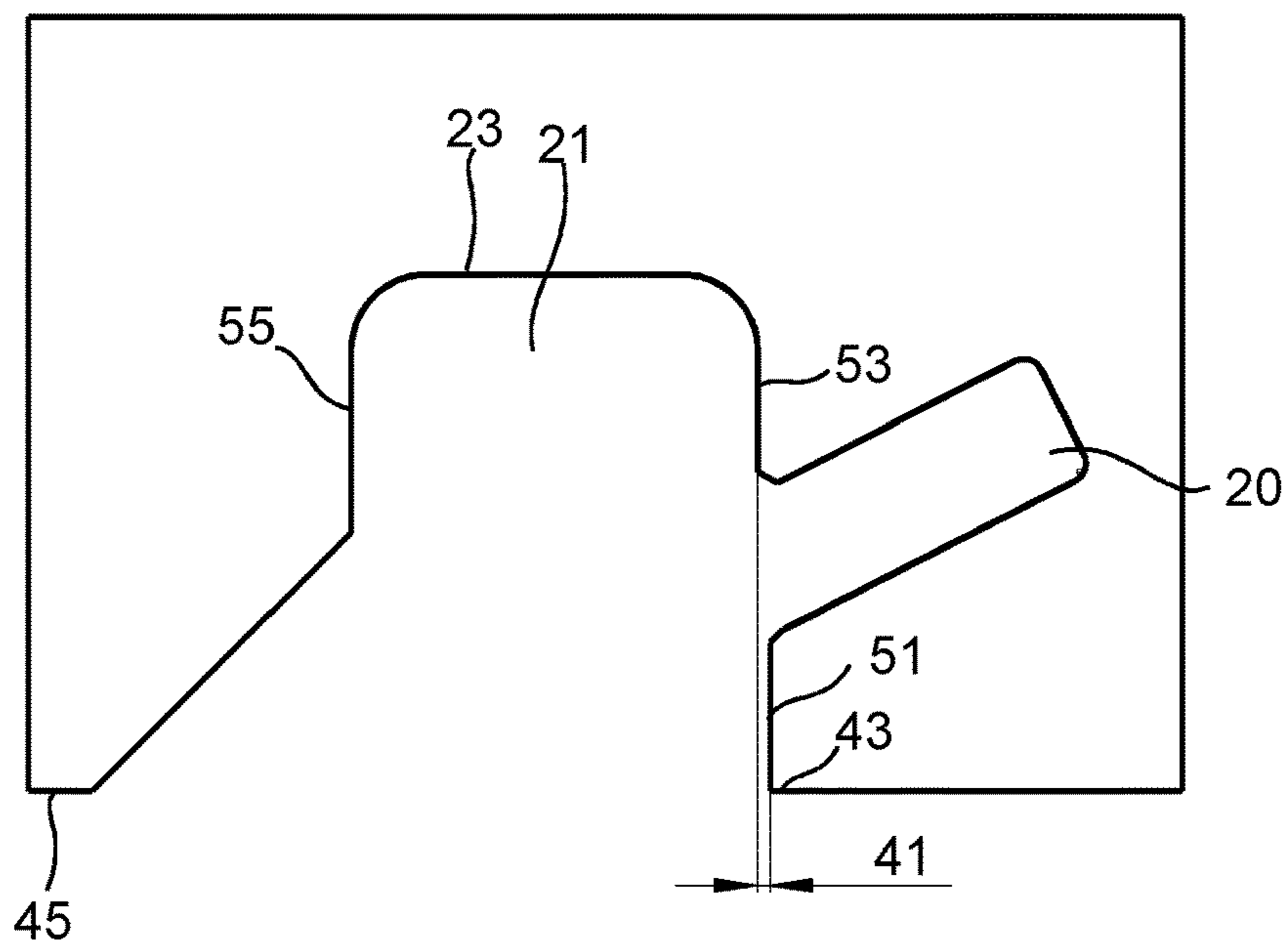

FIG 4A

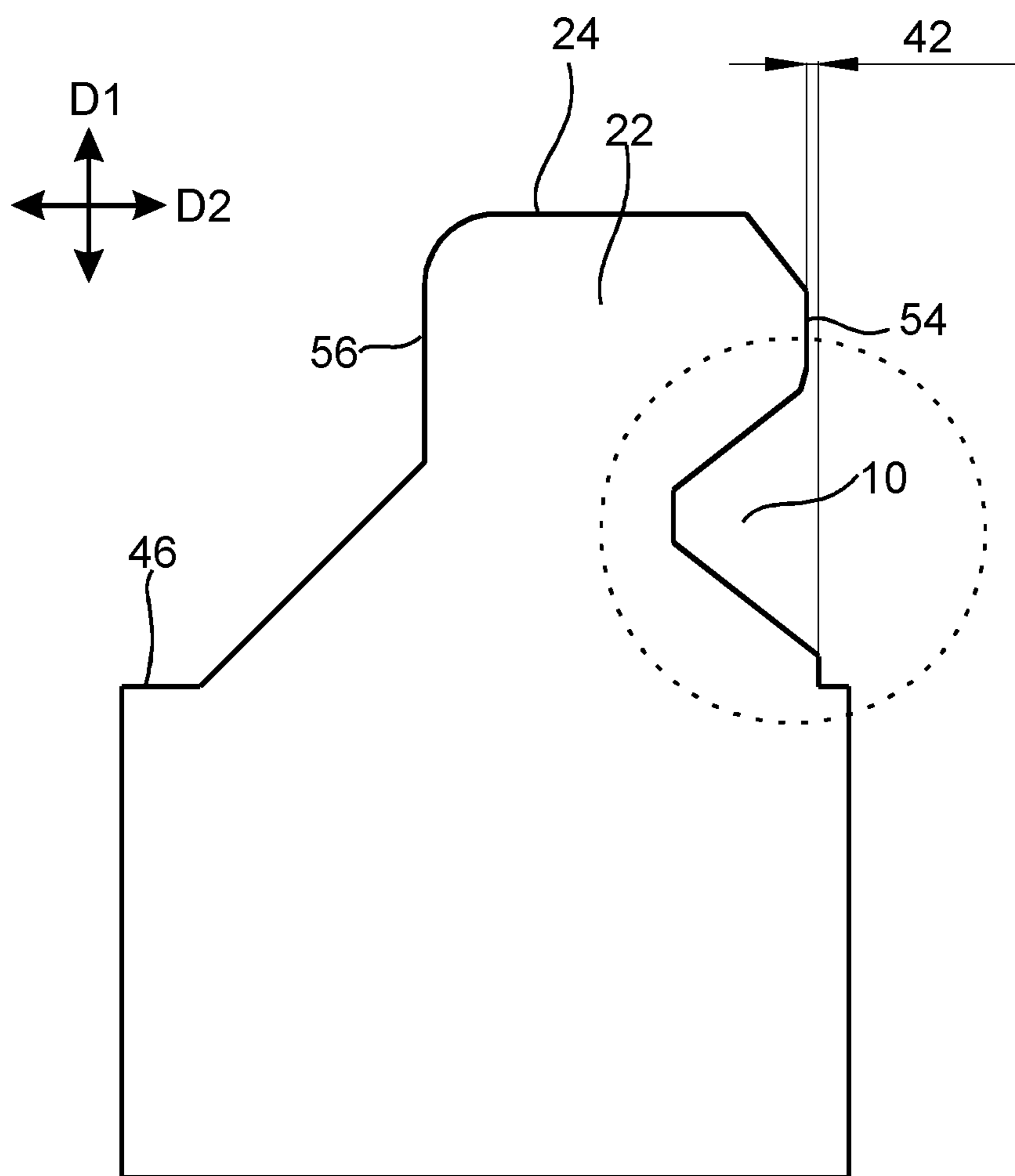

FIG 4B

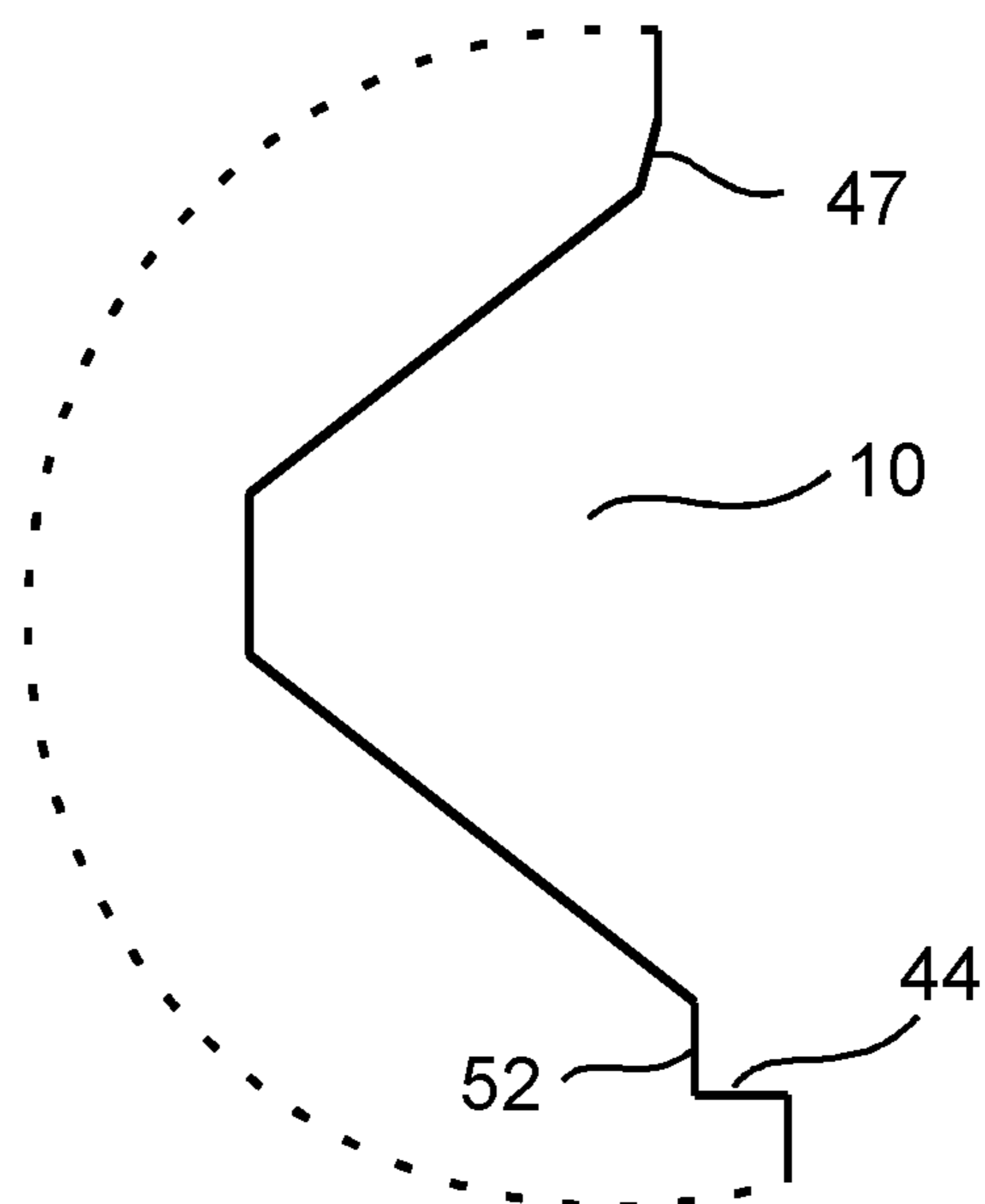

FIG 5

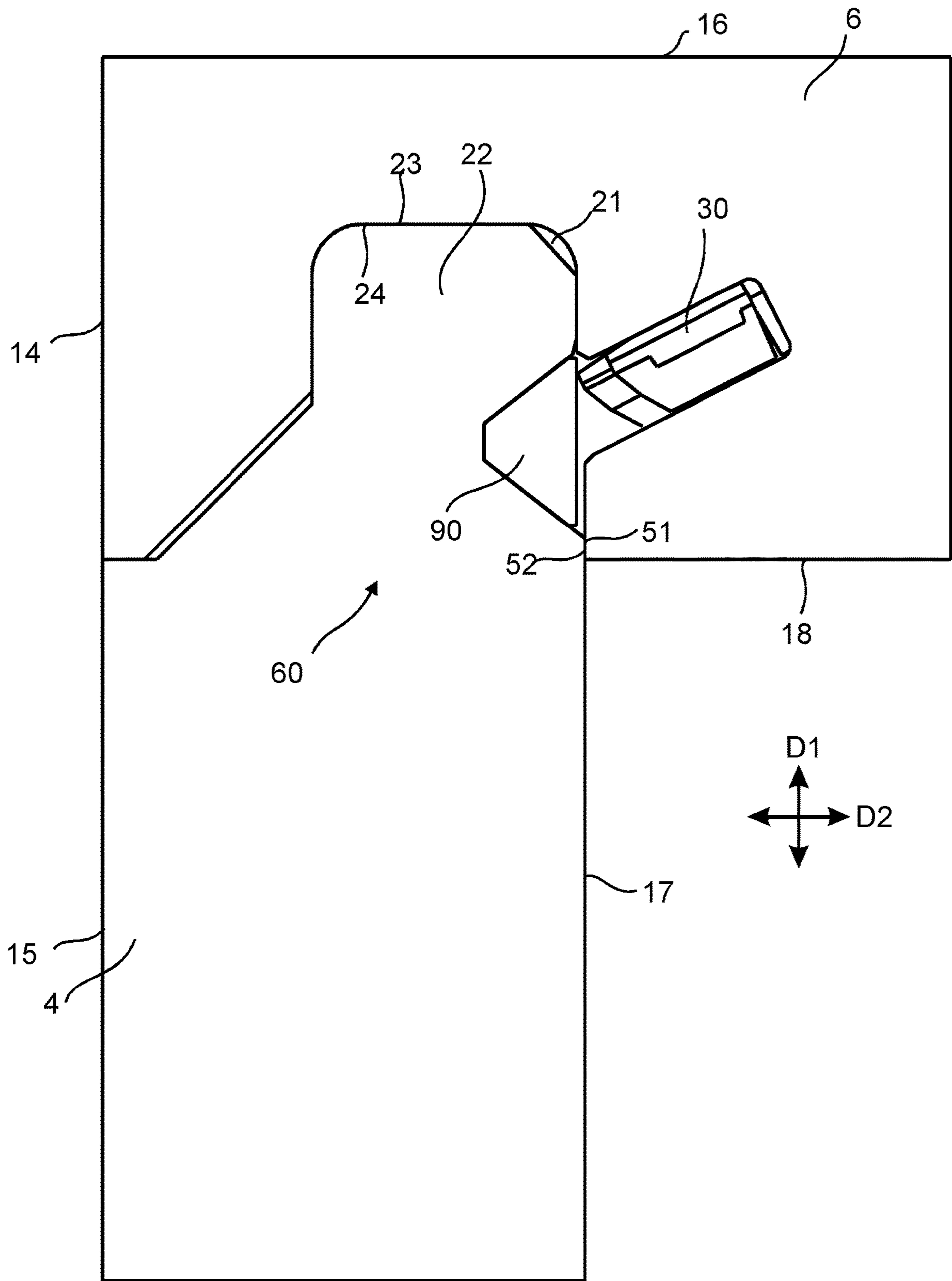

FIG 6

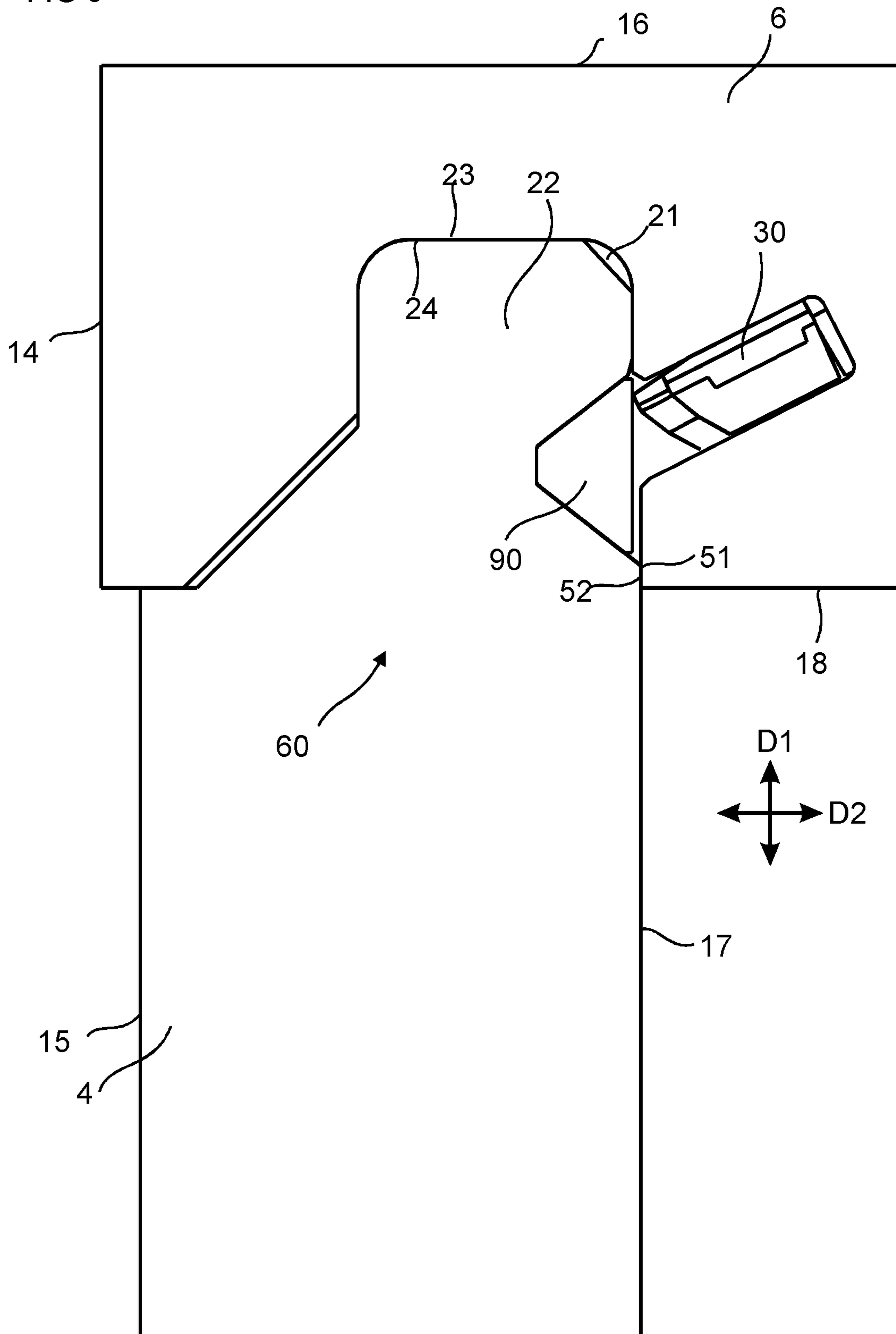

FIG 7

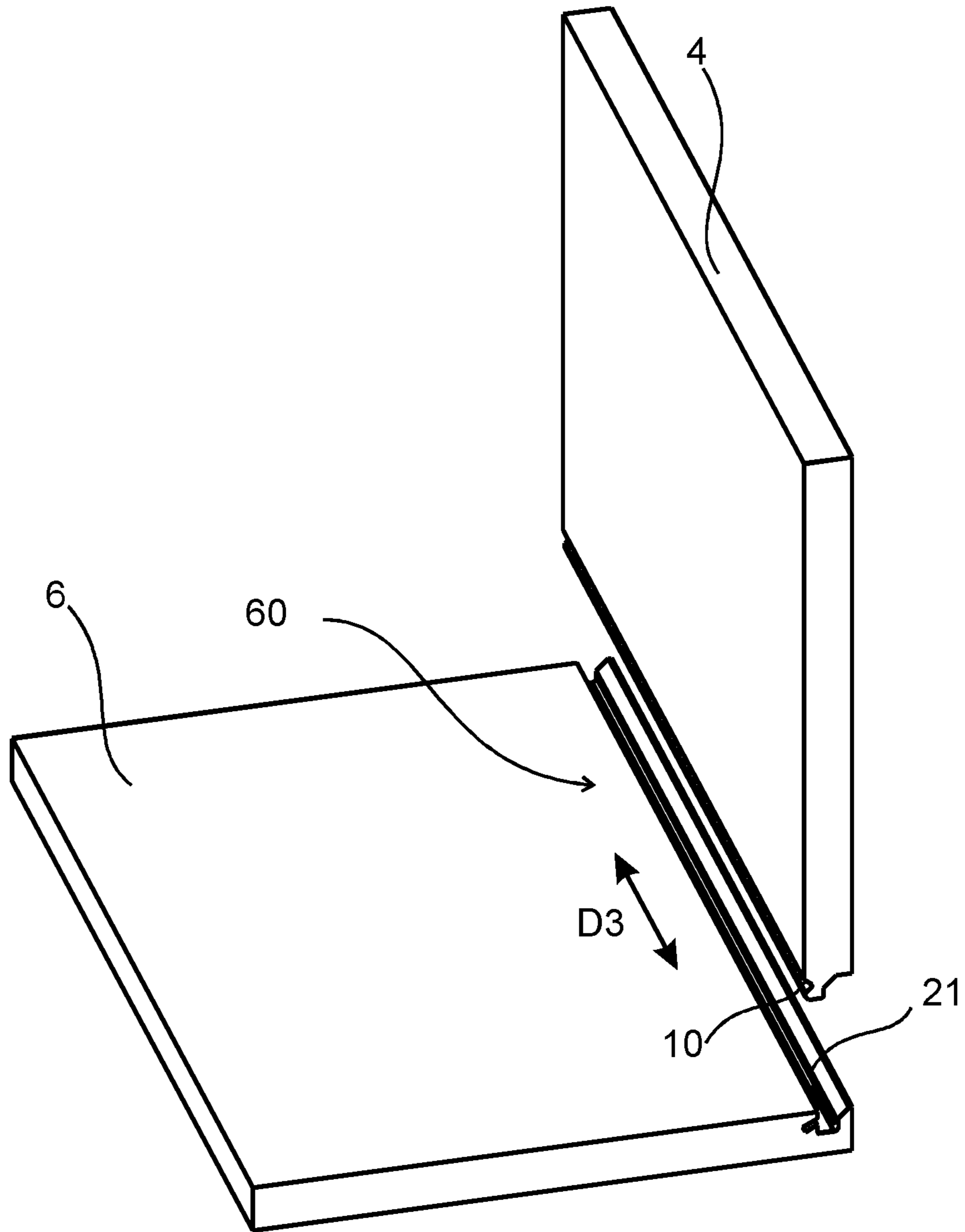

FIG 8A

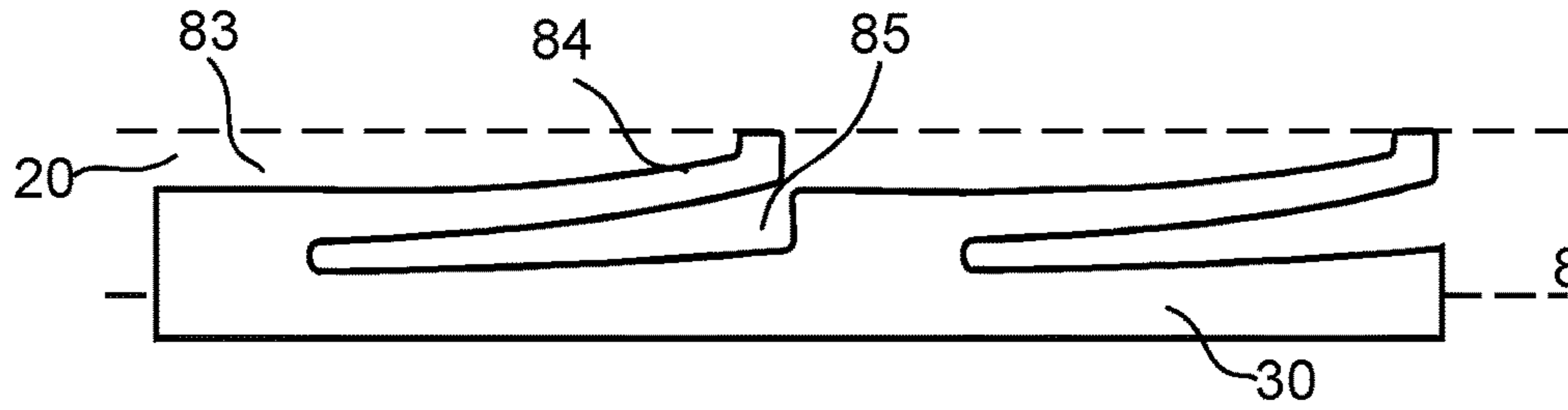

FIG 8B

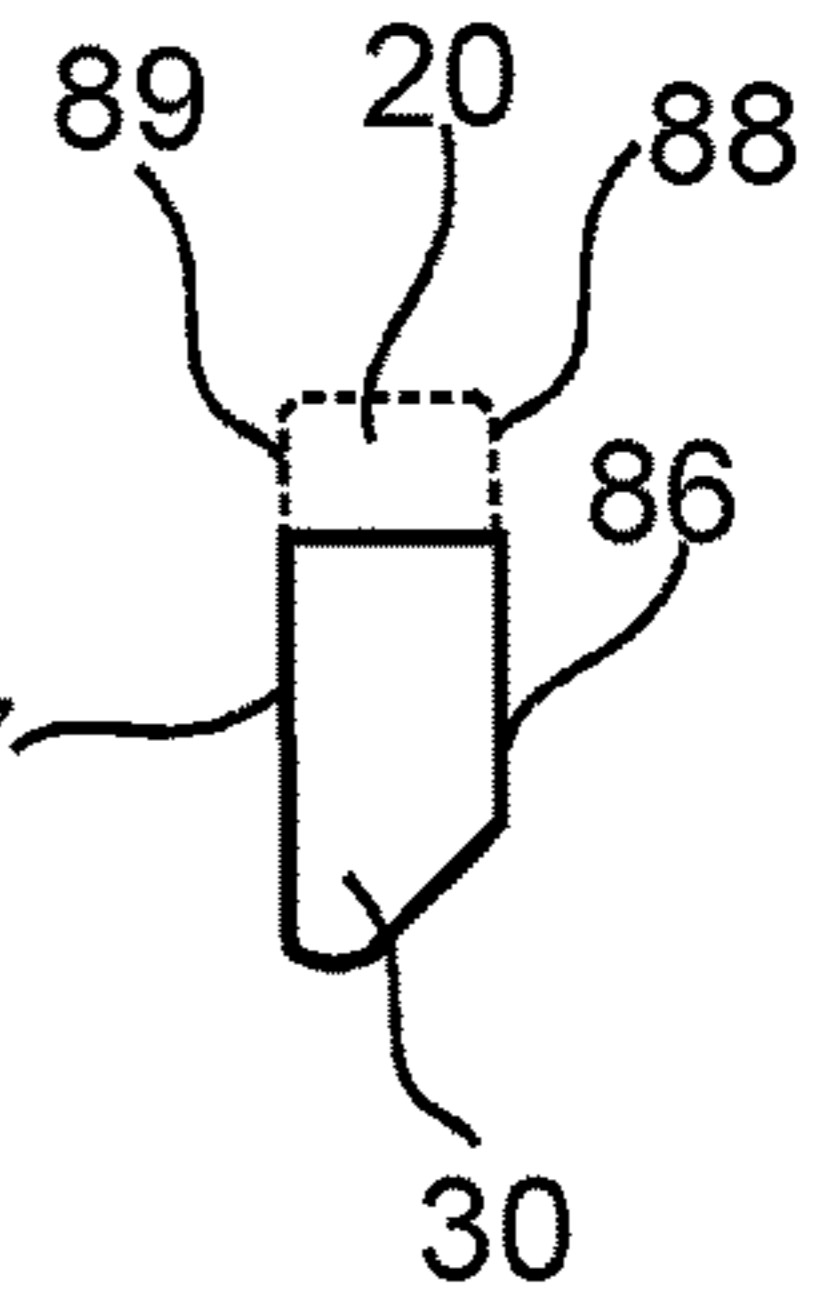

FIG 8C

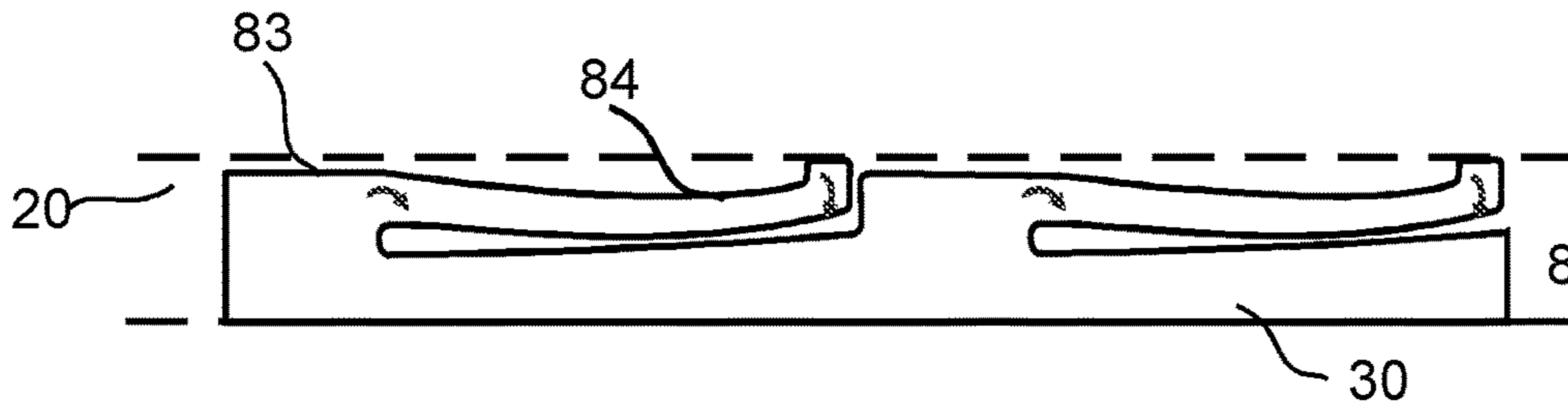

FIG 8D

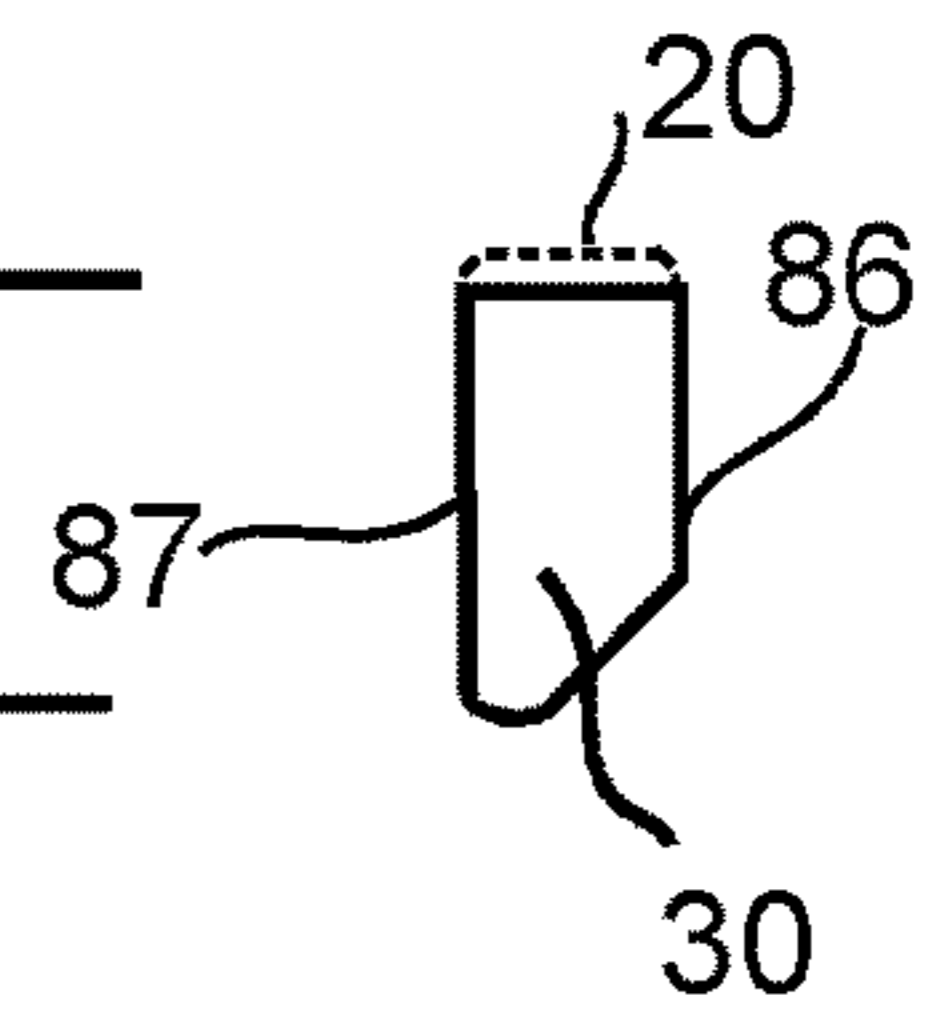

FIG 8E

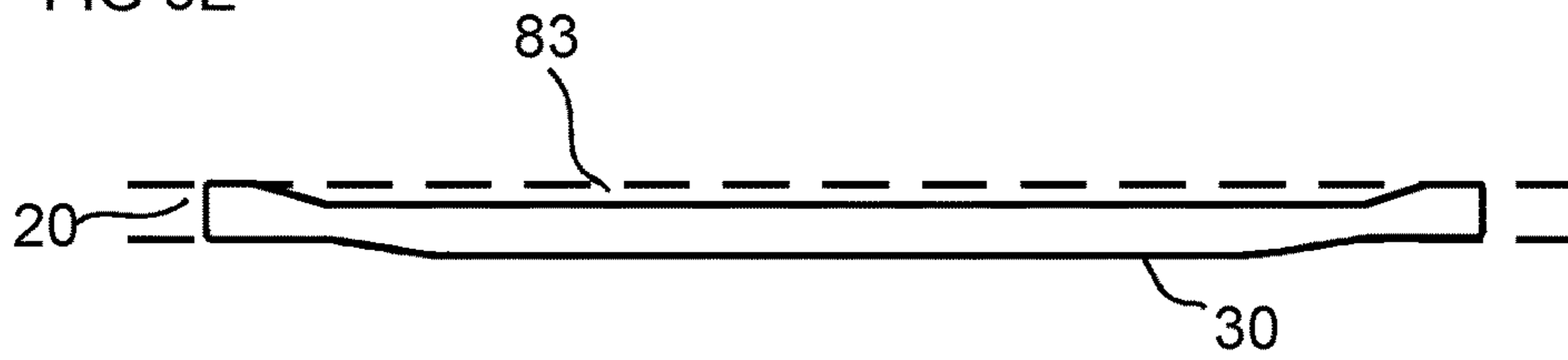
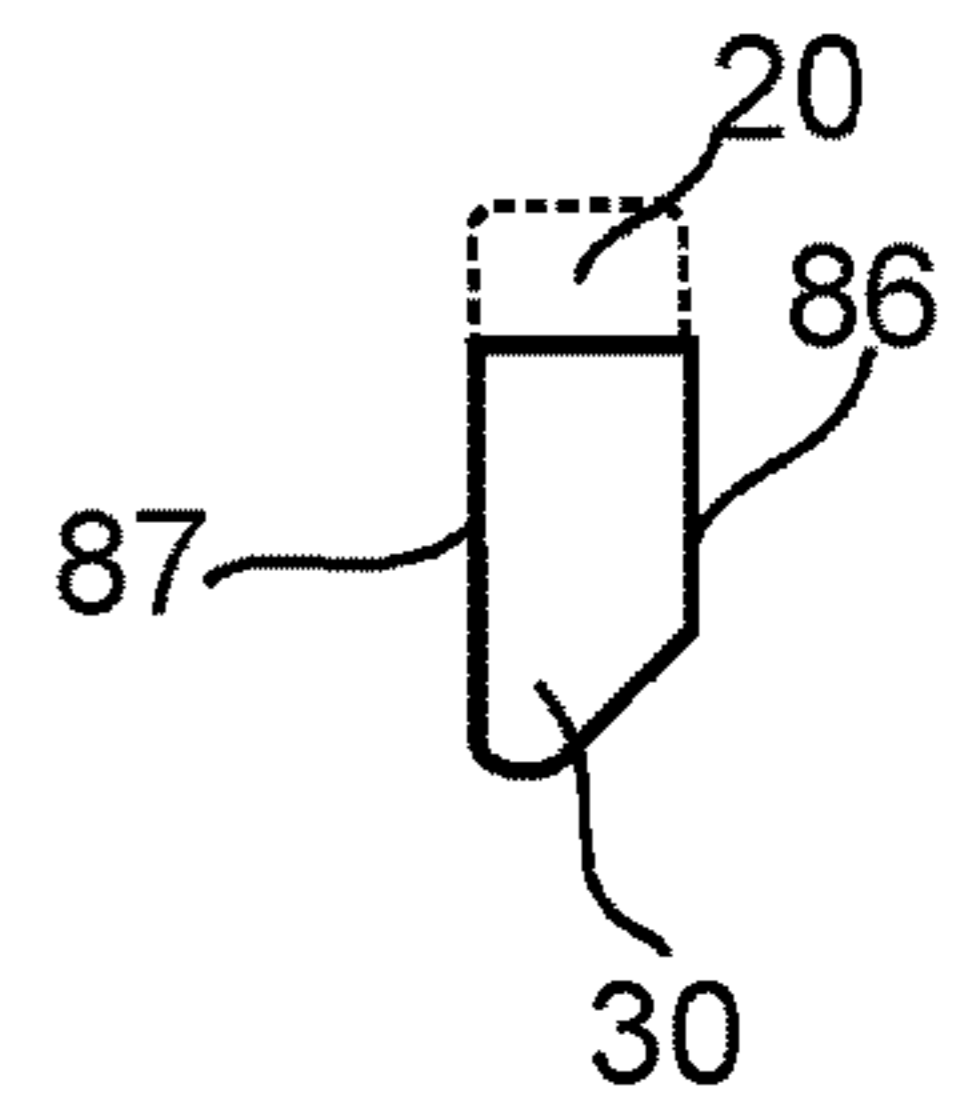

FIG 8F



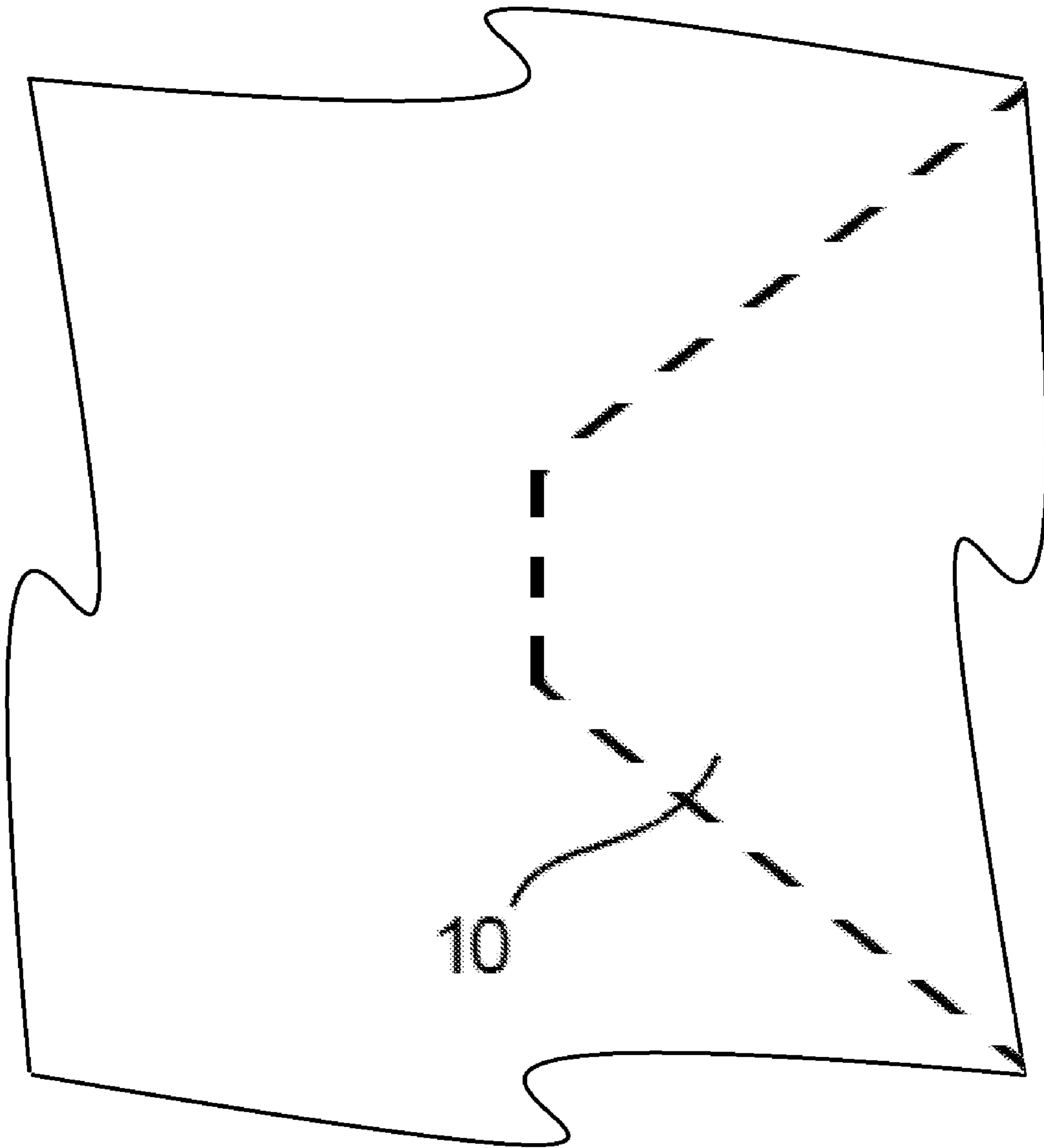

FIG 9

1**PANELS COMPRISING A MECHANICAL
LOCKING DEVICE AND AN ASSEMBLED
PRODUCT COMPRISING THE PANELS**

TECHNICAL FIELD

The present disclosure relates to panels that may be arranged perpendicular to each other and locked together with a mechanical locking device. The panels may be assembled and locked together to obtain a furniture product, such as a bookshelf, a cupboard, a wardrobe, a box, a drawer or a furniture component. The mechanical locking device may comprise a flexible tongue.

BACKGROUND

A furniture product provided with a mechanical locking device is known in the art, as evidenced by WO 2015/038059. The furniture product comprises a first panel connected perpendicular to a second panel by a mechanical locking device comprising a flexible tongue in an insertion groove.

SUMMARY

One object of certain embodiments of the present disclosure is to provide an improvement over the above described technique and the known art. A specific objective is to improve disassembling of panels, such as furniture panels, locked together by a mechanical locking device. The panels may be a part of a furniture product, such as a furniture component, a drawer, a cupboard, a bookshelf, a wardrobe, a kitchen fixture, and a box.

At least some of these and other objects and advantages that will be apparent from the description have been achieved by a first aspect of the present disclosure that includes a set of panels comprising a first panel having a first main plane and a second panel having a second main plane, wherein the first panel and the second panel comprise a locking device for locking a first edge of the first panel to a second edge of the second panel. The first main plane is essentially perpendicular to the second main plane in locked position of the first panel and the second panel. The locking device comprises an edge groove at the first edge and a tongue groove at the second edge. The edge groove comprises an insertion groove at a first side of the edge groove and a flexible tongue is arranged in the insertion groove. Said flexible tongue is configured to cooperate with the tongue groove for locking together the first edge and the second edge in a first direction, which is perpendicular to the first main plane. Said first side of the edge groove comprises a first groove surface at a first side of the insertion groove and a second groove surface at a second side of the insertion groove. A first side of said second edge comprises a first edge surface at a first side of the tongue groove and a second edge surface at a second side of the tongue groove. The first groove surface and the first edge surface are configured to cooperate for locking the first edge and the second edge in a second direction, which is perpendicular to the second main plane. The second groove surface and the second edge surface are configured to cooperate for locking the first edge and the second edge in the second direction. Said locking device is configured to be unlocked by inserting a tool in the tongue groove. The first groove surface is arranged offset in the second direction relative to the second groove surface by a first distance. This configuration may facilitate disassem-

2

bling of the first panel and the second panel since the tool may be easier to insert into the tongue groove.

The first edge surface may be arranged offset in the second direction relative to the second surface by a second distance, which is preferably essentially the same as the first distance.

The first distance is in the range of about 0.1 mm to about 0.4 mm. Preferably, the first distance is about 0.2 mm, such as within 10% of 0.2 mm.

The first groove surface and the first edge surface are preferably parallel and may extend parallel to the second main plane.

The second groove surface and the second edge surface are preferably parallel and may extend parallel to the second main plane.

The edge groove may comprise, at a second side that is opposite to the first side, a third groove surface, which is configured to cooperate with a third edge surface of the second edge for locking the first edge and the second edge in the second direction. The third groove surface and the third edge surface are preferably parallel and may extend parallel to the second main plane.

The first groove surface may be configured to extend partly over the tongue groove. This configuration may have the advantage that a part of the first groove surface which extends over the tongue groove may work as a guiding surface for the tool during an insertion of the tool into the tongue groove. This may also result in a larger tongue groove and a tool with a larger crosscut area. A larger crosscut area may have the effect of a stronger and stiffer tool, which may facilitate the insertion of the tool in the tongue groove.

The first edge surface may be a bottom surface of a recess at the second edge, and is positioned in a locked position of the first panel and the second panel adjacent a first side of an opening of the edge groove. A side surface of the recess may be configured to cooperate with a first main surface of the first panel.

The first edge surface may be at a first main surface of the second panel.

A bottom surface of the edge groove may be configured to cooperate with an outer edge surface of the second edge for locking in the first direction.

The locking device may comprise cooperating surfaces at a second side of the opening of the edge groove, preferably at an outer edge surface at an outer corner of the first panel and at the second panel, respectively, in a locked position.

The locking device may be configured such that a space is obtained between an outer surface of the tool and the first groove surface when the tool is inserted in the tongue groove. A play between the outer surface of the tool and the groove surface is preferably essentially the same as the first distance. For example, the play may be in the range of about 0.1 mm to about 0.4 mm, and may be about 0.2 mm, such as within 10% of 0.2 mm. The outer surface of the tool is preferably inline with the second edge surface when the tool is inserted into the tongue groove. The outer surface of the tool may alternatively be positioned, in the second direction, between the first edge surface and the second edge surface.

The locking device may comprise a bevel or rounding at an opening of the tongue groove. The bevel or rounding may further facilitate disassembling, as the bevel or the rounding may prevent that the flexible tongue from getting stuck during the disassembling, particularly for the case when the play is somewhat too small, such as less than 0.1 mm, due to production tolerances being too large.

3

A cross section of the tool may have essentially the same shape as a cross section of the tongue groove.

The locking device is preferably configured such that the flexible tongue moves out of the tongue groove when the tool is inserted into the tongue groove, and the flexible tongue is pushed back into the insertion groove.

The edge groove may have a length which is essentially the same as a width of the first panel.

A part of the second edge, which is configured to be inserted into the edge groove, may have a length which is essentially the same as a width of the second panel.

The flexible tongue may be displaceable in the insertion groove.

The first panel and the second panel are preferably configured to be assembled by displacing the first panel relative to the second panel in the first direction, wherein the first panel is perpendicular to the second panel. The second edge is inserted into the edge groove, wherein the flexible tongue is pushed back into the insertion groove and springs back into the tongue groove to obtain a locked position of the first panel and the second panel.

The flexible tongue may be designed according to the flexible tongue described and shown in FIGS. 2A-2F of WO2015/105449, which are hereby expressly incorporated by reference herein.

The insertion groove may have a length which is essentially the same as the length of the edge groove.

Some or all features that facilitate unlocking by may be combined in one embodiment to improve the unlocking.

The set of panels may be furniture panels.

A second aspect of the present disclosure includes a set of panels as described above and a tool configured to unlock the locking device by inserting the tool in the tongue groove.

A third aspect of the present disclosure includes an assembled furniture product comprising a corner of a frame comprising the set of panels as described above.

A core material of the first panel and/or the second panel may comprise a wood fibre based board, such as a HDF, MDF, plywood, solid wood or particleboard, or a reinforced plastic board or a wood fibre composite board.

The core may be provided with a decorative layer.

BRIEF DESCRIPTION OF THE DRAWINGS

Embodiments of the present disclosure will by way of example be described in more detail with reference to the appended schematic drawings, in which:

FIG. 1 shows an embodiment comprising the first panel and the second panel during unlocking with an embodiment of the tool inserted into an embodiment of the tongue groove.

FIG. 2 shows an enlarged view of the encircled area in FIG. 1.

FIG. 3A shows an embodiment comprising the first panel and the second panel in a locked position.

FIG. 3B shows a part of the first panel.

FIG. 4A shows a part of the second panel.

FIG. 4B shows an enlarged view of the encircled area in FIG. 4A.

FIG. 5 shows an embodiment comprising the first panel and the second panel during unlocking with an embodiment of the tool inserted into an embodiment of the tongue groove.

FIG. 6 shows an embodiment comprising the first panel and the second panel during unlocking with an embodiment of the tool inserted into an embodiment of the tongue groove.

4

FIG. 7 shows an embodiment comprising the first panel and the second panel in an unlocked position and before assembling.

FIGS. 8A-8F show embodiments of the flexible tongue.

FIG. 9 shows an embodiment of a section of a front portion of a furniture product.

DETAILED DESCRIPTION

FIG. 1 shows a disassembling of a first panel 6 from a second panel 4. The first panel 6 and the second panel 4 are provided with an embodiment of a locking device 60. The first panel 6 may be a top panel of a frame, such as a frame for a furniture product, and the second panel 4 may be a side panel of the frame. FIG. 2 shows an enlarged view of a part of the locking device 60 in a position during unlocking of the first panel 6 and the second panel 4.

The first panel 6 has a first main plane and second panel 4 has a second main plane. The first main plane is essentially perpendicular to the second main plane. The locking device 60 is configured for locking a first edge of the first panel 6 to a second edge of the second panel 4, as shown in FIG. 3A. The locking device 60 comprises an edge groove 21 at the first edge and a tongue groove 10 at the second edge. The edge groove 21 comprises a flexible tongue 30 arranged in an insertion groove 20 at a first side of the edge groove 21, said flexible tongue is configured to cooperate with the tongue groove 10 for locking together the first edge and the second edge in a first direction D1 which is perpendicular to the first main plane. The first side of the edge groove 21 comprises a first groove surface 51 at a first side of the insertion groove 20 and a second groove surface 53 at a second side of the insertion groove 20, wherein the first groove surface 51 is closer to an opening of the edge groove 21 than the second groove surface 53. A first side of said second edge comprises a first edge surface 52 at a first side of the tongue groove 10 and a second edge surface 54 at a second side of the tongue groove 10. The first groove surface 51 and the first edge surface 52 are configured to cooperate for locking the first edge and the second edge in a second direction D2, which is perpendicular to the second main plane. The second groove surface 53 and the second edge surface 54 are configured to cooperate for locking the first edge and the second edge in the second direction D2.

Said locking device 60 is configured to be unlocked by inserting a tool 90 in the tongue groove 10.

The tool 90 is configured to unlock the locking device 60 by pushing the flexible tongue 30 out of the tongue groove 10 and towards a bottom of the insertion groove 20.

The tool 90 may be of an elongated shape, and FIG. 1 shows a crosscut of such a tool 90.

The first panel 6 and the second panel 4 may be a part of a furniture product, such as a frame. The tongue groove 10 may have an insertion opening at a backside of the furniture product, such that the tool 90 may be inserted in said insertion opening, and the tongue groove 10 may be covered at, or does not extend to, a front side of the furniture product. The insertion groove 20 may be positioned at other parts of the furniture product.

Said first groove surface 51 is arranged offset in the second direction D2 relative to the second groove surface 53 by a first distance 41 (see FIG. 3B). FIG. 2 shows an enlarged view of the encircled area in FIG. 1.

The first groove surface 51 and the first edge surface 52 may be parallel and preferably extend parallel to the second main plane. The second groove surface 53 and the second

5

edge surface 54 may be parallel and preferably extend parallel to the second main plane.

The edge groove 21 may comprise, at a second side that is opposite to the first side, a third groove surface 55, which is configured to cooperate with a third edge surface 56 for locking the first edge and the second edge in the second direction D2.

The locking device 60 may comprise cooperating surfaces 45, 46 at a second side of the opening of the edge groove 21, preferably at an outer edge surface at an outer corner of the first panel and the second panel, respectively, in a locked position of the first panel and the second panel.

The first edge surface 52 may be a bottom surface of a recess 44 at the second edge. In a locked position of the first panel 6 and the second panel 4, the bottom surface is adjacent a first side 43 of an opening of the edge groove 21. A side surface of the recess 44 may be configured to cooperate with a first main surface 18 of the first panel 6.

FIG. 2 shows an embodiment of the first groove surface 51 which extends partly over the tongue groove 10. The locking device 60 is configured such that a play 40 is obtained between an outer surface 91 of the tool 90 and the first groove surface 51 when the tool 90 is inserted in the tongue groove 10. The tool 90 may have essentially the same shape as a cross section of the tongue groove 10. The outer surface of the tool 90 is preferably in line with the second edge surface 54 when the tool 90 is inserted into the tongue groove 10. The outer surface of the tool 90 may alternatively be positioned, in the second direction D2, between the first edge surface 52 and second edge surface 54.

The first panel 6 and the second panel 4 each preferably comprises four edges, a first main surface 18, 17 and a second main surface 16, 15. The first main plane is parallel to the first main surface 18 and the second main surface 16 of the first panel 6, and the second main plane is parallel to the first main surface 17 and the second main surface 15 of the second panel 4. FIG. 1 shows an embodiment wherein the first main surface 17 of the second panel 4 is arranged at an essentially perpendicular angle 5 to the first main surface 18 of the first panel 6. The first main surface 17 of the second panel 4 preferably faces the first main surface 18 of the first panel 6.

The first main surfaces 18, 16 and/or the second main surfaces 17, 15 may comprise a decorative layer (not shown).

The flexible tongue 30 is preferably displaceable in the insertion groove 20. The flexible tongue 30 and the insertion groove 20 may be designed according to the flexible tongue and the groove described and shown in FIGS. 2A-2F in WO2015/105449.

FIG. 3A shows an embodiment of the first panel 6 and the second panel 4 in a locked position. The flexible tongue 30 cooperates with the tongue groove 10 for locking the first panel 6 and the second panel 4 together.

FIG. 3B shows an embodiment of the first edge. The first groove surface 51 is arranged offset in the second direction D2 relative to the second groove surface 53 by a first distance 41. The first distance 41 may be in the range of about 0.1 mm to about 0.4 mm. Preferably, the first distance is about 0.2 mm.

FIG. 4A shows an embodiment of the second edge. The first edge surface 52 is arranged offset in the second direction D2 relative to the second edge surface 54 by a second distance 42. The second distance 42 may be in the range of about 0.1 mm to about 0.4 mm. Preferably, the first distance is about 0.2 mm. The second distance 42 is preferably

6

essentially equal to as the first distance 41. The play 40 shown in FIG. 2 is preferably essentially equal to the first distance 41,

FIG. 4B shows an enlarged view of the encircled area in FIG. 4A. FIG. 4B shows an embodiment of the locking device 60 comprising a bevel or rounding 47 at an opening of the tongue groove 10.

FIG. 5 and FIG. 6 show embodiments wherein the first edge surface 52 is at the first main surface 17 of the second panel 4. A bottom surface 23 of the edge groove 21 may be configured to cooperate with an outer edge surface 24 of a portion 22 of the second edge for locking in the first direction D1.

FIG. 6 shows an embodiment comprising a first panel 6 extending beyond the second main surface 15 of the second panel 4. An outer edge 14 of the first panel 6 is positioned at a distance from the second main surface 15 of the second panel 4. This may be an advantage for embodiments in which the first edge surface 52 is a part of a surface that has not been worked. This may have the advantage that there is an overlap between the first panel 6 and the second panel 4, at an outer corner, even in the event that the first panel 6 is too thin, due to production tolerances being too large in the panel production.

FIG. 7 shows in a 3D-view an embodiment before the first panel 6 and the second panel 4 are assembled and locked together. The edge groove 21 extends along the first edge of the first panel 6 and in a third direction D3 which is perpendicular to the first direction D1 and the second direction D2. The tongue groove 21 extends along the second edge of the first panel 4.

An embodiment of the flexible tongue 30, which is displaceable in an insertion groove 20, is shown in FIGS. 8A-8D. FIGS. 8A-8B show the flexible tongue 30 in a locked position and FIGS. 8C-8D show the flexible tongue 30 during assembling of the first panel 6 and the second panel 4. FIG. 8B shows a cross section of the flexible tongue 30 illustrated in FIG. 8A. FIG. 8D shows a cross section of the flexible tongue 30 illustrated in FIG. 8C. The flexible tongue 30 comprises bendable protruding parts 84. A space 83 is provided between the flexible tongue 30 and a bottom wall of the insertion groove 20. FIG. 8C shows that the flexible tongue 30 is pushed into the insertion groove 20 and towards the bottom wall of the insertion groove 20 during an assembly of the first panel 6 with the second panel 4. The flexible tongue 30 springs back toward its initial position when the first panel 6 and the second panel 4 have reached a locked position. A recess 85 is preferably arranged at each bendable protruding part 84.

The flexible tongue 30 may have a first displacement surface 86 and an opposite second displacement surface 87, configured to be displaced along a third displacement surface 88 and a fourth displacement locking surface 89, respectively, of the insertion groove 20.

An alternative embodiment of the flexible tongue 30, without the protruding bendable parts 84, is shown in FIGS. 8E-8F. FIG. 8F shows a cross section of the flexible tongue 30 shown in FIG. 8E. The alternative embodiment is bendable in its length direction in order to accomplish the same function as the embodiment shown in FIGS. 8A-8D.

FIG. 9 shows an embodiment of a section of a front portion of a furniture product, wherein the tongue groove 10 is covered at the front side of the furniture product and/or does not extend to the front side of the furniture product.

The set of panels described above may be a part of a furniture product, such as a frame.

7

A core material of the panels in the embodiments above preferably comprises a wood fibre based board, such as a HDF, MDF, plywood, solid wood or particleboard, a reinforced plastic board, or a wood fibre composite board.

The invention claimed is:

1. A furniture product comprising a first panel having a first main plane and a second panel having a second main plane at a corner of the furniture product, wherein the first panel and the second panel comprise a locking device for locking a first edge of the first panel to a second edge of the second panel, wherein the first main plane is essentially perpendicular to the second main plane in a locked position of the first panel and the second panel, the locking device comprising an edge groove at the first edge and a tongue groove at the second edge, the edge groove comprising an insertion groove at a first side of the edge groove,

wherein the insertion groove comprises a flexible tongue which is configured to cooperate with the tongue groove for locking together the first edge and the second edge in a first direction which is perpendicular to the first main plane, said first side of the edge groove comprising a first groove surface at a first side of the insertion groove and a second groove surface at a second side of the insertion groove, and a first side of said second edge comprising a first edge surface at a first side of the tongue groove and a second edge surface at a second side of the tongue groove,

8

wherein the first groove surface and the first edge surface are configured to cooperate for locking the first edge and the second edge in a second direction, which is perpendicular to the second main plane,

wherein the second groove surface and the second edge surface are configured to cooperate for locking the first edge and the second edge in the second direction, said locking device is configured to be unlocked by inserting a tool in the tongue groove,

wherein the first groove surface is arranged offset in the second direction relative to the second groove surface by a first distance.

2. The furniture product as claimed in claim 1, wherein the tongue groove includes an insertion opening at a backside of the furniture product, such that the tool may be inserted in said insertion opening, the backside of the furniture product including a surface perpendicular to the first and second main planes.

3. The furniture product as claimed in claim 2, wherein the tongue groove is covered at a front side of the furniture product opposite the backside.

4. The furniture product as claimed in claim 2, wherein the tongue groove does not extend to a front side of the furniture product opposite the backside.

* * * * *