



US010650069B2

(12) **United States Patent**
Blank, Jr. et al.

(10) **Patent No.:** **US 10,650,069 B2**
(45) **Date of Patent:** ***May 12, 2020**

(54) **PREVIEWING RAW DATA PARSING**

(71) Applicant: **Splunk Inc.**, San Francisco, CA (US)

(72) Inventors: **Mitchell Neuman Blank, Jr.**, San Francisco, CA (US); **Leonid Budchenko**, San Jose, CA (US); **David Carasso**, San Rafael, CA (US); **Micah James Delfino**, San Francisco, CA (US); **Johnvey Hwang**, San Francisco, CA (US); **Stephen Phillip Sorkin**, San Francisco, CA (US); **Eric Timothy Woo**, San Francisco, CA (US)

(73) Assignee: **SPLUNK INC.**, San Francisco, CA (US)

(*) Notice: Subject to any disclaimer, the term of this patent is extended or adjusted under 35 U.S.C. 154(b) by 377 days.

This patent is subject to a terminal disclaimer.

(21) Appl. No.: **15/642,062**

(22) Filed: **Jul. 5, 2017**

(65) **Prior Publication Data**

US 2017/0300585 A1 Oct. 19, 2017

Related U.S. Application Data

(63) Continuation of application No. 15/224,655, filed on Jul. 31, 2016, now Pat. No. 9,740,788, which is a (Continued)

(51) **Int. Cl.**

G06F 16/00 (2019.01)

G06F 16/9535 (2019.01)

(Continued)

(52) **U.S. Cl.**

CPC **G06F 16/9535** (2019.01); **G06F 3/0482** (2013.01); **G06F 3/0485** (2013.01);

(Continued)

(58) **Field of Classification Search**

CPC .. G06F 16/9535; G06F 16/248; G06F 16/252; G06F 16/316; G06F 16/951;

(Continued)

(56) **References Cited**

U.S. PATENT DOCUMENTS

5,781,772 A 7/1998 Wilkinson, III et al.

6,011,795 A 1/2000 Varghese et al.

(Continued)

OTHER PUBLICATIONS

Carasso, D., "Exploring Splunk: Search Processing Language (SPL) Primer and Cookbook," Splunk, Apr. 2012.

(Continued)

Primary Examiner — Anh Ly

(74) *Attorney, Agent, or Firm* — Shook, Hardy & Bacon, L.L.P.

(57) **ABSTRACT**

Embodiments are directed towards previewing results generated from indexing data raw data before the corresponding index data is added to an index store. Raw data may be received from a preview data source. After an initial set of configuration information may be established, the preview data may be submitted to an index processing pipeline. A previewing application may generate preview results based on the preview index data and the configuration information. The preview results may enable previewing how the data is being processed by the indexing application. If the preview results are not acceptable, the configuration information may be modified. The preview application enables modification of the configuration information until the generated preview results may be acceptable. If the configuration information is acceptable, the preview data may be processed and indexed in one or more index stores.

20 Claims, 9 Drawing Sheets

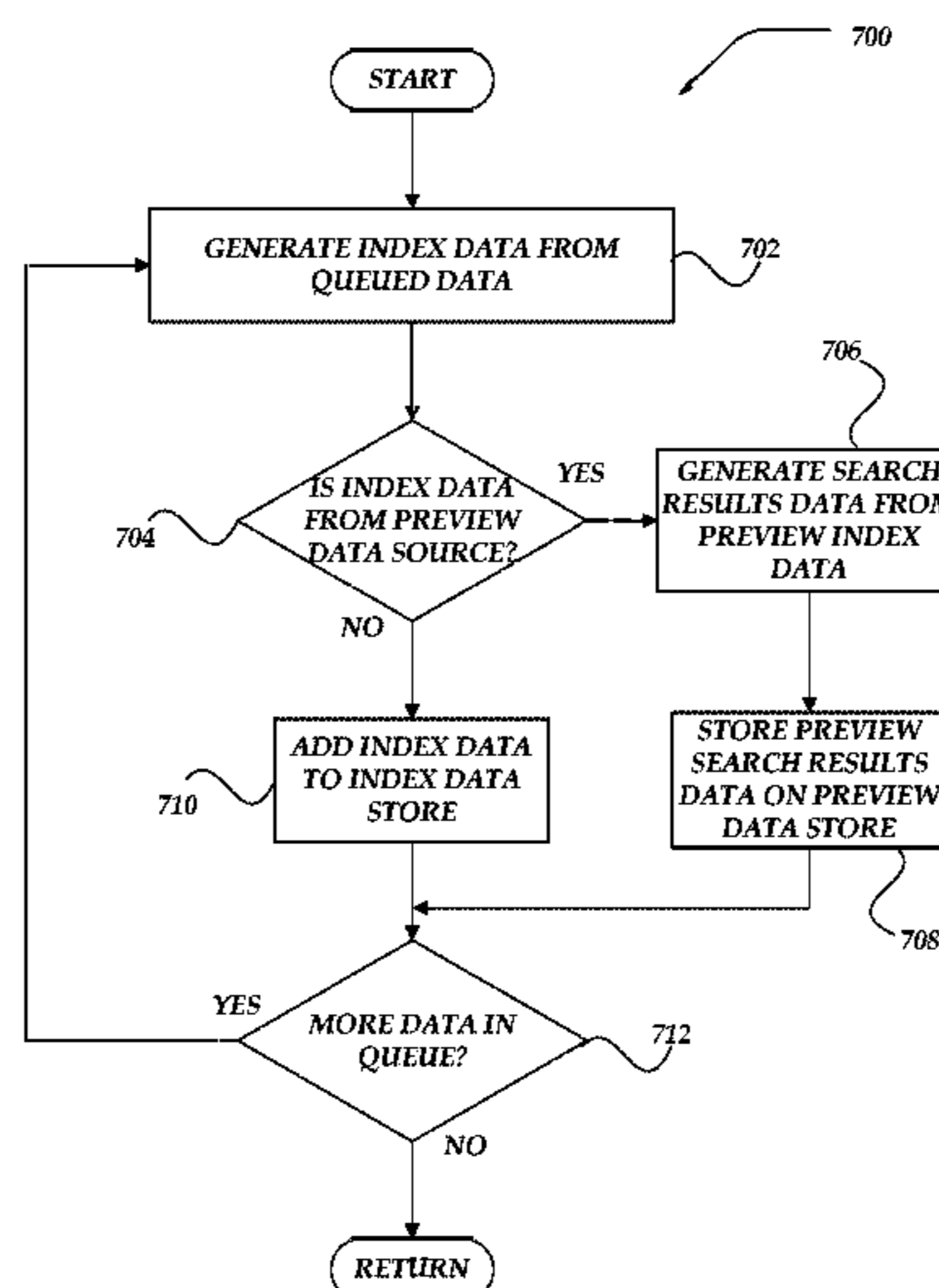

Related U.S. Application Data

continuation of application No. 14/929,332, filed on Oct. 31, 2015, now Pat. No. 9,442,981, which is a continuation of application No. 14/445,001, filed on Jul. 28, 2014, now Pat. No. 9,208,206, which is a continuation of application No. 13/588,939, filed on Aug. 17, 2012, now Pat. No. 8,825,664.

(51) **Int. Cl.**

G06F 16/248 (2019.01)
G06F 16/25 (2019.01)
G06F 16/31 (2019.01)
G06F 16/951 (2019.01)
G06F 16/22 (2019.01)
G06F 16/2458 (2019.01)
G06F 16/2455 (2019.01)
G06F 40/205 (2020.01)
G06F 3/0484 (2013.01)
G06F 3/0482 (2013.01)
G06F 3/0485 (2013.01)

(52) **U.S. Cl.**

CPC **G06F 3/04842** (2013.01); **G06F 16/2228** (2019.01); **G06F 16/248** (2019.01); **G06F 16/2477** (2019.01); **G06F 16/24564** (2019.01); **G06F 16/252** (2019.01); **G06F 16/316** (2019.01); **G06F 16/951** (2019.01); **G06F 40/205** (2020.01)

(58) **Field of Classification Search**

CPC G06F 16/2228; G06F 16/2477; G06F 16/24564; G06F 16/00; G06F 3/04842; G06F 3/0482; G06F 3/0485; G06F 17/2705; G06F 17/30; G06F 16/2372; G06F 16/9024; G06F 16/9027; G06F 17/30958; G06F 17/30374; G06F 17/50
 See application file for complete search history.

(56) **References Cited**

U.S. PATENT DOCUMENTS

6,052,683 A 4/2000 Irwin et al.
 6,067,574 A 5/2000 Tzeng et al.
 6,147,976 A 11/2000 Shand et al.
 6,212,184 B1 4/2001 Venkatachary et al.
 6,446,081 B1 9/2002 Preston
 6,567,408 B1 5/2003 Li et al.
 6,718,535 B1 4/2004 Underwood
 6,836,894 B1 12/2004 Hellerstein et al.
 7,272,589 B1 9/2007 Guay et al.
 7,743,060 B2 6/2010 Fontoura et al.
 8,102,869 B2 1/2012 Brown et al.
 8,380,752 B2 2/2013 Botros et al.
 8,572,483 B1* 10/2013 DiLorenzo G06F 3/0481
 715/273
 9,442,981 B2 9/2016 Blank, Jr. et al.
 2003/0050805 A1* 3/2003 Gouyet G06Q 10/02
 705/5
 2004/0230667 A1 11/2004 Wookey
 2005/0022207 A1 1/2005 Grabarnik et al.
 2005/0049924 A1* 3/2005 DeBettencourt H04L 43/028
 705/21
 2005/0060340 A1 3/2005 Sommerfield et al.
 2006/0124738 A1 6/2006 Wang et al.
 2007/0011353 A1* 1/2007 Hicks G06F 17/278
 709/245
 2007/0118491 A1 5/2007 Baum et al.
 2007/0185859 A1 8/2007 Flowers et al.
 2008/0039121 A1 2/2008 Muller et al.
 2008/0172409 A1 7/2008 Botros et al.
 2008/0215546 A1 9/2008 Baum et al.

2008/0294588 A1 11/2008 Morris et al.
 2009/0150769 A1 6/2009 Konnola et al.
 2009/0157513 A1 6/2009 Bonev et al.
 2009/0182779 A1* 7/2009 Johnson G06F 16/2393
 707/E17.005
 2010/0057556 A1* 3/2010 Rousso G06Q 30/02
 705/14.44
 2010/0064026 A1 3/2010 Brown et al.
 2010/0228650 A1 9/2010 Shacham et al.
 2010/0250566 A1 9/2010 Paul
 2010/0318858 A1 12/2010 Essawi et al.
 2011/0035390 A1 2/2011 Whitehouse
 2011/0110515 A1* 5/2011 Tidwell H04N 21/23109
 380/200
 2011/0173180 A1 7/2011 Gurumurthy et al.
 2011/0191679 A1 8/2011 Lin et al.
 2011/0296244 A1 12/2011 Fu et al.
 2012/0023116 A1 1/2012 Wilkes et al.
 2012/0050778 A1 3/2012 Shiohara
 2012/0072204 A1 3/2012 Nasri et al.
 2012/0078951 A1 3/2012 Hsu et al.
 2012/0109637 A1 5/2012 Merugu et al.
 2012/0117015 A1 5/2012 Sathish
 2012/0197914 A1 8/2012 Harnett et al.
 2012/0197928 A1* 8/2012 Zhang G06F 16/2471
 707/769
 2012/0197934 A1* 8/2012 Zhang G06F 16/24568
 707/770
 2012/0203757 A1 8/2012 Ravindran
 2012/0265726 A1* 10/2012 Padmanabhan G06F 16/214
 707/602
 2012/0303561 A1* 11/2012 Sathish G06Q 30/0282
 706/14
 2013/0166332 A1* 6/2013 Hammad G06Q 40/10
 705/5
 2013/0204894 A1* 8/2013 Faith G06Q 30/0631
 707/769
 2013/0290106 A1* 10/2013 Bradley G06Q 90/20
 705/14.64
 2014/0040287 A1 2/2014 Frome
 2014/0052733 A1* 2/2014 Blank, Jr. G06F 3/04842
 707/741
 2014/0149477 A1 5/2014 Abramovitz et al.
 2014/0337354 A1* 11/2014 Blank, Jr. G06F 3/04842
 707/741

OTHER PUBLICATIONS

Non-Final Office Action dated Jan. 8, 2013 in U.S. Appl. No. 13/588,939, 8 pages.
 Non-Final Office Action dated Jan. 8, 2013 in U.S. Appl. No. 13/662,337, 8 pages.
 Notice of Allowance dated Apr. 25, 2013 in U.S. Appl. No. 13/588,939, 7 pages.
 Notice of Allowance dated Apr. 29, 2013 in U.S. Appl. No. 13/662,337, 7 pages.
 Non-Final Office Action dated Mar. 7, 2014 in U.S. Appl. No. 13/588,939, 10 pages.
 Notice of Allowance dated Jun. 4, 2014 in U.S. Appl. No. 13/588,939, 7 pages.
 Non-Final Office Action dated Feb. 2, 2015 in U.S. Appl. No. 14/445,001, 21 pages.
 Notice of Allowance dated Sep. 21, 2015 in U.S. Appl. No. 14/445,001, 30 pages.
 Non-Final Office Action dated Feb. 11, 2016 in U.S. Appl. No. 14/929,332, 22 pages.
 Notice of Allowance dated Jul. 1, 2016 in U.S. Appl. No. 14/929,332, 11 pages.
 Non-Final Office Action dated Oct. 14, 2016 in U.S. Appl. No. 15/224,655, 21 pages.
 Notice of Allowance dated Apr. 5, 2017 in U.S. Appl. No. 15/224,655, 12 pages.

* cited by examiner

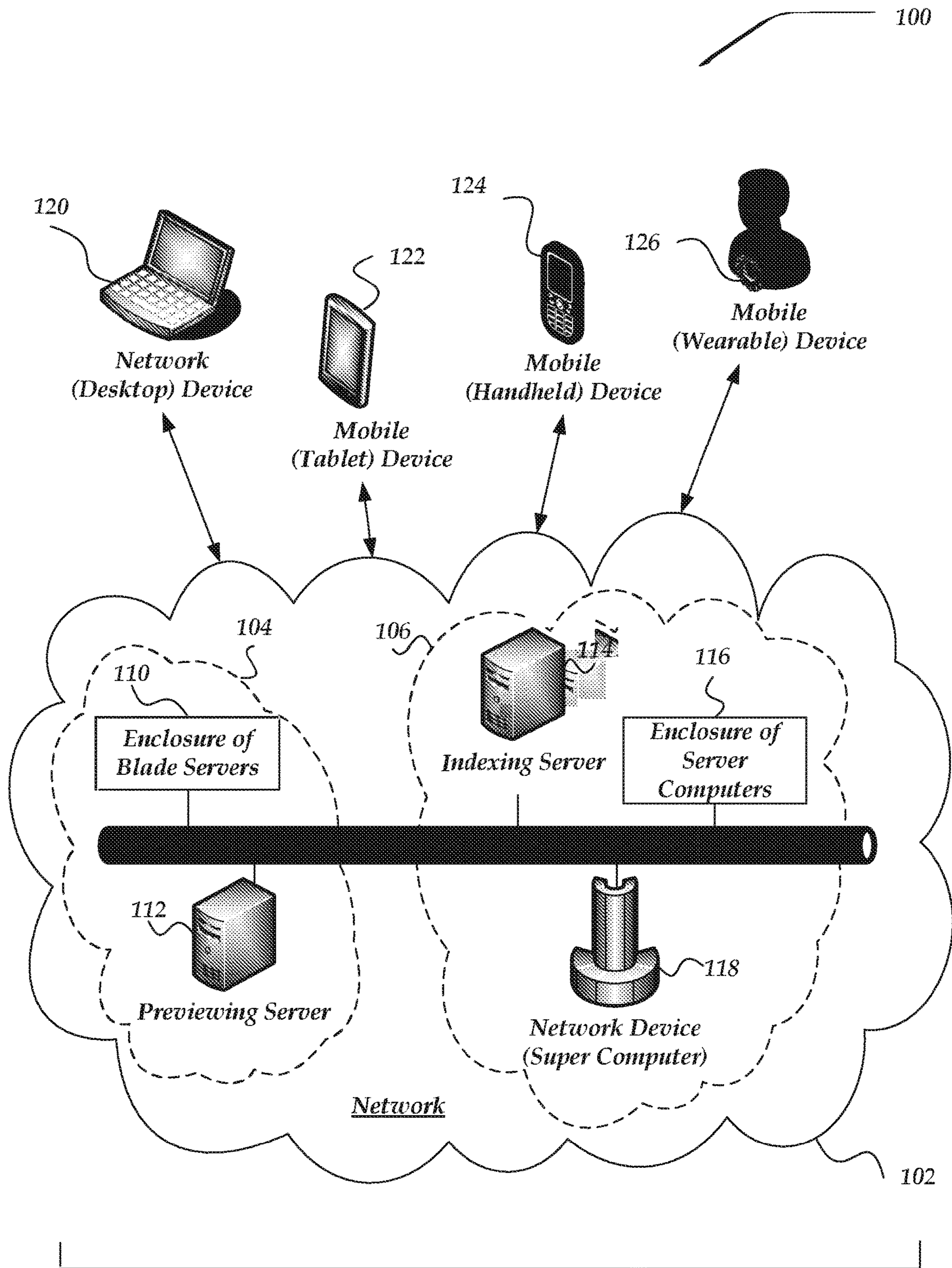

Fig. 1

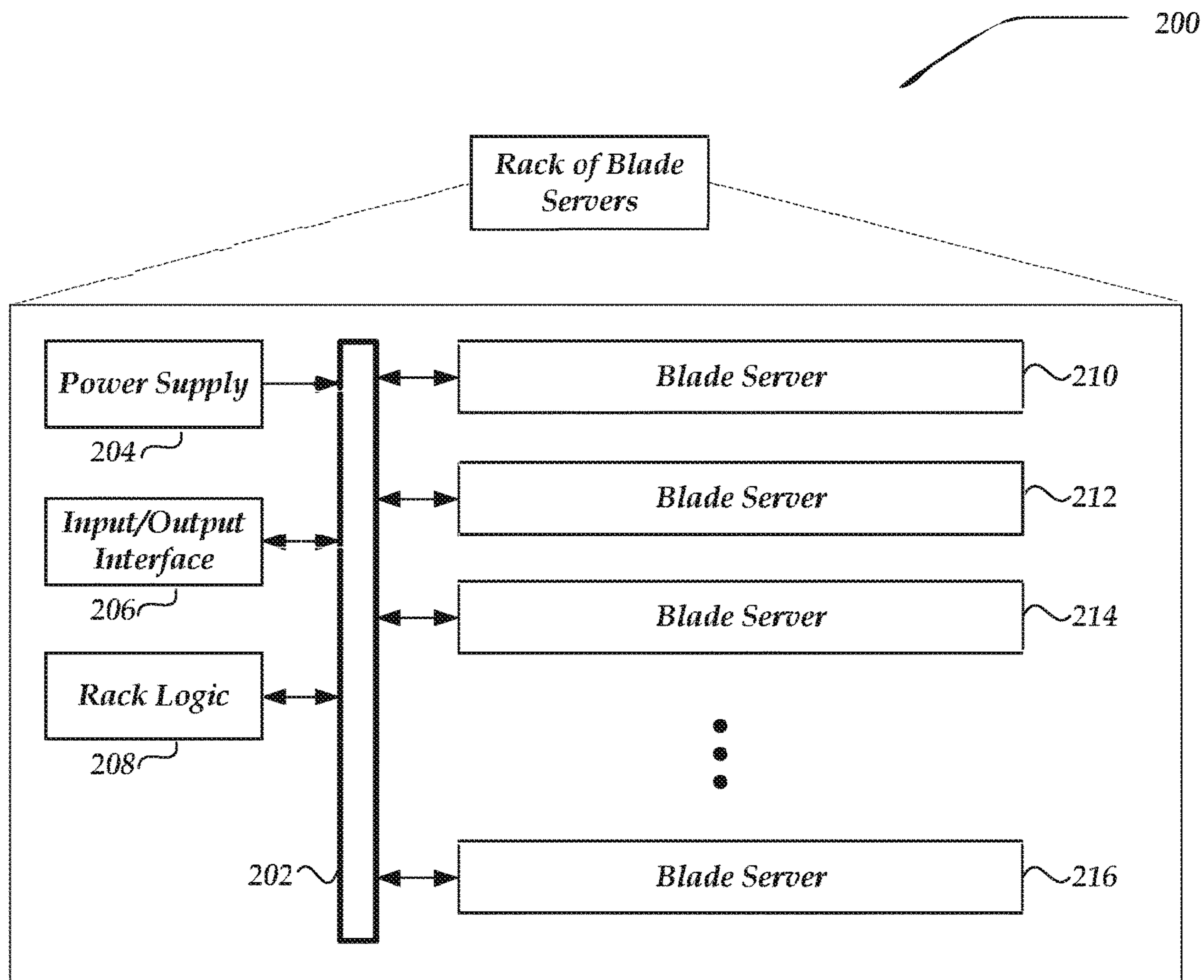

Fig. 2A

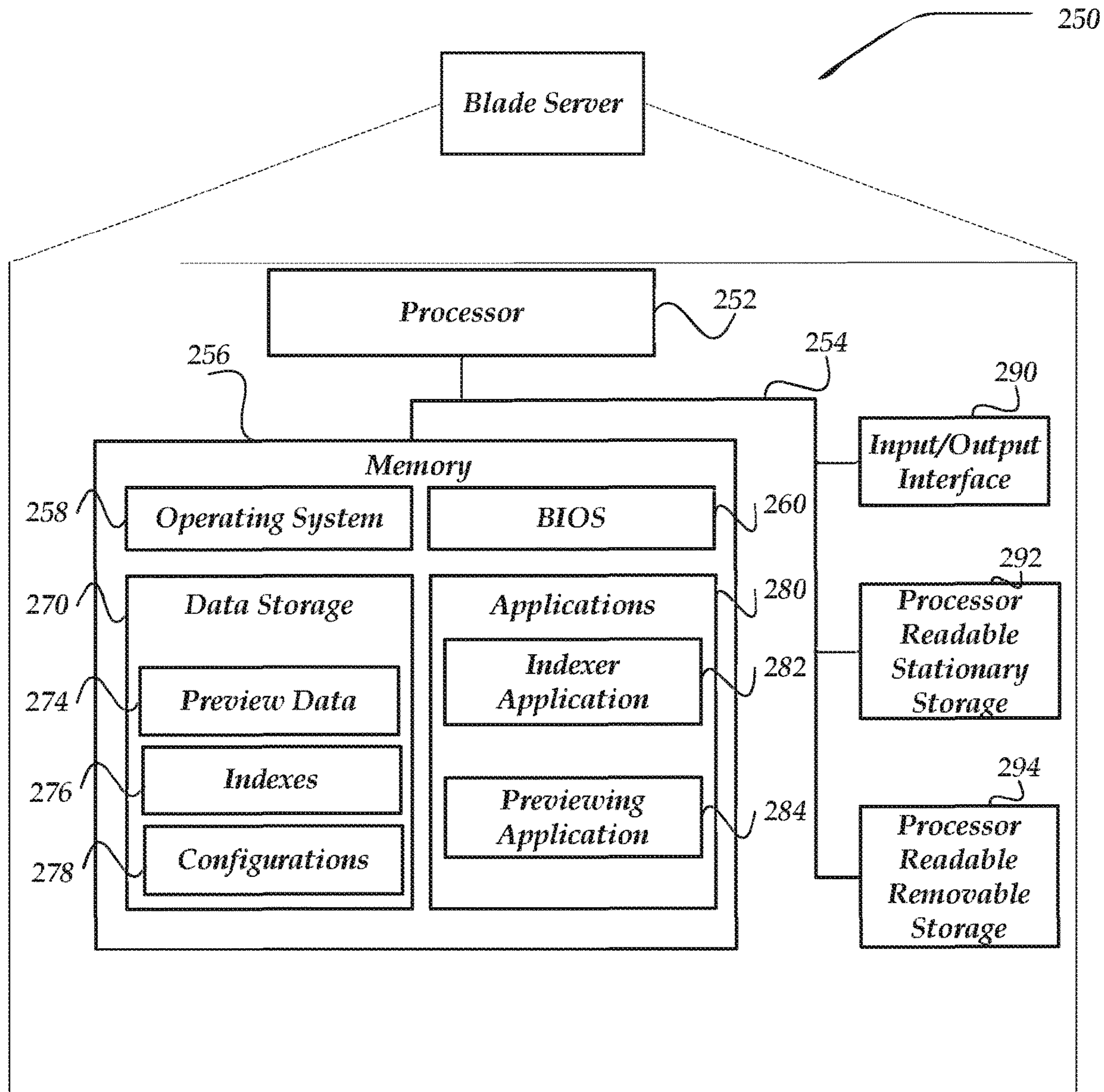

Fig. 2B

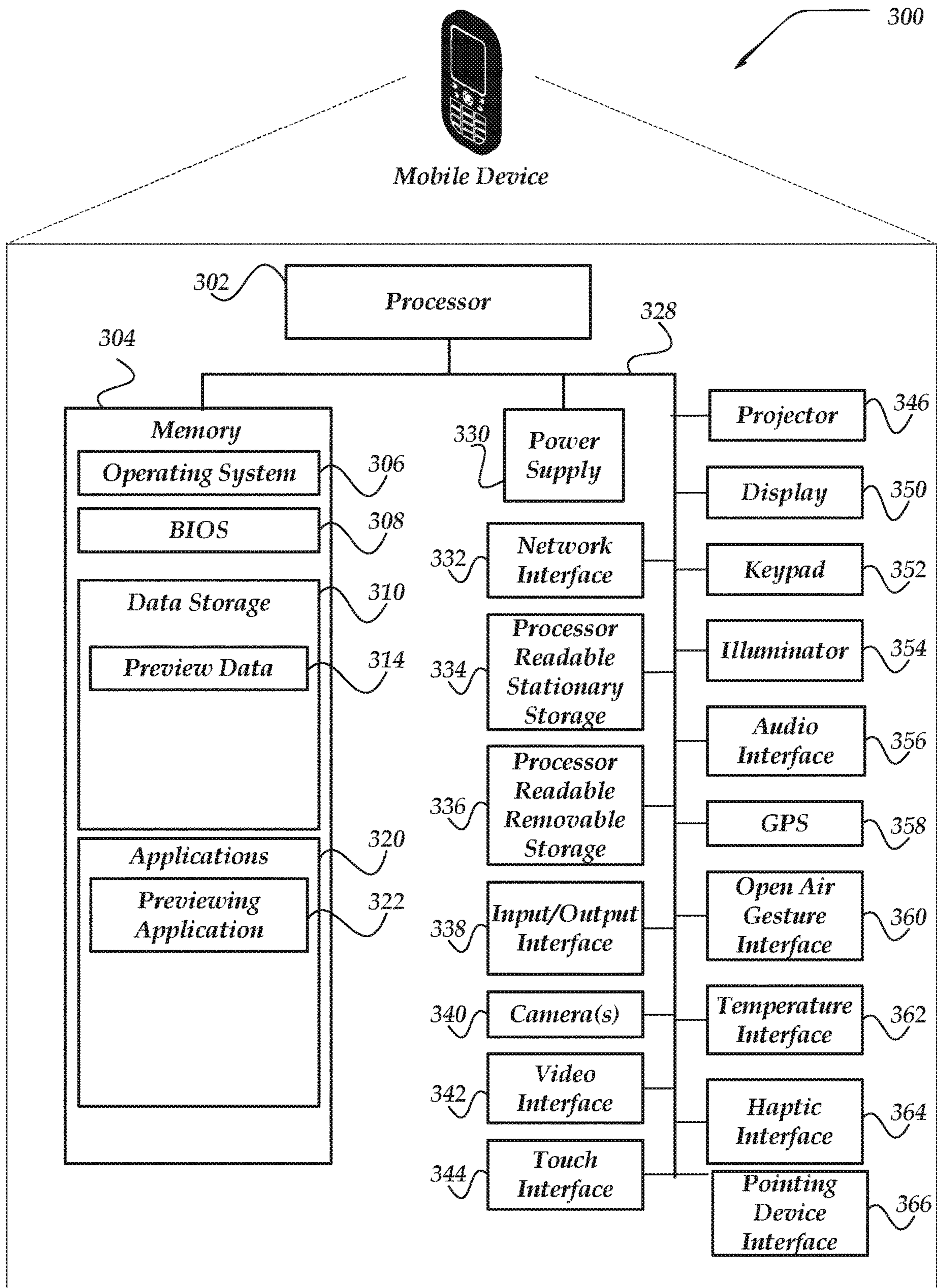

Fig. 3

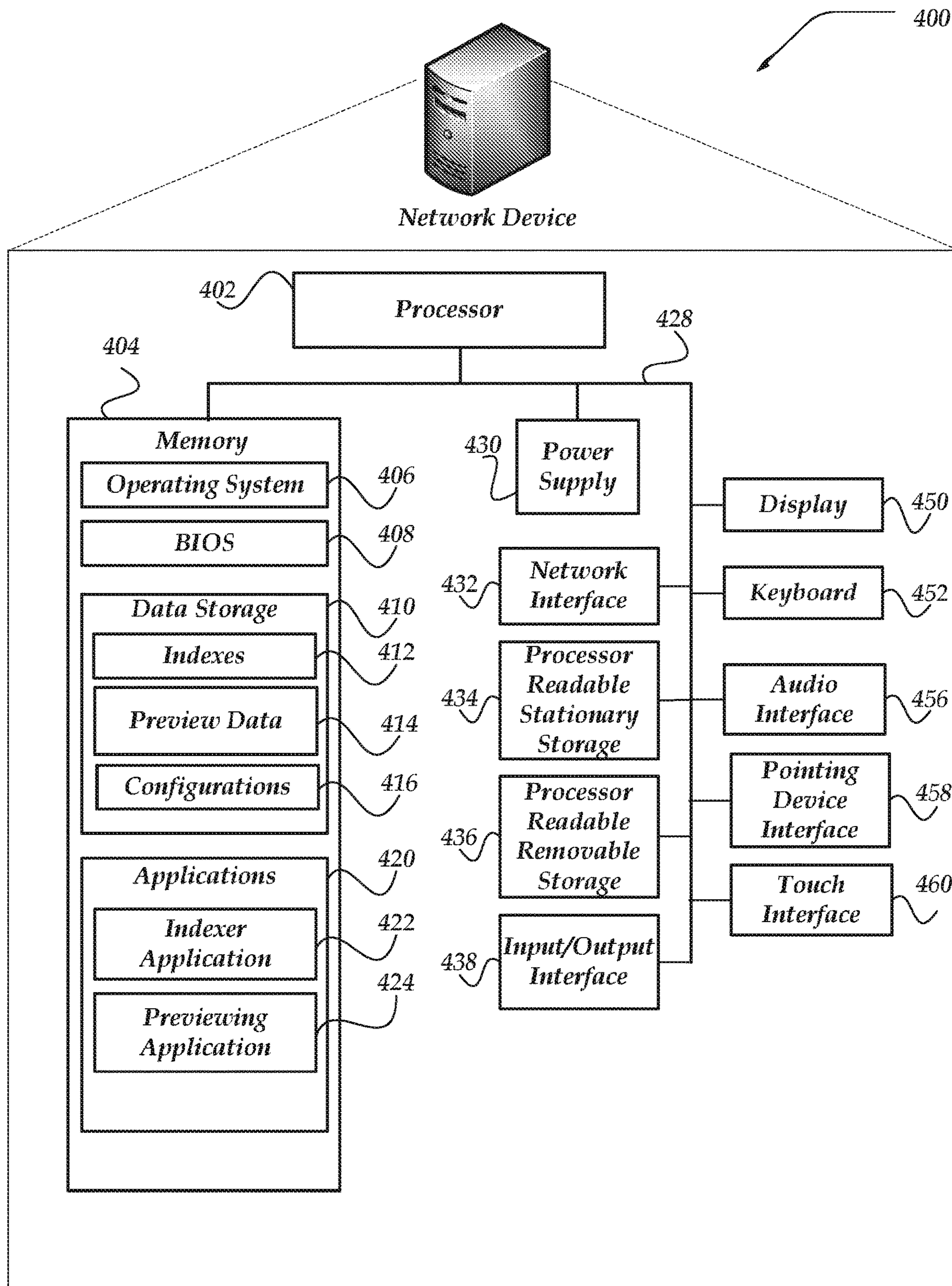

Fig. 4

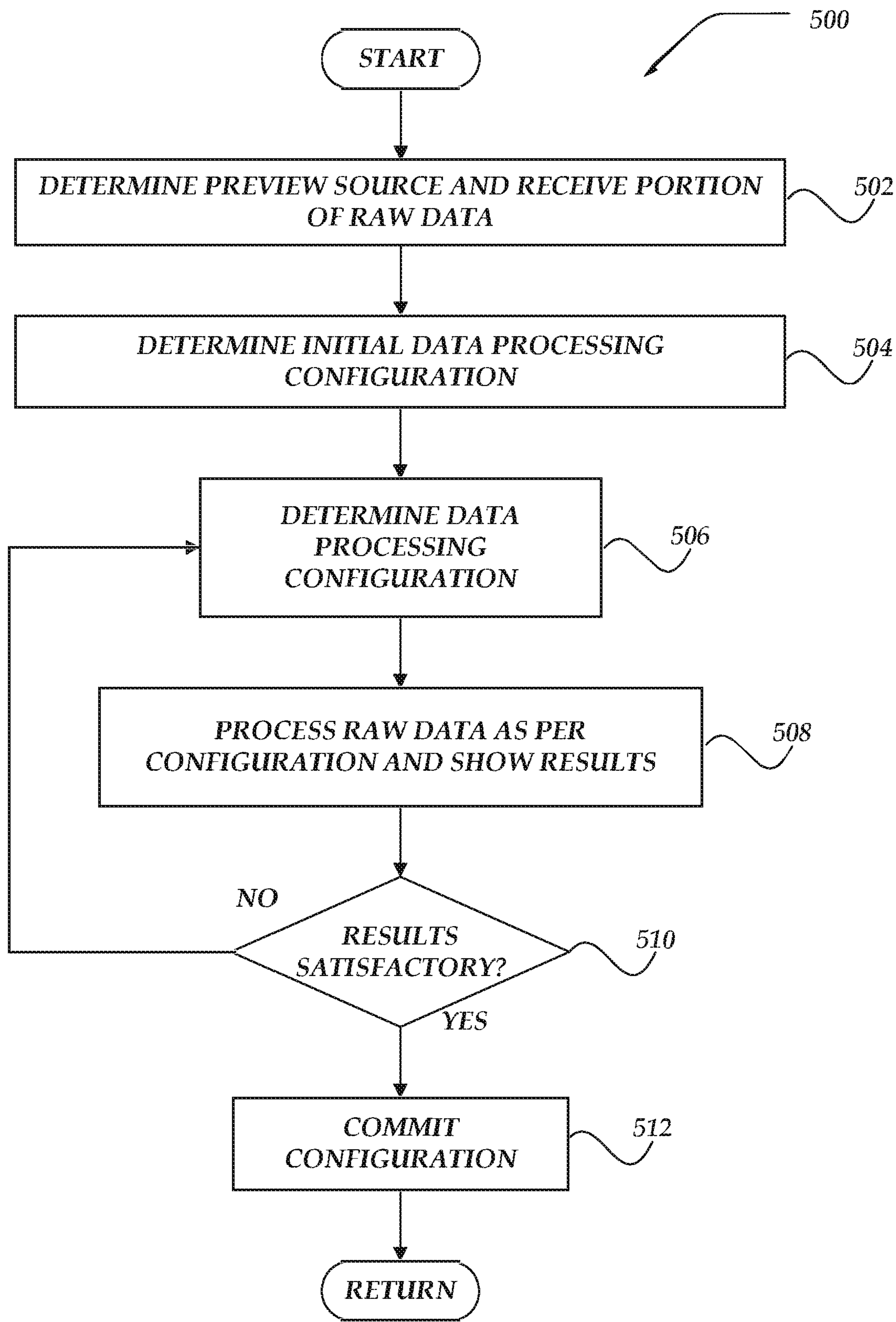

Fig. 5

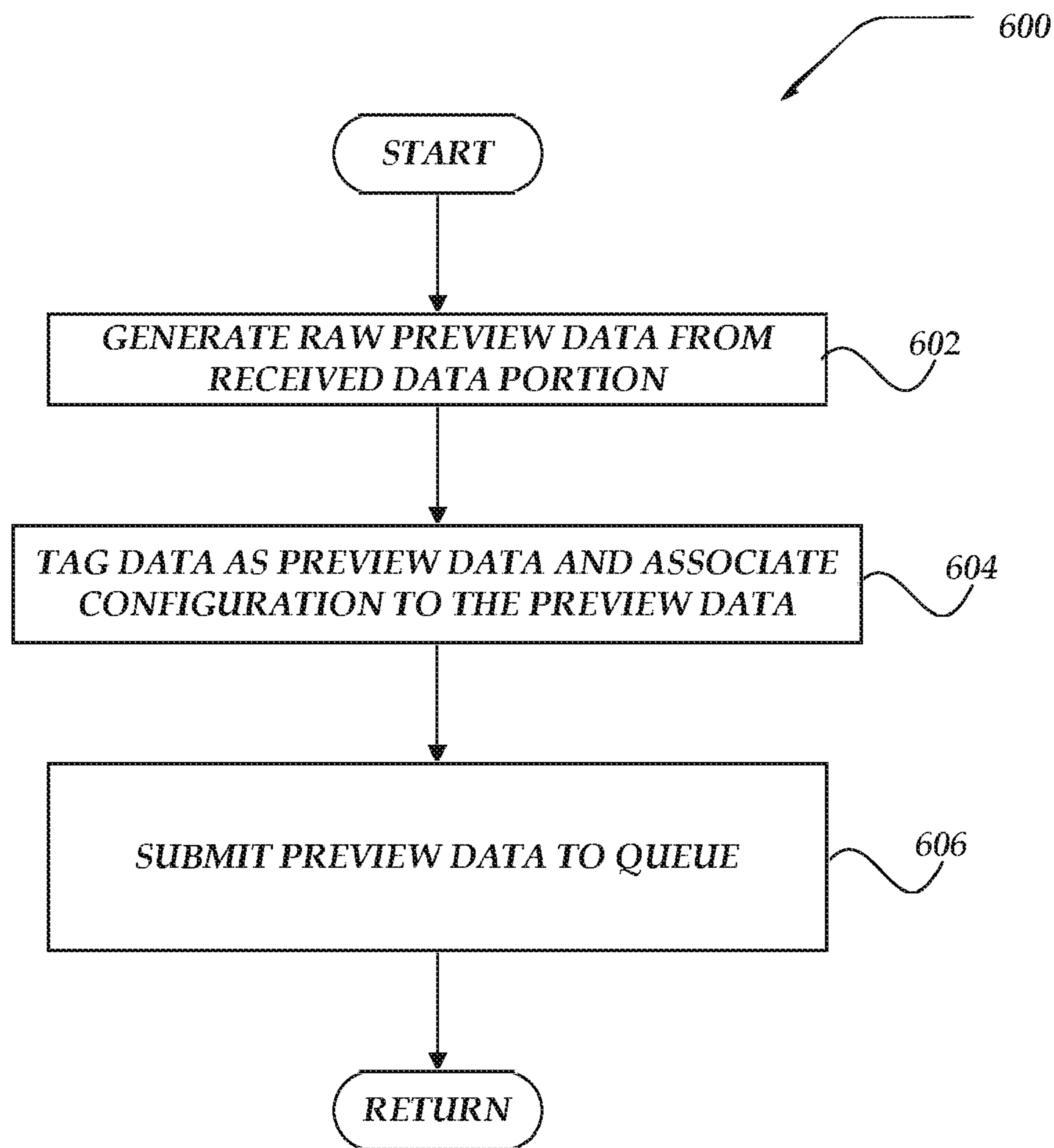

Fig. 6

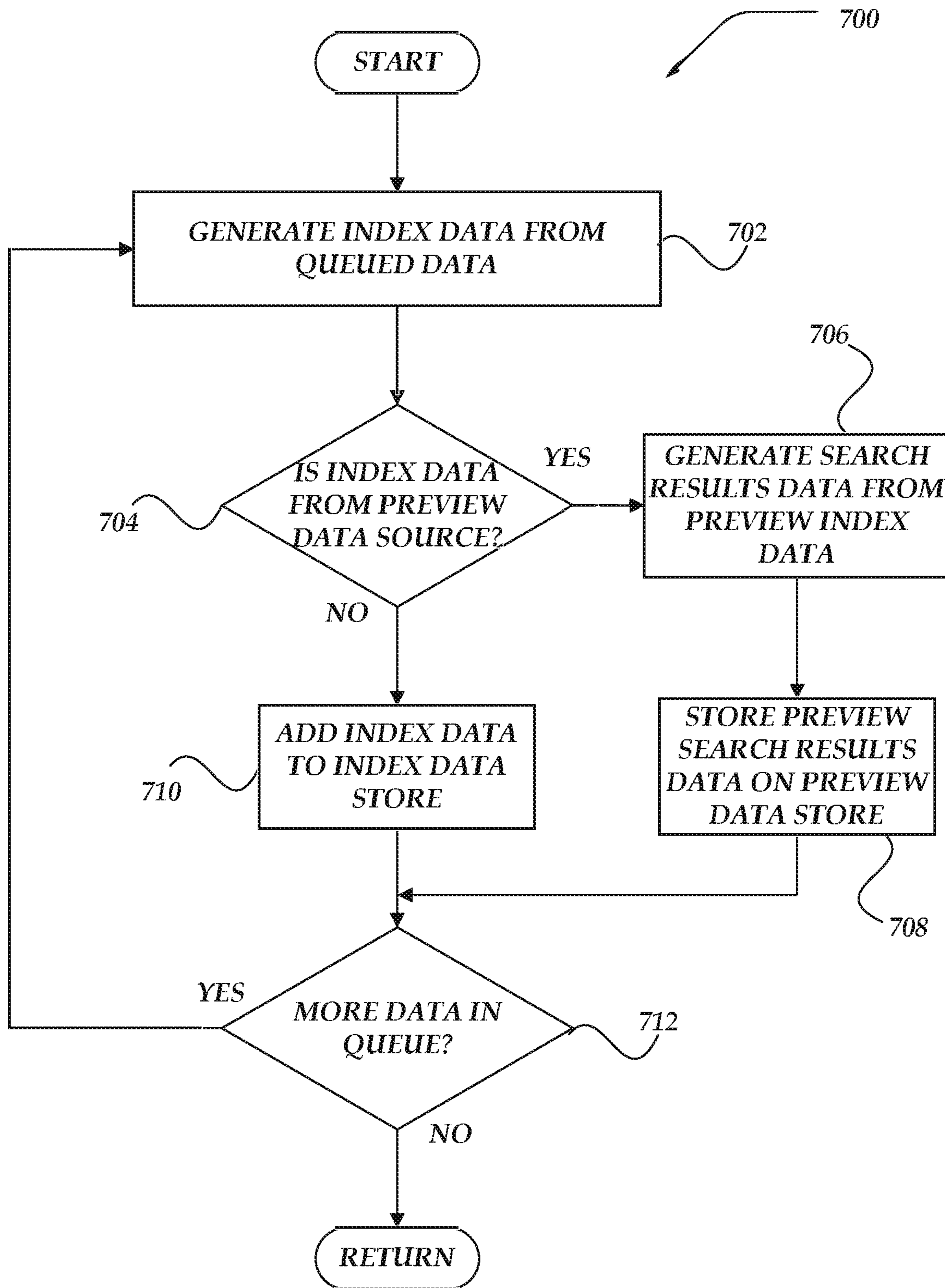

Fig. 7

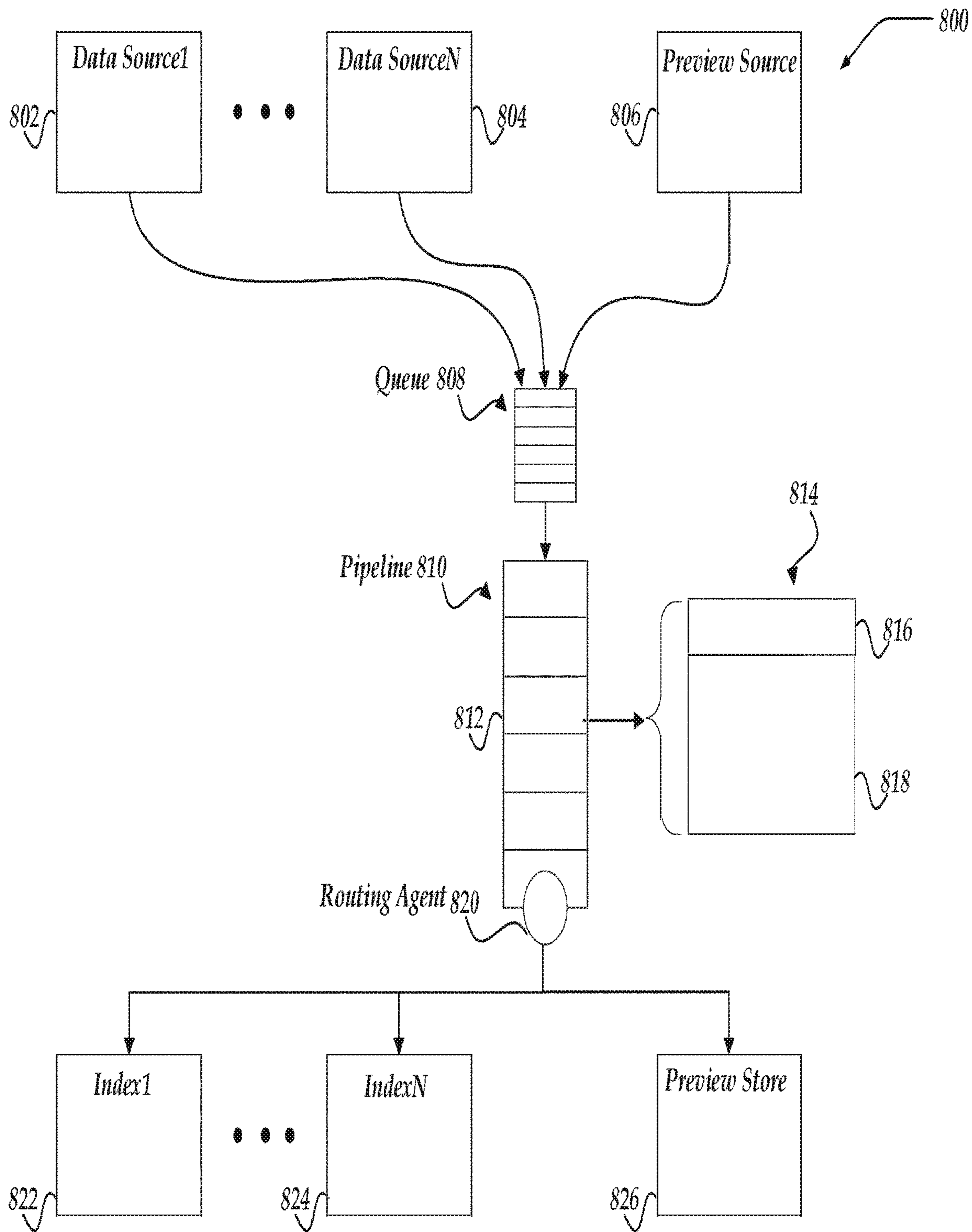

Fig. 8

PREVIEWING RAW DATA PARSING**CROSS-REFERENCE TO RELATED APPLICATIONS**

This application is a continuation of U.S. application Ser. No. 15/224,655, filed Jul. 31, 2016, now U.S. Pat. No. 9,740,788, entitled "Interactive Selection and Display of A Raw Data Parsing," which is a continuation of U.S. application Ser. No. 14/929,332, filed Oct. 31, 2015, now U.S. Pat. No. 9,442,981, which is a continuation of U.S. application Ser. No. 14/445,001, filed Jul. 28, 2014, now U.S. Pat. No. 9,208,206, which is a continuation of U.S. application Ser. No. 13/588,939, filed Aug. 17, 2012, now U.S. Pat. No. 8,825,664, each of which is incorporated in its entirety by reference herein.

BACKGROUND

The rapid increase in the production and collection of machine-generated data has created large data sets that are difficult to search. The machine data can include sequences of time stamped records that may occur in one or more usually continuous streams. Further, machine data often represents activity made up of discrete events.

Often, search engines may receive raw data from various data sources, including machine data. In some cases, search engines may be configured to transform raw data in various ways prior to storing it as indexed data. Sometimes the search engine configuration information used to process the received raw data may include improper and/or ineffective rules that may generate ineffective index data. If such improper index data may be added to an index store it may pollute the index reducing the quality of search results that may be produced.

BRIEF SUMMARY

This invention relates generally to information organization, search, and retrieval and more particularly, previewing search results before received search engine data is indexed.

BRIEF DESCRIPTION OF THE SEVERAL VIEWS OF THE DRAWING

Non-limiting and non-exhaustive embodiments are described with reference to the following drawings. In the drawings, like reference numerals refer to like parts throughout the various figures unless otherwise specified.

For a better understanding, reference will be made to the following Description Of The Various Embodiments, which is to be read in association with the accompanying drawings, wherein:

FIG. 1. Illustrates a system environment in which various embodiments may be implemented;

FIG. 2A. Shows a schematic drawing of a rack of blade servers;

FIG. 2B. Illustrates a schematic embodiment of a blade server that may be included in a rack of blade servers such as that shown in FIG. 2A;

FIG. 3. Shows a schematic embodiment of a mobile device;

FIG. 4. Illustrates a schematic embodiment of a network device;

FIG. 5. Shows an overview flowchart for an index previewing process in accordance with at least one of the various embodiments;

FIG. 6. Shows a flowchart for a process to send preview data to a queue in accordance with at least one of the various embodiments;

FIG. 7. Shows a flowchart for a process for processing data chunks in a pipeline in accordance with at least one of the various embodiments; and

FIG. 8. Illustrates a logical architecture of a system for indexing previewing in accordance with at least one of the various embodiments.

DETAILED DESCRIPTION OF THE INVENTION

Various embodiments now will be described more fully hereinafter with reference to the accompanying drawings, which form a part hereof, and which show, by way of illustration, specific exemplary embodiments by which the invention may be practiced. The embodiments may, however, be embodied in many different forms and should not be construed as limited to the embodiments set forth herein; rather, these embodiments are provided so that this disclosure will be thorough and complete, and will fully convey the scope of the embodiments to those skilled in the art. Among other things, the various embodiments may be methods, systems, media or devices. Accordingly, the various embodiments may take the form of an entirely hardware embodiment, an entirely software embodiment or an embodiment combining software and hardware aspects. The following detailed description is, therefore, not to be taken in a limiting sense.

Throughout the specification and claims, the following terms take the meanings explicitly associated herein, unless the context clearly dictates otherwise. The phrase "in one embodiment" as used herein does not necessarily refer to the same embodiment, though it may. Furthermore, the phrase "in another embodiment" as used herein does not necessarily refer to a different embodiment, although it may. Thus, as described below, various embodiments may be readily combined, without departing from the scope or spirit of the invention.

In addition, as used herein, the term "or" is an inclusive "or" operator, and is equivalent to the term "and/or," unless the context clearly dictates otherwise. The term "based on" is not exclusive and allows for being based on additional factors not described, unless the context clearly dictates otherwise. In addition, throughout the specification, the meaning of "a," "an," and "the" include plural references. The meaning of "in" includes "in" and "on."

For example embodiments, the following terms are also used herein according to the corresponding meaning, unless the context clearly dictates otherwise.

The term "machine data" as used herein may include server logs and other types of machine data (i.e., data generated by machines). In at least one of the various embodiments, machine data streams may be time stamped to create time stamped events. For example, information processing environments, such as, firewalls, routers, web servers, application servers and databases may generate streams of time series data in the form of events. In some cases, events may be generated hundreds or thousands of times per second.

The term "time series data" as used herein is data where each data record has a timestamp associated with it. A "Time Series Search Engine" is a search engine which, in at least one of the various embodiments, can perform queries limited by a time range (such as between one time and another, or data earlier than a given time, or the like) on the stored

data and/or generate results ordered by time and/or time-stamps (such as from earliest-to-latest or vice versa).

The term “data repository” as used herein refers to data sources that may contain unstructured or structured data, such as databases, file systems, search engine indexes, or the like. In at least one of the various embodiments, a data repository may be a live stream of data. In other cases, a data repository may be static data, or a combination of live data or static data. In at least one of the various embodiments, data repositories may provide interfaces such as, application programming interfaces (API) for receiving requests, queries regarding the data stored in the data repository.

The term “configuration information” as used herein refers to data and/or directives that may be employed by an indexer application or a previewing application for processing, such as indexing, transforming, and/or interpreting raw data received from data sources. The configuration information may be saved using various storage mechanisms, such as, file systems, databases, computer memory, or the like.

Configuration information may include rules that may be comprised of filters, matching functions, rules for determining “event boundaries” within raw data and/or preview data (e.g., rules for dividing an event stream into individual lines, rules for merging lines into multi-line events, or the like), rules for locating and parsing timestamps in raw data and/or preview data, or the like. The configuration information may be employed by the indexer application to identify events of interest that may be included in machine-generated data, identify and extract fields within events, or the like.

The term “raw data” as used herein refers to non-indexed data before it is processed by an indexer application or a previewing application. In at least one of the various embodiments, the raw data may be machine-generated data. Indexer applications and previewing applications may use the configuration information to determine how to interpret the raw data.

The term “preview data” as used herein refers to a portion of the raw data that is received from a preview data source and designated for additional processing. After the preview data is indexed by the indexer application, the preview index data is stored in a separate preview store rather than being automatically stored in an index store. Once the configuration information for the preview index data is approved, subsequent raw data received from the preview data source is automatically indexed and stored in the index store.

The term “index data” as used herein refers to raw data and/or preview data that has been indexed and processed into a format suitable for adding to an index store by an indexer application. Indexer applications may generate index data from raw data received from data sources and/or preview data sources.

The term “worker agent” as used herein refers to processes that perform actions on the raw data and/or preview data to transform it into index data and/or preview index data. Worker agents may employ configuration information to determine how to process the raw data and/or preview data.

The term “queue” as used herein refers to system components that receive chunks of raw data and/or preview data from various data sources and/or preview data sources. Queues may act as staging areas before the raw data and/or preview data are further processed. Raw data and/or preview data may be removed from a queue and transferred to one or more pipelines for further processing.

The term “pipeline” as used herein refers to system components that may be associated with one or more processors, such as, worker agents. In some embodiments,

the first processor in a pipeline may be responsible for retrieving raw data chunks and/or preview data chunks from a queue and sending them to other processors. Other processors may perform operations on the raw data chunks and/or preview data chunks, such as, breaking the data into lines or extracting fields based on configuration information. In at least one of the various embodiments, the last processor for a pipeline may transfer data chunks to another queue for consumption by a different pipeline for additional processing. As data chunks advance through the pipeline, processors (e.g., worker agents) may process the raw data chunks and/or preview data chunks into index data and/or preview index data.

The term “query string” as used herein refers to commands and/or sequences of commands that are used for querying, searching and/or retrieving data from a data repository. Queries generally produce a result or results based on the form and structure of the particular query string. Query results may be sorted and grouped based on the structure and form of the query string. In at least one of the various embodiments, query strings may include commands, operators, functions, or the like for calculating values based on the stored records, including functions that produce result sets that may include statistics and metrics about the data stored in data repository. Structured Query Language (SQL) is a well-known query language often used to form queries for relational databases. However, the various embodiments are not limited to using SQL-like formatting for query strings. Accordingly, other well known query languages and/or custom query languages may be employed consistent with what is claimed herein.

The following briefly describes the embodiments of the invention in order to provide a basic understanding of some aspects of the invention. This brief description is not intended as an extensive overview. It is not intended to identify key or critical elements, or to delineate or otherwise narrow the scope. Its purpose is merely to present some concepts in a simplified form as a prelude to the more detailed description that is presented later.

Briefly stated, various embodiments are directed towards previewing the results generated from indexing raw data from selected preview data sources before the corresponding index data is added to an index store. In at least one of the various embodiments, raw data may be received from a preview data source, and/or data source. In at least one of the various embodiments, after an initial set of configuration information is established, the preview data may be submitted to a pipeline that may perform index processing on the preview data and other raw data. The preview index data is stored in a preview data store that is separate from the index data store that stores the indexed data.

In at least one of the various embodiments, a previewing application may generate preview results based on the preview index data and the configuration information. In at least one of the various embodiments, the preview results enable a user to view how the preview data is being processed by the indexing application. In at least one of the various embodiments, if the preview results may not be acceptable, the configuration information employed to generate the preview index data may be modified.

In at least one of the various embodiments, the preview application may enable iterative modification of the configuration information used for processing the preview data until the generated preview results may be acceptable. In at least one of the various embodiments, once the configuration information for the preview index data is approved, subse-

quent raw data received from the preview data source is automatically indexed and stored in the index store.

Illustrative Operating Environment FIG. 1 shows components of an environment in which various embodiments may be practiced. Not all of the components may be required to practice the various embodiments, and variations in the arrangement and type of the components may be made without departing from the spirit or scope of the various embodiments.

In at least one embodiment, cloud network 102 enables one or more network services for a user based on the operation of corresponding arrangements 104 and 106 of virtually any type of networked computing device. As shown, the networked computing devices may include previewing server device 112, indexing server device 114, enclosure of blade servers 110, enclosure of server computers 116, super computer network device 118, and the like. Although not shown, one or more mobile devices may be included in cloud network 102 in one or more arrangements to provide one or more network services to a user. Also, these arrangements of networked computing devices may or may not be mutually exclusive of each other.

Additionally, the user may employ a plurality of virtually any type of wired or wireless networked computing devices to communicate with cloud network 102 and access at least one of the network services enabled by one or more of arrangements 104 and 106. These networked computing devices may include tablet mobile device 122, handheld mobile device 124, wearable mobile device 126, desktop network device 120, and the like. Although not shown, in various embodiments, the user may also employ notebook computers, desktop computers, microprocessor-based or programmable consumer electronics, network appliances, mobile telephones, smart telephones, pagers, radio frequency (RF) devices, infrared (IR) devices, Personal Digital Assistants (PDAs), televisions, integrated devices combining at least one of the preceding devices, and the like.

One embodiment of a mobile device is described in more detail below in conjunction with FIG. 3. Generally, mobile devices may include virtually any substantially portable networked computing device capable of communicating over a wired, wireless, or some combination of wired and wireless network.

In various embodiments, network 102 may employ virtually any form of communication technology and topology. For example, network 102 can include local area networks Personal Area Networks (PANs), (LANs), Campus Area Networks (CANs), Metropolitan Area Networks (MANs) Wide Area Networks (WANs), direct communication connections, and the like, or any combination thereof. On an interconnected set of LANs, including those based on differing architectures and protocols, a router acts as a link between LANs, enabling messages to be sent from one to another. In addition, communication links within networks may include virtually any type of link, e.g., twisted wire pair lines, optical fibers, open air lasers or coaxial cable, plain old telephone service (POTS), wave guides, acoustic, full or fractional dedicated digital communication lines including T1, T2, T3, and T4, and/or other carrier and other wired media and wireless media. These carrier mechanisms may include E-carriers, Integrated Services Digital Networks (ISDNs), universal serial bus (USB) ports, Firewire ports, Thunderbolt ports, Digital Subscriber Lines (DSLs), wireless links including satellite links, or other communications links known to those skilled in the art. Moreover, these communication links may further employ any of a variety of digital signaling technologies, including without limit, for

example, DS-0, DS-1, DS-2, DS-3, DS-4, OC-3, OC-12, OC-48, or the like. Furthermore, remotely located computing devices could be remotely connected to networks via a modem and a temporary communication link. In essence, network 102 may include virtually any communication technology by which information may travel between computing devices. Additionally, in the various embodiments, the communicated information may include virtually any kind of information including, but not limited to processor-readable instructions, data structures, program modules, applications, raw data, control data, archived data, video data, voice data, image data, text data, and the like.

Network 102 may be partially or entirely embodied by one or more wireless networks. A wireless network may include any of a variety of wireless sub-networks that may further overlay stand-alone ad-hoc networks, and the like. Such sub-networks may include mesh networks, Wireless LAN (WLAN) networks, Wireless Router (WR) mesh, cellular networks, pico networks, PANs, Open Air Laser networks, Microwave networks, and the like. Network 102 may further include an autonomous system of intermediate network devices such as terminals, gateways, routers, switches, firewalls, load balancers, and the like, which are coupled to wired and/or wireless communication links. These autonomous devices may be operable to move freely and randomly and organize themselves arbitrarily, such that the topology of network 102 may change rapidly.

Network 102 may further employ a plurality of wired and wireless access technologies, e.g., 2nd (2G), 3rd (3G), 4th (4G), 5th (5G) generation wireless access technologies, and the like, for mobile devices. These wired and wireless access technologies may also include Global System for Mobile communication (GSM), General Packet Radio Services (GPRS), Enhanced Data GSM Environment (EDGE), Code Division Multiple Access (CDMA), Wideband Code Division Multiple Access (WCDMA), Long Term Evolution Advanced (LTE), Universal Mobile Telecommunications System (UMTS), Orthogonal frequency-division multiplexing (OFDM), Wideband Code Division Multiple Access (W-CDMA), Code Division Multiple Access 2000 (CDMA2000), Evolution-Data Optimized (EV-DO), High-Speed Downlink Packet Access (HSDPA), IEEE 802.16 Worldwide Interoperability for Microwave Access (WiMax), ultra wide band (UWB), user datagram protocol (UDP), transmission control protocol/Internet protocol (TCP/IP), any portion of the Open Systems Interconnection (OSI) model protocols, Short Message Service (SMS), Multimedia Messaging Service (MMS), Web Access Protocol (WAP), Session Initiation Protocol/Real-time Transport Protocol (SIP/RTP), or any of a variety of other wireless or wired communication protocols. In one non-limiting example, network 102 may enable a mobile device to wirelessly access a network service through a combination of several radio network access technologies such as GSM, EDGE, SMS, HSDPA, LTE and the like.

Enclosure of Blade Servers

FIG. 2A shows one embodiment of an enclosure of blade servers 200, which are also illustrated in FIG. 1. Enclosure of blade servers 200 may include many more or fewer components than those shown in FIG. 2A. However, the components shown are sufficient to disclose an illustrative embodiment. Generally, a blade server is a stripped down server computing device with a modular design optimized to minimize the use of physical space and energy. A blade enclosure can include several blade servers and provide each with power, cooling, network interfaces, input/output interfaces, and resource management. Although not shown, an

enclosure of server computers typically includes several computers that merely require a network connection and a power cord connection to operate. Each server computer often includes redundant components for power and interfaces.

As shown in the figure, enclosure **200** contains power supply **204**, and input/output interface **206**, rack logic **208**, several blade servers **210**, **212**, **214**, and **216**, and backplane **202**. Power supply **204** provides power to each component and blade server within the enclosure. The input/output interface **206** provides internal and external communication for components and blade servers within the enclosure. Backplane **208** can enable passive and active communication of power, logic, input signals, and output signals for each blade server.

Illustrative Blade Server

FIG. 2B illustrates an illustrative embodiment of blade server **250**, which may include many more or fewer components than those shown. As shown in FIG. 2A, a plurality of blade servers may be included in one enclosure that shares resources provided by the enclosure to reduce size, power, and cost.

Blade server **250** includes processor **252** which communicates with memory **256** via bus **254**. Blade server **250** also includes input/output interface **290**, processor-readable stationary storage device **292**, and processor-readable removable storage device **294**. Input/output interface **290** can enable blade server **250** to communicate with other blade servers, mobile devices, network devices, and the like. Interface **290** may provide wireless and/or wired communication links for blade server. Processor-readable stationary storage device **292** may include one or more devices such as an electromagnetic storage device (hard disk), solid state hard disk (SSD), hybrid of both an SSD and a hard disk, and the like. In some configurations, a blade server may include multiple storage devices. Also, processor-readable removable storage device **294** enables processor **252** to read non-transitive storage media for storing and accessing processor-readable instructions, modules, data structures, and other forms of data. The non-transitive storage media may include Flash drives, tape media, floppy media, and the like.

Memory **256** may include Random Access Memory (RAM), Read-Only Memory (ROM), hybrid of RAM and ROM, and the like. As shown, memory **256** includes operating system **258** and basic input/output system (BIOS) **260** for enabling the operation of blade server **250**. In various embodiments, a general-purpose operating system may be employed such as a version of UNIX, LINUX™, a specialized server operating system such as Microsoft's Windows Server™ and Apple Computer's IoS Server™, or the like.

Memory **256** further includes one or more data storage **270**, which can be utilized by blade server **250** to store, among other things, applications **280** and/or other data. Data stores **270** may include program code, data, algorithms, and the like, for use by processor **252** to execute and perform actions. In one embodiment, at least some of data store **270** might also be stored on another component of blade server **250**, including, but not limited to, processor readable removable storage device **294**, processor-readable stationary storage device **292**, or any other processor-readable storage device (not shown). Data storage **270** may include, for example, preview data **274**, indexes **276**, or configurations **278**.

Applications **280** may include processor executable instructions which, when executed by blade server **250**, transmit, receive, and/or otherwise process messages, audio, video, and enable communication with other networked

computing devices. Examples of application programs include database servers, file servers, calendars, transcoders, and so forth. Applications **280** may include, for example, indexer application **282**, and previewing application **284**.

Human interface components (not pictured), may be remotely associated with blade server **250**, which can enable remote input to and/or output from blade server **250**. For example, information to a display or from a keyboard can be routed through the input/output interface **290** to appropriate peripheral human interface components that are remotely located. Examples of peripheral human interface components include, but are not limited to, an audio interface, a display, keypad, pointing device, touch interface, and the like.

Illustrative Mobile Device

FIG. 3 shows one embodiment of mobile device **300** that may include many more or less components than those shown. Mobile device **300** may represent, for example, at least one embodiment of mobile devices shown in FIG. 1.

Mobile device **300** includes processor **302** in communication with memory **304** via bus **328**. Mobile device **300** also includes power supply **330**, network interface **332**, audio interface **356**, display **350**, keypad **352**, illuminator **354**, video interface **342**, input/output interface **338**, haptic interface **364**, global positioning systems (GPS) receiver **358**, Open air gesture interface **360**, temperature interface **362**, camera(s) **340**, projector **346**, pointing device interface **366**, processor-readable stationary storage device **334**, and processor-readable removable storage device **336**. Power supply **330** provides power to mobile device **300**. A rechargeable or nonrechargeable battery may be used to provide power. The power may also be provided by an external power source, such as an AC adapter or a powered docking cradle that supplements and/or recharges the battery. And in one embodiment, although not shown, a gyroscope may be employed within mobile device **300** to measuring and/or maintaining an orientation of mobile device **300**.

Mobile device **300** may optionally communicate with a base station (not shown), or directly with another computing device. Network interface **332** includes circuitry for coupling mobile device **300** to one or more networks, and is constructed for use with one or more communication protocols and technologies including, but not limited to, protocols and technologies that implement any portion of the Open Systems Interconnection (OSI) model for mobile communication (GSM), code division multiple access (CDMA), time division multiple access (TDMA), user datagram protocol (UDP), transmission control protocol/Internet protocol (TCP/IP), Short Message Service (SMS), Multimedia Messaging Service (MMS), general packet radio service (GPRS), Web Access Protocol (WAP), ultra wide band (UWB), IEEE 802.16 Worldwide Interoperability for Microwave Access (WiMax), Session Initiation Protocol/Realtime Transport Protocol (SIP/RTP), General Packet Radio Services (GPRS), Enhanced Data GSM Environment (EDGE), Wideband Code Division Multiple Access (WCDMA), Long Term Evolution Advanced (LTE), Universal Mobile Telecommunications System (UMTS), Orthogonal frequency-division multiplexing (OFDM), Code Division Multiple Access 2000 (CDMA2000), Evolution-Data Optimized (EV-DO), High-Speed Downlink Packet Access (HSDPA), or any of a variety of other wireless communication protocols. Network interface **332** is sometimes known as a transceiver, transceiving device, or network interface card (NIC).

Audio interface **356** is arranged to produce and receive audio signals such as the sound of a human voice. For example, audio interface **356** may be coupled to a speaker and microphone (not shown) to enable telecommunication with others and/or generate an audio acknowledgement for some action. A microphone in audio interface **356** can also be used for input to or control of mobile device **300**, e.g., using voice recognition, detecting touch based on sound, and the like.

Display **350** may be a liquid crystal display (LCD), gas plasma, electronic ink, light emitting diode (LED), Organic LED (OLED) or any other type of light reflective or light transmissive display that can be used with a computing device. Display **350** may also include a touch interface **344** arranged to receive input from an object such as a stylus or a digit from a human hand, and may use resistive, capacitive, surface acoustic wave (SAW), infrared, radar, or other technologies to sense touch and/or gestures. Projector **346** may be a remote handheld projector or an integrated projector that is capable of projecting an image on a remote wall or any other reflective object such as a remote screen.

Video interface **342** may be arranged to capture video images, such as a still photo, a video segment, an infrared video, or the like. For example, video interface **342** may be coupled to a digital video camera, a web-camera, or the like. Video interface **342** may comprise a lens, an image sensor, and other electronics. Image sensors may include a complementary metaloxide-semiconductor (CMOS) integrated circuit, charge-coupled device (CCD), or any other integrated circuit for sensing light.

Keypad **352** may comprise any input device arranged to receive input from a user. For example, keypad **352** may include a push button numeric dial, or a keyboard. Keypad **352** may also include command buttons that are associated with selecting and sending images. Illuminator **354** may provide a status indication and/or provide light. Illuminator **354** may remain active for specific periods of time or in response to events. For example, when illuminator **354** is active, it may backlight the buttons on keypad **352** and stay on while the mobile device is powered. Also, illuminator **354** may backlight these buttons in various patterns when particular actions are performed, such as dialing another mobile device. Illuminator **354** may also cause light sources positioned within a transparent or translucent case of the mobile device to illuminate in response to actions.

Mobile device **300** also comprises input/output interface **338** for communicating with external peripheral devices or other computing devices such as other mobile devices and network devices. The peripheral devices may include an audio headset, display screen glasses, remote speaker system, remote speaker and microphone system, and the like. Input/output interface **338** can utilize one or more technologies, such as Universal Serial Bus (USB), Infrared, WiFi, WiMax, Bluetooth™, and the like. Haptic interface **364** is arranged to provide tactile feedback to a user of the mobile device. For example, the haptic interface **364** may be employed to vibrate mobile device **300** in a particular way when another user of a computing device is calling. Temperature interface **362** may be used to provide a temperature measurement input and/or a temperature changing output to a user of mobile device **300**. Open air gesture interface **360** may sense physical gestures of a user of mobile device **300**, for example, by using single or stereo video cameras, radar, a gyroscopic sensor inside a device held or worn by the user, or the like. Camera **340** may be used to track physical eye movements of a user of mobile device **300**.

GPS transceiver **358** can determine the physical coordinates of mobile device **300** on the surface of the Earth, which typically outputs a location as latitude and longitude values. GPS transceiver **358** can also employ other geo-positioning mechanisms, including, but not limited to, triangulation, assisted GPS (AGPS), Enhanced Observed Time Difference (E-OTD), Cell Identifier (CI), Service Area Identifier (SAi), Enhanced Timing Advance (ETA), Base Station Subsystem (BSS), or the like, to further determine the physical location of mobile device **300** on the surface of the Earth. It is understood that under different conditions, GPS transceiver **358** can determine a physical location for mobile device **300**. In at least one embodiment, however, mobile device **300** may, through other components, provide other information that may be employed to determine a physical location of the device, including for example, a Media Access Control (MAC) address, IP address, and the like.

Human interface components can be peripheral devices that are physically separate from mobile device **300**, allowing for remote input and/or output to mobile device **300**. For example, information routed as described here through human interface components such as display **350** or keyboard **352** can instead be routed through network interface **332** to appropriate human interface components located remotely. Examples of human interface peripheral components that may be remote include, but are not limited to, audio devices, pointing devices, keypads, displays, cameras, projectors, and the like. These peripheral components may communicate over a Pico Network such as Bluetooth™, Zigbee™ and the like. One non-limiting example of a mobile device with such peripheral human interface components is a wearable computing device, which might include a remote pico projector along with one or more cameras that remotely communicate with a separately located mobile device to sense a user's gestures toward portions of an image projected by the pico projector onto a reflected surface such as a wall or the user's hand.

A mobile device may include a browser application that is configured to receive and to send web pages, web-based messages, graphics, text, multimedia, and the like. The mobile device's browser application may employ virtually any programming language, including a wireless application protocol messages (WAP), and the like. In at least one embodiment, the browser application is enabled to employ Handheld Device Markup Language (HDML), Wireless Markup Language (WML), WMLScript, JavaScript, Standard Generalized Markup Language (SGML), HyperText Markup Language (HTML), eXtensible Markup Language (XML), HTML5, and the like.

Memory **304** may include Random Access Memory (RAM), Read-Only Memory (ROM), and/or other types of memory. Memory **304** illustrates an example of computer-readable storage media (devices) for storage of information such as computer-readable instructions, data structures, program modules or other data. Memory **304** stores a basic input/output system (BIOS) **308** for controlling low-level operation of mobile device **300**. The memory also stores an operating system **306** for controlling the operation of mobile device **300**. It will be appreciated that this component may include a general-purpose operating system such as a version of UNIX, or LINUX™, or a specialized mobile computer communication operating system such as Windows Mobile™, or the Symbian® operating system. The operating system may include, or interface with a Java virtual machine module that enables control of hardware components and/or operating system operations via Java application programs.

Memory 304 further includes one or more data storage 310, which can be utilized by mobile device 300 to store, among other things, applications 320 and/or other data. For example, data storage 310 may also be employed to store information that describes various capabilities of mobile device 300. The information may then be provided to another device based on any of a variety of events, including being sent as part of a header during a communication, sent upon request, or the like. Data storage 310 may also be employed to store social networking information including address books, buddy lists, aliases, user profile information, or the like. Data storage 310 may further include program code, data, algorithms, and the like, for use by a processor, such as processor 302 to execute and perform actions. In one embodiment, at least some of data storage 310 might also be stored on another component of mobile device 300, including, but not limited to, non-transitory processor-readable removable storage device 336, processor-readable stationary storage device 334, or even external to the mobile device. Data storage 310 may include, for example, preview data 314.

Applications 320 may include computer executable instructions which, when executed by mobile device 300, transmit, receive, and/or otherwise process instructions and data. Applications 320 may include, for example, previewing application 322. Other examples of application programs include calendars, search programs, email client applications, IM applications, SMS applications, Voice Over Internet Protocol (VOiP) applications, contact managers, task managers, transcoders, database programs, word processing programs, security applications, spreadsheet programs, games, search programs, and so forth.

Illustrative Network Device

FIG. 4 shows one embodiment of network device 400 that may be included in a system implementing the invention. Network device 400 may include many more or less components than those shown in FIG. 4. However, the components shown are sufficient to disclose an illustrative embodiment for practicing the present invention. Network device 400 may represent, for example, one embodiment of at least one of previewing server device 112, indexing server device 114, or 120 of FIG. 1.

As shown in the figure, network device 400 includes a processor 402 in communication with a memory 404 via a bus 428. Network device 400 also includes a power supply 430, network interface 432, audio interface 456, display 450, keyboard 452, input/output interface 438, processor-readable stationary storage device 434, and processor-readable removable storage device 436. Power supply 430 provides power to network device 400.

Network interface 432 includes circuitry for coupling network device 400 to one or more networks, and is constructed for use with one or more communication protocols and technologies including, but not limited to, protocols and technologies that implement any portion of the Open Systems Interconnection model (OSI model), global system for mobile communication (GSM), code division multiple access (CDMA), time division multiple access (TDMA), user datagram protocol (UDP), transmission control protocol/Internet protocol (TCP/IP), Short Message Service (SMS), Multimedia Messaging Service (MMS), general packet radio service (GPRS), WAP, ultra wide band (UWB), IEEE 802.16 Worldwide Interoperability for Microwave Access (WiMax), Session Initiation Protocol/Real-time Transport Protocol (SIP/RTP), or any of a variety of other wired and wireless communication protocols. Network interface 432 is sometimes known as a transceiver, trans-

ceiving device, or network interface card (NIC). Network device 400 may optionally communicate with a base station (not shown), or directly with another computing device.

Audio interface 456 is arranged to produce and receive audio signals such as the sound of a human voice. For example, audio interface 456 may be coupled to a speaker and microphone (not shown) to enable telecommunication with others and/or generate an audio acknowledgement for some action. A microphone in audio interface 456 can also be used for input to or control of network device 400, for example, using voice recognition.

Display 450 may be a liquid crystal display (LCD), gas plasma, electronic ink, light emitting diode (LED), Organic LED (OLED) or any other type of light reflective or light transmissive display that can be used with a computing device. Display 450 may be a handheld projector or pico projector capable of projecting an image on a wall or other object.

Network device 400 also may also comprise input/output interface 438 for communicating with external devices not shown in FIG. 4. Input/output interface 438 can utilize one or more wired or wireless communication technologies, such as USB™, Firewire™ WiFi, WiMax, Thunderbolt™, Infrared, Bluetooth™, Zigbee™, serial port, parallel port, and the like.

Human interface components can be physically separate from network device 400, allowing for remote input and/or output to network device 400. For example, information routed as described here through human interface components such as display 450 or keyboard 452 can instead be routed through the network interface 432 to appropriate human interface components located elsewhere on the network. Human interface components include any component that allows the computer to take input from, or send output to, a human user of a computer.

Memory 404 may include Random Access Memory (RAM), Read-Only Memory (ROM), and/or other types of memory. Memory 404 illustrates an example of computer-readable storage media (devices) for storage of information such as computer-readable instructions, data structures, program modules or other data. Memory 404 stores a basic input/output system (BIOS) 408 for controlling low-level operation of network device 400. The memory also stores an operating system 406 for controlling the operation of network device 400. It will be appreciated that this component may include a general-purpose operating system such as a version of UNIX, or LINUX™, or a specialized operating system such as Microsoft Corporation's Windows® operating system, or the Apple Corporation's IOs® operating system. The operating system may include, or interface with a Java virtual machine module that enables control of hardware components and/or operating system operations via Java application programs.

Memory 404 further includes one or more data storage 410, which can be utilized by network device 400 to store, among other things, applications 420 and/or other data. For example, data storage 410 may also be employed to store information that describes various capabilities of network device 400. The information may then be provided to another device based on any of a variety of events, including being sent as part of a header during a communication, sent upon request, or the like. Data storage 410 may also be employed to store social networking information including address books, buddy lists, aliases, user profile information, or the like. Data stores 410 may further include program code, data, algorithms, and the like, for use by a processor, such as processor 402 to execute and perform actions. In one

embodiment, at least some of data store **410** might also be stored on another component of network device **400**, including, but not limited to, non-transitory media inside processor-readable removable storage device **436**, processor-readable stationary storage device **434**, or any other computer-readable storage device within network device **400**, or even external to network device **400**. Data storage **410** may include, for example, indexes **412**, preview data **414**, and configurations **416**.

Applications **420** may include computer executable instructions which, when executed by network device **400**, transmit, receive, and/or otherwise process messages (e.g., SMS, Multimedia Messaging Service (MMS), Instant Message (IM), email, and/or other messages), audio, video, and enable telecommunication with another user of another mobile device. Other examples of application programs include calendars, search programs, email client applications, IM applications, SMS applications, Voice Over Internet Protocol (VOiP) applications, contact managers, task managers, transcoders, database programs, word processing programs, security applications, spreadsheet programs, games, search programs, and so forth. Applications **420** may include, for example, indexer application **422**, and previewing application **424**.

Generalized Operation

FIGS. **5-7** represent the generalized operation of indexing preview in accordance with at least one of the various embodiments.

FIG. **5** shows an overview flowchart for index previewing process **500** in accordance with at least one of the various embodiments. After at start block, at block **502**, in at least one of the various embodiments, determine one or more preview data sources and receive a portion of raw data from the determined preview data source. In at least one of the various embodiments, determining a preview data source may be based on type of index and/or search engine that may use the collected data.

In at least one of the various embodiments, preview data sources may be selected by browsing with a user-interface. Also, in at least one of the various embodiments, preview data sources may be selected based on one or more system configuration values and/or default values.

In at least one of the various embodiments, raw data may include unstructured data (e.g., machine data and/or log files) and/or structured data (e.g., database result sets, XML files, or the like). In at least one of the various embodiments, raw data may be received and/or processed in chunks, packets, streams, or the like.

In at least one of the various embodiments, if the preview data source includes a large data set, the previewing application may retrieve a portion of the data set sufficient to generate acceptable preview results. In at least one of the various embodiments, the amount of data collected may be determined on a default and/or pre-set maximum value (e.g., 2 mb). Also, in at least one of the various embodiments, the previewing application may scan the preview data as it is received and determine based on patterns in the data that enough data has been received to generate a preview. In at least one of the various embodiments, if additional data is required, the portion size may be increased based on user feedback. Further, in at least one of the various embodiments, the previewing application may determine that more data from the preview data source may be required based on a failure to produce sufficient preview results.

At block **504**, in at least one of the various embodiments, determine the initial configuration information that may be employed to process the preview data. In at least one of the

various embodiments, initial configuration information may be determined based on in part default values for the system, default values for a user, values set by a user before receiving the data, or the like. Also, in at least one of the various embodiments, a previewing application may detect patterns in the initial data portions that may be employed to determine a set of initial configuration information. For example, in at least one of the various embodiments, the previewing application may scan the data received from the preview data source and determine that it includes data patterns that may be similar to those expected for web server access logs. In this case, in at least one of the various embodiments, the previewing application may determine that the initial configuration information may include previously defined rules for processing web server access logs.

At block **506**, in at least one of the various embodiments, further determine the candidate configuration information that may be employed to process the data received from the preview data source. In at least one of the various embodiments, the user and/or the system may modify the candidate configuration information. In at least one of the various embodiments, changes to the candidate configuration information may be based on the type of data being received as well as the purpose and/or type of report the system may be expected to produce.

In at least one of the various embodiments, a user may modify the candidate configuration information by adding sets of rules that may be selected from among one or more proposed rules presented in a user-interface. In at least one of the various embodiments, proposed rules may be comprised of filters, matching functions, or the like that may be arranged to respond to characteristics of the raw data. For example, in at least one of the various embodiments, an indexing application may provide one or more rules for matching web page uniform resource locators (URLs) that may be included in access log files for a web server. In at least one of the various embodiments, such rules may include one or more well-known regular expressions that may be employed to match string patterns that match the pattern of a web URL (e.g., url=htt*). In other cases, a user may modify the configuration information to prevent unwanted URLs from appearing in the indexed data by adding rules that may exclude the unwanted URLs.

At block **508**, in at least one of the various embodiments, the raw data may be processed based on configuration information that may be associated with the raw data and the results may be provided to the user.

In at least one of the various embodiments, if the preview results may not be available, progress metrics related to the previewing process may be shown to a user. Also, if a portion of the preview results may be available, the portion of the results may be provided along with the previewing progress metrics.

At decision block **510**, in at least one of the various embodiments, if the results generated based on the preview data processing are satisfactory, control may move to block **510**. Otherwise, in at least one of the various embodiments, control may loop back to block **504** for to receive further modification to the configuration information.

In at least one of the various embodiments, preview results may be used to determine if the correct timestamp is being associated with the events included in the raw data. Also, in at least one of the various embodiments, by examining the preview results a user may determine if the delineation between events included in the raw data is correct.

At block **512**, in at least one of the various embodiments, the candidate configuration information may be approved and committed to stable storage. In at least one of the various embodiments, committed configuration information may be associated with one or more data sources and employed by an indexer application to process raw data into index data that may be stored in production index stores and made available for responding to search requests.

In at least one of the various embodiments, configuration information may be stored in a file system and/or a database and made available to other users that may be processing data similar to the data that is in the preview data store. Next, in at least one of the various embodiments, control may be returned to a calling process.

FIG. **6** shows a flowchart for process **600** to provide preview data to a queue in accordance with at least one of the various embodiments. After a start block, at block **602**, in at least one of the various embodiments, preview data chunks may be generated from the data received from the preview data source.

At block **604**, in at least one of the various embodiments, the raw data may be tagged and/or marked to indicate that it may be intended for use as preview data. Also, in at least one of the various embodiments, the current candidate configuration information may be associated with the preview data.

In at least one of the various embodiments, raw data may be arranged and/or processed in chunks, packets, streams, or the like. In at least one of the various embodiments, tag and/or mark each raw data chunk that may include preview data as preview data chunks.

At block **606**, in at least one of the various embodiments, submit the preview data to one or more queues so worker agents may retrieve the preview data from the queues and transfer it to a pipeline for further processing based on the associated candidate configuration information. Next, in at least one of the various embodiments, control may be returned to a calling process.

FIG. **7** shows a flowchart for process **700** for processing data in a pipeline in accordance with at least one of the various embodiments. After a start block, at block **702**, in at least one of the various embodiments, generate index data from raw data that may be in the pipeline and/or generate preview index data from the preview data.

In at least one of the various embodiments, preview index data may be generated by an indexer application that processes preview data from preview data sources. Also, index data may be generated by an indexer application that processes raw data from non-preview data sources. In at least one of the various embodiments, an indexer application may take raw data and apply the configuration information to generate index data corresponding to the source of the raw data and/or the type of results expected/desired to be included in the index.

Also, in at least one of the various embodiments, index data chunks may be generated by an indexer application that processes raw data chunks from preview data sources and/or production (non-preview) data sources. In at least one of the various embodiments, an indexer application may take raw data chunks and apply one or more sets of configuration information to generate index data chunks corresponding to the raw data chunk and/or the type of results expected/desired to be included in the index.

For example, in at least one of the various embodiments, if raw data includes information from web server access logs, an indexer application may be configured to extract properties and features known to be included in web server

log file records, such as, http methods, URLs, HTTP headers (e.g., user-agent, cookie, referrer, or the like), response codes, or the like.

At decision block **704**, in at least one of the various embodiments, if the generated index data may be from preview data (e.g., originating from a preview data source), control may move to block **706**. Otherwise, in at least one of the various embodiments, control may move to block **710**.

In at least one of the various embodiments, a previewing application may determine if an preview index data chunk is associated with preview data chunks by determining if there is an indicative tag and/or marker in the preview index data chunk.

At block **706**, in at least one of the various embodiments, generate preview result data from the preview index data. In at least one of the various embodiments, preview result data may be generated by executing one or more search commands and/or query commands against the data included in the preview data chunk and the preview index data.

At block **708**, in at least one of the various embodiments, the generated preview search results data may be stored into a preview data store. In at least one of the various embodiments, a preview data store may be separate from the index stores.

In at least one of the various embodiments, storing the preview results data in the preview data store may preserve the preview results enabling users to retrieve and view the results. In at least one of the various embodiments, the previewing application may enable the stored previews results to be viewed using client applications, including previewing application **322** that may be operative on client devices, such as mobile device **300**. In at least one of the various embodiments, preview results data may be viewed in graphical user-interfaces that enable users to view the effectiveness of the candidate configuration information that may have been employed to generate the preview results.

In at least one of the various embodiments, the progress of the previewing process may be tracked enabling relevant metrics related to the on going previewing process to be generated and displayed to a user. In at least one of the various embodiments, progress may be tracked by monitoring the number of preview index data chunks that may be generated by the indexer application. In at least one of the various embodiments, a metric based on the ratio of the number of preview index data chunks that have been written to the preview store to the number of preview index data chunks needed for presenting results may be calculated and displayed. In at least one of the various embodiments, the number of preview index data chunks needed for presenting preview results may vary. The number of preview index data chunks required may depend on the type of preview data being processed and/or the type of preview results being generated. In at least one of the various embodiments, the particular configuration values for generating progress metrics (e.g., ratio denominators) may be supplied by a user and/or retrieved from the configuration information.

At block **710**, in at least one of the various embodiments, the processed index data may be added to one or more index data stores. In at least one of the various embodiments, production/non-preview index data produced by the indexer application may be routed to one or more production index stores to support search requests from users.

At decision block **712**, in at least one of the various embodiments, if there may be more data in the pipeline, control may loop back to block **702**. Otherwise, in at least one of the various embodiments, control may be returned to a calling process.

It will be understood that figures, and combinations of actions in the flowchart-like illustrations, can be implemented by computer program instructions. These program instructions may be provided to a processor to produce a machine, such that the instructions executing on the processor create a means for implementing the actions specified in the flowchart blocks. The computer program instructions may be executed by a processor to cause a series of operational actions to be performed by the processor to produce a computer implemented process for implementing the actions specified in the flowchart block or blocks. These program instructions may be stored on some type of machine readable storage media, such as processor readable nontransitive storage media, or the like.

Illustrative Indexing Preview Architecture

FIG. 8 illustrates for at least one of the various embodiments a logical overview of system 800 for previewing indexing. In at least one of the various embodiments, a search engine indexing system may be receiving data from one or more data sources, such as data sources 802-804, using one or more various input methods. In at least one of the various embodiments, data sources may include files, data streams, databases, or the like. Likewise, in at least one of the various embodiments, input methods may include reading files from disk, reading files from networked file systems, network connections to data streams, or the like.

In at least one of the various embodiments, data sources 802-804 may provide raw data that may be grouped/collected into data chunks that may be provided to one or more queues, such as queue 808. In at least one of the various embodiments, indexer application 422 may provide chunks of data from the data sources to queue 808.

In at least one of the various embodiments, processors, such as worker agents may transfer the received data chunks to the pipeline for processing.

In at least one of the various embodiments, appropriate worker agents (not shown) included in indexer application 422 may process the received data as it moves through pipeline 810. In at least one of the various embodiments, raw data may be received and/or processed in chunks, packets, streams, or the like. One of ordinary skill in the art will appreciate that the subject matter claimed herein applies whether the raw data, index data, preview data, or like, is received and/or arranged in chunks, packets, streams, or the like.

In at least one of the various embodiments, the worker agents may parse and process the received data chunks, such as data chunk 812, transforming the raw data into a form that is suitable for indexing (e.g., index data). In at least one of the various embodiments, if the data chunks may be processed and transformed into index data chunks without error, the index data chunks may be added to the appropriate index store, such as index store 822-824.

In at least one of the various embodiments, index stores 822-824 may include data organized to support search engine searches and/or queries. In at least one of the various embodiments, indexer application 422 may incrementally update the index stores as new index data is received from pipeline 810.

In at least one of the various embodiments, the worker agents may employ configuration information that provides rules and/or filters for influencing how the worker agents parse and organize the raw data chunks for indexing.

In at least one of the various embodiments, configuration information employed by the worker agents may be configured by users that have sufficient knowledge about the format of the raw data expected to be received from the data

sources. In at least one of the various embodiments, one or more different types of data may be received from the same data source. Thus, in at least one of the various embodiments, configuration information associated with a data source may include rules and filters appropriate for more than one type of data.

In at least one of the various embodiments, if pipeline 810 encounters data chunks that cause one or more errors to be generated during processing, each error may be logged and one or more users may be notified. Also, in at least one of the various embodiments, the raw data chunks and index data chunks associated with each error may be excluded from the one or more index stores until the error may be resolved.

However, in at least one of the various embodiments, data chunks that may be parsed incorrectly producing search results that are unexpected and/or undesired may not always generate a system error. In at least one of the various embodiments, worker agents may successfully process data chunks based on incorrect configuration information. For example, the configuration information may include filters that exclude data a user expects to be indexed. Or, in at least one of the various embodiments, improperly arranged configuration information may lack sufficient rules to extract and/or organize the raw data chunks as expected/desired by the user.

In at least one of the various embodiments, raw data chunks that may be improperly parsed because of improper configuration information may proceed through pipeline 810 and be added to an index store. In at least one of the various embodiments, the improperly processed index data may pollute an index, degrading the effectiveness and usefulness of the entire index store.

In at least one of the various embodiments, previewing application 424 may be employed to preview the effect of the configuration information on raw data chunks from a data source. In at least one of the various embodiments, the raw data chunks may be converted into preview index data chunks and previewed before being added to one or more index stores. This may enable, in at least one of the various embodiments, the effect of the rules and/or filters in the configuration information may be tested and observed without polluting the index stores.

In at least one of the various embodiments, previewing application 424 may be employed to determine a preview data source, such as preview source 806. In at least one of the various embodiments, a preview source may be a source of raw data that may be provided by various sources similar to data sources. Also, in at least one of the various embodiments, preview source 806 may provide data using various input methods similar to data sources 802-804. In at least one of the various embodiments, previewing application 424 may generate or determine candidate configuration data for the raw data received from preview source 806. In at least one of the various embodiments, previewing application 424 may attach/associate the configuration data to the raw preview data chunk before submitting the data chunk to queue 808.

In at least one of the various embodiments, previewing application 424 may retrieve a portion of the data available in preview source 806 for preview processing rather than retrieving all of the data available at the preview source. The portion size used for preview processing may be determined by a configuration rule that may be read from a user-interface, configuration file, database, or the like. For example, in at least one of the various embodiments, if a preview source includes a two gigabyte log file, the pre-

viewing application may be configured to read two megabytes of the file for preview processing.

In at least one of the various embodiments, preview application **424** may read data from the preview source until the received data may be detected to match the signature and/or pattern of known data types corresponding to other configuration information.

In at least one of the various embodiments, preview application **424** may enable a user to determine the parsing and field extraction rules from a set of available rules. Also, in at least one of the various embodiments, a user may create new and/or custom rules that build upon existing rules. In at least one of the various embodiments, a user may also generate new rules as well.

In at least one of the various embodiments, configuration information may be generated using a user-interface that provides access to one or more available rules. In some cases, rules that may be determined to closely match the data found in the preview data may be highlighted and/or presented in such a way to hint to the user that they may be relevant to previewing the data received from the preview source.

In at least one of the various embodiments, previewing application **424** may generate one or more preview data chunks from preview data source **806**. Further, in at least one of the various embodiments, previewing application **424** may associate the candidate configuration information with the preview data chunk. Also, in at least one of the various embodiments, the preview data chunk may be further tagged and/or marked by storing a value in the data chunk that identifies it as a preview data chunk.

In at least one of the various embodiments, if the candidate configuration information is associated with the one or more preview data chunks and they have been marked as preview data chunks, the previewing application may send the one or more data chunks to queue **808**.

In at least one of the various embodiments, preview data chunks may be processed in the pipeline similarly as non-preview data chunks. In at least one of the various embodiments, one or more worker agents may employ the configuration information associated with the preview data chunk that is being processed. Worker agents may employ the candidate configuration information to provide rules and information directing the worker agents how to parse and organize the received preview data chunks. In at least one of the various embodiments, the worker agents may employ the configuration information to control how the preview data chunks are parsed and organized for indexing.

In at least one of the various embodiments, data chunk **814** may include a header **816** and **818** data section. In at least one of the various embodiments, if data chunk **814** may be preview data chunk, header **816** may include a tag, key, or value that indicates that the data chunk is a preview data chunk. Also, in at least one of the various embodiments, header **816** may include a reference and/or pointer to the candidate configuration information that may be associated with the preview data chunk.

In at least one of the various embodiments, candidate configuration information may be included in header **816** or it may be included in another portion of the preview data chunk with an offset and/or reference pointing to the configuration information stored in the header.

In at least one of the various embodiments, data section **818** may include the raw data from the data source and/or it may contain the data as it is processed into index data by the various worker agents that work on the data chunk as it progresses through pipeline **810**.

In at least one of the various embodiments, as worker agents complete processing of the raw data chunks and preview data chunks into index data and preview index data, respectively, the data chunks may reach the end of the pipeline. In at least one of the various embodiments, the data chunks that exit the pipeline may be index data chunks and/or preview index data chunks that have been processed and formatted by various worker agents in accordance with the configuration information corresponding to each data chunk.

In at least one of the various embodiments, as the index data chunks reach the end of the pipeline, routing agent **820** may route the index data chunks to their respective index stores. For example, raw data chunks from data source **802** may be processed through pipeline **810** and routed to index store **822**. The determination of which data sources route to particular index stores may be a system configuration value set by a user or determined by the indexer application.

In at least one of the various embodiments, if routing agent **820** detects that a data chunk may be a preview index data chunk, the preview index data chunk may receive further processing. In at least one of the various embodiments, indexer application may execute a search string against the preview index data chunk to generate preview search results based on the preview index data chunks.

In at least one of the various embodiments, executing the search string may generate a collection of preview search result data that may be formatted the same as non-preview search results produced from non-preview index stores. In at least one of the various embodiments, the preview search results based on the preview index data chunks may be routed to preview store **826** for storage.

In at least one of the various embodiments, preview result store **826** may be accessed by users and/or client devices for viewing the preview search results in preview report views using graphical user-interfaces, web pages, consoles, or the like. In at least one of the various embodiments, if the user is unsatisfied with the results of the preview report views, the user may modify the candidate configuration information and resubmit the preview data for processing through pipeline **810**.

In at least one of the various embodiments, a user may iteratively modify the candidate configuration information and view the resulting preview reports until the user may be satisfied that the configuration information may produce satisfactory results if it is applied to data of the type in the preview data source.

In at least one of the various embodiments, if the user is satisfied with the configuration information, it may be committed to the indexing system for non-preview use. Also, in at least one of the various embodiments, data of the type held in the preview source may now be processed by the pipeline and routed to production index stores rather than being routed to a preview store.

In at least one of the various embodiments, the preview data source may include example data that corresponds to another live data source, or the preview data source may be a source of production data that may be indexed if the candidate configuration information is committed to the system.

In at least one of the various embodiments, configuration information may be associated with one or more data sources. In at least one of the various embodiments, if candidate configuration information may be committed, it may be available for associating with various data sources in the system.

It will be understood that for at least one of the various embodiments, various types of data may be received and processed as described and claimed herein. And, at least one of the various embodiments is not limited to processing machine data.

Having thus described the invention, what is claimed is:

1. A method, comprising:
 - accessing a portion of raw data from at least one data source;
 - causing display of one or more selectable parsing rules;
 - receiving a first user input, from a graphical user interface, selecting a parsing rule among the one or more selectable parsing rules, the parsing rule to be applied to the portion of raw data;
 - parsing the portion of raw data into one or more sets of parsed data using the parsing rule, each set of parsed data including raw data from the portion of raw data;
 - causing display of at least a portion of the one or more sets of parsed data;
 - receiving a second user input, from the graphical user interface, indicating a user preference to use a different parsing rule;
 - accessing a second parsing rule;
 - processing raw data from the at least one data source using the second parsing rule, to create searchable, time-stamped events, the processed raw data including the portion of raw data and additional raw data different from the portion of raw data; and
 - storing the searchable, time-stamped events in an index store, wherein the searchable, time-stamped events in the index store are used to service search queries received from a search engine;
 - wherein the method is performed by one or more computing devices.
2. The method of claim 1, wherein the parsing the portion of raw data further comprises:
 - causing display of the parsing rule.
3. The method of claim 1, wherein the display of the at least a portion of the one or more sets of parsed data includes an indication of how at least some of the portion of raw data has been parsed.
4. The method of claim 1, wherein one or more of the selectable parsing rules were created by a user based on existing parsing rules.
5. The method of claim 1, further comprising:
 - prior to receiving the first user input, causing display of the portion of raw data.
6. The method of claim 1, further comprising:
 - prior to receiving the first user input, causing display of the portion of raw data in a scrollable display.
7. The method of claim 1, wherein the causing the display of at least the portion of the one or more sets of parsed data displays the at least a portion of the one or more sets of parsed data in a scrollable display.
8. The method of claim 1, further comprising:
 - receiving a third user input, from the graphical user interface, selecting the second parsing rule.
9. One or more non-transitory storage media storing instructions which, when executed by one or more computing devices, cause operations comprising:
 - accessing a portion of raw data from at least one data source;
 - causing display of one or more selectable parsing rules;
 - receiving a first user input, from a graphical user interface, selecting a parsing rule among the one or more selectable parsing rules, the parsing rule to be applied to the portion of raw data;

- 5 parsing the portion of raw data into one or more sets of parsed data using the parsing rule, each set of parsed data including raw data from the portion of raw data;
 - causing display of at least a portion of the one or more sets of parsed data;
 - receiving a second user input, from the graphical user interface, indicating a user preference to use a different parsing rule;
 - accessing a second parsing rule;
 - 10 processing raw data from the at least one data source using the second parsing rule, to create searchable, time-stamped events, the processed raw data including the portion of raw data and additional raw data different from the portion of raw data; and
 - 15 storing the searchable, time-stamped events in an index store, wherein the searchable, time-stamped events in the index store are used to service search queries received from a search engine.
 10. The one or more non-transitory storage media of claim 9, wherein the parsing the portion of raw data further comprises causing display of the parsing rule.
 11. The one or more non-transitory storage media of claim 9, wherein the display of the at least a portion of the one or more sets of parsed data includes an indication of how at least some of the portion of raw data has been parsed.
 12. The one or more non-transitory storage media of claim 9, wherein one or more of the selectable parsing rules are user-created based on existing parsing rules.
 13. The one or more non-transitory storage media of claim 9, the operations further comprising prior to receiving the first user input received via the graphical user interface, causing display of the portion of raw data.
 14. The one or more non-transitory storage media of claim 9, the operations further comprising receiving a third user input, from the graphical user interface, selecting the second parsing rule.
 15. An apparatus, comprising:
 - a raw data selector, implemented at least partially in hardware, configured to access a portion of raw data from at least one data source;
 - a display subsystem, implemented at least partially in hardware, configured to cause display of one or more selectable parsing rules;
 - a user input receiver, implemented at least partially in hardware, configured to receive a first user input from a graphical user interface, selecting a parsing rule among the one or more selectable parsing rules, the parsing rule to be applied to the portion of raw data;
 - a raw data parser, implemented at least partially in hardware, configured to parse the portion of raw data into one or more sets of parsed data using the parsing rule, each set of parsed data including raw data from the portion of raw data;
 - wherein the display subsystem is configured to cause display of at least a portion of the one or more sets of parsed data;
 - wherein the user input receiver is configured to receive a second user input, from the graphical user interface, indicating a user preference to use a different parsing rule;
 - a parsing rule selector, implemented at least partially in hardware, configured to access a second parsing rule; wherein the raw data parser is configured to process, in response to receiving a second user input, raw data from the at least one data source using the second parsing rule, to create searchable, time-stamped

events, the processed raw data including the portion of raw data and additional raw data different from the portion of raw data; and

an event storage device, implemented at least partially in hardware, configured to store the searchable, time-stamped events in an index store, wherein the searchable, time-stamped events in the index store are usable to service search queries received from a search engine. 5

16. The apparatus of claim **15**, wherein the display subsystem is further configured to cause display of the parsing rule. 10

17. The apparatus of claim **15**, wherein the display subsystem is further configured to cause display of the at least a portion of the one or more sets of parsed data and includes an indication of how at least some of the portion of raw data has been parsed. 15

18. The apparatus of claim **15**, wherein one or more of the selectable parsing rules are user-created based on existing parsing rules.

19. The apparatus of claim **15**, wherein the display subsystem is further configured to cause, prior to receiving the first user input received via the graphical user interface, display of the portion of raw data. 20

20. The apparatus of claim **15**, wherein the user input receiver is further configured to receive a third user input, from the graphical user interface, selecting the second parsing rule. 25

* * * * *