

US010610374B2

(12) **United States Patent**
Shulock et al.

(10) **Patent No.:** **US 10,610,374 B2**
(45) **Date of Patent:** ***Apr. 7, 2020**

(54) **SELECTIVELY EXPANDING SPINE CAGE WITH ENHANCED BONE GRAFT INFUSION**

(71) Applicant: **Howmedica Osteonics Corp.**, Mahwah, NJ (US)

(72) Inventors: **Damien J. Shulock**, San Francisco, CA (US); **John E. Ashley**, Danville, CA (US); **Thomas Grotz**, Novato, CA (US); **Rudy Pretti**, Auburn, CA (US)

(73) Assignee: **Howmedica Osteonics Corp.**, Mahwah, NJ (US)

(*) Notice: Subject to any disclaimer, the term of this patent is extended or adjusted under 35 U.S.C. 154(b) by 0 days.

This patent is subject to a terminal disclaimer.

(21) Appl. No.: **15/807,835**

(22) Filed: **Nov. 9, 2017**

(65) **Prior Publication Data**

US 2018/0064557 A1 Mar. 8, 2018

Related U.S. Application Data

(63) Continuation of application No. 14/689,634, filed on Apr. 17, 2015, now Pat. No. 9,814,600, which is a (Continued)

(51) **Int. Cl.**
A61F 2/44 (2006.01)
A61F 2/46 (2006.01)
(Continued)

(52) **U.S. Cl.**
CPC *A61F 2/4465* (2013.01); *A61F 2/441* (2013.01); *A61F 2/442* (2013.01); *A61F 2/4601* (2013.01);
(Continued)

(58) **Field of Classification Search**
CPC *A61F 2/4465*
See application file for complete search history.

(56) **References Cited**

U.S. PATENT DOCUMENTS

3,875,595 A 4/1975 Froning
4,932,975 A 6/1990 Main et al.
(Continued)

FOREIGN PATENT DOCUMENTS

EP 1442715 A3 11/2004
EP 1415624 B1 5/2006
(Continued)

OTHER PUBLICATIONS

International Search Report and Written Opinion dated Apr. 10, 2008 in related International Application No. PCT/US2007/079474.
(Continued)

Primary Examiner — Lynnsy M Summitt
Assistant Examiner — Tara Rose E Carter
(74) *Attorney, Agent, or Firm* — Lerner, David, Littenberg, Krumholz & Mentlik, LLP

(57) **ABSTRACT**

A selectively expanding spine cage has a minimized cross section in its unexpanded state that is smaller than the diameter of the neuroforamen through which it passes in the distracted spine. The cage conformably engages between the endplates of the adjacent vertebrae to effectively distract the anterior disc space, stabilize the motion segments and eliminate pathologic spine motion. Expanding selectively (anteriorly, along the vertical axis of the spine) rather than uniformly, the cage height increases and holds the vertebrae with fixation forces greater than adjacent bone and soft tissue failure forces in natural lordosis. Stability is thus achieved immediately, enabling patient function by eliminating painful motion. The cage shape intends to rest proximate to the anterior column cortices securing the desired
(Continued)

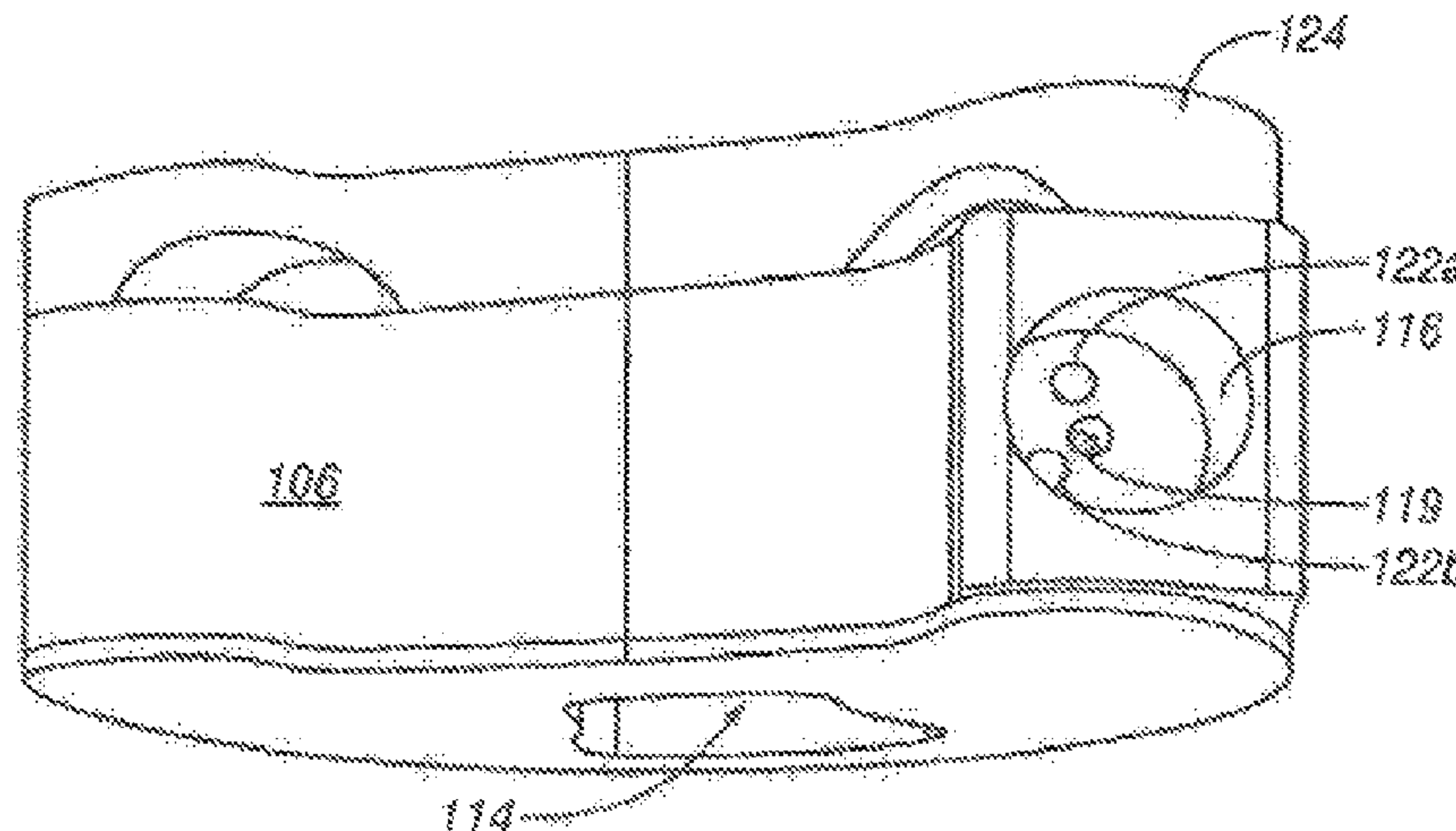

spread and fixation, allowing for bone graft in, around, and through the implant for arthrodesis whereas for arthroplasty it fixes to endpoints but cushions the spine naturally.

17 Claims, 15 Drawing Sheets

Related U.S. Application Data

continuation of application No. 13/799,047, filed on Mar. 13, 2013, now Pat. No. 9,028,550, which is a continuation-in-part of application No. 13/183,080, filed on Jul. 14, 2011, now Pat. No. 8,454,695, which is a continuation of application No. 11/535,432, filed on Sep. 26, 2006, now Pat. No. 7,985,256.

(60) Provisional application No. 60/720,784, filed on Sep. 26, 2005.

- (51) **Int. Cl.**
A61F 2/30 (2006.01)
A61F 2/28 (2006.01)
A61F 2/48 (2006.01)

- (52) **U.S. Cl.**
 CPC *A61F 2/4611* (2013.01); *A61F 2/30771* (2013.01); *A61F 2002/2835* (2013.01); *A61F 2002/3055* (2013.01); *A61F 2002/30062* (2013.01); *A61F 2002/30133* (2013.01); *A61F 2002/30235* (2013.01); *A61F 2002/30433* (2013.01); *A61F 2002/30538* (2013.01); *A61F 2002/30563* (2013.01); *A61F 2002/30579* (2013.01); *A61F 2002/30581* (2013.01); *A61F 2002/30583* (2013.01); *A61F 2002/30591* (2013.01); *A61F 2002/30593* (2013.01); *A61F 2002/30596* (2013.01); *A61F 2002/30598* (2013.01); *A61F 2002/30604* (2013.01); *A61F 2002/30617* (2013.01); *A61F 2002/30622* (2013.01); *A61F 2002/30772* (2013.01); *A61F 2002/30777* (2013.01); *A61F 2002/4475* (2013.01); *A61F 2002/4627* (2013.01); *A61F 2002/4629* (2013.01); *A61F 2002/4631* (2013.01); *A61F 2002/4666* (2013.01); *A61F 2002/485* (2013.01); *A61F 2210/0085* (2013.01); *A61F 2220/0041* (2013.01); *A61F 2230/0015* (2013.01); *A61F 2230/0069* (2013.01); *A61F 2250/0006* (2013.01); *A61F 2250/0097* (2013.01); *A61F 2310/00017* (2013.01); *A61F 2310/00023* (2013.01); *A61F 2310/00796* (2013.01)

(56) **References Cited**

U.S. PATENT DOCUMENTS

4,969,888	A	11/1990	Scholten et al.
5,236,460	A	8/1993	Barber
5,653,763	A	8/1997	Errico et al.
5,665,122	A	9/1997	Kambin
5,723,013	A	3/1998	Jeanson et al.
5,800,550	A *	9/1998	Sertich A61F 2/447 606/247
5,827,328	A	10/1998	Butterman
5,865,848	A	2/1999	Baker
5,916,267	A	6/1999	Tienboon
5,980,522	A	11/1999	Koros et al.
5,989,290	A	11/1999	Biedermann et al.
6,039,761	A	3/2000	Li et al.
6,102,950	A	8/2000	Vaccaro

6,127,597	A	10/2000	Beyar et al.
6,176,881	B1	1/2001	Schar et al.
6,193,756	B1	2/2001	Studer et al.
6,214,012	B1	4/2001	Karpman et al.
6,296,665	B1	10/2001	Strnad et al.
6,332,894	B1	12/2001	Stalcup et al.
6,371,989	B1	4/2002	Chauvin et al.
6,375,682	B1	4/2002	Fleischmann et al.
6,375,683	B1	4/2002	Crozet et al.
6,395,032	B1	5/2002	Gauchet
6,454,806	B1	9/2002	Cohen
6,562,074	B2 *	5/2003	Gerbec A61F 2/4455 623/17.15
6,582,467	B1	6/2003	Teitelbaum et al.
6,585,699	B2	7/2003	Ljunggreen et al.
6,692,495	B1	2/2004	Zacouto
6,719,796	B2	4/2004	Cohen et al.
6,723,126	B1	4/2004	Berry
6,730,088	B2	5/2004	Yeh
6,752,832	B2 *	6/2004	Neumann A61F 2/44 606/247
6,764,491	B2	7/2004	Frey et al.
6,830,570	B1	12/2004	Frey et al.
6,835,207	B2	12/2004	Zacouto et al.
6,866,682	B1	3/2005	An et al.
6,875,235	B2	4/2005	Ferree
6,953,477	B2	10/2005	Berry
6,960,232	B2	11/2005	Lyons et al.
6,981,989	B1	1/2006	Fleischmann et al.
7,001,431	B2	2/2006	Bao et al.
7,018,415	B1	3/2006	McKay
7,018,416	B2	3/2006	Hanson et al.
7,060,037	B2	6/2006	Lussier et al.
7,060,073	B2	6/2006	Frey et al.
7,066,958	B2	6/2006	Ferree
7,094,257	B2	8/2006	Mujwid et al.
7,166,110	B2	1/2007	Yundt
7,204,853	B2	4/2007	Gordon et al.
7,214,243	B2	5/2007	Taylor
7,217,293	B2	5/2007	Branch, Jr.
7,282,063	B2	10/2007	Cohen et al.
7,291,150	B2	11/2007	Graf
7,291,158	B2	11/2007	Crow et al.
7,316,686	B2	1/2008	Dorchak et al.
7,316,714	B2	1/2008	Gordon et al.
7,351,261	B2	4/2008	Casey
7,407,513	B2	8/2008	Alleyne et al.
7,419,505	B2	9/2008	Fleischmann et al.
7,452,359	B1	11/2008	Michelson
7,470,273	B2	12/2008	Dougherty-Shah
7,481,812	B2	1/2009	Frey et al.
7,485,145	B2	2/2009	Purcell
7,507,241	B2	3/2009	Levy et al.
7,520,900	B2	4/2009	Trieu
7,563,284	B2	7/2009	Coppes et al.
7,563,286	B2	7/2009	Gerber et al.
7,621,956	B2	11/2009	Paul et al.
7,628,815	B2	12/2009	Baumgartner et al.
7,670,359	B2	3/2010	Yundt
7,708,779	B2	5/2010	Edie et al.
7,722,674	B1	5/2010	Grotz
7,731,752	B2	6/2010	Edie et al.
7,731,753	B2	6/2010	Reo et al.
7,771,480	B2	8/2010	Navarro et al.
7,794,501	B2	9/2010	Edie et al.
7,806,935	B2	10/2010	Navarro et al.
7,819,921	B2	10/2010	Grotz
7,824,444	B2	11/2010	Biscup et al.
7,824,445	B2	11/2010	Biro et al.
7,854,766	B2	12/2010	Moskowitz et al.
7,862,618	B2	1/2011	White et al.
7,883,543	B2	2/2011	Sweeney
7,935,124	B2	5/2011	Frey et al.
7,967,863	B2	6/2011	Frey et al.
7,967,867	B2	6/2011	Barreiro et al.
7,985,231	B2	7/2011	Sankaran
7,985,256	B2	7/2011	Grotz et al.
8,021,395	B2	9/2011	Ben-Mokhtar et al.
8,025,680	B2	9/2011	Hayes et al.

(56)

References Cited

U.S. PATENT DOCUMENTS

8,057,549 B2 11/2011 Butterman et al.
 8,062,368 B2 11/2011 Heinz et al.
 8,062,373 B2 11/2011 Fabian, Jr.
 8,070,813 B2 12/2011 Grotz et al.
 8,105,382 B2 1/2012 Olmos et al.
 8,153,785 B2 4/2012 Khire et al.
 8,187,331 B2 5/2012 Strohkirch, Jr. et al.
 8,192,495 B2 6/2012 Simpson et al.
 8,267,939 B2 9/2012 Cipoletti et al.
 8,273,124 B2 9/2012 Renganath et al.
 8,353,961 B2 1/2013 McClintock et al.
 8,366,777 B2 2/2013 Matthis et al.
 8,394,143 B2 3/2013 Grotz et al.
 8,435,296 B2 5/2013 Kadaba et al.
 8,454,695 B2 6/2013 Grotz et al.
 8,696,751 B2 4/2014 Ashley et al.
 2001/0056302 A1 12/2001 Boyer et al.
 2002/0099444 A1 7/2002 Boyd et al.
 2002/0128716 A1 9/2002 Cohen et al.
 2002/0136146 A1 9/2002 Lee et al.
 2002/0138146 A1 9/2002 Jackson
 2002/0151976 A1 10/2002 Foley et al.
 2003/0114899 A1 6/2003 Woods et al.
 2003/0130739 A1 7/2003 Gerbec et al.
 2004/0030346 A1 2/2004 Frey et al.
 2004/0088054 A1 5/2004 Berry
 2004/0097928 A1 5/2004 Zdeblick et al.
 2004/0133273 A1 7/2004 Cox
 2004/0181229 A1 9/2004 Michelson
 2004/0186569 A1* 9/2004 Berry A61F 2/44
 623/17.11
 2004/0186576 A1 9/2004 Biscup et al.
 2005/0033437 A1 2/2005 Bao et al.
 2005/0043800 A1 2/2005 Paul et al.
 2005/0049590 A1 3/2005 Alleyne et al.
 2005/0085910 A1 4/2005 Sweeney
 2005/0107881 A1 5/2005 Alleyne et al.
 2005/0113842 A1 5/2005 Bertagnoli et al.
 2005/0197702 A1 9/2005 Coppes et al.
 2005/0216084 A1 9/2005 Fleischmann et al.
 2005/0229433 A1 10/2005 Cachia
 2005/0251260 A1 11/2005 Gerber et al.
 2005/0273169 A1 12/2005 Purcell
 2005/0273170 A1 12/2005 Navarro et al.
 2005/0273171 A1 12/2005 Gordon et al.
 2006/0036259 A1 2/2006 Carl et al.
 2006/0085073 A1 4/2006 Raiszadeh
 2006/0089719 A1 4/2006 Trieu
 2006/0106416 A1 5/2006 Raymond et al.
 2006/0116767 A1 6/2006 Magerl et al.
 2006/0142860 A1 6/2006 Navarro et al.
 2006/0149377 A1 7/2006 Navarro et al.
 2006/0167547 A1 7/2006 Suddaby
 2006/0200244 A1 9/2006 Assaker
 2006/0235426 A1 10/2006 Lim et al.
 2006/0235535 A1 10/2006 Ferree et al.
 2006/0264968 A1 11/2006 Frey et al.
 2007/0050030 A1 3/2007 Kim
 2007/0050033 A1 3/2007 Reo et al.
 2007/0073395 A1 3/2007 Baumgartner et al.
 2007/0093901 A1 4/2007 Grotz et al.
 2007/0093903 A1 4/2007 Cheng
 2007/0123987 A1 5/2007 Bernstein
 2007/0179611 A1 8/2007 DiPoto et al.
 2007/0233254 A1 10/2007 Grotz et al.
 2007/0255409 A1 11/2007 Dickson et al.
 2007/0255413 A1 11/2007 Edie et al.
 2007/0255415 A1 11/2007 Edie et al.
 2007/0270961 A1 11/2007 Ferguson
 2007/0270964 A1 11/2007 Strohkirch et al.
 2007/0288092 A1 12/2007 Bambakidis
 2008/0021555 A1 1/2008 White et al.
 2008/0021556 A1 1/2008 Edie
 2008/0058930 A1 3/2008 Edie et al.
 2008/0058931 A1 3/2008 White et al.

2008/0065082 A1 3/2008 Chang et al.
 2008/0065220 A1 3/2008 Alleyne et al.
 2008/0065221 A1 3/2008 Alleyne et al.
 2008/0077150 A1 3/2008 Nguyen
 2008/0086276 A1 4/2008 Naka et al.
 2008/0097441 A1 4/2008 Hayes et al.
 2008/0103601 A1 5/2008 Biro et al.
 2008/0114467 A1 5/2008 Capote et al.
 2008/0140207 A1 6/2008 Olmos et al.
 2008/0147193 A1 6/2008 Matthis et al.
 2008/0147194 A1 6/2008 Grotz et al.
 2008/0161933 A1 7/2008 Grotz et al.
 2008/0177387 A1 7/2008 Parimore et al.
 2008/0215153 A1 9/2008 Butterman et al.
 2008/0281424 A1 11/2008 Parry et al.
 2008/0288073 A1 11/2008 Renganath et al.
 2008/0300598 A1 12/2008 Barreiro et al.
 2009/0005819 A1 1/2009 Ben-Mokhtar et al.
 2009/0005874 A1 1/2009 Fleischmann et al.
 2009/0018661 A1 1/2009 Kim et al.
 2009/0043312 A1 2/2009 Koullisis et al.
 2009/0048676 A1 2/2009 Fabian, Jr.
 2009/0105836 A1 4/2009 Frey et al.
 2009/0171389 A1 7/2009 Sankaran
 2009/0204215 A1 8/2009 McClintock et al.
 2009/0216331 A1 8/2009 Grotz et al.
 2009/0222100 A1 9/2009 Cipoletti et al.
 2009/0270987 A1 10/2009 Heinz et al.
 2010/0057204 A1 3/2010 Kadaba et al.
 2010/0063510 A1 3/2010 Arlet et al.
 2010/0145455 A1 6/2010 Simpson et al.
 2010/0145456 A1 6/2010 Simpson et al.
 2011/0130835 A1 6/2011 Ashley et al.
 2011/0270398 A1 11/2011 Grotz et al.
 2011/0288646 A1 11/2011 Moskowitz et al.
 2012/0116518 A1 5/2012 Grotz et al.
 2012/0245695 A1 9/2012 Simpson et al.

FOREIGN PATENT DOCUMENTS

JP 2001276099 A 10/2001
 JP 2004522533 A 7/2004
 JP 2006506116 A 2/2006
 JP 2012523898 A 10/2012
 WO 2003003951 A1 1/2003
 WO 2004016250 A1 2/2004
 WO 2004016205 A3 5/2004
 WO 2006044786 A3 1/2007
 WO 2008011371 A3 3/2008
 WO 2007124078 A3 7/2008
 WO 2008039811 A3 7/2008
 WO 2008112607 A3 12/2008
 WO 2008148210 A1 12/2008
 WO 2009033100 A1 3/2009
 WO 2008121251 A3 8/2009
 WO 2009105182 A1 8/2009
 WO 2008086276 A3 12/2009
 WO 2010074704 A1 7/2010
 WO 2010068725 A3 10/2010
 WO 2010121149 A2 10/2010
 WO 2011150077 A1 12/2011

OTHER PUBLICATIONS

International Search Report and Written Opinion dated Jun. 5, 2009 for related PCT/US2009/000974.
 International Search Report and Written Opinion dated Aug. 13, 2010, in related International Application No. PCT/US2009/067446 filed Dec. 10, 2009.
 International Search Report and Written Opinion dated May 6, 2009, in related International Application No. PCT/US2009/000974 filed Feb. 17, 2009.
 International Search Report and Written Opinion dated Jun. 30, 2009, in related International Application No. PCT/US2008/003776 filed Mar. 21, 2008.
 International Search Report and Written Opinion dated Nov. 11, 2010, in International Application No. PCT/US2010/031247 entitled "Insertion Handle for Implant."

(56)

References Cited

OTHER PUBLICATIONS

International Search Report and Written Opinion dated Sep. 22, 2011 in related International Application No. PCT/US2011/037929.
International Search Report for PCT/US2007/079474 dated Apr. 10, 2008.

Written Opinion of the International Searching Authority for PCT/US2007/079474 dated Apr. 10, 2008.

Extended European Search Report for Application No. 14159365.7 dated Jun. 18, 2014.

Extended European Search Report for Application No. 17197747.3 dated May 4, 2018.

Office Action and Search Report for Application No. JP 2014-047766 dated Sep. 25, 2018, 3 pages.

Australian Search Report for Application No. 2018236854, dated Jun. 20, 2019, 1pg.

* cited by examiner

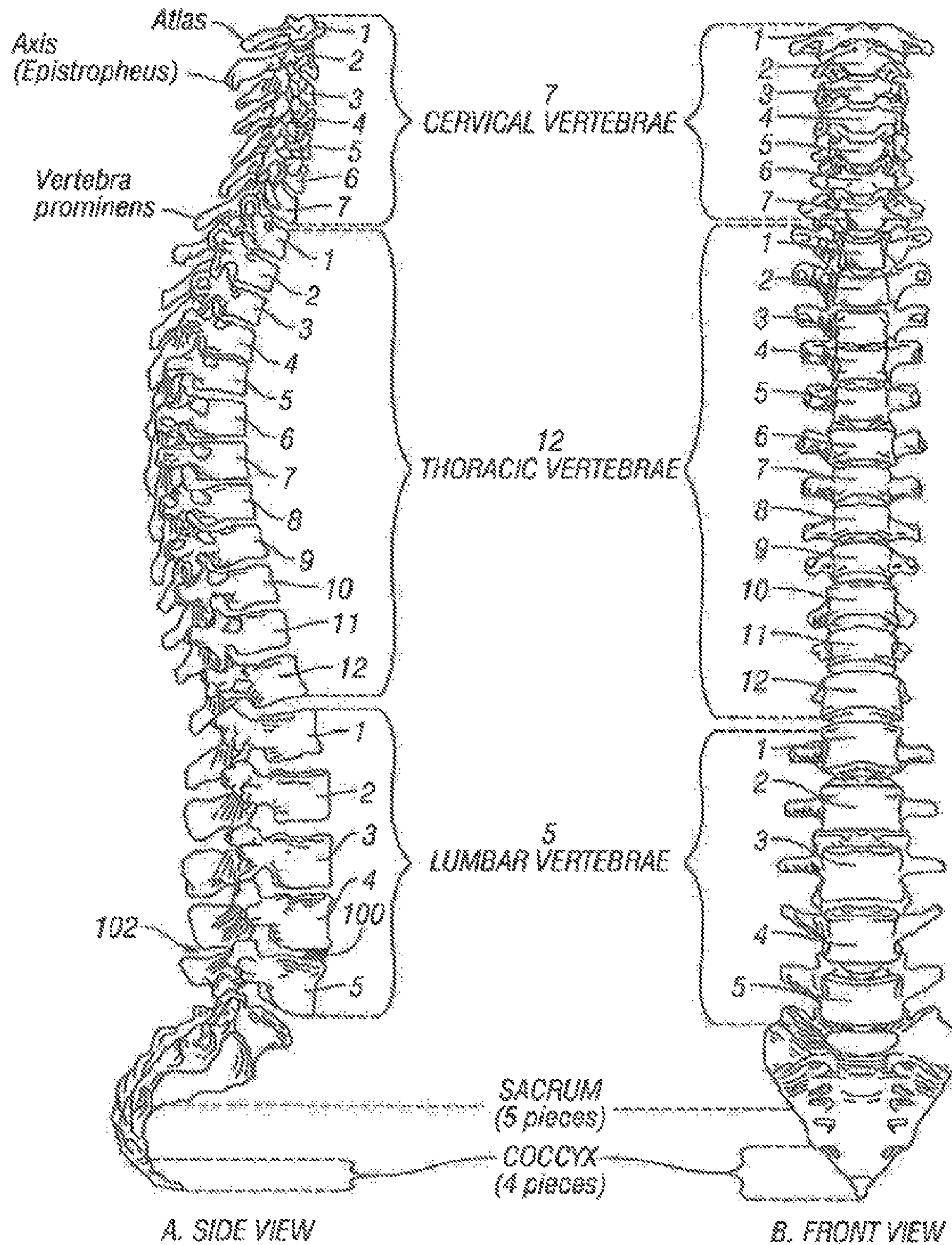

FIG. 1

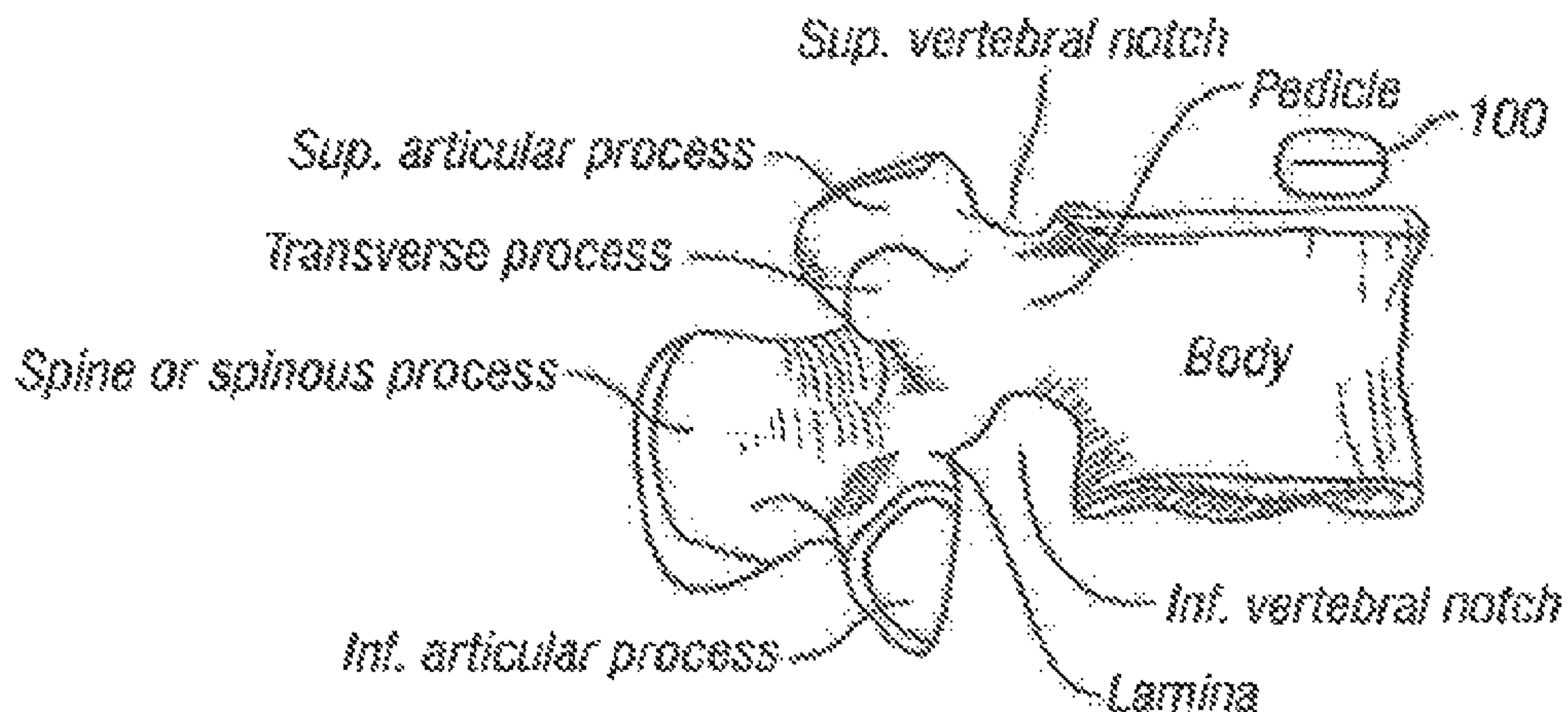

FIG. 2

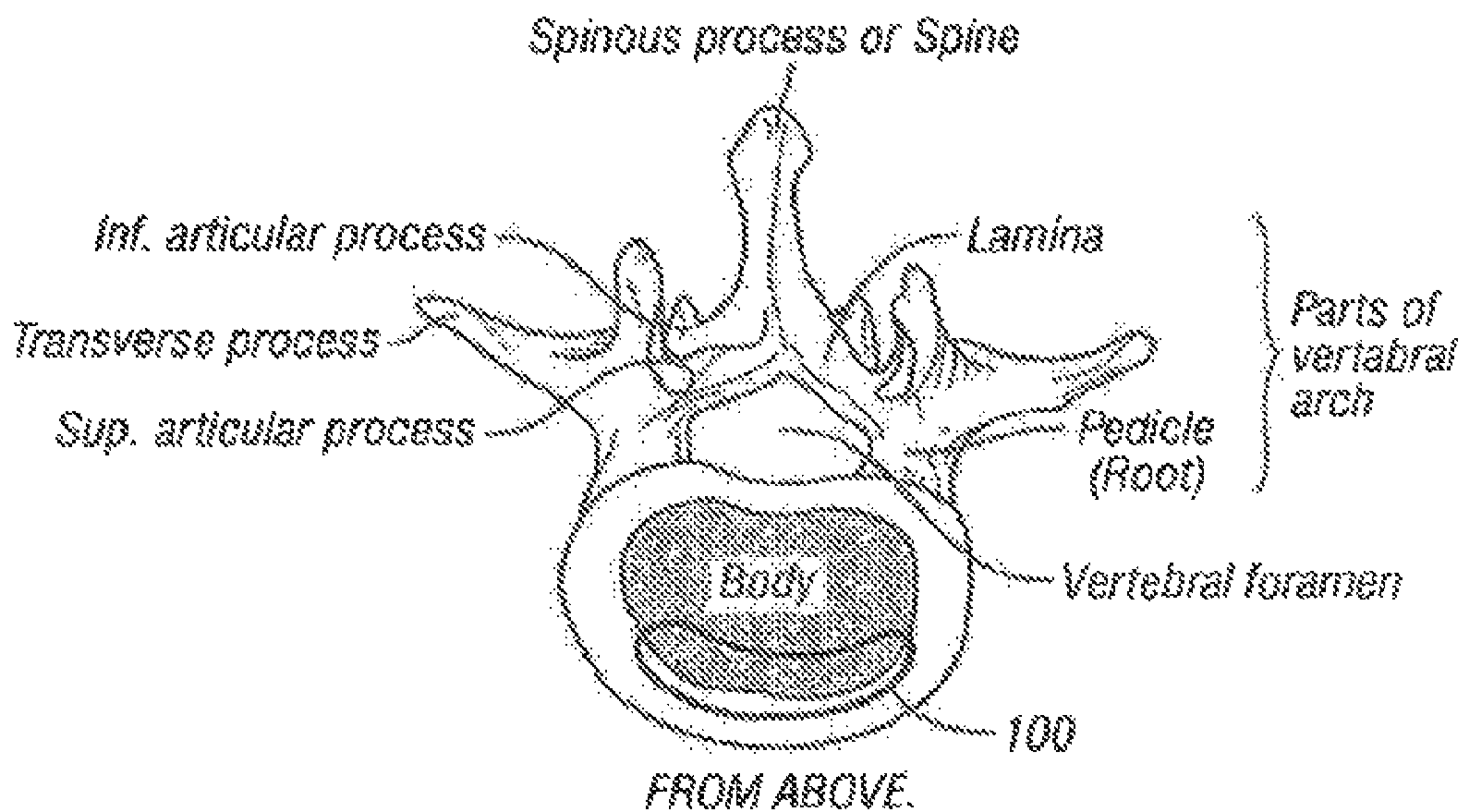

FIG. 3

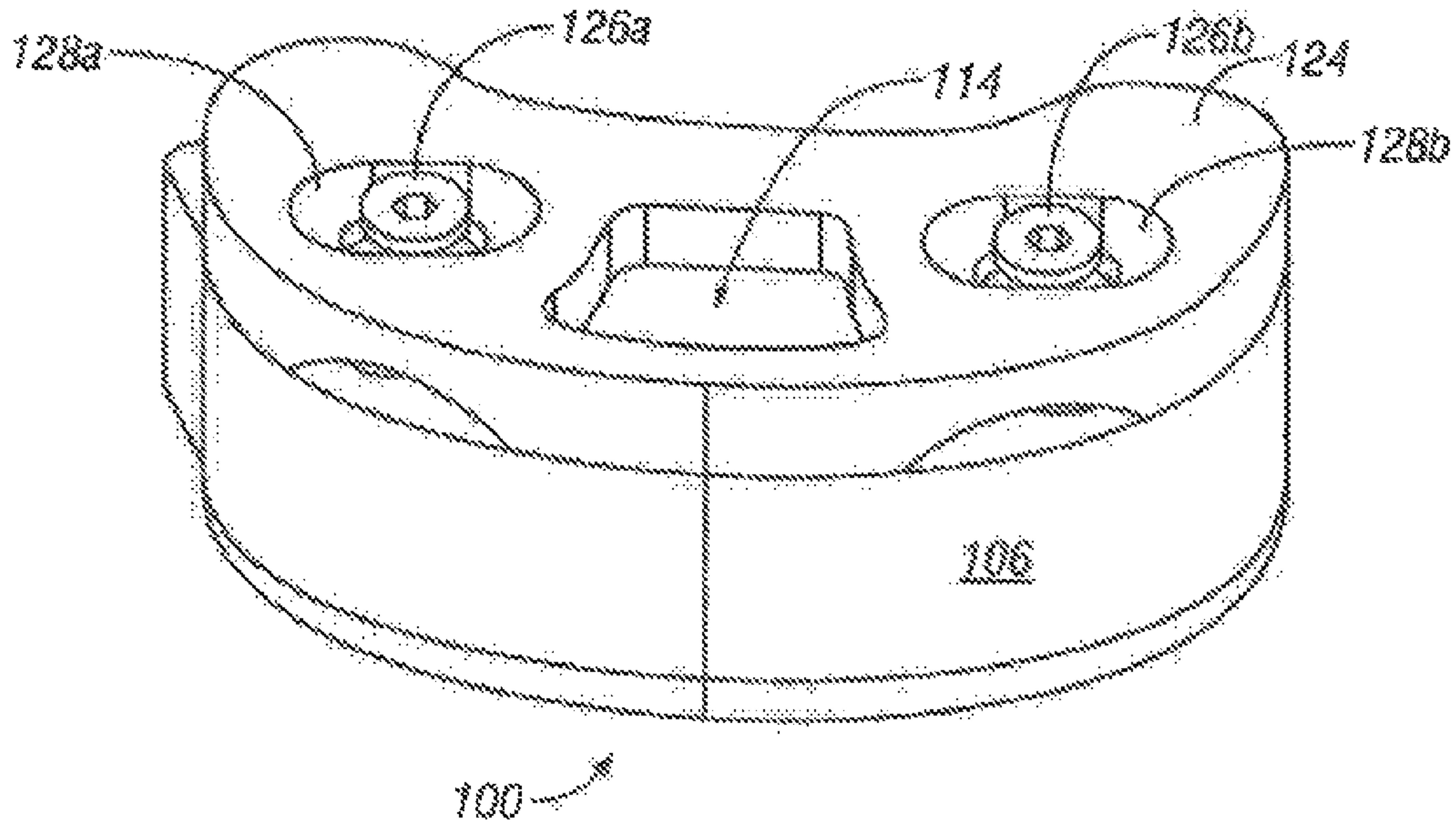

FIG. 4A

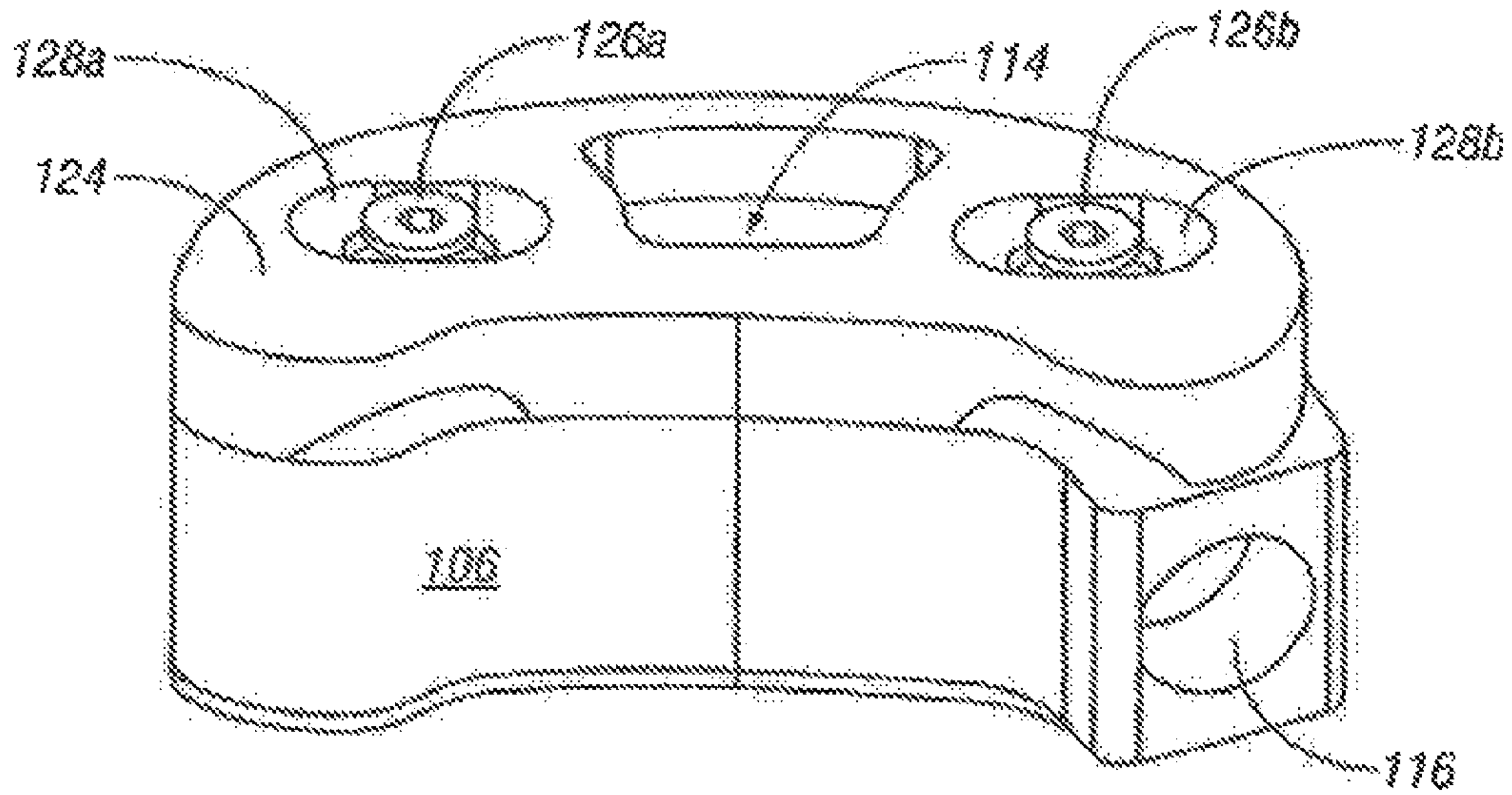

FIG. 4B

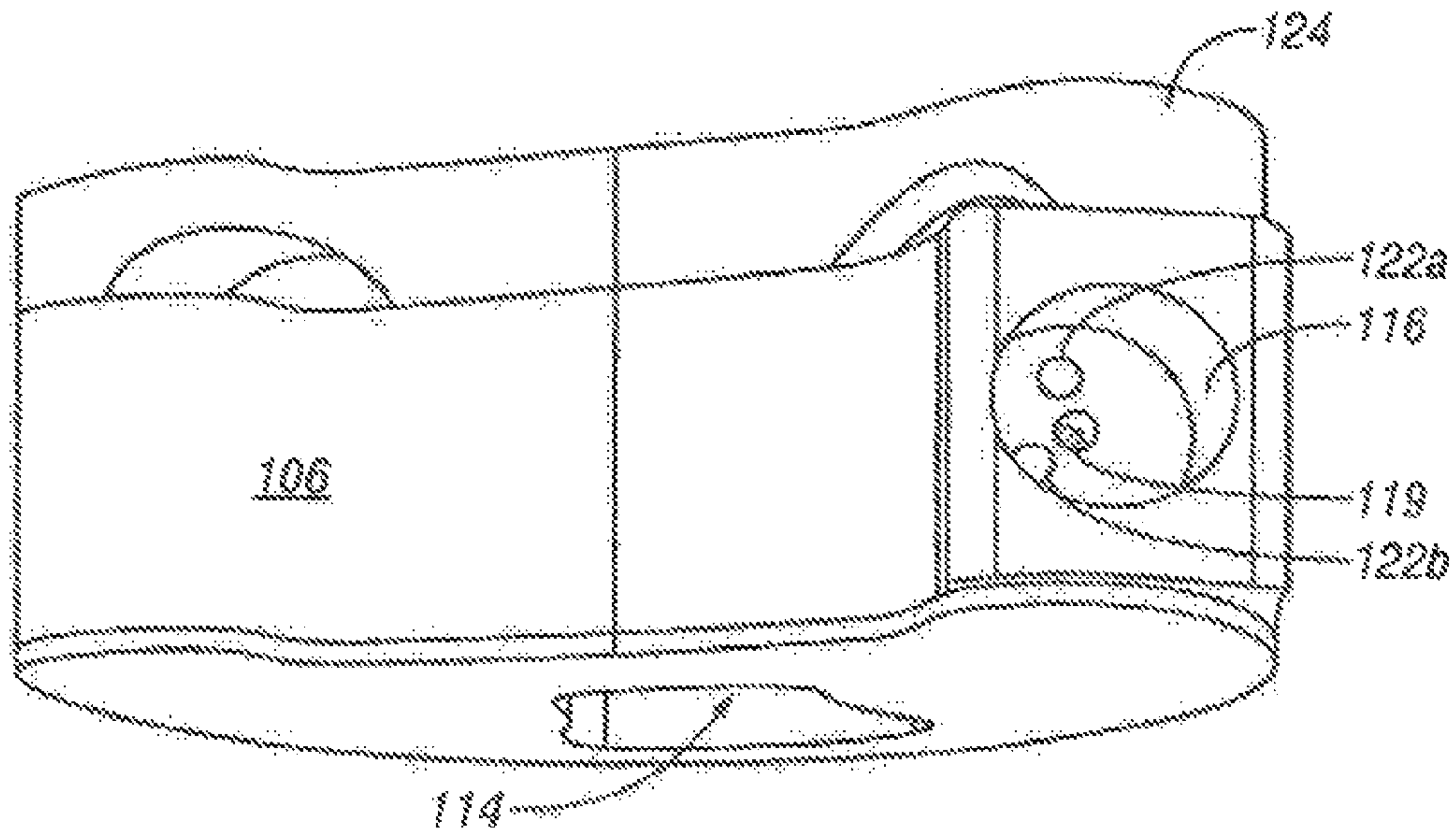

FIG. 4C

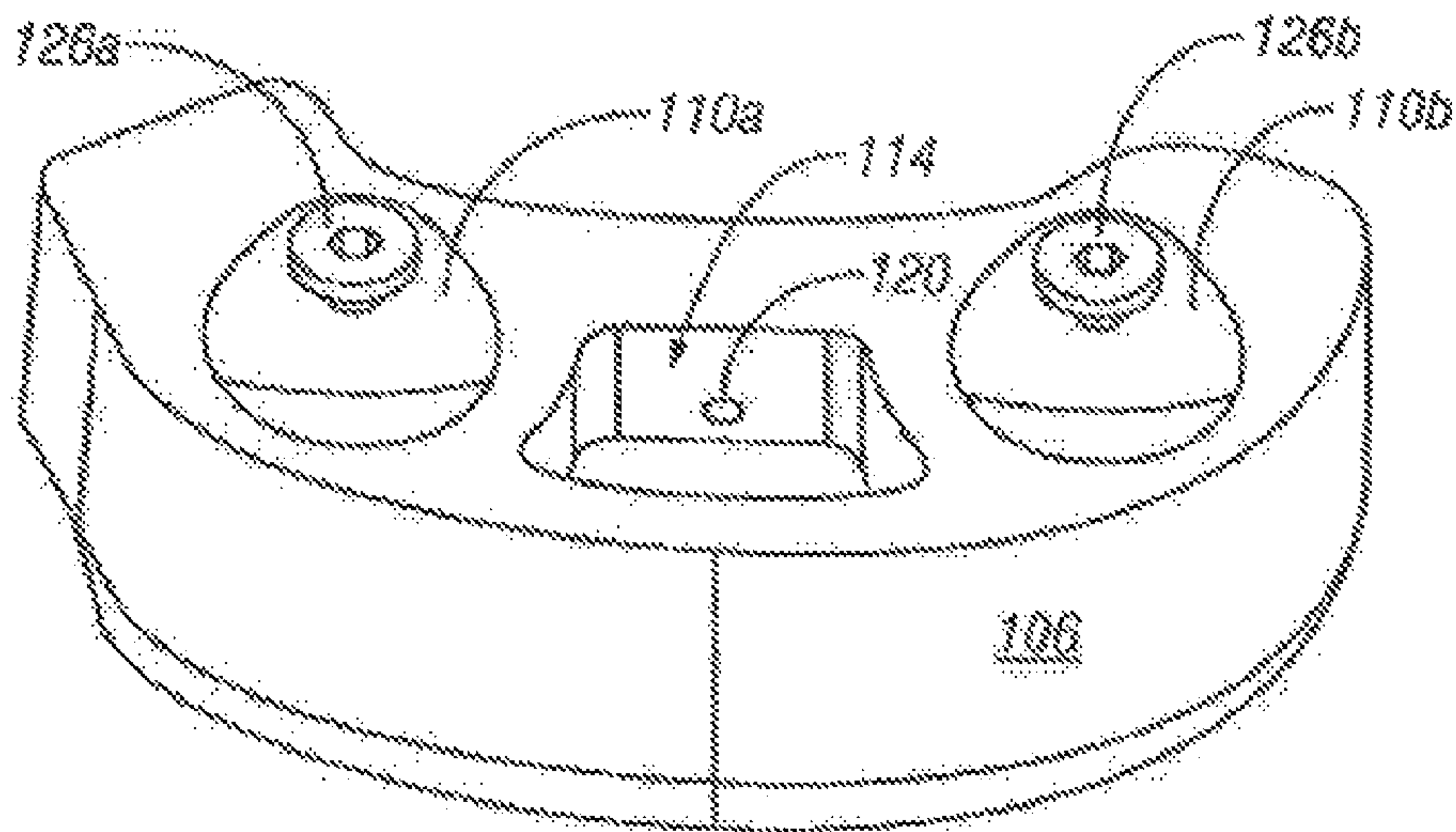

FIG. 4D

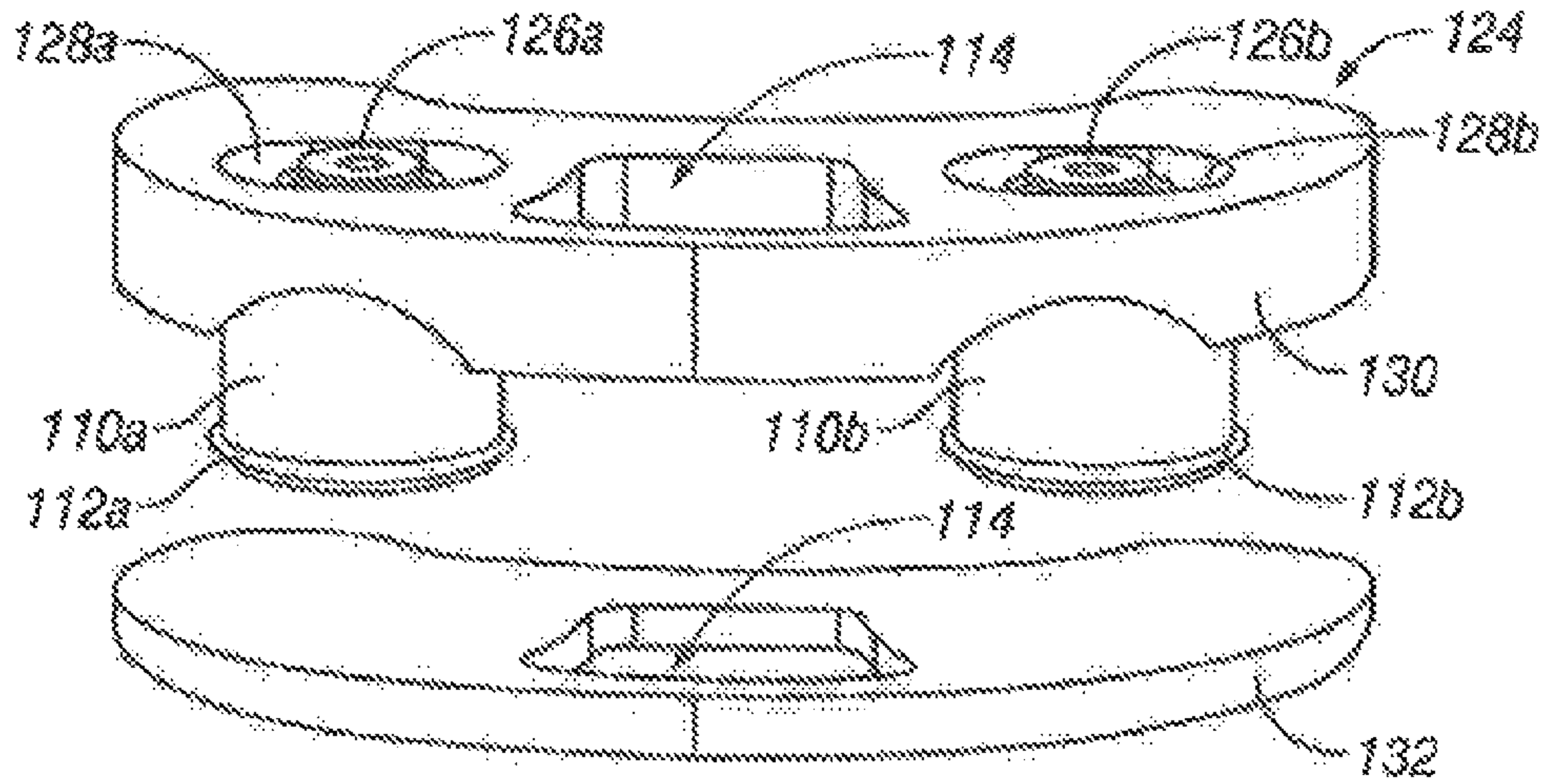

FIG. 4E

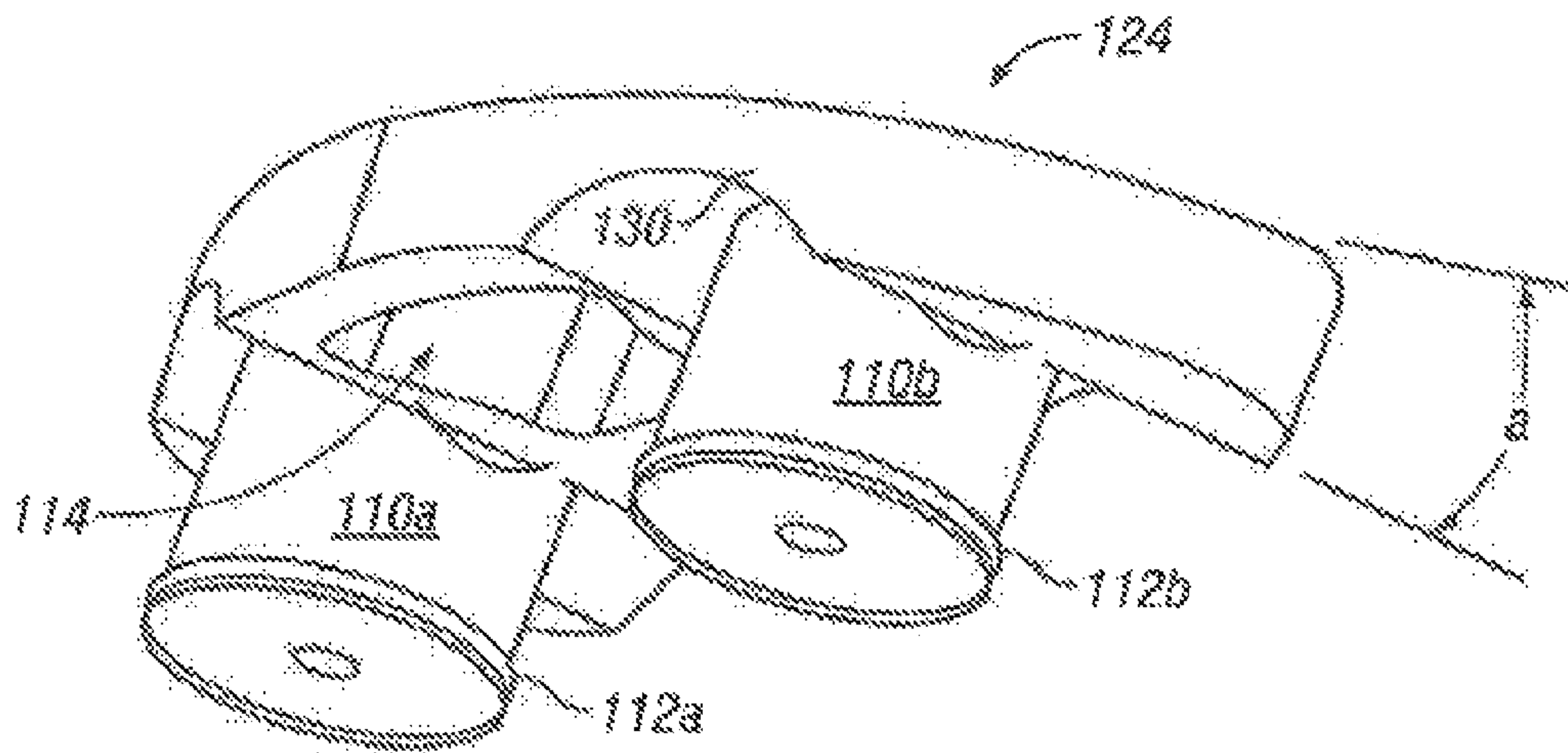

FIG. 4F

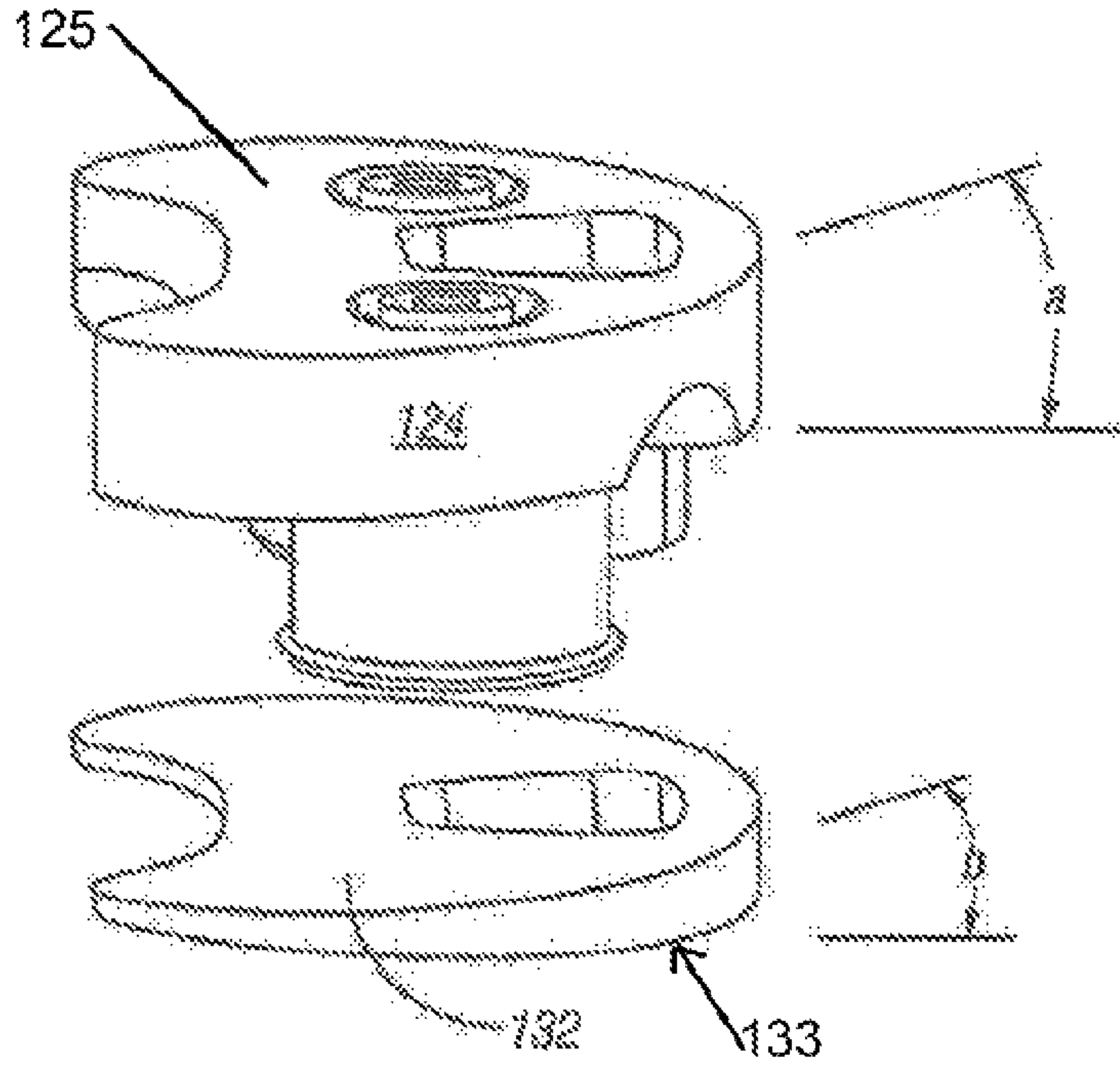

FIG. 4G

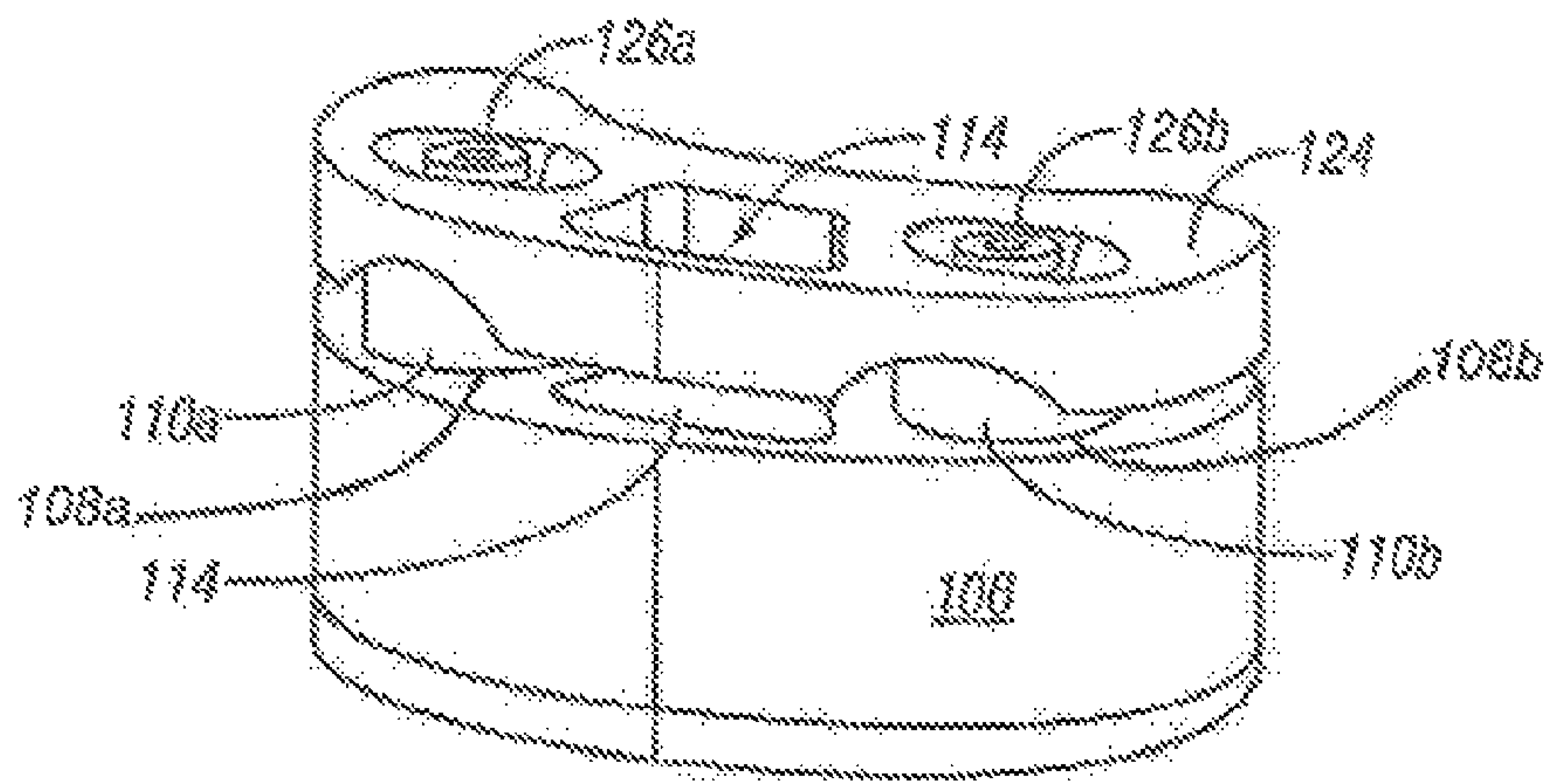

FIG. 5A

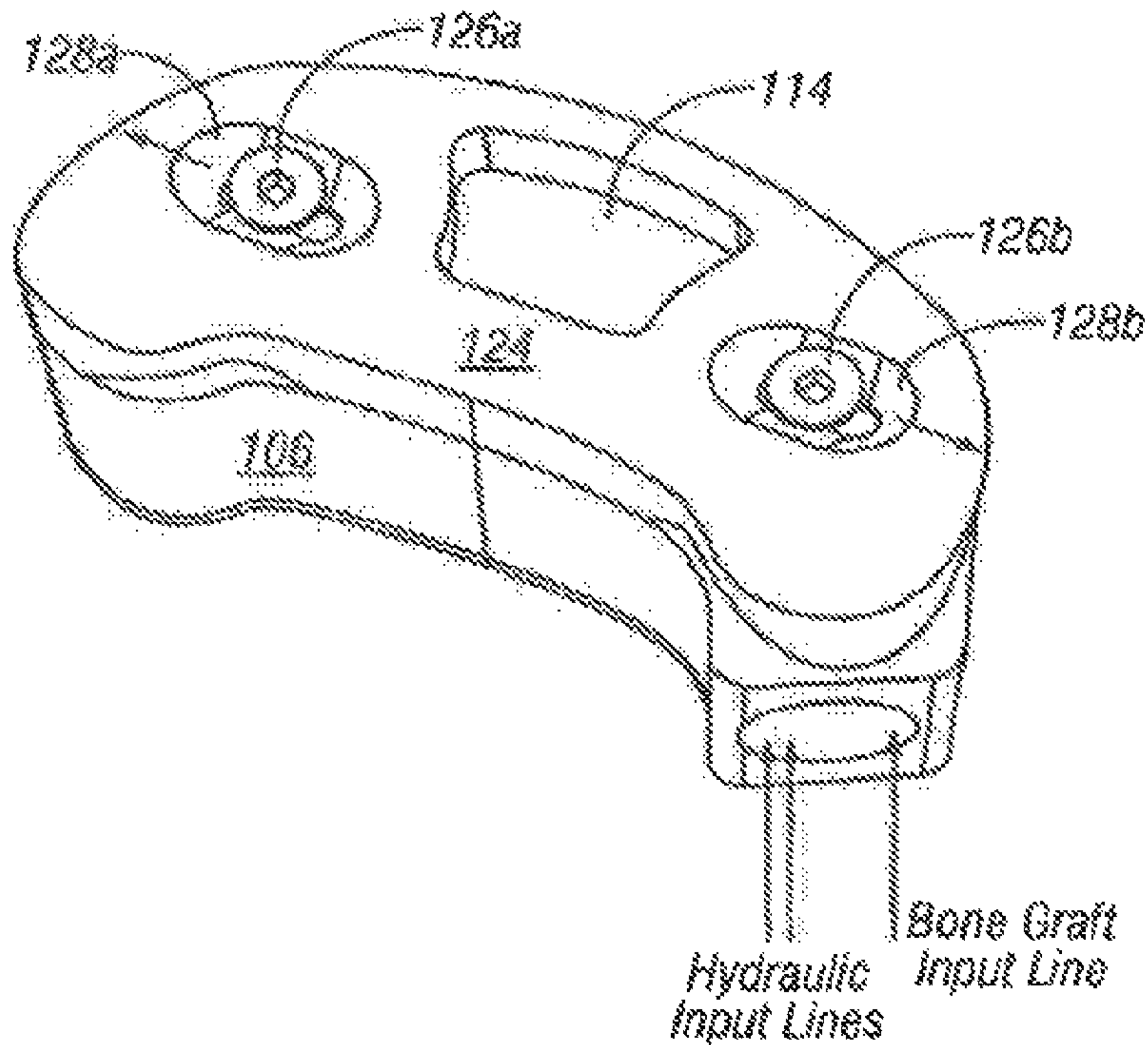

FIG. 5B

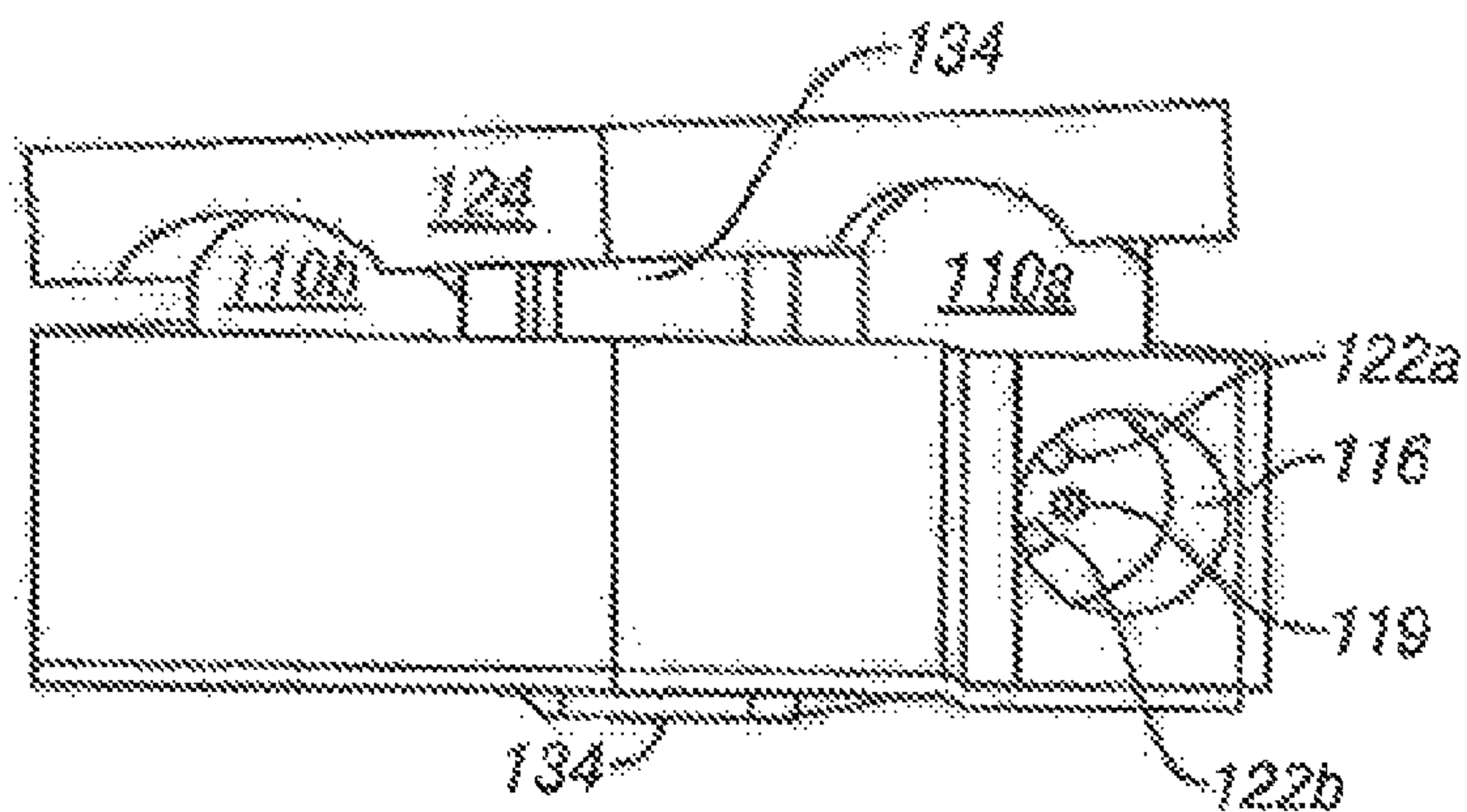

FIG. 5C

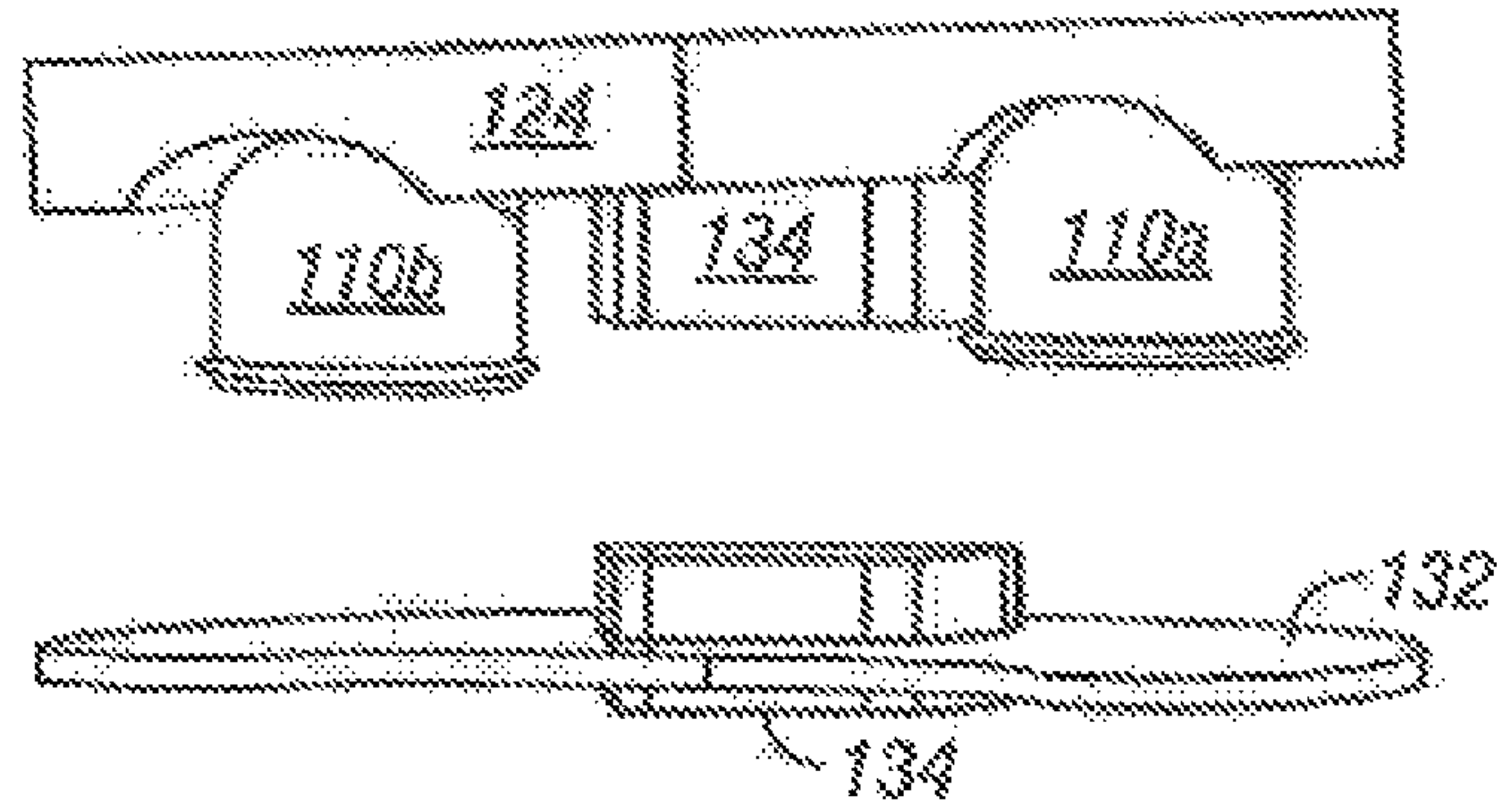

FIG. 5D

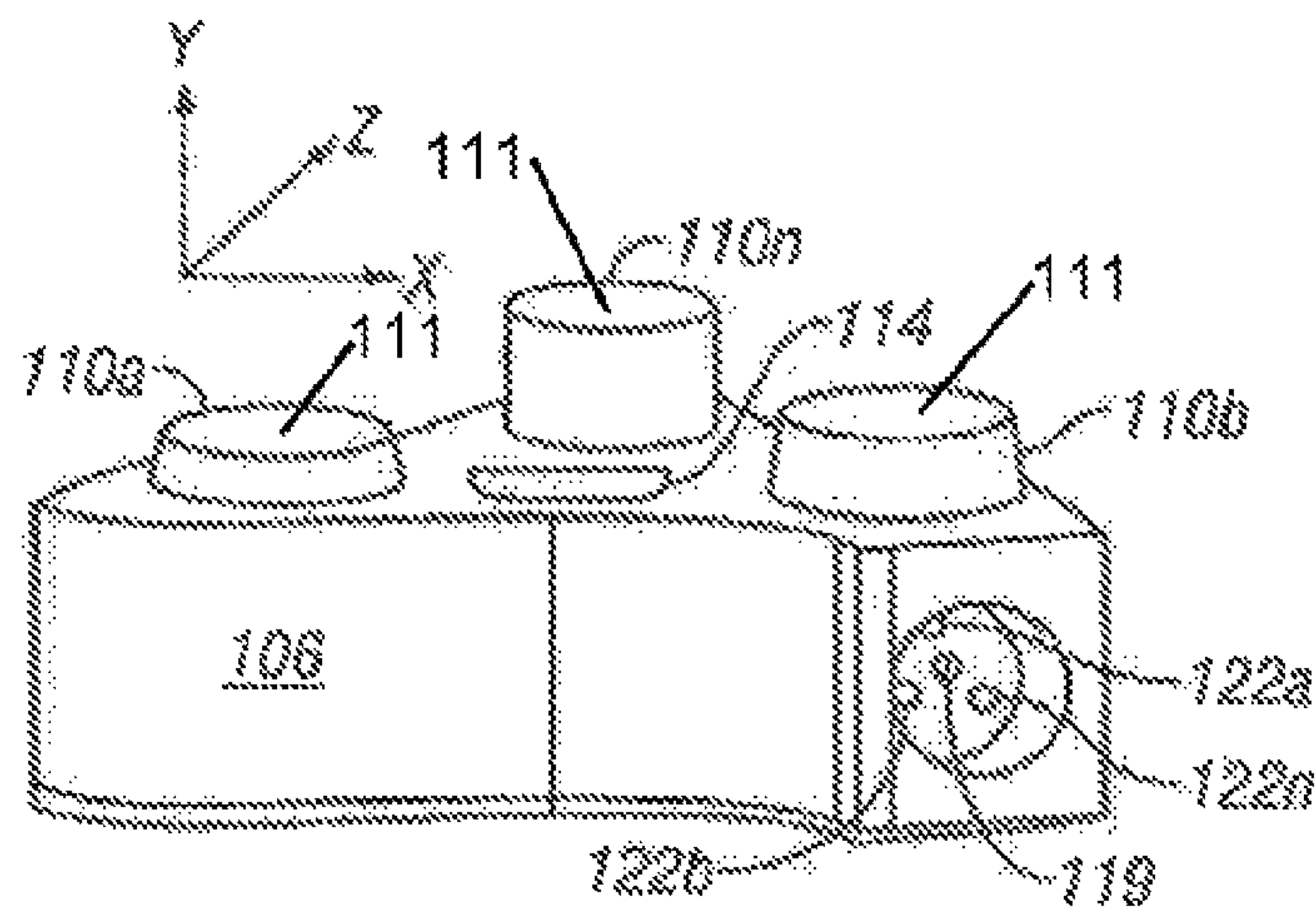

FIG. 6

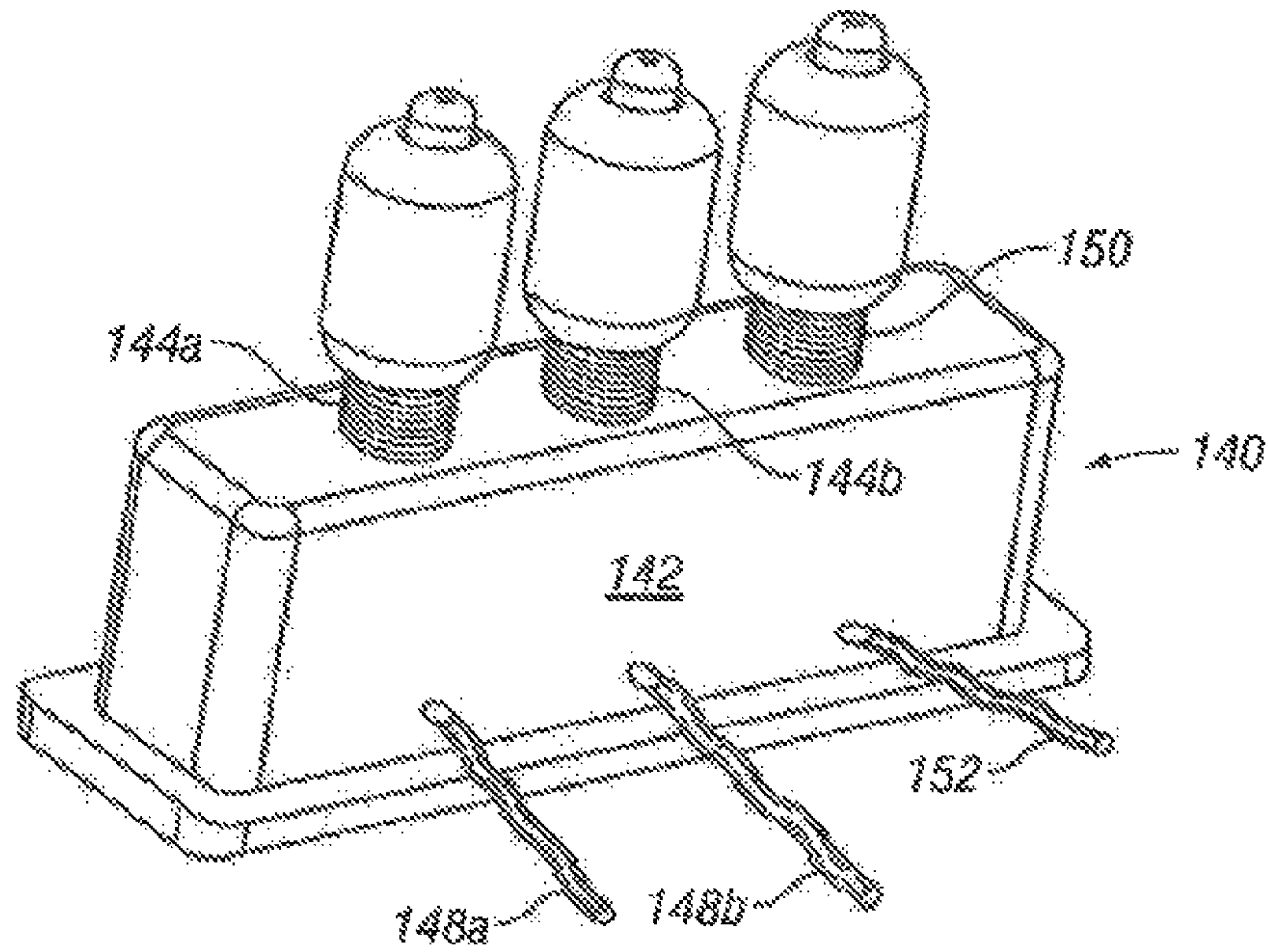

FIG. 7A

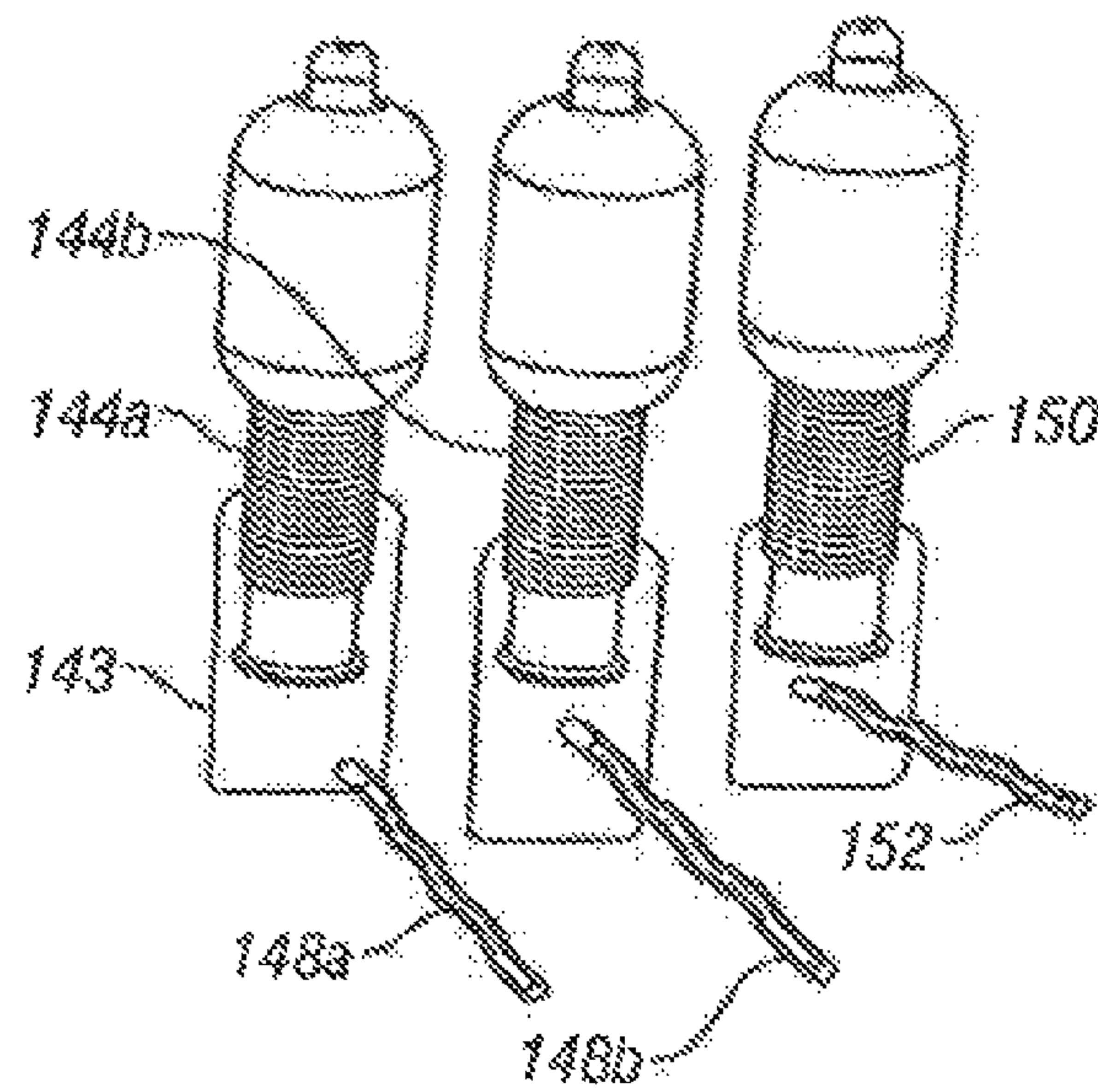

FIG. 7B

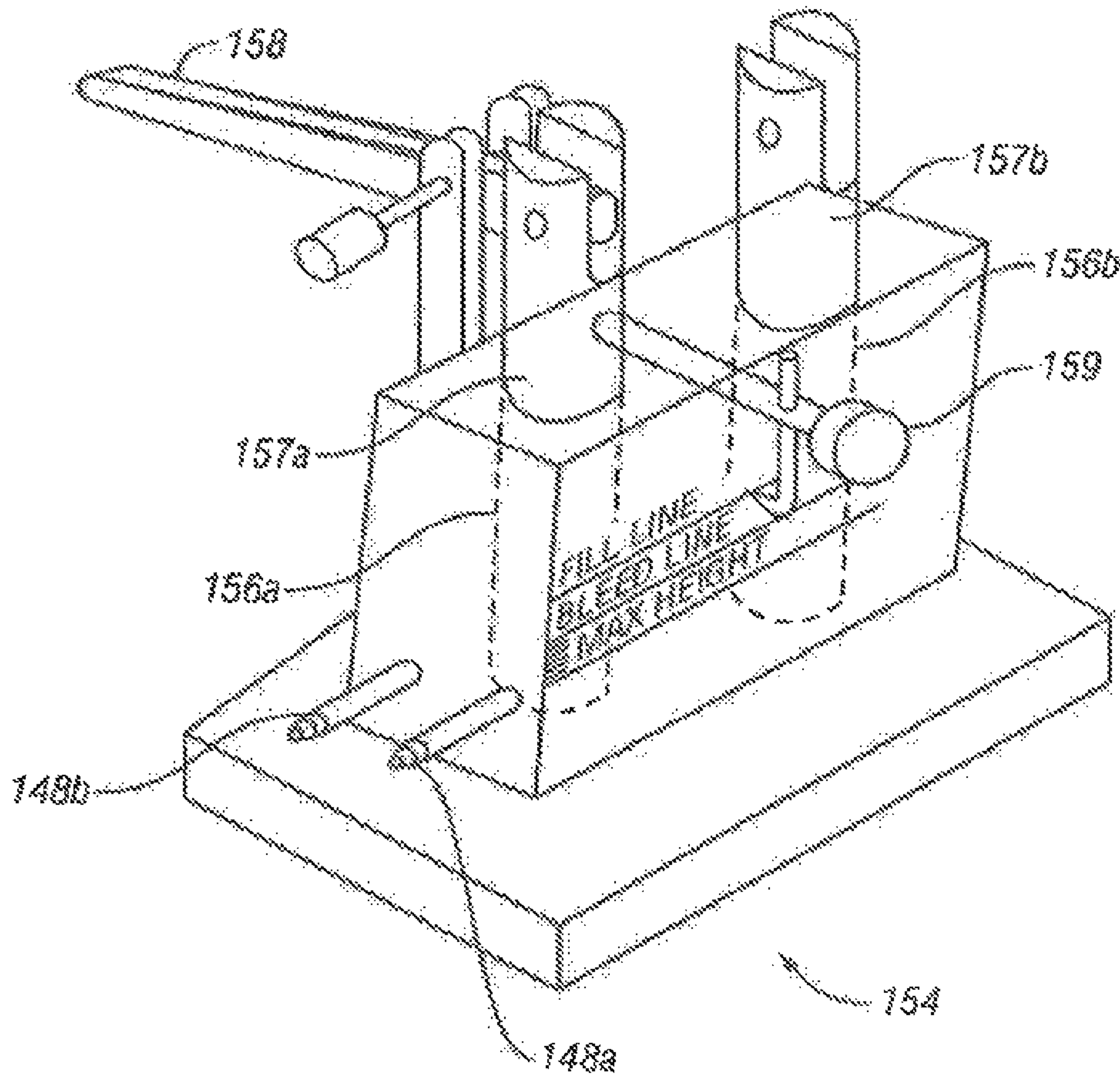

FIG. 8

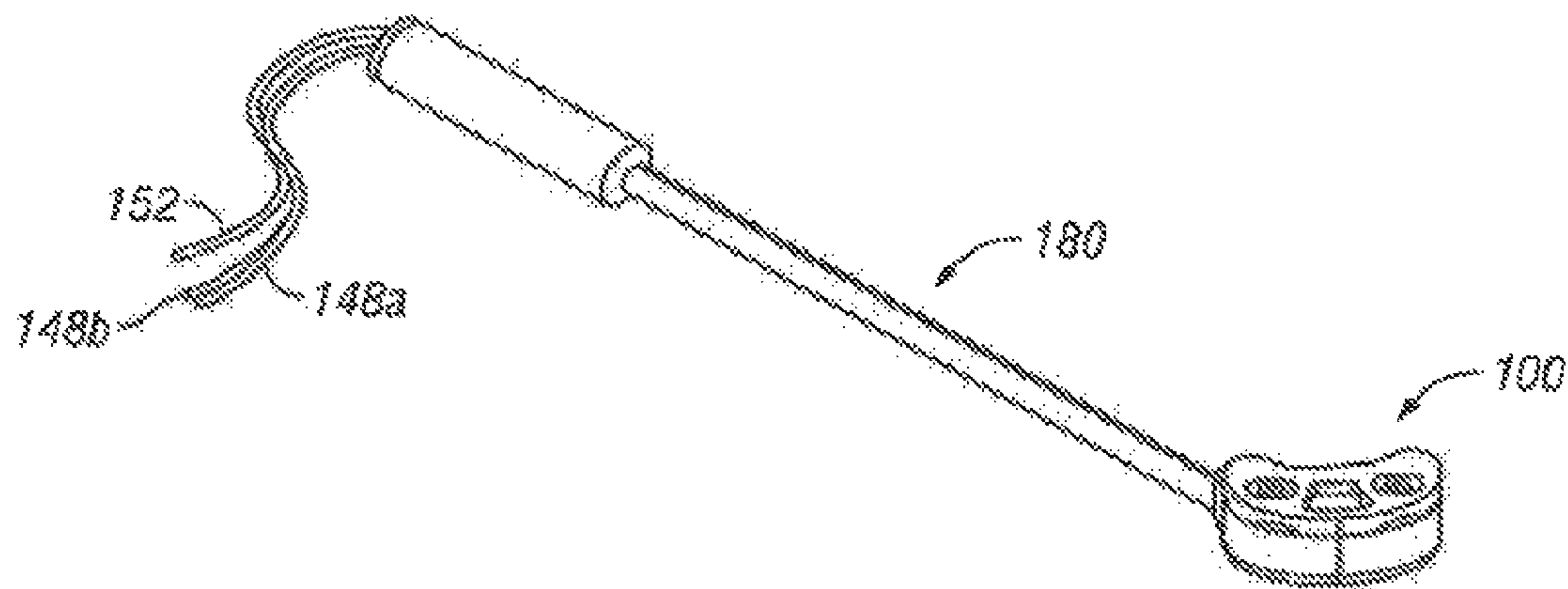

FIG. 9A

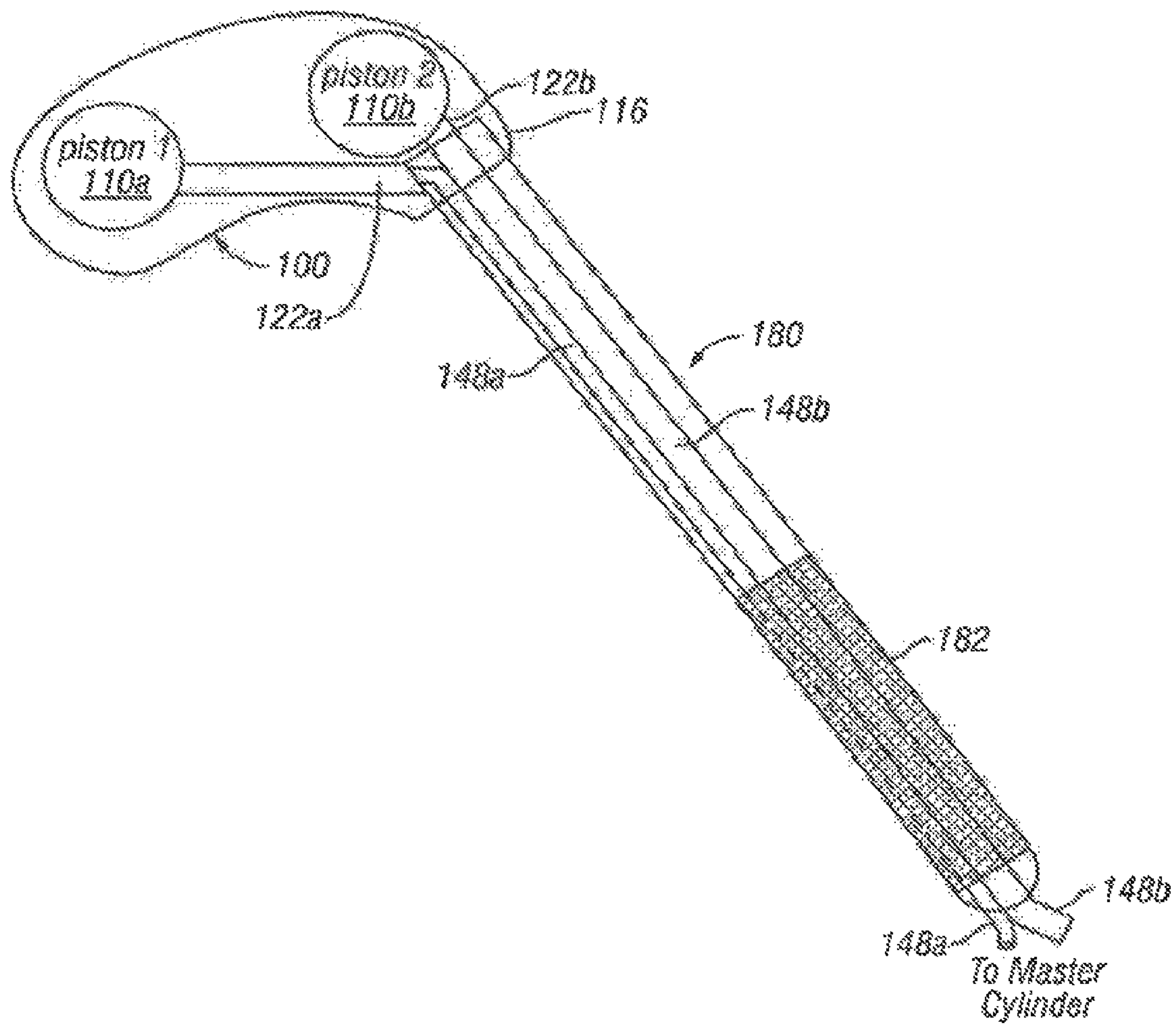

FIG. 9B

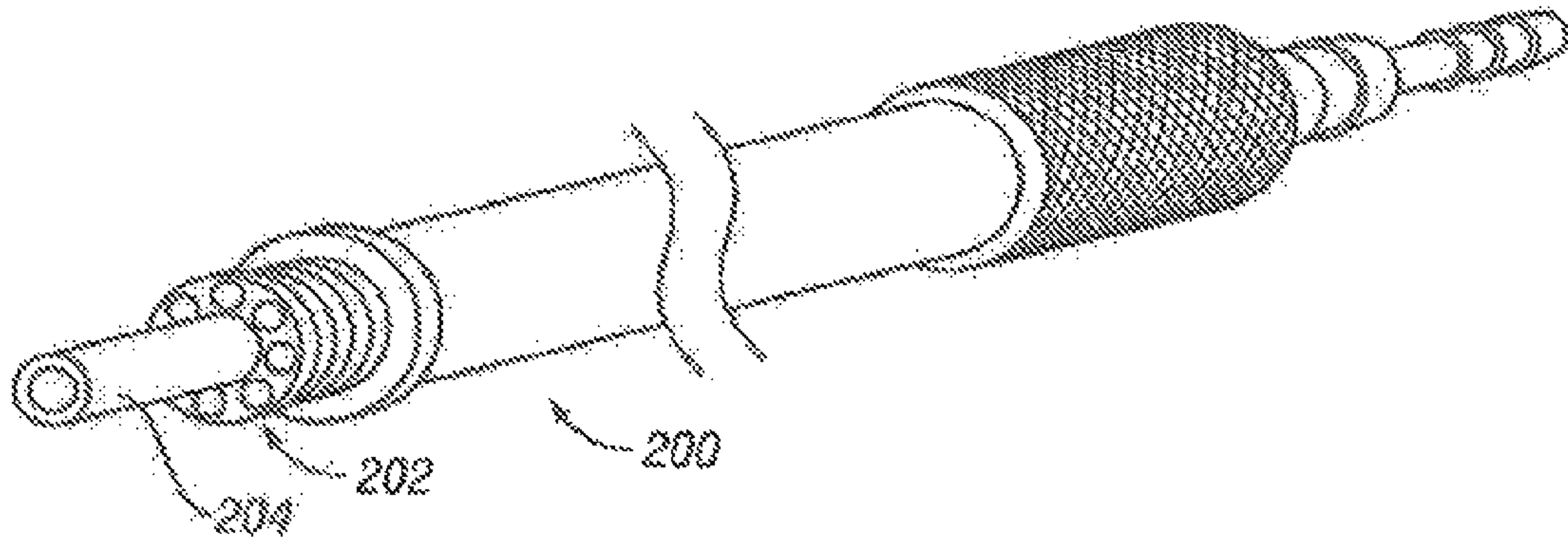

FIG. 10A

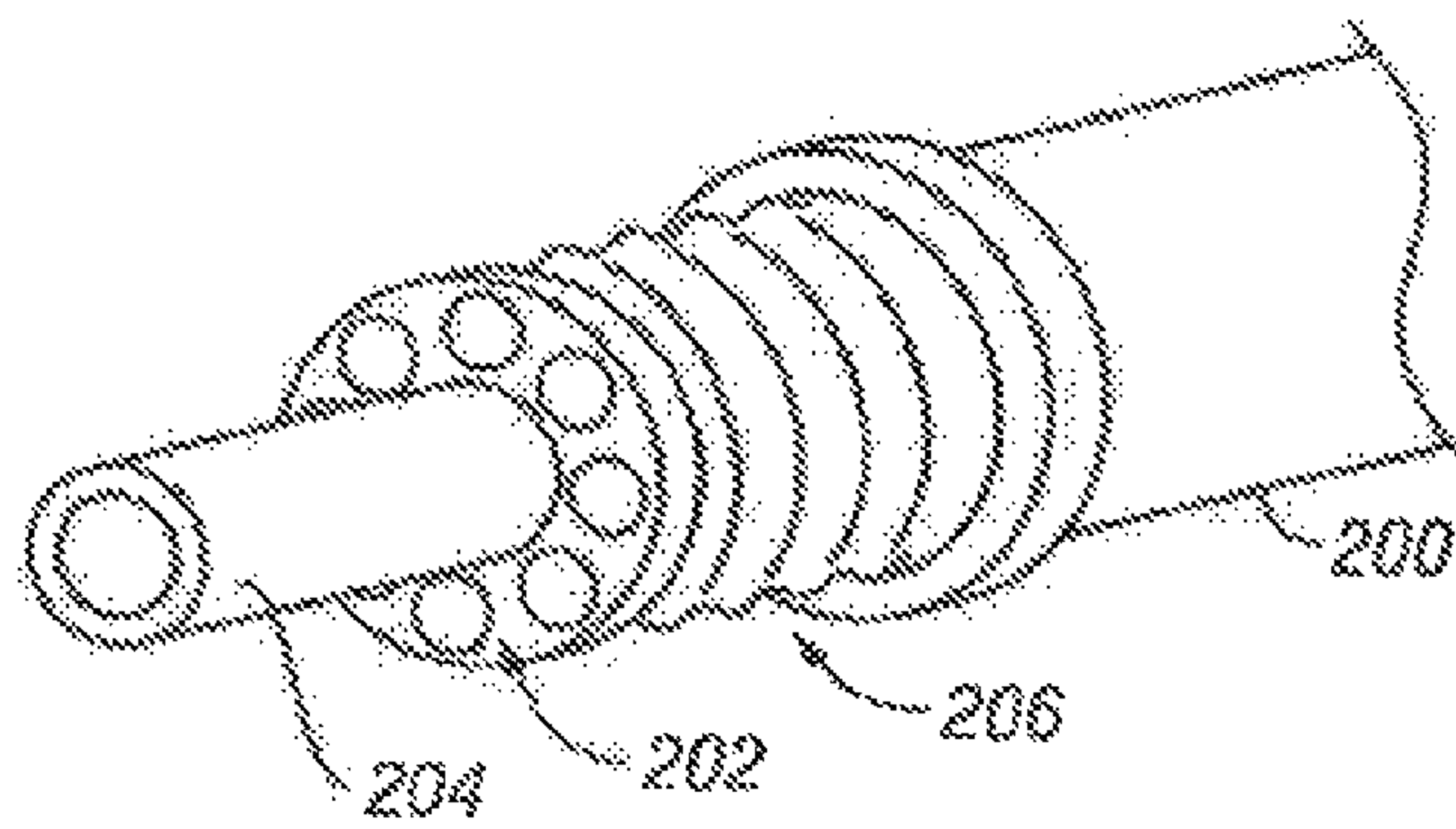

FIG. 10B

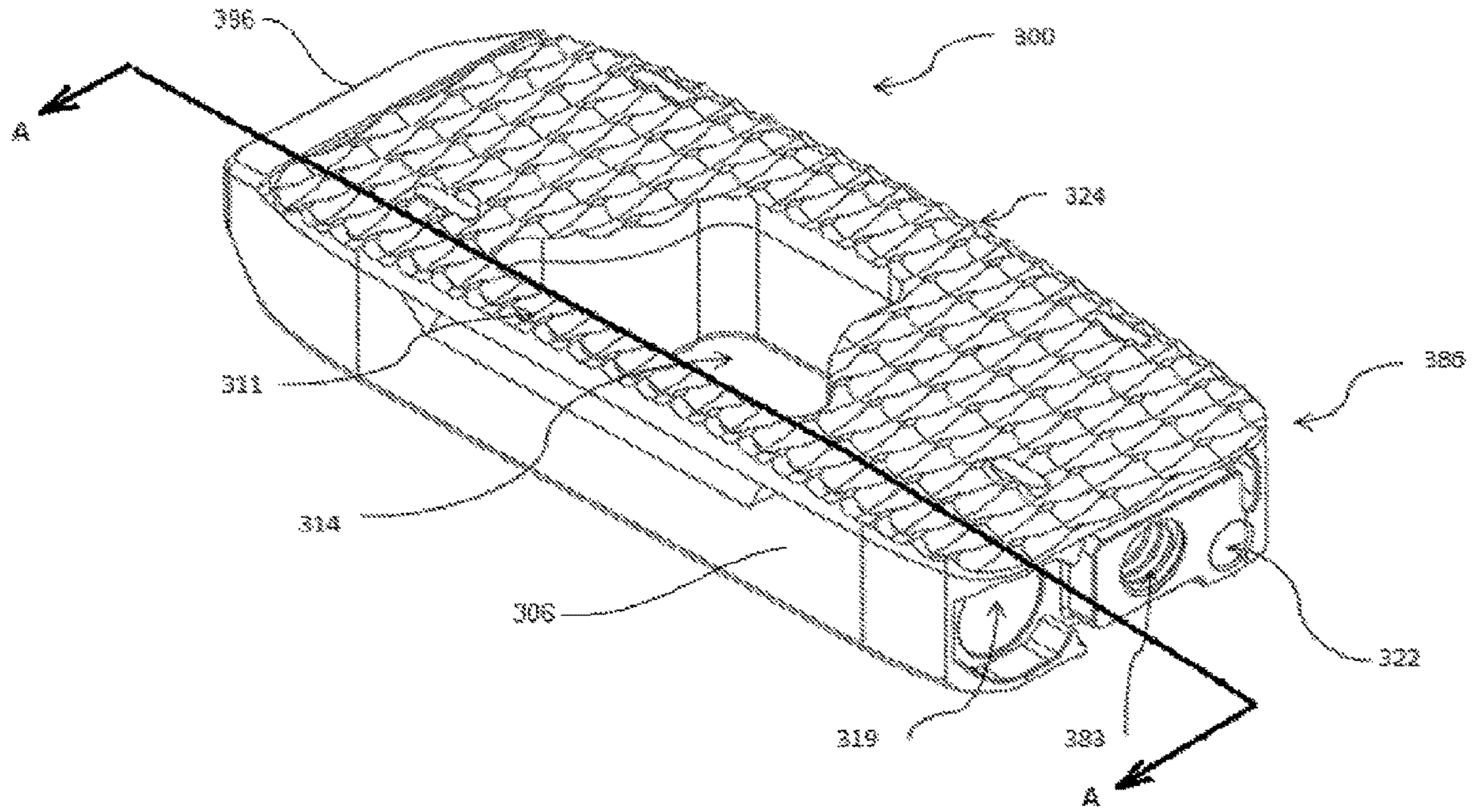

FIG. 11

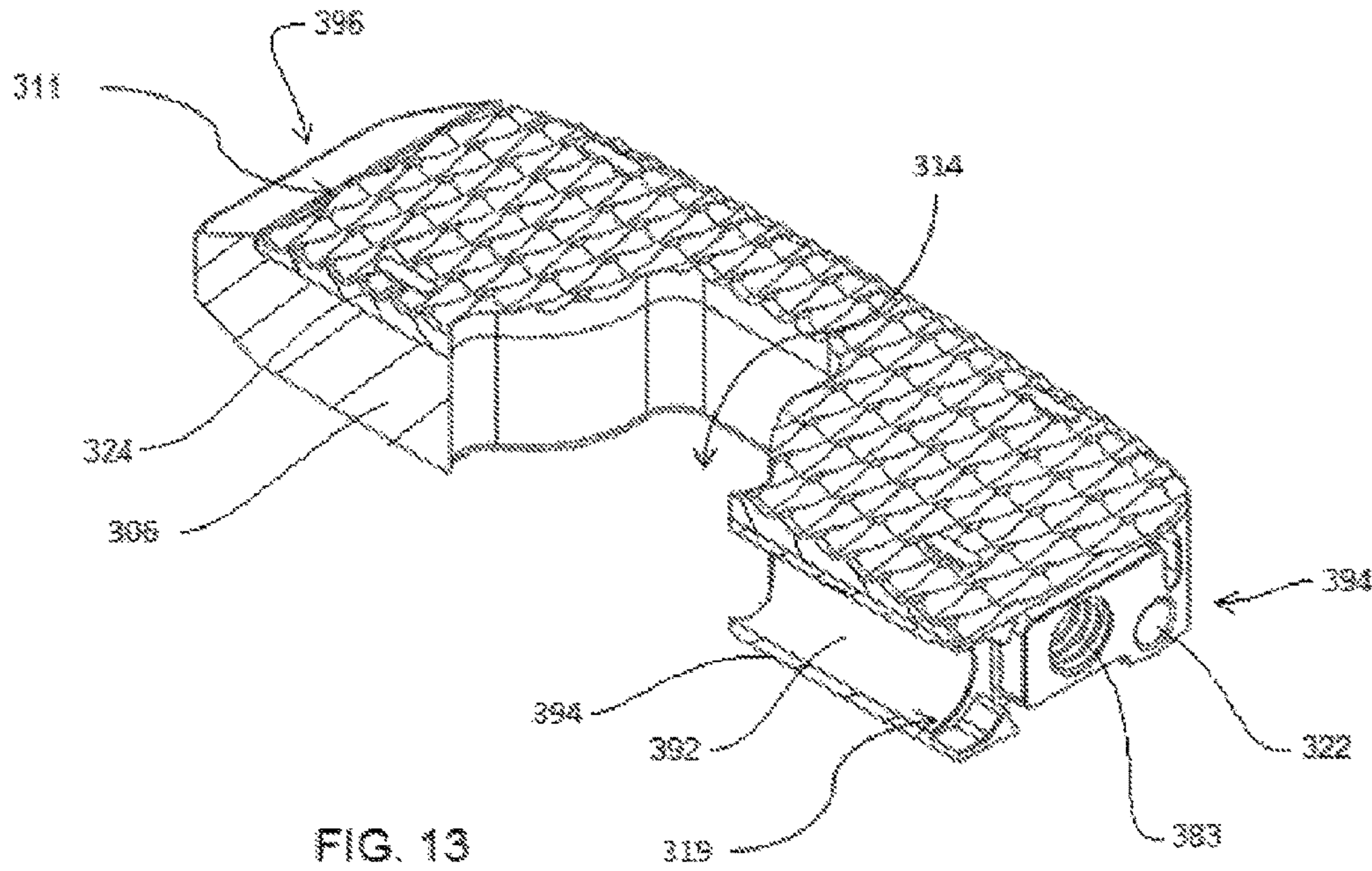

FIG. 13

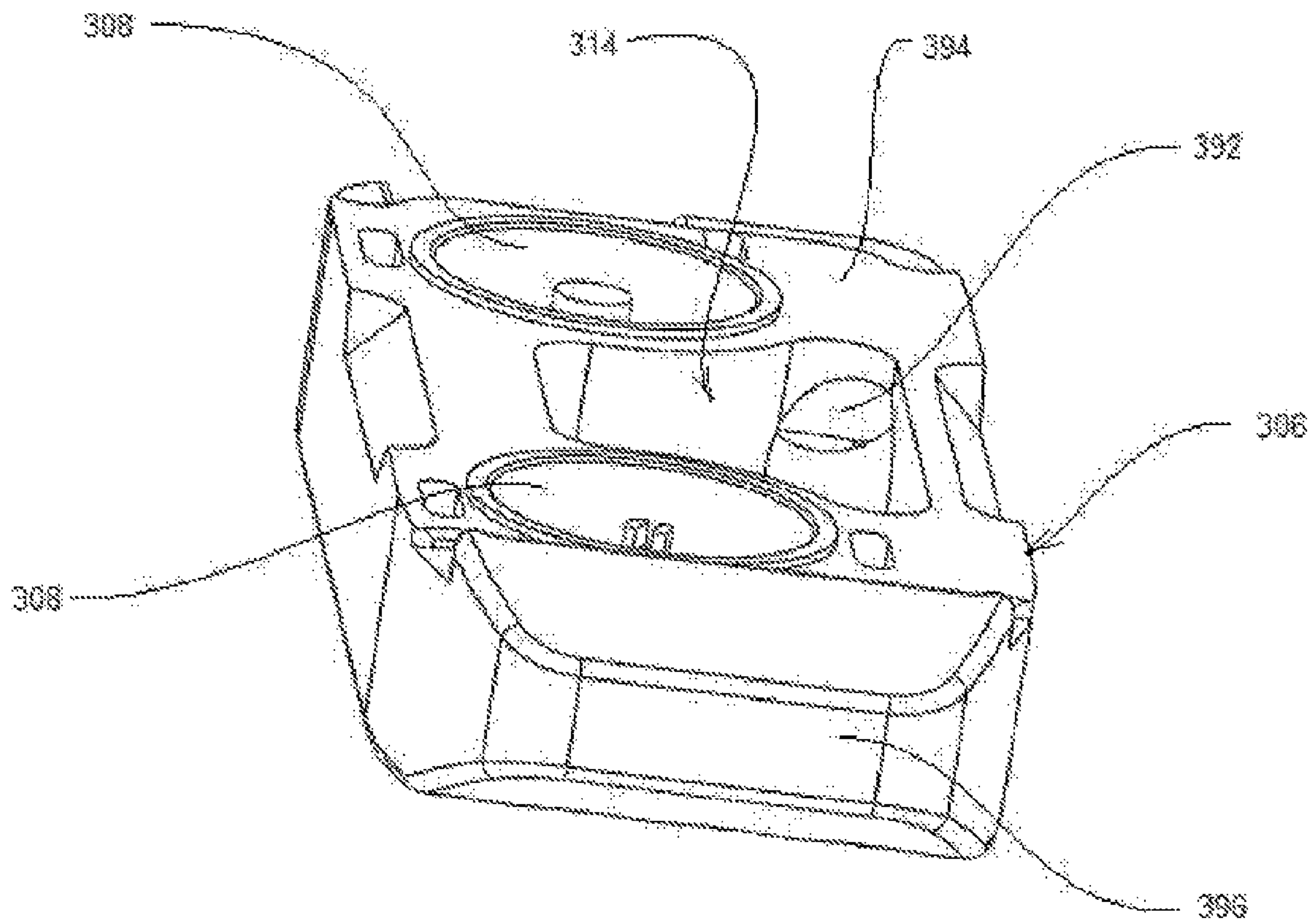
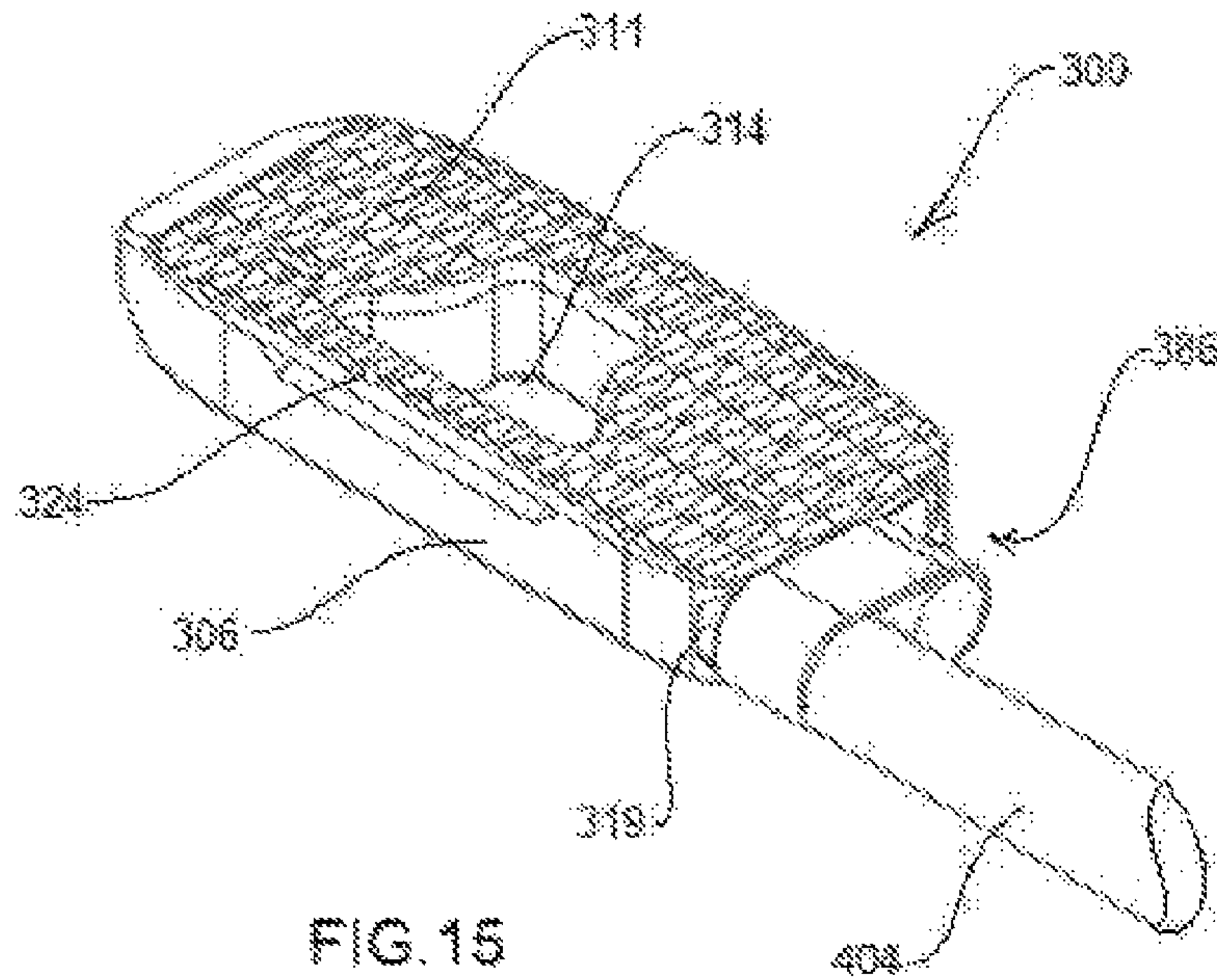
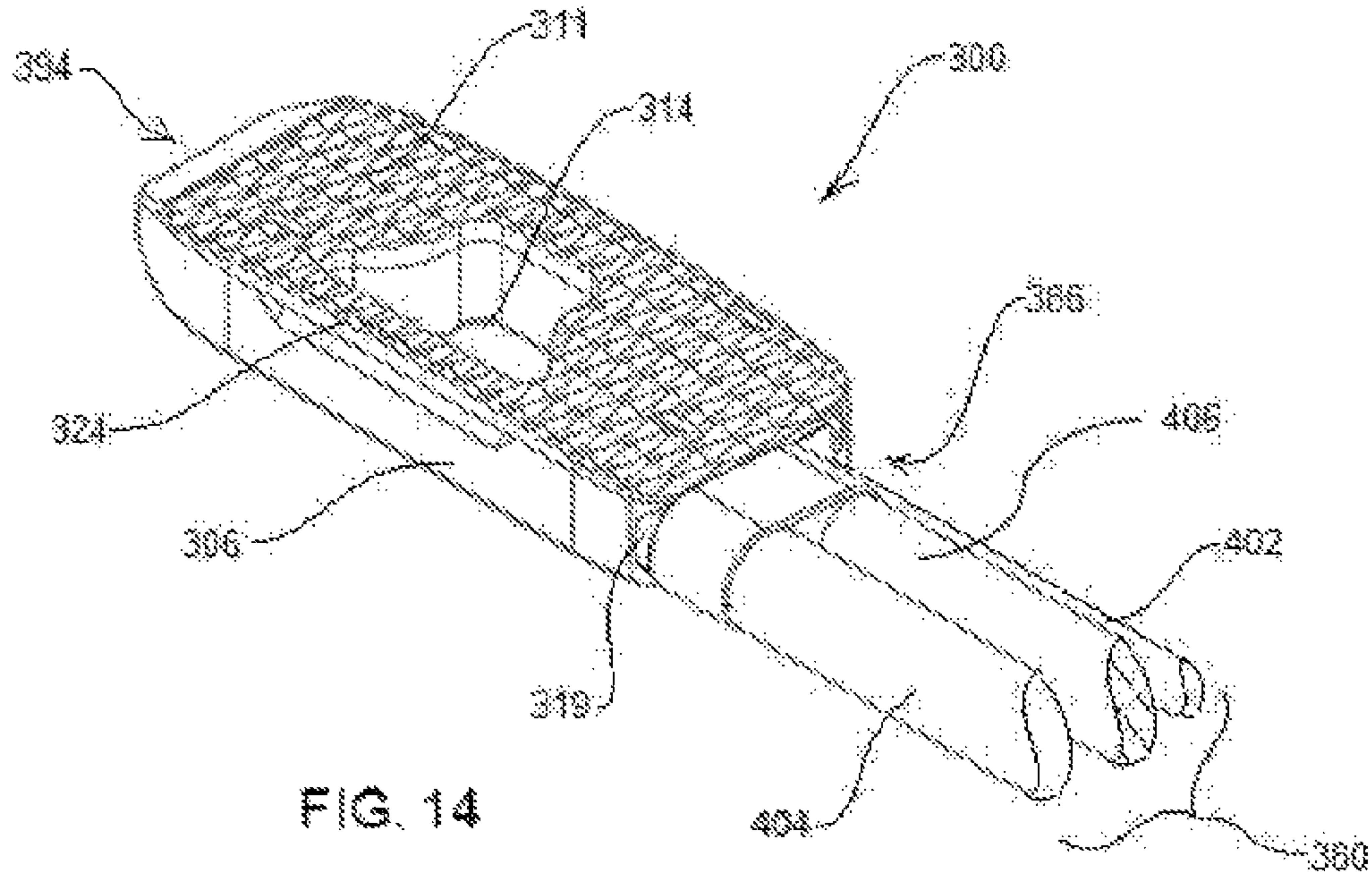

FIG. 12



SELECTIVELY EXPANDING SPINE CAGE WITH ENHANCED BONE GRAFT INFUSION

CROSS REFERENCE TO RELATED APPLICATIONS

This application is a continuation of U.S. patent application Ser. No. 14/689,634, filed on Apr. 17, 2015, which is a continuation of U.S. patent application Ser. No. 13/799,047, filed on Mar. 13, 2013, which is a continuation-in-part of U.S. patent application Ser. No. 13/183,080, filed on Jul. 14, 2011, which is a continuation of U.S. patent application Ser. No. 11/535,432, filed on Sep. 26, 2006, which claims priority from U.S. Provisional Application No. 60/720,784, filed on Sep. 26, 2005, the disclosures of which are hereby incorporated herein by reference.

FIELD OF THE INVENTION

The present invention generally relates to medical devices for stabilizing the vertebral motion segment. More particularly, the field of the invention relates to a remotely activated, hydraulically controllable, selectively expanding cage (SEC) and method of insertion for providing controlled spinal correction in three dimensions for improved spinal intervertebral body distraction and fusion.

BACKGROUND

Conventional spine cages or implants are typically characterized by a kidney bean-shaped body comprising a hydroxyapatite-coated surface provided on the exterior surface for contact with adjacent vertebral segments or endplates which are shown in FIG. 1. A conventional spine cage is typically inserted in tandem posteriorly through the neuroforamen of the distracted spine after a trial implant creates a pathway.

Such existing devices for interbody stabilization have important and significant limitations. These limitations include an inability to expand and distract the endplates. Current devices for interbody stabilization include static spacers composed of titanium, PEEK, and high performance thermoplastic polymer produced by VICTREX, (VICTREX USA Inc, 3A Caledon Court, Greenville, S.C. 29615), carbon fiber, or resorbable polymers. Current interbody spacers do not maintain interbody lordosis and can contribute to the formation of a straight or even kyphotic segment and the clinical problem of "flatback syndrome." Separation of the endplates increases space available for the neural elements, specifically the neural foramen. Existing static cages do not reliably improve space for the neural elements. Therefore, what is needed is an expanding cage that will increase space for the neural elements posteriorly between the vertebral bodies, or at least maintain the natural bone contours to avoid neuropraxia (nerve stretch) or encroachment.

Another problem with conventional devices of interbody stabilization includes poor interface between bone and biomaterial. Conventional static interbody spacers form a weak interface between bone and biomaterial. Although the surface of such implants is typically provided with a series of ridges or coated with hydroxyapatite, the ridges may be in parallel with applied horizontal vectors or side-to-side motion. That is, the ridges or coatings offer little resistance to movement applied to either side of the endplates. Thus, nonunion is common in allograft, titanium and polymer

spacers, due to motion between the implant and host bone. Conventional devices typically do not expand between adjacent vertebrae.

Therefore, what is needed is a way to expand an implant to develop immediate fixation forces that can exceed the ultimate strength at healing. Such an expandable implant ideally will maximize stability of the interface and enhance stable fixation. The immediate fixation of such an expandable interbody implant advantageously will provide stability that is similar to that achieved at the time of healing. Such an implant would have valuable implications in enhancing early post-operative rehabilitation for the patient.

Another problem of conventional interbody spacers is their large diameter requiring wide exposure. Existing devices used for interbody spacers include structural allograft, threaded cages, cylindrical cages, and boomerang-shaped cages. Conventional devices have significant limitation with regard to safety and efficacy. Regarding safety of the interbody spacers, injury to neural elements may occur with placement from an anterior or posterior approach. A conventional spine cage lacks the ability to expand, diminishing its fixation capabilities.

The risks to neural elements are primarily due to the disparity between the large size of the cage required to adequately support the interbody space, and the small space available for insertion of the device, especially when placed from a posterior or transforaminal approach. Existing boomerang cages are shaped like a partially flattened kidney bean. Their implantation requires a wide exposure and potential compromise of vascular and neural structures, both because of their inability to enter small and become larger, and due to the fact that their insertion requires mechanical manipulation during insertion and expanding of the implant. Once current boomerang implants are prepared for insertion via a trial spacer to make a pathway toward the anterior spinal column, the existing static cage is shoved toward the end point with the hope that it will reach a desired anatomic destination. Given the proximity of nerve roots and vascular structures to the insertion site, and the solid, relatively large size of conventional devices, such constraints predispose a patient to foraminal (nerve passage site) encroachment, and possible neural and vascular injury.

Therefore, what is needed is a minimally invasive expanding spine cage that is capable of insertion with minimal invasion into a smaller aperture. Such a minimally invasive spine cage advantageously could be expanded with completely positional control or adjustment in three dimensions by hydraulic force application through a connected thin, pliable hydraulic line. The thin hydraulic line would take the place of rigid insertional tools, thereby completely preventing trauma to delicate nerve endings and nerve roots about the spinal column. Due to the significant mechanical leverage developed by a hydraulic control system, the same expanding cage could advantageously be inserted by a minimally-sized insertion guiding rod tool capable of directing the cage through the transforaminal approach to a predetermined destination, also with reduced risk of trauma to nerve roots. That is, the mechanical advantage is provided by a hydraulic control system controlled by the physician external to the patient.

The minimally-sized insertion tool could house multiple hydraulic lines for precise insertion and expansion of the cage, and simply detached from the expanded cage after insertion. It is noted that in such a hydraulic system, a smaller, thinner line advantageously also increases the pounds per inch of adjusting force necessary to achieve proper expansion of the implant (as opposed to a manually

3

powered or manipulated surgical tool) that must apply force directly at the intervention site. That is, for a true minimally-invasive approach to spinal implant surgery what is needed is an apparatus and method for providing the significant amount of force necessary to properly expand and adjust the cage against the vertebral endplates, safely away from the intervention site.

What is also needed is a smaller expanding spine cage that is easier to operatively insert into a patient with minimal surgical trauma in contrast to conventional, relatively large devices that create the needless trauma to nerve roots in the confined space of the vertebral region.

Existing interbody implants have limited space available for bone graft. Adequate bone graft or bone graft substitute is critical for a solid interbody arthrodesis. It would be desirable to provide an expandable interbody cage that will permit a large volume of bone graft material to be placed within the cage and around it, to fill the intervertebral space. Additionally, conventional interbody implants lack the ability to stabilize endplates completely and prevent them from moving. Therefore, what is also needed is an expanding spine cage wherein the vertebral end plates are subject to forces that both distract them apart, and hold them from moving. Such an interbody cage would be capable of stabilization of the motion segment, thereby reducing micro-motion, and discouraging the pseudoarthrosis (incomplete fusion) and pain.

Ideally, what is needed is a spine cage or implant that is capable of increasing its expansion in width anteriorly to open like a clam, spreading to a calculated degree. Furthermore, what is needed is a spine cage that can adjust the amount of not only overall anterior expansion, but also medial and lateral variable expansion so that both the normal lordotic curve is maintained, and adjustments can be made for scoliosis or bone defects. Such a spine cage or implant would permit restoration of normal spinal alignment after surgery and hold the spine segments together rigidly, mechanically, until healing occurs.

What is also needed is an expanding cage or implant that is capable of holding the vertebral or joint sections with increased pullout strength to minimize the chance of implant fixation loss during the period when the implant is becoming incorporated into the arthrodesis bone block.

It would also be desirable if such a cage could expand anteriorly away from the neural structures and along the axis of the anterior spinal column, rather than uniformly which would take up more space inside the vertebral body surfaces.

SUMMARY OF THE DISCLOSURE

In one implementation, the present disclosure is directed to a selectively expandable spinal implant for insertion between vertebrae of a patient. The selectively expandable spinal implant comprises a cylinder block defining at least first and second cylinders and comprising a base configured for resting on a first vertebrae; at least first and second pistons respectively received in the at least first and second cylinders, the pistons being extendable to impart a desired spinal correction; and a bone engaging plate attached to the pistons opposite the base for engaging a second vertebrae in response to extension of the pistons.

In another implementation, the present disclosure is directed to an apparatus for providing spinal correction. The apparatus includes an implant body configured and dimensioned for placement in an intervertebral space, the body defining a central cavity extending through the body configured to receive bone graft material and communicate with

4

the intervertebral space for infusion of the graft material into the intervertebral space when placed therein, and a bone graft supply passage extending through the body and communicating with the central cavity; a bone graft material supply port disposed on the implant body in communication with the bone graft supply passage, the port configured for attachment of a bone graft material supply line; first and second extendable members mounted on the body, one each disposed on an opposite side of the central cavity, the members extendable from a first unexpanded height and to at least one expanded height; and a plate with a bone engaging surface mounted on the first and second extendable members, the plate defining an opening aligned with the central cavity for passage there through of bone graft material from the central cavity.

In yet another implementation, the present disclosure is directed to an apparatus for providing spinal correction. The apparatus includes an implant body configured and dimensioned for placement in an intervertebral space with a surface configured as a bone engaging surface, the body configured as a cylinder block defining first and second cylinders opening opposite the bone engaging surface and communicating with at least one hydraulic fluid passage, a central, bone graft material receiving cavity extending through the body, and a bone graft supply passage communicating with the central cavity, wherein the central cavity is configured to open to intervertebral space for infusion of the graft material into the intervertebral space when placed therein; first and second extendable pistons sealingly received in the cylinders; a top plate with an opposed bone engaging surface mounted on the first and second pistons, the top plate extendable with the pistons from a first unexpanded implant height and to at least one expanded implant height, the top plate defining an opening aligned with the central cavity for passage there through of bone graft material from the central cavity; a bone graft material supply port disposed on the implant body in communication with the bone graft supply passage, the port configured for attachment of a bone graft material supply line; a hydraulic supply port disposed on the implant body adjacent the bone graft material supply port, the hydraulic supply port communicating with the at least one hydraulic fluid passage; and an attachment port disposed on the implant body adjacent the supply port, the attachment port being configured to receive and secure an implant insertion tool.

BRIEF DESCRIPTION OF THE DRAWINGS

For the purpose of illustrating the invention, the drawings show aspects of one or more embodiments of the invention. However, it should be understood that the present invention is not limited to the precise arrangements and instrumentalities shown in the drawings, wherein:

FIG. 1 is a representation of the vertebral column showing posterior insertion and placement of the SEC between the number 4 and 5 lumbar vertebrae according to an aspect of the invention. Whereas this diagram shows the implant anteriorly in the vertebral interspace between lumbar bones 4 and 5, the majority of lumbar fusions are performed between L5 and S1, into which implants are secured. The SEC can be used at any spinal level the surgeon deems in need of fusion;

FIG. 2 is a side view of a vertebral body showing the placement of the SEC according to an aspect of the invention;

FIG. 3 is a top view of a vertebral body showing placement of the SEC according to an aspect of the invention;

FIG. 4A is a front perspective view of the SEC in an unexpanded state according to an aspect of the invention;

FIG. 4B is a rear perspective view of the SEC of FIG. 4A according to an aspect of the invention;

FIG. 4C is a rear perspective view of the SEC of FIG. 4A showing details of the hydraulic and bone graft input ports according to an aspect of the invention;

FIG. 4D is a perspective view of the SEC of FIG. 4A with the wedge plate removed for clarity;

FIG. 4E is a perspective view of FIG. 4A showing the cylinders and bone graft perfusing cavity defined by the SEC body according to an aspect of the invention;

FIG. 4F shows another view of the wedge plate according to an aspect of the invention;

FIG. 4G shows details of the wedge plate and lordosis plate according to an aspect of the invention;

FIG. 5A is a front perspective view of the SEC in an expanded state according to an aspect of the invention;

FIG. 5B is a top perspective view of the SEC showing the cavity for bone graft perfusion and recesses allowing lateral movement of the wedge according to an aspect of the invention;

FIG. 5C is a rear perspective view of the SEC in an expanded state according to an aspect of the invention;

FIG. 5D is a perspective view of FIG. 5C with the SEC body removed for clarity;

FIG. 6 is a perspective view of an alternative embodiment of the SEC according to an aspect of the invention;

FIG. 7A is a perspective view of a master cylinder for hydraulic control of the SEC according to an aspect of the invention. A variety of alternative embodiments are available, most simply disposable syringes used for piston expansion;

FIG. 7B is a view of the interior of FIG. 7A;

FIG. 8 is a perspective view of an alternate embodiment of the master cylinder according to an aspect of the invention;

FIG. 9A is a perspective view of the insertion tool holding the SEC, hydraulic lines and bone graft supply line according to an aspect of the invention;

FIG. 9B is a close-up view of the insertion tool of FIG. 9A;

FIG. 10A shows one embodiment of a hydraulic line for independent control of multiple slave cylinders according to an aspect of the invention; and

FIG. 10B shows a close up of the fitting for the hydraulic line of FIG. 10A according to an aspect of the invention.

FIG. 11 is a perspective view of a further alternative embodiment of an SEC according to another aspect of the invention.

FIG. 12 is a perspective distal view of the exemplary embodiment shown in FIG. 11, with the top plate and pistons removed.

FIG. 13 shows a cross-section through line A-A in FIG. 11.

FIG. 14 is a perspective view of the exemplary embodiment shown in FIG. 11 with an attached insertion tool.

FIG. 15 is a perspective view of the exemplary embodiment shown in FIG. 11 with an attached bone graft material supply line.

DETAILED DESCRIPTION

Referring to FIG. 1, vertebral segments or end plates are shown with an average 8 mm gap representing an average intervertebral space. A complete discectomy is performed prior to the insertion of the SEC 100. The intervertebral disc

occupying space 102 is removed using standard techniques including rongeur, curettage, and endplate preparation to bleeding subcondral bone. The posterior longitudinal ligament is divided to permit expansion of the intervertebral space.

The intervertebral space 102 is distracted to about 10 mm using a rotating spatula (Not shown. This is a well-known device that looks like a wide screw driver that can be placed into the disc space horizontally and turned 90 degrees to separate the endplates).

The SEC is inserted posteriorly (in the direction of arrow 102 between the no. 4 and 5 lumbar vertebrae as shown in FIG. 1 (lateral view) or into any selected intervertebral space. In accordance with an aspect of the invention, the SEC is reduced to small size in its unexpanded state to enable it to be inserted posteriorly through space 102 as shown in FIG. 1. In one exemplary embodiment, dimensions of an SEC are: 12 mm wide, 10 mm high and 28 mm long to facilitate posterior insertion and thereby minimize trauma to the patient and risk of injury to nerve roots. Once in place this exemplary SEC can expand to 16 mm, or 160 percent of its unexpanded size, enabling 20 degrees or more of spinal correction medial and lateral. FIGS. 2 and 3 are a side view and top view, respectively, showing the placement of the SEC 100 on a vertebral body.

FIG. 4A shows SEC 100 from the front or anterior position with respect to the vertebral column. The SEC is shown in a closed or unexpanded position. Referring to FIGS. 4A through 4E, SEC 100 comprises a body or block 106 that defines one or more slave cylinders 108a, 108b (best seen in FIG. 5A) for corresponding pistons 110a, 110b. Pistons are provided with O-rings 112a, 112b for a tight seal with the cylinder. The pistons and cylinders cooperate to provide hydraulically extendable members disposed within the body of SEC 100 in the unexpanded state. Block 106 also defines a central cavity 114 for infusion of bone graft material into the intervertebral space when the SEC is fully expanded or during the expansion process, as will be explained.

In general, bone graft material can be any substance that facilitates bone growth and/or healing (whether naturally occurring or synthetic), such as, for example, osteoconduction (guiding the reparative growth of the natural bone), osteoinduction (encouraging undifferentiated cells to become active osteoblasts), and osteogenesis (living bone cells in the graft material contribute to bone remodeling). Osteogenesis typically only occurs with autografts.

As shown in FIG. 4C, block 106 further defines a central or main input port 116 for attachment of hydraulic lines and a line for transmission of a slurry or liquid bone graft material as will be explained. The block 106 defines a bone graft infusion conduit that extends from a bone graft input port 119 located in main input port 116 to a bone graft exit port 120 (see FIG. 4D) located in central cavity 114 for infusion of bone graft material therein.

Block 106 further defines local hydraulic fluid input ports 122a, 122b (FIG. 4C) that lead to corresponding slave cylinders 108a, 108b (FIG. 5A) for driving the pistons and expanding the SEC by remote control from a master cylinder located ex vivo and with greatly increased force as compared to conventional devices.

It will be appreciated that each slave piston 110a, 110b is independently controlled by a separate hydraulic line 122a, 122b connected to a master cylinder (as will be explained with reference to FIGS. 7a through 8) located away from the patient and the site of implantation, thus minimizing active intervention by surgical tools in the immediate vicinity of

nerve roots. Although two slave cylinders are shown by way of example, it will be appreciated that the invention is not so limited, but on the contrary, SEC block **106** easily is modifiable to define a multiplicity of slave cylinders, each controlled independently by a separate hydraulic line, for expanding differentially to provide a substantially infinite variety of space-sensitive adjustments for unique applications.

Referring again to FIGS. **4A** through **4G**, an anterior/posterior corrective plate or wedge plate **124** is movably held in captured engagement on top of pistons **110a**, **110b** by corresponding hold down screws **126a**, and **126b**. Plate **124** enables spinal correction in the anterior/posterior direction as the cylinders expand vertically. Plate **124** has a bone-engaging top surface provided with two elongated slots **128a**, **128b** in which the hold down screws sit. The elongated slots **128a**, **128b** enable ease of expansion and facilitate angles between the pistons by allowing the plate **124** to move laterally slightly as pistons differentially expand. The plate also defines cavity **114** for the infusion of bone graft material, that is co-extensive with and the same as cavity **114** defined by the SEC block. This enables perfusion of the bone graft material directly through the bone engaging surface of the wedge plate into the adjacent vertebral body.

Referring to FIGS. **4F** and **4G**, the anterior/posterior corrective plate **124** is provided with a downwardly-extending edge **130** for engagement with the pistons as they differentially expand, to ensure that wedge plate stays firmly in place. Plate **124** provides anterior/posterior correction in that it can be angled front to back like a wedge with a correction angle α of 0-5 degrees or more. Plate **124** also defines bone graft cavity **114** for enabling bone growth conductive or inductive agents to communicate directly with the engaged vertebral endplate.

The SEC is optionally provided with a lordosis base plate **132** that includes a bone engaging surface defining a cavity co-extensive with bone graft cavity **114** for enabling perfusion of bone graft material into the adjacent engaged vertebral body. Lordosis base plate **132** also has an anterior/posterior angle β (refer to FIG. **4G**) of 0-5 degrees for correcting lordosis.

Referring to FIG. **4G**, top plate **124** and optional lordosis base plate **132** function as two endplates providing a corrective surface that impacts vertebral bodies for spinal correction. Top plate **124** and lordosis base plate **132** each include a bone-engaging surface **125** and **133**, respectively, defining a cavity co-extensive with bone graft cavity **114** for enabling perfusion of bone graft material into the adjacent opposed vertebral body. Lordosis base plate also has anterior/posterior angle β of 0-5 degrees for correcting lordosis. Thus, the wedge plate and lordosis base plate can provide lordotic correction of 10 degrees or more.

Surgeon control over sagittal alignment is provided by differential wedge shaping of the endplates and by calculated degrees of variable piston expansion. The end plates will be constructed with 0 degrees of wedge angle anterior to posterior, or 5 degrees. Therefore, the final construct may have parallel end plates (two 0 degree endplates), 5 degrees of lordosis (one 5 degree and one 0 degree endplate), or 10 degrees of lordosis (two 5 degree implants). This implant permits unprecedented flexibility in controlling spinal alignment in the coronal and sagittal planes.

Since vertebral end plates are held together at one end by a ligament much like a clamshell, expansion of the pistons vertically against the end plates can be adjusted to create the desired anterior/posterior correction angle. Thus, the top plate **124** does not need to be configured as a wedge. Where

an extreme anterior/posterior correction angle is desired, the top plate and/or base plate may be angled as a wedge with the corresponding correction angles set forth above.

FIGS. **5A** through **5D** show the SEC in its expanded state. Hydraulic fluid flows from a master cylinder (FIG. **7A**) into the cylinders through separate hydraulic input lines that attach to hydraulic input ports **122a**, **122b**. Each hydraulic line is regulated independently thereby allowing a different quantity of material to fill each cylinder and piston cavity pushing the pistons and medial/lateral wedge plate upward to a desired height for effecting spinal correction.

In accordance with an aspect of the invention, the hydraulic fluid communicating the mechanical leverage from the master cylinder to the slave cylinder or syringe and pistons advantageously is a time-controlled curable polymer such as methyl methacrylate. The viscosity and curing time can be adjusted by the formulation of an appropriate added catalyst as is well known. Such catalysts are available from LOCTITE Corp., 1001 Trout Brook Crossing, Rocky Hill, Conn. 06067. When the polymer cures, it hardens and locks the pistons and thus the desired amount of spinal correction determined by the physician is immovably in place.

It will be appreciated that the cylinder block **106** and pistons **110a**, **110b**, comprise a biocompatible, substantially incompressible material such as titanium, and preferably type 6-4 titanium alloy. Cylinder block **106** and pistons **110a**, **110b** completely confine the curable polymer that is acting as the hydraulic fluid for elevating the pistons. When the desired spinal correction is achieved by the expanded pistons, the curable polymer solidifies, locking the proper spinal alignment substantially invariantly in place. The confinement of the polymer by the titanium pistons and cylinder block provides the advantage of making the polymer and the desired amount of spinal alignment substantially impervious to shear and compressive forces.

For example, even if it were possible to compress the polymer it could only be compressed to the structural limit of the confining cylinder block. That is, by placing the curable polymer into the 6-4 titanium cylinder block wherein two or more cylinders are expanded, the polymer becomes essentially non-compressible especially in a lateral direction. It will be appreciated that 6-4 titanium cylinder block confining the hydraulic material provides extreme stability and resistance to lateral forces as compared to a conventional expanding implant. Further, there is no deterioration of the curable polymer over time in term of its structural integrity because it is confined in the titanium alloy body.

The use of the present 6-4 titanium cylinder block configuration can withstand compressive forces in excess of 12,000 Newtons or approximately 3000 pounds of compressive force on the vertebrae. This is not possible in a conventional expanding structure wherein the expanding polymer is not confined by an essentially incompressible titanium body.

In accordance with another aspect of the invention, injectable bone graft material **134** is provided along a separate bone graft input line to bone graft input port **119** for infusion into cavity **114** through bone graft exit port **120**.

The bone graft input line is controlled at the master cylinder or from a separate source to enable a pressure-induced infusion of bone graft material **134** through cavity of the bone engaging surfaces of the SEC into adjacent vertebral bone. Thus, the bone graft material fills, under pressure, the post-expansion space between adjacent vertebral bodies. This achieves substantially complete perfusion of osteo-inductive and/or osteo-conductive bone graft mate-

rial in the post expansion space between the vertebral bodies resulting in enhanced fusion (refer to FIGS. 5C, 5D).

Referring to FIG. 6, an alternate embodiment of the SEC comprises multiple slave cylinders and corresponding pistons **110a**, **110b**, **110n** are provided in SEC body **106**. Each of the multiple slave cylinders and pistons **110a**, **110b**, **110n** is provided with a separate, associated hydraulic line **122a**, **122b**, **122n** that communicates independently with a corresponding one of a plurality of cylinders in the master cylinder for independently controlled expansion of the slave cylinders at multiple elevations in three dimensions (X, Y and Z axes).

At the master cylinder, multiple threaded cylinders (or disposable syringes) and pistons are provided, each communicating independently through a separate hydraulic line **122a**, **122b**, **122n** with a corresponding one of the slave cylinders and pistons **110a**, **110b**, **110n** in the SEC.

The bone engaging surfaces of the multiple pistons **110a**, **110b**, **110n** provide the corrective surface of the SEC. Thus, by appropriate adjustment of the pistons in the master cylinder, or depending on fluid installed via separate syringes, the surgeon can independently control expansion of the slave pistons in the SEC to achieve multiple elevations in three dimensions for specialized corrective applications. A top or wedge plate is not necessary.

The bone engaging surface **111** of the slave pistons **110a**, **110b**, **110n** in the SEC may be provided with a specialized coating for bone ingrowth such as hydroxyapatite. Alternatively, the bone-engaging surface **111** of the SEC pistons may be corrugated, or otherwise provided with a series of bone engaging projections or cavities to enhance fusion.

As previously explained, the hydraulic fluid communicating the mechanical leverage from the master cylinder to the SEC slave cylinders and pistons **110a**, **110b**, **110n** is a time-controlled curable polymer such as methyl methacrylate that locks the SEC immovably in place after curing, at the desired three dimensional expansion.

As set forth above, injectable bone graft material is provided along a separate bone graft input line to bone graft input port **119** for infusion into cavity **114** and into the inter body space between the SEC and adjacent bone.

The surgeon by adjustment of the master cylinder is able to provide remotely a controlled angle of the SEC corrective surface to the medial/lateral (X axis) and in the anterior, posterior direction (Z axis). The surgeon also can adjust the SEC in the vertical plane moving superiorly/inferiorly (Y axis) from the master cylinder or power/flow source to control implant height. Thus, three-dimensional control is achieved remotely through a hydraulic line with minimal trauma to a patient. This aspect of the invention advantageously obviates the need to manually manipulate the SEC implant at the site of intervention to achieve desired angles of expansion. Such conventional manual manipulation with surgical tools into the intervention site can require further distracting of nerve roots and cause potential serious trauma to a patient.

Referring to FIGS. 7A and 7B, in accordance with an aspect of the invention, a master cylinder **140** located remotely from the patient, provides controlled manipulation and adjustment of the SEC in three dimensions through independent hydraulic control of slave cylinders **110a**, **110b** in the SEC. Master cylinder **140** comprises a cylinder block **142**, defining two or more threaded cylinders **143**. Corresponding screw down threaded pistons are rotated downward into the threaded cylinders thereby applying force to a hydraulic fluid in corresponding hydraulic control lines that communicate independently with and activate correspond-

ing slave cylinders **110a**, **110b** in the SEC with mechanical leverage. The rotational force for applying the mechanical leverage at the slave cylinders is controlled by thread pitch of the threaded pistons in the master cylinder, or in an alternate embodiment controlled by use of syringes, one acting as a master cylinder for each piston or slave cylinder to modulate piston elevation.

In FIG. 7B threaded pistons **144a**, **144b** are provided in hydraulic cylinders communicating through hydraulic lines **148a**, **148b** that are coupled to hydraulic input ports **116a**, **116b** for independent hydraulic control of slave cylinders **110a**, **110b** as previously explained.

Another threaded cylinder and piston assembly **150** is supplied with a quantity of bone graft material in slurry or liquid form and operates in the same way to provide the bone graft material under pressure to the SEC bone graft input port **119** through bone graft supply line **152**. Thus, bone graft material is forced under pressure from the master cylinder through cavity **114** and into the intervertebral space.

Referring to FIG. 8, an alternate embodiment of a master cylinder is provided for individual hydraulic control of each slave piston in the SEC implant. A master cylinder **154** is provided with two or more cylinders **156a**, **156b**, and associated pistons **157a**, **157b**. A lever **158** controlled by the surgeon is attached to each piston. Hydraulic fluid feeds through lines **148a** **148b** into the inserted SEC implant. The lever creates a ratio of 1 pound to 10 pounds of pressure inside the slave cylinders in the SEC and thus against vertebral end plates. Mechanically this provides a 10:1 advantage in lift force for the surgeon. The surgeon's required force application is multiplied via the lever and hydraulic system to create a controlled expansion of the SEC against the end plates as previously described to create any desired spine vertebral correctional effect in three dimensions.

If the surgeon uses one pound of force on the lever, the piston exerts 10 pounds of force. The piston in the master cylinder displaces the hydraulic fluid through hydraulic lines **148a**, **148b**. The hydraulic lines are flexible conduit no more than 3 mm in diameter. Thin hydraulic lines are desirable to increase mechanical advantage at the slave cylinders in the SEC. If one pound of pressure is exerted on the handle, the corresponding piston in the SEC would have 10 pounds of lifting force. If each slave piston inside the SEC implant has 200 pounds of lifting force, the required amount of pressure applied by the surgeon to the master piston cylinder is 20 pounds, or one tenth the amount, consistent with the predetermined mechanical advantage.

In usual cases, where the surgeon has a patient in a partially distracted anatomic, anesthetized and relaxed position under anesthesia, 30 pounds of force may be required for implant expansion upon the vertebral bone endplates. The surgeon in that case would need to apply only 3 pounds of pressure to lever **158**. Different ratios may be introduced to optimize distraction force while minimizing injection pressures.

The pressure application process is guided by normal surgical principles, by visual checkpoints, and by a safety gauge that illustrates the amount of expansion that has been exerted in direct correlation with the implant expansion process. The gauge indicates the height of the slave pistons and thus the vertical and angular expansion of the SEC. This translates to an ability to clarify the percentage of lateral expansion. That is, if the surgeon chooses to create an angle, he expands the right slave cylinder, for example, 14 mm and left slave cylinder 12 mm.

The master cylinder **154** preferably comprises transparent plastic to enable visual indication of the height of the hydraulic fluid therein, or a translucent plastic syringe to facilitate exact measured infusion of the slave cylinder implant expanding pistons. A knob **159** for setting gauge height is provided in each cylinder. An indicator attached to the knob registers the cylinder height with respect to a fill line, bleed line or maximum height line. The master cylinder and slave cylinders are filled with hydraulic fluid. Air is removed by bleeding the cylinders in a well-known manner. The knob indicator is registered to the bleed line. A series of incremental marks are provided between the bleed line and the maximum height line to show the surgeon the exact height of the slave cylinder in response to the surgeon's control inputs to the master cylinder.

It will be appreciated that the master and slave hydraulic system interaction can have many equivalent variations. For example, the master cylinder function of master cylinder **154** also can be provided by one or more syringes. Each syringe acts as a master cylinder and is coupled independently with a corresponding slave cylinder through a thin hydraulic line for independent activation as previously described. A single syringe acting as a master cylinder also may be selectively coupled with one or more slave cylinders for independent activation of the slave cylinders. As is well known, series of gradations are provided along the length of the syringe that are calibrated to enable the surgeon to effect a precise elevation of a selected piston at the corresponding slave cylinder in the implant.

As previously explained, the SEC implant also expands vertically the intervertebral space from 10 mm to 16 mm or more. Additionally, by changing the diameter of the piston inside the master cylinder, the force exerted into the slave cylinder could be multiplied many fold so as to create major force differentials. The foregoing features provide the surgeon with an ability to establish a spinal correction system that is a function of the needed change to correct a deformity, so as to produce normal alignment.

Referring to FIG. **9A**, it will be appreciated that hydraulic control lines **148a** and **148b** and bone graft supply line **152** are characterized by a minimal size and are provided in the interior of a very narrow insertion tool **180** (FIGS. **9A** and **9B**). The insertion tool **180** is small enough to insert the SEC **100** posteriorly into the narrow insertion opening without risk of serious trauma to the patient. An enlarged view of the insertion tool **180** (simplified for clarity) is shown in FIG. **9B**. The insertion tool **180** includes a handle **182** and hollow interior for housing hydraulic control lines and a bone graft supply line (not shown for clarity). The hydraulic control lines and bone graft supply line connect through a proximal end of the insertion tool to the master cylinder. A distal or insertion end of the tool holds the SEC **100**. In a preferred mode, the insertion end of the insertion tool conformably fits in the SEC hydraulic input port **116**. Hydraulic control lines and the bone graft supply line are connected to the hydraulic input ports **122a**, **122b** and bone graft supply input port respectively, prior to surgery.

The bone graft supply and hydraulic control lines are safely retracted after the SEC is positioned. The hydraulic lines can be released by cutting after the operation since the hydraulic fluid hardens in place.

When the SEC is locked in position by the surgeon, the insertion tool and hydraulic tubes are removed and the curable polymer remains in the SEC slave cylinders.

In accordance with an aspect of the invention, the hydraulic fluid controlling the movement of the SEC is a time-controlled curable polymer that hardens after a pre-deter-

mined time period, locking the SEC insert immovably in a desired expanded position. The hydraulic fluid is preferably methylmethacrylate or other similar inexpensive polymer, with a time-controlled curing rate. Time-controlled curable polymers typically comprise a catalyst and a polymer. The catalyst can be formulated in a well-known manner to determine the time at which the polymer solidifies. Such time-controlled curable polymers are commercially available from several manufacturers such as LOCTITE Corp., Henkel-Loctite, 1001 Trout Brook Crossing, Rocky Hill, Conn. 06067.

As is well understood by one skilled in the art, any equivalent curable polymer that has a first flowable state for conveying hydraulic force, and that transitions to a second solid state upon curing may be employed. In the first state, the curable polymer transfers the application of force hydraulically from the master cylinder to the slave cylinders, such that corrective action is achieved by elevating the slave pistons. The curable polymer transitions to a second solid state upon curing such that the corrective elevation of the slave pistons is locked in place. Such an equivalent curable polymer is a polymer that is cured through the application of either visible or ultraviolet light or other radiation source which activates the polymer to transition to a solid state. Another methyl methacrylate liquid polymer when combined with powder becomes a viscous fluid as soon as the powder and liquid are blended; it is initially thin and free flowing. Gradually, in minutes, it begins to thicken, transforming state through paste and puddy to cement-like solid once inside the pistons, thus fixing the SEC at a precise correction amount in its expanded position.

An example of such a light curable polymer is UV10LC-12 made by MASTER BOND Inc., of Hackensack, N.J. Such polymers are characterized by a fast cure time upon exposure to a visible or a UV light source. Depending upon the intensity of the light source, cure times range from a few seconds to less than a minute. As is well understood by one skilled in the art, an extremely thin fiber optic line may be incorporated as an additional line along with the multiple hydraulic lines shown in FIGS. **10A** and **10B** for conveying light from a light source directly to the polymer in the slave cylinders to effect curing.

Alternatively, a curable polymer may be activated by a radiation source such as low level electron beam radiation to cure or initiate curing. An electron beam advantageously can penetrate through material that is opaque to UV light and can be applied directly to lock the pistons in their elevated or corrective position.

It will be appreciated that the amount of applied stress required to cause failure of the corrective implant is substantial due to the confinement of the cured polymer completely within the body of the implant, that is, the cylinder block that is comprised of 6-4 titanium. This is particularly advantageous since the confinement within the titanium body enables the corrective position of the implant to withstand compressive forces up to the structural failure limit of the titanium body; that is, to withstand compressive forces in a range of from 8000 up to 12,000 Newtons.

Referring to FIGS. **10A** and **10B**, a hydraulic line **200** is provided for remote hydraulic control of a plurality of slave cylinders of the SEC from a master cylinder. Hydraulic line **200** comprises a plurality of individual hydraulic lines **202** disposed about a central axis. Each hydraulic line **202** provides independent activation of a separate slave cylinder from a master cylinder as previously explained. A bone graft supply line **204** is provided along the central axis of line **200**. Individual hydraulic lines **202** can be aligned and connected

with corresponding slave cylinder input ports prior to insertion of the SEC for providing independent hydraulic control to each of the slave cylinders. A threaded end **206** can be inserted into a similarly threaded central input port **116** of the SEC to prevent pull out.

In a further alternative embodiment of the present invention, as illustrated for example in FIGS. **11-15**, SEC **300** includes a block or body **306** defining cylinders **308** for receiving pistons cooperating with a top plate **324** substantially as previously described. The body **306** of SEC **300** also defines a central cavity **314** to receive bone graft material for communication with the intervertebral space when implanted. Top plate **324** also provides a central opening aligned with central cavity **314** to facilitate such communication. As shown, for example in FIG. **11**, top plate **324** may be provided with a textured bone engagement surface **311** on the superior surface thereof and the central opening may be shaped to match the shape of central cavity **314**. The textured surface is configured to provide for greater security and fixation between the vertebral body and SEC **300**, and is not limited to the pattern shown, but may be of any appropriate configuration for enhancing fixation as will be appreciated by persons of ordinary skill in the art.

In this exemplary embodiment, SEC **300** includes a graft infusion port **319** in communication with the central graft cavity **314**, which may be positioned laterally on a proximal face **386** of body **306** as shown in FIG. **11**. Graft infusion port **319** may be located laterally of an attachment port **383**, which is where the insertion tool **380** is connected to the SEC **300** via a threaded connector and rotary actuator **406** (see FIG. **14**). Hydraulic line port **322**, communicating with passages leading to cylinders **308**, may be located laterally opposite attachment port **383** on proximal face **386** to receive hydraulic supply line **402** for actuation of the pistons. Distal face **396**, opposite the attachment port, may present narrowed leading edge to facilitate insertion and placement of SEC **300** between adjacent vertebral bodies.

As shown, for example, in FIGS. **12** and **13**, the graft infusion port **319** communicates with the central cavity **314** through passage **392**, which traverses the proximal wall **394** of block **306**. Graft slurry or other bone growth promoting material infused through the graft port **319** flows directly into the central cavity **314** from passage **392**. The relatively large diameter of port **319** and passage **392** allow for unobstructed flow of material into the central cavity. Depending on the size of the implant and the amount of height to be achieved through extension of the pistons, this can be particularly valuable because the central cavity **314** enlarges as the SEC **300** expands. A free flow of bone graft material with sufficient volume is required to fill the enlarged volume of central cavity **314** after expansion. For example, in an implant with a width of about 18 mm, a length of about 50 mm, and a height of about 8 mm, which is expanded after placement to a height of about 12 mm, passage **392** may have an internal diameter of about 6 mm. In general, to provide an unobstructed flow of bone graft material, particularly in slurry form, passage **392** (and port **319**) may be sized such that the ratio of the diameter of passage to the unexpanded implant height would be in the range of about 55-80% or more specifically about 60-75%.

As previously mentioned, with the graft infusion port **319** located lateral of the attachment port **383**, the bone graft supply line **404** of insertion tool **380** can also be located lateral to the hydraulic lines **402** as shown in FIG. **14**. However, this parallel, lateral arrangement may make insertion tool **380** wider, possibly creating difficulty in passing sensitive neural structures in some anatomies. Where the

lateral width of the insertion tool is of concern, such concern may be addressed by providing the bone graft supply line **404** separate from an insertion tool including only the rotary actuator **406** and hydraulic supply line **402**, such that bone graft supply line **404** may be placed separately and only after the SEC **300** is implanted and expanded, and the insertion tool removed, as shown in FIG. **15**. In this case, a collar may be provided that also attaches in attachment port **319** to provide additional security for the bone graft supply line attachment.

In summary, remote hydraulic control of a spinal implant is particularly advantageous in a posterior insertion procedure because there is no anatomic room for mechanical linkage or tooling in the proximity of the adjacent spinal cord and neurovascular complex. The hydraulic control provided by the present invention provides significant mechanical leverage and thus increased force to an extent that has not previously been possible. Further, such hydraulic force is selective in both direction and magnitude of its application.

It is now possible to expand fenestrated endplates to support the anterior spinal column. This will create immediate and reliable firm fixation that will lead to immediate stabilization of the functional spinal motion segment, and immediate correction of complex interbody deformities in the sagittal and coronal plane.

The SEC provides advantages over currently existing technology that include correction of coronal plane deformity; introduction of interbody lordosis and early stabilization of the interbody space with rigidity that is greater than present spacer devices. This early stability may improve post-operative pain, preclude the need for posterior implants including pedicle screws, and improve the rate of successful arthrodesis. Importantly, the SEC provides improvement of space available for the neural elements while improving lordosis. Traditional implants are limited to spacer effects, as passive fillers of the intervertebral disc locations awaiting eventual fusion if and when bone graft in and around the implant fuses. By expanding and morphing into the calculated shape which physiologically corrects spine angulation, the SEC immediately fixes the spine in its proper, painless, functional position. As infused osteoinductive/osteoconductive bone graft materials heal, the patient becomes well and the implant becomes inert and quiescent, embedded in bone, and no longer needed.

While the invention has been described in connection with what are presently considered to be the most practical and preferred embodiments, it is to be understood that the invention is not limited to the disclosed exemplary embodiments and alternatives as set forth above, but on the contrary is intended to cover various modifications and equivalent arrangements included within the scope of the following claims.

For example, equivalent expansion surfaces can be provided for stabilizing the expanding SEC against the bone. Other compositions of additives may be used for the hydraulic fluid that achieves remote controlled expansion of the SEC in three dimensions. Similarly, various types of biogenic fluid material for enhancing bone growth may be injected through one or more lines to the SEC and different exit apertures may be provided to apply bone graft material to fill the intervertebral space, without departing from the scope of the invention.

The implant itself can be made of, for example, such materials as titanium, 64 titanium, or an alloy thereof, 316 or 321 stainless steel, biodegradable and biologically active materials, e.g. stem cells, and polymers, such as semi-

15

crystalline, high purity polymers comprised of repeating monomers of two ether groups and a key tone group, e.g. polyaryetheretherketone (PEEK)TM, or teflon.

Finally, the implant may provide two or more pistons that are operated concurrently to provide coordinated medial/ lateral adjustment of a patient's spine for scoliosis, with anterior/posterior adjustment of the patient's spine to create natural lordosis, with relative anterior expansion greater than posterior expansion.

Therefore, persons of ordinary skill in this field are to understand that all such equivalent processes, arrangements and modifications are to be included within the scope of the following claims.

Exemplary embodiments have been disclosed above and illustrated in the accompanying drawings. It will be understood by those skilled in the art that various changes, omissions and additions may be made to that which is specifically disclosed herein without departing from the spirit and scope of the present invention.

What is claimed is:

1. An apparatus for providing spinal correction, comprising:

an implant body configured and dimensioned for placement in an intervertebral space between a first vertebral body and a second vertebral body, the implant body having a first surface arranged to contact the first vertebral body when the implant body is located in the intervertebral space, the implant body including a side wall extending transverse to the first surface, and the implant body including an interior cavity therein;

a first extendable member and a second extendable member connected to the implant body, and a plate comprising a second surface mounted on the first and second extendable members, the first and second extendable members being independently extendable from a respective unexpanded height to at least one respective expanded height so as to translate the second surface away from the first surface, the second surface being arranged to contact the second vertebral body;

a bone graft material supply port disposed on the implant body, the bone graft material supply port communicating with the interior cavity such that bone graft material can be supplied to the interior cavity through the bone graft material supply port; and

a connector disposed on the implant body, the connector having an interlocking structure configured to detachably interlock with a corresponding interlocking structure of an insertion tool;

wherein the bone graft material supply port and the connector are both disposed on a proximal portion of the implant body, the bone graft material supply port and the connector being spaced apart laterally along the side wall of the implant body.

2. The apparatus of claim 1, wherein the interior cavity is disposed between the first and second extendable members.

3. The apparatus of claim 1, wherein the plate includes an opening in communication with the interior cavity such that bone graft material from the interior cavity can pass through the opening in the plate for infusion into the intervertebral space.

4. The apparatus of claim 1, wherein the first and second extendable members each include a piston slidably received within a cylinder of the implant body.

5. The apparatus of claim 4, wherein the implant body further includes a hydraulic supply port in communication with the cylinders, the hydraulic supply port being disposed on a proximal portion of the implant body.

16

6. The apparatus of claim 1, wherein the first and second extendable members each include a piston slidably received within a cylinder of the implant body, and wherein the implant body further includes a hydraulic supply port in communication with the cylinders, the hydraulic supply port being spaced apart laterally along the side wall of the implant body from the bone graft material supply port and the connector.

7. The apparatus of claim 1, wherein the bone graft material supply port has a diameter in the range of 55% to 80% of the unexpanded height.

8. An apparatus for providing spinal correction, comprising:

an implant body configured and dimensioned for placement in an intervertebral space between a first vertebral body and a second vertebral body, the implant body having a first surface arranged to contact the first vertebral body when the implant body is located in the intervertebral space, the implant body including a side wall extending transverse to the first surface, and the implant body including an interior cavity therein;

at least one extendable member connected to the implant body, the at least one extendable member being extendable from an unexpanded height to at least one expanded height so as to translate a second surface away from the first surface, the second surface being arranged to contact the second vertebral body;

a bone graft material supply port defined in the side wall of the implant body, the bone graft material supply port communicating with the interior cavity such that bone graft material can be supplied to the interior cavity through the bone graft material supply port; and

a connector disposed on the side wall of the implant body, the connector defined by an opening in the side wall, the opening having an interlocking structure positioned therein, the interlocking structure configured to detachably interlock with a corresponding interlocking structure of an insertion tool;

wherein the bone graft material supply port and the connector are spaced apart laterally along the side wall of the implant body such that an axis along which the bone graft material supply port is defined is noncollinear with an axis along which the opening of the connector is defined, and wherein the side wall in which both the bone graft material supply port and the opening of the connector are defined is a monolithic structure.

9. The apparatus of claim 8, wherein the at least one extendable member comprises a first extendable member and a second extendable member.

10. The apparatus of claim 9, wherein the interior cavity is disposed between the first and second extendable members.

11. The apparatus of claim 9, wherein a plate comprising the second surface is mounted on the first and second extendable members.

12. The apparatus of claim 11, wherein the plate includes an opening in communication with the interior cavity such that bone graft material from the interior cavity can pass through the opening in the plate for infusion into the intervertebral space.

13. The apparatus of claim 8, wherein the at least one extendable member includes a piston slidably received within a cylinder of the implant body.

14. The apparatus of claim 13, wherein the implant body further includes a hydraulic supply port in communication with the cylinder, the hydraulic supply port being spaced

apart laterally along the side wall of the implant body from the bone graft material supply port and the connector.

15. The apparatus of claim 8, wherein the at least one extendable member includes a piston slidably received within a cylinder of the implant body, wherein the implant 5 body further includes a hydraulic supply port in communication with the cylinder, and wherein the bone graft material supply port, the connector, and the hydraulic supply port are all disposed on a proximal portion of the implant body.

16. The apparatus of claim 8, wherein the bone graft 10 material supply port has a diameter in the range of 55% to 80% of the unexpanded height.

17. The apparatus of claim 8, wherein the implant body has an elongated shape along a longitudinal axis extending along the first surface of the implant body. 15

* * * * *