

(12) **United States Patent**
Moloney et al.

(10) **Patent No.:** **US 10,574,890 B2**
(45) **Date of Patent:** **Feb. 25, 2020**

(54) **METHODS AND APPARATUS TO OPERATE A MOBILE CAMERA FOR LOW-POWER USAGE**

(71) Applicant: **Movidius LTD.**, Dublin (IE)

(72) Inventors: **David Moloney**, Dublin (IE); **Alireza Deghani**, Dublin (IE)

(73) Assignee: **Movidius Ltd.**, Dublin (IE)

(*) Notice: Subject to any disclaimer, the term of this patent is extended or adjusted under 35 U.S.C. 154(b) by 0 days.

(21) Appl. No.: **15/870,007**

(22) Filed: **Jan. 12, 2018**

(65) **Prior Publication Data**
US 2019/0222756 A1 Jul. 18, 2019

(51) **Int. Cl.**
H04N 7/18 (2006.01)
H04N 5/232 (2006.01)
(Continued)

(52) **U.S. Cl.**
CPC **H04N 5/23241** (2013.01); **G06F 16/164** (2019.01); **G06K 9/00255** (2013.01); **G06K 9/00288** (2013.01); **G06K 9/00335** (2013.01); **G06K 9/209** (2013.01); **G06K 9/6202** (2013.01); **G06K 9/66** (2013.01); **G06N 3/02** (2013.01);
(Continued)

(58) **Field of Classification Search**
CPC .. H04N 7/18; H04N 5/23241; H04N 5/23219; H04N 7/188; G06F 16/164; G06K 9/00255; G06K 9/00288; G06K 9/00335; G06K 9/209; G06K 9/6202; G06K 9/66;
(Continued)

(56) **References Cited**

U.S. PATENT DOCUMENTS

8,345,921 B1 1/2013 Frome et al.
8,508,520 B2 * 8/2013 Porwal G09G 3/3406 345/102

(Continued)

FOREIGN PATENT DOCUMENTS

WO 2018033890 2/2018

OTHER PUBLICATIONS

“International Search Report,” issued by the European Patent Office as International Searching Authority dated Mar. 7, 2019 in connection with International Application No. PCT/EP2019/050462 (7 pages).

(Continued)

Primary Examiner — Trang U Tran

(74) *Attorney, Agent, or Firm* — Hanley, Flight & Zimmerman, LLC

(57) **ABSTRACT**

An example mobile camera includes a first convolutional neural network to recognize a first feature in first sensor data in response to the first feature being detected in the first sensor data; a state transitioner to transition the mobile camera from a first feature detection state to a second feature detection state in response to the first convolutional neural network recognizing the first feature, the mobile camera to operate using higher power consumption in the second feature detection state than in the first feature detection state; a second convolutional neural network to recognize a second feature in second sensor data in the second feature detection state; and a communications interface to send to an external device at least one of first metadata corresponding to the first feature or second metadata corresponding to the second feature.

25 Claims, 10 Drawing Sheets

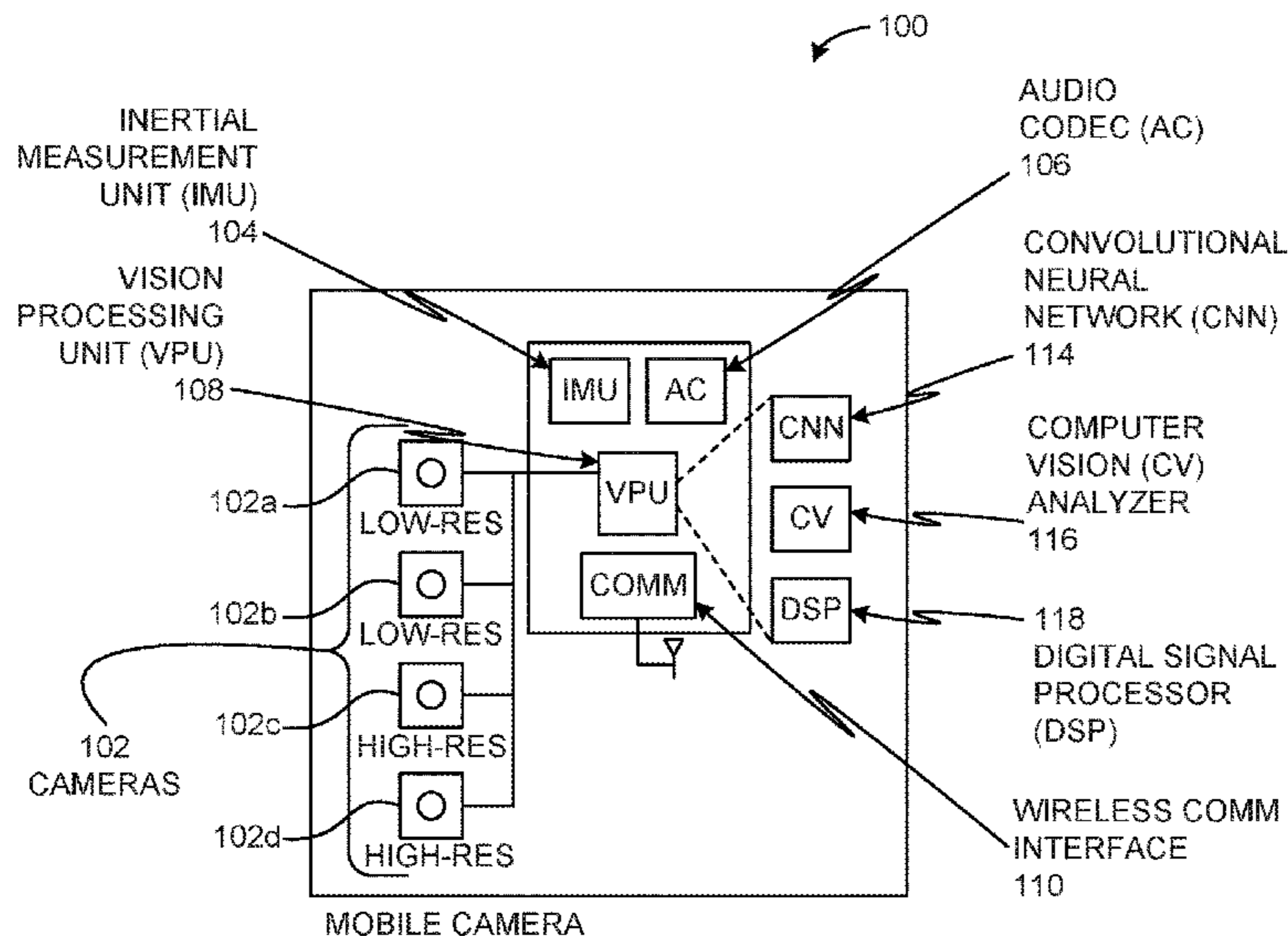

- (51) **Int. Cl.**
- | | | | | |
|-------------------|-----------|------------------|---------|-------------------------|
| <i>G06K 9/00</i> | (2006.01) | 2016/0037110 A1 | 2/2016 | Choi et al. |
| <i>G06K 9/20</i> | (2006.01) | 2017/0161579 A1 | 6/2017 | Gousev et al. |
| <i>G06K 9/62</i> | (2006.01) | 2017/0353699 A1 | 12/2017 | Wang |
| <i>G06K 9/66</i> | (2006.01) | 2018/0196587 A1* | 7/2018 | Bialynicka-Birula |
| <i>G06N 3/02</i> | (2006.01) | | | H04N 1/215 |
| <i>G10L 19/00</i> | (2013.01) | 2018/0232580 A1 | 8/2018 | Wolf |
| <i>G10L 25/51</i> | (2013.01) | | | |
| <i>G10L 25/78</i> | (2013.01) | | | |
| <i>H04N 5/225</i> | (2006.01) | | | |
| <i>G06F 16/16</i> | (2019.01) | | | |
| <i>G10L 15/16</i> | (2006.01) | | | |

OTHER PUBLICATIONS

“Written Opinion,” issued by the European Patent Office as International Searching Authority dated Mar. 7, 2019 in connection with International Application No. PCT/EP2019/050462 (10 pages).

“Automatic Musical Pattern Feature Extraction Using Convolutional Neural Network,” Li et al., Proceedings of the International MultiConference of Engineers and Computer Scientists, 2010 vol. I, IMECS 2010, Mar. 17-19, 2010, Hong Kong (5 pages).

“Neural Network Architectures for Motion Perception and Elementary Motion Detection in the Fly Visual System,” Ogmen et al., Neural Networks, vol. 3, pp. 487-505, 1990.

“VoxNet: A 3D Convolutional Neural Network for Real-Time Object Recognition,” Maturana et al., 2015 IEEE/RSJ International Conference on Intelligent Robots and Systems (IROS), Congress Center Hamburg, Sep. 28-Oct. 2, Hamburg, Germany (7 pages).

Phong, Le Trieu, “Privacy-Preserving Stochastic Gradient Descent with Multiple Distributed Trainers,” International Conference on Computer Analysis of Images and Patterns (CAIP), 2017, pp. 510-518, 9 pages.

McMahan et al, “Communication-Efficient Learning of Deep Networks from Decentralized Data,” Feb. 28, 2017, pp. 1-11. Retrieved from the Internet on Jan. 7, 2019 [https://arxiv.org/pdf/1602.05629.pdf], 11 pages.

Chen et al., “Adaptive Silhouette Extraction and Human Tracking in Complex and Dynamic Environments,” IEEE International Conference on Image Processing, Atlanta, GA, Oct. 8-11, 2006, 4 pages.

Dehghani et al., “EoT Device with Factor Form Board,” Nov. 15, 2016, 57 pages. Retrieved from the Internet at http://eyesofthings.eu/wp-content/uploads/deliverables/EoT_D2.6.pdf.

- (52) **U.S. Cl.**
- CPC *G10L 19/00* (2013.01); *G10L 25/51* (2013.01); *G10L 25/78* (2013.01); *H04N 5/2258* (2013.01); *H04N 5/23218* (2018.08); *H04N 5/23219* (2013.01); *H04N 5/23245* (2013.01); *H04N 5/232411* (2018.08); *G06K 9/00221* (2013.01); *G06K 9/2081* (2013.01); *G10L 15/16* (2013.01)
- (58) **Field of Classification Search**
- CPC G06N 3/02; G10L 19/00; G10L 25/51; G10L 25/78
- USPC 348/77, 220.1, 231.1–231.3
- See application file for complete search history.

(56) **References Cited**

U.S. PATENT DOCUMENTS

9,471,840 B2	10/2016	Govil et al.	
9,934,781 B2 *	4/2018	Subhojit	G10L 15/06
10,225,511 B1 *	3/2019	Lim	G06K 9/66
2014/0368626 A1	12/2014	John Archibald et al.	
2015/0172539 A1	6/2015	Neglur	
2015/0324686 A1	11/2015	Julian et al.	
2016/0034809 A1 *	2/2016	Trenholm	H04L 41/5041
			706/20

* cited by examiner

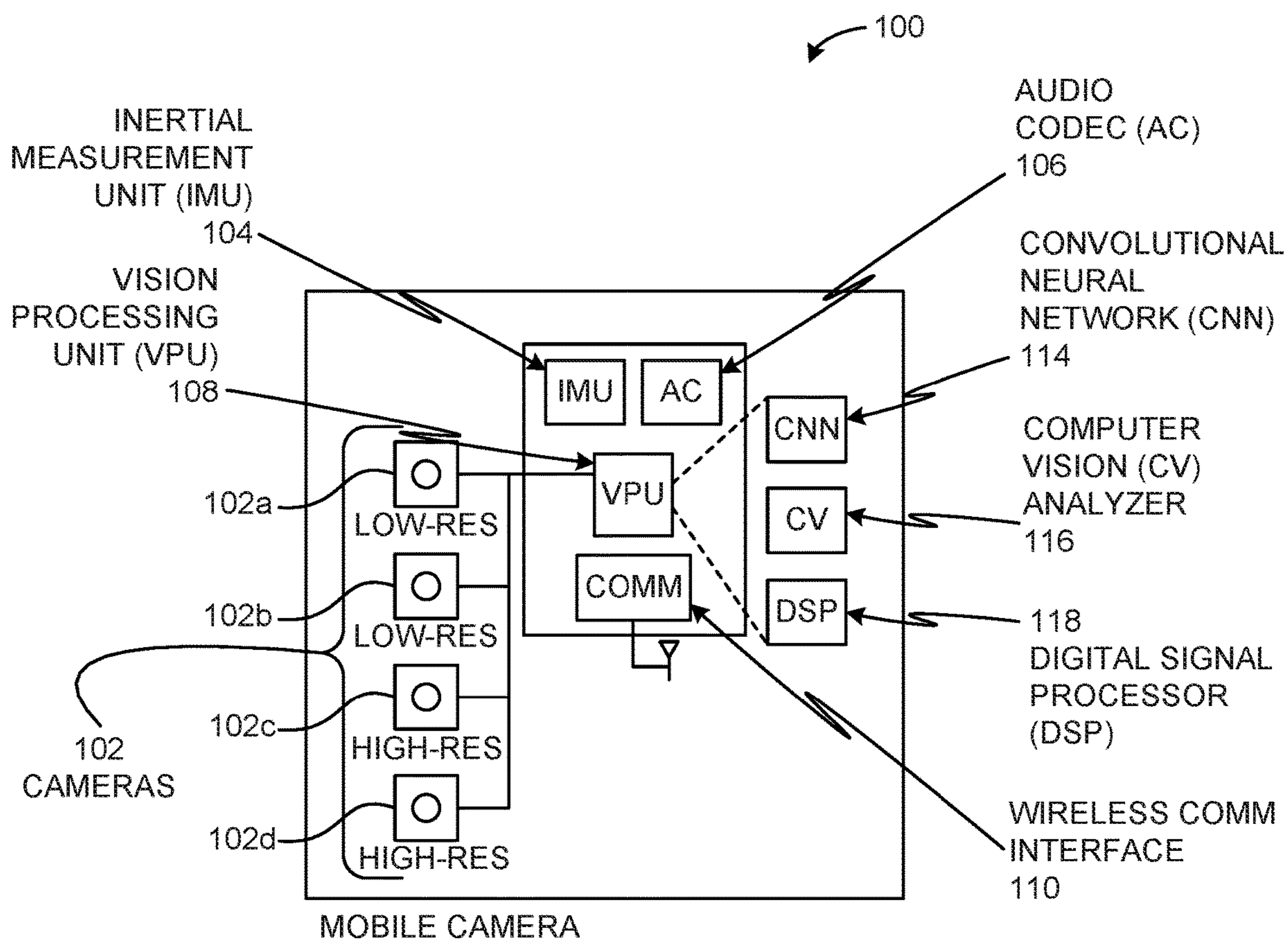

FIG. 1A

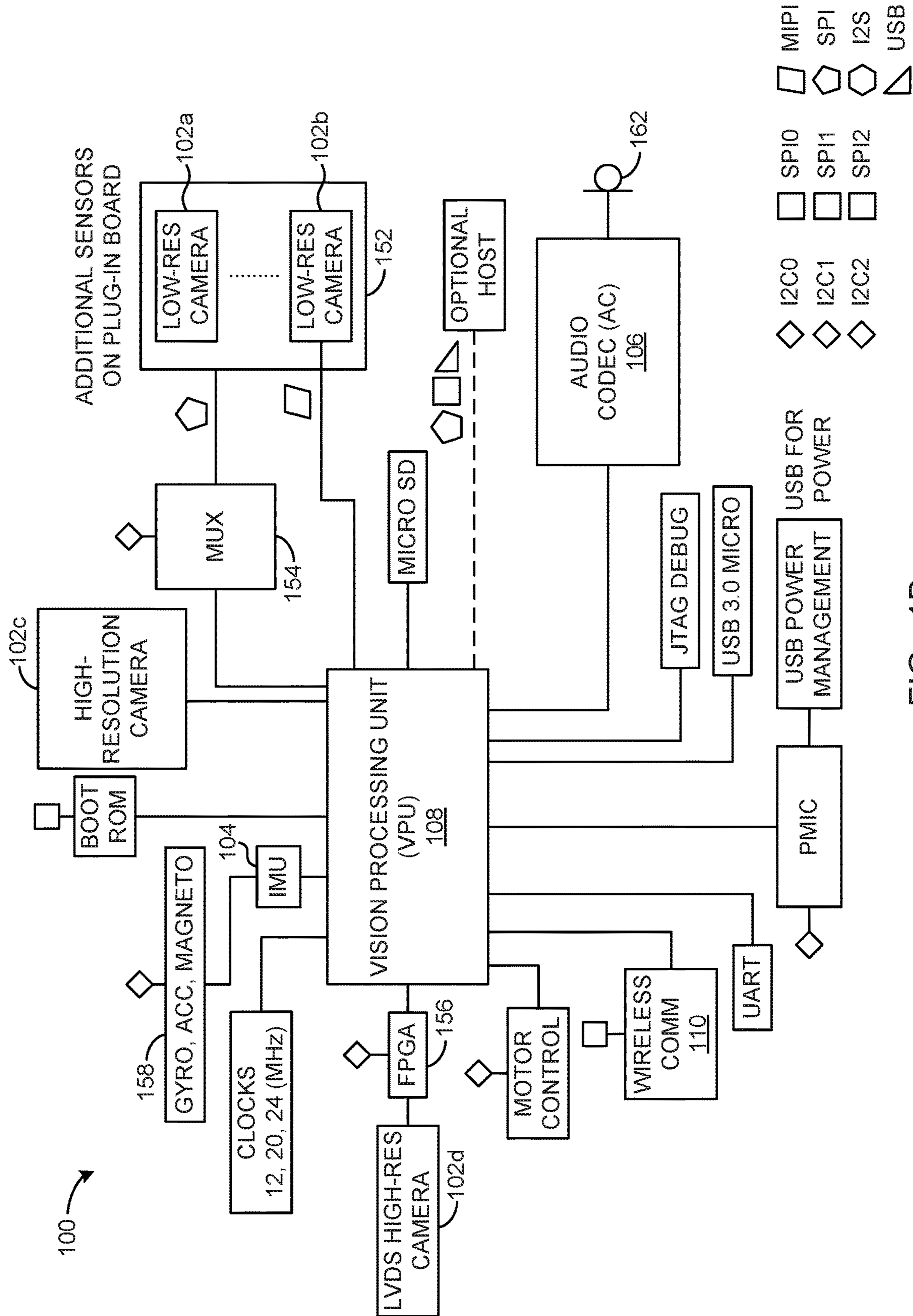

FIG. 1B

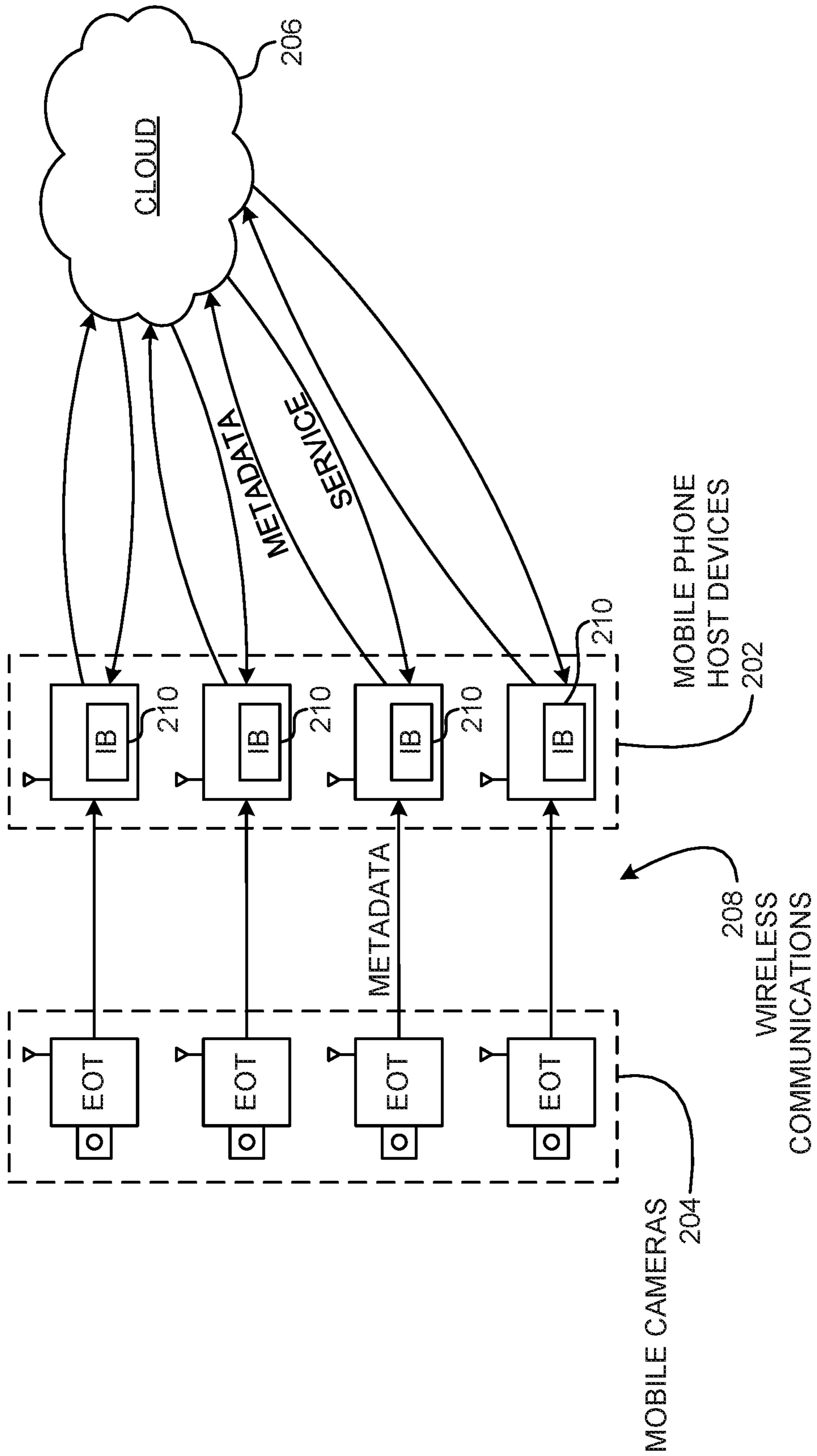

FIG. 2

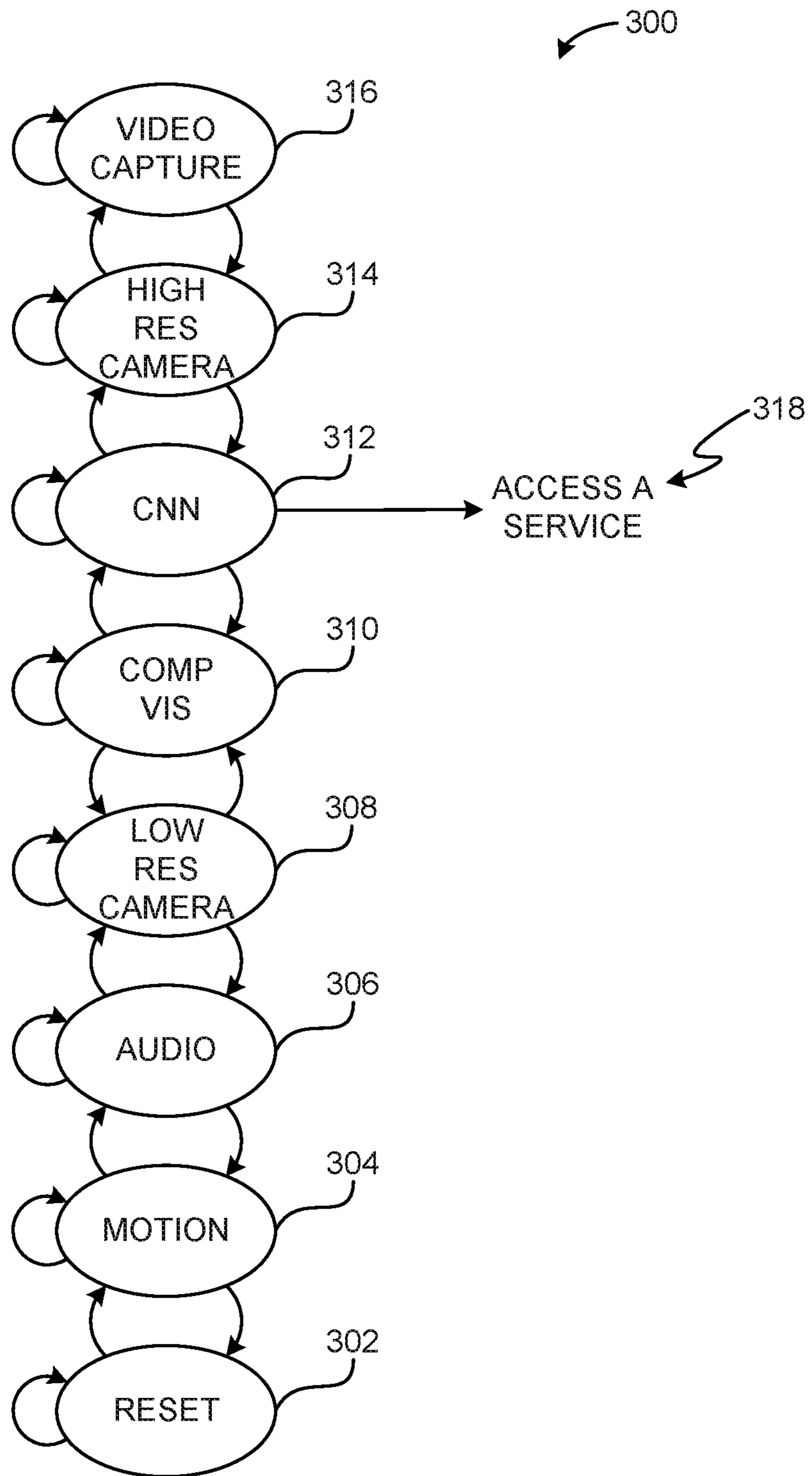

FIG. 3

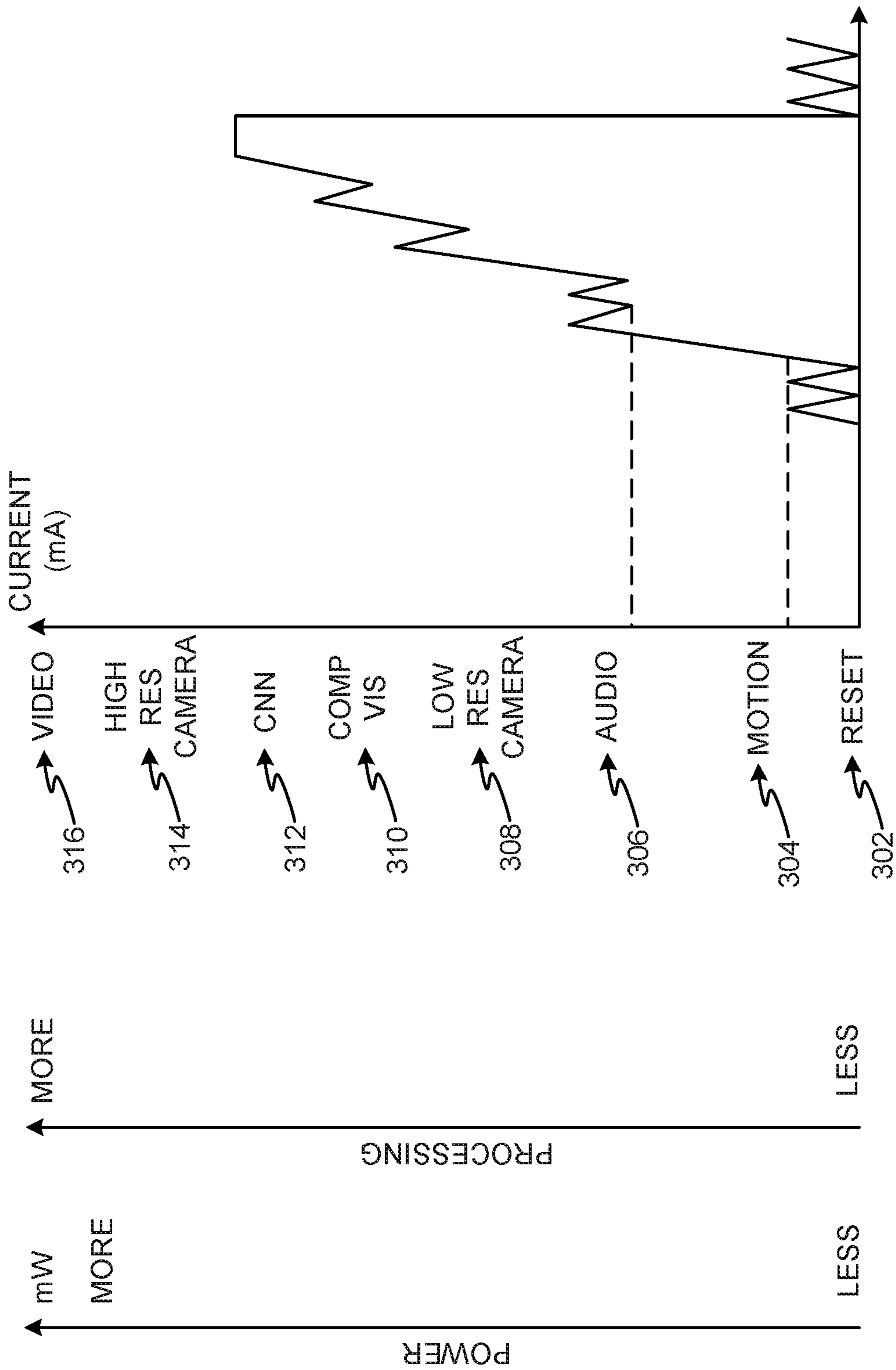

FIG. 4

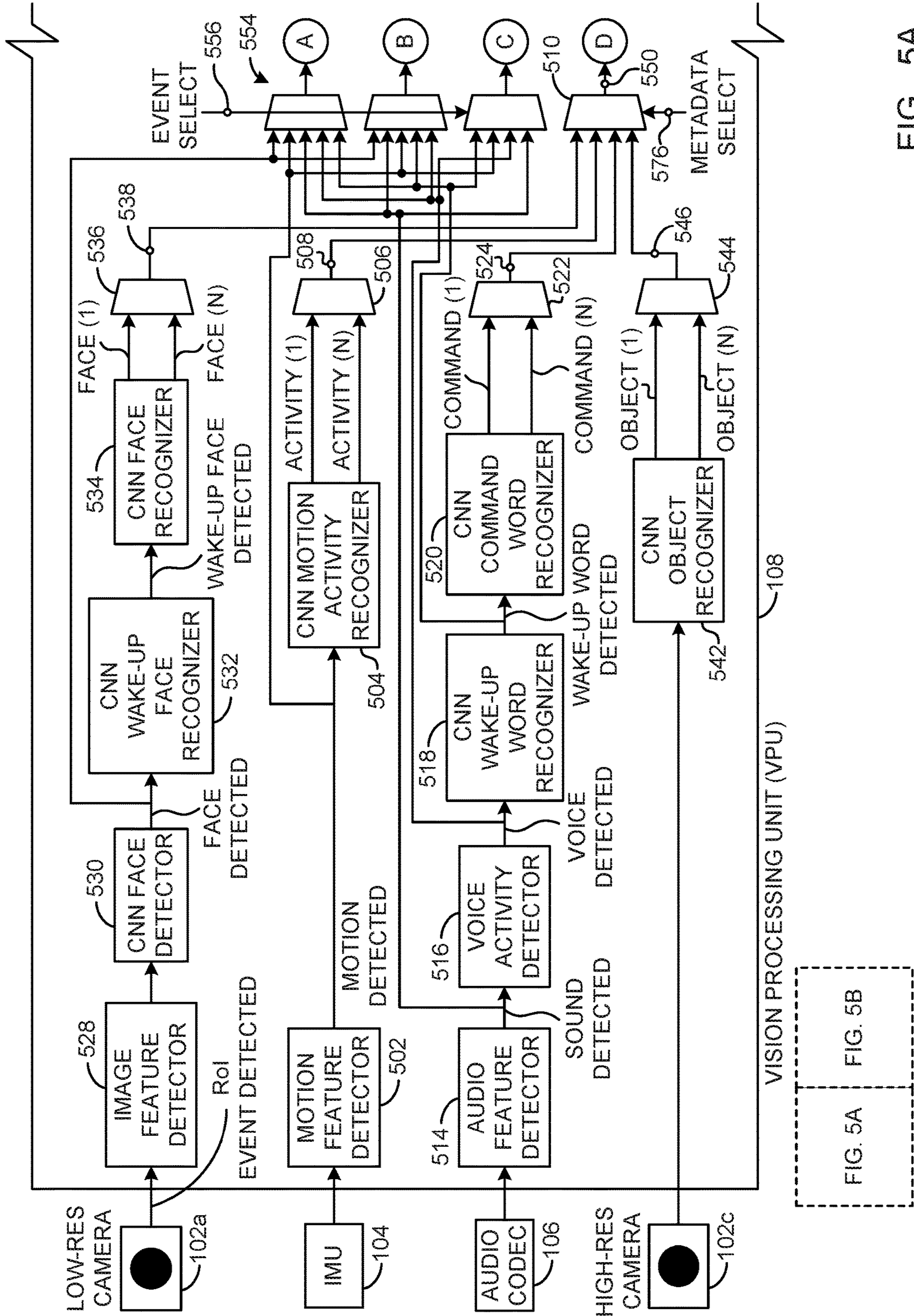

FIG. 5A

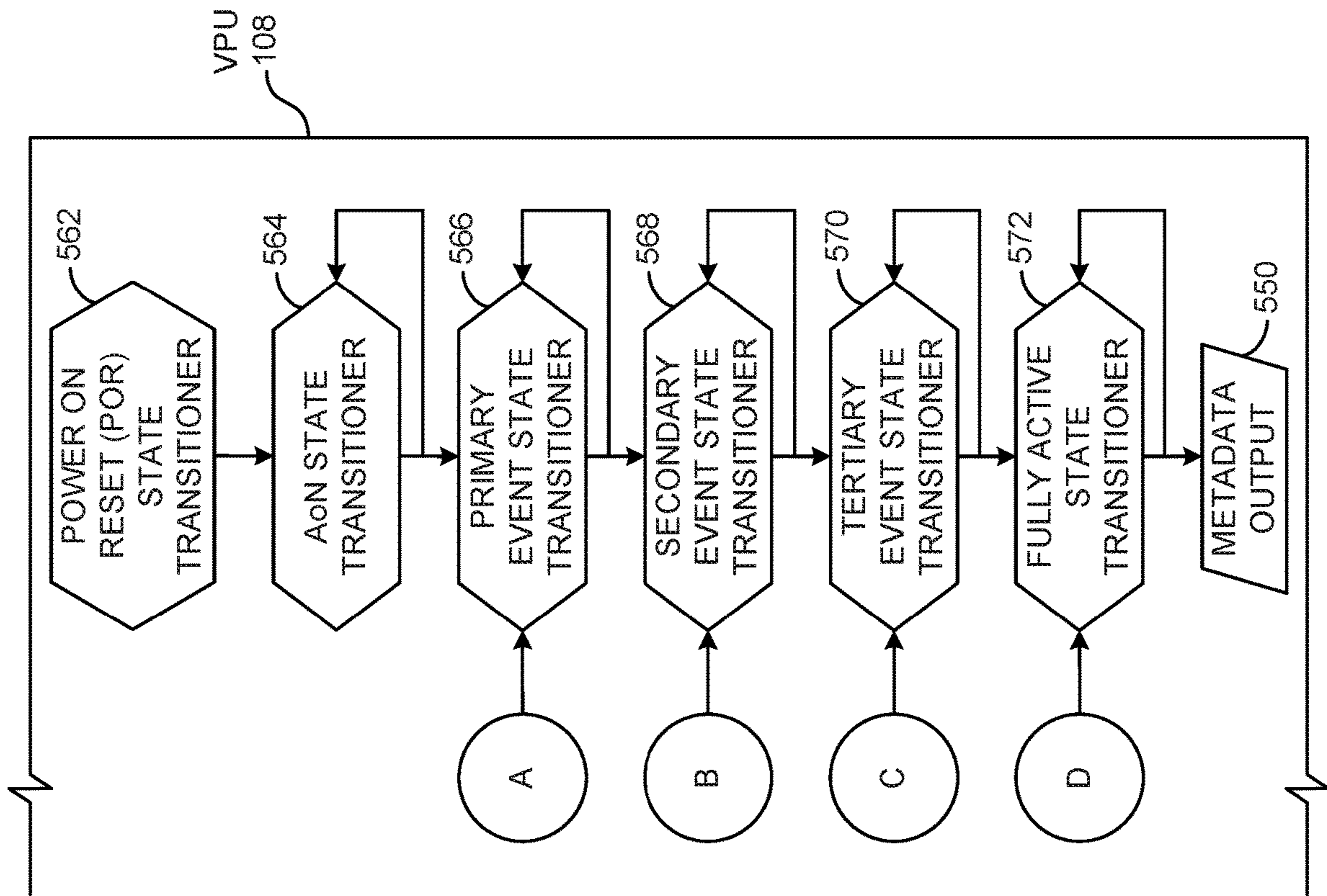

FIG. 5B

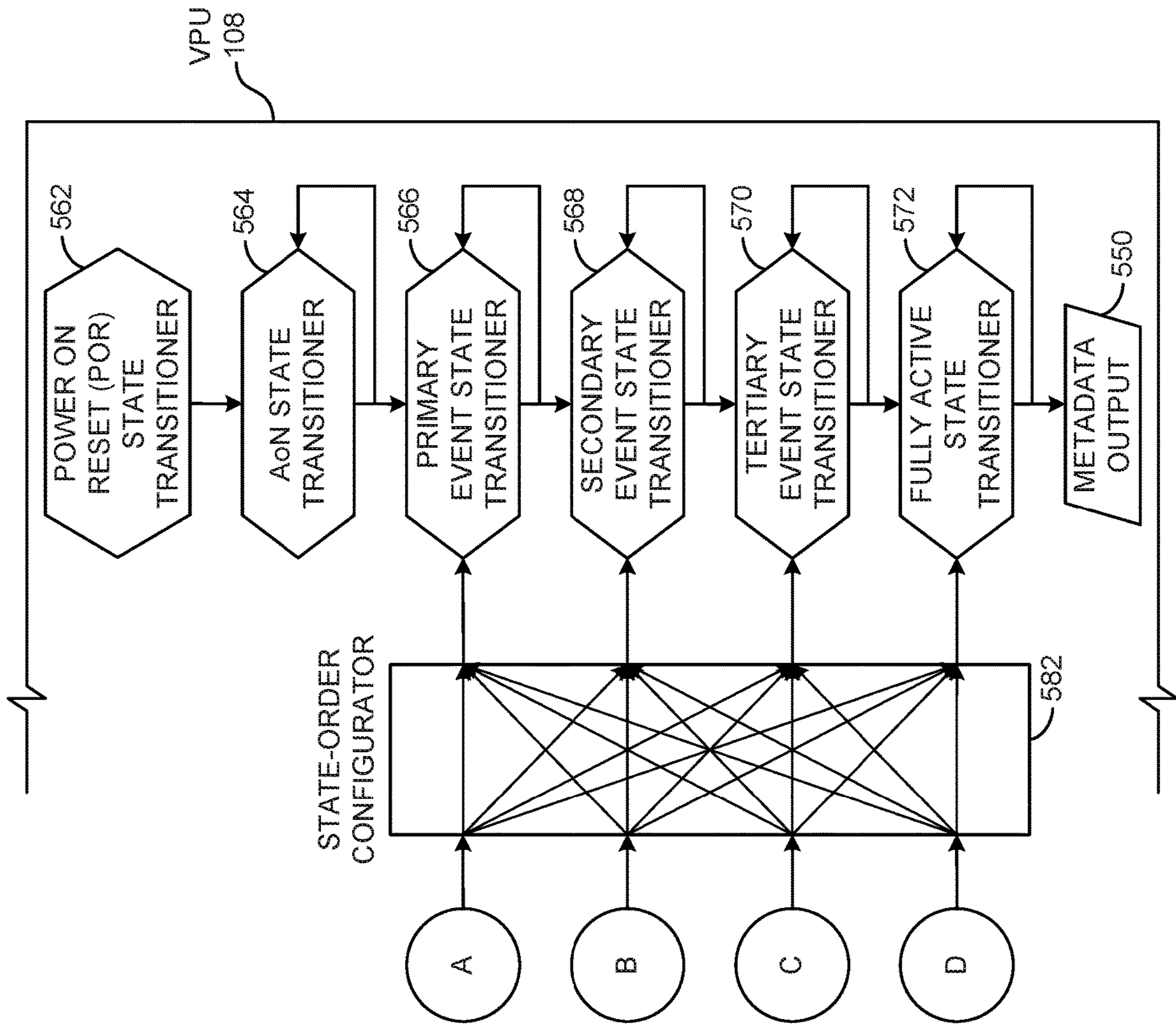

FIG. 5C

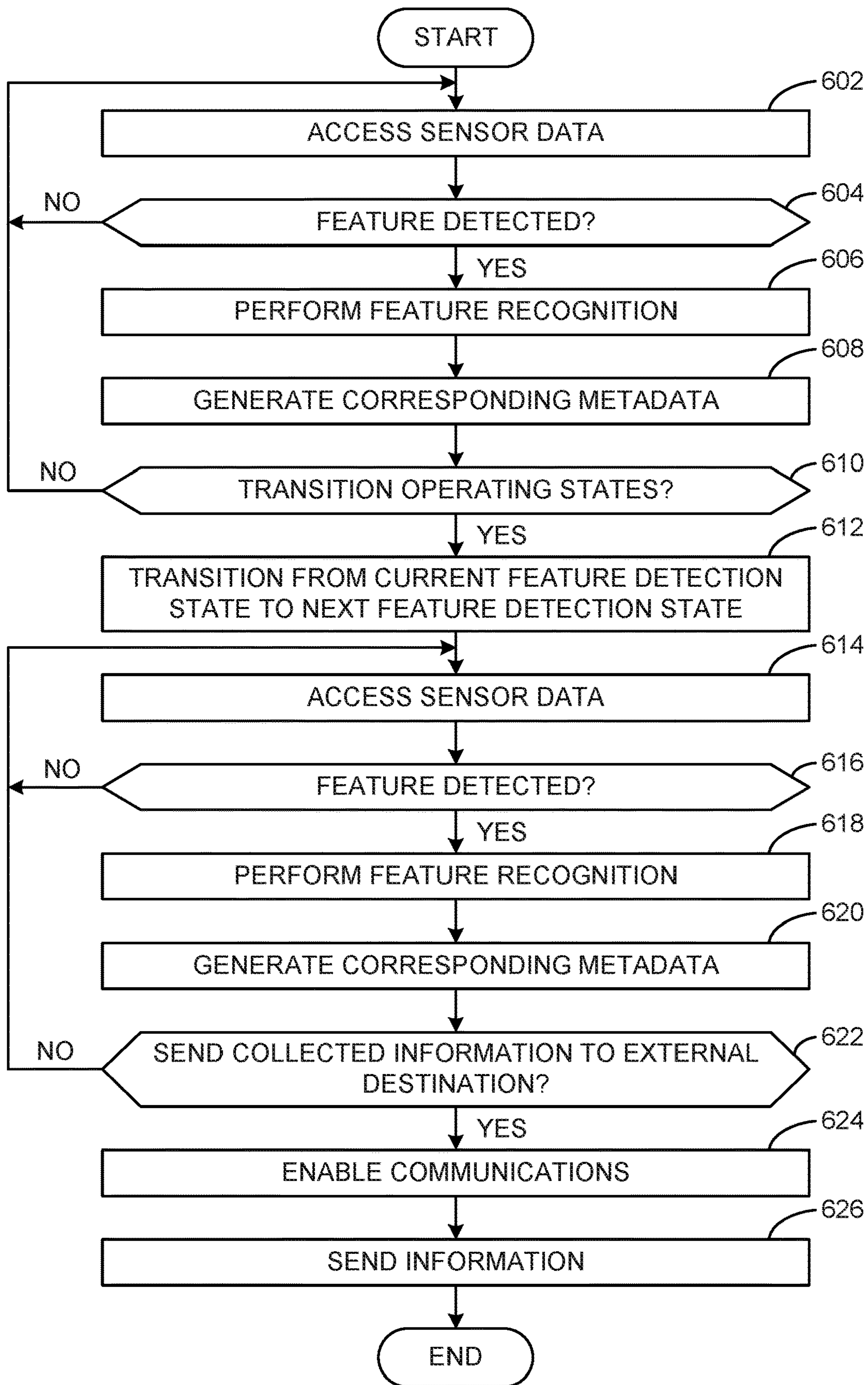

FIG. 6

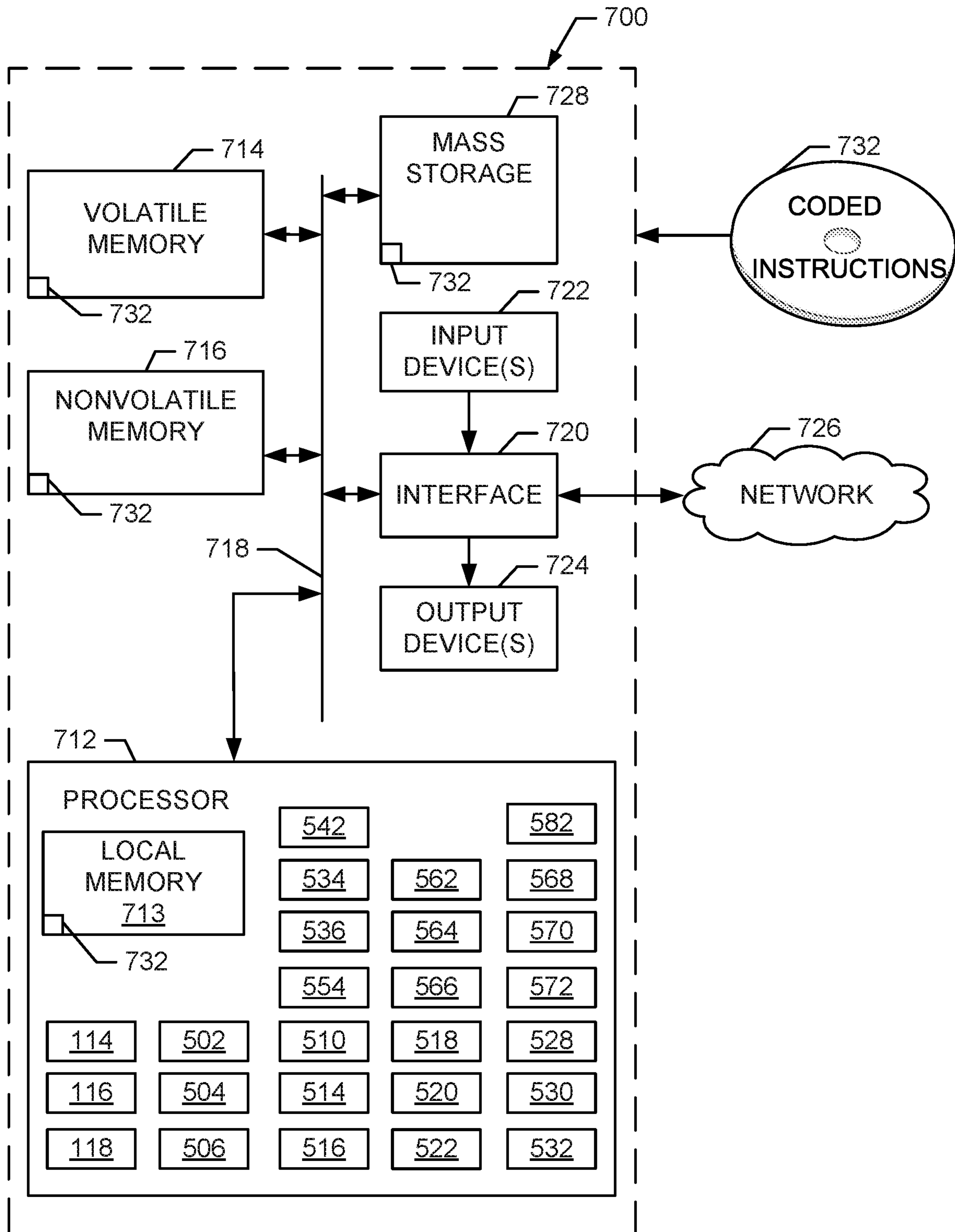

FIG. 7

1**METHODS AND APPARATUS TO OPERATE
A MOBILE CAMERA FOR LOW-POWER
USAGE**

FIELD OF THE DISCLOSURE

This disclosure is generally related to mobile computing, and more specifically to methods and apparatus to operate a mobile camera for low-power usage.

BACKGROUND

Digital cameras are often integrated into handheld mobile computing devices such as cellular telephones and handheld media devices. Digital cameras are also often integrated into other types of computing devices such as tablet computing devices and laptop computers. Such digital cameras are operated by users to capture digital images and videos. Digital images and videos can be stored locally at a memory of the computing device in which the digital camera is integrated, or they can be sent to a network-accessible storage location across a public network such as the Internet or across a private network. In any case, the digital images and videos may be subsequently accessed by the originators of those images and videos or by other persons having access privileges.

BRIEF DESCRIPTION OF THE DRAWINGS

FIG. 1A illustrates an example mobile camera implemented in accordance with teachings of this disclosure.

FIG. 1B illustrates an example hardware platform that may be used to implement the mobile camera shown in FIG. 1A.

FIG. 2 illustrates example mobile phone host devices in wireless communication with corresponding mobile cameras and a cloud system.

FIG. 3 illustrates an example multiple power-level operating state hierarchy for use with the mobile cameras of FIGS. 1A, 1B, and 2.

FIG. 4 illustrates a line graph of example power usage by the mobile cameras of FIGS. 1A, 1B, and 2 at the different power-level operating states of FIG. 3.

FIGS. 5A and 5B depict an example implementation of the vision processing unit (VPU) of FIGS. 1A and 1B that may be used in the mobile cameras of FIGS. 1A, 1B, and 2 to operate at the different power-level operating states of FIG. 3 in accordance with teachings of this disclosure.

FIG. 5C depicts an example state-order configurator that may be used with the VPU depicted in FIGS. 5A and 5B to configure the ordering of the different power-level operating states of FIG. 3.

FIG. 6 illustrates a flowchart representative of example machine-readable instructions that may be executed to implement the mobile cameras of FIGS. 1A, 1B, and 2 and/or the VPU 108 of FIGS. 1A, 1B, 5A, 5B, and 5C to operate at the different power-level operating states of FIG. 3.

FIG. 7 illustrates a processor platform capable of executing the machine-readable instructions of FIG. 6 to implement the mobile cameras of FIGS. 1A, 1B, and 2 and/or the VPU 108 of FIGS. 1A, 1B, 5A, 5B, and 5C to operate at the different power-level operating states of FIG. 3.

The figures are not to scale. Instead, for purposes of clarity, different illustrated aspects may be enlarged in the drawings. In general, the same reference numbers will be

2

used throughout the drawings and accompanying written description to refer to the same or like parts.

DETAILED DESCRIPTION

5

Example methods and apparatus disclosed herein operate mobile cameras with low-power usage. Examples disclosed herein may operate mobile cameras which have limited power sources while enabling numerous uses for the mobile cameras for productivity, entertainment, and/or as technologies that assist users in their day-to-day activities (e.g., assistive technologies). Example mobile cameras disclosed herein operate in a low-power feature monitoring mode and one or more higher-power active modes. The low-power feature monitoring mode enables a mobile camera to monitor characteristics of its surrounding environment while consuming little power (e.g., ~2 milliwatts or less). In the low-power feature monitoring mode, environment analysis logic of an example mobile camera monitors environmental characteristics to identify features of interest representing stimuli that warrant transitioning the mobile camera to a higher-power active mode in which the mobile camera can monitor additional types of environmental characteristics and/or capture one or more high-quality visual captures. As used herein, “visual captures” are images and/or video captured by one or more cameras. In examples disclosed herein involving the processing of a visual capture, the visual capture may be a single image capture or may be a frame that is part of a sequence of frames of a video capture.

Example environmental characteristics monitored by mobile cameras disclosed herein include visual characteristics, audio characteristics, and/or motion characteristics. To monitor such environmental characteristics, example mobile cameras disclosed herein are provided with multiple sensors. Example sensors include cameras, microphones, and/or motion detectors. Other types of sensors may also be provided without departing from the scope of this disclosure. By using a low-power feature monitoring mode to monitor environmental characteristics, examples disclosed herein enable mobile cameras to operate for long durations (e.g., days or weeks) at relatively low rates of battery drain.

Examples disclosed herein also enable such power-conservative mobile cameras to intelligently detect when to transition into one or more higher-power active modes based on one or more detected environmental stimuli. That is, examples disclosed herein identify some environmental stimuli as trigger features that, when detected, indicate that a mobile camera is to be transitioned to a higher-power active mode to enable additional functionality of the mobile camera. For example, in a lowest-power feature monitoring mode, a mobile camera may power its motion detection subsystem and/or its audio monitoring subsystem while maintaining other sensor subsystems in a low-power standby mode. Upon detecting a motion trigger feature (e.g., a threshold amount of movement) and/or an audio trigger feature (e.g., a keyword, a particular sound, an animal sound, a vehicle sound, a human sound, a household sound, an industrial sound, etc.), the mobile camera may transition into a next higher-power mode in which a low-resolution camera is powered to capture low-resolution visual captures. The mobile camera may then analyze the low-resolution visual captures using machine vision processes to monitor for visual trigger features (e.g., faces, objects, vehicles, etc.). Upon detecting a visual trigger feature, the mobile camera may transition into a next higher-power mode in which one or more additional subsystems of the mobile camera are enabled. In some examples, the highest high-power active

mode of the mobile camera may involve enabling one or more high-resolution cameras to capture high-quality visual captures. In such manners, examples disclosed herein enable mobile cameras to operate in power-constrained configurations for long durations while the mobile cameras intelligently operate intermittently in higher-power modes to capture high-quality data such as high-resolution visual captures of their surrounding environments.

FIG. 1A illustrates an example mobile camera 100 that includes a plurality of example cameras 102, an example inertial measurement unit (IMU) 104, an example audio codec (AC) 106, an example vision processing unit (VPU) 108, and an example wireless communication interface 110. FIG. 1B is an example hardware platform that may be used to implement the mobile camera 100 of FIG. 1A. The example mobile camera 100 may be a wearable camera and/or a mountable camera. A wearable camera may be worn or carried by a person. For example, the person may pin or attach the wearable camera to a shirt or lapel, wear the wearable camera as part of eyeglasses, hang the wearable camera from a lanyard around their neck, clip the wearable camera to their belt via a belt clip, clip or attach the wearable camera to a bag (e.g., a purse, a backpack, a briefcase, etc.), and/or wear or carry the wearable camera using any other suitable technique. In some examples, a wearable camera may be clipped or attached to an animal (e.g., a pet, a zoo animal, an animal in the wild, etc.). A mountable camera may be mounted to robots, drones, or stationary objects in any suitable manner to monitor its surroundings.

Example mobile cameras disclosed herein implement eyes on things (EOT) devices that interoperate with an EOT platform with which computers (e.g., servers, client devices, appliances, etc.) across the Internet can communicate via application programming interfaces (APIs) to access visual captures of environments, persons, objects, vehicles, etc. For example, a cloud service (e.g., provided by the cloud system 206) may implement such EOT platform to collect and/or provide access to the visual captures. In some examples, such visual captures may be the result of machine vision processing by the EOT devices and/or the EOT platform to extract, identify, modify, etc. features in the visual captures to make such visual captures more useful for generating information of interest regarding the subjects of the visual captures.

The example cameras 102 are provided to capture visual captures (e.g., images and/or video) and may be implemented using, for example, one or more CMOS (complementary metal oxide semiconductor) image sensor(s) and/or one or more CCD (charge-coupled device) image sensor(s). In the illustrated example of FIGS. 1A and 1B, the plurality of cameras 102 includes two low-resolution cameras 102a,b and two high-resolution cameras 102c,d. However, in other examples, some or all of the cameras 102 may be low resolution, and/or some or all may be high resolution.

Turning briefly to the example of FIG. 1B, the low-resolution cameras 102a,b are in circuit with the VPU 108 via a plug-in board 152 which serves as an expansion board through which additional sensors may be connected to the VPU 108. An example multiplexer 154 is in circuit between the VPU 108 and the plug-in board 152 to enable the VPU 108 to select which sensor to power and/or to communicate with on the plug-in board 152. Also in the illustrated example of FIG. 1B, the high-resolution camera 102c is in circuit directly with the VPU 108. The low-resolution cameras 102a,b and the high-resolution camera 102c may be connected to the VPU via any suitable interface such as a Mobile Industry Processor Interface (MIPI) camera inter-

face (e.g., MIPI CSI-2 or MIPI CSI-3 interface standards) defined by the MIPI® Alliance Camera Working Group, a serial peripheral interface (SPI), an I2C serial interface, a universal serial bus (USB) interface, a universal asynchronous receive/transmit (UART) interface, etc. The high-resolution camera 102d of the illustrated example is shown as a low-voltage differential signaling (LVDS) camera that is in circuit with the VPU 108 via a field programmable gate array (FPGA) 156 that operates as an LVDS interface to convert the LVDS signals to signals that can be handled by the VPU 108. In other examples, the VPU 108 may be provided with a LVDS interface and the FPGA 156 may be omitted. In other examples, any combination of the low-resolution cameras 102a,b and the high-resolution cameras 102c,d may be in circuit with the VPU 108 directly, indirectly, and/or via the plug-in board 152. In any case, the mobile camera 100 can completely power off any or all the cameras 102a-d and corresponding interfaces so that the cameras 102a-d and the corresponding interfaces do not consume power.

In the illustrated examples of FIGS. 1A and 1B, the low-resolution cameras 102a,b consume substantially lower power than the high-resolution cameras 102c,d. As such, in some examples, the low-resolution cameras 102a,b can be implemented as low-power always on (AoN) cameras. To conserve battery power, the mobile camera 100 operates in a low-power feature monitoring mode in which the high-resolution camera(s) 102c,d is/are placed or set in a low-power standby mode (e.g., a mode in which the high-resolution camera(s) 102c,d consume very little power or no power) until the VPU 108 detects a visual feature of interest in one or more visual captures from the low-resolution camera(s) 102a,b. When such a visual feature of interest is detected, the mobile camera 100 transitions to a higher-power active mode in which the high-resolution camera(s) 102c,d is/are placed or set in an active mode to be powered up to capture a higher quality visual capture (e.g., of the visual feature of interest) than is possible of being captured using the low-resolution cameras 102a,b. In this manner, the power consumption attributable to visual monitoring by the mobile camera 100 can be maintained relatively low using examples disclosed herein by using the low-resolution cameras 102a,b during the low-power feature monitoring mode until a feature of interest is detected. Relatively more power drawn by the high-resolution cameras 102c,d need only be provided by the mobile camera 100 when the feature of interest is detected.

In some examples, the multiple cameras 102a-d of the illustrated example may be mechanically arranged to produce visual captures of different overlapping or non-overlapping fields of view. Visual captures of the different fields of view can be aggregated to form a panoramic view of an environment or form an otherwise more expansive view of the environment than covered by any single one of the visual captures from a single camera. In some examples, the multiple cameras 102a-d may be used to produce stereoscopic views based on combining visual captures captured concurrently via two cameras. In some examples, as in FIGS. 1A and 1B, a separate high-resolution camera may be provided for each low-resolution camera. In other examples, a single low-resolution camera is provided for use during a low-power feature monitoring mode, and multiple high-resolution cameras are provided to generate high-quality multi-view visual captures and/or high-quality stereoscopic visual captures when feature of interest confirmations are made using the low-resolution camera. In some examples in which the mobile camera 100 is mounted on non-human

carriers such as unmanned aerial vehicles (UAVs), robots or drones, the mobile camera **100** may be provided with multiple cameras mounted around a 360-degree arrangement and top and bottom placements so that the multiple cameras can provide a complete view of an environment. For example, if the mobile camera **100** is mounted on a drone, it may have six cameras mounted at a front position, a back position, a left position, a right position, a top position, and a bottom position. In some examples, a single or multiple low-resolution and/or low-power cameras can be connected to the mobile camera **100** through a length of cable for use in applications that require inserting, feeding, or telescoping a camera through an aperture or passageway that is inaccessible by the mobile camera **100** in its entirety. Such an example application is a medical application in which a doctor needs to feed cameras into the body of a patient for further investigation, diagnosis, and/or surgery.

The example IMU **104** of FIGS. **1A** and **1B** is an electronic device that measures and reports movements in three-dimensional (3D) space associated with a carrier (e.g., a person, object, drone, UAV, vehicle, etc.) of the mobile camera **100** such as force, angular rate, and/or surrounding magnetic field. To measure such movements, the example IMU **104** may be in circuit with one or more motion sensors **158** (FIG. **1B**) such as one or more accelerometers, one or more gyroscopes, one or more magnetometers, etc. The example AC **106** can be used to detect ambient sounds including speech generated by a person carrying the mobile camera **100** and/or generated by persons in proximity to the mobile camera **100**. To detect such sounds, the AC **106** may be in circuit with one or more microphones **162** (FIG. **1B**). In other examples, other sensor interfaces may be provided to monitor for other environmental characteristics. For example, the mobile camera **100** may additionally or alternatively be provided with a temperature sensor interface, a pressure sensor interface, a humidity sensor interface, a radiation sensor interface, a wind sensor interface, a period movement sensor interface, an abrupt movement sensor interface, an air quality sensor interface, a particulates sensor interface, a pH sensor interface, etc. The example mobile camera **100** may be provided with any suitable sensors to measure or monitor any environmental characteristics in home, commercial, and/or industrial environments.

The example VPU **108** is provided to perform computer vision processing to provide visual awareness of surrounding environments. The example VPU **108** also includes capabilities to perform motion processing and/or audio processing to provide motion awareness and/or audio awareness. For example, the VPU **108** may interface with multiple sensors or sensor interfaces, including the cameras **102**, the IMU **104**, the motion sensors **158**, the AC **106**, and/or the microphone **162** to receive multiple sensor input data. The example VPU **108** of FIG. **1A** is provided with one or more convolutional neural network (CNN) feature analyzers **114**, one or more computer vision (CV) analyzers **116**, and/or one or more audio digital signal processors (DSPs) **118** to process such sensor input data as described below in connection with FIGS. **5A** and **5B**. In this manner, the example VPU **108** can perform visual processing, motion processing, audio processing, etc. on the sensor input data from the various sensors to provide visual awareness, motion awareness, and/or audio awareness. The VPU **108** of the illustrated example may be implemented using a VPU from the Myriad™ X family of VPUs and/or the Myriad™ 2 family of VPUs designed and sold by Movidius™, a company of

Intel Corporation. Alternatively, the example VPU **108** may be implemented using any other suitable VPU.

In the illustrated example, the VPU **108** processes pixel data from the cameras **102**, motion data from the IMU **104**, and/or audio data from the AC **106**, and generates sensor-based metadata describing such sensor data. By generating such sensor-based metadata, the mobile camera **100** can communicate the sensor-based metadata to a host device (e.g., a mobile phone **202** of FIG. **2**) and/or a cloud service (e.g., provided by the cloud system **206** of FIG. **2**) for processing instead of communicating the raw sensor data (e.g., the pixel data, the audio data, and/or the motion data). In this manner, in terms of visual captures, identities or privacies of individuals and/or private/personal property appearing in visual captures are not inadvertently exposed to other networked devices or computers connected to the Internet that may maliciously or inadvertently access such visual captures during transmission across the Internet. Such privacy protection associated with transmitting metadata instead of raw visual captures is useful to provide mobile cameras that comply with government and/or industry regulations regarding privacy protections of personal information. An example of such a government regulation of which compliance can be facilitated using examples disclosed herein is the European Union (EU) General Data Protection Regulation (GDPR), which is designed to harmonize data privacy laws across Europe, to protect and empower all EU citizens regarding data privacy, and to reshape the way organizations across the EU region approach data privacy. In addition, sending small-sized metadata, which can be encrypted and coded for additional security, significantly reduces power consumption that would otherwise be needed for transmitting the raw sensor data.

In some examples, mobile cameras disclosed herein may operate in an image/video output mode in which the mobile cameras output visual captures for storing at a host device and/or at a cloud service. In this manner, users may use the mobile camera **100** to generate picture and/or video memories for long-term storage and subsequent viewing by them and/or others that have been granted access privileges. Example mobile cameras disclosed herein may be provided with a user-controllable or system-controllable setting to set when a mobile camera is to operate in a metadata output mode or in an image/video output mode.

The example wireless communication interface **110** of FIGS. **1A** and **1B** may be implemented using any suitable wireless communication protocol such as the Wi-Fi wireless communication protocol, the Bluetooth® wireless communication protocol, the Zigbee® wireless communication protocol, etc. The wireless communication interface **110** may be used to communicate with a host device (e.g., one of the mobile phone host devices **202** of FIG. **2**) and/or other mobile cameras via client/server communications and/or peer-to-peer communications.

FIG. **2** illustrates example mobile phone host devices **202** in wireless communication with corresponding example mobile cameras **204** and an example cloud system **206**. In the illustrated example of FIG. **2**, the mobile phone host devices **202** serve as host devices to receive information from and send information to the example mobile cameras **204**. The mobile phone host devices **202** also communicatively connect the mobile cameras **204** to a cloud service provided by the cloud system **206**. Although the host devices **202** are shown as mobile phones, in other examples host devices **202** may be implemented using any other type of computing device including smartwatch or other wearable computing devices, tablet computing devices, laptop com-

puting devices, desktop computing devices, Internet appliances, Internet of Things (IoT) devices, etc. The example mobile cameras **204** are substantially similar or identical to the mobile camera **100** of FIGS. 1A and 1B.

In the illustrated example of FIG. 2, the mobile cameras **204** wirelessly communicate with their corresponding mobile phone host devices **202** using wireless communications **208** via wireless communication interfaces such as the wireless communication interface **110** of FIGS. 1A and 1B. In addition, the example mobile phone host devices **202** communicate wirelessly with the cloud system **206** via, for example, a cellular network, a Wi-Fi, or any other suitable wireless communication means. In any case, the mobile phone host devices **202** and the cloud system **206** communicate via a public network such as the Internet and/or via a private network. In some examples, the mobile cameras **204** may be configured to communicate directly with the cloud system **206** without an intervening host device **202**. In yet other examples, a host device **202** may be combined with a mobile camera **204** in a same device or housing.

The example cloud system **206** is implemented using a plurality of distributed computing nodes and/or storage nodes in communication with one another and/or with server hosts via a cloud-based network infrastructure. The example cloud system **206** provides cloud services to be accessed by the mobile phone host devices **202** and/or the mobile cameras **204**. Example cloud services may include metadata processing and information retrieval services to analyze and recognize metadata generated by the mobile cameras **204** and/or the mobile phone host devices **202**, and retrieve information from storage devices corresponding to the metadata. The cloud system **206** can communicate such retrieved information to the mobile phone host devices **202** for use by the mobile phone host devices **202** and/or the mobile cameras **204** and/or for viewing by users of the mobile phone host devices **202**. Example cloud services may additionally or alternatively include image storage and/or video storage services to store visual captures from the mobile cameras **204**. In some examples, the cloud system **206** may be replaced by a server-based system and/or any other network-based system in which the mobile phone host devices **202** communicate with central computing and/or storage devices of the network-based system.

The example mobile cameras **204** and the mobile phone host devices **202** are logically located at an edge of a network since they are the endpoints of data communications. In the illustrated example, sensor-based metadata and/or visual captures from the mobile cameras **204** may be stored and/or processed at the edge of the network (e.g., by the mobile cameras **204** and/or by the corresponding mobile phone host devices **202**) and/or at the cloud system **206**. Processing visual captures at the edge of the network instead of at the cloud system **206** offloads processing requirements from the cloud system **206**. For example, processing requirements for computer vision analyses are distributed across multiple mobile cameras **204** and/or mobile phone host devices **202** so that each mobile camera **204** and/or mobile phone host device **202** can use its processing capabilities for computer vision analyses of visual captures and generate metadata so that the cloud system **206** need not be equipped with the significant additional CPU (central processing unit) resources, GPU (graphic processing unit) resources, and/or memory resources required to perform such computer vision analyses for a large number of visual captures received from a large number of networked mobile cameras **204**. In addition, computer vision analyses can be done faster when

performed in parallel at distributed mobile cameras **204** rather than performed in seriatim in a central location such as the cloud system **206**.

In some examples, the mobile cameras **204** are concurrently used in different environments and communicate sensor-based metadata and/or visual captures to the cloud system **206** based on those different environments. In other examples, two or more of the mobile cameras **204** operate in a same environment such that they can produce visual captures from different perspectives or different fields of view of the same environment. In such examples, the visual captures from the different mobile cameras **204**, when considered in the aggregate, form a panoramic view of the environment or form an otherwise more expansive view of the environment than can be covered by any single one of the visual captures from a single mobile camera **204**. In yet other examples, a single mobile camera **204** is provided with multiple cameras as described above in connection with FIGS. 1A and 1B to provide a panoramic or more expansive view of its environment.

In the illustrated example, each mobile camera **204** is physically separate from its corresponding mobile phone host device **202** so that the mobile camera **204** can be worn by a person while the mobile phone host device **202** can be stowed away in a purse, a bag, and/or a pocket. This eliminates the need for a person using such a camera to pull out their mobile phone to capture images or video since such visual captures can be made by the mobile camera **204**. In addition, such arrangement is useful to assist people as they navigate throughout their different environments. For example, a person may be viewing their mobile phone while walking along a busy sidewalk. To prevent the person's distractedness from creating a dangerous situation, the mobile camera **204** may operate as another set of eyes to identify other upcoming people, vehicles, or other obstacles and warn the person of those surrounding elements. As such, example mobile cameras disclosed herein may operate as an "eyes always on the world" device to provide supplemental information to users about their surroundings. For example, a mobile camera **204** may perform computer vision analyses on a stream of visual captures as a person walks along the sidewalk to generate metadata identifying an approaching curb of the sidewalk by detecting a corresponding image feature such as an image of the curb, an edge of the curb, a line of the curb, etc. The mobile camera **204** may generate curb-warning metadata and communicate such metadata to a corresponding mobile phone host device **202** or other wearable device (e.g., smart glasses, an assistive device, etc.). The mobile phone host device **202** may handle the curb-warning metadata by emitting an audible warning and/or displaying a notification to the person indicating that the person should be cautious of the curb and/or an approaching vehicle beyond the curb. In some examples, stereoscopic images and/or video captured by the mobile camera **204** may be used to determine distances between the person and approaching obstacles (e.g., the vehicle or the curb) and/or speeds at which the person is becoming closer to the approaching obstacles. Such distance and/or speed information can be provided to the person via the person's mobile phone host device **202** or other computing device such as a wearable device.

In some examples, the mobile cameras **204** may be used to identify other people and/or other features of interest within visual proximity of the mobile cameras **204**. In such examples, the mobile cameras **204** may be worn on lapels, shirts or at some location on persons carrying the mobile cameras **204**. For example, a mobile camera **204** may be

worn by a person at a conference or tradeshow in which numerous other people are in attendance and at which numerous facilities (e.g., cafeteria, phone charging stations, conference rooms, restrooms, etc.) and/or vendor booths are available. The person may recognize another attendee but not remember the name of the attendee or other information about the attendee (e.g., name, title, employer, last meeting, last interaction, last communication, etc.). In such a situation, the mobile camera **204** proactively generates and analyzes visual captures of the other attendee, and communicates with a cloud service hosted by the cloud system **206** to obtain pertinent information about the other attendee for access by the person wearing the mobile camera **204**. This information about the attendee may be useful to refresh the person's memory about the attendee and/or to newly inform the person about the attendee so that the person may make a more informed and relevant introduction with the attendee. In some examples, the associated mobile phone host device **202** generates an alert (e.g., an audible alert, a vibrating alert, a display notification, etc.) notifying the person when the information about the attendee has been received from the cloud service. In this manner, the person need not expend effort and time to actively send requests for information. Instead, the mobile camera **204**, the mobile phone host device **202**, and the cloud system **206** operate without user intervention to provide such information.

In some examples, the cloud service provided by the cloud system **206** is a social network service (e.g., Facebook, Twitter, etc.) or a business network service (e.g., LinkedIn) having registered subscribers, profile information about those subscribers, calendar information about those subscribers, email and instant messaging information about those subscribers, etc. In this manner, when the cloud service receives sensor-based metadata and/or visual captures generated by the mobile cameras **204**, the cloud service can leverage such subscriber information to provide relevant information about the people represented in the sensor-based data and/or visual captures. In other examples, the cloud service communicates with other subscriber-model services such as social network service or business network services to access such subscriber information in accordance with permissions granted by those subscribers for providing access to their subscriber information.

In some examples, the mobile cameras **204** may also be used to recognize and access information about non-human objects. For example, the mobile cameras **204** may be used by patrons in an art museum to recognize different pieces of art, retrieve information (e.g., artwork name, artist name, creation date, creation place, etc.) about such art from the cloud service and access the retrieved information via the mobile phone host devices **202**.

In examples disclosed herein, the mobile phone host devices **202** are provided with example information brokers (IBs) **210** to transfer information between mobile cameras **204** and a cloud service provided by the cloud system **206**. In the illustrated example, the information brokers **210** are implemented using an MQTT (Message Queue Telemetry Transport) protocol. The MQTT protocol is an ISO standard (ISO/IEC PRF 20922) publish-subscribe-based messaging protocol that works on top of the TCP/IP protocol. In examples disclosed herein, the MQTT protocol can be used as a lightweight messaging protocol for small sensors (e.g., the mobile cameras **204**) and mobile devices (e.g., the mobile phone host devices **202**) to handle communications for high-latency and/or unreliable networks. In this manner, examples disclosed herein can employ the MQTT protocol as a low-power and low-bandwidth protocol to maintain

efficient and reliable communications between the mobile cameras **204** and the mobile phone host devices **202** using peer-to-peer (P2P) communications and/or for exchanging information such as metadata and/or visual captures with cloud services or other networked devices. Using the information brokers **210**, lightweight communications can be used to send lightweight data (e.g., metadata extracted by the mobile cameras **204** from visual captures) from the mobile cameras **204** and/or the mobile phone host devices **202** to a cloud service. In such examples, the mobile cameras **204** can process visual captures at the edge of a network and consume fewer amounts of network bandwidth to transfer resulting metadata to a cloud service.

FIG. 3 illustrates an example multiple power-level operating state hierarchy **300** for use with the mobile cameras **100**, **204** of FIGS. 1A, 1B, and 2. The example multiple power-level operating state hierarchy **300** can be used to enable low power usage for the mobile cameras **100**, **204** and, thus, conserve battery charge. The example multiple power-level operating state hierarchy **300** enables low power usage based on the premise that, much of the time, the example mobile cameras **100**, **204** are not performing compute-intensive processes and/or collecting high-quality visual captures. For example, in a low-power feature monitoring mode, a mobile camera **100**, **204** may monitor motion sensor data, audio sensor data and/or low-resolution visual captures (e.g., performing CNN inference processes) to identify trigger features that could cause the mobile camera **100**, **204** to transition to one or more higher power modes.

In some examples, the multiple power-level operating state hierarchy **300** can be used to control the power-on or active state of a wireless communication subsystem (e.g., the wireless communication interface **110** of FIGS. 1A and 1B) of a mobile camera **100**, **204**. For example, at lower power states of the multiple power-level operating state hierarchy **300**, the mobile camera **100**, **204** may refrain from generating metadata needing to be communicated to a cloud service provided by the cloud system **206**. In such scenarios, the wireless communication interface **110** can be kept in a low-power mode to conserve battery power.

The operating states of the example multiple power-level operating state hierarchy **300** include an example reset state **302**, an example motion feature detection state **304**, an example audio feature detection state **306**, an example low-resolution camera feature detection state **308**, an example computer vision processing feature detection state **310**, an example CNN feature detection state **312**, an example high-resolution camera feature detection state **314**, and an example video capture state **316**.

FIG. 4 illustrates an example power usage trend of the mobile camera **100**, **204** that depicts relative power usage between the different power states **302**, **304**, **306**, **308**, **310**, **312**, **314**, and **316**. In the illustrated example of FIG. 4, the lowest power state is the reset state **302**, and the highest power state is the video capture state **316**. As the mobile camera **100**, **204** progresses along the different power states **302**, **304**, **306**, **308**, **310**, **312**, **314**, and **316** from the reset state **302** to the video capture state **316**, processing resources and electrical current drawn by the subsystems of the mobile camera **100**, **204** increase which, in turn, increases power consumption.

In the example reset state **302**, much of the mobile camera **100**, **204** is in a low-power mode in which only a small amount of electrical power is used to power system-critical components such as a real-time clock to maintain system time, external interrupt inputs to respond to sensor-based wakeup events, a watchdog timer to schedule periodic or

aperiodic wakeup events, etc., while other subsystems are in a low-power standby mode. During wakeup events, the mobile camera **100, 204** may analyze input sensor data to identify trigger features that cause the mobile camera **100, 204** to transition to higher power states. In examples disclosed herein, trigger features that cause the mobile camera **100, 204** to transition between the different power states of the multiple power-level operating state hierarchy **300** may be detected by the IMU **104**, the AC **106**, and/or the VPU **108**, and/or may be detected by monitoring circuits provided in intelligent sensors that are in circuit with sensor interfaces of the IMU **104**, the AC **106**, and/or the VPU **108**. For example, small amounts of power (e.g., ~2 milliwatts) may be provided (e.g., periodically or aperiodically) to the IMU **104**, the AC **106**, and/or the VPU **108** to process sensor data from corresponding sensors to identify trigger features. Alternatively, small amounts of power (e.g., ~2 milliwatts) may be provided (e.g., periodically or aperiodically) to monitoring circuits in the intelligent sensors so that the monitoring circuits can analyze sensor data generated by the sensors to identify trigger features. In such examples, upon detecting trigger features, sensors may send external interrupts to corresponding sensor subsystems (e.g., the IMU **104**, the AC **106**, and/or the VPU **108**) to wake up the sensor subsystems and initiate transitions between the different power states of the multiple power-level operating state hierarchy **300**.

An example usage scenario of power state transitions involves a person wearing a mobile camera **100, 204**. When the person is inactive such as standing still, sitting, or sleeping, the mobile camera **100, 204** may enter the reset state **302** as a result of the mobile camera **100, 204** not detecting any motion associated with the person. However, when the person moves, the mobile camera **100, 204** may incrementally enter into higher power states (e.g., the motion feature detection state **304**, the audio feature detection state **306**, etc.) based on the amount of motion detected by the mobile camera **100, 204**. For example, a person may begin walking which causes the mobile camera **100, 204** to enter the audio feature detection state **306** and begin analyzing audio sensor data representative of surrounding speech, sound, noise, etc. and/or at some point the mobile camera **100, 204** may transition into the low-resolution camera feature detection state **308** to analyze low-resolution visual captures of surrounding areas. In the audio feature detection state **306**, the mobile camera **100, 204** may monitor for the presence of, for example, other people by recognizing speech. In the example low-resolution camera feature detection state **308**, the mobile camera **100, 204** may monitor for the presence of, for example, other people or other features of interest based on visual confirmations. In some examples, the mobile camera **100, 204** may skip one or more operating states to move to higher or lower power states along the multiple power-level operating state hierarchy **300**. For example, detecting a running motion in the motion feature detection state **304** may cause the mobile camera **100, 204** to transition from the motion feature detection state **304** to the low-resolution camera feature detection state **308** and/or to the video capture state **316**. In such an example, the low-resolution feature detection state **308** may be used to analyze images of distant objects that a person carrying the mobile camera **100, 204** may quickly approach due to the running activity. The low-resolution feature detection state **308** would be more suitable for detection than the audio feature detection state **306** due to the distance of far away objects and/or due to noisy wind, breathing, shoe, or friction sounds generated while running. The example video capture

state **316** may be activated during such detected running to record video for safety purposes and/or if the person has preconfigured the mobile camera **100, 204** to record runs for personal video purposes. When the running activity stops, the mobile camera **100, 204** may transition by skipping multiple operating states down the multiple power-level operating state hierarchy **300**, for example, from the video capture state **316** directly to the reset state **302**.

In the example multiple power-level operating state hierarchy **300** of FIG. 3, during wakeup events from the reset state **302**, the mobile camera **100, 204** can provide a small amount of electrical power to a motion sensor interface of the IMU **104** (FIG. 1A) to receive motion sensor data via one or more motion sensors of the mobile camera **100, 204**. In the motion feature detection state **304**, the example IMU **104** can measure or analyze the motion activity represented by the motion sensor data to identify a motion feature trigger. For example, a motion feature trigger could be a threshold amount of motion activity that causes the mobile camera **100, 204** to remain in the motion feature detection state **304** or transition to the audio feature detection state **306**. When the IMU **104** does not detect a certain amount of threshold motion activity during the motion feature detection state **304** to remain in the motion feature detection state **304** or to enter the audio feature detection state **306**, the mobile camera **100, 204** returns to the reset state **302**. In some examples, the mobile camera **100, 204** stays in the motion feature detection state **304** when the IMU **104** detects a first amount of threshold motion activity and enters the audio feature detection state **306** when the IMU **104** detects a second amount of threshold motion activity. For example, the first amount of threshold motion activity could be sufficient activity that warrants staying in the motion feature detection state **304** to continue monitoring motion activity that could lead to satisfying the second amount of threshold motion activity to transition to the audio feature detection state **306**. The amounts of threshold motion activity may be magnitudes of motion and/or durations of motion.

In the example audio feature detection state **306**, the mobile camera **100, 204** provides power to the audio codec **106** to receive audio sensor data from, for example, a microphone. In this manner, the mobile camera **100, 204** can analyze the audio sensor data to identify audio feature triggers (e.g., speech, sound, noise, a dog bark, a cat meow, a door opening, a door closing, a car engine sound, etc.). In some examples, an audio feature trigger is based on a rate of change in an audio signal (e.g., an abrupt sound feature). In some examples in which the mobile camera **100, 204** monitors for the presence of people, when the mobile camera **100, 204** identifies particular speech (e.g., words and/or phrases based on speech recognition) and/or identifies a particular speaker (e.g., based on speaker recognition), the mobile camera **100, 204** transitions to the low-resolution camera feature detection state **308**.

In the example low-resolution camera feature detection state **308**, the mobile camera **100, 204** powers a camera interface of the VPU **108** (FIGS. 1A and 1B) to receive low-resolution visual captures from a low-resolution camera **102a,b** (FIGS. 1A and 1B). In some examples, the low-resolution camera **102a,b** is provided with motion detection capabilities. In this manner, the VPU **108** may remain in a low-power state until the low-resolution camera **102a,b** detects a threshold amount of visual motion (e.g., a visual feature trigger) that warrants notifying the VPU **108** to transition into a higher power operating state. Detecting sufficient visual motion may be based on whether there is sufficient lighting for capturing images having sufficient

visibility of the surroundings to be adequately processed by the VPU 108. In such examples, when lighting is low, the mobile camera 100, 204 may remain in the low-resolution camera feature detection state 308 or return to the audio feature detection state 306. As such, the mobile camera 100, 204 can conserve battery power by limiting power to the VPU 108 until a visual feature trigger is detected by the low-resolution camera 102a,b.

When the example low-resolution camera 102a,b detects a visual feature trigger, the mobile camera 100, 204 may transition into the computer vision processing feature detection state 310. In the computer vision processing feature detection state 310, the VPU 108 may analyze visual captures from the low-resolution camera 102a,b to detect whether a person is within visual proximity of the low-resolution camera 102a,b. When a face feature in a visual capture from the low-resolution camera 102a,b satisfies a face feature threshold, the mobile camera 100, 204 transitions to the CNN feature detection state 312. In the example CNN feature detection state 312, an example CNN feature analyzer 114 (FIG. 1A) of the VPU 108 performs computer vision analyses on the detected face. The example CNN feature analyzer 114 may compare the detected face to a database or dictionary of reference face images or reference face metadata stored locally in the mobile camera 100, 204 and/or in a corresponding mobile phone host device 202 (FIG. 2). If the CNN feature analyzer 114 determines that the detected face matches one of the reference face images, the mobile camera 100, 204 may access a service 318 (e.g., via the cloud system 206 of FIG. 2) to obtain information about the person corresponding to the detected face. Additionally or alternatively, the mobile camera 100, 204 may transition to the example high-resolution camera feature detection state 314 to capture a still image of the person corresponding to the detected face and/or may transition to the example video capture state 316 to capture video of the person corresponding to the detected face.

In the illustrated example of FIG. 3, transitioning between the different states of the multiple power-level operating state hierarchy 300 may be based on policies or rules stored in the mobile cameras 100, 204 and/or stored in corresponding mobile phone host devices 202 (FIG. 2) for access by the mobile cameras 100, 204. In some examples, the policies for transitioning between the different operating states cause the mobile camera 100, 204 to remain in the reset state 302 or relatively lower power operating states (e.g., the motion feature detection state 304, the audio feature detection state 306, the low-resolution camera feature detection state 308) for a majority of the time such that the mobile camera 100, 204 consumes relatively little power. The mobile camera 100, 204 can then transition, from time to time, to operating states that contribute to relatively higher power consumption only when necessary to collect high-resolution visual captures and/or to access an external service via wireless communications. By transitioning to such higher power operating states for only short durations, examples disclosed herein enable keeping higher power consumption subsystems (e.g., the high-resolution cameras 102c,d of FIGS. 1A and 1B and the wireless communication interface 110 of FIGS. 1A and 1B) off most of the time until needing to be used in such higher power operating states. In this manner, the mobile camera 100, 204 can be used for a relatively long time (e.g., days or weeks) between battery charges or battery replacements.

In some examples, the different states of FIG. 3 are used by the mobile camera 100, 204 to modulate its operation between the different operating states based on remaining

battery power and desired minutes of remaining operation. For example, the mobile camera 100, 204 enters a battery-critical mode and operates at lower power states (e.g., the motion feature detection state 304, the audio feature detection state 306, the low-resolution camera feature detection state 308) without entering higher power states when the remaining battery charge of the mobile camera 100, 204 is low and a desired duration of remaining operation requires less power usage than possible in the higher power states. In this manner, the mobile camera 100, 204 can continue monitoring its surroundings for features of interest and can continue to collect and store the occurrences of such features of interest without entering the higher power states. For example, in the battery-critical mode, the mobile camera 100, 204 could define the low-resolution camera feature detection state 308 as a maximum state and use the low-resolution camera feature detection state 308 to collect visual captures instead of transitioning into the high-resolution camera feature detection state 314.

In the battery-critical mode, policies for transitioning between the different operating states of FIG. 3 may also be adapted so that the mobile camera 100, 204 operates in a more power-conservative manner. For example, when the mobile camera 100, 204 is not in the battery-critical mode, a policy for transitioning from the motion feature detection state 304 to the audio feature detection state 306 may be that the IMU 104 must detect any motion in any direction, while when operating in the battery-critical mode, the policy for transitioning from the motion feature detection state 304 to the audio feature detection state 306 may change to require, for example, a detected change in direction of 90 degrees, 180 degrees, etc. In this manner, to further conserve power during the battery-critical mode, the mobile camera 100, 204 can remain in lower power states unless it detects feature triggers that are relatively more significant than would be required when not operating in the battery-critical mode.

Although the different operating states of the example multiple power-level operating state hierarchy 300 of FIG. 3 are shown in a particular order, policies for transitioning between the different operating states may define different orders for transitions between the different operating states. For example, a small amount of movement detected by the IMU 104 may satisfy a low-movement feature detection threshold to transition from the motion feature detection state 304 to the audio feature detection state 306, while a more significant amount of movement detected by the IMU 104 may satisfy a high-movement feature detection threshold to transition from the motion feature detection state 304 to the low-resolution camera feature detection state 308. In addition, although the example multiple power-level operating state hierarchy 300 of FIG. 3 shows a transition from the reset state 302 to the motion feature detection state 304 during wakeup events, a different wakeup policy may instead be applied to transition the mobile camera 100, 204 from the reset state 302 to the audio feature detection state 306 during such wakeup events and/or to transition from the reset state 302 to both the motion feature detection state 304 and the audio feature detection state 306 simultaneously. Similarly, in other examples, the mobile camera 100, 204 may be provided with policies that define transitions from one operating state to multiple operating states simultaneously and/or from multiple operating states in which the mobile camera 100, 204 is simultaneously operating to a single operating state. Policies for controlling operating states and/or transitions between the operating states may be user defined (e.g., via the mobile phone host devices 202 of

FIG. 2) and/or system defined (e.g., programmed and/or stored in a configuration file by a developer or manufacturer).

In addition, the example multiple power-level operating state hierarchy 300 of FIG. 3 may be modified to include fewer or more and/or different operating states than those illustrated in FIG. 3. In some examples, the operating states and activations of corresponding sensors are rearranged in the multiple power-level operating state hierarchy 300 so that transitions along the multiple power-level operating state hierarchy 300 cause a different sequence of activations of the corresponding sensors. For example, the low-resolution camera feature detection state 308, the high-resolution camera feature detection state 314, and the example video capture state 316 may be rearranged so that the ordering in which each of those states is activated along the multiple power-level operating state hierarchy 300 is different. For example, one or more of the high-resolution cameras 102c,d may be activated during the high-resolution camera feature detection state 314 before activating the low-resolution cameras 102a-b during the low-resolution camera feature detection state 308. In some examples, the ordering of the operating states of the multiple power-level operating state hierarchy 300 is static and unchangeable. In other examples, the ordering of the operating states of the multiple power-level operating state hierarchy 300 is dynamic so that it may be changed using, for example, policy definitions.

FIGS. 5A and 5B depict an example block diagram of the VPU 108 of FIGS. 1A and 1B that may be used to implement the mobile cameras 100, 204 of FIGS. 1A, 1B, and 2 to operate at the different power-level operating states of the example multiple power-level operating state hierarchy 300 of FIG. 3. The illustrated example of FIG. 5A shows the low-resolution camera 102a, the IMU 104, the audio codec 106, and the high-resolution camera 102c in circuit with the VPU 108. To perform motion analysis, audio analysis and computer vision analysis, the example VPU 108 is provided with a number of example CNN feature analyzers (e.g., that are represented in FIG. 1A as the CNN feature analyzers 114) as described below. The example CNN feature analyzers are implemented using convolutional neural networks that can be trained to detect or recognize different features (e.g., motion, audio, speech, words, persons, faces, objects, etc.) in sensor data (e.g., motion data, audio data, visual captures, etc.) provided by the IMU 104, the audio codec 106, and the cameras 102a-d. For example, the example CNN feature analyzers are trained to detect or recognize features in the sensor data by motion analysis algorithms, audio analysis algorithms, computer vision algorithms (e.g., the CV algorithms 116 of FIG. 1A) to generate probabilities representative of likelihoods that different features in the sensor data can be confirmed. In this manner, the example CNN feature analyzers can generate confirmations for presences of features of interest based on probabilities of those features satisfying feature probability thresholds.

To perform motion analysis during the motion feature detection state 304 (FIG. 3), the example VPU 108 is provided with an example motion feature detector 502 that is in circuit with the IMU 104, and an example CNN motion activity recognizer 504 that is in circuit with the motion feature detector 502. The example motion feature detector 502 is provided to detect motion activity of the mobile camera 100, 204 by receiving motion sensor data from the IMU 104, and performing motion feature detection analysis on the motion sensor data to detect movement of the mobile camera 100, 204. In the illustrated example, the example motion feature detector 502 is implemented by the DSP 118

of FIG. 1A, and the motion sensor data is raw motion sensor data representative of magnitudes and directions of motion or movement detected by the motion sensor(s) 158 (FIG. 1B) that are in circuit with the IMU 104. When the example motion feature detector 502 detects motion having sufficient magnitude and/or sufficient duration to satisfy a motion feature trigger threshold, the motion feature detector 502 sends a motion detection confirmation to the CNN motion activity recognizer 504. In addition, the motion detection confirmation causes the VPU 108 to transition to a next higher power operating state (e.g., the audio feature detection state 306 of FIGS. 3 and 4).

The example CNN motion activity recognizer 504 analyzes the motion sensor data to identify particular motion-based activity types that the CNN motion activity recognizer 504 is trained to recognize. Example motion-based activity types that may be trained into the CNN motion activity recognizer 504 include running, jumping, climbing stairs, skipping, at rest, riding in car, riding in train, etc. The example CNN motion activity recognizer 504 outputs corresponding motion metadata for different recognized activity types shown in the example of FIG. 5A as activity (1) through activity (n). In the illustrated example, the motion metadata is generated by the CNN motion activity recognizer 504 to describe the types of motion recognized in the motion sensor data (e.g., running, jumping, climbing stairs, skipping, at rest, riding in car, riding in train, etc.). In the illustrated example, the CNN motion activity recognizer 504 generates the motion metadata by accessing the metadata from a local reference motion metadata library or reference motion metadata database that stores metadata terms in association with corresponding reference motion feature definitions. To retrieve motion metadata, the CNN motion activity recognizer 504 can compare motion features from the motion sensor data with the reference motion feature definitions in the local reference motion metadata library or database. In some examples, an extended reference motion metadata library or reference motion metadata database may be stored at the cloud system 206, and accessed by the CNN motion activity recognizer 504 using an application programming interface (API) for such cloud-based library or database. The example recognized activity (1) through activity (n) cause the VPU 108 to transition to a fully awake state. In the illustrated example, a motion activity multiplexer 506 receives the motion metadata for the recognized activity (1) through activity (n), and provides the motion metadata as generally indicated by reference numeral 508 to an example full wake-up event multiplexer 510.

To perform audio analysis during the audio feature detection state 306 (FIG. 3), the example VPU 108 is provided with an example audio feature detector 514 that is in circuit with the audio codec 106, an example voice activity detector 516 that is in circuit with the audio feature detector 514, an example CNN wake-up word recognizer 518 that is in circuit with the voice activity detector 516, and an example CNN command word recognizer 520 that is in circuit with the CNN wake-up word recognizer 518. The example audio feature detector 514 is provided to detect audio activity near the mobile camera 100, 204 by receiving audio sensor data from the audio codec 106, and performing audio feature detection analysis on the audio sensor data. In the illustrated example, the example audio feature detector 514 is implemented by the DSP 118 of FIG. 1A, and the audio sensor data is raw audio waveform data representative of audio sensed by the microphone 162 (FIG. 1B) that is in circuit with the audio codec 106. When the example audio feature detector 514 detects audio having sufficient amplitude and/

or sufficient duration to satisfy an audio feature trigger threshold, the audio feature detector **514** sends a sound detection confirmation to the voice activity detector **516**. In some examples, the feature trigger threshold is satisfied when the audio feature detector **514** detects a particular rate of change in an audio signal (e.g., an abrupt sound feature). The sound detection confirmation confirms the presence of sounds in the audio sensor data that should be further analyzed by the VPU **108**. In the illustrated example, the sounds may be any sound or noise such as voices, handclaps, animal sounds, car horns, gunshots, etc. The example voice activity detector **516** analyzes the audio sensor data using voice feature detection analysis to determine whether any portion of it is representative of a person's voice. For example, the audio sensor data may be an audio sampling of ambient noise or sounds that are not a person's voice and/or may be an audio sampling of a person's voice with or without background noise or sounds. In any case, the example voice activity detector **516** sends a confirmation of voice detection to the CNN wake-up word recognizer **518** when a voice is detected.

The example CNN wake-up word recognizer **518** analyzes the audio sensor data to identify particular wake-up words that the CNN wake-up word recognizer **518** is trained to recognize based on speech recognition algorithms. Example wake-up words that may be trained into the CNN wake-up word recognizer **518** include persons names, home, car, outside, inside, please, want, listen, wake-up, record, capture, video, hello, hi, camera-on, camera-off, help, etc. In some examples, wake-up phrases may also be defined. The example CNN wake-up word recognizer **518** sends a wake-up word detection confirmation to the CNN command word recognizer **520** when a wake-up word is detected.

In the illustrated example, the CNN wake-up word recognizer **518** also generates audio metadata corresponding to the analyzed audio sensor data. Such audio metadata may be a name of a speaker, an age of a speaker, a gender of a speaker, type of command spoken, etc. In the illustrated example, the CNN wake-up word recognizer **518** generates the audio metadata by accessing the metadata from a local reference audio metadata library or reference audio metadata database that stores metadata terms in association with corresponding reference audio feature definitions. To retrieve audio metadata, the CNN wake-up word recognizer **518** can compare audio features from the audio sensor data with the reference audio feature definitions in the local reference audio metadata library or database. In some examples, an extended reference audio metadata library or reference audio metadata database may be stored at the cloud system **206**, and accessed by the CNN wake-up word recognizer **518** using an API for such cloud-based library or database.

The example CNN command word recognizer **520** analyzes the audio sensor data to identify particular command words that the CNN command word recognizer **520** is trained to recognize based on speech recognition algorithms. In the illustrated example, command words are a subset of wake-up words such that the wake-up words cause the mobile cameras **100**, **204** to transition to a higher power operating state (e.g., the low-resolution camera feature detection state **308** of FIGS. **3** and **4**), but only a subset of the wake-up words also defined as command words that cause the mobile cameras **100**, **204** to transition to a fully awake state and/or perform corresponding operations. Example command words that may be trained into the CNN command word recognizer **520** include wake-up, record, capture, camera-on, camera-off, help, etc. The example

CNN command word recognizer **520** outputs corresponding audio metadata for different recognized command words shown in the example of FIG. **5A** as command (1) through command (n). In the illustrated example, a command word multiplexer **522** receives the audio metadata for the recognized command (1) through command (n), and provides the audio metadata as generally indicated by reference numeral **524** to the example full wake-up event multiplexer **510**.

To perform low-resolution image analysis during the low-resolution camera feature detection state **308** (FIG. **3**), the example VPU **108** is provided with an example image feature detector **528** that is in circuit with the low-resolution camera **102a**, an example CNN face detector **530** that is in circuit with the image feature detector **528**, an example CNN wake-up face recognizer **532** that is in circuit with the CNN face detector **530**, and an example CNN face recognizer **534** that is in circuit with the CNN wake-up face recognizer **532**. The example image feature detector **528** is provided to detect visible activity near the mobile camera **100**, **204** by receiving low-resolution visual captures from the low-resolution camera **102a**, and performing image feature detection analyses on the low-resolution visual captures. In the illustrated example, the example image feature detector **528** is implemented by the DSP **118** of FIG. **1A**, and the visual captures are in the form of pixel data (e.g., multi-bit color pixel data or multi-bit black and white pixel data). In some examples, the low-resolution camera **102a** only provides visual capture data to the image feature detector **528** when the low-resolution camera **102a** has performed a pre-processing feature detection process to identify whether a region of interest (RoI) event is detected. Such a RoI event may occur when there is sufficient lighting in a visual capture to discern a visibly detectable feature in the visual capture (e.g., more than just a fully saturated dark image).

When the example image feature detector **528** receives a visual capture from the low-resolution camera **102a** and detects a visual feature having sufficient visual definition and/or sufficient duration to satisfy a visual feature trigger threshold, the image feature detector **528** sends an image detection confirmation to the CNN face detector **530**. The image detection confirmation confirms the presence of a sufficiently visual feature in the low-resolution visual capture that should be further analyzed by the VPU **108**. In the illustrated example, the visual features may be any visual feature of interest such as objects, people, vehicles, license plates, signs, etc. The example CNN face detector **530** analyzes the low-resolution visual capture using face feature detection analysis to determine whether any portion of it is representative of a face. For example, the low-resolution visual capture may include visual features that are not a person's face and/or may visual feature representative of a person's face with or without other visual features. In any case, the example CNN face detector **530** sends a confirmation of face detection to the CNN wake-up face recognizer **532** when a face is detected.

The example CNN wake-up face recognizer **532** analyzes the low-resolution visual capture to identify particular wake-up faces that the CNN wake-up face recognizer **532** is trained to recognize based on computer vision algorithms (e.g., the computer vision algorithms **116** of FIG. **1A**). Example wake-up faces that may be trained into the CNN wake-up face recognizer **532** may be stored into a local reference face metadata library or reference face metadata database that stores metadata in association with corresponding reference face images or corresponding reference feature vectors of faces. The CNN wake-up face recognizer **532** may confirm a presence of a face of interest in the

low-resolution visual capture by comparing the pixel-based image or feature vectors of the face in the low-resolution visual capture to reference visual feature definitions (e.g., reference face images or reference feature vectors) in the local reference image metadata library or database. In some examples, an extended reference image metadata library or reference image metadata database may be stored at the cloud system 206, and accessed by the CNN wake-up face recognizer 532 using an API for such cloud-based library or database. The example CNN wake-up face recognizer 532 sends a wake-up face detection confirmation to the CNN face recognizer 534 when a wake-up face is detected. In the illustrated example, the CNN wake-up face recognizer 532 also uses the local reference image metadata library or database and/or from the extended reference image metadata library or database at the cloud system 206 to generate face metadata corresponding to detected faces. Such face metadata may be name of a person, age of a person, gender of a person, etc.

The example CNN face recognizer 534 analyzes the visual capture to identify particular faces that the CNN face recognizer 534 is trained to recognize based on the computer vision algorithms 116. Recognition of such particular faces causes the mobile camera 100, 204 to transition to a fully awake state. In the illustrated example, faces recognized by the CNN wake-up face recognizer 532 and the CNN face recognizer 534 are a subset of faces detected by the CNN face detector 530 such that the faces detected by the CNN face detector 530 cause the mobile cameras 100, 204 to transition to a higher power operating state (e.g., the high-resolution camera feature detection state 314 of FIGS. 3 and 4), but only a subset of the detected faces cause the mobile cameras 100, 204 to transition to a fully awake state. The example CNN face recognizer 534 outputs corresponding face metadata for different recognized faces shown in the example of FIG. 5A as face (1) through face (n). In the illustrated example, a recognized face multiplexer 536 receives the face metadata for the recognized face (1) through face (n), and provides the face metadata as generally indicated by reference numeral 538 to the example full wake-up event multiplexer 510.

To perform high-resolution image analysis, the example VPU 108 is provided with an example CNN object recognizer 542 that is in circuit with the high-resolution camera 102c. The example CNN object recognizer 542 is provided to recognize objects near the mobile camera 100, 204 by analyzing high-resolution visual captures from the high-resolution camera 102c to identify particular objects that the CNN object recognizer 542 is trained to recognize based on the computer vision algorithms 116. Recognition of such objects causes the mobile camera 100, 204 to transition to a fully awake state. In the illustrated example, the CNN object recognizer 542 generates object metadata by accessing the metadata from a local reference object metadata library or reference object metadata database that stores metadata terms in association with corresponding reference object feature definitions. Example object metadata includes class of object (e.g., person, animal, natural feature, building, vehicle, etc.), vehicle (e.g., type, make, model, color, etc.), license plate (e.g., registered state, license plate number, etc.), etc. To retrieve object metadata, the CNN object recognizer 542 can compare object features from the high-resolution visual captures with the reference object feature definitions in the local reference object metadata library or database. In some examples, an extended reference object metadata library or reference object metadata database may be stored at the cloud system 206, and accessed by the CNN

object recognizer 542 using an API for such cloud-based library or database. The example CNN object recognizer 542 outputs corresponding object metadata for different recognized objects shown in the example of FIG. 5A as object (1) through object (n). In the illustrated example, a recognized object multiplexer 544 receives the object metadata for the recognized object (1) through object (n), and provides the object metadata as generally indicated by reference numeral 546 to the example full wake-up event multiplexer 510.

In the illustrated example of FIG. 5A, the VPU 108 is provided with trigger feature multiplexers 554 having event select lines 556 controllable by the VPU 108 to configure what metadata provided by the components of the VPU 108 as described above are to cause the mobile cameras 100, 204 to transition between different operating states of the example multiple power-level operating state hierarchy 300 of FIG. 3. For example, as shown in FIG. 5B, to provide metadata-based wakeup events to transition between different ones of the operating states, the VPU 108 is provided with an example power on reset (POR) state transitioner 562, an example always on (AoN) state transitioner 564, an example primary event state transitioner 566, an example secondary event state transitioner 568, an example tertiary event state transitioner 570, and an example fully active state transitioner 572. In the illustrated example, the power on reset state transitioner 562 generates a wakeup event to transition the mobile camera 100, 204 out of the reset state 302 of FIGS. 3 and 4. The AoN state transitioner 564 of the illustrated example generates a wakeup event to transition the mobile cameras 100, 204 out of the low-resolution camera feature detection state 308 based on the low-resolution camera 102a (FIG. 5A) being supplied minimal electrical power to perform pre-processing feature detection processes to identify whether a region of interest (RoI) event is detected. The primary event state transitioner 566, the secondary event state transitioner 568, and the tertiary event state transitioner 570 generate wakeup events to transition the mobile camera 100, 204 between different ones of the motion feature detection state 304, the audio feature detection state 306, the low-resolution camera feature detection state 308, the computer vision processing feature detection state 310, the CNN feature detection state 312, the high-resolution camera feature detection state 314, and/or the video capture state 316 of FIGS. 3 and 4 based on different combinations of motion feature(s), audio feature(s), and/or visual feature(s) from the different components of the VPU 108 that are selected by the VPU 108 via the event select lines 556 of the trigger feature multiplexers 554. In some examples more or fewer event state transitioners may be provided to the VPU 108. In some examples, a separate state transitioner is provided for each one of the motion feature detection state 304, the audio feature detection state 306, the low-resolution camera feature detection state 308, the computer vision processing feature detection state 310, the CNN feature detection state 312, the high-resolution camera feature detection state 314, and the video capture state 316 of FIGS. 3 and 4.

In the illustrated example of FIG. 5A, the full wake-up event multiplexer 510 is provided with metadata select lines 576 that are configurable by the VPU 108 to select different combinations of input metadata corresponding to the recognized motion activity(ies), the recognized command word(s), the recognized face(s), and the recognized object(s) that are to cause the mobile cameras 100, 204 to transition to a fully awake state. For example, based on selections of the metadata select lines 576 and the input metadata to the example full wake-up event multiplexer 510, the full wake-

up event multiplexer **510** provides metadata output **550**. The metadata output **550** is provided to the fully active state transitioner **572** (FIG. **5B**) to cause the VPU **108** to fully awake the mobile camera **100, 204**. In the illustrated example, when in a fully awake state, the VPU **108** enables a communications subsystem and the wireless communication interface **110** (FIGS. **1A** and **1B**) to send the metadata output **550** (e.g., the metadata generally indicated by reference numerals **508, 524, 538, and/or 546**) to a corresponding mobile phone host device **202** and/or the cloud system **206** (FIG. **2**). The example metadata output **550** may include one or more of the metadata received at the full wake-up event multiplexer **510**. For example, based on the controlling of the metadata select lines **576** of the full wake-up event multiplexer **510**, the metadata output **550** may include one or more of the input metadata corresponding to the recognized motion activity(ies), the recognized command word(s), the recognized face(s), and/or the recognized object(s).

FIG. **5C** depicts an example state-order configurator **582** that may be used with the VPU **108** depicted in FIGS. **5A** and **5B** to configure the ordering of the different power-level operating states of the example multiple power-level operating state hierarchy **300** of FIG. **3**. The example state-order configurator **582** arranges and/or rearranges the operating states and activations of corresponding sensors in the multiple power-level operating state hierarchy **300** so that the example state transitioners **566, 668, 570, 572** cause different sequences of transitions between operating states and corresponding sensors along the multiple power-level operating state hierarchy **300**. For example, to implement such ordering of operating states, the state-order configurator **582** is provided with configurable logic circuits to direct different ones of the inputs from the trigger feature multiplexers **554** of FIG. **5A** to different ones of the example state transitioners **566, 668, 570, 572**. In some examples, the state-order configurator **582** reorders the order of the different power-level operating states of the example multiple power-level operating state hierarchy **300** based on the inputs from the trigger feature multiplexers **554**. For example, when a combination of events is detected within a short threshold duration, the state-order configurator **582** may control the paths between the trigger feature multiplexers **554** and the different ones of the example state transitioners **566, 668, 570, 572** to transition to a different power-level operating state than would be transitioned if such combination of events were not detected or if a different combination of events were detected. For example, in response to a detection of high-speed movement (e.g., driving a car) and a concurrent detection of a screeching sound (e.g., tires skidding), the state-order configurator **582** may control the paths between the trigger feature multiplexers **554** and the different ones of the example state transitioners **566, 668, 570, 572** to transition from the example motion feature detection state **304** to the example video capture state **316**. This may be useful to capture video of an imminent vehicular accident.

In the illustrated example, the state-order configurator **582** enables the ordering of the operating states of the multiple power-level operating state hierarchy **300** to be dynamically modified. In some examples, such modifications are on policy definitions. In such examples, or other examples, such modifications implemented using firmware, software, and/or control registers. In some examples, the state-order configurator **582** enables the mobile camera **100, 204** to skip

one or more operating states to move to higher or lower power states along the multiple power-level operating state hierarchy **300**.

While an example manner of implementing the mobile camera **100, 204** and the VPU **108** are illustrated in FIGS. **1A, 1B, 2, 5A, 5B, and 5C**, one or more of the elements, processes and/or devices illustrated in FIGS. **1A, 1B, 2, 5A, 5B, and 5C** may be combined, divided, re-arranged, omitted, eliminated and/or implemented in any other way. Further, the example CNN feature analyzers **114**, the example computer vision algorithms **116**, and/or the example digital signal processors **118** of FIG. **1A**, the example motion feature detector **502**, the example CNN motion activity recognizer **504**, the example motion activity multiplexer **506**, the example full wake-up event multiplexer **510**, the example audio feature detector **514**, the example voice activity detector **516**, the example CNN wake-up word recognizer **518**, the example CNN command word recognizer **520**, the example command word multiplexer **522**, the example image feature detector **528**, the example CNN face detector **530**, the example CNN wake-up face recognizer **532**, the example CNN face recognizer **534**, the example recognized face multiplexer **536**, the example CNN object recognizer **542**, and/or the example trigger feature multiplexers **554** of FIG. **5A**, the example POR state transitioner **562**, the example AoN state transitioner **564**, the example primary event state transitioner **566**, the example secondary event state transitioner **568**, the example tertiary event state transitioner **570**, and/or the example fully active state transitioner **572** of FIG. **5B**, and/or the example state-order configurator **582** of FIG. **5C**, and/or, more generally, the example mobile camera **100, 204** and/or VPU **108** may be implemented by hardware, software, firmware and/or any combination of hardware, software and/or firmware. Thus, for example, any of the example CNN feature analyzers **114**, the example computer vision algorithms **116**, and/or the example digital signal processors **118** of FIG. **1A**, the example motion feature detector **502**, the example CNN motion activity recognizer **504**, the example motion activity multiplexer **506**, the example full wake-up event multiplexer **510**, the example audio feature detector **514**, the example voice activity detector **516**, the example CNN wake-up word recognizer **518**, the example CNN command word recognizer **520**, the example command word multiplexer **522**, the example image feature detector **528**, the example CNN face detector **530**, the example CNN wake-up face recognizer **532**, the example CNN face recognizer **534**, the example recognized face multiplexer **536**, the example CNN object recognizer **542**, and/or the example trigger feature multiplexers **554** of FIG. **5A**, the example POR state transitioner **562**, the example AoN state transitioner **564**, the example primary event state transitioner **566**, the example secondary event state transitioner **568**, the example tertiary event state transitioner **570**, and/or the example fully active state transitioner **572** of FIG. **5B**, and/or the example state-order configurator **582** of FIG. **5C** and/or, more generally, the example mobile camera **100, 204** and/or VPU **108** could be implemented by one or more analog or digital circuit(s), logic circuits, programmable processor(s), programmable controller(s), graphics processing unit(s) (GPU(s)), digital signal processor(s) (DSP(s)), application specific integrated circuit(s) (ASIC(s)), programmable logic device(s) (PLD(s)) and/or field programmable logic device(s) (FPLD(s)). When reading any of the apparatus or system claims of this patent to cover a purely software and/or firmware implementation, at least one of the example CNN feature analyzers **114**, the example computer vision algorithms **116**, and/or the

example digital signal processors **118** of FIG. 1A, the example motion feature detector **502**, the example CNN motion activity recognizer **504**, the example motion activity multiplexer **506**, the example full wake-up event multiplexer **510**, the example audio feature detector **514**, the example voice activity detector **516**, the example CNN wake-up word recognizer **518**, the example CNN command word recognizer **520**, the example command word multiplexer **522**, the example image feature detector **528**, the example CNN face detector **530**, the example CNN wake-up face recognizer **532**, the example CNN face recognizer **534**, the example recognized face multiplexer **536**, the example CNN object recognizer **542**, and/or the example trigger feature multiplexers **554** of FIG. 5A, the example POR state transitioner **562**, the example AoN state transitioner **564**, the example primary event state transitioner **566**, the example secondary event state transitioner **568**, the example tertiary event state transitioner **570**, and/or the example fully active state transitioner **572** of FIG. 5B, and/or the example state-order configurator **582** of FIG. 5C is/are hereby expressly defined to include a non-transitory computer readable storage device or storage disk such as a memory, a digital versatile disk (DVD), a compact disk (CD), a Blu-ray disk, etc. including the software and/or firmware. Further still, the example mobile camera **100**, **204** and/or the VPU **108** may include one or more elements, processes and/or devices in addition to, or instead of, those illustrated in FIGS. 1A, 1B, 2, 5A, 5B, and 5C and/or may include more than one of any or all of the illustrated elements, processes and devices. As used herein, the phrase “in communication,” including variations thereof, encompasses direct communication and/or indirect communication through one or more intermediary components, and does not require direct physical (e.g., wired) communication and/or constant communication, but rather additionally includes selective communication at periodic intervals, scheduled intervals, aperiodic intervals, and/or one-time events.

In some examples disclosed herein, means for recognizing features in sensor data may be implemented using one or more of the CNN feature analyzers **114** of FIG. 1A, the example CNN motion activity recognizer **504**, the example CNN wake-up word recognizer **518**, the example CNN command word recognizer **520**, the example CNN wake-up face recognizer **532**, the example CNN face recognizer **534**, and/or the example CNN object recognizer **542** of FIG. 5A. In some examples disclosed herein, means for transitioning the mobile camera **100**, **204** between different feature detection states (e.g., the motion feature detection state **304**, the audio feature detection state **306**, the low-resolution camera feature detection state **308**, the computer vision processing feature detection state **310**, the CNN feature detection state **312**, the high-resolution camera feature detection state **314**, and/or the video capture state **316** of FIGS. 3 and 4) may be implemented using one or more of the example POR state transitioner **562**, the example AoN state transitioner **564**, the example primary event state transitioner **566**, the example secondary event state transitioner **568**, the example tertiary event state transitioner **570**, and/or the example fully active state transitioner **572** of FIG. 5B. In some examples disclosed herein, means for communicating may be implemented by the wireless communication interface **110** of FIGS. 1A and 1B and/or by the interface circuit **720** of FIG. 7. In some examples, means for detecting features may be implemented by one or more of the motion feature detector **502**, the audio feature detector **515**, and/or the image feature detector **528** of FIG. 5A. In some examples disclosed herein,

means for configuring operating state order may be implemented by the example state-order configurator **582** of FIG. 5C.

A flowchart representative of example hardware logic or machine-readable instructions for implementing the mobile camera **100**, **204** and/or the VPU **108** of FIGS. 1A, 1B, 2, 5A, 5B, and 5C is shown in FIG. 6. The machine-readable instructions may be a program or portion of a program for execution by a processor such as the VPU **108** and/or the processor **712** shown in the example processor platform **700** discussed below in connection with FIG. 7. The program may be embodied in software stored on a non-transitory computer readable storage medium such as a CD-ROM, a floppy disk, a hard drive, a DVD, a Blu-ray disk, or a memory associated with the processor **712**, but the entire program and/or parts thereof could alternatively be executed by a device other than the processor **712** and/or embodied in firmware or dedicated hardware. Further, although the example program is described with reference to the flowchart illustrated in FIG. 6, many other methods of implementing the example mobile camera **100**, **204** and/or the VPU **108** may alternatively be used. For example, the order of execution of the blocks may be changed, and/or some of the blocks described may be changed, eliminated, or combined. Additionally or alternatively, any or all of the blocks may be implemented by one or more hardware circuits (e.g., discrete and/or integrated analog and/or digital circuitry, an FPGA, an ASIC, a comparator, an operational-amplifier (op-amp), a logic circuit, etc.) structured to perform the corresponding operation without executing software or firmware.

As mentioned above, the example process of FIG. 6 may be implemented using executable instructions (e.g., computer and/or machine readable instructions) stored on a non-transitory computer and/or machine readable medium such as a hard disk drive, a flash memory, a read-only memory, a compact disk, a digital versatile disk, a cache, a random-access memory and/or any other storage device or storage disk in which information is stored for any duration (e.g., for extended time periods, permanently, for brief instances, for temporarily buffering, and/or for caching of the information). As used herein, the term non-transitory computer readable medium is expressly defined to include any type of computer readable storage device and/or storage disk and to exclude propagating signals and to exclude transmission media.

The terms “including” and “comprising” (and all forms and tenses thereof) are used herein to be open ended terms. Thus, whenever a claim employs any form of “include” or “comprise” (e.g., comprises, includes, comprising, including, having, etc.) as a preamble or within a claim recitation of any kind, it is to be understood that additional elements, terms, etc. may be present without falling outside the scope of the corresponding claim or recitation. As used herein, when the phrase “at least” is used as the transition term in, for example, a preamble of a claim, it is open-ended in the same manner as the term “comprising” and “including” are open ended. The term “and/or” when used, for example, in a form such as A, B, and/or C refers to any combination or subset of A, B, C such as (1) A alone, (2) B alone, (3) C alone, (4) A with B, (5) A with C, and (6) B with C.

Turning in detail to FIG. 6, the example program transitions the mobile camera **100**, **204** between first and second feature detection states. The feature detection states may be any of the operating states of the example multiple power-level operating state hierarchy **300** of FIG. 3. Thus, example operations represented in FIG. 6 may be performed by any

components of a mobile camera **100, 204** and/or the VPU **108** of FIGS. **1A, 1B, 5A, 5B,** and/or **5C** corresponding to the feature detection states for which the example program of FIG. **6** is used.

The program of FIG. **6** begins at block **602** at which the example VPU **108** (FIGS. **1A, 1B, 6A** and **6B**) accesses sensor data. For example, the sensor data may be motion sensor data, audio sensor data, and/or visual capture data obtained from the motion feature detector **502**, the audio feature detector **514**, and/or the image feature detector **528** of FIG. **5A**. The example VPU **108** determines whether a feature of interest has been detected in the sensor data (block **604**). In some examples, the motion feature detector **502** analyzes the sensor data for a motion feature having sufficient magnitude and/or sufficient duration to satisfy a motion feature trigger threshold. In some examples, the audio feature detector **514** analyzes the sensor data for an audio feature having sufficient amplitude and/or sufficient duration to satisfy an audio feature trigger threshold. In some examples, the image feature detector **528** analyzes the sensor data for a visual feature having sufficient visual definition and/or sufficient duration to satisfy a visual feature trigger threshold. If a feature of interest has not been detected at block **604**, control returns to block **602** to obtain further sensor data to analyze.

When the VPU **108** determines at block **604** that a feature of interest is detected in the sensor data, the example VPU **108** performs a feature recognition analysis on the sensor data (block **606**). In some examples, motion activity recognition is performed by the CNN motion activity recognizer **504** (FIG. **5A**). In some examples, word recognition is performed by the CNN wake-up word recognizer **518** and/or the CNN command word recognizer **520** (FIG. **5A**). In some examples, face recognition is performed by the CNN wake-up face recognizer **532** and/or the CNN face recognizer **534** (FIG. **5A**). The example VPU **108** generates corresponding metadata for a recognized feature in the sensor data (block **608**). In some examples, the CNN motion activity recognizer **504** generates motion metadata. In some examples, the CNN wake-up word recognizer **518** and/or the CNN command word recognizer **520** generate(s) audio metadata. In some examples, the CNN wake-up face recognizer **532** and/or the CNN face recognizer **534** generate(s) face metadata. The example VPU **108** determines whether to transition the mobile camera **100, 204** to another operating state (block **610**). For example, a state transitioner **562, 564, 566, 568, 570,** or **572** (FIG. **5B**) corresponding to a current operating state of the mobile camera **100, 204** may determine whether to transition the mobile camera **100, 204** to another operating state based on whether the feature of interest recognized at block **606** satisfies a threshold to warrant such state transition. If the example VPU **108** determines at block **610** to not transition the mobile camera **100, 204** to another operating state, control returns to block **602** to obtain further sensor data to analyze.

When the example VPU **108** determines at block **610** to transition the mobile camera **100, 204** to another operating state, the VPU **108** transitions the mobile camera **100, 204** from a current feature detection state to a next feature detection state (block **612**). For example, a state transitioner **562, 564, 566, 568, 570,** or **572** corresponding to a current operating state of the mobile camera **100, 204** transitions the mobile camera **100, 204** from a current feature detection state to a next feature detection state based on the feature of interest recognized at block **606**. In some examples, the next feature detection state contributes to relatively higher power consumption by the mobile camera **100, 204** than the current

feature detection state in which the mobile camera **100, 204** operates before the transition of block **612**. In some examples, the example state-order configurator **582** of FIG. **5C** contributes to the implementation of block **612** by controlling or configuring the ordering of the operating states between which the transition occurs at block **612**.

The example VPU **108** accesses sensor data (block **614**). For example, a feature detector **502, 514, 528** (FIG. **5A**) corresponding to the operating state into which the mobile camera **100, 204** transitioned to at block **612** obtains corresponding sensor data. In examples in which the VPU **108** transitions the mobile camera **100, 204** to the high-resolution camera feature detection state **314** and/or the video capture state **316**, the CNN object recognizer **542** obtains the sensor data at block **614**. The example VPU **108** determines whether a feature of interest has been detected in the sensor data (block **616**). For example, a feature detector **502, 514, 528** may perform a feature detection analysis at block **616** on the sensor data to determine if a feature of interest is present in the sensor data. In some examples involving sensor data that represents visual captures, the CNN face detector **530** of FIG. **5A** may perform a feature detection analysis on the sensor data at block **616** after the image feature detector **528** detects a visual feature of interest in the sensor data. In some examples involving sensor data that includes audio data, the voice activity detector **516** of FIG. **5A** may perform a feature detection analysis on the sensor data at block **616** after the audio feature detector **514** detects an audio feature of interest in the sensor data. If a feature of interest has not been detected at block **616**, control returns to block **614** to obtain further sensor data to analyze. In some examples, after a threshold duration of time or a threshold number of times that the VPU **108** does not detect a feature of interest in the sensor data at block **616**, the VPU **108** may transition the camera **100, 204** back to a previous operating state, and control returns to block **602**.

When the VPU **108** determines at block **616** that a feature of interest has been detected in the sensor data, the example VPU **108** performs a feature recognition analysis on the sensor data (block **618**). In the illustrated example, the feature recognition analysis is performed by a CNN recognizer **504, 518, 520, 532, 534,** and/or **542** of FIG. **5A** corresponding to the operating state in which the mobile camera **100, 204** is currently operating. The example VPU **108** generates corresponding metadata for a recognized feature in the sensor data (block **620**). The example VPU **108** determines whether to send collected information to an external destination (block **622**). For example, the VPU **108** can determine based on inputs to the full wake-up event multiplexer **510** (FIG. **5A**) whether to send the metadata generated at block **620** and/or block **608** as the metadata output **550** from the mobile camera **100, 204** to a corresponding mobile phone host device **202** (FIG. **2**), to another mobile camera **100, 204**, and/or to the cloud system **206** (FIG. **2**). In some examples, the VPU **108** additionally or alternatively determines whether to send the sensor data from block **602** and/or block **614** to an external destination. If the VPU **108** determines at block **622** to not send the collected information to an external destination, control returns to block **614** to access further sensor data.

When the example VPU **108** determines at block **622** to send the collected information to an external destination, the VPU **108** enables the wireless communication interface **110** (FIGS. **1A** and **1B**) (block **624**). For example, the fully active state transitioner **572** (FIG. **5B**) provides power to the wireless communication interface **110** and/or sets an enable line of the wireless communication interface **110** to its active

state. The example VPU 108 sends the collected information (block 626). For example, the VPU 108 may send the metadata generated at block 620 and/or block 608 and/or the sensor data from block 602 and/or block 614 from the mobile camera 100, 204 to a corresponding mobile phone host device 202, to another mobile camera 100, 204, and/or to the cloud system 206. In some examples, the mobile phone host device 202 and/or the other mobile camera 100, 204, in turn, send(s) the collected information to the cloud system 206. The example process of FIG. 6 ends.

FIG. 7 illustrates a block diagram of an example processor platform 700 structured to execute the instructions of FIG. 6 to implement the mobile camera 100, 204 of FIGS. 1A, 1B, and 2 and/or the VPU 108 of FIGS. 1A, 1B, 5A, 5B, and 5C. The processor platform 700 can be, for example, a camera, a computer, a self-learning machine (e.g., a neural network), a mobile device (e.g., a cell phone, a smart phone, a tablet such as an iPad™), a personal digital assistant (PDA), an Internet appliance, a digital video recorder, a gaming console, a personal video recorder, a headset or other wearable device, or any other type of computing device.

The processor platform 700 of the illustrated example includes a processor 712. The processor 712 of the illustrated example is hardware. For example, the processor 712 can be implemented by one or more integrated circuits, logic circuits, microprocessors, GPUs, DSPs, or controllers from any desired family or manufacturer. The hardware processor 712 may be a semiconductor based (e.g., silicon based) device. In some examples, the processor 712 implements the VPU 108. In this example, the processor implements the example CNN feature analyzers 114, the example computer vision algorithms 116, and/or the example digital signal processors 118 of FIG. 1A, the example motion feature detector 502, the example CNN motion activity recognizer 504, the example motion activity multiplexer 506, the example full wake-up event multiplexer 510, the example audio feature detector 514, the example voice activity detector 516, the example CNN wake-up word recognizer 518, the example CNN command word recognizer 520, the example command word multiplexer 522, the example image feature detector 528, the example CNN face detector 530, the example CNN wake-up face recognizer 532, the example CNN face recognizer 534, the example recognized face multiplexer 536, the example CNN object recognizer 542, and/or the example trigger feature multiplexers 554 of FIG. 5A, the example POR state transitioner 562, the example AoN state transitioner 564, the example primary event state transitioner 566, the example secondary event state transitioner 568, the example tertiary event state transitioner 570, and/or the example fully active state transitioner 572 of FIG. 5B, and/or the example state-order configurator 582 of FIG. 5C.

The processor 712 of the illustrated example includes a local memory 713 (e.g., a cache). The processor 712 of the illustrated example is in communication with a main memory including a volatile memory 714 and a non-volatile memory 716 via a bus 718. The volatile memory 714 may be implemented by Synchronous Dynamic Random Access Memory (SDRAM), Dynamic Random Access Memory (DRAM), RAMBUS® Dynamic Random Access Memory (RDRAM®) and/or any other type of random access memory device. The non-volatile memory 716 may be implemented by flash memory and/or any other desired type of memory device. Access to the main memory 714, 716 is controlled by a memory controller.

The processor platform 700 of the illustrated example also includes an interface circuit 720. The interface circuit 720 may be implemented by any type of interface standard, such as an Ethernet interface, a universal serial bus (USB), a Wi-Fi interface, a Bluetooth® interface, Zigbee® interface, a near field communication (NFC) interface, and/or a PCI express interface.

In the illustrated example, one or more input devices 722 are connected to the interface circuit 720. The input device(s) 722 permit(s) a user to enter data and/or commands into the processor 712. The input device(s) can be implemented by, for example, an audio sensor, a microphone, a camera (still or video), a motion sensor, a keyboard, a button, a mouse, a touchscreen, a track-pad, a trackball, isopoint and/or a voice recognition system.

One or more output devices 724 are also connected to the interface circuit 720 of the illustrated example. The output devices 724 can be implemented, for example, by display devices (e.g., a light emitting diode (LED), an organic light emitting diode (OLED), a liquid crystal display (LCD), a cathode ray tube display (CRT), an in-place switching (IPS) display, a touchscreen, etc.), a tactile output device, a printer and/or a speaker. The interface circuit 720 of the illustrated example, thus, typically includes a graphics driver card, a graphics driver chip and/or a graphics driver processor.

The interface circuit 720 of the illustrated example also includes a communication device such as a transmitter, a receiver, a transceiver, a modem, a residential gateway, a wireless access point, and/or a network interface to facilitate exchange of data with external machines (e.g., computing devices of any kind) via a network 726. The communication can be via, for example, an Ethernet connection, a digital subscriber line (DSL) connection, a telephone line connection, a coaxial cable system, a satellite system, a line-of-site wireless system, a cellular telephone system, etc.

The processor platform 700 of the illustrated example also includes one or more mass storage devices 728 for storing software and/or data. Examples of such mass storage devices 728 include floppy disk drives, hard drive disks, compact disk drives, Blu-ray disk drives, redundant array of independent disks (RAID) systems, and digital versatile disk (DVD) drives.

Machine executable instructions 732 representative of the example machine-readable instructions of FIG. 6 may be stored in the mass storage device 728, in the volatile memory 714, in the non-volatile memory 716, and/or on a removable non-transitory computer readable storage medium such as a CD or DVD.

From the foregoing, it will be appreciated that example methods, apparatus, and articles of manufacture have been disclosed to operate mobile cameras having limited power sources while enabling numerous uses for the mobile cameras for productivity, entertainment, and as assistive technologies that assist users in their day-to-day activities. Example mobile cameras disclosed herein operate in a low-power feature monitoring mode and one or more higher-power active modes. The low-power feature monitoring mode enables a mobile camera to monitor characteristics of its surrounding environment while consuming substantially little power (e.g., ~2 milliwatts). In the low-power feature monitoring mode, environment analysis logic of an example mobile camera monitors environmental characteristics to identify features of interest representing stimuli that warrant transitioning the mobile camera to a higher-power active mode in which the mobile camera can monitor additional types of environmental characteristics and/or capture high-quality visual captures. In such manners, examples

disclosed herein enable mobile cameras to operate in power-constrained configurations for long durations while the mobile cameras intelligently operate intermittently in higher-power modes to capture high-quality data such as high-resolution visual captures of their surrounding environments.

Examples disclosed herein also enable mobile cameras to transmit metadata generated from collected sensor data (e.g., motion data, audio data, visual captures, etc.) instead of transmitting the sensor data itself. Since metadata is smaller in data size than raw sensor data, transmitting the sensor data from the mobile cameras to host devices or a cloud service conserves network bandwidth, thus, reducing network congestion and increasing the speed at which such metadata can be received at its destination locations. It also reduces power consumption of the mobile cameras due to needing to transmit less data due to the metadata being of smaller data size than raw sensor data. Such power consumption reduction is especially significant with respect to using Wi-Fi communications, which can be especially demanding on power requirements for performing transmissions. Reducing power consumption in this manner is useful in small portable electronics, such as mobile cameras, that have small batteries and, thus, small charge capacities. In addition, transmitting metadata across a network from the mobile cameras protects privacies of persons and/or private/personal property by not revealing raw sensor data that could be used to identify such persons and/or private/personal property. As such, examples disclosed herein can be used to reduce network congestion and protect privacies of persons by transmitting metadata about sensor data from mobile cameras to destination locations across a network.

The following pertain to further examples disclosed herein.

Example 1 is a mobile camera. The mobile camera of Example 1 includes a first convolutional neural network to recognize a first feature in first sensor data in response to the first feature being detected in the first sensor data; a state transitioner to transition the mobile camera from a first feature detection state to a second feature detection state in response to the first convolutional neural network recognizing the first feature, the mobile camera to operate using higher power consumption in the second feature detection state than in the first feature detection state; a second convolutional neural network to recognize a second feature in second sensor data in the second feature detection state; and a communications interface to send to an external device at least one of first metadata corresponding to the first feature or second metadata corresponding to the second feature.

In Example 2, the subject matter of Example 1 can optionally include an image feature detector in circuit with a low-resolution camera, the low-resolution camera to provide the first sensor data in the first feature detection state, the image feature detector to detect the first feature in the first sensor data; and a high-resolution camera having a standby mode when the mobile camera is in the first feature detection state and having an active mode when the mobile camera is in the second feature detection state.

In Example 3, the subject matter of any one of Examples 1-2 can optionally include a feature detector to determine whether the first feature satisfies a feature trigger threshold, the first convolutional neural network to generate the first metadata in response the first feature satisfying the feature trigger threshold.

In Example 4, the subject matter of any one of Examples 1-3 can optionally include a motion feature detector in

circuit with an inertial measurement unit, the first sensor data provided by a motion sensor in circuit with the inertial measurement unit, and the motion feature detector to detect the first feature in the first sensor data.

In Example 5, the subject matter of any one of Examples 1-4 can optionally include that the first convolutional neural network is to generate the first metadata by comparing the first feature to a reference motion feature definition in a reference motion metadata library.

In Example 6, the subject matter of any one of Examples 1-5 can optionally include an audio feature detector in circuit with an audio codec, the first sensor data being audio data, and the audio feature detector to detect the first feature in the audio data.

In Example 7, the subject matter of any one of Examples 1-6 can optionally include that the first convolutional neural network is to generate the first metadata by comparing the first feature to a reference audio feature definition in a reference audio metadata library.

In Example 8, the subject matter of any one of Examples 1-7 can optionally include that the audio feature detector is to detect the first feature in the audio data based on at least one of: (a) speech, (b) a vehicle sound, (c) or a rate of change in an audio signal reflected in the audio data.

In Example 9, the subject matter of any one of Examples 1-8 can optionally include an image feature detector in circuit with a low-resolution camera, the first sensor data being a visual capture, and the image feature detector to detect the first feature in the visual capture.

In Example 10, the subject matter of any one of Examples 1-9 can optionally include that the first convolutional neural network is to generate the first metadata by comparing the first feature to a reference visual feature definition in a reference image metadata library.

In Example 11, the subject matter of any one of Examples 1-10 can optionally include that the image feature detector is to detect the first feature in the visual capture based on at least one of: (a) an edge, (b) a line, (c) or a face in the visual capture.

In Example 12, the subject matter of any one of Examples 1-11 can optionally include that the external device is at least one of a mobile phone, a second mobile camera, or a wearable device.

Example 13 is a mobile camera. The mobile camera of Example 13 includes first means for recognizing a first feature in first sensor data in response to the first feature being detected in the first sensor data; means for transitioning the mobile camera from a first feature detection state to a second feature detection state in response to the recognizing of the first feature, the second feature detection state to contribute to relatively higher power consumption by the mobile camera than the first feature detection state; second means for recognizing a second feature in second sensor data collected; and means for communicating to an external device at least one of first metadata corresponding to the first feature or second metadata corresponding to the second feature.

In Example 14, the subject matter of Example 13 can optionally include means for detecting features to detect the first feature in the first sensor data.

In Example 15, the subject matter of any one of Examples 13-14 can optionally include the means for detecting features is to determine detect the first feature based on determining that the first feature satisfies a feature trigger threshold, the first means for recognizing to generate the first metadata after the means for detecting features determines that the first feature satisfies the feature trigger threshold.

In Example 16, the subject matter of any one of Examples 13-15 can optionally include means for detecting features to detect the first feature in motion data of the first sensor data provided by an inertial measurement unit.

In Example 17, the subject matter of any one of Examples 13-16 can optionally include the first means for recognizing is to compare the first feature to a reference motion feature definition in a reference motion metadata library to generate the first metadata.

In Example 18, the subject matter of any one of Examples 13-17 can optionally include means for detecting features to detect the first feature in audio data of the first sensor data.

In Example 19, the subject matter of any one of Examples 13-18 can optionally include that the first means for recognizing is to compare the first feature to a reference audio feature definition in a reference audio metadata library to generate the first metadata.

In Example 20, the subject matter of any one of Examples 13-19 can optionally include that the means for detecting features is to detect the first feature in the audio data based on at least one of: (a) speech, (b) a vehicle sound, (c) or a rate of change in an audio signal reflected in the audio data.

In Example 21, the subject matter of any one of Examples 13-20 can optionally include means for detecting features is to detect the first feature in a visual capture represented by the first sensor data.

In Example 22, the subject matter of any one of Examples 13-21 can optionally include that the first means for recognizing is to compare the first feature to a reference visual feature definition in a reference image metadata library to generate the first metadata.

In Example 23, the subject matter of any one of Examples 13-22 can optionally include that the means for detecting features is to detect the first feature in the visual capture based on at least one of: (a) an edge, (b) a line, (c) or a face in the visual capture.

In Example 24, the subject matter of any one of Examples 13-23 can optionally include that the external device is at least one of a mobile phone, a second mobile camera, or a wearable device.

Example 25 is a non-transitory computer readable storage medium comprising instructions that, when executed, cause at least one processor to at least recognize a first feature in first sensor data in response to the first feature being detected in the first sensor data; transition a mobile camera from a first feature detection state to a second feature detection state in response to the recognizing of the first feature, the mobile camera to operate using higher power consumption in the second feature detection state than in the first feature detection state; recognize a second feature in second sensor data in the second feature detection state; and send to an external device at least one of first metadata corresponding to the first feature or second metadata corresponding to the second feature.

In Example 26, the subject matter of Example 25 can optionally include that the instructions further cause the at least one processor to set a high-resolution camera to a standby mode in the first feature detection state; access the first sensor data as a visual capture provided by a low-resolution camera in the first feature detection state; detect the first feature in the first sensor data; and set the high-resolution camera to an active mode in the second feature detection state.

In Example 27, the subject matter of any one of Examples 25-26 can optionally include that the instructions further cause the at least one processor to determine whether the

first feature satisfies a feature trigger threshold; and generate the first metadata in response to the first feature satisfying the feature trigger threshold.

In Example 28, the subject matter of any one of Examples 25-27 can optionally include that the instructions further cause the at least one processor to access the first sensor data as motion data provided by a motion sensor in circuit with an inertial measurement unit; and detect the first feature in the motion data.

In Example 29, the subject matter of any one of Examples 25-28 can optionally include that the instructions are further to cause the at least one processor to generate the first metadata by comparing the first feature to a reference motion feature definition in a reference motion metadata library.

In Example 30, the subject matter of any one of Examples 25-29 can optionally include that the instructions are further to cause the at least one processor to access the first sensor data as audio data provided by an audio codec; and detect the first feature in the audio data.

In Example 31, the subject matter of any one of Examples 25-30 can optionally include that the instructions are further to cause the at least one processor to generate the first metadata by comparing the first feature to a reference audio feature definition in a reference audio metadata library.

In Example 32, the subject matter of any one of Examples 25-31 can optionally include that the instructions are further to cause the at least one processor to detect the first feature in the audio data based on at least one of: (a) speech, (b) a vehicle sound, (c) or a rate of change in an audio signal reflected in the audio data.

In Example 33, the subject matter of any one of Examples 25-32 can optionally include that the instructions are further to cause the at least one processor to access the first sensor data as a visual capture provided by a low-resolution camera; and detect the first feature in the visual capture.

In Example 34, the subject matter of any one of Examples 25-33 can optionally include that the instructions are further to cause the at least one processor to generate the first metadata by comparing the first feature to a reference visual feature definition in a reference image metadata library.

In Example 35, the subject matter of any one of Examples 25-34 can optionally include that the instructions are further to cause the at least one processor to detect the first feature in the visual capture based on at least one of: (a) an edge, (b) a line, (c) or a face in the visual capture.

In Example 36, the subject matter of any one of Examples 25-35 can optionally include that the external device is at least one of a mobile phone, a second mobile camera, or a wearable device.

Example 37 is a method to operate a mobile camera. The method of Example 37 includes recognizing, by executing an instruction with a processor, a first feature in first sensor data in response to the first feature being detected in the first sensor data; transitioning, by executing an instruction with the processor, the mobile camera from a first feature detection state to a second feature detection state in response to the recognizing of the first feature, the mobile camera to operate using higher power consumption in second feature detection state than in the first feature detection state; recognizing, by executing an instruction with the processor, a second feature in second sensor data in the second feature detection state; and sending to an external device, by executing an instruction with the processor, at least one of first metadata corresponding to the first feature or second metadata corresponding to the second feature.

In Example 38, the subject matter of Example 37 can optionally include setting a high-resolution camera to a standby mode in the first feature detection state; accessing the first sensor data as a visual capture provided by a low-resolution camera in the first feature detection state; 5 detecting the first feature in the first sensor data; and setting the high-resolution camera to an active mode in the second feature detection state.

In Example 39, the subject matter of any one of Examples 37-38 can optionally include determining whether the first feature satisfies a feature trigger threshold; and generating the first metadata in response the first feature satisfying the feature trigger threshold. 10

In Example 40, the subject matter of any one of Examples 37-39 can optionally include accessing the first sensor data as motion data provided by a motion sensor in circuit with an inertial measurement unit; and detecting the first feature in the motion data. 15

In Example 41, the subject matter of any one of Examples 37-40 can optionally include generating the first metadata by comparing the first feature to a reference motion feature definition in a reference motion metadata library. 20

In Example 42, the subject matter of any one of Examples 37-41 can optionally include accessing the first sensor data as audio data provided by an audio codec; and detecting the first feature in the audio data. 25

In Example 43, the subject matter of any one of Examples 37-42 can optionally include generating the first metadata by comparing the first feature to a reference audio feature definition in a reference audio metadata library. 30

In Example 44, the subject matter of any one of Examples 37-43 can optionally include detecting the first feature in the audio data based on at least one of: (a) speech, (b) a vehicle sound, (c) or a rate of change in an audio signal reflected in the audio data. 35

In Example 45, the subject matter of any one of Examples 37-44 can optionally include accessing the first sensor data as a visual capture provided by a low-resolution camera; and detecting the first feature in the visual capture.

In Example 46, the subject matter of any one of Examples 37-45 can optionally include generating the first metadata by comparing the first feature to a reference visual feature definition in a reference image metadata library. 40

In Example 47, the subject matter of any one of Examples 37-46 can optionally include detecting the first feature in the visual capture based on at least one of: (a) an edge, (b) a line, (c) or a face in the visual capture. 45

In Example 48, the subject matter of any one of Examples 37-47 can optionally include that the external device is at least one of a mobile phone, a second mobile camera, or a wearable device. 50

Although certain example methods, apparatus and articles of manufacture have been disclosed herein, the scope of coverage of this patent is not limited thereto. On the contrary, this patent covers all methods, apparatus and articles of manufacture fairly falling within the scope of the claims of this patent. 55

What is claimed is:

1. A mobile camera, comprising:

a motion feature detector to detect a motion feature in motion sensor data;

an audio feature detector to detect an audio feature in audio sensor data;

a first convolutional neural network to recognize the audio feature in the audio sensor data in response to the audio feature being detected in the audio sensor data; 65

a first state transitioner to transition the mobile camera from a motion feature detection state to an audio feature detection state in response to the motion feature detector detecting the motion feature in the motion sensor data, a first power state of the motion feature detection state corresponding to lower power consumption than a second power state of the audio feature detection state;

a second state transitioner to transition the mobile camera from the audio feature detection state to a low-resolution camera feature detection state in response to the first convolutional neural network recognizing the audio feature, the mobile camera to operate using higher power consumption in a third power state corresponding to the low-resolution camera feature detection state than in the second power state corresponding to the audio feature detection state;

a second convolutional neural network to recognize an image feature in visual capture data in the low-resolution camera feature detection state; and

a communications interface to send to an external device at least one of: (a) first metadata corresponding to the motion feature or the audio feature, or (b) second metadata corresponding to the image feature.

2. The mobile camera as defined in claim 1, further including:

an image feature detector in circuit with a low-resolution camera, the low-resolution camera to provide the visual capture data in the low-resolution camera feature detection state, the image feature detector to detect the image feature in the visual capture data; and

a high-resolution camera having a standby mode when the mobile camera is in the low-resolution camera feature detection state and having an active mode when the mobile camera is in high-resolution camera feature detection state. 35

3. The mobile camera as defined in claim 1, further including a feature detector to determine whether the audio feature satisfies a feature trigger threshold, the first convolutional neural network to generate the first metadata in response to the audio feature satisfying the feature trigger threshold.

4. The mobile camera as defined in claim 1, wherein the motion feature detector is in circuit with an inertial measurement unit, the motion sensor data provided by a motion sensor in circuit with the inertial measurement unit, and the motion feature detector to detect the motion feature in the motion sensor data.

5. The mobile camera as defined in claim 4, wherein the first convolutional neural network is to generate the first metadata by comparing the motion feature to a reference motion feature definition in a reference motion metadata library.

6. The mobile camera as defined in claim 1, wherein the audio feature detector is in circuit with an audio codec, the audio feature detector to detect the audio feature in the audio data.

7. The mobile camera as defined in claim 6, wherein the first convolutional neural network is to generate the first metadata by comparing the audio feature to a reference audio feature definition in a reference audio metadata library.

8. The mobile camera as defined in claim 6, wherein the audio feature detector is to detect the audio feature in the audio data based on at least one of: (a) speech, (b) a vehicle sound, (c) or a rate of change in an audio signal reflected in the audio data. 65

9. The mobile camera as defined in claim 1, further including an image feature detector in circuit with a low-resolution camera, the image feature detector to detect the image feature in the visual capture data.

10. The mobile camera as defined in claim 9, wherein the second convolutional neural network is to generate the second metadata by comparing the image feature to a reference visual feature definition in a reference image metadata library.

11. The mobile camera as defined in claim 9, wherein the image feature detector is to detect the image feature in the visual capture data based on at least one of: (a) an edge, (b) a line, (c) or a face in the visual capture data.

12. The mobile camera as defined in claim 1, wherein the external device is at least one of a mobile phone, a second mobile camera, or a wearable device.

13. A mobile camera, comprising:

first means for detecting a motion feature in motion sensor data;

second means for detecting an audio feature in audio sensor data;

first means for recognizing an audio feature in the audio sensor data in response to the audio feature being detected in the audio sensor data;

first means for transitioning the mobile camera from a motion feature detection state to an audio feature detection state in response to the detecting of the motion feature in the motion sensor data, a first power state of the motion feature detection state corresponding to lower power consumption than a second power state of the audio feature detection state;

second means for transitioning the mobile camera from the audio feature detection state to a low-resolution camera feature detection state in response to the recognizing of the audio feature, the low-resolution camera feature detection state to contribute to relatively higher power consumption by the mobile camera than the audio feature detection state;

second means for recognizing an image feature in visual capture data in the low-resolution camera feature detection state; and

means for communicating to an external device at least one of: (a) first metadata corresponding to the motion feature or the audio feature, or (b) second metadata corresponding to the image feature.

14. The mobile camera as defined in claim 13, wherein the second means for detecting the audio feature is to detect a presence of the audio feature in the audio sensor data, the presence of the audio feature in the audio sensor data to cause the first means for recognizing to recognize the audio feature in the audio sensor data.

15. The mobile camera as defined in claim 13, wherein the second means for detecting the audio feature is to detect the audio feature based on determining that the audio feature satisfies a feature trigger threshold, the first means for recognizing to generate the first metadata after the second means for detecting the audio feature determines that the audio feature satisfies the feature trigger threshold.

16. The mobile camera as defined in claim 13, wherein the first means for detecting the motion feature is to detect the motion feature in the motion sensor data provided by an inertial measurement unit.

17. The mobile camera as defined in claim 16, wherein the first means for recognizing is to compare the motion feature to a reference motion feature definition in a reference motion metadata library to generate the first metadata.

18. The mobile camera as defined in claim 13, wherein the second means for detecting the audio feature is to detect the audio feature in the audio sensor data based on the audio feature having at least one of sufficient amplitude or sufficient duration to satisfy a threshold.

19. The mobile camera as defined in claim 18, wherein the first means for recognizing is to compare the audio feature to a reference audio feature definition in a reference audio metadata library to generate the first metadata.

20. The mobile camera as defined in claim 18, wherein the second means for detecting the audio feature is to detect the audio feature in the audio sensor data based on at least one of: (a) speech, (b) a vehicle sound, (c) or a rate of change in an audio signal reflected in the audio data.

21. The mobile camera as defined in claim 13, further including third means for detecting the image feature in the visual capture data.

22. The mobile camera as defined in claim 21, wherein the second means for recognizing is to compare the image feature to a reference visual feature definition in a reference image metadata library to generate the second metadata.

23. The mobile camera as defined in claim 21, wherein the third means for detecting the image feature in the visual capture data is based on at least one of: (a) an edge, (b) a line, (c) or a face in the visual capture data.

24. The mobile camera as defined in claim 13, wherein the external device is at least one of a mobile phone, a second mobile camera, or a wearable device.

25. A non-transitory computer readable storage medium comprising instructions that, when executed, cause at least one processor to at least:

detect a motion feature in motion sensor data;

detect an audio feature in audio sensor data;

recognize an audio feature in the audio sensor data in response to the audio feature being detected in the audio sensor data;

transition a mobile camera from a motion feature detection state to an audio feature detection state in response to the motion feature detected in the motion sensor data, a first power state of the motion feature detection state corresponding to lower power consumption than a second power state of the audio feature detection state; transition the mobile camera from the audio feature detection state to a low-resolution camera feature detection state in response to the recognizing of the audio feature, the mobile camera to operate using higher power consumption in the low-resolution camera feature detection state than in the audio feature detection state;

recognize an image feature in visual capture data in the low-resolution camera feature detection state; and

send to an external device at least one of: (a) first metadata corresponding to the motion feature or the audio feature, or (b) second metadata corresponding to the image feature.