

US010567070B2

(12) **United States Patent**
Jalali

(10) **Patent No.:** **US 10,567,070 B2**
(45) **Date of Patent:** **Feb. 18, 2020**

(54) **AIR TO GROUND NETWORK FOR BROADBAND ACCESS TO AERIAL PLATFORMS**

24/02 (2013.01); *H04W 72/044* (2013.01);
H04W 72/085 (2013.01); *H04W 84/005*
(2013.01)

(71) Applicant: **Ahmad Jalali**, Rancho Santa Fe, CA (US)

(58) **Field of Classification Search**

CPC H04B 7/18504;
H04W 16/28; H04W 72/085; H04W
72/044; H04W 84/005

(72) Inventor: **Ahmad Jalali**, Rancho Santa Fe, CA (US)

USPC 370/316
See application file for complete search history.

(*) Notice: Subject to any disclaimer, the term of this patent is extended or adjusted under 35 U.S.C. 154(b) by 0 days.

(56) **References Cited**

U.S. PATENT DOCUMENTS

(21) Appl. No.: **16/205,700**

4,675,880 A * 6/1987 Davarian H04B 7/005
332/145

(22) Filed: **Nov. 30, 2018**

7,006,794 B1 * 2/2006 Lockie H04B 7/0408
455/62

(65) **Prior Publication Data**

2001/0033600 A1* 10/2001 Yang H01Q 1/246
375/130

US 2019/0173568 A1 Jun. 6, 2019

(Continued)

Related U.S. Application Data

Primary Examiner — Rafael Pérez-Gutiérrez

(63) Continuation-in-part of application No. 15/906,483, filed on Feb. 27, 2018.

Assistant Examiner — Mark G. Pannell

(60) Provisional application No. 62/593,754, filed on Dec. 1, 2017, provisional application No. 62/542,939, filed on Aug. 9, 2017, provisional application No. 62/480,485, filed on Apr. 2, 2017.

(74) *Attorney, Agent, or Firm* — Ahmad Jalali

(51) **Int. Cl.**

H04B 7/185 (2006.01)
H04W 4/00 (2018.01)
H04B 1/00 (2006.01)
H04W 16/28 (2009.01)
H04W 72/08 (2009.01)
H04W 72/04 (2009.01)
H04L 25/00 (2006.01)
H04W 24/02 (2009.01)
H04W 84/00 (2009.01)

(57) **ABSTRACT**

A terrestrial communications network for providing broadband internet access to aerial platforms is described. In some embodiments, the cell site sector communications equipment comprises of at least two radio modules and two antenna apertures, the cell site transmits data to an aerial platform on only one antenna aperture, but receives from the aerial platform on all antenna apertures. In some embodiments, the cell site communications equipment divides each of the N data packet streams destined to N aerial platforms into multiple data packet sub-streams and sends each data packet sub-stream of an aerial platform on a different antenna aperture using a different frequency channel or antenna polarization, forming N beams from each antenna aperture, one beam toward each aerial platform.

(52) **U.S. Cl.**

CPC *H04B 7/18504* (2013.01); *H04L 25/00*
(2013.01); *H04W 16/28* (2013.01); *H04W*

12 Claims, 18 Drawing Sheets

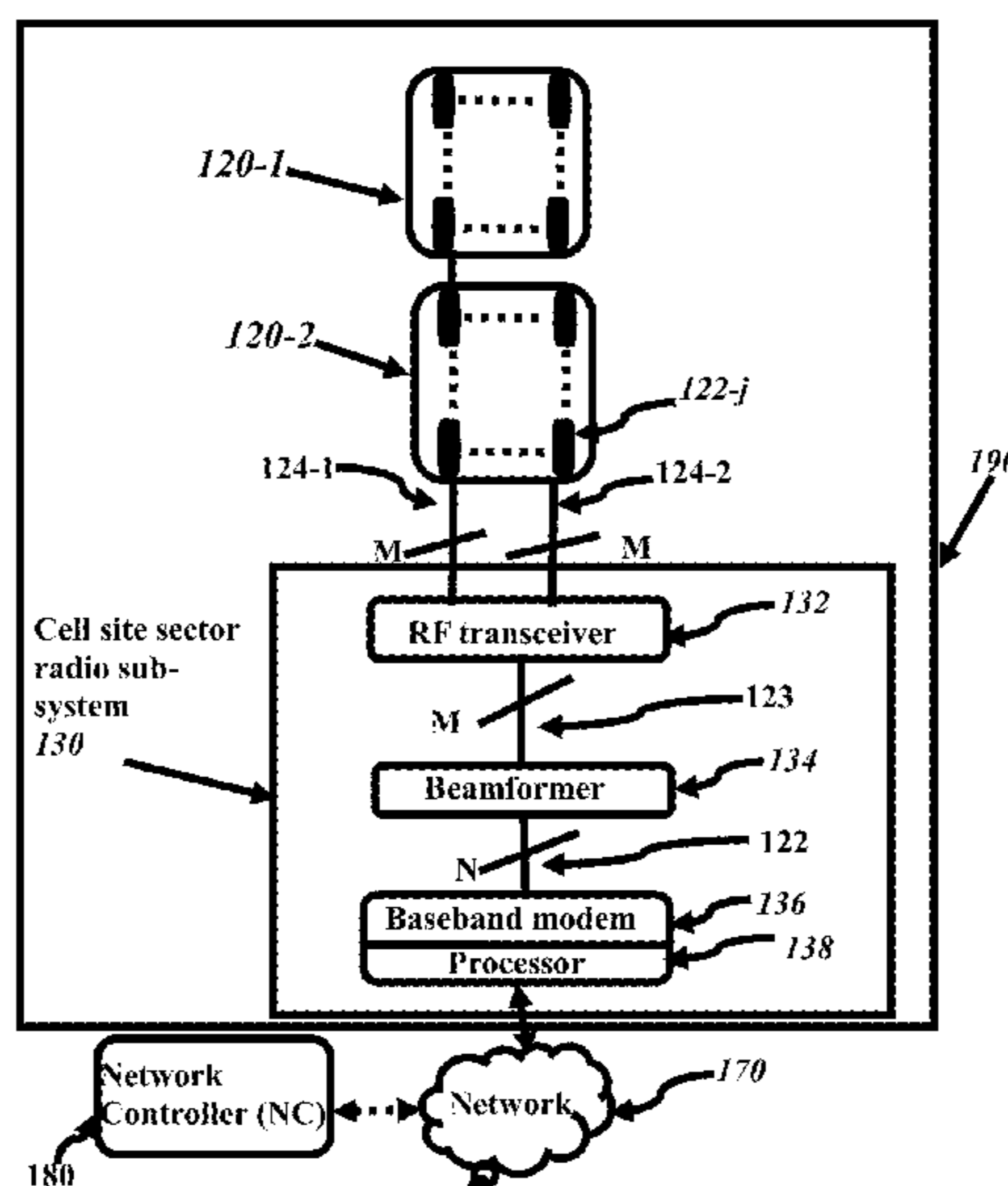

(56)

References Cited

U.S. PATENT DOCUMENTS

2002/0146029 A1* 10/2002 Kavak H04B 7/0617
370/441
2003/0123485 A1* 7/2003 Yi H04W 28/06
370/477
2006/0034217 A1* 2/2006 Kwon H04W 40/248
370/328
2010/0002725 A1* 1/2010 Oh H04W 16/02
370/468
2010/0290566 A1* 11/2010 Nibe H04B 1/40
375/340
2011/0285582 A1* 11/2011 Zhang G01S 7/024
342/26 R
2014/0093240 A1* 4/2014 Mertz H04J 14/0279
14/279
2014/0184455 A1* 7/2014 Lea H01Q 9/285
343/745
2015/0236778 A1* 8/2015 Jalali H04W 84/06
370/316
2015/0304885 A1* 10/2015 Jalali H04L 5/006
370/329
2016/0211898 A1* 7/2016 Cai H04B 7/0617

* cited by examiner

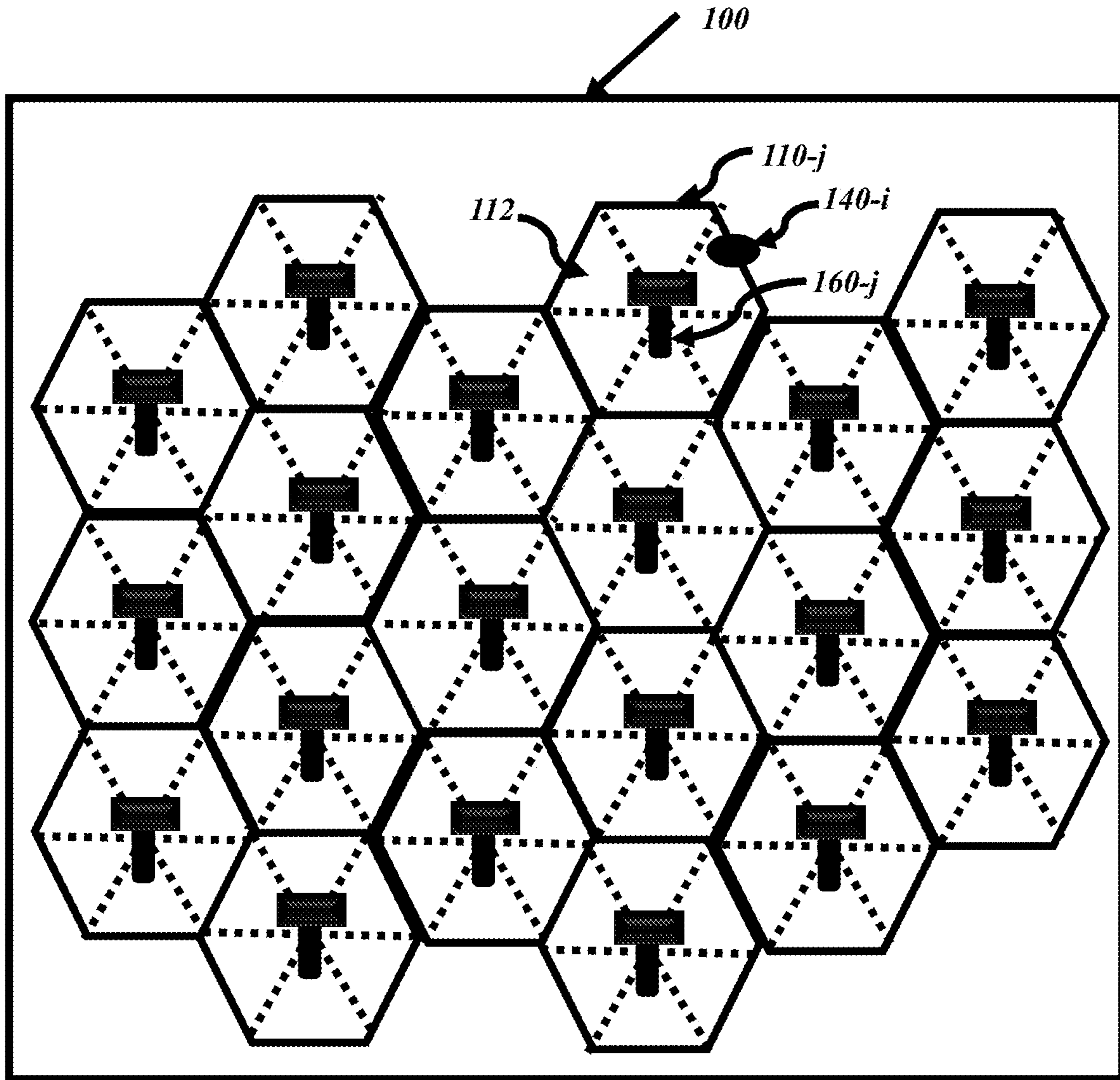

FIG. 1

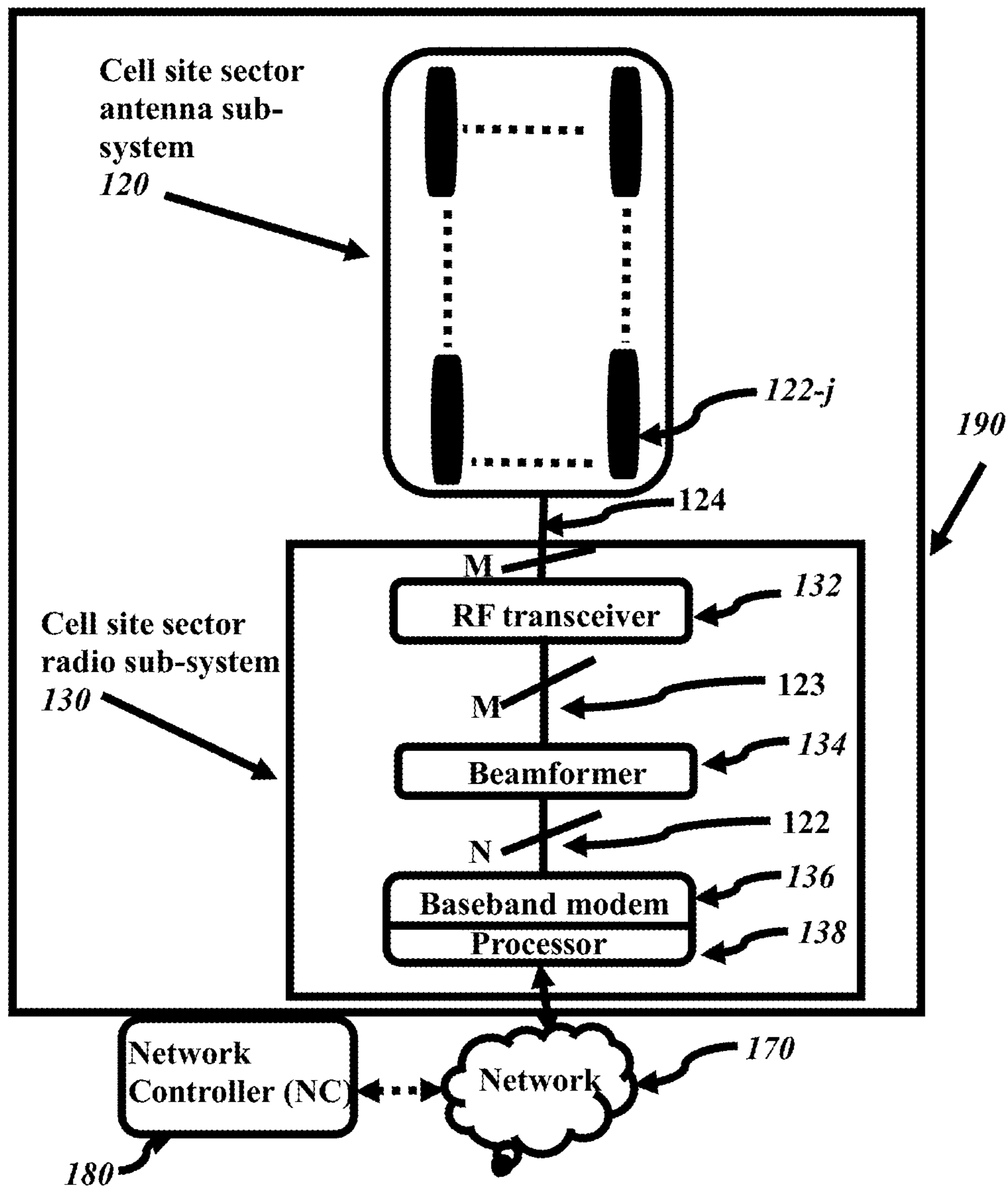

FIG. 2A

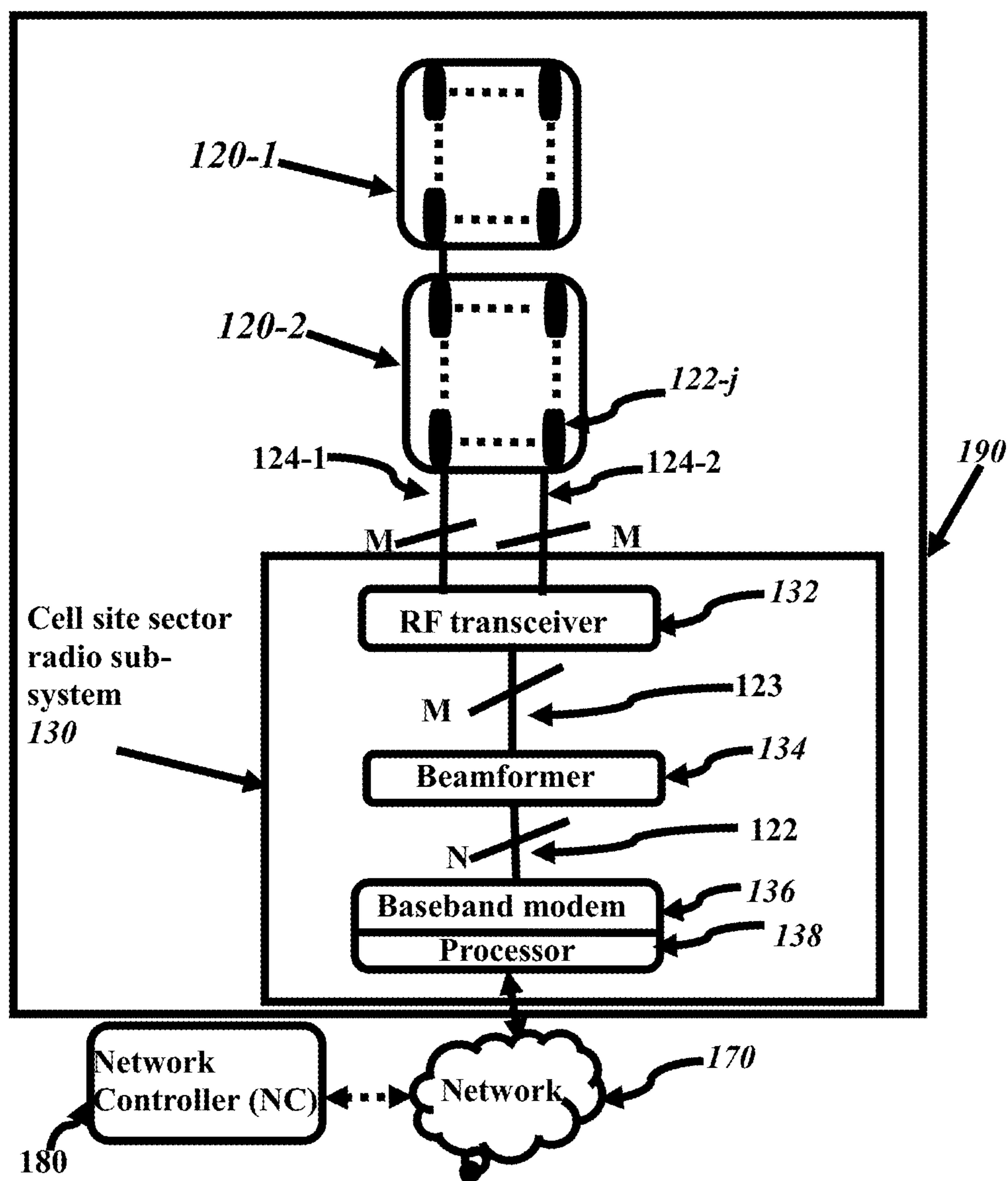

FIG. 2B

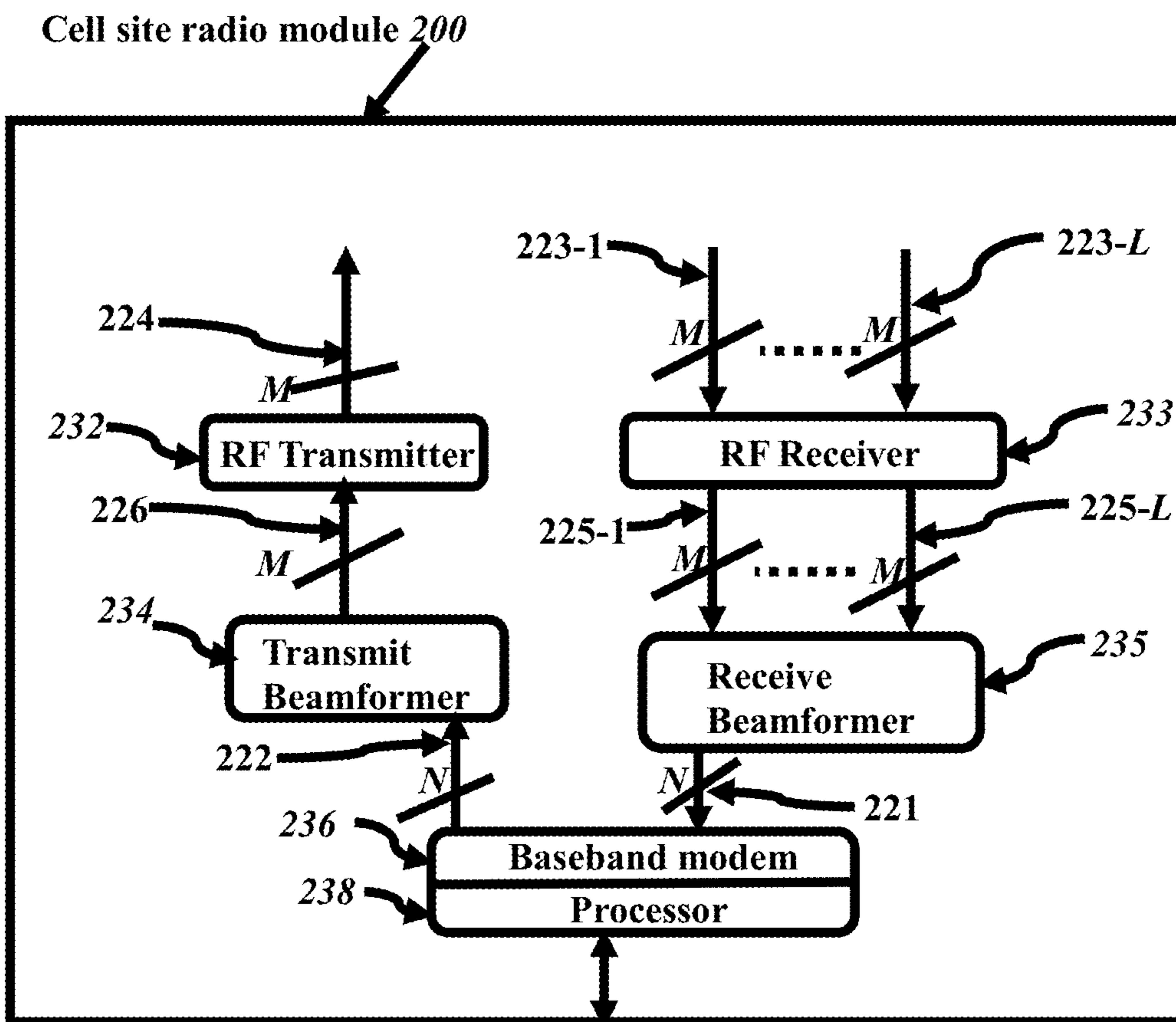

FIG. 2C

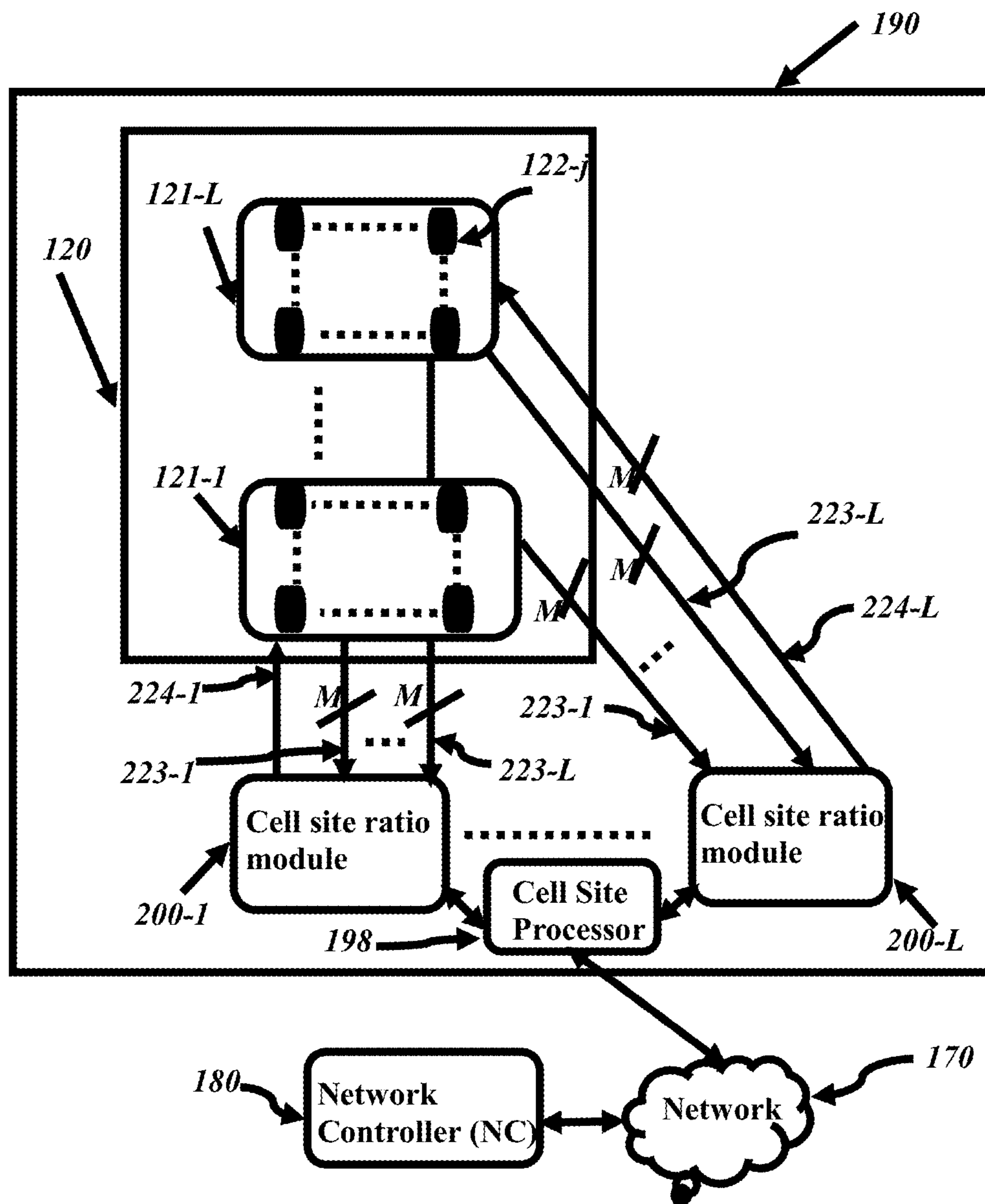

FIG. 2D

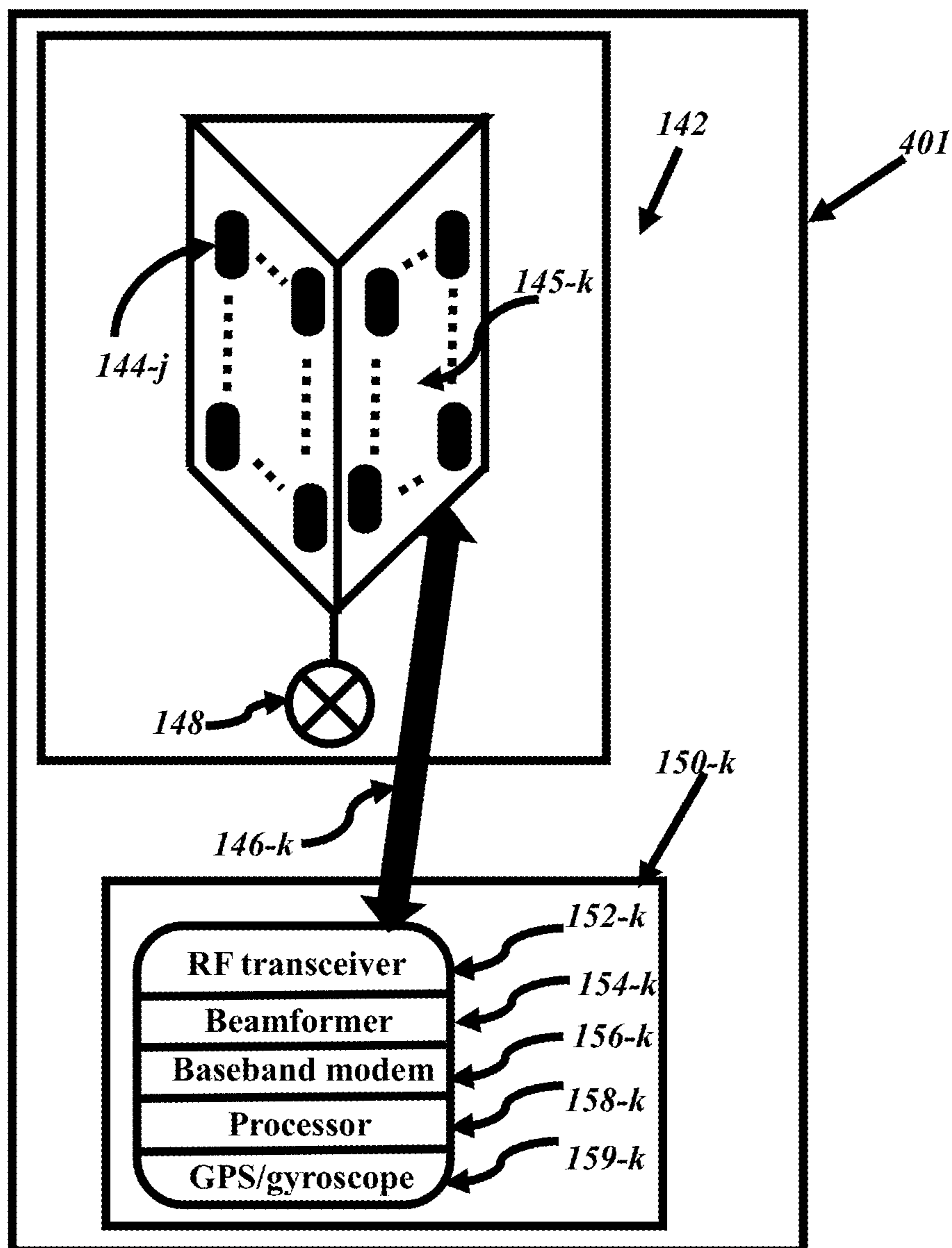

FIG. 3A

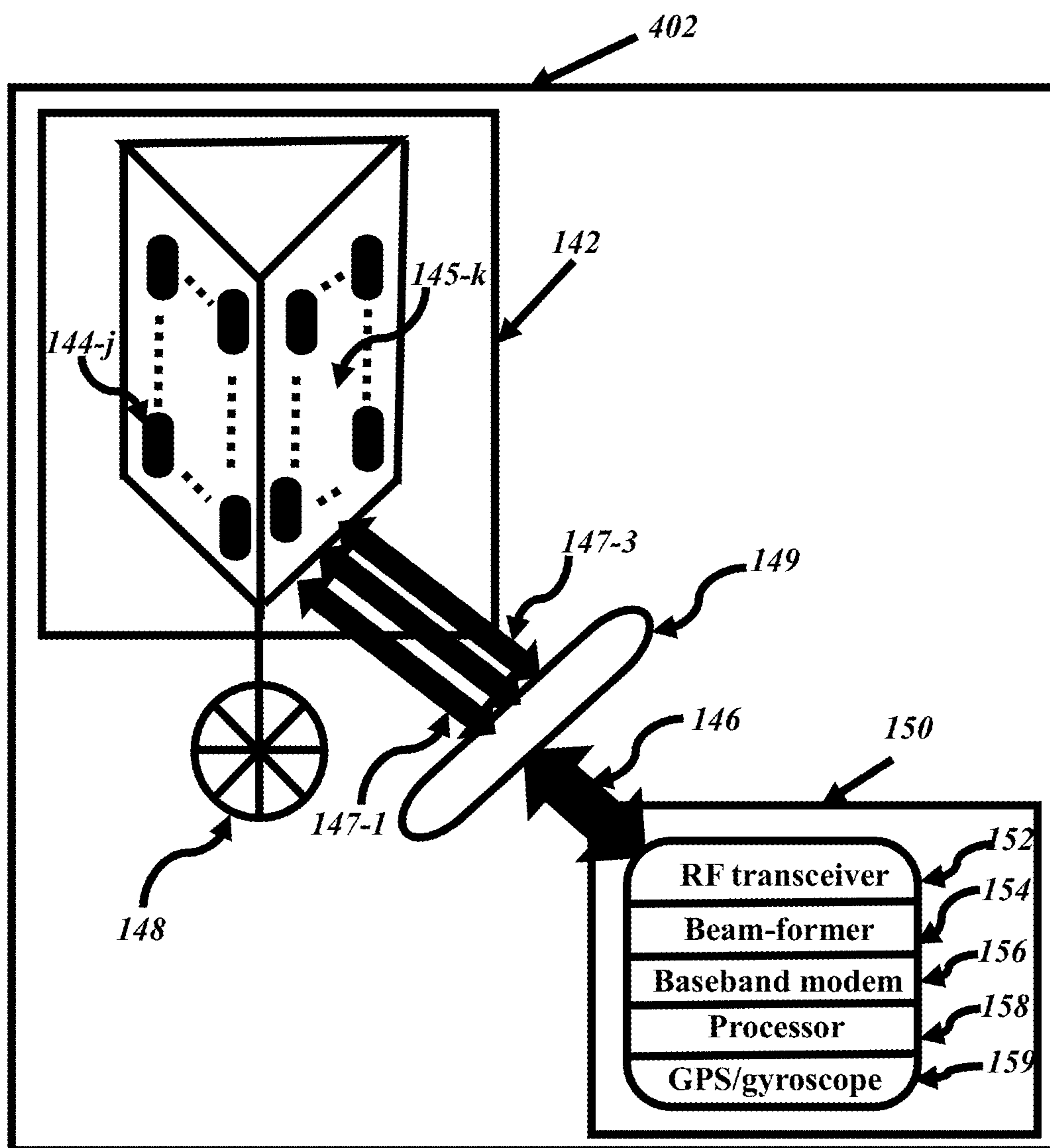

FIG. 3B

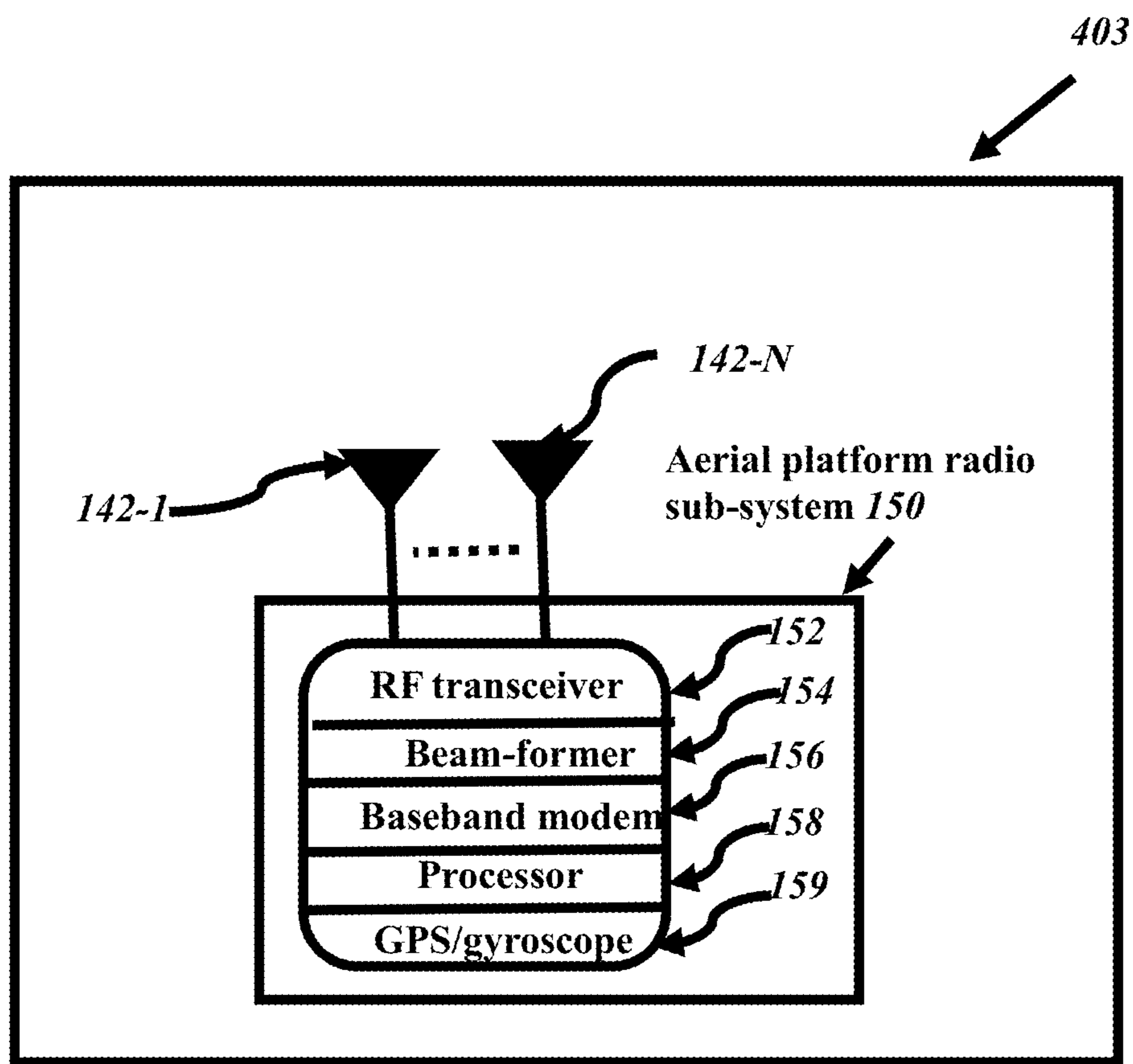

FIG. 3C

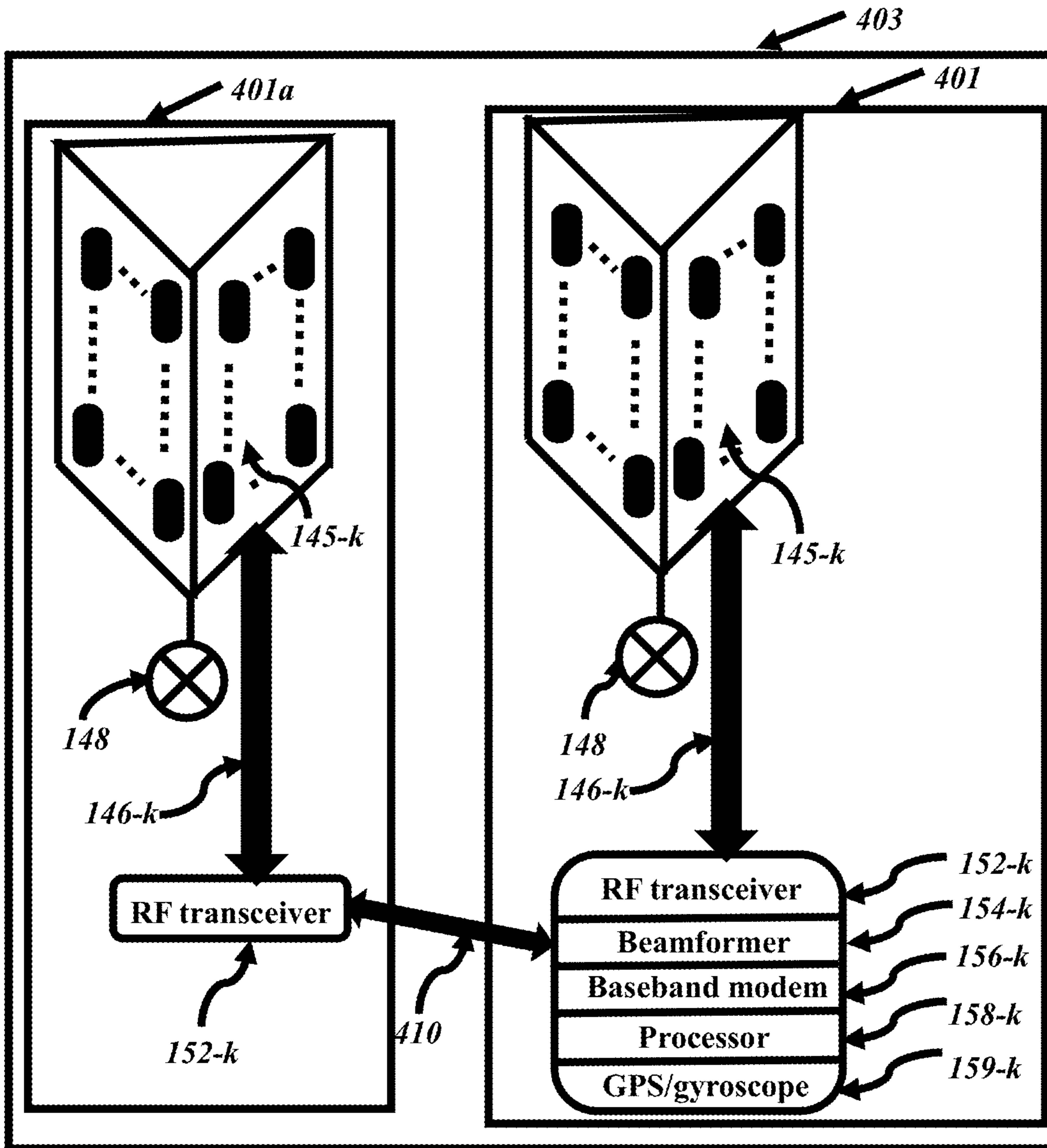

FIG. 3D

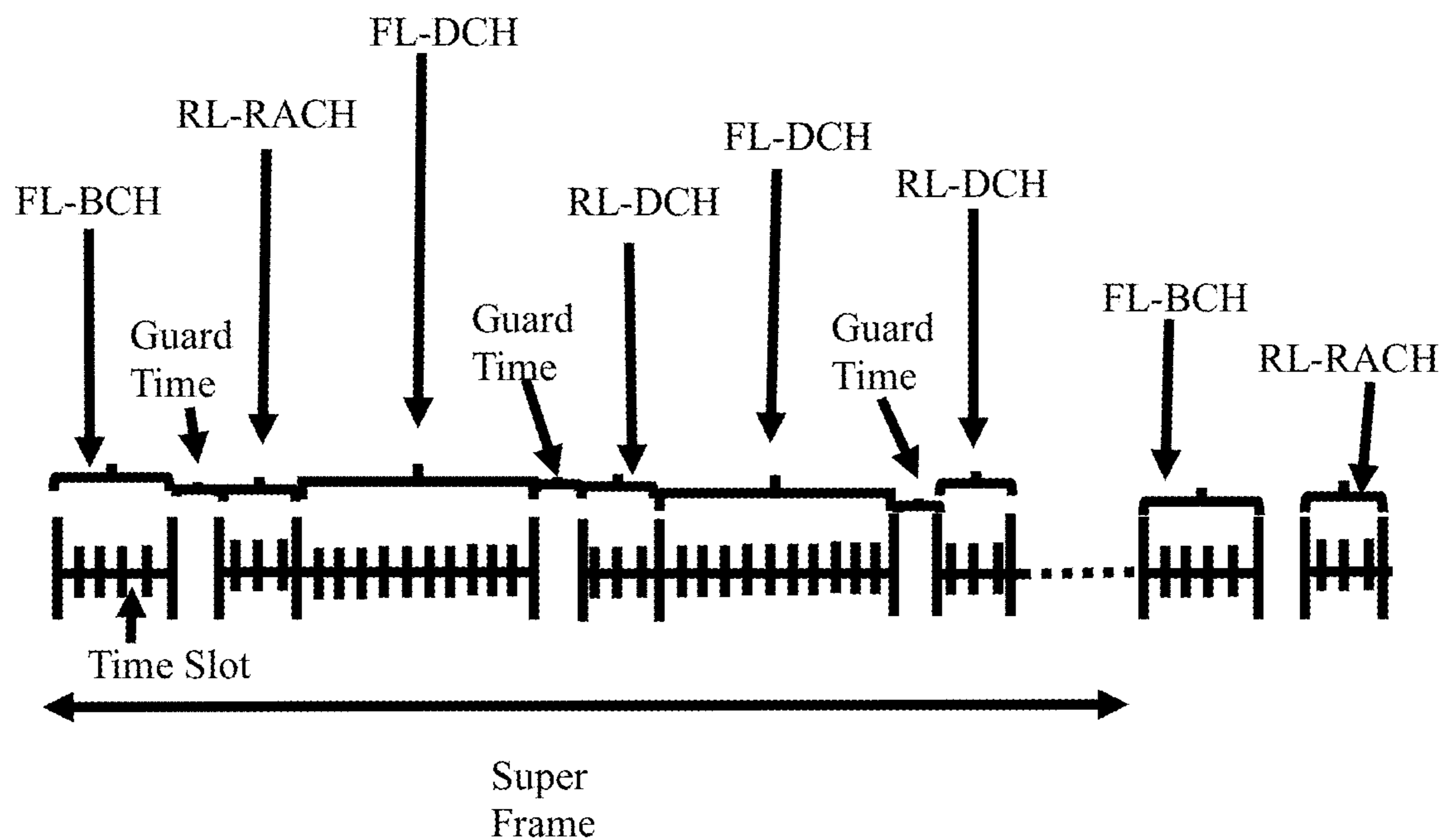

FIG. 4A

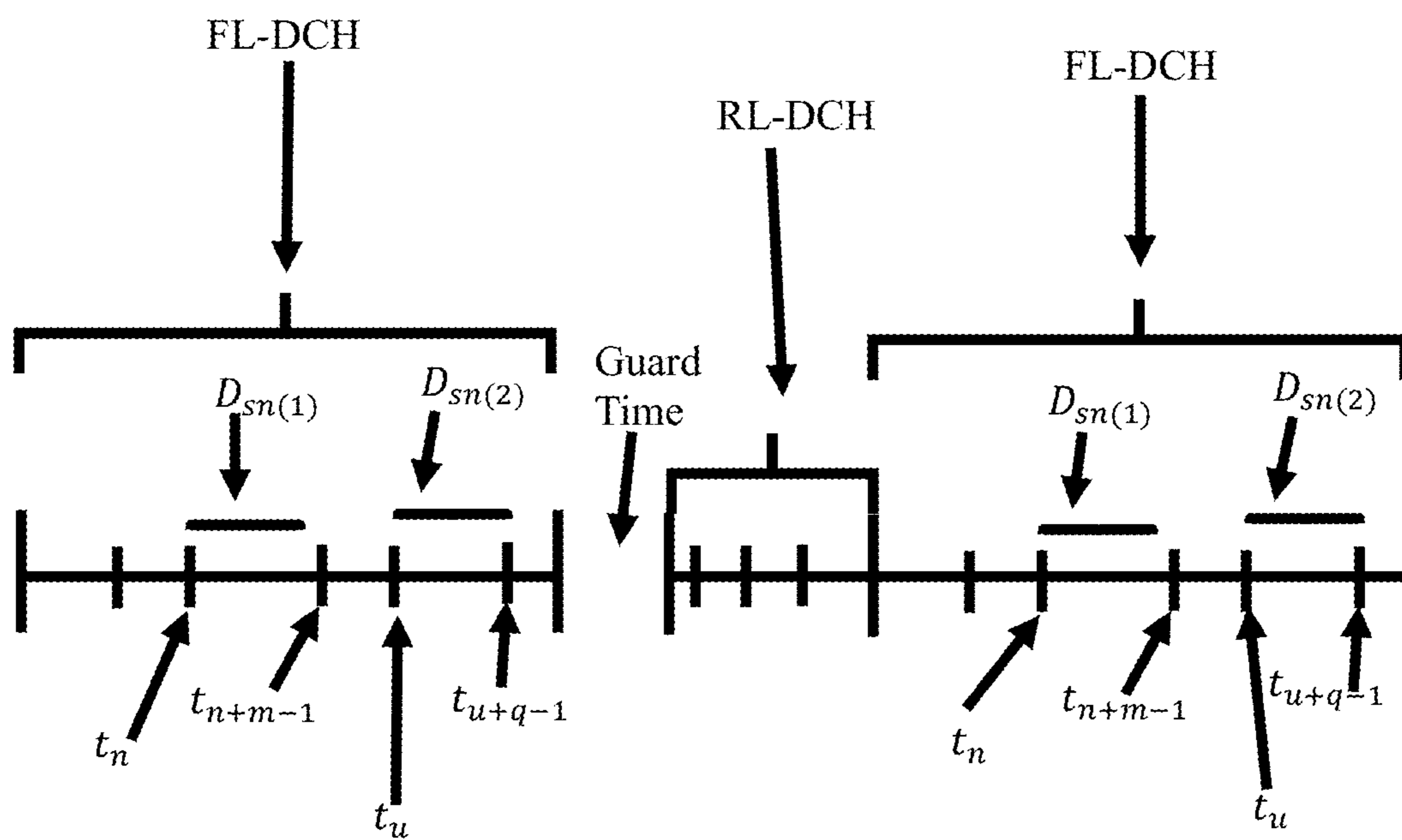

FIG. 4B

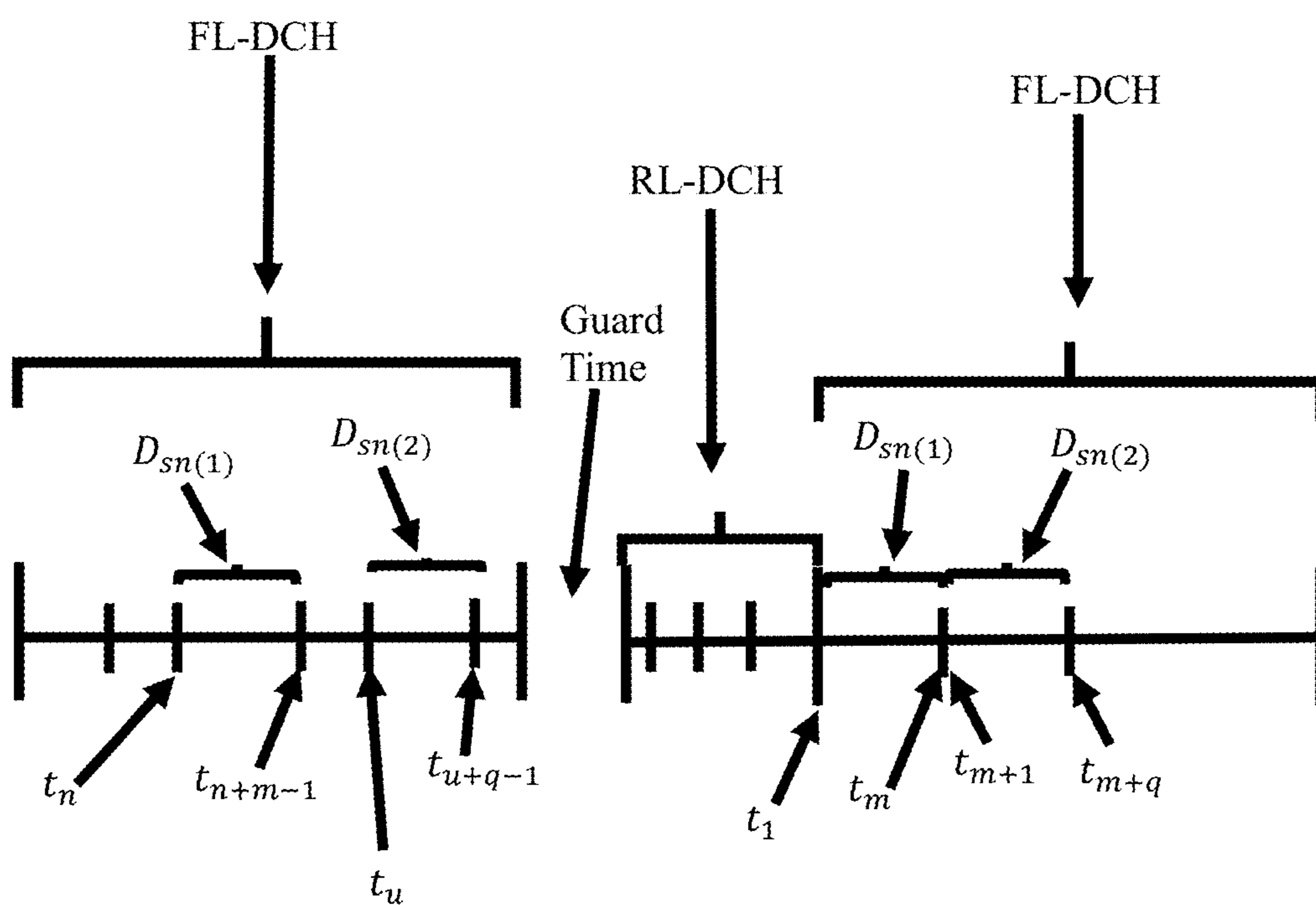

FIG. 4C

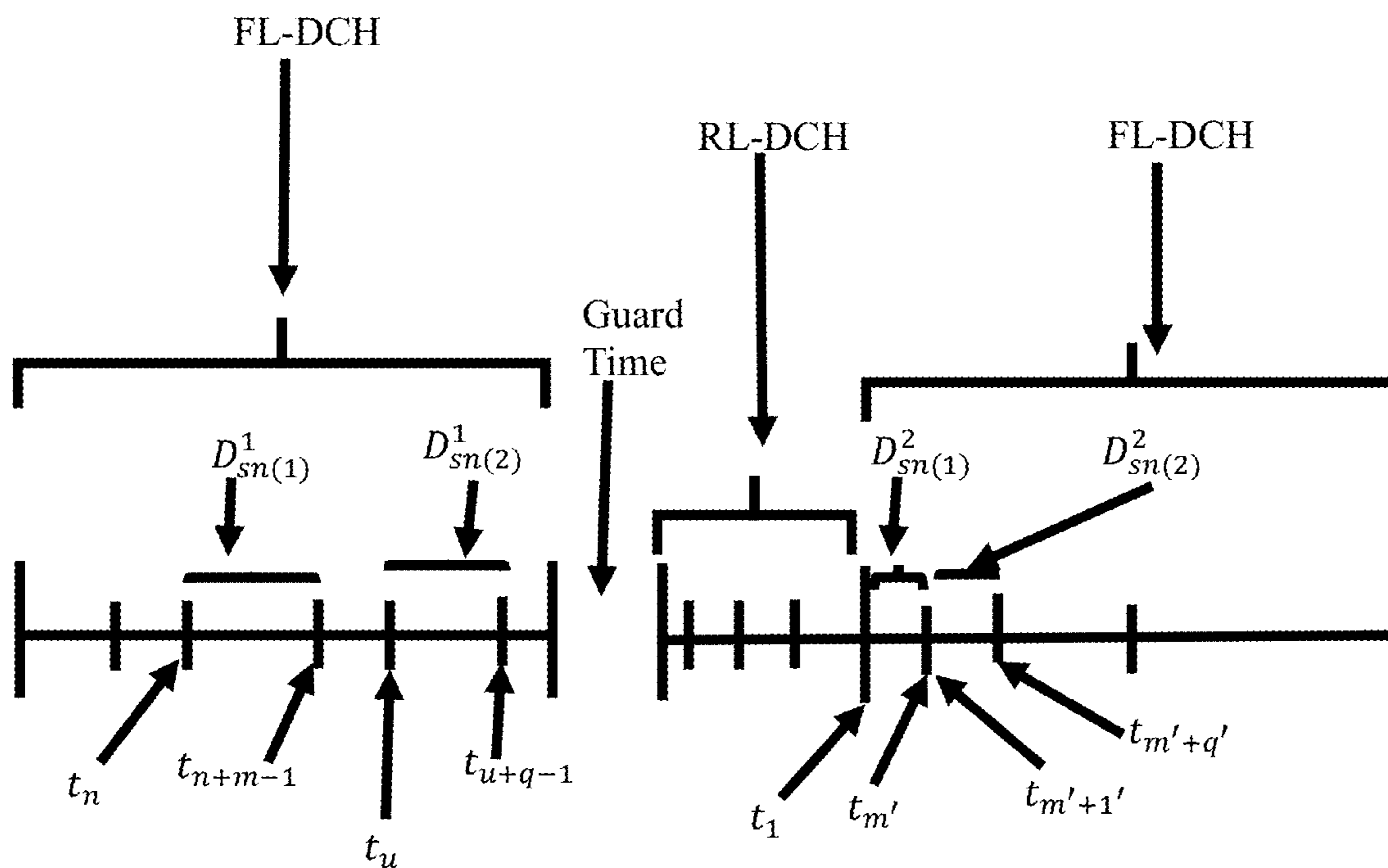

FIG. 4D

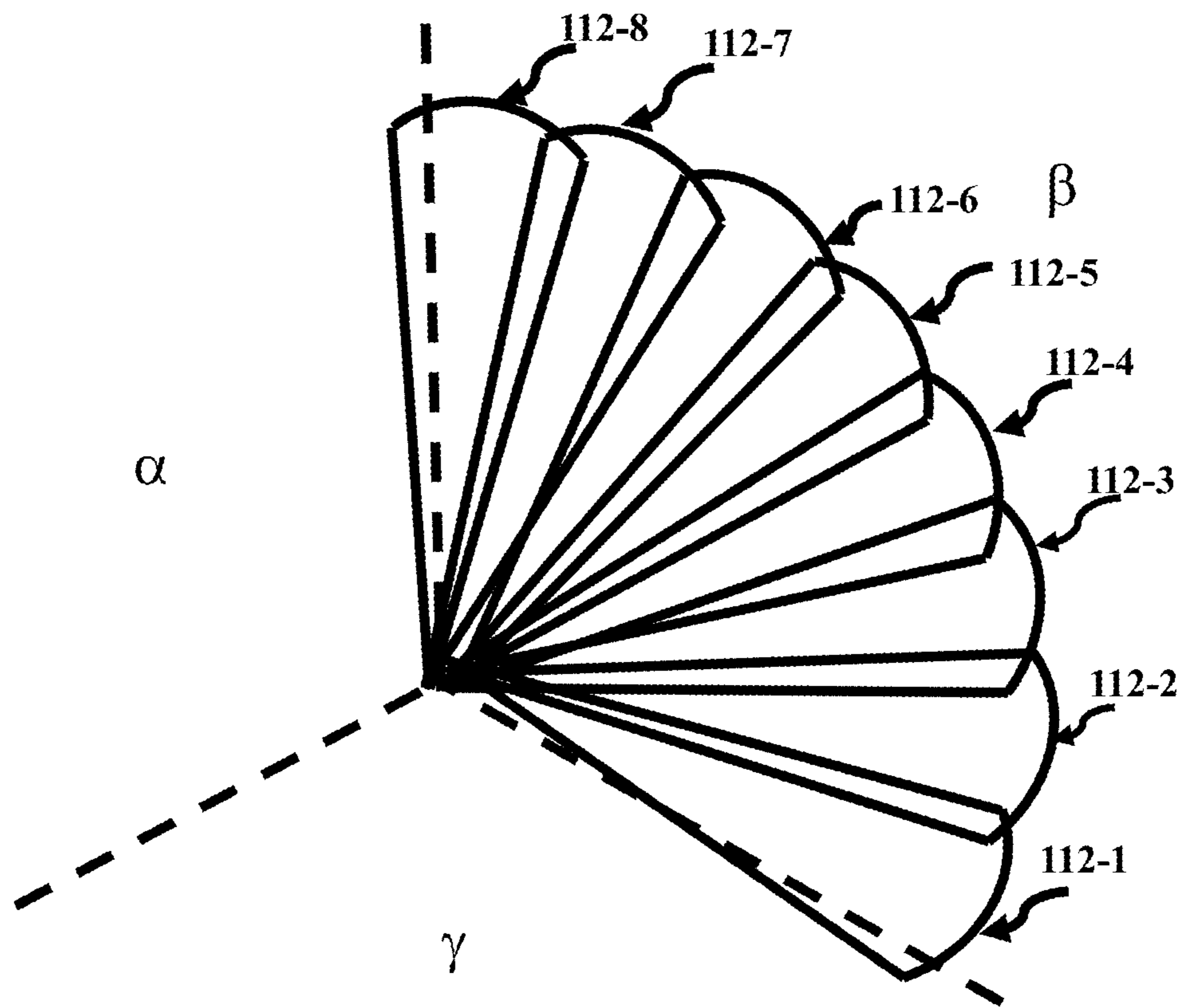

FIG. 5A

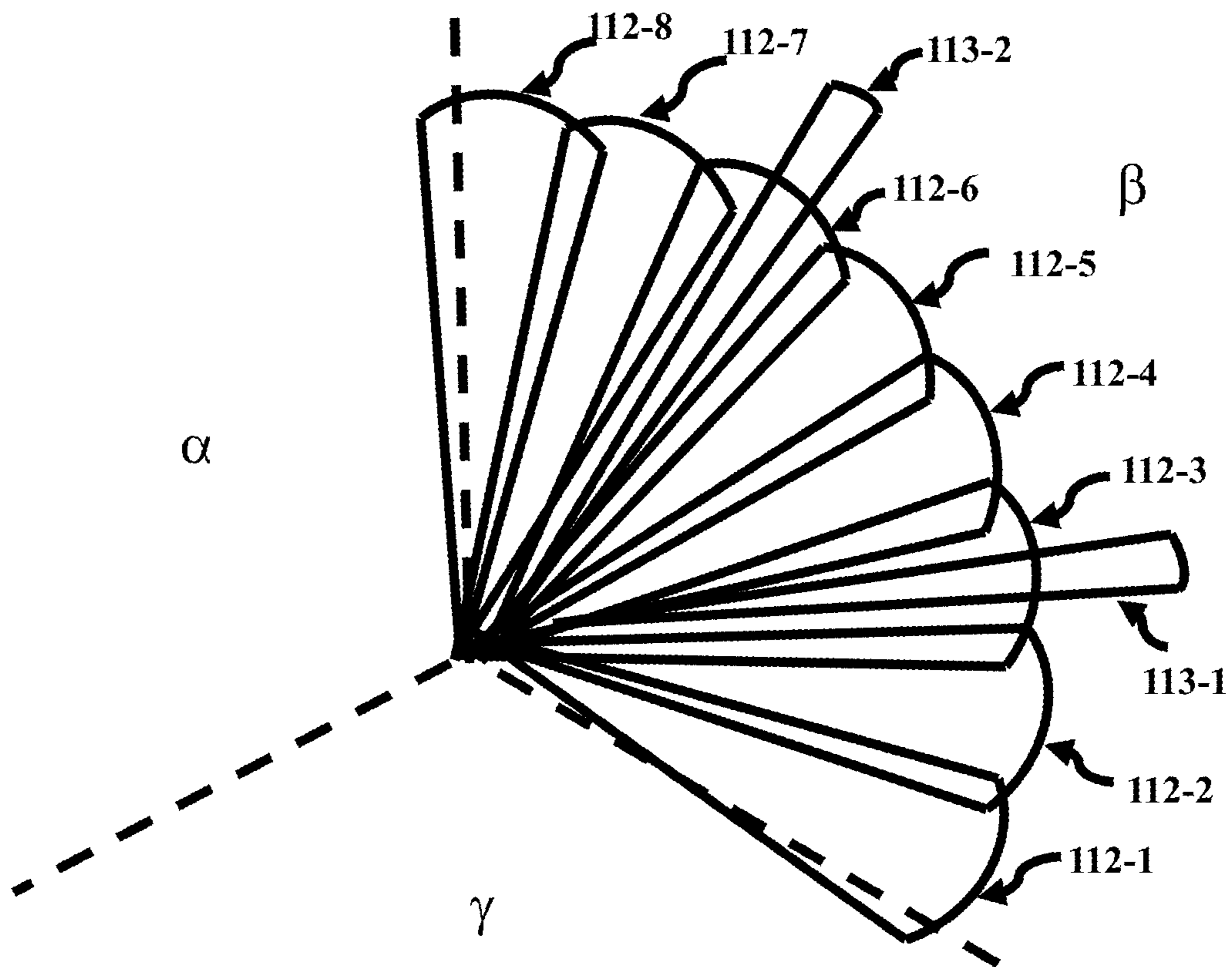

FIG. 5B

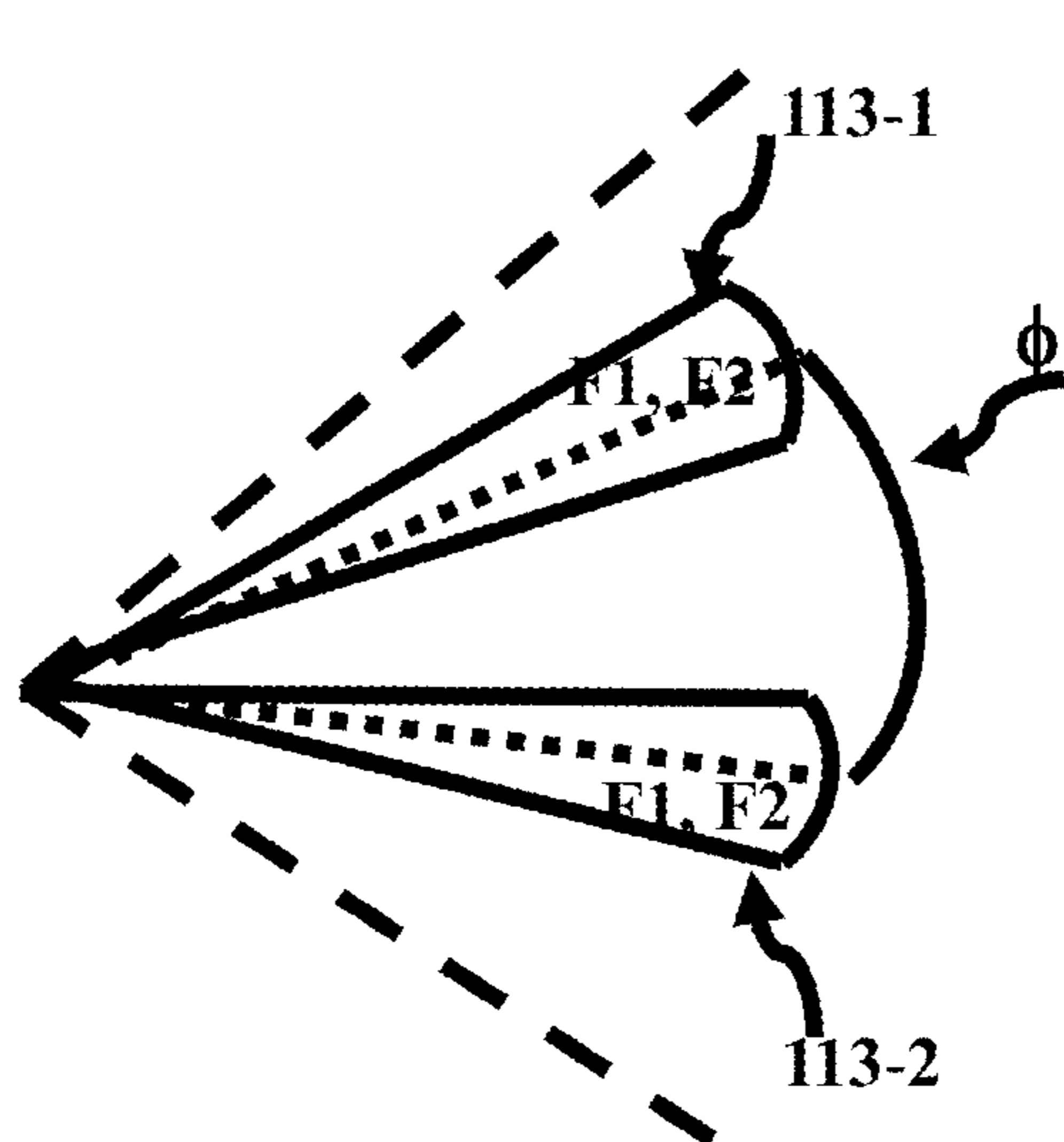

FIG. 6A

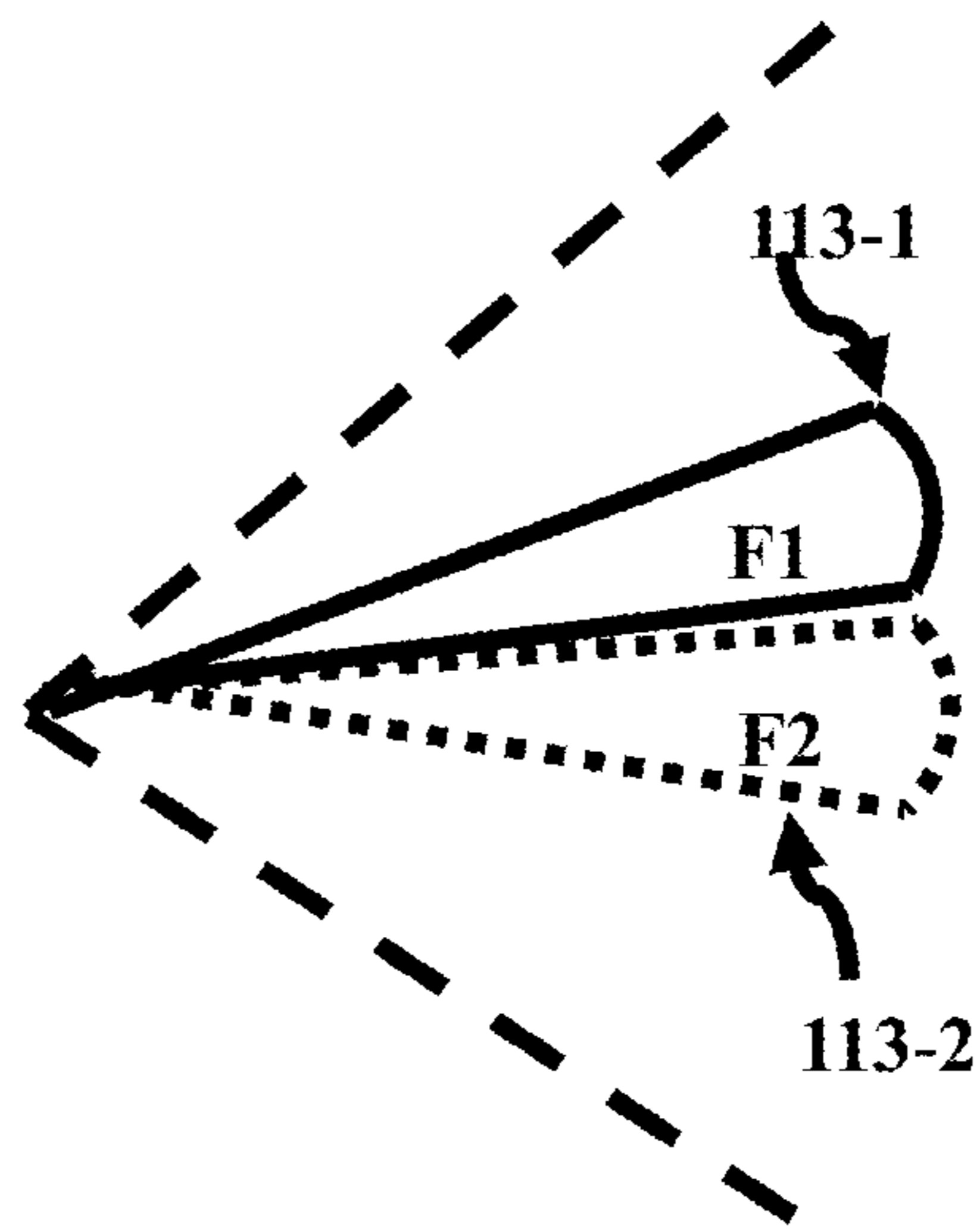

FIG. 6B

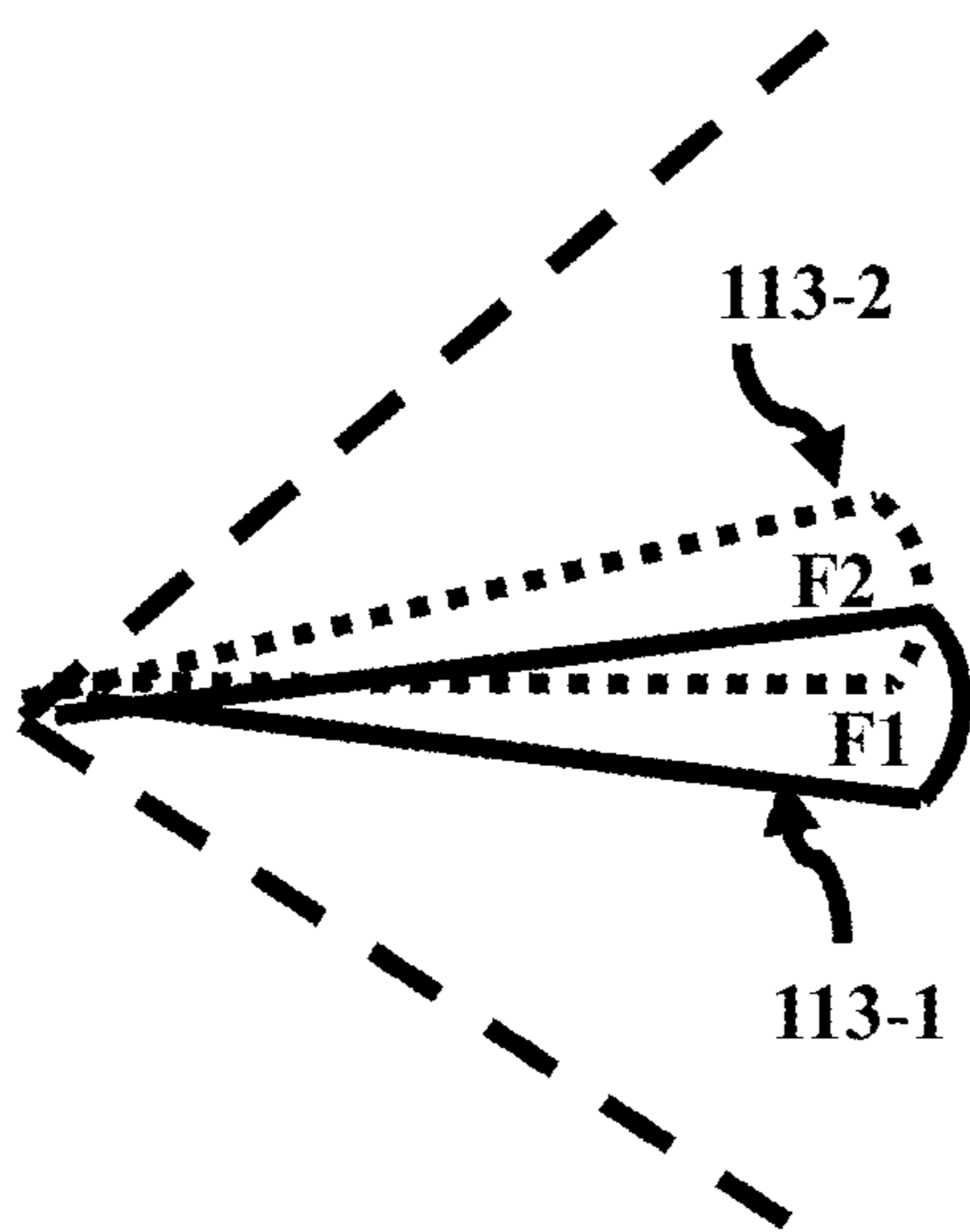

FIG. 6C

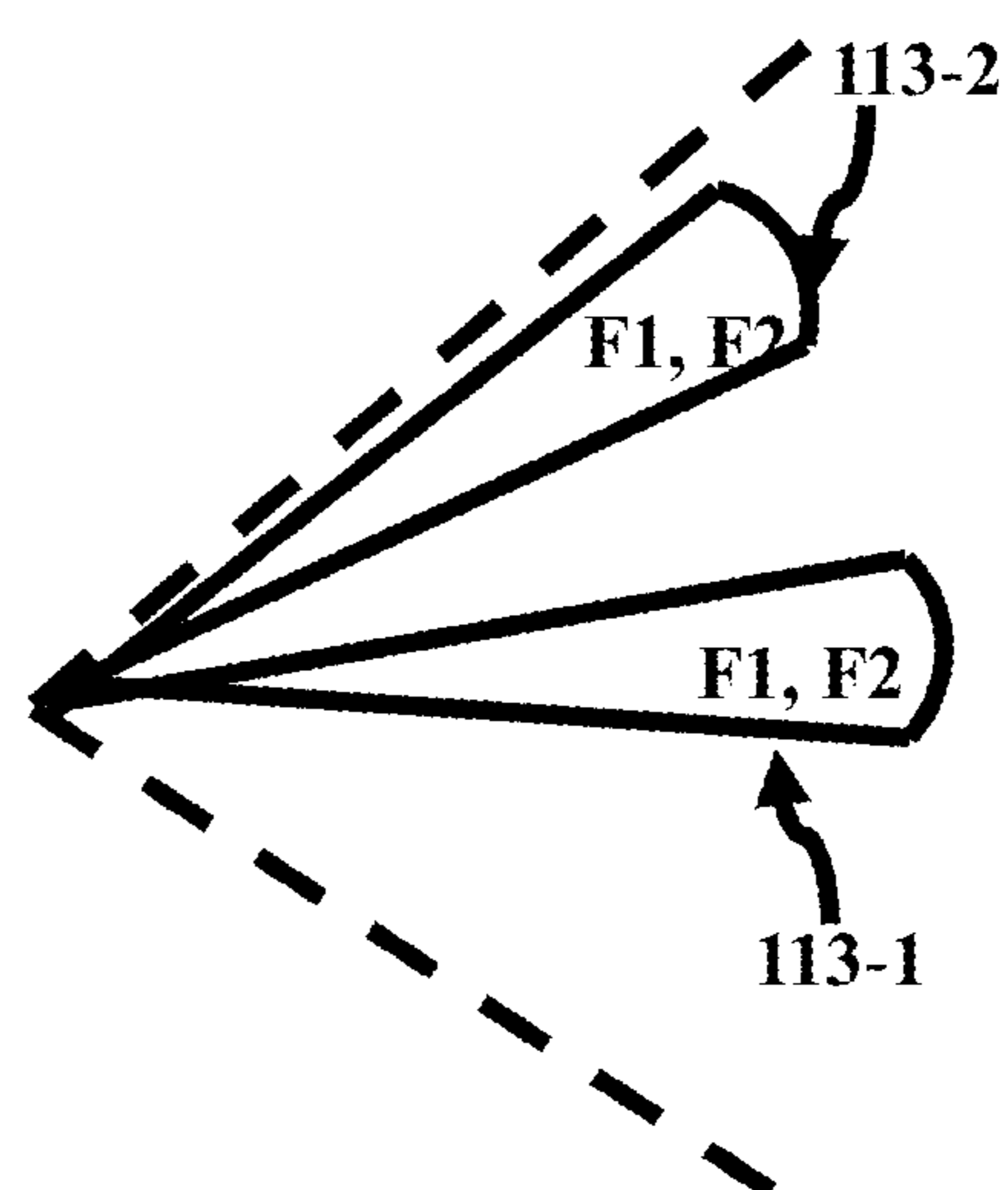

FIG. 6D

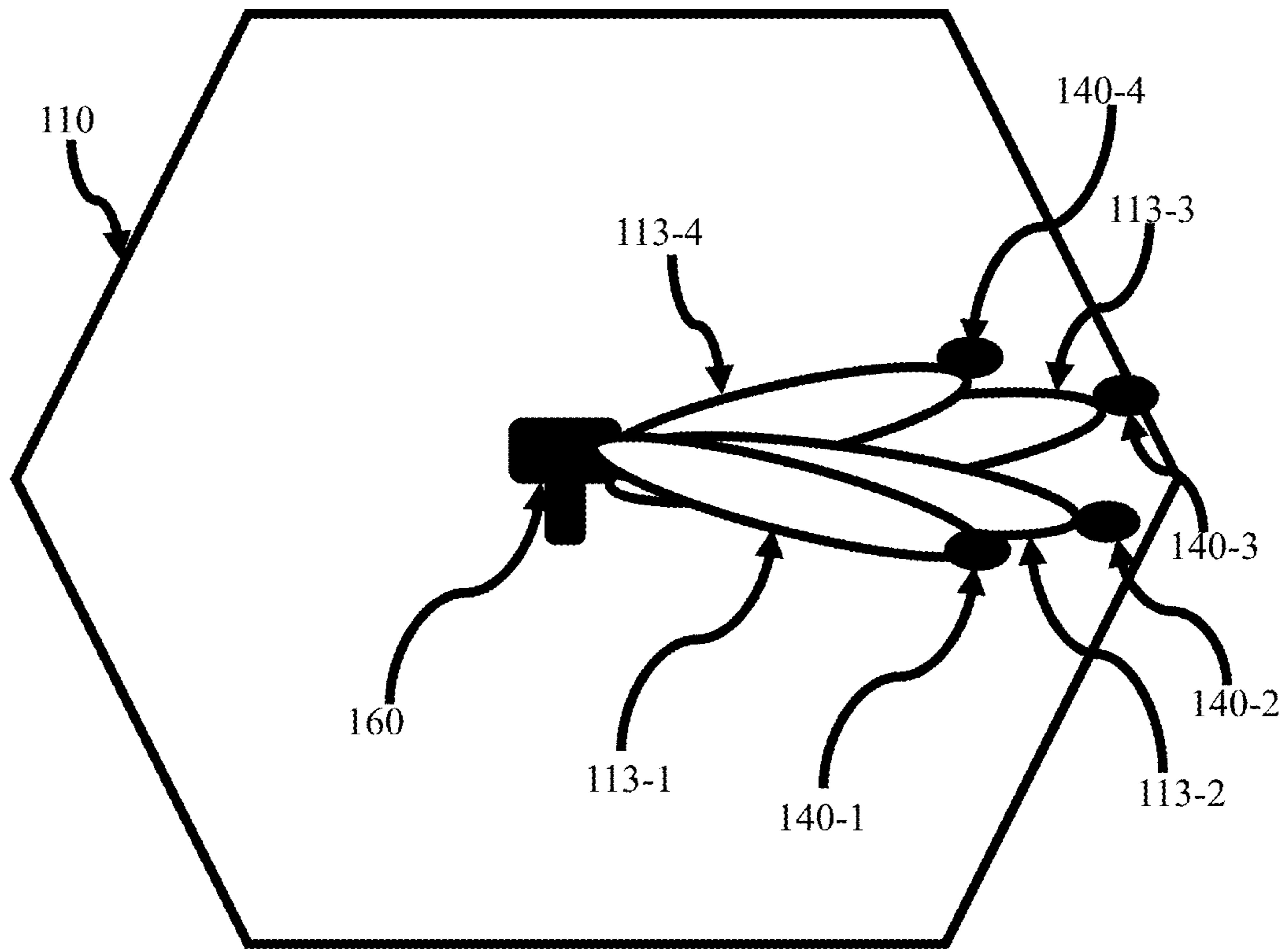

FIG. 7A

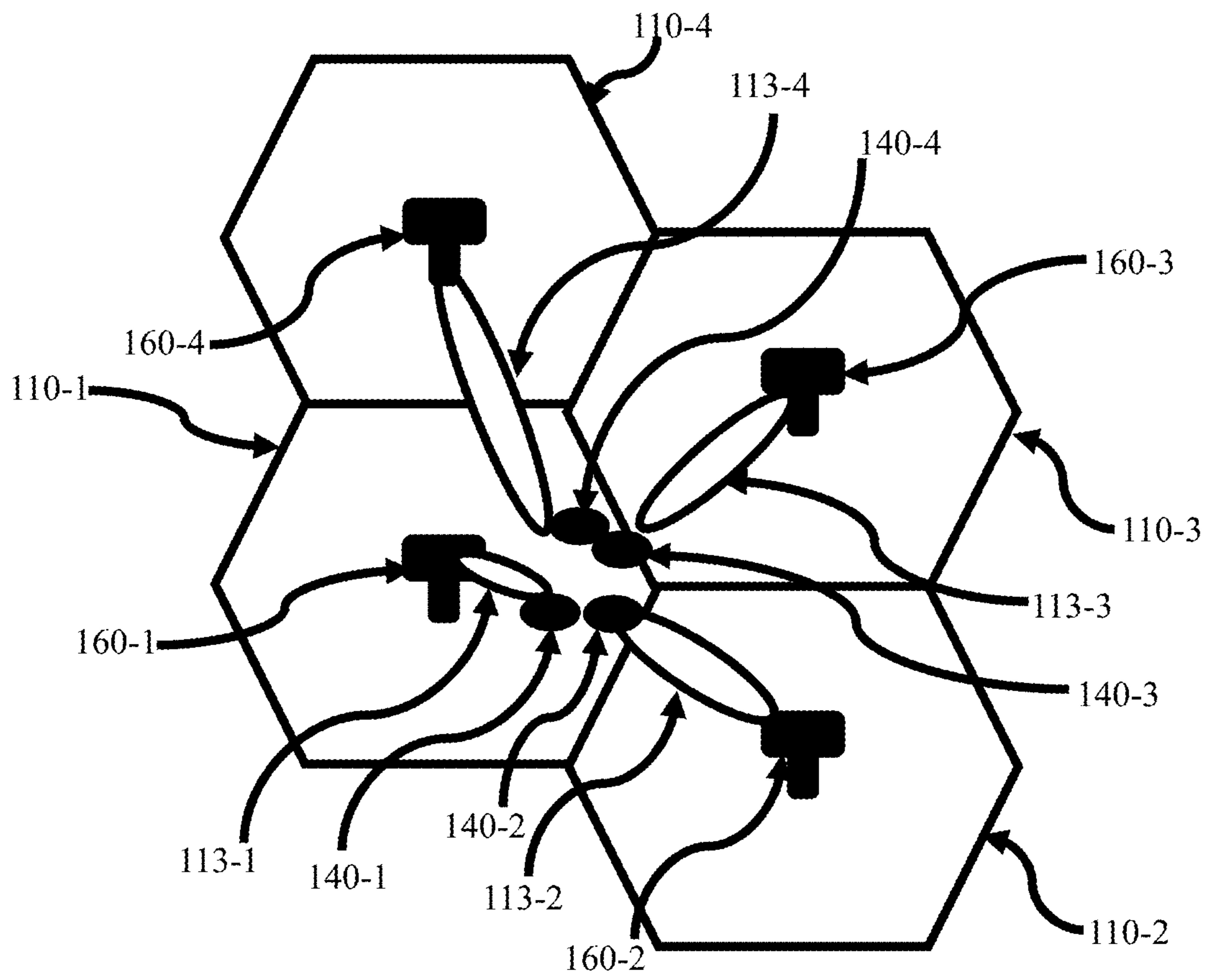

FIG. 7B

AIR TO GROUND NETWORK FOR BROADBAND ACCESS TO AERIAL PLATFORMS

CROSS-REFERENCE

This application claims priority to co-owned and co-pending U.S. Utility application Ser. No. 15/906,483 filed Feb. 27, 2018 entitled: "WIRELESS COMMUNICATIONS SYSTEM FOR BROADBAND ACCESS TO AERIAL PLATFORMS", U.S. Utility application Ser. No. 15/897,018 filed Feb. 14, 2018 entitled: "COMMUNICATIONS SYSTEM FOR PROVIDING BROADBAND ACCESS TO AERIAL PLATFORMS", and U.S. Provisional Application Ser. No. 62/593,754 filed Dec. 1, 2017 entitled: "A WIRELESS COMMUNICATIONS SYSTEM FOR BROADBAND ACCESS TO AERIAL PLATFORMS", the contents of which are incorporated by reference in their entirety. This application is a continuation in part of U.S. Utility application Ser. No. 15/906,483 filed Feb. 27, 2018 entitled: "WIRELESS COMMUNICATIONS SYSTEM FOR BROADBAND ACCESS TO AERIAL PLATFORMS".

COPYRIGHT

A portion of the disclosure of this patent document contains material that is subject to copyright protection. The copyright owner has no objection to the facsimile reproduction by anyone of the patent document or the patent disclosure, as it appears in the Patent and Trademark Office patent files or records, but otherwise reserves all copyright rights whatsoever.

FIELD OF THE INVENTION

The present disclosure describes aspects of a system comprising of a network of terrestrial cell sites for broadband internet access to aerial platforms such as drones, general aviation, and commercial aircraft. The present disclosure describes systems and methods for the design of communications protocols between cell sites and aerial platforms, steering of the cell site antenna beams toward the aerial platforms, design and pointing of the aerial platform antenna beams toward the cell sites, assignment of aerial platforms to cell sites, and cell site sectorization.

BACKGROUND OF THE INVENTION

Broadband internet access to aerial platforms such as low altitude drones flying at an altitude of about 400 feet, and general aviation and commercial aircraft flying at altitudes of as high as 50,000 feet, has in recent years been of great interest. Two different approaches to providing broadband internet access to aircraft have been: a network of ground cell sites referred to as ATG (Air to Ground); satellite based aeronautical broadband access systems.

Communications systems using GSOs (Geo-Stationary Satellites) can provide ubiquitous internet access to aircraft over land as well as water. However, satellite-based systems are expensive means of providing broadband access to aircraft. ATG systems are a less expensive means of providing broadband access for aircraft flying over land. To provide ubiquitous and cost efficient broadband access to aircraft over land and oceans, a hybrid system consisting of a cost efficient ATG system for coverage over land, combined with a satellite-based system for coverage over water, is one candidate solution.

A well-known ATG system is the network of cell sites that is deployed and operated by Gogo in the 800 MHz band, and covers the CONUS (Continental US). This system has access only to 4 MHz of spectrum; this small amount of spectrum limits the data rate to each aircraft and the overall network throughput. In order to provide a high data rate and high throughput ATG system, larger amount of spectrum is needed. However, it is also important that the spectrum be inexpensive. Licensed spectrum that is usable for broadband access to smartphones and other consumer devices is too expensive to be used for ATG systems. Therefore, an inexpensive source of spectrum is needed for ATG systems.

There is a large amount of spectrum in frequency bands above 3 GHz. One source of spectrum for ATG service is the 5 GHz unlicensed band, specifically the so called UNII-1 (5.15 to 5.25 GHz) and UNII-3 (5.725 to 5.85 GHz) bands. The obvious benefit of using the unlicensed bands is that they do not require any license fees. However, since the spectrum is being used by multiple systems, techniques must be devised to mitigate interference from other systems into the ATG system, while meeting the FCC imposed EIRP (Effective Isotropic Radiated Power) limits in the unlicensed bands. There are also other sources of spectrum above 5 GHz such as the C band, or even higher bands, where an ATG system may be able to share the spectrum with another service. Signal attenuation due to propagation path loss and other atmospheric effects are high in higher frequencies, and techniques are required to mitigate these effects. Moreover, the objective is to provide very high data rates to the aircraft, similar to the data rates to which people are accustomed at home. Therefore, system and methods are required to develop a high throughput system specifically optimized for aerial platforms.

BRIEF DESCRIPTION OF THE SEVERAL VIEWS OF THE DRAWINGS

Some embodiments of the present invention are illustrated as an example, and are not limited by the accompanying figures. In the following figures, where appropriate, similar components are identified using the same reference label.

FIG. 1 illustrates an exemplary diagram of a network of cell sites for providing broadband internet access to aerial platforms of some embodiments.

FIGS. 2A and 2B illustrate exemplary block diagrams of communications equipment at the sector of a cell site, according to some embodiments.

FIG. 2C illustrates an exemplary block diagram of a cell site radio module, according to some embodiments.

FIG. 2D illustrates an exemplary block diagram of communications equipment at the sector of a cell site, according to some embodiments.

FIGS. 3A, 3B, 3C and 3D illustrate exemplary block diagrams of the communications equipment of the aerial platforms, according to some embodiments.

FIGS. 4A, 4B, 4C and 4D illustrate exemplary frame structures for the communications protocol according to some embodiments.

FIGS. 5A and 5B illustrate exemplary diagrams of sectorization and beam coverage, according to some embodiments.

FIGS. 6A, 6B, 6C, and 6D illustrate exemplary diagrams of cell site beam positions and frequency reuse pattern, according to some embodiments.

FIGS. 7A and 7B illustrate exemplary diagrams of cell site beam assignment to aerial platforms, according to some embodiments.

SUMMARY

A system to provide broadband access to aerial platforms is described. The system comprising: a network of cell sites, each cell site composed of at least one sector, each sector is equipped with a sector communications equipment comprising a processor sub-system, L cell site radio modules and L antenna apertures, where L is an integer larger than 1; each antenna aperture configured to form at least one steerable beam per sector; each cell site radio module configured to transmit on only one antenna aperture and to receive from all L antenna apertures in the sector. The system further comprising: a plurality of aerial platforms that each comprise an aerial platform communications equipment comprising a radio sub-system and an antenna sub-system, the antenna sub-system comprising at least one antenna aperture forming at least one steerable beam.

In some embodiments the communications equipment is configured to: divide each of N, an integer, data packet streams destined to N different aerial platforms into L data packet sub-streams; and transmit each of the L data packet sub-streams corresponding to an aerial platform on a different antenna aperture using a different polarization or a frequency channel. In some embodiments, the available spectrum is divided into L frequency channels. In some embodiments, each antenna aperture comprises of two polarizations and both polarizations of each antenna aperture are used for data transmission.

In one embodiment, L is an even integer, a first polarization of a first half of the antenna apertures and a second polarization of a second half of the antenna apertures are used for data transmission, the available spectrum is divided into L/2 frequency channels, the data packet stream destined for an aerial platform is divided into L sub-streams, a first half of the data packet sub-streams are sent on the first polarization using a different frequency channel on each antenna aperture, and the second half of the data packet sub-streams are sent on the second polarization using a different frequency channel on each antenna aperture.

In one embodiment of the sector communications equipment, the baseband modem encodes and modulates a data packet to generate a digital IQ sample stream, the beamformer generates a plurality of beamforming digital IQ sample streams, one for each antenna element of each antenna aperture, and sends each beamforming digital IQ sample stream to an antenna element of an antenna aperture.

In some embodiments, the aerial platform communications equipment is further configured to: receive a data packet stream from upper layer protocols; split the data packet stream into multiple data packet sub-streams; and transmit each data packet sub-stream on a different antenna polarization or a different frequency channel. In some embodiments, the sector communications equipment is further configured to: receive an RF signal from each antenna element of each antenna aperture; generate a digital IQ sample stream from the received RF signal; send the digital IQ sample streams corresponding to a frequency channel and antenna polarization to a specific radio module; combine the digital IQ sample streams at each radio module into a single digital IQ sample stream, demodulate and decode the single digital IQ sample stream to recover the data packet sub-stream; and combine all data packet sub-streams into a single data packet stream. In a variation of the embodiment,

the digital IQ sample streams are combined such as to maximize a signal quality metric for the single digital IQ sample stream. In another variation of the embodiment, the signal quality metric is received SINR.

In some embodiments, the sector communications equipment is configured to: divide the sector coverage area into a number of sub-sectors and form a beam to cover each sub-sector. In some embodiments, the aerial platform communications equipment is configured to: form a beam toward a first sub-sector beam; measure a signal quality metric on the first sub-sector beam and on a second sub-sector beam adjacent to the first sub-sector beam; and point the beam toward the second sub-sector beam if the signal quality metric on the second sub-sector beam is higher than the signal quality metric on the first sub-sector beam.

Some embodiments describe an aerial platform apparatus comprising: at least two main modules, a communications module and at least one remote antenna module; the communications module comprising at least one radio sub-system and an antenna sub-system comprising at least three antenna apertures; the radio sub-system comprising an RF transceiver, a beamformer, a baseband modem and a processor. The remote antenna module comprising an RF transceiver and an antenna sub-system comprising at least three antenna apertures. A communications interface transfers digital IQ sample streams between the remote antenna module and the communications module. The remote antenna module is configured to: receive an RF signal from each antenna element of an antenna aperture; convert the RF signal to a digital IQ sample stream; and send the digital IQ sample stream to the communications module over the communications interface. The communications module is configured to: generate a digital IQ sample stream for each RF signal received from each antenna element of an antenna aperture for a frequency channel and an antenna polarization; receive a digital IQ sample stream from at least one remote antenna module for the corresponding frequency channel or antenna polarization; combine the digital IQ sample streams to form a single digital IQ sample stream; and demodulate and decode the single digital IQ sample stream to decode a data packet stream. In some embodiments, the communications module is further configured to: decode at least two data packet streams, each stream on a different frequency channel or antenna polarization; and combine the data packet streams to form a single data packet stream.

In one embodiment of the aerial platform communications module apparatus, the processor splits a data packet stream into at least two data packet sub-streams, the baseband modem encodes and modulates each data packet sub-stream and generates a digital IQ sample stream for each data packet sub-stream, the beamformer generates, for each digital IQ sample stream received from the baseband modem, a first plurality of beamforming digital IQ sample streams for antenna elements of an antenna aperture of the communications module and a second plurality of beamforming digital IQ sample streams for antenna elements of an antenna aperture of the remote radio module, and sends the second plurality of beamforming digital IQ sample streams to the remote antenna module. The remote antenna module generates an RF signal for each digital IQ sample stream by upbanding onto a frequency channel, and transmits each RF signal on an antenna element of the remote antenna module antenna aperture. Similarly, the aerial platform communications equipment generates an RF signal for each digital IQ sample stream by upbanding onto a frequency channel, and

transmits each RF signal on an antenna element of a communications module antenna aperture.

DETAILED DESCRIPTION OF THE INVENTION

The following detailed description is of the best currently contemplated modes of carrying out exemplary embodiments of the invention. The description is not to be taken in a limiting sense, but is made merely for the purpose of illustrating the general principles of the invention, as the scope of the invention is best defined by the appended claims.

Various inventive features are described below that can each be used independently of one another, or in combination with other features. Broadly, some embodiments of the present invention generally provide a way to communicate among a set of aerial platforms and a set of ground cell sites.

The present disclosure describes aspects of a system designed to provide broadband access to aerial platforms. Such aerial platforms may include, for instance, drones, UAVs, balloons, blimps, airships, general aviation, and commercial aircraft etc.

FIG. 1 illustrates an exemplary ground coverage area **100** divided into a contiguous set of smaller conceptual hexagonal coverage areas **110-j**, and a cell site equipment **160-j** in each coverage area, *j* an integer index identifying different coverage areas and different cell site equipment of the same type. The network of cell sites and cell site equipment of FIG. 1 provide connectivity to aerial platforms **140-i**, *i* an integer index identifying different aerial platforms of the same type. In the exemplary illustration of FIG. 1, the dotted lines in each cell coverage area **110-j** divide the cell area into six conceptual triangular areas **112**, referred to as sectors. The reason for dividing the cell coverage area **110** into multiple smaller sectors **112** is to increase the overall network data throughput, and the number of aerial platforms that communicate with the cell site. Note that the cell coverage area may be divided into any number of sectors, 2, 3, 4 or more. The example of 6 sectors is used only for illustration purposes, a person of ordinary skill in the art will readily recognize that number of sectors other than 6 may be used without departing from the scope of the disclosure.

Cell Site Apparatus

FIG. 2A illustrates one exemplary embodiment of the cell site sector equipment **190** of one sector of a cell site. In the exemplary example of FIG. 1, where each cell site coverage area is divided into 6 sectors, there are 6 instantiations of cell site sector equipment **190** providing connectivity to aerial platforms in the corresponding sectors, comprising the cell site equipment **160**. The cell site sector equipment **190** comprises two main sub-systems, the antenna sub-system **120**, and the radio sub-system **130**. The exemplary antenna sub-system **120** depicted in FIG. 2A is a panel composed of *M* antenna elements **122-j**, *j* an integer index identifying different elements of the same type. The signals that are applied to the different elements **122-j** of the antenna sub-system **120** are phased in such a way as to shape the antenna beam according to a desired pattern, and to point the peak of the beam in azimuth and in elevation toward a given aerial platform.

Some examples of the cell site antenna beam pattern shaping requirements are described next. There are two main signal paths from the aerial platform to the cell site, the line of sight signal path, and the reflection from the ground also referred to as the specular reflection. The line of sight and specular reflection may—depending on factors such as the

distance between the transmitter and receiver, height of the cell site and drone antennas and the ground reflection coefficients—add destructively and cause fading to the signal at the receiver. One solution to mitigating fading due to ground reflection is to reduce the cell site antenna gain below horizon so that the ground reflection is attenuated. Furthermore, the cell site antenna gain toward the ground, i.e. below horizon, should be designed to be low in order to minimize interference to other devices that may be using the same frequency band on the ground. Therefore, one requirement is that the cell site antenna pattern be shaped to have low gain below horizon. Since the aerial platforms fly well above the horizon with respect to the cell sites, the cell site antenna gain above horizon determines the quality of communications link to the aerial platform. As the aerial platform distance from the cell site increases, the signal attenuation due to path loss also increases. Therefore, the cell site antenna gain needs to increase at larger distances, as the elevation angle from the cell site toward the aerial platform decreases, in order to compensate for the additional path loss. A cell site antenna pattern whose gain pattern above horizon at different locations from the cell site is shaped such as to compensate for the difference in the path loss at the corresponding locations, is said to have isoflux property. Therefore, the different antenna elements **122-j** of the antenna sub-system **120** are ideally phased to provide low gain below horizon, have approximate isoflux property above horizon over at least a certain range of elevation angles, and point the peak of the beam toward a given angular position in azimuth and elevation.

The cell site sector equipment radio sub-system **130**, as depicted in FIG. 2A, comprises: an RF transceiver **132** that converts the baseband signal to RF frequency of operation; a beamformer sub-system **134** that determines the phases that need to be applied to signals destined to each antenna element to generate the beams for each sector; a baseband sub-system **136** that carries out baseband signal processing functions such as error correction encoding and decoding, modulation, and demodulation; and a processor sub-system **138** to implement functions such as upper layer protocols, assignment of radio resources such as cell site beams, frequency channels and time slots on each channel to aerial platforms, sector beam management, mobility management, and security features. The interface **122** between the baseband sub-system **136** and the beamformer sub-system **134** comprises of *N* streams of IQ samples, each stream corresponding to a one of the *N* data streams to be transmitted on the *N* beams formed by one antenna sub-system corresponding to one sector. In one embodiment, the baseband sub-system comprises of *N* baseband modems whereby each modem encodes the information for one cell site to aerial platform communication link using an error correction code, modulates the encoded data onto constellation symbols, and generates the IQ samples to be further processed by the beamformer sub-system. The interface **123** between the beamformer sub-system **134** and the RF transceiver sub-system **132** comprises of *M* streams of IQ samples, *M* being the number of antenna elements of the antenna aperture for one sector. In one embodiment, the beamformer sub-system generates *M* IQ sample streams according to

$$c_j(n) = \sum_{i=1}^N d_i(n) \alpha_{ij} \quad (1a)$$

where $d_i(n)$ is the encoded modulation symbols corresponding to the *i*-th data stream ($1 < i < N$), *n* is the sampling time index, and α_{ij} ($1 < j < M$) is the complex beamforming coefficients for the *i*-th beam corresponding to the *i*-th data stream. The beam former uses the coefficients α_{ij} computed by the

processor sub-system to generate and send the IQ sample streams $c_1(n)$ ($1 < j < M$) to the RF transceiver sub-system, where each stream is further modulated by the RF transceiver sub-system onto the carrier frequency and sent to one of the M antenna elements.

In one embodiment, the beamformer sub-system and the RF transceiver are co-located with the antenna sub-system. In another embodiment, the beamformer sub-system is co-located with the baseband sub-system, and the RF transceiver is co-located with the antenna sub-system. In one embodiment, the RF transceiver **132** is interfaced with the antenna elements using an RF interface **124** comprising of M RF signals, each signal sent to one of the M antenna elements. In another embodiment, the RF transceiver is implemented in a distributed manner whereby the IQ sample stream destined to a given antenna element is modulated onto the carrier frequency by an RF transceiver next to the said antenna element. The cell site sector equipment **190** is connected to the Network Controller (NC) sub-system **180** via network **170**. The NC **180** coordinates activities such as handoff of aerial platforms from one cell site to another, sends configuration parameters to aerial platforms, configures the cell site equipment parameters, and implements network wide assignment of radio resources to aerial platforms as will be further discussed in the remainder of this disclosure. Note that the NC may alternatively be collocated with one of the cell sites, or be implemented by cell site equipment of one of the cell sites as long as NC has connectivity to other network elements for exchange of information.

The fading due to ground reflection described above is a function of the distance between the transmitter and the receiver, height of the aerial platform and cell sites antennas, and properties of the ground where reflection occurs. At some distances between the transmitter and the receiver, the line of sight and ground reflection signals even add constructively resulting in a stronger combined signal at the receiver. For the same transmitter and receiver distance, at some cell site antenna heights the signals may even add constructively. Therefore, it is advantageous to include multiple antenna apertures at the cell site to create diversity to help mitigate ground reflection induced fading. FIG. 2B illustrates a cell site sector equipment comprised of two antenna sub-systems **120-1** and **120-2**, connected to the radio sub-system **130** via interfaces **124-1** and **124-2**. A first antenna sub-system **120-1** is placed above the second antenna sub-system **120-2**. In one embodiment, the cell site radio sub-system **130** estimates the signal quality received on the two antenna apertures from the aerial platform, and chooses the antenna aperture with stronger signal for communications with the aerial platform. In another embodiment, the cell site radio sub-system combines the signals from the two antennas using baseband signal processing techniques such as maximal ratio or maximum likelihood combining and uses the combined signal for demodulation.

The ground reflection induced fading is also present at the aerial platform receiver. If at a given time the cell site antenna is in a fade due to ground reflection, the aerial platform antenna may also be in fade. Also, even if at a given time the cell site antenna is not in fade, the aerial platform antenna may be in fade because of potentially different hardware induced delays on the cell site to aerial platform and aerial platform to cell site links, or if the cell site to aerial platform and aerial platform to cell site links use different frequency channels. Therefore, a mechanism is also needed to mitigate fading at the aerial platform antenna. In one embodiment, the cell site radio sub-system transmits to the

aerial platform on the cell site antenna aperture from which it receives the highest signal power from the aerial platform. In another embodiment, the cell site radio sub-system sequentially transmits reference signals to the aerial platform on the two antennas where the reference signals identify what antenna they are sent on; the aerial platform radio sub-system estimates the signal strength received on each of the two reference signal transmissions from the cell site, and informs the cell site radio sub-system on which reference signal it receives a stronger signal. The cell site radio sub-system transmits to the aerial platform on the antenna aperture that the aerial platform receives a stronger signal. In another embodiment, the cell site radio sub-systems transmit to the aerial platform on both antennas by phasing the transmit signals on the two antennas such that the signals are in phase and add constructively at the aerial platform receiver. FIG. 2B, and the above description considered two antennas at the cell site. However, a person of ordinary skill in the art will readily recognize that the embodiments described in this disclosure can be described in conjunction with more than two antenna apertures without departing from the scope of the disclosure.

In one embodiment, the beamformer sub-system carries out the beam forming function digitally by applying appropriate phases to baseband signals destined to different antenna elements to form the desired beams in the sector. In another embodiment, the beamformer determines the phases for each antenna element to achieve the specified beam pattern, but the phases are applied at RF stage by the RF transceiver **132** or by the circuitries that are part of the antenna elements **122-j**. The interface between the RF transceiver and the antenna elements is shown by RF interface sub-system **124**. As will be described later in this disclosure, the beamformer **134**, the RF transceiver **132** and the antenna sub-system **120** may form multiple simultaneous beams, with each beam pointing in a different direction toward different aerial platforms.

FIG. 2C illustrates an exemplary cell site radio module **200** comprising an RF transmitter sub-system **232**, an RF receiver sub-system **233**, a transmit beamformer **234**, a receive beamformer **235**, a baseband modem **236**, a processor **238**, a transmit RF interface **224** and receive RF interfaces **223-i**, i an integer identifying different interfaces of the same type. The transmit RF interface **224** carries M RF signals to the M different antenna elements of an antenna aperture interfaced to the RF transmitter **232**. As illustrated in FIG. 2C, the cell site radio module **200** comprises of L, an integer, receive RF interfaces of the type **223**, namely **223-1** to **223-L**, each interface carrying M RF signals received from an antenna aperture. The baseband modem **236** and processor **238** sub-systems of the apparatus of FIG. 2C have the same functionality as the baseband modem **136** and processor **138** sub-systems described in conjunction with embodiments of FIGS. 2A and 2B. The transmit beamformer **234** receives N streams of digital IQ samples from the baseband modem **236**, each stream corresponding to data packets destined to an aerial platform, and creates M different streams of IQ samples by applying different beamforming coefficients to the N received IQ sample streams and interfaces the M IQ sample streams to the RF transmitter sub-system **232**. Equation (1a) illustrates a mathematical formulation of an exemplary digital transmit beamforming which computes the M IQ sample streams. The RF transmitter **232** upbands the M IQ sample streams to the frequency carrier of operation, amplifies each signal and interfaces each RF signal to one antenna element of an antenna aperture. The beamforming coefficients applied to the N data

digital IQ sample streams received from the baseband modem are determined so that the antenna aperture forms N beams toward specific angular positions within each sector, each beam carrying data packets corresponding to one of the N data digital IQ streams received from the baseband modem.

The RF receiver illustrated in FIG. 2C comprises of L interfaces of the type 223, each interface 223-*i* is connected to one of L antenna apertures and receives M RF signals, one RF signal received from one antenna element of the *i*-th antenna aperture. RF receiver 233 downconverts the ML (M times L) received RF signals corresponding to a frequency channel to ML baseband digital IQ sample streams and sends the IQ sample streams to the receive beamformer. For each of the N transmitted data streams, the receive beamformer combines the ML digital IQ samples, corresponding to the frequency channel and antenna polarization on which the data packet is transmitted, at each sampling time instant to generate a single digital IQ sample stream while maximizing a certain signal quality metric such as the received SINR (Signal to Interference plus Noise Ratio). The baseband modem demodulates and decodes the combined digital IQ sample streams to recover the transmitted data packets. In one embodiment, the receive beamformer chooses the receive beamforming coefficients, where integer index *i* identifies the *i*-th received digital IQ sample stream and integer index *j* identifies the *j*-th data stream transmitted from the *j*-th aerial platform, and computes one combined digital IQ sample stream for each of the N data streams, $r_j(n)$, at sampling time index *n* according to

$$r_j(n) = \sum_{i=1}^{LM} s_i(n) \beta_{ij} \quad (1b)$$

such as to maximize a signal quality metric such as the received SINR on each combined IQ sample stream $r_j(n)$.

In one embodiment, FIG. 2D illustrates an exemplary cell site sector communication equipment 190 comprising an antenna sub-system 120 and L cell site radio modules 200-1-200-L, the antenna sub-system comprising L antenna apertures 121-1-121-L, where L is an integer greater than 1. In one embodiment, each of the L antenna apertures is placed above another antenna aperture at the cell site sector. As discussed in a previous embodiment, each cell site radio module generates N data streams where each stream is destined to an aerial platform, determines M transmit beamforming coefficients and generates M RF signals as described in the previous embodiments, each signal sent to one antenna element of an antenna aperture to form N beams toward different angular directions. As illustrated in FIG. 2D, the *i*-th cell site radio module ($1 < i < L$) transmitter is interfaced to the *i*-th antenna aperture 121-*i*. The *i*-th cell site radio module receiver is interfaced to all antenna apertures and, as discussed in conjunction with equation (2b), combines the received signals from all antenna apertures to decode the data streams transmitted by the aerial platforms on one or more frequency channels and one or two antenna polarizations and are destined to the *i*-th cell site radio module. Therefore, the communications equipment of FIG. 2D generates LN (L times N) beams within a sector and transmits/receives data to/from N aerial platforms. In one variation of the embodiment, each antenna aperture 121-*i* comprises of two antenna polarizations. In another variation of the embodiment, each antenna aperture has one polarization but one set of the antenna apertures use one antenna polarization and the remaining antenna apertures use another polarization.

In one embodiment, the processor sub-system of cell site communications equipment splits the data packet stream

received from upper layer protocols to be sent to an aerial platform into L data packet sub-streams and sends each of the L data packet sub-streams to one of the L cell site radio modules 200 which in turn transmits the data packet sub-stream on a beam using the antenna aperture connected to the transmit interface of the cell site radio module. In a variation of the embodiment, the available spectrum is divided into L frequency channels. In another variation of the embodiment, each data packet sub-stream is transmitted on a different frequency channel. In another variation of the embodiment, the L beams formed by the L antenna apertures point in the same direction toward the aerial platform.

In another embodiment, the number of radio modules and antenna apertures of the cell site communications equipment 403 (FIG. 2D), L, is an even number. The available spectrum is divided into L/2 frequency channels, each antenna aperture is assigned a frequency channel number and an antenna polarization where no two antenna apertures are assigned the same frequency channel and antenna polarization, the processor sub-system 198 receives data to be transmitted to N aerial platforms, splits each of the data packet streams into L sub-streams, sends N of data packet sub-streams, where each of the N sub-streams is destined to a different aerial platform, to one of the radio modules, and the radio module transmits the N data packet sub-streams on N different beams to different aerial platforms using the antenna aperture connected to the radio module and the frequency channel and the antenna polarization assigned to the antenna aperture.

In another embodiment, the processor 198 receives L different data packet streams, each stream destined to a different aerial platform, the processor sends each data packet stream to a different radio module, and each radio module transmits the received data packet stream on a beam using the antenna aperture connected to the radio module's transmitter.

In another embodiment, the cell site sector antenna points a beam toward each sub-sector, the aerial platform forms a beam toward the sub-sector beam, referred to as the current beam, with which it is communicating, and measures a signal quality metric on the current beam as well as the beams adjacent to the current beam, chooses the sub-sector beam with the highest received signal quality metric, and switches communications with the cell site to the chosen sub-sector beam.

The apparatus described in FIGS. 2A to 2D are exemplary illustrations of the systems and methods described in the embodiments. A person of ordinary skill in the art will readily recognize that other variations, combinations or additions of sub-systems may be used, without departing from the scope of the disclosure. As one example, the beamforming sub-system may be combined with the baseband modem sub-system. As another example, the transceiver sub-system may be combined with antenna elements.

55 Aerial Platform Apparatus

FIG. 3A illustrates an exemplary aerial platform communications module 401 comprising of two main sub-systems, an antenna sub-system 142, and a radio sub-system 150. The exemplary aerial platform antenna sub-system of FIG. 3A comprises of 3 antenna apertures 145-*k*, *k* an integer index identifying one of 3 different antenna apertures of the same type. Furthermore, the different antenna apertures may be tilted in different directions. In one embodiment of the antenna aperture 145, as illustrated in FIG. 3A, each antenna aperture further comprises of antenna elements 144-*j*, *j* identifying different antenna elements of the same type. Examples of antenna elements are dipole or patch elements.

The different antenna elements **144-j** of a given antenna aperture may be phased to form a beam in a given azimuthal and elevation direction. In one embodiment, the antenna elements **144-j** are phased to form a fixed beam that does not change with time. The advantage of a fixed beam is simplicity of the antenna. In another embodiment, the antenna element phases are changed with time in order to more accurately steer the beam toward the cell site as the aerial platform moves and changes its orientation toward the cell site with which it is communicating. In another embodiment, the antenna aperture **145** may be designed using a single element structure, such as a horn structure, to form one fixed beam. The antenna aperture that forms a single fixed beam using a single element structure has the advantage of being simpler and less expensive. A person of ordinary skill in the art will readily recognize that more than 3 antenna apertures may be used for the antenna sub-system of the aerial platform without departing from the scope of the disclosure.

When the antenna aperture **145** is capable of only forming a single fixed beam, there will be antenna gain loss due to so called scan loss in cases where the antenna aperture does not align with the cell site with which the aerial platform is communicating. Even when the antenna aperture is capable of dynamically steering its beam toward the cell site, there will be scan loss whose magnitude depends on the aerial platform's orientation with respect to the cell site location. The sub-system **148** of FIG. 3A, is a mechanical device that is capable of rotating the antenna sub-system **142** by a certain angle around its axis, in order to more accurately position the antenna beam toward a cell site. The mechanical device **148** may be a simple electromechanical switch which switches the antenna sub-system **142** to one of a few possible positions. This results in a simple and low weight mechanical switching device which is capable of turning the aerial platform antenna aperture beam toward the cell site with which it is communicating, thereby significantly reducing the scan loss. The aerial platform radio sub-system further comprises of an RF transceiver sub-system **152**, a beam former sub-system **154**, a baseband sub-system **156**, a processor sub-system **158**, and a GPS/gyroscope sub-system **159**. The GPS/gyroscope sub-system **159** estimates the aerial platform's position location coordinates, as well as the aerial platform antenna sub-system orientation relative to the cell sites. Sub-system **146** provides an RF interface between the antenna sub-system **142** and the radio sub-system **150**.

The aerial platform equipment **401** of FIG. 3A shows that each antenna aperture **145-k** is connected to a dedicated aerial platform radio sub-system **150-k**, k an integer index identifying different antenna apertures and radio sub-systems of the same type. The advantage of having a dedicated radio sub-system for each antenna aperture is to facilitate mesh network capability for the aerial platforms, where one aerial platform maintains multiple simultaneous communications links in different azimuthal directions. In the mesh network configuration, one aerial platform may be simultaneously communicating with multiple aerial platforms or cell sites. It is possible to have a number of radio sub-systems fewer than the number of antenna apertures, and switch the radio sub-systems to the antenna apertures that are being used for communications. FIG. 3B illustrates an exemplary aerial platform communications module **402** which comprises of only one radio sub-system **150**. In the system of FIG. 3B, the single radio sub-system **150** is switched to an antenna aperture **145-k** being used for communication, using the RF switching sub-system **149**. The RF switching sub-system **149** has connections to all 3 antennas, and to the radio sub-system **150** via RF interfaces **147-1**,

147-2, **147-3**, and **146**. In general, when there are fewer radio sub-systems than antenna apertures, the radio sub-systems may be shared by an antenna aperture using an RF switching sub-system such as in the exemplary diagram of FIG. 3B.

In the system of FIG. 3A, since there is a dedicated radio sub-system **150-k** for each antenna aperture **145-k**, one of the radio sub-systems **150-k** needs to be identified as the master which receives all signal quality measurements from other radio sub-systems of the same aerial platform, determines the aerial platform antenna aperture from which the strongest signal quality is received, and instructs the aerial platform radio sub-system of the corresponding antenna aperture to start communications with the cell site sector from which the strongest signal quality is received. In the system of FIG. 3B where there is only one radio sub-system **150**, the radio sub-system switches from one antenna aperture to the next, measures signal quality on reference signals received from cell sites on each antenna apertures, chooses the aerial platform antenna aperture on which it receives the highest signal quality, and establishes the communications link on the said antenna aperture and with the cell site from which the aerial platform antenna aperture receives the highest signal quality.

The aerial platform antenna sub-system described in conjunction with FIGS. 3A and 3B comprise of at least three antenna apertures to provide coverage in 360 degrees in azimuth using one of the antenna apertures. In another aerial platform antenna design for 360 degree coverage in azimuth, the antenna sub-system **142** comprises of only one antenna aperture and the mechanical steering mechanism **148** steers the antenna aperture in different azimuthal angles such as to point the antenna aperture beam toward a cell site with which the aerial platform radio sub-system is communicating, or to point the antenna aperture beam toward a cell site in order to measure the quality of the signal received from the said cell site. In order to minimize the size of the antenna fixture, the mechanical steering pivot from which the antenna is rotated in azimuth is placed in the center and under the single antenna aperture, and the antenna aperture is mechanically steered around the said pivot. In another aerial platform antenna sub-system embodiment, the antenna sub-system comprises of two antenna apertures. The two antenna apertures are placed back to back, each aperture covering an angular area of about 180 degrees, and the antenna apertures may be rotated in azimuth to point the peak of one of the apertures toward a cell site. The mechanical steering pivot is, as in the case of the single antenna aperture, placed in the center under the antenna apertures from which the antenna apertures may be rotated in azimuth. The angular mechanical steering range of the aforementioned two aperture antenna aperture sub-system is limited to 180 degrees which helps mitigate issues such as RF cable twisting.

The embodiments in this disclosure are described in conjunction with FIGS. 3A and 3B. However, a person of ordinary skill in the art will readily recognize that the embodiments described in this disclosure can be described in conjunction with the mechanically steerable single antenna aperture system without departing from the scope of the disclosure. As was mentioned previously, certain aerial platforms such as low attitude drones, e.g. the ones used for surveillance, may impose a weight and size limitation for the communications equipment on the drone. For these aerial platforms, the antenna sub-system may consist of one or more Omni-directional antennas. FIG. 3C illustrates an aerial platform communications equipment which comprises

of Omni antennas labeled by **142-j**, *j* an index identifying different instantiations of the Omni antennas of the same type. Depending on the size and weight requirements of the drone, the drone antenna sub-system may consist of as few as one Omni antenna. If the aerial platform antenna sub-system consists of multiple Omni antennas, then the multiple antennas may be combined on the receive side to increase the antenna gain toward the desired cell site with which the aerial platform is communicating. Similarly, the signal transmitted by the aerial platform radio sub-system may be sent on the multiple antennas by appropriately phasing the transmit signals to form a beam toward the desired cell site.

The baseband modem of sub-system **136** in FIGS. **2A** and **2B** of the cell site equipment, and baseband modem sub-system **156** in FIGS. **3A**, **3B** and **3C** of the aerial platform further comprise of a modulator and a demodulator sub-system. The modulator sub-system further comprises of at least the following sub-systems: an error correction encoder that encodes the information bits to be transmitted in a data packet into a set of coded symbols; the modulation symbol mapper/interleaver, which in some embodiments interleaves the coded symbols, maps the interleaved coded symbols into modulation symbols, and in some embodiments, interleaves the resulting modulation symbols. The demodulator sub-system further comprises of at least the following sub-systems: a deinterleaver/demapper, which in some embodiments deinterleaves the received modulations symbols, demaps the received modulation symbols into coded symbols, and in some embodiments deinterleaves the resulting coded symbols; and a decoder which decodes the coded symbols of a data packet to recover the original information.

FIG. **3D** illustrates an exemplary aerial platform communications equipment **403** comprised of two sub-systems **401a** and **401**, installed at different locations on the aerial platform. Communications module **401** is described in FIG. **3A**. Sub-system **401a**, referred to as the Remote Antenna Module (RAM), comprises of an antenna sub-system comprising multiple antenna apertures **145-k**, *k* an integer index identifying different sub-systems of the same type, and a radio transceiver sub-systems **152-k** interfaced to each antenna aperture. The RAM RF transceiver sub-system generates *M* digital IQ sample streams, one stream for the RF signal received from one antenna aperture element, and sends the *M* digital IQ sample streams to the beamformer **154-k** of sub-system **401** via an interface **410**. Interface **410** may be a USB or Ethernet interface or other types of interfaces supported over wire, fiber or other media. The beamformer combines the digital IQ samples received from the RF transceiver of RAM **401a** and from the RF transceiver of communications module **401** such as to maximize a certain received signal quality metric, and demodulates/decodes the combined digital IQ sample stream to recover the data packets transmitted to the aerial platform by the cell site transmitter on a given cell site beam and frequency channel and antenna polarization.

In one embodiment, the cell site communications equipment splits the data packet stream destined to an aerial platform into *L* data packet sub-streams and transmits each data packet stream on a different frequency channel or antenna polarization to the aerial platform, the RF transceivers of the RAM and **401** sub-systems generate digital IQ sample streams for each antenna element and each frequency channel or antenna polarization on which data is transmitted to the aerial platform, the beamformer sub-system of **401** generates a combined single digital IQ sample stream for each frequency channel and antenna polarization,

the baseband modem demodulates/decodes the combined digital IQ sample stream corresponding to each frequency channel and antenna polarization to recover the data packet sub-stream transmitted by the cell site on the corresponding frequency channel/antenna polarization, the aerial platform processor sub-system combines the decoded data packets from each frequency channel and antenna polarization into one data packet stream and sends the resulting data packet stream for presentation to the upper layer protocols.

In one embodiment, communications equipment **403** transmits data on multiple frequency channels and antenna polarizations wherein the processor of sub-system **401** splits the data received from upper layer protocols into multiple data packet sub-streams so that each sub-stream may be transmitted on a different frequency channel or antenna polarization, each data packet sub-stream is encoded and modulated by the baseband modem and the resulting data digital IQ samples for each data sub-stream is sent to the beamformer, the beamformer generates *M* beamforming digital IQ samples for each of the data digital IQ sample sub-streams received from the baseband sub-system and sends the resulting *M* beamforming digital IQ sample streams corresponding to the data stream for a unique frequency channel and antenna polarization pair to one of the transceiver sub-systems **401a** or **401**. Therefore, sub-systems **401** and **401a** transmit data packet sub-streams on either a different frequency channel or a different antenna polarization. The RF transceiver of **401** or **401a** upbands the *M* received digital IQ sample streams to generate *M* RF signals for the frequency channel corresponding to the beamforming IQ digital sample stream and sends the resulting *M* RF signals to the antenna elements of an antenna aperture. The cell site communications equipment recovers the data packets transmitted by the communications equipment **403** of an aerial platform on each frequency channel/antenna polarization, combines the received data streams from different frequency channel/antenna polarization pair into one data packet stream and presents the resulting data packet stream to the upper layer protocols.

The above embodiments described in conjunction with FIG. **3D** considered one communications module **401** and one RAM **401a**. However, a person of ordinary skill in the art will readily recognize that the same systems and methods described above in conjunction with FIG. **3D** also apply to a system comprising more than one communications module **401** or more than one RAM sub-system **401a**, without departing from the scope of this disclosure. The aerial platform communications equipment **403** of FIG. **3D** uses the aerial platform communications module **401** of FIG. **3A** as a sub-system. However, a person of ordinary skill in the art will readily recognize that the same systems and methods described above in conjunction with FIG. **3D** also apply to a system based on communications module **402** of FIG. **3B**, without departing from the scope of this disclosure.

Air Interface Protocol—Data Channels Types, Frame Formats and Timing

FIG. **4A** illustrates the frame structure on the forward link (cell site to aerial platform) and return link (aerial platform to cell site), the forward link and return link channel types, frame types, time slots, and frame and time slot timing for a TDD (Time Division Duplex) system. In a TDD system, the forward link and return link data are sent on the same frequency channel but during different time frames. The Forward Link Broadcast CHannel (FL-BCH) (FIG. **4A**) carries messages such as the system parameters, registration request response, and return link bandwidth assignment. The FL-BCH frame starts with a known preamble, which the

aerial platform radio sub-system searches to acquire the cell site signal and to decode the FL-BCH messages. Each sector and sub-sector of a cell site has its own unique preamble on the FL-BCH channel. FL-BCH system parameter message contains information on the forward link and return link frame structure, frames types, frame durations, and time slots. The FL-BCH channels are followed by a guard time greater than the largest Round Trip Propagation Delay (RTPD) from the cell site to the aerial platforms. The guard time is then followed by reception of the Return Link Random-Access Channel (RL-RACH) on which different aerial platforms send registration request messages, return link bandwidth request messages, and other system control messages. Note that the frame timeline in FIG. 4A is shown from perspective of the cell site radio sub-system. Each frame on the forward link or return link is further divided into time slots. The longer vertical lines in FIG. 4A delineate the different channel frame durations, and the smaller vertical lines delineate time slots within each frame. As can be seen in FIG. 4A, there are two types of forward link channels, the aforementioned FL-BCH, and the Forward Link Data Channel (FL-DCH) on which data is transmitted to the aerial platforms. Similarly, there are two return link channels, the aforementioned RL-RACH channel, and the Return Link Data Channel (RL-DCH) where aerial platforms transmit data to the cell sites during time slots previously assigned to each aerial platform. A super frame (FIG. 4A) starts with a FL-BCH, followed by the RL-RACH and then a number of pairs of FL-DCH and RL-DCH frames. Therefore, the aerial platforms that have not yet established a link to the network have the opportunity to associate with a cell site at the beginning of each super frame.

Following the end of reception of the last forward link data packet and prior to the beginning of the transmission on the return link during the aerial platform's assigned return link time slots, each aerial platform will delay its transmission by the difference between the largest Round Trip Propagation Delay (RTPD) between the cell site and the aerial platforms, and the RTPD of the said aerial platform. In one embodiment, an aerial platform uses knowledge of its own position location coordinates, as well as those of the cell site with which the aerial platform is communicating, to determine the required amount of delay prior to return link transmission to ensure that the RTPD from the cell site to the said aerial platform is equal to the largest RTPD. In another embodiment, the cell site radio sub-system estimates the time of arrival of the signal from each aerial platform, determines the amount of additional delay required prior to the return link transmission of each aerial platform to ensure all cell site to aerial platform links incur the same maximum RTPD, and sends the computed required delay to each aerial platform. The aerial platforms delay their return link transmissions according to the required values received from the cell site radio sub-system. Therefore, once the cell site stops transmitting on the forward link, there will be a gap (guard time) equal to the largest RTPD from cell site to the aerial platforms before the beginning of arrival of signal from an aerial platform at the cell site. During the guard time gaps, the cell site is neither transmitting nor receiving, and is therefore wasted bandwidth. The guard time synchronizes the forward and return link transmissions, which helps avoid interference from the transmitter into the receiver when cell site starts receiving data. In an FDD (Frequency Division Duplex) system, where the aerial platforms simultaneously transmit and receive on different frequency channels on the forward and return links, there is no need for a guard time.

In one embodiment, the data-link between a cell site and an aerial platform consists of a point to point link, whereby the cell site transmits data to the aerial platform on the FL-DCH frame, the aerial platform transmits data to the cell site during the following RL-DCH frame, and a given pair of consecutive FL-DCH and RL-DCH frames are dedicated to one aerial platform. If the boresights of the beams covering two aerial platforms are separated by less than a certain azimuthal angular value, then to reduce crossbeam interference between the said beams the two aerial platforms may send/receive data to/from the cell site in one of the following ways. In one embodiment, the beam covering the first aerial platform may also be used to communicate with the second aerial platform by sharing the FL-DCH and RL-DCH frame time slots between the two aerial platforms. In another embodiment, depending on the traffic requirements of the two aerial platforms, a certain fraction of the FL-DCH and RL-DCH frame pairs mentioned above are dedicated to each of the two aerial platforms; each aerial platform transmits and receives data during its dedicated FL-DCH and RL-DCH frame pairs. The aerial platforms are informed of their FL-DCH and RL-DCH frame pair allocations, and the position of the FL-DCH and RL-DCH frame pairs within the super frame using messages sent to the aerial platforms via the FL-BCH or FL-DCH channels. In another embodiment, the frequency channel is divided into two frequency channels, and each frequency channel is assigned to one of the two aerial platforms.

In one approach to the development of the aforementioned communications protocol, the 802.11 (also known as WiFi) standard is used as the air interface building block, and is modified to implement the air interface specification. The 802.11 standard uses CSMA (Carrier Sense Multiple Access) as the primary multiple access technique. In CSMA, each Access Point (AP) and Client Terminal (CT) prior to data transmission measures the total received power on a given frequency channel, and if the measured power is below a certain threshold, then the AP/CT determines that the frequency channel is idle and begins transmission on the said frequency channel only if the channel remains idle for a certain random back-off time. In the system of this disclosure, the aerial platform is the CT and the cell site equipment is the AP. The back-off time is used to avoid having two APs/CTs access the idle channel at the same time, which would result in a collision. For the CSMA scheme to work well, each AP/CT needs to be able to receive signals transmitted by any other AP/CT. In some embodiments, aerial platforms (equivalent of CTs) and cell sites (equivalent of APs) use narrow antenna beams, which implies a given aerial platform may not be able to detect signals transmitted by other aerial platforms. Therefore, if 802.11 protocol is used as the building block for implementing the aforementioned air interface for aerial platforms, the CSMA mechanism must be turned off and replaced by the FL-BCH, FL-DCH, RL-RACH, and RL-DCH channels, the frame structures, and signaling protocols described in previous embodiments. The aerial platforms, as described previously, detect the FL-BCH channel transmitted by a cell site, receive the system frame timing and RL-RACH channel timing from the FL-BCH messages, and send their association request message on the RL-RACH to the cell site, thereby avoiding the need for a CSMA mechanism. If there is a message collision on the RL-RACH, then the aerial platforms involved in the collision retransmit their messages during the next RL-RACH frame, but each aerial platform

backs off its retransmission by a random number of time slots (backoff time) in order to minimize probability of collision.

In the 802.11 protocol, each AP/CT after transmitting a number of data packets stops transmission, and waits for acknowledgement of the transmitted data packets from the other end of the link. In a TDD system, the sequence of transmit and receive frames will result in a guard time between the two frames. In a local area network where coverage radius is 100 meters or less, the guard time is at most a few micro-seconds. In the aerial platform communications system described in this disclosure, however, coverage radius of one cell site may be as much as 300 km resulting in a guard time requirement of 2 milli-seconds or more. Therefore, the transmit/receive phases between APs and CTs of a nominal 802.11 network will result in a large guard time overhead. In order to minimize the impact of the guard time overhead, the aforementioned communications protocol for aerial platforms divides the time into sequences of a FL-DCH followed by a RL-DCH frame, and the duration of the FL-DCH and RL-DCH frames may be chosen to be large enough to make the guard time overhead needed between the two frames relatively small.

Air Interface Protocol—Retransmission Protocols

The correct reception of each data packet must be acknowledged by the receiver in order to ensure error free data transmission. A retransmission mechanism, referred to as Retransmission Protocol (RP) in this disclosure, is required to retransmit the data packets that are not received correctly. In one embodiment, the acknowledgements for the data packets received from aerial platform/cell site in one RL-DCH/FL-DCH frame are sent to the cell aerial platform/cell site in one acknowledgement packet during the following FL-DCH/RL-DCH frame. In one embodiment, the acknowledgment packet contains the sequence number of data packets that were not received correctly in the previous frame, i.e. the sequence number of data packets that are missing in the receiver buffer. In a variation of this embodiment, the receiver maintains the received modulation symbols for all data packets in a buffer, and removes the modulation symbols corresponding to a data packet from the receiver buffer only after receiving an acknowledgement for the said data packet sequence number. In each data frame, the transmitter resends all data packets which have not been acknowledged by the receiver side. The receiver combines the modulation symbols corresponding to a retransmitted data packet with the corresponding modulation symbols of the same symbol position of the data packet with the same sequence number maintained in the receiver buffer from the previous transmission, and sends the combined modulations symbols to the decoder sub-system of the baseband modem to decode the corresponding data packet and recover the original transmitted information. Combining of the two modulation symbols corresponding to the same symbol position of two transmissions of the same data packet may be carried out using a number of signal processing techniques such as maximal ratio combining, or maximum likelihood combining to maximize the received signal strength or the received Signal to Interference plus Noise Ratio (SINR). The combined modulation symbols have more signal power than the same modulation symbols of each of the two individual transmissions of the same data packet, and the decoder will have a higher probability of correctly decoding the data packet using the combined modulation symbols.

In air interface protocol versions where the sequence number of data packets is part of the data packet and is

encoded with the data packet's information symbols, a mechanism is needed to determine the sequence number of the retransmitted data packets without having to decode the said data packets, so that the retransmitted data packet modulation symbols may be combined with the modulation symbols of the previously transmitted data packet with the same sequence number. In one embodiment, the data packet that is being retransmitted is sent in the same time slots of the data frame where the data packet with the same sequence number had been sent in the previous data frame as illustrated in FIG. 4B. FIG. 4B shows two consecutive FL-DCH frames. The sequence number of data packets range from 1 to L, where L is an integer indicating the largest sequence number, and is identified by $sn(1)$. Labels $D_{sn(1)}$ and $D_{sn(2)}$ in FIG. 4B refer to two data packets with increasing sequence numbers $sn(1)$ and $sn(2)$. Label t_n identifies the n-th time slot, where time slots in each frame begin with time slot number 1. Data packets $D_{sn(1)}$ and $D_{sn(2)}$ shown in FIG. 4B are of length m and q time slots respectively, are sent during time slots t_n to t_{n+m-1} and t_u to t_{u+q-1} in the first FL-DCH frame, and are assumed not to have been decoded correctly after the first transmission. These packets, as can be seen in FIG. 4B, are retransmitted in the second FL-DCH during the same time slots of the FL-DCH frame as the first transmission. Then, the receiver expects to receive the data packet corresponding to a missing sequence number in the same set of time slots of the frame where the said sequence number had been transmitted previously, and combines the modulation symbols of the data packet in the buffer with the newly received modulation symbols of the data packet with the same sequence number.

In another embodiment, the retransmitted data packets are placed at the beginning of the FL-DCH frame according to an increasing or decreasing sequence number convention. In FIG. 4C, it is assumed the data packets are retransmitted according to an increasing sequence number order. As illustrated by FIG. 4C, data packets $D_{sn(1)}$ and $D_{sn(2)}$ whose sequence numbers $sn(1)$ and $sn(2)$ are assumed to be in increasing order are retransmitted at the beginning of the second FL-DCH frame in the same order, and occupy the same number of time slots m and q, but this time they occupy time slots t_1 to t_m , and t_{m+1} to t_{m+q} . Then, the receiver lists the sequence numbers of the missing data packets according to the same increasing or decreasing sequence number convention, and demodulates the retransmitted data packets of each missing sequence number in the time slots of the data frame according to the said list, and combines their modulation symbols with those of the previously transmitted data packet with the same sequence number that is in the receiver buffer memory. The RPs in the above embodiments were described using the example of FIGS. 4B and 4C where one retransmitted data packet is combined with the original unacknowledged data packet. A person of ordinary skill in the art will readily recognize that the same systems and methods for retransmission of data packets also apply to the case of more than one retransmission of the same data packet, without departing from the scope of this disclosure.

In another RP embodiment, the data packet with sequence number $sn(1)$ is encoded using an error correction code, and the encoded data packet is divided into C, an integer number, components labeled by $D_{sn(1)}^c$, $1 \leq c \leq C$. The data packet components are transmitted sequentially in increasing index c in consecutive FL-DCH frames, one component per frame. After reception of each component of the data packet, the receiver attempts to decode the data packet using all received components of the same data packet, and sends an

acknowledgment to the transmitter once the data packet is correctly decoded. Once an acknowledgement is received for a data packet sequence number, transmission of remaining components of the acknowledged data packet is aborted. The RP scheme just described is referred to an Incremental Redundancy RP (IR-RP) because the transmitter sends incremental amounts of redundancy until the receiver successfully decodes the data packets using all received redundancy information. Note that different components of a data packet need not be of the same size. In one embodiment, the data packet is encoded using an error correction code, the first component is the largest and includes the original data information plus a certain number of redundancy symbols, and the following components carry incremental amounts of the remaining redundancy symbols from the encoded symbols. The receiver maintains all components of each data packet in the receiver buffer until the data packet is correctly decoded, at which time the components of the correctly decoded data packet are removed from the buffer. FIG. 4D illustrates transmission of two components of two data packets with sequence numbers sn(1) and sn(2). As can be seen, the first components are of length m and q time slots, and the second components are of length m' < m and q' < q.

In a variation of the above RP embodiments, the sequence number of each packet is placed outside the information portion of the data packet so that the sequence number of the data packet may be determined prior to decoding of the data packet. In one embodiment, each data packet is preceded by a preamble which contains the sequence number of each data packet. The preamble is detected and decoded first, and the sequence number of the data packet following the preamble is determined. Once sequence number of each received data packet is determined, the multiple data packets corresponding to the same sequence number are sent to the decoder to recover the information data. In another embodiment, a control packet which contains the sequence number and the time slots that each data packet occupies in the corresponding frame is placed at the beginning of each FL-DCH or RL-DCH frame. The receiver decodes the control packet first, and retrieves the sequence number and location of each data packet in the frame; then, multiple data packets corresponding to the same sequence number are sent to the decoder to recover the information data as described in previous embodiments. The above retransmission mechanism embodiments were described in conjunctions with FIGS. 4B, 4C, and 4D, for forward link data packet transmission where the aerial platform is the receiver and the cell site is the transmitter. A person of ordinary skill in the art will readily recognize that the same systems and methods for retransmission of data packets also apply to the return link, where the aerial platform is the transmitter and the cell site is the receiver, without departing from the scope of the disclosure.

Air Interface Protocol—Modulation Constellation and Code Rate (MCCR) Determination

The aerial platform and the cell site radio sub-systems may choose from a set of Modulation Constellations and error correction Code Rates (MCCRs) with which to encode and modulate the information to generate a coded data packet to transmit. In addition to the MCCR, the transmitter also chooses an RP (Retransmission Protocol), such as the ones described in previous embodiments. The higher the modulation constellation and the higher the error correction code rate, the higher the data rate. However, higher modulation constellation and higher code rates also require higher received Signal to Interference plus Noise Ratio (SINR) to reliably decode the data packets. Packet Error rate (PER) is

a function of the MCCR and the received SINR. The MCCR and an accompanying RP must be chosen so that the PER after all retransmissions be below an a-priori PER threshold, T_{PER} , at a given SINR. Some upper layer network protocols, such as TCP, use window-based flow control mechanisms where a maximum number of unacknowledged data packets equal to the window size are allowed at a given time. When the window becomes full, some protocols adaptively reduce the window size to reduce congestion in the network, which results in the reduction of data rate at the source. In order to minimize the probability of window size reduction, in some systems T_{PER} of as low as 10^{-4} is chosen. In other words, upper layer network protocols are usually designed for wireline communications systems where data packet loss is very low. In one wireless communications link management methodology, the MCCR and the RP are chosen such that the PER seen by the upper layer network protocol is as low as the data packet loss in wireline networks.

Let $MCCR_i$ denote the i-th MCCR in the list of available MCCRs, and DR_i be the data rate corresponding to the $MCCR_i$. In one embodiment for MCCR determination, the RP retransmits the whole data packet as described above in conjunction with FIGS. 4B and 4C and the receiver combines modulation symbols of the multiple copies of the same data packet. The MCCR whose index i maximizes the average data rate subject to

$$PER(MCCR_i, SINR+3 \text{ dB}) < T_{PER}, \quad (2)$$

is used at the given SINR, where $PER(MCCR_i, SINR)$ is the PER of MCCR at the given SINR in dB scale. The average data rate is approximately given by

$$DR_i \times (1 - PER(MCCR_i, SINR)) + 0.5 DR_i \times PER(MCCR_i, SINR) \times (1 - PER(MCCR_i, SINR+3 \text{ dB})) \approx DR_i \times (1 - 0.5 \times PER(MCCR_i, SINR)). \quad (3)$$

In one embodiment, the MCCR whose index i maximizes the right-hand side of (3) subject to condition (2) is used by the transmitter to encode the data packets prior to transmission. This optimization criterion chooses an MCCR so that after one retransmission of the data packet PER be $< T_{PER}$. Note that in an AWGN communications channel, after one retransmission the receiver measures SINR+3 dB because per the retransmission mechanism the receiver combines the modulation symbols of the same symbol position of the two transmissions, thereby increasing the SINR by 3 dB.

The RP and MCCR determination embodiments described above in conjunction with FIGS. 4B and 4C considered the case of one retransmission of the data packet. A person of ordinary skill in the art will readily recognize that the same systems and methods for retransmission of data packets and for MCCR determination also apply in conjunction with more than one retransmission of the same data packet, without departing from the scope of the disclosure.

For an IR-RP mechanism described above in conjunction with FIG. 4D and with C=3 data packet components, the initial MCCR index i is chosen such that the PER after the second retransmission is below T_{PER} . Note that in the IR-RP of FIG. 4D, the effective MCCR of the combined transmissions changes after retransmission of each component because after each retransmission the effective error correction code rate of the combined transmissions is reduced. Therefore, the 3 MCCRs are denoted by $MCCR_i$, $MCCR_{i'}$, and $MCCR_{i''}$, corresponding to the MCCR of the first component transmission, MCCR of the first and second

component transmissions combined, and that of the combined three components. Then, average data rate is maximized over all MCCR indices i subject to

$$\text{PER}(\text{MCCR}_{i^n}, \text{SINR}) < T_{\text{PER}} \quad (4)$$

The average data rate in the IR-RP with 3 retransmissions ($C=3$) is approximately given by

$$\begin{aligned} & \text{DR}_i \times (1 - \text{PER}(\text{MCCR}_i, \text{SINR})) + \text{DR}_{i'} \times \text{PER}(\text{MCCR}_i, \\ & \text{SINR}) \times (1 - \text{PER}(\text{MCCR}_{i'}, \text{SINR})) + \text{DR}_{i''} \times \text{PER} \\ & (\text{MCCR}_{i'}, \text{SINR}) \times \text{PER}(\text{MCCR}_{i''}, \text{SINR}) \times (1 - \text{PER} \\ & (\text{MCCR}_{i''}, \text{SINR})), \end{aligned} \quad (5)$$

where DR_i , $\text{DR}_{i'}$, and $\text{DR}_{i''}$ are data rates corresponding to MCCR_i , $\text{MCCR}_{i'}$, and $\text{MCCR}_{i''}$. In one MCCR determination embodiment corresponding to IR-RP with $C=3$, the MCCR index i that maximizes (5) subject to (4) is used at the given SINR. For $C=2$, the average data rate is approximated by

$$\begin{aligned} & \text{DR}_i \times (1 - \text{PER}(\text{MCCR}_i, \text{SINR})) + \text{DR}_{i'} \times \text{PER}(\text{MCCR}_i, \\ & \text{SINR}) \times (1 - \text{PER}(\text{MCCR}_{i'}, \text{SINR})). \end{aligned} \quad (6)$$

In one MCCR determination embodiment corresponding to IR-RP with $C=2$, the MCCR index i that maximizes (6) subject to $\text{PER}(\text{MCCR}_i, \text{SINR}) < T_{\text{PER}}$ is used at the given SINR. The systems and methods for MCCR determination corresponding to IR-RP were described for $C=2$ and $C=3$. A person of ordinary skill in the art will readily recognize that the same systems and methods also apply to the case of $C > 3$, without departing from the scope of the disclosure.

In one embodiment, in order to increase the probability of correct reception of missing data packets in the receiver buffer, the transmitter allocates more power to the beams during retransmission of data packets. In certain frequency bands, such as the U-NII-3 and U-NII-1 bands in the 5 GHz ISM band, there is a limit on the total conducted power into the antenna fixture which is shared by multiple beams formed by the antenna fixture. In one embodiment, the available power is equally allocated to the N different beams formed by one antenna fixture, referred to as the nominal beam power. In another embodiment, more than the nominal power is allocated to one beam during the time slots corresponding to retransmission of a packet. Then, in order to maintain the total conducted power into all N beams generated by an antenna fixture at the allowed limit, the total power allocated to the other beams must be reduced by the same amount. In another embodiment, the power allocated to the different beams is determined based on the received SINR on each beam. More power is allocated to the beams with smaller received SINR, and less power is allocated to the beams with larger received SINR. However, the total power allocated to all beams must be maintained below the specified limit. In other words, more power is allocated to the cell site beams corresponding to the aerial platforms that receive more interference.

Network Acquisition and Beam Tracking

There are two main phases during the communications between an aerial platform and the network of cell sites, initial network acquisition and subsequent aerial platform tracking. During the initial acquisition phase, the aerial platforms and the network of cell sites establish the initial communications links, and the aerial platforms register with the network. In one embodiment, the cell sites transmit a FL-BCH channel which begins with a known preamble. The aerial platforms search for the broadcast channel preamble signals from the cell sites, decode the FL-BCH messages, and read network information and configuration messages. In one variation of the embodiment, the aerial platform sequentially points, using mechanical or electronic beam steering, the boresight of its antenna beam toward different

angular positions in 360° in azimuth, searches for the preamble of the FL-BCH messages transmitted by the cell sites, measures the signal quality of the detected FL-BCH messages from the cell sites, ranks the measured signal qualities at different aerial platform beam angular positions, and establishes a link between the cell site and aerial platform angular beam position from which it receives the strongest signal quality. Note that in the aforementioned acquisition embodiment, the aerial platform radio sub-system does not use any information regarding the position coordinates of the cell sites or those of the aerial platform in searching for FL-BCH frames. In another variation of the embodiment, the aerial platform radio sub-system uses a priori knowledge of the position coordinates of the cell site and those of the aerial platforms obtained from GPS/gyroscope sub-system **159** of the aerial platform radio sub-system (FIGS. **3A**, **3B** and **3C**), to point the aerial platform's beam toward the position of the cell sites and searches for the FL-BCH messages sent by the cell sites. The configuration messages sent by the cell sites on the FL-BCH contains information on the RL-RACH on which the aerial platform may sent messages such as the registration and bandwidth request to the network.

In one embodiment, sector coverage area of a cell site is further divided into a number of fixed sub-sectors and each sub-sector is covered by one cell site beam during the FL-BCH transmission, the beam covering the sub-sector referred to as the sub-sector-beam. In one exemplary cell site design shown in FIG. **5A**, the cell site is divided into 3 sectors, and each sector is further divided into 8 sub-sectors. The three sectors in FIG. **5A** are delineated by the dashed lines and are labeled by letters α , β and γ . Each of the 8 sub-sectors is covered by a beam labeled by **112-j**, j an integer index identifying different instances of the same beam type. In FIG. **5A**, only the sub-sector-beams of sector β are shown. The sub-sector-beams of sectors α and γ are similar to those of sector β . In this example, each sub-sector covers an azimuthal angular area of 15° because 8 sub-sectors cover one of each 3 sectors ($360^\circ/3/8=15^\circ$). Therefore, in this example the sub-sector-beam covering each sub-sector during FL-BCH transmission has beamwidth of 15° . In one embodiment, the sub-sector-beams **112-j** are fixed and have some overlap to ensure coverage is provided in all directions. In one embodiment, in order to reduce interference between adjacent sub-sector-beams, the available frequency channels are divided into two sets **F1** and **F2**, a different set of frequency channels, **F1** or **F2** are assigned to adjacent sub-sectors for transmission of the FL-BCH and RL-RACH frames, referred to as frequency reuse of order **2**. In frequency reuse of order **2**, no two adjacent sub-sectors use the same frequency channel. In another embodiment, the sub-sectors are divided into two subsets, each subset comprising of non-adjacent sub-sectors, all frequency channels are used in all sub-sectors, two FL-BCH frames are provisioned in each super frame, during the first FL-BCH frame only the first subset of sub-sectors transmit and during the second FL-BCH only the second subset of sub-sectors transmit, thereby reducing interference in adjacent sub-sectors during transmission of FL-BCH frames. In one embodiment, in order to provide higher gain during the data transmission frames, the beam that is used to send data on the FL-DCH to the aerial platform or to receive data from the aerial platform on the RL-DCH have a narrower beamwidth than that of the sub-sector-beam used during the FL-BCH and RL-RACH transmissions. For instance, FIG. **5B** shows two beams **113-1** and **113-2** that are narrower than

the sub-sector-beams **112-j**, and are used during the FL-DCH and RL-DCH frame transmissions.

If the forward link and return link frames of different sub-sectors of the same sector are not synchronized, then at a given time some sub-sectors will be transmitting while others are receiving, which in a TDD system will result in interference into the receivers. In one embodiment, in order to minimize interference between adjacent sub-sectors, the forward link and return link frames of adjacent sub-sectors are synchronized, and the cell site radio sub-system sends the FL-BCH frame simultaneously on all or a subset of the sub-sector-beams of the same sector. The FL-BCH of each sub-sector has a sub-sector specific preamble, and contains messages that have sector and sub-sector related information. The aerial platform sends its registration message on the RL-RACH channels corresponding to the same sub-sector on which it detects the FL-BCH messages. In one embodiment, the cell site uses the same sub-sector-beam to receive the RL-RACH frame as used during the FL-BCH frame. Then, the cell site radio sub-system detects the registration message sent by an aerial platform on the same sub-sector-beam that the corresponding FL-BCH is sent. The example of cell sites comprising of 3 sectors, each sector comprising of 8 sub-sectors, and each sub-sector beam having beamwidth of 15° is used only for illustration purposes. A person of ordinary skill in the art will readily recognize that a number of sectors other than 3, a number of sub-sectors other than 8, and sub-sector-beams with beamwidth other than 15° may be used without departing from the scope of the disclosure.

In another embodiment for detecting the aerial platform's registration message, the cell site antenna sub-system forms narrow beams within the sector coverage area, and searches for signals sent by aerial platforms within each narrow return link beam. The cell site radio sub-system ranks the quality of the signals received from aerial platforms on the different narrow return link beams, and for each aerial platform chooses the narrow return link beam with strongest signal quality on which to demodulate and decode the messages received from the said aerial platform. The beam chosen during the acquisition phase is referred to as the current beam, and will be used for communications with the aerial platform during the aerial platform tracking phase which will be described later.

In another embodiment of the acquisition phase, the aerial platform points its antenna beam toward the cell sites, but instead of searching for the FL-BCH sent by the cell sites directly sends its registration message on the RL-RACH to the cell site to which it is pointing its beam; in this embodiment, the aerial platform radio sub-system needs a priori information regarding the RL-RACH parameters such as the frequency channel, time slot or the code that the different cell sites and their sub-sectors use to detect the RL-RACH messages. In one embodiment, a dedicated frequency channel is used by the cell sites on which to receive the RL-RACH. In one embodiment, the dedicated RL-RACH frequency channel may be divided into time slots and the aerial platforms send RL-RACH channel messages, such as the registration or bandwidth request messages, on the said RL-RACH frequency channel using Aloha protocol. In another embodiment, the dedicated RL-RACH frequency channel is shared by the aerial platforms in a spread spectrum multiple access fashion using predefined spreading codes. Each aerial platform uses a predefined code to encode its messages prior to transmitting the messages on the RL-RACH frequency channel. In another embodiment, instead of allocating a dedicated frequency channel or time

slots to the RL-RACH channel, the aerial platforms transmit their random-access messages on a spread spectrum channel as an underlay to the data channels on the return link; in this embodiment, the aerial platforms encode their random-access messages using predefined spread spectrum codes, and transmit the resulting waveform on one of a number of frequency channels that are used for data transmission. The underlay spread spectrum random access channel may be sent at low data rate so that the RL-RACH messages create negligible interference to the dedicated data channel being sent on the same frequency channel.

Once the cell site radio sub-system receives a registration message on the RL-RACH from an aerial platform, it sends a registration acknowledgement message to the said aerial platform on the FL-BCH or the FL-DCH completing the registration process, and establishes a data-link between the cell site and an aerial platform. Then, the aerial platform is said to be associated with the cell site sub-sector on which the registration process is completed, and the corresponding sub-sector is referred to as the current active sub-sector for the aerial platform. The aerial platform continues monitoring the FL-BCH of the current sub-sector until the aerial platform moves into the coverage area of an adjacent sub-sector and is handed off to the adjacent sub-sector. During data transmission between an aerial platform and a cell site, the aerial platform is said to be in active mode.

If an aerial platform does not have data to transmit and the cell site also does not have data to send to the said aerial platform, then the aerial platform will enter idle mode. In the idle mode, the aerial platform points its beam toward the current sub-sector with which it is associated, and decodes the FL-BCH messages sent by the corresponding cell site sector. If cell site has data to send to an aerial platform in idle mode, the cell site will inform the aerial platform by sending a paging message to the aerial platform on the FL-BCH channel of the sub-sector with which the aerial platform is associated, and the aerial platform enters active mode following the reception of the paging message. Similarly, when an aerial platform in idle mode and has data to send to the cell site, the aerial platform sends a bandwidth request message on the RL-RACH of the current sub-sector with which the aerial platform is associated, the cell site sends a bandwidth grant message to the said aerial platform on the FL-BCH or FL-DCH channels, and the aerial platform enters active mode following reception of bandwidth grant messages from the cell site. In the idle mode, the aerial platform radio sub-system monitors the FL-BCH channel signal strength of the sub-sector adjacent to the current sub-sector, and if the signal strength of one of the adjacent sub-sectors is higher than that of the current sub-sector by a certain threshold, the aerial platform sends a handoff request message to the cell site on the current sub-sector requesting to be associated with the candidate handoff sub-sector with higher signal strength, the cell site sends a handoff grant message to the aerial platform on the current sub-sector, and upon reception of the handoff grant message the candidate handoff sub-sector will become the aerial platform's new current sub-sector.

Cell Site Beam Steering

The cell site beam that points toward the aerial platform during active data transmission mode is referred to as the data-beam. In order to provide higher gain toward the aerial platform, in some embodiments the beamwidth of the data-beam is chosen to be narrower than that of the sub-sector beam. For instance, FIG. 5B illustrates two data-beams **113-1** and **113-2** that are narrower than sub-sector-beams **112-j**. In one embodiment for cell site data-beam design, the

data-beam boresight can take one of a number fixed angular positions within a sub-sector, and the data-beam fixed angular beam position that provides the highest signal quality to the aerial platform receiver is chosen as the beam position at which the cell site points its beam toward the aerial platform, and is referred to as the current data-beam. In one embodiment for tracking the current data-beam to accurately point toward the aerial platforms, the cell site radio sub-system searches the return link of the aerial platform on the current data-beam as well as the two data-beam angular positions adjacent to the current data-beam angular position. If the signal quality on one of the adjacent data-beam angular positions is larger than that of the current data-beam, then the cell site radio sub-system designates the said adjacent data-beam angular position as the new current data-beam. In another embodiment, the cell site radio sub-system dithers the current data-beam in the predefined fixed angular values around the current data-beam angular position, measures the signal quality received on the dithered angular data-beam position, and chooses the angular position among the current data-beam position and the dithered data-beam position with the strongest signal quality as the new current data-beam angular position at which to point the cell site beam toward the aerial platform. In another embodiment of cell site beam tracking toward the aerial platform, the aerial platforms periodically transmit their position coordinates to the cell sites, and the cell sites point the boresight of their data-beams toward the latest position coordinates of the aerial platform.

In another cell site beam forming embodiment during the tracking phase, a cell site sector antenna sub-system continuously steers a data-beam toward each aerial platform within the coverage area of a given sector, referred to as continuous beam steering scheme, the beam angular position taking on any real value. In other words, within the coverage area of a sector antenna, the cell site sector antenna maintains a continuously steered data-beam toward each aerial platform and only hands off the aerial platform to another cell site sector when the said aerial platform moves outside the coverage area of the current sector with which it is communicating. The cell site sector antenna sub-system steers its data-beam toward an aerial platform such as to maintain the peak of the cell site data-beam toward the said aerial platform. FIG. 6A shows two data-beams (113-1 and 113-2) pointing toward two different aerial platforms. The angular beam spacing, φ , between two cell site beams, as shown in FIG. 6A, is the angle between the dotted lines from the cell site to the peaks of the two data-beams. The cell site radio sub-system assigns different frequency channels or antenna polarizations to cell sites data-beams whose angular spacing, φ , is less than a predefined threshold φ_r , and assigns all available frequency channels to data-beams whose angular spacing from all other data-beams is larger than the said threshold φ_r . In one embodiment, the threshold φ_r is chosen such that for any data-beams spaced by larger than φ_r , the crossbeam interference between the two data-beams is smaller than a threshold resulting in a data rate above a threshold. When the two data-beams covering two aerial platforms are separated by more than φ_r , then the two data-beams may use all available spectrum, frequency channel sets F1 and F2 as marked inside each data-beam in FIGS. 6A and 6D.

As two aerial platforms move in opposite directions, the angular spacing between the data-beams covering the two aerial platforms becomes less than φ_r , which causes excessive crossbeam interference for the co-frequency channels, at which time each aerial platform is assigned a different set

of frequency channels in order to avoid crossbeam interference at the receivers of the two aerial platforms, as shown in FIGS. 6B and 6C where data-beams 113-1 and 113-2 are assigned separate frequency channel sets F1 and F2. In FIGS. 6A to 6D, it is assumed that the aerial platform of data-beam 113-1 is moving in a clockwise direction relative to the cell site, and the aerial platform being covered by data-beam 113-2 is moving in a counter-clockwise direction. Then, as shown in FIG. 6C, at some point data-beams 113-2 and 113-1 move past each other, and each data-beam is served by a different frequency channel set, or a different set of time slots on the same frequency channel, until the angular spacing of the two data-beams becomes larger than the threshold φ_r , as shown in FIG. 6D where both data-beams may use all available frequency channel sets and all time slots while maintaining the crossbeam interference on the co-frequency channels below a predefined value. In FIGS. 6B and 6C, the two beams 113-1 and 113-2 that use different sets of frequency channels are shown by solid and dotted triangular shapes to emphasize the use of different sets of frequency channels by the two data-beams. In FIGS. 6A and 6D, the two beams 113-1 and 113-2 that use the same sets of frequency channels are both shown by solid triangular shapes. When assessing the angular spacing of data-beams adjacent to a data-beam in determining the frequency channel, time slots, and antenna polarization assignment for each data-beam, beams in adjacent sectors need also be considered to ensure that no two data-beams of the cell site whose angular spacing is less than the φ_r would be assigned the same frequency channel, time slot, and antenna polarization.

The cell site radio sub-system may speed up the beam tracking process by using the aerial platform heading information provided by the aerial platform, or by predicting the aerial platform heading by applying predictive filtering to the recent cell site beam adjustments. Knowledge of the aerial platform heading will allow search of the candidate beam positions only in the angular direction of movement of the aerial platform, thereby reducing the search time. When the aerial platform antenna beam is steered toward the cell site using mechanical steering mechanism, steering errors may accumulate due to the imperfections and artifacts of the mechanical parts such as the motor backlash. These errors may be mitigated by also using forward link signal quality measurements at the aerial platform. The aerial platform radio and antenna sub-systems dither the aerial platform antenna beam in at least one candidate beam position around the current aerial platform beam position, measure the received signal quality at the current beam position as well as at the dithered candidate beam positions, and choose the beam position with highest signal quality for the new aerial platform current beam position.

Cell Site to Aerial Platform Assignment

In the forthcoming discussion, systems and methods are described for assigning aerial platforms to cell sites, and specifying an accompanying frequency reuse pattern, such as to optimize certain network performance metrics. The following terminology is defined to facilitate the discussion.

Definitions:

- a. N_c —number of cell sites in the network;
- b. N_b —number of beams in a cell site;
- c. N_a —number of aerial platforms in active mode in the network;
- d. different cell sites, aerial platforms, and cell site beams are, respectively, identified by integer indices i, j and k , where $1 \leq i \leq N_c$, $1 \leq j \leq N_a$, and $1 \leq k \leq N_b$;
- e. AS—set of aerial platforms in active mode;

- f. FRP(q)—the q-th network Frequency Reuse Pattern (FRP) that specifies the frequency channels assigned to each aerial platform to cell site link in the network, where q is an integer index identifying different frequency reuse patterns;
- g. APCS($\{(i, j)\}$, FRP(q))—is an Aerial Platform to Cell Site beam assignment set where each of the N_a aerial platforms are associated with a pair (i,j), one for each aerial platform, the pair (i,j) indicates aerial platform j is assigned to cell site i, and FRP(q) is the frequency reuse pattern with index q associated with the set $\{(i,j)\}$ that specifies the frequency channels assigned to each link (i,j) in the set $\{(i,j)\}$;
- h. P_{ijk} —transmit power from the k-th beam at the i-th cell site to the j-th aerial platform;
- i. P_{aj} —transmit power of the j-th aerial platform;
- j. W_{ijk} —thermal noise power in the frequency channel between aerial platform j and cell site i, where W_{ij} is the corresponding frequency channel bandwidth and N_o is thermal noise power spectral density;
- k. $SINR_{FRP(q)}^j$ —SINR received at aerial platform j for frequency reuse pattern FRP(q);
- l. L_{ij} —propagation path loss from cell site i to aerial platform j;
- m. $B_{ijk,j'}$ —antenna gain of the k-th beam of i-th cell site toward aerial platform j', when cell site i is pointing its k-th beam toward, and is communicating with, aerial platform j;
- n. $A_{j,i}$ —antenna gain of the j-th aerial platform toward cell site when aerial platform j is pointing the boresight of its beam toward, and is communicating with, cell site i;
- o. (FCH((i,j), FRP(q))=FCH((i_o, j_o), FRP(q))) means the aerial platform j to cell site i link is also assigned the Frequency CHannels (FCH) that are assigned to the aerial platform j_o to cell site i_o link, corresponding to frequency reuse pattern FRP(q);
- p. CS(j)—set of cell sites from which the j-th aerial platform receives adequate signal power to establish a communications link with a specified minimum data rate;
- q. $I_{ij,Ext}$ —external interference, from exogenous users other than the cell sites under consideration, received on a given frequency channel at the receiver of aerial platform j that is pointing its beam toward cell site i;
- r. $I_{ik,Ext}$ —external interference, from exogenous users of the frequency band other than the aerial platforms under consideration, received on a given frequency channel at the receiver of k-th beam of cell site i.

In one embodiment, an aerial platform j may estimate $I_{ij,Ext}$ by decoding the preamble sent by cell site i on the FL-BCH frame of the sub-sector-beam with which the aerial platform is associated, estimating the total received power and the received preamble signal power, and subtracting the preamble signal power and the ambient noise floor power from the total received power. The estimated external interference power is filtered over a number of measurement samples and then sent to the network control entity, along with the position location coordinates and orientation of the aerial platform antenna beam, to be stored for later SINR calculations. The external interference may similarly be estimated from the FL-DCH channel. If the external interference is excessively high, then the aerial platform receiver may not be able to decode the preamble on FL-BCH, in which case in one embodiment the $I_{ij,Ext}$ is estimated by measuring the total received power on the frequency channel. In one embodiment, cell site i may estimate $I_{ik,Ext}$ by

decoding the preamble sent by an aerial platform on the RL-RACH frame of the sub-sector-beam with which the aerial platform is associated, estimating the total received power and the received preamble signal power, and subtracting the preamble signal power and the ambient noise floor power from the total received power. The estimated external interference power is filtered over a number of measurement samples and sent to the network control entity, along with the direction of cell beam over which the exogenous interference is estimated, to be stored for later SINR calculations. The external interference may similarly be estimated from the RL-DCH channel. If the external interference is excessively high, then the cell site receiver may not be able to decode the signal on RL-RACH or RL-DCH, in which case in one embodiment the $I_{ik,Ext}$ is estimated by measuring the total received power on the frequency channel.

In another embodiment for exogenous interference measurement, cell sites do not transmit during certain time slots allocated for measuring exogenous interference, referred to as interference measurement time slots. Aerial platforms point their antenna beams in different directions, estimate total received power in each direction during the interference measurement time slots, and subtract the thermal noise power from the total received power to estimate the exogenous interference power. Aerial platforms send the estimated exogenous interference power along with the aerial platform position coordinates and the aerial platform antenna beam orientation to the network control entity. Certain time slots are similarly allocated on the reverse link for measuring reverse link exogenous interference power during which no aerial platform transmits. Cell sites measure reverse link exogenous interference power during the reverse link interference measurement time slots, and send the measured interference powers, along with the cell site beam orientation, to the network control entity.

Herein, the word assignment is used as a short form for the aerial platform to cell site beam assignment and its associated frequency reuse pattern, APCS($\{(i, j)\}$, FRP(q)), defined previously. In one assignment embodiment, frequency reuse order of 1 is assumed and aerial platform j is assigned to the cell site i from which it receives the strongest signal strength. This cell site beam assignment method may result in assigning a large number of aerial platforms to one cell site when there are a large number of aerial platforms in proximity of a given cell site. Assigning a large number of aerial platforms to one cell site will result in low data rates to aerial platforms and low usage of the network resources. For instance, commercial and general aviation aircraft tend to travel in certain corridors. In other words, the air traffic density for aircraft may not be uniformly distributed in 360 degrees in a given cell site. Then, a beam assignment whereby each aircraft is assigned to the cell site to which it is closest, or from which it receives the highest signal power, may result in assigning many aircraft to the same cell site sector and to cell site beams that would overlap significantly. The overlapped cell site beams create crossbeam interference. The crossbeam interference increases interference to the receiver of each aerial platform thereby reducing the SINR that each aerial platform receives, resulting in inefficient use of the spectrum and low data rates to the aircraft communicating using the overlapped beams. FIG. 7A, illustrates a scenario where four aerial platforms **140-1**, **140-2**, **140-3** and **140-4** are inside a cell site coverage area **110**, and communicate with cell site equipment **160** using the four cell site beams **113-1**, **113-2**, **113-3** and **113-4**, respectively. In the example of FIG. 7A, each aerial platform communi-

cates with the cell site that is closest to the aerial platform. As can be seen, the four beams in FIG. 7A overlap significantly which will result in large crossbeam interference, thereby reducing the received SINR, and reducing the corresponding data rate at each aerial platform receiver subsystem. FIG. 7B illustrates a cell site assignment assuming frequency reuse order of 1 where the four aerial platforms are assigned to cell sites such as to minimize crossbeam interference between the beams from aerial platforms to their assigned cell sites. As can be seen in FIG. 7B, under the crossbeam minimization criterion three of the aerial platforms are assigned to other farther cell sites. Network performance metrics and systems and methods are needed for assignment of aerial platforms to cell sites and devising a frequency reuse pattern for the assignment, such as to optimize the specified network performance metrics. u

The NC (Network Controller 180 in FIGS. 2A and 2B) generates a set AS of all aerial platforms that are in active mode, or are transitioning into active mode, and must be assigned to a cell site. For each aerial platform j in the set AS, NC determines the set of cell sites, defined above as $CS(j)$, from which the aerial platform will receive adequate signal strength, or adequate SNR (received Signal power to Noise power Ratio), to achieve a certain minimum data rate in absence of any interference from other beams. In other words, the set $CS(j)$ contains indices of all cell sites which are potential candidates to be assigned to the j -th aerial platform. As will be described in the forthcoming embodiments, $APCS(\{(i, j)\}, FRP(q))$ is generated in such a way as to optimize a certain performance criterion. For each aerial platform j and cell site i pair in the set $APCS(\{(i, j)\}, FRP(q))$, the NC estimates received $SINR_{FRP(q)}^{j_o}$ at the j_o -th aerial platform according to

$$SINR_{FRP(q)}^{j_o} = \frac{P_{i_o j_o k_o} B_{i_o j_o k_o j_o} A_{i_o j_o i_o} L_{i_o j_o}}{\sum_{i, j, k, j \neq j_o, (FCH((i, j), FRP(q)) = FCH((i_o, j_o), FRP(q)))} P_{ijk} B_{ijk, j_o} A_{i_o j_o, i} L_{ij} + I_{i_o j_o, Ext} + W_{i_o j_o} N_o} \quad (7)$$

where i_o and k_o are the indices of the cell site and the beam with which aerial platform j_o is communicating. The numerator of equation (7) is the received desired signal power at the aerial platform, and the denominator of (7) is the sum of all interfering beam received powers plus the thermal noise floor power $W_{ij} N_o$. The $(FCH((i, j), FRP(q)) = FCH((i_o, j_o), FRP(q)))$ restriction in the summation in (7) ensures that only the interference from interfering beams using the same frequency channel as the aerial platform under consideration is included in the total interference. The computed SINRs from equation (7) are used to estimate the achievable data rate at each aerial platform, and compute a network performance metric that is a function of the data rates received by the aerial platforms, to find the optimal assignment and its associated frequency reuse pattern.

Let $DR(i, j)$ denote the data rate on the cell site i to aerial platform j link, and $\{DR(i, j)\}$ denote the set of all data rates in the network. In one embodiment, the network performance optimization metric for a given aerial platform to cell site assignment, and its associated frequency reuse pattern, is a certain function, $f(\{DR(i, j)\})$, of data rates received at the aerial platforms. In one embodiment, the data rates, $DR(i, j)$, are estimated using the Shannon bound approach. One network performance metric is the total network throughput defined as the sum of data rates from cell sites to the aerial platforms. Another network throughput criterion is the sum of the network throughput on forward link over all

links, as well as overall reverse links. A network performance optimization scheme which only maximizes the network throughput may result in an assignment $APCS(\{(i, j)\}, FRP(q))$ which results in a large variation between data rates received at the different aerial platforms. An optimization metric which maximizes the network throughput subject to a constraint on a minimum data rate at each aerial platform, and a minimum data rate on at each cell site receiver, would result in an assignment that is fair in the sense of reducing variation in data rates to different aerial platforms. Note that the aerial platform to cell site assignment determination may be carried out offline, and once the process of the assignment determination is completed, then the aerial platforms will be informed of their assignments via messages sent in the FL-BCH frames.

In one embodiment, the first aerial platform j is assigned to a cell site i from which it receives the highest SINR, where SINR is computed using equation (7) while accounting for the external interference term $I_{ij, Ext}$. Note that since the external interference, $I_{ij, Ext}$, is explicitly included in the SINR computation in equation (7), then the assignment algorithm will automatically exclude cell sites from whose direction the aerial platform will receive excessive external interference, thereby avoiding external interference. In one embodiment, the NC stores measured $I_{ij, Ext}$ values and the position location coordinates of the aerial platform where the measurement is made, and looks up the stored values when calculating (7). As will be described below, in some embodiments assignment of aerial platforms will be optimized using SINR measurements at the aerial platform. An iterative procedure for optimizing the aerial platform to cell site assignment and associated frequency reuse pattern, and adding a new active mode aerial platform to the network, is carried out according to the following 2 steps.

1. Let $APCS(\{(i, j)\}, FRP(q))$ be the latest aerial platform to cell site assignment, referred to as the current assignment. In this step, an assignment optimality test is iteratively carried out for each aerial platform, one at a time, whereby a new assignment is tested by reassigning an aerial platform, and if the new assignment has higher network performance it replaces the current assignment. Let j_{test} denote the index of the aerial platform which is being reassigned. j_{test} is chosen from the list of all active aerial platforms in some sequence, such as round robin, as long as all aerial platforms are tested at least once during a certain time interval. Aerial platform j_{test} is reassigned to find a new assignment with higher network performance metric as described next. Let Z be the number of cell sites in the set $CS(j_{test})$, and i_z denote the index of the cell sites in the set $CS(j_{test})$, $1 < z < Z$. Generate Z temporary assignments as follows: for each cell site i_z in the set $CS(j_{test})$, generate a temporary assignment $temp\{\{(i, j), j \neq j_{test}\}, (i_z, j_{test})\}$ that contains the assignments from the current assignment for all aerial platforms $j \neq j_{test}$ and a new link from aerial platform j_{test} to cell site i_z , compute the aerial platform data rates (using SINR estimates from equation (7)) and the corresponding network performance metric function value for the set $temp\{\{(i, j), j \neq j_{test}\}, (i_z, j_{test})\}$ and all possible frequency reuse patterns for the set $temp\{\{(i, j), j \neq j_{test}\}, (i_z, j_{test})\}$, generate a new assignment by associating the frequency reuse pattern with the highest computed performance metric value with assignment $temp\{\{(i, j), j \neq j_{test}\}, (i_z, j_{test})\}$ and save the assignment and its corresponding performance metric value. From among the Z saved temporary assignments $temp\{\{(i, j), j \neq j_{test}\}, (i_z, j_{test})\}$

and their associated frequency reuse patterns, choose the one with the highest computed network performance metric value to be the candidate replacement assignment. If the performance of the candidate replacement assignment is higher than that of the current assignment, then the candidate assignment will replace the current assignment. If a new aerial platform is transitioning into active mode then go to step 2, otherwise repeat step 1.

2. Let $APCS(\{(i,j)\}, FRP(q))$ be the latest current assignment, and j_{new} denote the index of the new aerial platform. Let Z be the number of cell sites in the set $CS(j_{new})$, and i_z denote the index of the cell sites in the set $CS(j_{new})$, $1 < z < Z$. Generate Z temporary assignments as follows: for each cell site i_z in the set $CS(j_{new})$, generate a temporary assignment $temp\{\{(i,j)\}, (i_z, j_{new})\}$ that contains the assignments from the latest assignment and a new link from aerial platform j_{new} to cell site i_z , compute the aerial platform data rates (using SINR estimates from equation (7)) and the corresponding network performance metric function value for the set $temp\{\{(i,j)\}, (i_z, j_{new})\}$ and for all possible frequency reuse patterns for the set $temp\{\{(i,j)\}, (i_z, j_{new})\}$ generate a new assignment by associating the frequency reuse pattern with the highest computed performance metric value with assignment $temp\{\{(i,j)\}, (i_z, j_{new})\}$ and save the assignment and its corresponding performance metric value. From among the Z saved temporary assignments $temp\{\{(i,j)\}, (i_z, j_{new})\}$ and their associated frequency reuse pattern, choose the one with the highest computed network performance metric as the new current assignment. If there is no new aerial platform to be added go to step 1, otherwise repeat step 2.

As mentioned previously, when the aerial platform and cell site antenna beams have narrow beamwidths, then a small number of cell site beams interfere with the new aerial platform being added or with the aerial platform which is being reassigned. Then, when determining the optimal frequency reuse pattern at an iteration, the frequency reuse order for the beams whose crossbeam interference change by more than a certain threshold after the addition or reassignment of an aerial platform need to be optimized. In one embodiment, the optimal frequency reuse pattern is obtained by creating a list of different frequency reuse patterns for a subset of the beams whose crossbeam interference change by more than a certain threshold after the addition or reassignment of an aerial platform, and evaluating the performance metric value of the frequency reuse patterns in the said list to determine the frequency reuse pattern with the highest performance metric value. In other words, the frequency reuse pattern optimization may be carried out in a localized manner by focusing on a subset of the beams that are affected by the new addition, thereby reducing the optimization computation time.

As aerial platforms move, the cell site to aerial platform assignment may no longer be optimal. Therefore, the assignment needs to be periodically recomputed according to the same procedures described above. As an example, if the cell site beam beamwidth is 3° and an aircraft is at a distance of 100 km from the cell site, then the distance covered by the beam's beamwidth is about 5 km around the aircraft. Suppose the two aircraft are traveling parallel to the same sell site and in opposite directions as in FIG. 6A, and at a given time the peak of the cell site beams covering the two aircraft is 4° apart, for which the crossbeam interference is small and the two beams use the same frequency channel without

excessive crossbeam interference. In this case, in about 3 seconds the peaks of the two cell site beams tracking the aircraft travelling in opposite directions and parallel to a cell site, at distance of 100 km from the cell site, and at speed of 1000 km/hour become 3° apart. When the spacing between the peaks of the two beams goes below the beams' beamwidth, then frequency reuse order of 2 may have higher performance. Step 1 of the above assignment optimization algorithm will automatically reassign and change the frequency reuse pattern of the beams as two aerial platforms approach as mentioned.

Once an aerial platform moves out of the coverage area of the sector with which it is associated and moves into the coverage area of an adjacent sector, then since the cell site beam is still pointing toward the same aerial platform only the function of forming the beam needs to be handed off to the adjacent sector antenna sub-system. In cases of handoff to a different cell site, the cell site to which the aerial platform is handed off is chosen using the same methodology used in assigning aerial platforms to cell sites described in the above iteration. If the data rate of the aerial platform may be enhanced by handing off to another cell site, then the iteration described above for improving the data rates of aerial platforms will automatically handoff the aerial platforms to improve their data rates.

In the above embodiments for assigning aerials platforms to cell sites, the received SINRs and achieved data rates at the aerial platforms were used as the performance metric to evaluate the different assignments. However, the network must verify that for the chosen cell site to aerial platform assignment the cell site receivers for the corresponding assignment also receive adequate data rate. In one embodiment, the SINR received from each aerial platform j_o at the cell site i_o on beam k_o is estimated according to

$$SINR = \frac{P_{aj_o} B_{i_o j_o k_o j_o} A_{i_o j_o i_o} L_{i_o j_o}}{\sum_{j, j \neq j_o, (FCH((i,j), FRP(q)) = FCH((i_o, j_o), FRP(q)))} P_{aj} B_{i_o j_o k_o j} A_{ij i_o} L_{i_o j} + I_{i_o k_o, Ext} + W_{i_o j_o} N_o} \quad (9)$$

the data rate achievable for the corresponding SINR is computed, and if the computed data rate is below a threshold, i_o is removed from the set $CS(j_o)$, and a new assignment is generated according to the above embodiments using the new sets $CS(j_o)$. This process is continued until an assignment that optimizes the specified network performance criterion and also meets the return link data rate requirement, is found.

In the above embodiments for assigning aerial platforms to cell sites, received SINR at the aerial platform receivers were used to compute data rates, and the network performance metric was defined to be a function of aerial platform data rates. However, a person of ordinary skill in the art will readily recognize that received SINRs at the cell sites, or a combination of the SINRs at the aerial platform and at the cell sites may also be used as the signal quality metric in assigning aerial platforms to cell sites, without departing from the scope of the disclosure. Moreover, signal quality metrics other than SINR, and other network performance metric functions, may also be used in the above embodiments without departing from the scope of the disclosure.

What is claimed is:

1. A system to provide broadband access to aerial platforms, comprising:
 - a network of cell sites, each cell site composed of at least one sector, each sector equipped with a sector commu-

nications equipment comprising a processor, L cell site radio modules per sector and L antenna apertures per sector, wherein L is an integer greater than 1;
 each antenna aperture comprising a number of antenna elements and configured to form at least one steerable beam per sector;
 each cell site radio module transmits on only one antenna aperture and receives from all L antenna apertures;
 a plurality of aerial platforms that each comprise an aerial platform communications equipment comprising a radio sub-system and an antenna sub-system, the antenna sub-system comprising at least one antenna aperture forming at least one steerable beam; and
 each sector communications equipment configured to: divide each of N, an integer, data packet streams destined to N different aerial platforms into L data packet sub-streams;
 use L cell site radio modules, one cell site radio module is dedicated to transmit on one antenna aperture;
 transmit each of the L data packet sub-streams destined to an aerial platform on a different antenna aperture;
 transmit all N data packet streams on all the antenna apertures in a sector; and
 transmit on a different and only one frequency channel or polarization on each antenna aperture.

2. System of claim 1, wherein an available spectrum is divided into L frequency channels.

3. System of claim 1, wherein L is an even integer, a first polarization of a first half of the antenna apertures and a second polarization of a second half of the antenna apertures are used for data transmission.

4. System of claim 3, wherein an available spectrum is divided into L/2 frequency channels.

5. System of claim 1, wherein each antenna aperture comprises two polarizations and both polarizations of each antenna aperture are used for data transmission.

6. System of claim 1, wherein the sector communications equipment is further configured to:
 encode and modulate a data packet to generate a digital IQ sample stream;
 generate a plurality of beamforming digital IQ sample streams, one for each antenna element of each antenna aperture; and
 send each beamforming digital IQ sample stream to one of the antenna elements of one of the antenna apertures.

7. The system of claim 1, wherein the aerial platform communications equipment is further configured to:

receive a data packet stream from upper layer protocols; split the data packet stream into multiple data packet sub-streams;
 encode and modulate each data packet sub-stream separately; and
 transmit each encoded data packet sub-stream on a different antenna aperture and a different frequency channel.

8. The system of claim 1, wherein the sector communications equipment is further configured to:
 receive a plurality of RF signals, one RF signal from each antenna element of each antenna aperture;
 generate a plurality of digital IQ sample streams from the plurality of RF signals;
 send the digital IQ sample streams corresponding to each frequency channel and antenna polarization to a different cell site radio module;
 combine the digital IQ sample streams at the at least one cell site radio module into a single digital IQ sample stream, demodulate and decode the single digital IQ sample stream to recover a data packet sub-stream; and
 combine the data packet sub-streams recovered from at least two cell site radio modules into a single data packet stream.

9. The system of claim 8, wherein the digital IQ sample streams are combined such as to maximize a signal quality metric for the single digital IQ sample stream.

10. The system of claim 9, wherein the signal quality metric is a received SINR.

11. System of claim 1, wherein the sector communications equipment is configured to:
 divide a sector coverage area into a number of sub-sectors; and
 form a beam toward each sub-sector.

12. System of claim 11, wherein the aerial platform communications equipment is configured to:
 form a beam toward a first sub-sector beam;
 measure a signal quality metric on the first sub-sector beam and on a second sub-sector beam adjacent to the first sub-sector beam; and
 point the beam toward the second sub-sector beam if the signal quality metric on the second sub-sector beam is higher than the signal quality metric on the first sub-sector beam.

* * * * *