



US010555034B2

(12) **United States Patent**  
**Martel et al.**

(10) **Patent No.:** **US 10,555,034 B2**  
(45) **Date of Patent:** **\*Feb. 4, 2020**

(54) **DIGITAL VIDEO RECORDER WITH  
ADDITIONAL VIDEO INPUTS OVER A  
PACKET LINK**

(71) Applicant: **Verint Americas Inc.**, Alpharetta, GA  
(US)

(72) Inventors: **Hugo Martel**, Montreal (CA); **Charles  
Gregory Lampe**, Silver Spring, MD  
(US); **Louis Marchand**, Montreal  
(CA); **Jim Moran**, Annapolis, MD (US)

(73) Assignee: **Verint Americas Inc.**, Alpharetta, GA  
(US)

(\*) Notice: Subject to any disclaimer, the term of this  
patent is extended or adjusted under 35  
U.S.C. 154(b) by 0 days.

This patent is subject to a terminal dis-  
claimer.

(21) Appl. No.: **16/024,202**

(22) Filed: **Jun. 29, 2018**

(65) **Prior Publication Data**

US 2018/0332344 A1 Nov. 15, 2018

**Related U.S. Application Data**

(63) Continuation of application No. 13/041,594, filed on  
Mar. 7, 2011, now Pat. No. 10,028,018.

(60) Provisional application No. 61/311,283, filed on Mar.  
5, 2010.

(51) **Int. Cl.**

**H04N 21/44** (2011.01)  
**H04H 60/59** (2008.01)

(52) **U.S. Cl.**  
CPC ..... **H04N 21/44008** (2013.01); **H04H 60/59**  
(2013.01)

(58) **Field of Classification Search**  
CPC ..... **H04N 21/44008**; **H04N 7/18**; **H04N**  
**21/2747**; **H04H 60/59**  
See application file for complete search history.

(56) **References Cited**

U.S. PATENT DOCUMENTS

5,862,342 A 1/1999 Winter et al.  
6,226,384 B1 5/2001 Cavallerano et al.  
2001/0012383 A1\* 8/2001 Kawai ..... G06F 3/121  
382/114  
2002/0003948 A1 1/2002 Himeno et al.  
(Continued)

*Primary Examiner* — Thai Q Tran

*Assistant Examiner* — Sunghyoun Park

(74) *Attorney, Agent, or Firm* — Christopher M. Scherer;  
DeWitt LLP

(57) **ABSTRACT**

What is disclosed is a video system. The video system includes a digital video recorder comprising a first camera interface configured to receive video captured from a first plurality of cameras, a packet interface configured to receive in a packet format video captured by a second plurality of cameras, and a storage system configured to store the video captured by the first plurality of cameras and the video captured by the second plurality of cameras. The video system also includes a video encoder coupled to the digital video recorder by a packet link, where the video encoder includes a second camera interface configured to receive video captured from the second plurality of cameras and an output interface configured to transfer in the packet format the video captured by the second plurality of cameras for delivery to the digital video recorder over the packet link.

**19 Claims, 4 Drawing Sheets**

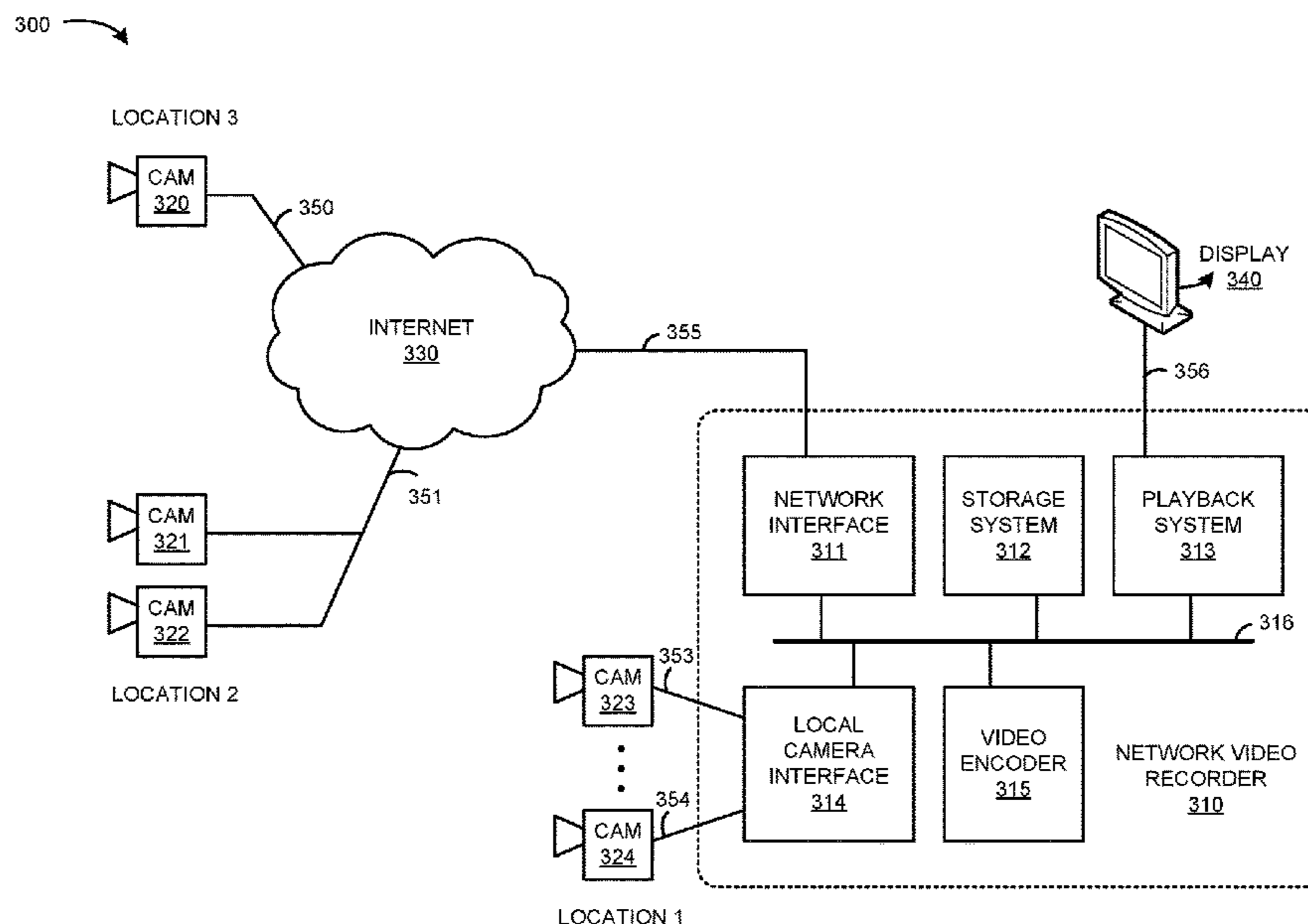

(56)

**References Cited**

U.S. PATENT DOCUMENTS

2002/0018117	A1	2/2002	Tosaya	
2002/0071654	A1*	6/2002	Notoya .....	H04N 9/8042 386/331
2002/0141732	A1	10/2002	Reese et al.	
2003/0142745	A1	7/2003	Osawa	
2003/0223733	A1	12/2003	Chang	
2004/0128317	A1*	7/2004	Sull .....	G11B 27/034
2004/0156623	A1	8/2004	Kato et al.	
2004/0184531	A1	9/2004	Lim et al.	
2005/0276264	A1	12/2005	Cordero et al.	
2006/0092938	A1*	5/2006	Gentrix .....	H04L 29/06 370/390
2006/0184553	A1	8/2006	Liu et al.	
2006/0200845	A1	9/2006	Foster et al.	
2006/0236338	A1*	10/2006	Shimoda .....	G11B 27/105 725/37
2006/0238648	A1*	10/2006	Wogsberg .....	H04N 7/01 348/441
2007/0024705	A1	2/2007	Richter et al.	
2008/0151884	A1	6/2008	Elberbaum	
2008/0184245	A1	7/2008	St-Jean	
2008/0184316	A1	7/2008	Mori et al.	
2008/0235742	A1*	9/2008	Osaki .....	H04N 21/2387 725/100
2009/0185792	A1*	7/2009	Braunstein .....	H04N 5/77 386/239
2009/0245268	A1	10/2009	Pugliese, IV	
2010/0097473	A1	4/2010	Park et al.	
2011/0058035	A1	3/2011	DeBerry et al.	

\* cited by examiner

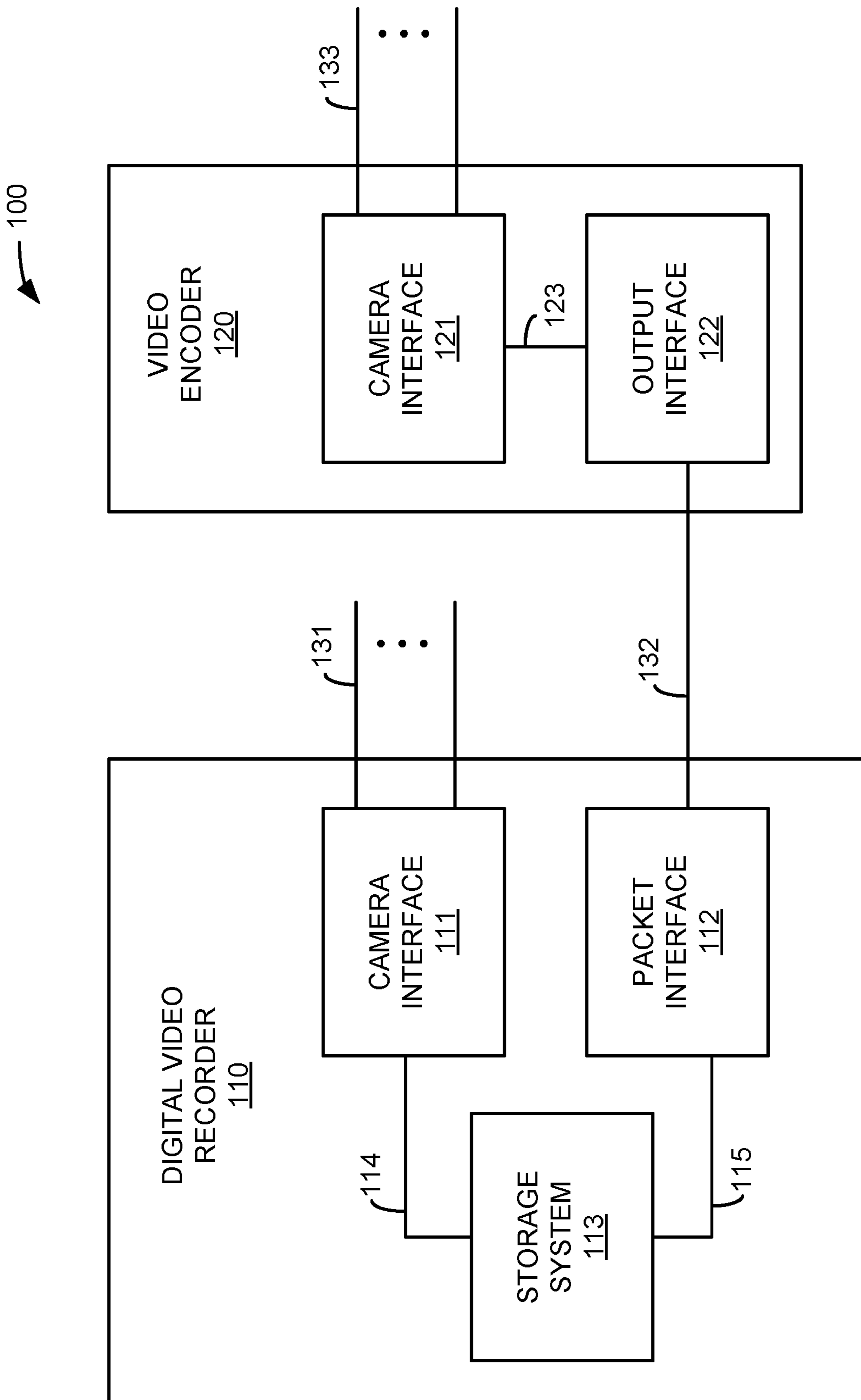
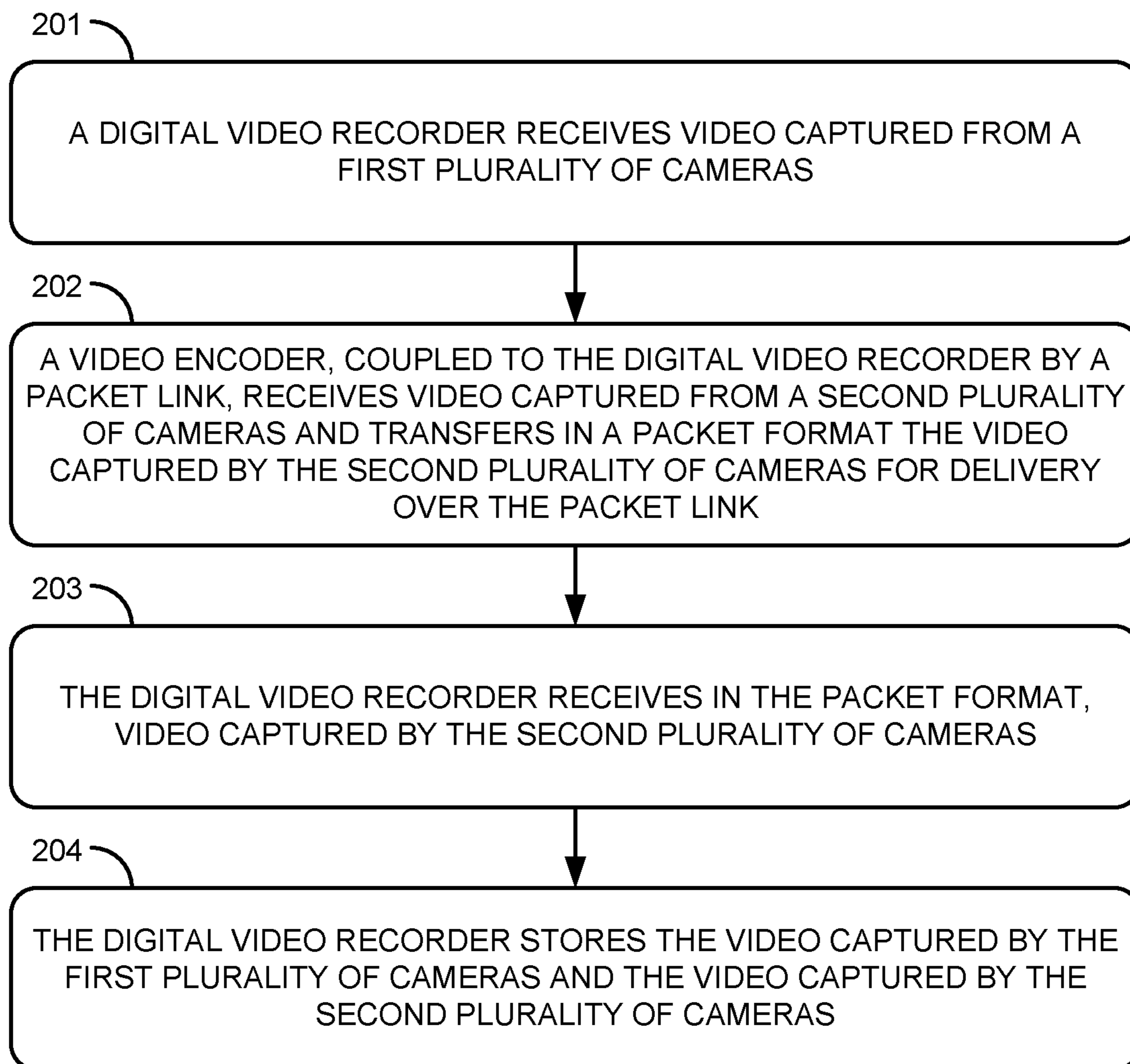

FIGURE 1

**FIGURE 2**

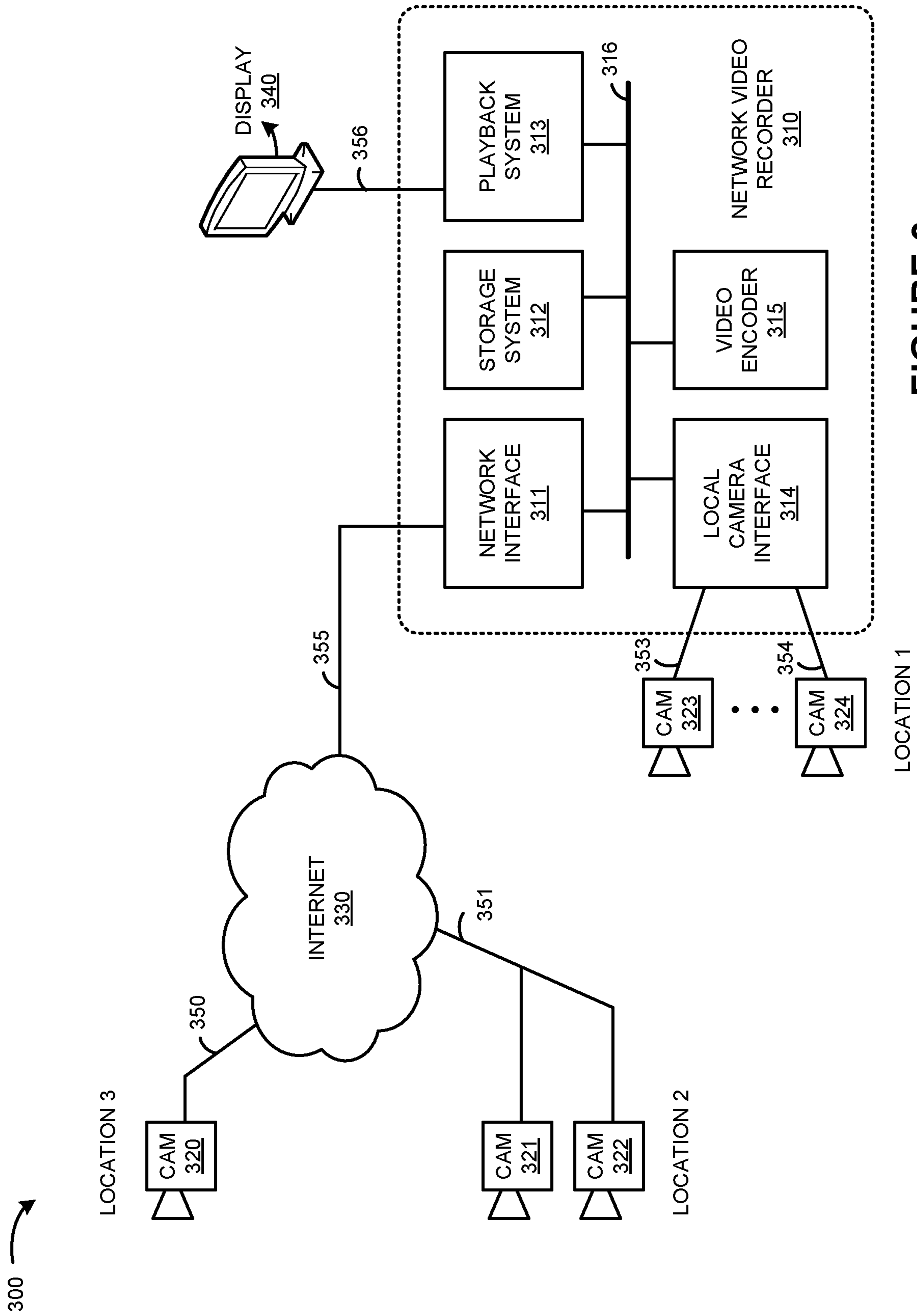
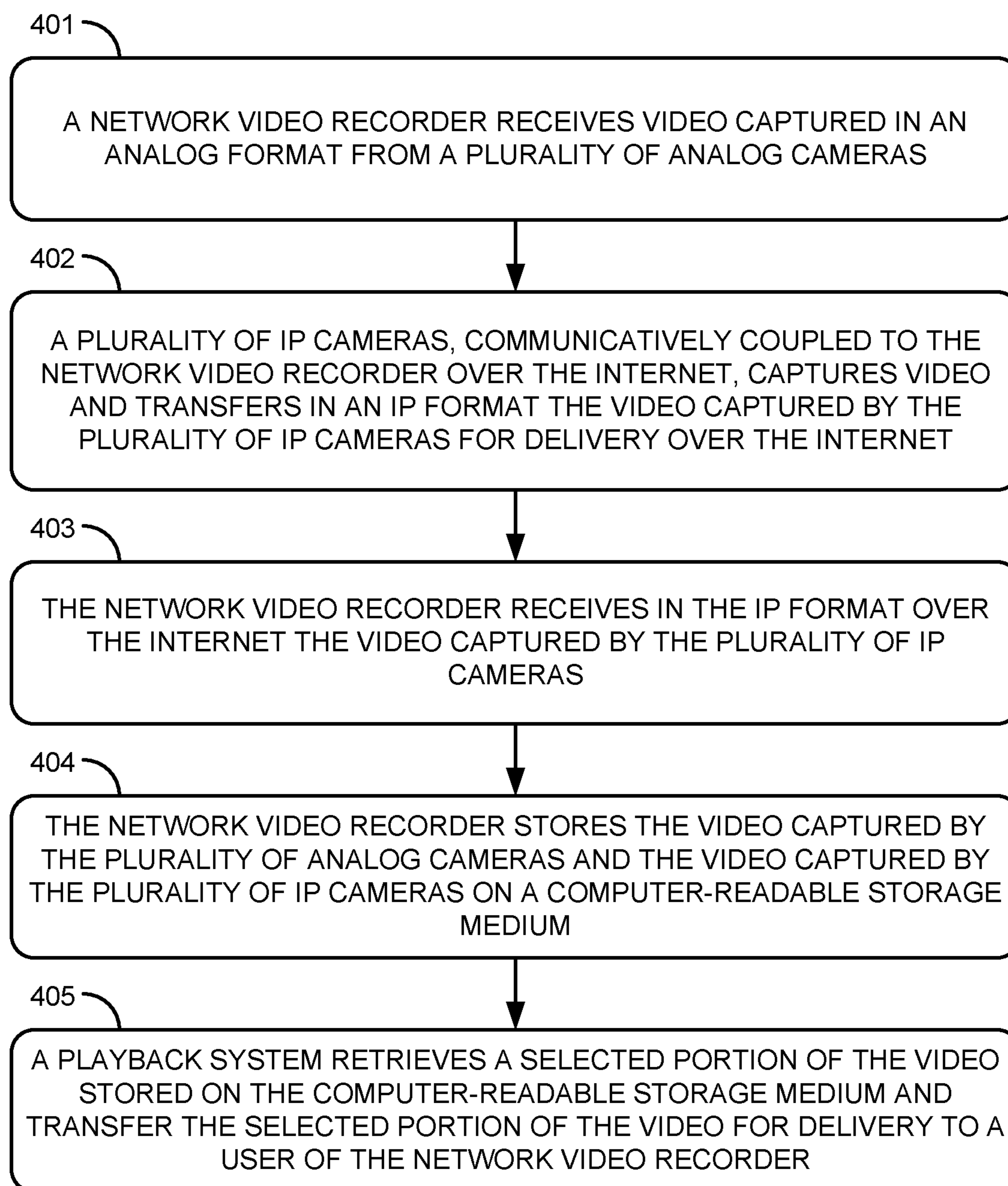

FIGURE 3

**FIGURE 4**

1

## DIGITAL VIDEO RECORDER WITH ADDITIONAL VIDEO INPUTS OVER A PACKET LINK

### RELATED APPLICATIONS

This patent application is a continuation of U.S. application Ser. No. 13/041,594, filed Mar. 7, 2011, which application claims priority to U.S. Provisional Patent Application No. 61/311,283, filed Mar. 5, 2010, the contents of which are incorporated by reference in their entireties.

### TECHNICAL FIELD

Aspects of the disclosure are related to the field of communications, and in particular, digital video processing and digital video recording devices operating over packet links.

### TECHNICAL BACKGROUND

Digital video recorders capture video from video sources such as video cameras or television sources. In some examples, a digital video recorder is employed for video surveillance, and uses locally connected analog video cameras to capture video. The video captured from the video sources is typically stored on an internal storage system, such as a hard disk drive, for later retrieval by a user of the digital video recorders. However, digital video recorders used for video surveillance rely on analog video cameras connected locally to the digital video recorder, and thus are limited by cable lengths, signal attenuation, interference, and other factors of video signals. Thus, video surveillance conducted using these digital video recorders is typically limited to a single premises or building.

#### Overview

What is disclosed is a video system. The video system includes a digital video recorder comprising a first camera interface configured to receive video captured from a first plurality of cameras, a packet interface configured to receive in a packet format video captured by a second plurality of cameras, and a storage system configured to store the video captured by the first plurality of cameras and the video captured by the second plurality of cameras. The video system also includes a video encoder coupled to the digital video recorder by a packet link, where the video encoder includes a second camera interface configured to receive video captured from the second plurality of cameras and an output interface configured to transfer in the packet format the video captured by the second plurality of cameras for delivery to the digital video recorder over the packet link.

What is also disclosed is a method of operating a video system. The method includes, in digital video recorder, receiving video captured from a first plurality of cameras, receiving in a packet format video captured by a second plurality of cameras, and storing the video captured by the first plurality of cameras and the video captured by the second plurality of cameras. The method also includes, in a video encoder coupled to the digital video recorder by a packet link, receiving video captured from the second plurality of cameras and transferring in the packet format the video captured by the second plurality of cameras for delivery to the digital video recorder over the packet link.

### BRIEF DESCRIPTION OF THE DRAWINGS

Many aspects of the disclosure can be better understood with reference to the following drawings. The components

2

in the drawings are not necessarily to scale, emphasis instead being placed upon clearly illustrating the principles of the present disclosure. Moreover, in the drawings, like reference numerals designate corresponding parts throughout the several views. While several embodiments are described in connection with these drawings, the disclosure is not limited to the embodiments disclosed herein. On the contrary, the intent is to cover all alternatives, modifications, and equivalents.

FIG. 1 is a system diagram illustrating a video system.

FIG. 2 is a flow diagram illustrating a method of operation of a video system.

FIG. 3 is a system diagram illustrating a video system.

FIG. 4 is a flow diagram illustrating a method of operation of a video system.

### DETAILED DESCRIPTION

FIG. 1 is a system diagram illustrating video system **100**. Video system **100** includes digital video recorder (DVR) **110** and video encoder **120**. Digital video recorder **110** and video encoder **120** communicate over packet link **132**. Digital video recorder **110** includes camera interface **111**, packet interface **112**, and storage system **113**. Camera interface **111** and storage system **113** communicate over link **114**. Packet interface **112** and storage system **113** communicate over link **115**. Video encoder **120** includes camera interface **121** and output interface **122**. Camera interface **121** and output interface **122** communicate over link **123**.

FIG. 2 is a flow diagram illustrating a method of operating video system **100**. The operations of FIG. 2 are referenced herein parenthetically. In FIG. 2, DVR **110** receives (201) video captured from a first plurality of cameras. In this example, camera interface **111** of DVR **110** receives and processes video from a plurality of cameras over links **131**. In some examples, camera interface **111** receives analog video from cameras in an analog format, such as NTSC, PAL, RGB, or other analog video format. In examples where analog video is received from the cameras, camera interface **111** could encode the analog video into a digital format. In further examples, camera interface **111** could compress or encrypt the video into a digital format. In other examples, camera interface **111** receives digital video from cameras in a digital format, such as MPEG, H.264, JPEG video, or other digital video format. Although camera interface **111** receives video from cameras in this example, the cameras are not included in FIG. 1 for clarity. It should be understood that camera interface **111** receive video over links **131**, respectively, from any number of cameras. In some examples, 16 cameras are coupled to camera interface **111**, although a different number of cameras could be employed. The associated cameras could communicate with camera interface **111** over coaxial, wireline, wireless, optical, or other signaling media, including combinations thereof.

Video encoder **120** receives (202) video captured from a second plurality of cameras and transfers in a packet format the video captured by the second plurality of cameras for delivery over packet link **132**. In this example, video encoder **120** and DVR **110** are coupled by packet link **132**. Camera interface **121** of video encoder **120** receives and processes video from a plurality of cameras over links **133**. In some examples, camera interface **121** receives analog video from cameras in an analog format, such as NTSC, PAL, RGB, or other analog video format. In examples where analog video is received from the cameras, camera interface **121** could encode the analog video into a digital format. In further examples, camera interface **121** could compress or

encrypt the video into a digital format. In other examples, camera interface **121** receives digital video from cameras in a digital format, such as MPEG, H.264, JPEG video, or other digital video format. Although camera interface **121** receives video from cameras in this example, the cameras are not included in FIG. **1** for clarity. It should be understood that camera interface **121** receive video over links **133**, respectively, from any number of cameras. In some examples, 16 cameras are coupled to camera interface **121**, although a different number of cameras could be employed. The associated cameras could communicate with camera interface **121** over coaxial, wireline, wireless, optical, or other signaling media, including combinations thereof.

Output interface **122** receives video from camera interface **121** over link **123**. In some examples, output interface **122** processes analog video received from camera interface **121** into a digital format, and processes the video in the digital format into a packet format for transfer over packet link **132** for delivery to DVR **110**. In other examples, output interface **122** receives the video in a digital format from camera interface **121**, and processes the video in the digital format into a packet format for transfer over packet link **132** for delivery to DVR **110**. The packet format over which the video captured by the second plurality of cameras is transferred could include an Internet protocol (IP) packet format or an Ethernet packet format, among other packet formats, including combinations thereof.

DVR **110** receives (203) in the packet format video captured by the second plurality of cameras. Packet interface **112** of DVR **110** receives the video in the packet format over packet link **132**. Packet link **132** could include an IP link, Ethernet link, or other packet link, and could be transported over a packet network, such as a local area network (LAN) or the Internet, among other networks. Packet interface **112** then transfers the video received over packet link **132** over link **115** to storage system **113**. Although in this example, the video received in the packet format is captured by cameras associated with camera interface **121** of video encoder **120**, and transferred in a packet format by output interface **122** of video encoder **120** over packet link **132**, in further examples, DVR **110** could include multiple packet interfaces for receiving video from multiple video encoders.

DVR **110** stores (204) the video captured by the first plurality of cameras and the video captured by the second plurality of cameras. The video captured by the first plurality of cameras is transferred by camera interface **111** over link **114** to storage system **113**. In some examples, storage system **113** receives analog video from camera interface **111** and video in a packet format from packet interface **112**. In other examples, storage system **113** receives digital video from camera interface **111** and video in a packet format from packet interface **112**. In further examples, storage system **113** digitizes analog video received from camera interface **111**. In yet further examples, storage system **113** changes the format, frame rate, or resolution of the video received from camera interface **111** or the video received in the packet format from packet interface **112** before storing the video on the storage media.

FIG. **3** is a system diagram illustrating video system **300**. Video system **300** includes network video recorder (NVR) **310**, cameras **320-324**, Internet **330**, and display **340**. NVR **310** and Internet communicate over packet link **355** which is an Internet protocol (IP) link in this example. NVR **310** and display **340** communicate over link **356** which is a VGA graphics link in this example. NVR **310** and cameras **323-324** communicate over analog NTSC links **353-354**, respectively. Camera **320** and Internet **330** communicate over link

**350**, which is an IP link in this example. Cameras **321-322** and Internet **330** communicate over link **351**, which is an IP link in this example. It should be understood that links **316** and **350-356** could employ similar features as links **114-115**, **123**, and **131-133** in FIG. **1**.

NVR **310** includes network interface **311**, storage system **312**, playback system **313**, local camera interface **314**, video encoder **315**, and bus **316**. NVR **310** could be an example of DVR **110** in FIG. **1**, although DVR **110** could use other configurations. Network interface **311** comprises a network interface card (NIC) and associated transceiver circuitry for communicating over a packet link, such as IP link **355**. In further examples, network interface **311** could include an RJ-45, Ethernet 10/100/1000 Base-T, or other network interface. Storage system **312** includes a computer-readable storage medium, which could include a hard disk drive, a solid state drive, an array of drives, optical drives, a universal serial port (USB) storage device, or a redundant array of independent disks (RAID) system. In further examples, storage system **312** includes circuitry for a local or remotely managed video export on a USB key or a DVD-RW. Playback system **313** includes circuitry to display video captured by video cameras or stored on storage system **312** to a user of NVR **310**. Playback system **313** could include a VGA, DVI, NTSC, PAL, RGB, BNC, or other video interface or format, and could provide video live video playback of the video captured by the various video cameras. Playback system **313** could provide both live video and stored video simultaneously to a user of NVR **310**. Local camera interface **314** includes circuitry and equipment to interface with analog video cameras in an NTSC format, and could include impedance matching circuitry, filters, amplifiers, transceivers, and cable connectors. Video encoder **315** includes circuitry to convert the video received in an analog format by local camera interface **314** to a digital format for storage in storage system **312**. Video encoder **315** includes analog-to-digital conversion circuitry, amplifiers, filters, buffers, or other video processing circuitry. Bus **316** includes a common bus for communications between the elements of NVR **310**, which could include elements for transferring video data, power, control signals, or other information.

Cameras **320-322** comprise IP cameras in this example. Cameras **320-322** capture video in an analog format and convert the video in the analog format to video in a digital format. The video in the digital format is then packetized by the associated one of cameras **320-322**, and transferred for delivery over the associated packet link **350-351**. The analog format could include NTSC, PAL, RGB, analog CIF, or another analog format, including combinations, improvements, or variations thereof. The digital format could include MPEG, H.264, JPEG video, digital CIF, or some other digital video format, including combinations, improvements, or variations thereof. In this example, each of cameras **320-322** include a camera interface and output interface, such as described for video encoder **120** in FIG. **1**. Cameras **320-322** could be video cameras associated with automated teller machines (ATM), point-of-sale (PoS) devices, bank teller locations, or alarm systems, among other locations and equipment.

Cameras **323-324** comprise analog video cameras in this example. Cameras **323-324** capture video in an analog format and transfer the video over electrical signals, such as a BNC connector or coaxial cable link carrying NTSC signals. Although the analog format in this example is the NTSC format, in other examples the analog format could include PAL, RGB, analog CIF, or another analog format, including combinations, improvements, or variations



thereof. It should be understood that cameras **323-324** could capture video in a digital format, such as using a CCD image sensor, CMOS image sensor, or megapixel sensor, and convert the captured image data into an analog format or a digital format as described herein. Cameras **323-324** could include video cameras associated with automated teller machines (ATM), point-of-sale (PoS) devices, bank teller locations, or alarm systems, among other locations and equipment. NVR **310** could provide power for cameras **323-324** over links **353-354**.

FIG. **4** is a flow diagram illustrating a method of operating video system **300**. The operations in FIG. **4** are referenced herein parenthetically. In FIG. **4**, network video recorder (NVR) **310** receives (**401**) video captured in an analog format from a plurality of analog cameras. In this example, the plurality of analog cameras includes cameras (CAM) **323-324**. A different number of analog-output video cameras could be employed. In this example, the video is captured by each of cameras **323-324** by an image sensor and converted into an analog format for delivery over the associated video link **353-354**. Local camera interface **314** receives the video in the analog format over video links **353-354** and transfers the video for delivery to video encoder **315** over bus **316**. Local camera interface **314** could process the analog video, such as by amplifying, filtering, reconditioning, or attenuating the video in the analog format. In some examples, local camera interface **314** transfers the video directly to video encoder **315** over analog signal lines, and does not transfer the analog video over bus **316**. Once the video in the analog format is received by video encoder **315**, video encoder **315** converts the video in the analog format to video in a digital format, where the digital format could include any of the digital formats discussed herein. In further examples, video encoder **315** comprises a video encoder integrated circuit or circuits, which could include analog-to-digital converters, amplifiers, filters, buffers, compression circuitry, encryption circuitry, or other circuitry. Video encoder **315** then transfers the video in the digital format over bus **316** for delivery to storage system **312** or playback system **313**.

A plurality of IP cameras, communicatively coupled to NVR **310** over Internet **330**, captures (**402**) video and transfer in an IP format the video captured by the plurality of IP cameras for delivery over Internet **330**. In this example, the plurality of IP cameras includes cameras (CAM) **320-322**. A different number of IP video cameras could be employed. In this example, the video is captured by each of cameras **320-322** by an image sensor and converted into an IP format for delivery over the associated IP link **350-351**. In this example, camera **321** and camera **322** share an IP link, namely IP link **351**. The video in the IP format captured by each of cameras **321-322** could be combined into a single IP link using a network hub, switch, server, or router. The video in the IP format transferred by each of cameras **320-322** is transported over Internet **330** for receipt by network interface **311**. Appropriate network addressing, such as IP addresses, could be employed in the IP packet format to ensure delivery to network interface **311**. In some examples, tunnels could be employed over each of links **350-351** and link **355**, or between each of cameras **320-322** and network interface **311**, for transporting the video in the IP packet format over Internet **330**.

NVR **310** receives (**403**) in the IP format over Internet **330** the video captured by the plurality of IP cameras. In this example, network interface **311** receives the video in the IP format over IP link **355** and transfers the video for delivery to storage system **312** or playback system **313** over bus **316**. In some examples, network interface **311** converts the video

in the IP format to another format, such as a non-packet format or digital format as discussed herein. In further examples, network interface **311** includes buffer circuitry to reduce jitter or breaks in the receipt of the IP video over link **355**. Network interface **311** could include a programmable packet throttling feature which would limit the packet quantity or bandwidth for each video camera over link **355**.

NVR **310** stores (**404**) the video captured by the plurality of analog cameras and the video captured by the plurality of IP cameras on a computer-readable storage medium. In this example, storage system **312** receives video from video encoder **315** and from network interface **311** that was captured by the associated video cameras. Storage system **312** includes a computer-readable storage medium in this example, such as a hard disk drive, solid-state memory device, optical storage system, or other computer-readable media, and could include an array of computer-readable storage media, such as a RAID array. Storage system **312** could receive the video in different digital video formats, packet formats, or other video formats, and store the video as received on the computer-readable storage medium. In other examples, storage system **312** changes the format of the video into a common video format, a non-packet format, or other digital format as discussed herein prior to storage on the computer-readable storage medium. Storage system **312** could include other data with the stored video, such as metadata including timestamps, time codes, camera identifiers, video format information, camera location information, trigger information, alert information, or camera scene information, among other information. Storage system **312** could allow a user of NVR **310** to set different resolutions, frame rates, and image retention features of the video prior to storage on the computer-readable medium. The features could be selected by a user of NVR **310** over a user interface as discussed herein.

Playback system **313** retrieves (**405**) a selected portion of the video stored on the computer-readable storage medium and transfers the selected portion of the video for delivery to a user of NVR **310**. Playback system **313** communicates with storage system **312** to access the video stored on the computer-readable medium of storage system **312**. Storage system **312** retrieves the video stored on the computer-readable medium and transfers the video over bus **316** for delivery to playback system **313**. Playback system **313** receives the video and transfers the video for display to a user of NVR **310**. Playback system **313** could also receive metadata, such as discussed in operation **404**, for association and transfer with the video for display to a user. In this example, playback system **313** transfers the video over link **356**, which is a VGA graphics link connected to display **340**. Display **340** could comprise a television, video monitor, computer monitor, computer display, or other video display device. In further examples, a user of NVR **310** requests selected video over a user interface of NVR **310**, such as a keyboard, mouse, control panel, or other user interface associated with NVR **310** or through display **340**. Playback system **313** would responsively transfer the requested video over link **356**. In some examples, a composite view of multiple video cameras or video data could be transferred over link **356**, such as examples including four camera views. Playback system **313** could combine video data from multiple cameras or from a single camera, including video captured over multiple timeframes, into a multi-video view. Playback system **313** could incorporate the metadata into the video data for transfer over link **356**, such as including camera names, camera scenes, camera locations, time codes, or other data in the video associated with a particular video

camera. Playback system **313** could convert the video received over bus **316** into a video or display format compatible with link **356** and display **340**, such as a VGA, DVI, RGB, NTSC, PAL, or other video format. Playback system **313** could modify the video to different resolutions or frame rates for display to a user of NVR **310**.

In further examples, playback system **313** receives live video from any of network interface **311** or video encoder **315** for displaying to a user of NVR **310**. The live video could be received before the associated video is stored by storage system **312**. The live video could be transferred by any of network interface **311** or video encoder **315** in parallel with transferring the video for storage by storage system **312**. Bus **316** could carry both live video and video to be stored. Playback system **313** could transfer the live video over display link **356** for display on display **340**, and could include similar metadata information or video scene combining as discussed in operation **405** above. Playback system **313** could combine live video with video retrieved from storage system **312** into composite views for display **340**. In yet further examples, playback system **313** could retrieve video stills, such as individual video frames, images, or other video portions for display to a user of NVR **310**.

In yet further examples, NVR **310** could include a user interface, such as a control panel, keyboard, mouse, touch-screen, microphone, or other user interface for receiving command and control instructions from a user of NVR **310**. The user interface could be provided over a network link, such as over IP link **355** by network interface **311**. The user interface provides a user of NVR **310** a way to select video for viewing, to control a playback sequence of video from NVR **310**, or to specify recording and capture parameters, such as alerts, alarms, or other parameters. The user interface of NVR **310** could allow a user to find images and transactions by time, time interval (at-a-glance views), date, number, transaction, or event. Users could also search for and view video by time, date, transaction, or event. The user interface could also provide day-at-a-glance, week-at-a-glance, and motion-based searches help users quickly pinpoint video of interest. The user interface could also provide remote access to live and recorded video, system setup, and internal DVR logs for system, operational, and configuration information. NVR **310** could also include equipment and circuitry to allow enterprise-wide NVR viewing of video, such as over a network link. NVR **310** could also include triggering features, such as alarms, event-based recording, event-based triggers, or other triggers to enable recording or storage of video, alert users of NVR **310**. The event-based triggers could include settings for camera input, schedules, and recording, such as recording start/stop triggers, and could also include programmable events and scheduling, or settings for general recording, motion-triggered recording, and event-triggered recording. NVR **310** could include independent storage settings for alarms, such as using color-coded file and search structures. NVR **310** could also include audio input/output, capable of playing back pre-recorded messages. The audio input/output could also include audio input associated with the captured video, and audio output during playback of the video. The audio information could be stored along with the video, such as in a multimedia format described herein. NVR **310** could also include user controls for moving the associated video cameras according to pan, tilt, and zoom commands, such as receiving commands over a serial communications port, or other network link.

Referring back to FIG. 1, camera interfaces **111** and **121** each include circuitry and equipment to receive and process

video from a plurality of cameras. Camera interfaces **111** and **121** could each comprise transceivers, amplifiers, impedance matching circuitry, connectors, analog-to-digital converters, video processors, buffers, filters, video compression processors, video encoding processors, or other circuitry and equipment.

Packet interface **112** includes circuitry and equipment to receive video in a packet format over packet link **132**. Packet interface **112** could comprise network interface equipment such as routers, gateways, buffers, network interface cards (NIC), packet processing equipment, or other systems and equipment, including combinations thereof.

Output interface **122** includes circuitry and equipment to transfer video in a packet format over packet link **132**. Output interface **122** could comprise network interface equipment such as routers, gateways, network interface cards (NIC), buffers, packet processing equipment, or other systems and equipment, including combinations thereof.

Storage system **113** includes storage media to store video received from camera interface **111** and received from camera interface **121** through packet interface **112**. Storage system **113** could comprise a computer-readable medium such as a disk, tape, integrated circuit, server, or some other memory device, and also may be distributed among multiple memory devices.

Camera links **131** and **133** each use metal, glass, optical, air, space, or some other material as the transport media. Camera links **131** and **133** could each use various analog or digital video formats, such as NTSC, PAL, MPEG, H.264, JPEG video, or some other video format, including combinations, improvements, or variations thereof.

Links **114-115** and **123** each comprise a physical, logical, or virtual communication link, capable of communicating video, video packets, data, control signals, and communications, along with other information. In some examples, links **114-115** and **123** each carry power. Links **114-115** and **123** may each be a software or logical link. In other examples, links **114-115** and **123** each use various communication media, such as air, space, metal, optical fiber, or some other signal propagation path, including combinations thereof. Links **114-115** and **123** each could be direct links or might include various equipment, intermediate components, systems, and networks.

Packet link **132** uses metal, glass, optical, air, space, or some other material as the transport media. Packet link **132** could use various packet protocols or formats, such as Internet Protocol (IP), Ethernet, asynchronous transfer mode (ATM), synchronous optical networking (SONET), Wireless Fidelity (WiFi), wireless telephony, or some other communication format, including combinations, improvements, or variations thereof.

Links **131-133** may each include many different signals sharing the same link—as represented by the associated lines in FIG. 1—comprising channels, forward links, reverse links, user communications, communication sessions, frequencies, carriers, timeslots, transportation ports, logical transportation links, network sockets, packets, or communication directions. Links **131-133** could each be direct links or may include intermediate networks, systems, or devices.

DVR **110** and video encoder **120** could also each include a processing system which retrieves and executes software from a computer-readable medium. In further examples, the associated processing systems each comprise specialized circuitry, and any software or computer-readable medium could be included in the specialized circuitry to operate the processing systems. The associated computer-readable medium could include a disk, tape, integrated circuit, server,

or some other memory device, and also may be distributed among multiple memory devices. The associated software may include an operating system, logs, utilities, drivers, networking software, video processing software, and other software typically loaded onto a computer system. The associated software could contain an application program, firmware, or some other form of computer-readable processing instructions. When executed by the associated processing system, the software directs the processing system to operate as described herein.

FIGS. 1-4 and the previous descriptions depict specific embodiments to teach those skilled in the art how to make and use the best mode. For the purpose of teaching inventive principles, some conventional aspects have been simplified or omitted. Those skilled in the art will appreciate variations from these embodiments that fall within the scope of the invention. Those skilled in the art will also appreciate that the features described above can be combined in various ways to form multiple embodiments. As a result, the invention is not limited to the specific embodiments described above, but only by the claims and their equivalents.

What is claimed is:

1. A method of operating a video system, the method comprising:

outputting, by a first group of analog cameras, analog video;

outputting, by other groups of cameras, video, wherein each of the other groups is located remote from the first group;

receiving and encrypting, by a first camera interface of a digital video recorder, the analog video output by the first group of analog cameras;

receiving, by an at least one packet interface of the digital video recorder, video in a packet format from a packet link;

storing, by a storage system located within the digital video recorder, video from the first analog camera interface and from each of the packet interfaces, wherein the storage system converts from the packet format to a common video format and stores the video corresponding to the video output by the other groups of cameras;

receiving, by a second camera interface of a video encoder, the video output by the other groups of cameras;

processing, by an output interface of the video encoder, the video from the other groups of cameras into the packet format; and

transferring, by the output interface of the video encoder, the video from the other groups of cameras in the packet format to the digital video recorder over the packet link.

2. The method of claim 1, wherein receiving the video captured from other groups of cameras comprises receiving in a digital format the video captures from the other groups of cameras.

3. The method of claim 1, wherein receiving the video captured from other groups of cameras comprises receiving in an analog format the video captures from the other groups of cameras.

4. The method of claim 3, wherein the method further comprises encrypting, by the second camera interface, the analog video output by the other groups of cameras.

5. The method of claim 3, wherein the method further comprises encoding, by the second camera interface, the analog video output by the other groups of cameras.

6. The method of claim 3, wherein the method further comprises processing, by the output interface, the analog video received from the second camera interface of the video output by the other groups of cameras.

7. The method of claim 1, wherein the packet format comprises an Internet protocol (IP) packet format.

8. The method of claim 1, wherein the packet link comprises a packet link over the Internet.

9. The method of claim 1, wherein the packet link comprises a wireless packet link.

10. The method of claim 1, wherein the storing comprises storing, in a selected frame rate, the video corresponding to (1) the video from the first plurality of analog cameras and (2) the video from the packet link.

11. The method of claim 1, further comprising: retrieving, by a playback system, a selected portion of the video stored by the storage system and displaying the selected portion of the video to a user of the digital video recorder.

12. The method of claim 1, further comprising: displaying, by a playback video from one or more of a day-at-a-glance, a week-at-a-glance, and a motion-based search of the stored video.

13. A video system comprising: a first group of analog cameras outputting analog video; other groups of analog cameras outputting analog video, wherein each of the other groups is located remote from the first group of analog cameras; a digital video recorder comprising:

a first analog camera interface receiving analog video from each of the analog cameras in the first group via a different analog link,

packet interfaces, wherein each packet interface receives video in a packet format from a different packet link,

a storage system located within the digital video recorder and storing video from the first analog camera interface and from each of the packet interfaces;

a playback system receiving a selected portion of the video stored by the storage system and displaying the selected portion of the video to a user of the digital video recorder;

a graphical user interface configured to allow the user to select video stored by the storage system for playback; and video encoders, wherein each video encoder is coupled to the digital video recorder by a different packet link and wherein each video encoder comprises:

a second analog camera interface receiving analog video from each of the analog cameras in one of the other groups via a different analog link, and

an output interface processing the received analog video into a packet format and transmitting the video in packet format over a packet link connecting the output interface and one of the digital video recorder's packet interfaces, wherein the storage system converts from a packet format to a common video stores in a non-packet format and stores the video corresponding to the analog video output by the other groups of analog cameras.

14. The video system of claim 13, further comprising: a playback system displaying video from one or more of a day-at-a-glance, a week-at-a-glance, and a motion-based search of the stored video.

15. The video system of claim 13, wherein the playback system presents live video captured by the first group of

analog cameras simultaneously to the selected portion of the video stored by the storage system.

16. The video system of claim 13, wherein the playback system presents live video captured by the other groups of cameras simultaneously to the selected portion of the video 5 stored by the storage system.

17. The video system of claim 13, wherein the user interface further allows the user to select live video for playback captured by either the first group of analog cameras or by the other groups of cameras. 10

18. The video system of claim 13, wherein the user interface further allows the user to set criteria for the storage system in saving the video from the first group of analog cameras and video from the other groups of cameras.

19. The video system of claim 18, wherein the criteria 15 include different resolutions, frame rates, and image retention features.

\* \* \* \* \*