

US010546748B2

(12) **United States Patent**  
**Yu et al.**

(10) **Patent No.:** **US 10,546,748 B2**  
(45) **Date of Patent:** **Jan. 28, 2020**

(54) **TIN OXIDE FILMS IN SEMICONDUCTOR DEVICE MANUFACTURING**

(71) Applicant: **Lam Research Corporation**, Fremont, CA (US)

(72) Inventors: **Jengyi Yu**, San Ramon, CA (US); **Samantha Tan**, Fremont, CA (US); **Yu Jiang**, San Jose, CA (US); **Hui-Jung Wu**, Pleasanton, CA (US); **Richard Wise**, Los Gatos, CA (US); **Yang Pan**, Los Altos, CA (US); **Nader Shamma**, Cupertino, CA (US); **Boris Voloskiy**, San Jose, CA (US)

(73) Assignee: **Lam Research Corporation**, Fremont, CA (US)

(\*) Notice: Subject to any disclaimer, the term of this patent is extended or adjusted under 35 U.S.C. 154(b) by 0 days.

(21) Appl. No.: **15/894,635**

(22) Filed: **Feb. 12, 2018**

(65) **Prior Publication Data**  
US 2018/0240667 A1 Aug. 23, 2018

**Related U.S. Application Data**

(60) Provisional application No. 62/479,709, filed on Mar. 31, 2017, provisional application No. 62/460,573, filed on Feb. 17, 2017.

(51) **Int. Cl.**  
**H01L 21/311** (2006.01)  
**H01L 21/033** (2006.01)  
(Continued)

(52) **U.S. Cl.**  
CPC ..... **H01L 21/0332** (2013.01); **H01L 21/0262** (2013.01); **H01L 21/0274** (2013.01);  
(Continued)

(58) **Field of Classification Search**  
CPC ..... H04W 40/22; H04W 76/30; H04W 88/04; H01J 2237/186; H01J 2237/3321;  
(Continued)

(56) **References Cited**  
U.S. PATENT DOCUMENTS

4,708,766 A 11/1987 Hyncek  
4,778,562 A 10/1988 Chang  
(Continued)

FOREIGN PATENT DOCUMENTS

KR 10-2017-0141673 A 12/2017

OTHER PUBLICATIONS

Office Action, dated Feb. 9, 2017, issued in U.S. Appl. No. 15/195,348.  
(Continued)

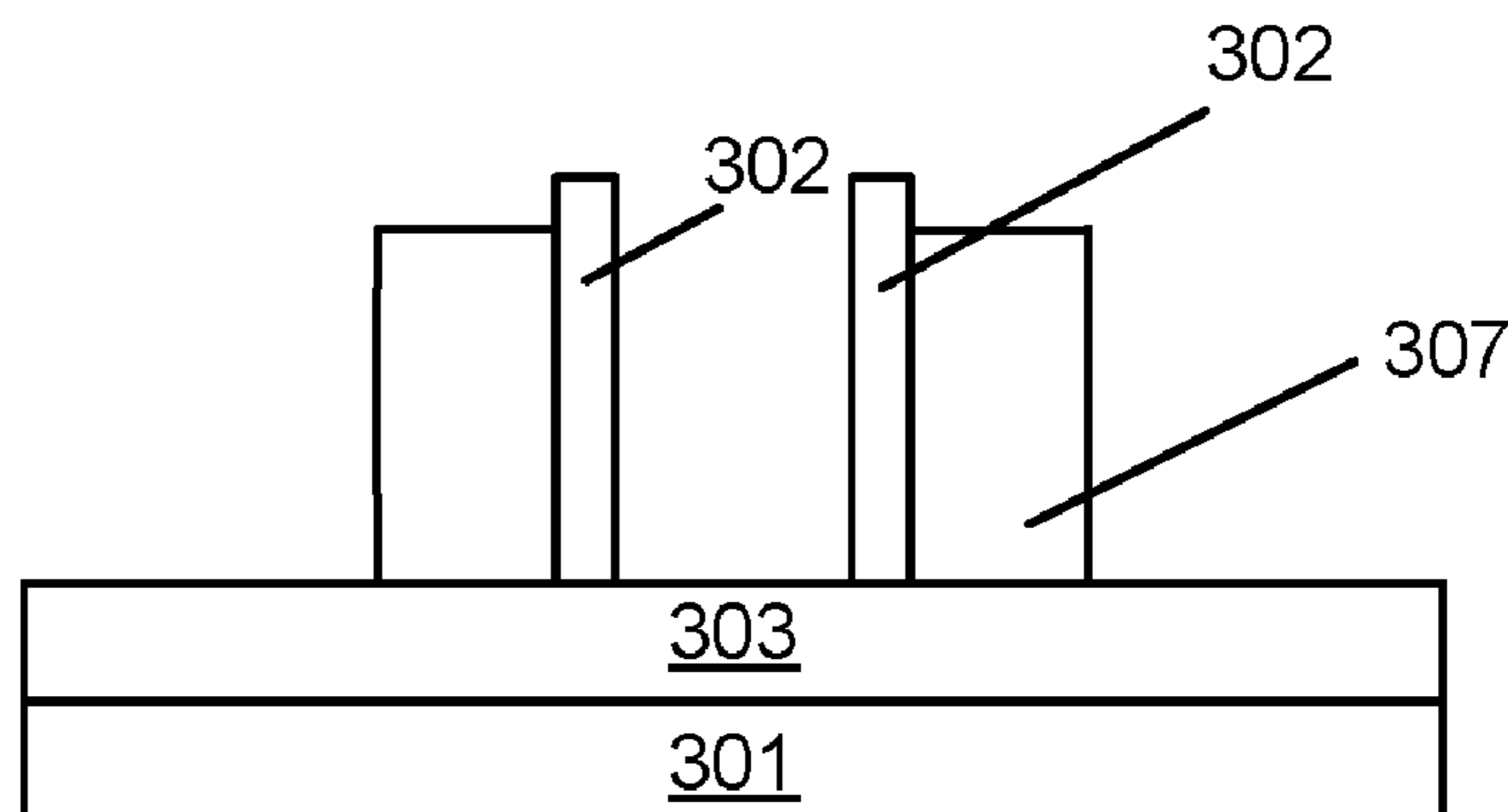
*Primary Examiner* — Lan Vinh

(74) *Attorney, Agent, or Firm* — Weaver Austin Villeneuve & Sampson LLP

(57) **ABSTRACT**

Tin oxide films are used as spacers and hardmasks in semiconductor device manufacturing. In one method, tin oxide layer is formed conformally over sidewalls and horizontal surfaces of protruding features on a substrate. A passivation layer is then formed over tin oxide on the sidewalls, and tin oxide is then removed from the horizontal surfaces of the protruding features without being removed at the sidewalls of the protruding features. The material of the protruding features is then removed while leaving the tin oxide that resided at the sidewalls of the protruding features, thereby forming tin oxide spacers. Hydrogen-based and chlorine-based dry etch chemistries are used to selectively etch tin oxide in a presence of a variety of materials. In another method a patterned tin oxide hardmask layer is formed on a substrate by forming a patterned layer over an unpatterned tin oxide and transferring the pattern to the tin oxide.

**20 Claims, 20 Drawing Sheets**



- (51) **Int. Cl.**  
**H01L 21/027** (2006.01)  
**H01L 21/67** (2006.01)  
**H01L 21/02** (2006.01)  
**H01L 21/3065** (2006.01)  
**H01L 21/3213** (2006.01)  
**H01L 21/465** (2006.01)  
**H01L 21/467** (2006.01)  
**H01J 37/32** (2006.01)  
**H01L 21/683** (2006.01)  
**H01L 21/68** (2006.01)

- (52) **U.S. Cl.**  
 CPC .. **H01L 21/02175** (2013.01); **H01L 21/02565** (2013.01); **H01L 21/0337** (2013.01); **H01L 21/3065** (2013.01); **H01L 21/31116** (2013.01); **H01L 21/31122** (2013.01); **H01L 21/31138** (2013.01); **H01L 21/31144** (2013.01); **H01L 21/32136** (2013.01); **H01L 21/32137** (2013.01); **H01L 21/32139** (2013.01); **H01L 21/465** (2013.01); **H01L 21/467** (2013.01); **H01L 21/67069** (2013.01); **H01L 21/67167** (2013.01); **H01L 21/67207** (2013.01); **H01J 37/3211** (2013.01); **H01J 37/32651** (2013.01); **H01J 2237/186** (2013.01); **H01J 2237/334** (2013.01); **H01J 2237/3321** (2013.01); **H01L 21/0228** (2013.01); **H01L 21/02205** (2013.01); **H01L 21/02274** (2013.01); **H01L 21/68** (2013.01); **H01L 21/6833** (2013.01)

- (58) **Field of Classification Search**  
 CPC ..... H01J 2237/334; H01J 37/3211; H01J 37/32651; H01L 21/02175; H01L 21/02205; H01L 21/02274; H01L 21/02565; H01L 21/0274; H01L 21/0332; H01L 21/0337; H01L 21/3065; H01L 21/31144; H01L 21/467; H01L 21/67069  
 USPC ..... 216/67, 72, 75; 438/706, 710, 714, 722, 438/723, 758  
 See application file for complete search history.

(56) **References Cited**

U.S. PATENT DOCUMENTS

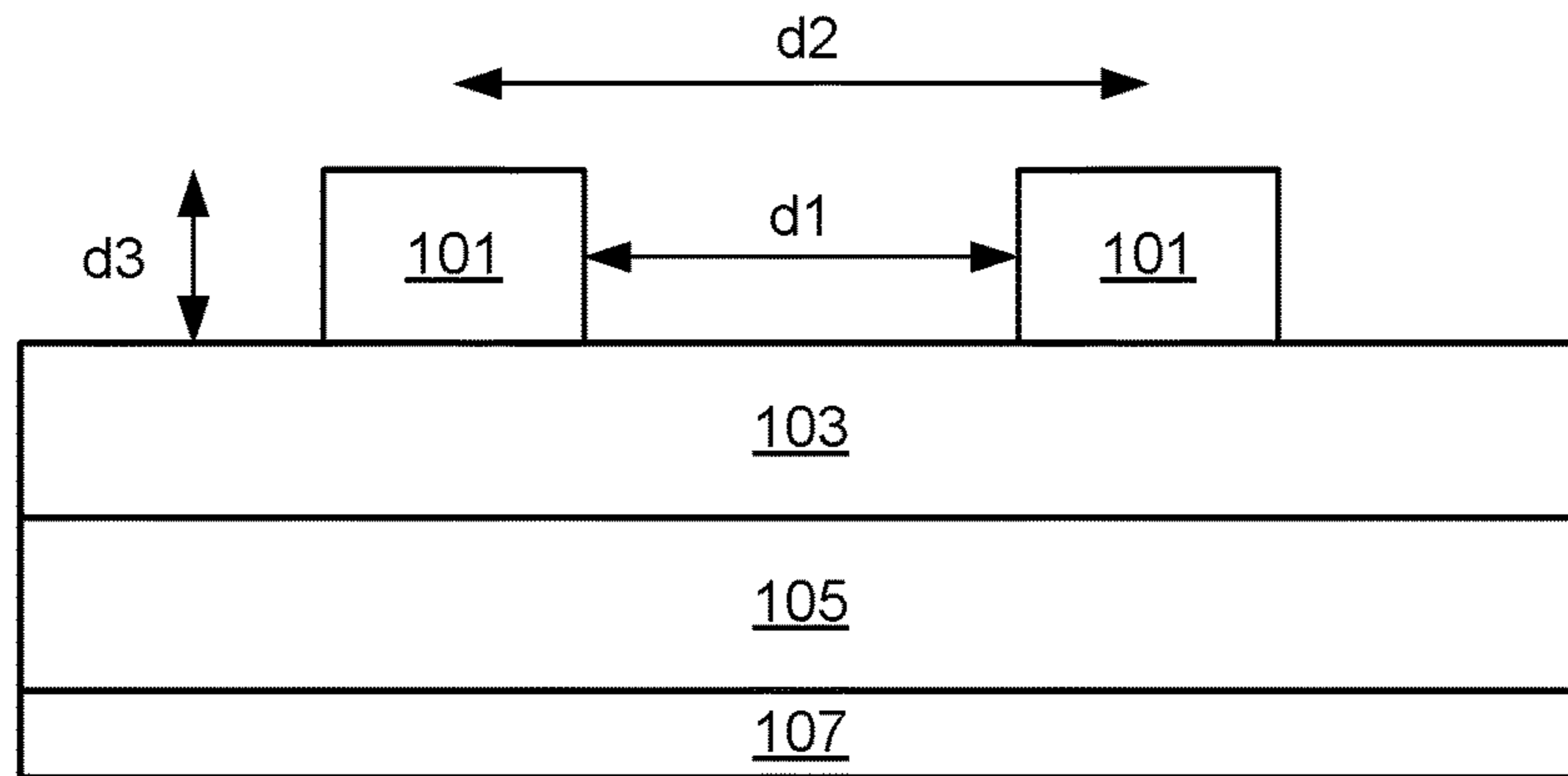
5,286,337 A	2/1994	Tsou	
5,318,664 A	6/1994	Saia et al.	
5,607,602 A	3/1997	Su et al.	
5,667,631 A	9/1997	Holland et al.	
6,036,876 A *	3/2000	Chen .....	H01L 21/32136 216/67
6,368,978 B1	4/2002	Kumar et al.	
6,416,822 B1	7/2002	Chiang et al.	
6,428,859 B1	8/2002	Chiang et al.	
7,459,732 B2	12/2008	Fleischer et al.	
8,163,094 B1	4/2012	Greer et al.	
8,435,608 B1	5/2013	Subramonium et al.	
8,747,964 B2	6/2014	Park et al.	
8,969,110 B2 *	3/2015	Choi .....	H01L 51/56 438/26
9,437,443 B2	9/2016	Brink et al.	
9,824,893 B1	11/2017	Smith et al.	
2006/0073706 A1	4/2006	Li et al.	
2006/0148118 A1	7/2006	Hsiung et al.	
2006/0270209 A1	11/2006	Mitsui et al.	
2010/0120247 A1	5/2010	Park	
2011/0198627 A1	8/2011	Maindron et al.	

2013/0161625 A1 *	6/2013	Ku .....	H01L 27/1288 257/59
2013/0309871 A1 *	11/2013	DeVilliers .....	H01L 21/0273 438/703
2014/0308812 A1 *	10/2014	Arghavani .....	H01L 21/7688 438/675
2015/0243661 A1 *	8/2015	Matsumoto .....	H01L 21/823814 257/369
2015/0247238 A1	9/2015	Pasquale et al.	
2015/0287612 A1	10/2015	Luere et al.	
2015/0318181 A1 *	11/2015	Cantone .....	H01L 21/823431 438/702
2016/0203982 A1 *	7/2016	Lin .....	H01L 21/3081 438/424
2016/0314985 A1	10/2016	Yang et al.	
2016/0336178 A1	11/2016	Swaminathan et al.	
2018/0012759 A1	1/2018	Smith et al.	
2018/0233398 A1	8/2018	van Cleemput et al.	

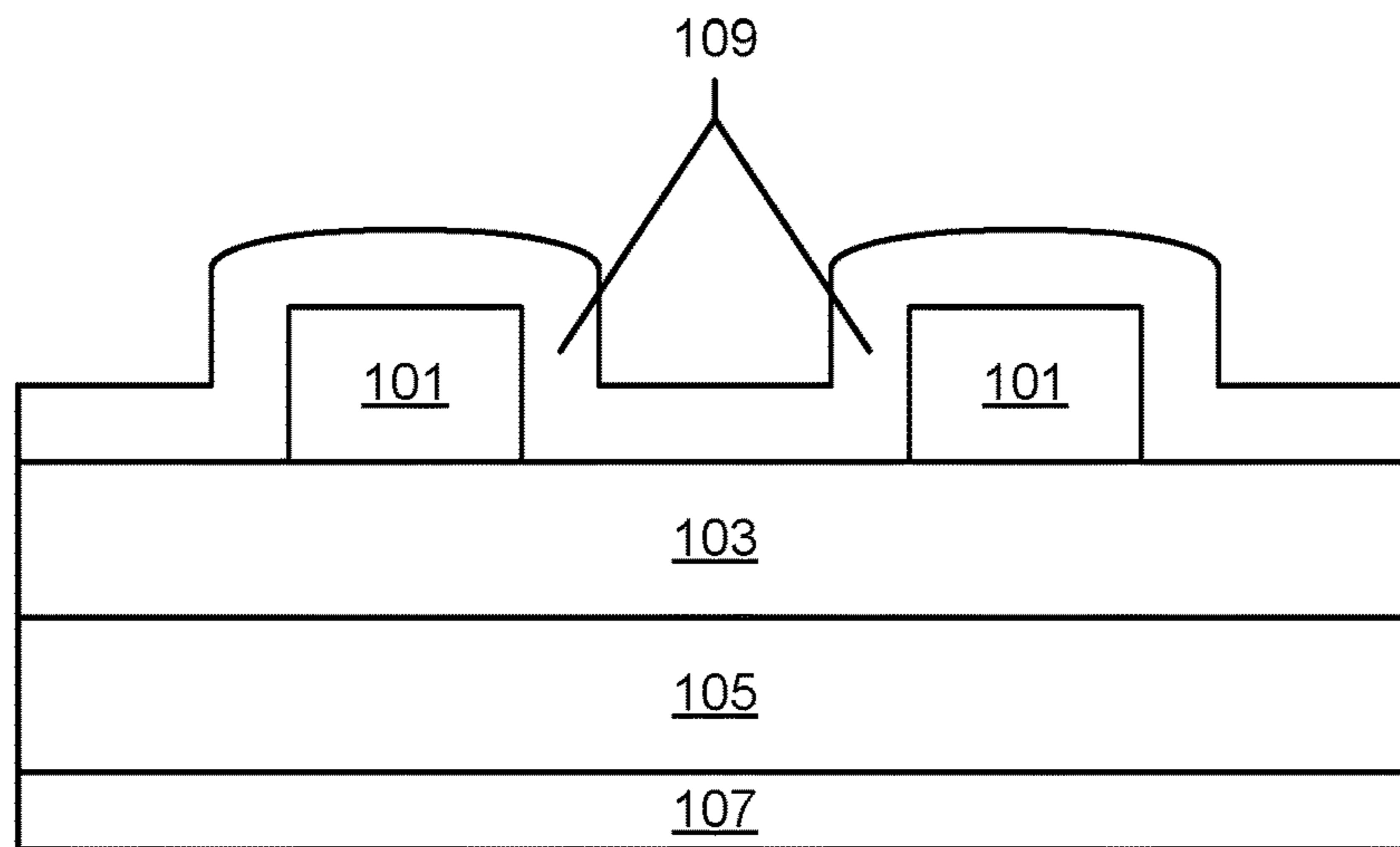
OTHER PUBLICATIONS

Notice of Allowance, dated Jun. 26, 2017, issued in U.S. Appl. No. 15/195,348.  
 Choi, W.-S., (Dec. 25, 2009) "The Fabrication of Tin Oxide Films by Atomic Layer Deposition using Tetrakis(Ethylmethylamino) Tin Precursor," *Transactions on Electrical and Electronic Materials*, 10(6):200-202.  
 Du, X. et al., (Jul./Aug. 2005) "In situ examination of tin oxide atomic layer deposition using quartz crystal microbalance and Fourier transform infrared techniques," *J. Vac. Sci. Technol. A*, 23(4):581-588.  
 Elam, J.W., et al, (2008) "Atomic Layer Deposition of Indium Tin Oxide Thin Films Using Nonhalogenated Precursors," *J. Phys. Chem. C*, 112(6):1938-1945.  
 Elam, J.W., et al, (Mar./Apr. 2008) "Atomic layer deposition of tin oxide films using tetrakis(dimethylamino) tin," *J. Vac. Sci. Technol. A*, 26(2):244-252.  
 Heo, J., et al., (2010) "Low Temperature Atomic Layer Deposition of Tin Oxide," *Chemistry of Materials*, 22(17):4964-4973.  
 Heo, J., et al., (2012) "Atomic layer deposition of tin oxide with nitric oxide as an oxidant gas," *J. Mater. Chem.*, 22:4599-4602.  
 Kwon, K.H., et al., (Mar./Apr. 2010) "Etch mechanism of In<sub>2</sub>O<sub>3</sub> and SnO<sub>2</sub> thin films in HBr-based inductively coupled plasmas," *J. Vac. Sci. Technol. A* 28(2):226-231.  
 Li, X., et al., (2012) "Tin Oxide with Controlled Morphology and Crystallinity by Atomic Layer Deposition onto Graphene Nanosheets for Enhanced Lithium Storage," *Advanced Function Materials*, 22:1647-1654.  
 Mohri et al., (Oct. 1990) "Plasma Etching of ITO Thin Films Using a CH<sub>4</sub>/H<sub>2</sub> Gas Mixture," *Japanese Journal of Applied Physics*, 29(10):L1932-L1935.  
 Mullings, M.N., et al., (Nov./Dec. 2013) "Tin oxide atomic layer deposition from tetrakis(dimethylamino)tin and water," *J. Vac. Sci. Technol. A*, 31(6):061503-1-061503-8.  
 Wolf, S. and Tauber, R.N. (1986) "Silicon Processing for the VLSI Era," *Process Technology*, vol. 1, Lattice Press, pp. 545-547.  
 Wu, B.-R., et al., (2014) "Texture-Etched SnO<sub>2</sub> Glasses Applied to Silicon Thin-Film Solar Cells," *Journal of Nanomaterials*, vol. 2014, Article ID 907610, 9 pages.  
 U.S. Appl. No. 15/893,458, filed Feb. 9, 2018, Cleemput et al.  
 International Search Report and Written Opinion dated Jun. 27, 2018 issued in Application No. PCT/US18/18019.  
 International Search Report and Written Opinion dated May 17, 2019 issued in Application No. PCT/US2019/015559.  
 U.S. Office Action, dated Sep. 13, 2019, issued in U.S. Appl. No. 15/893,458.  
 International Preliminary Report on Patentability dated Aug. 29, 2019 issued in Application No. PCT/US2018/018019.

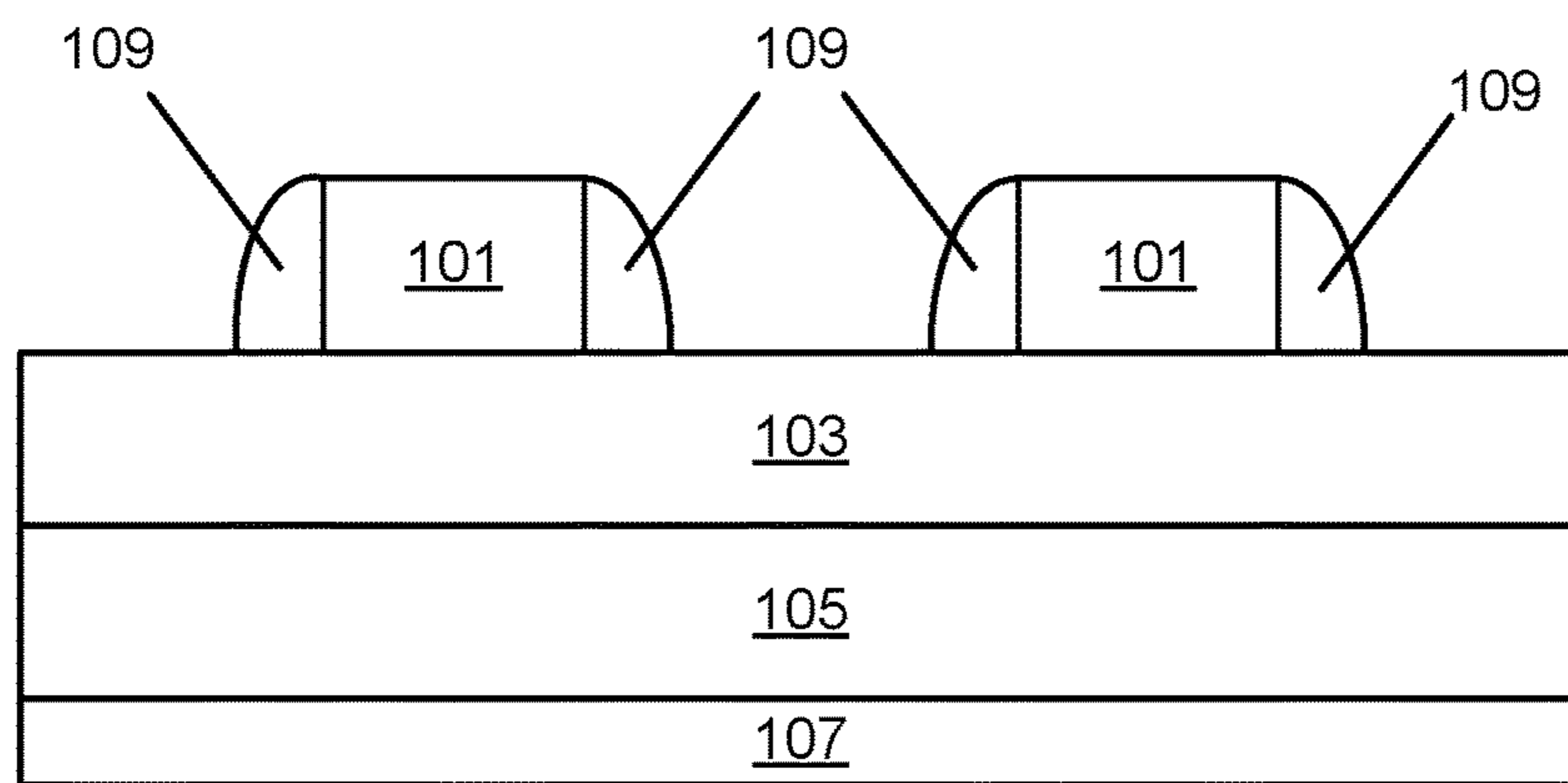
\* cited by examiner



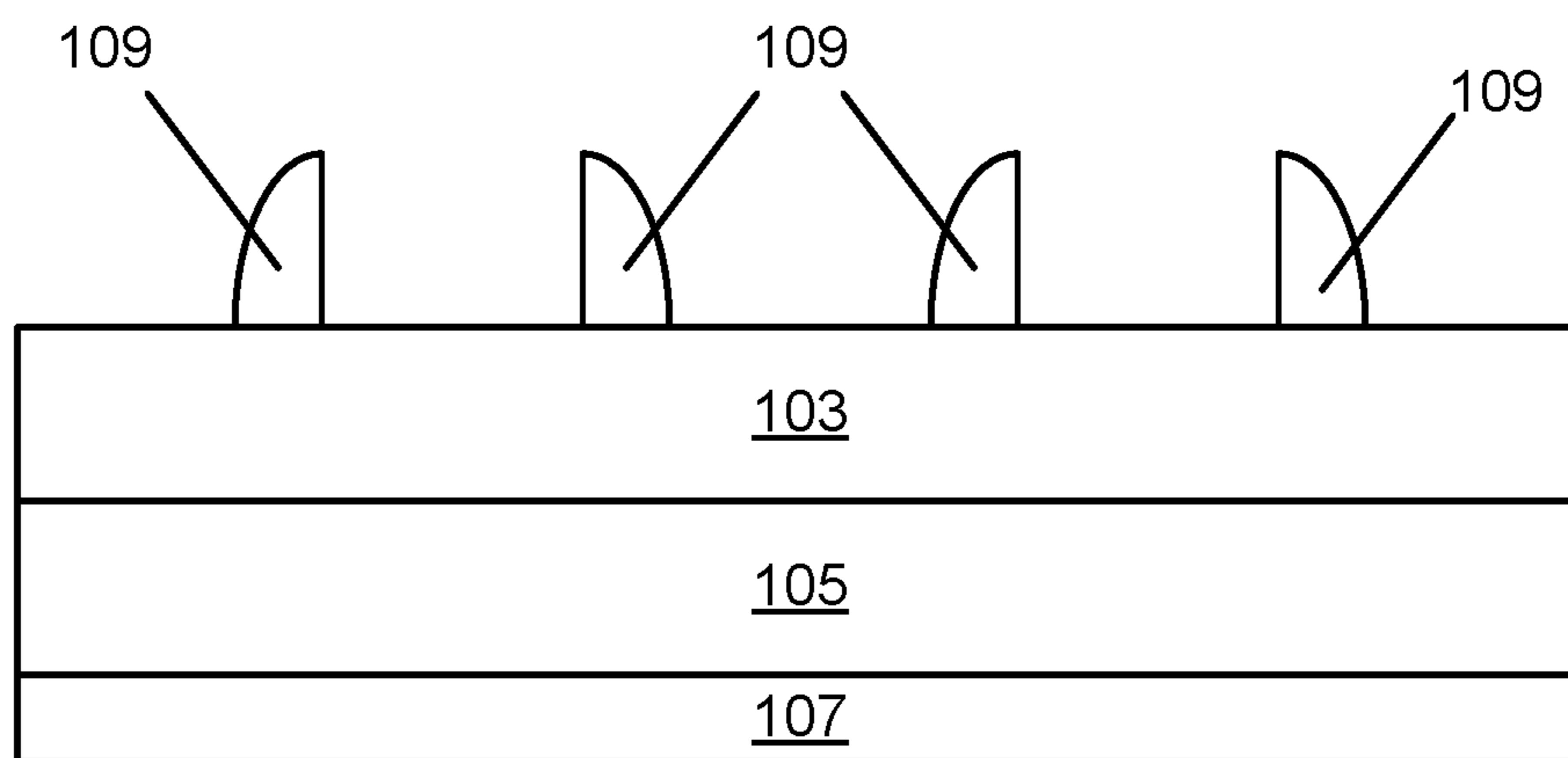
**FIG. 1A**



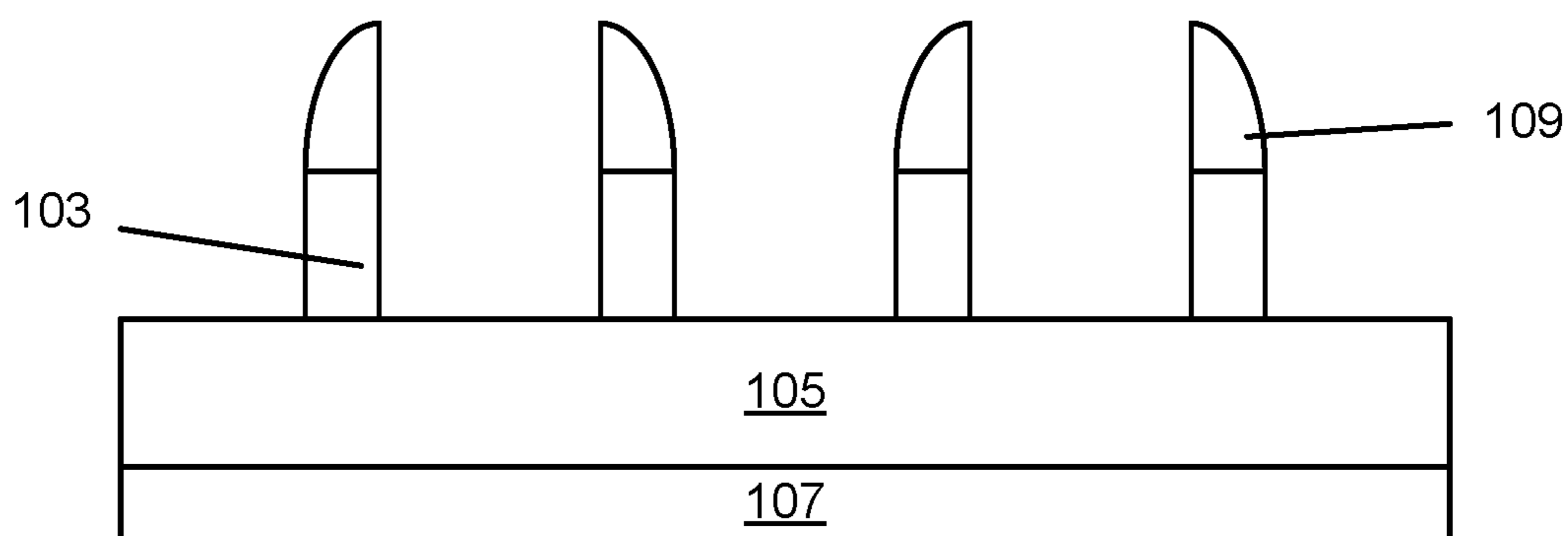
**FIG. 1B**



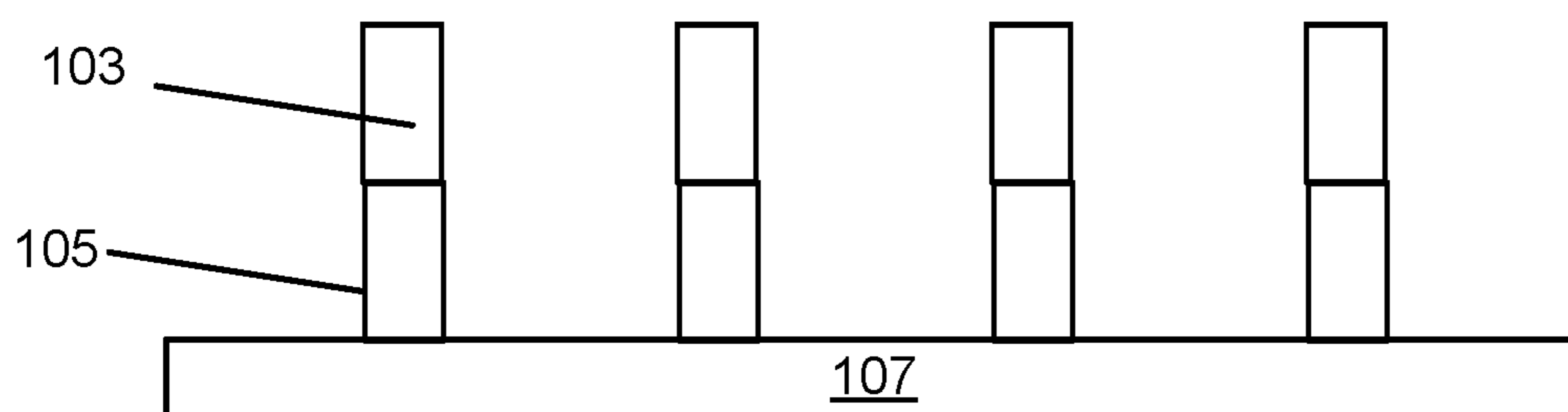
**FIG. 1C**



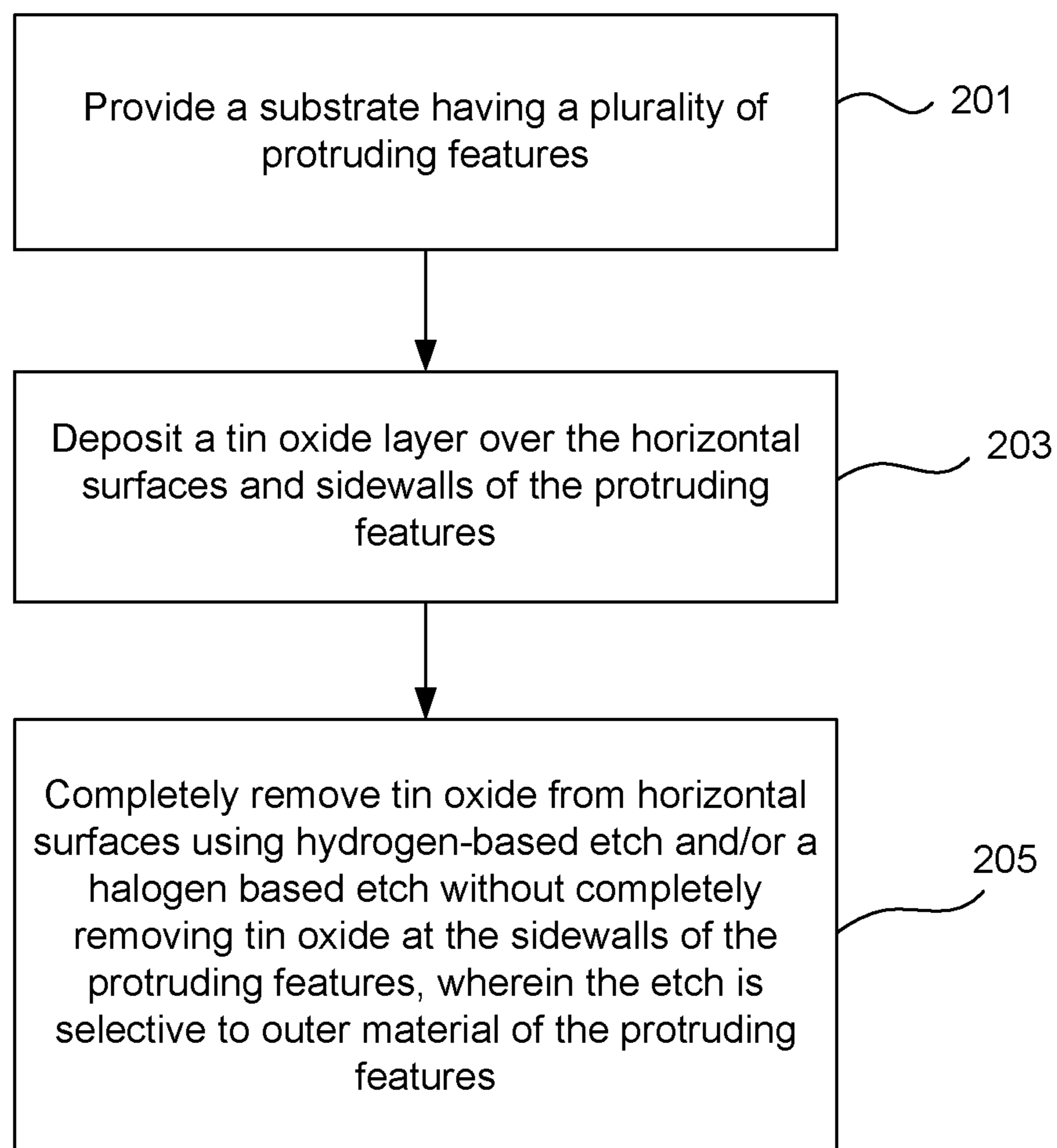
**FIG. 1D**

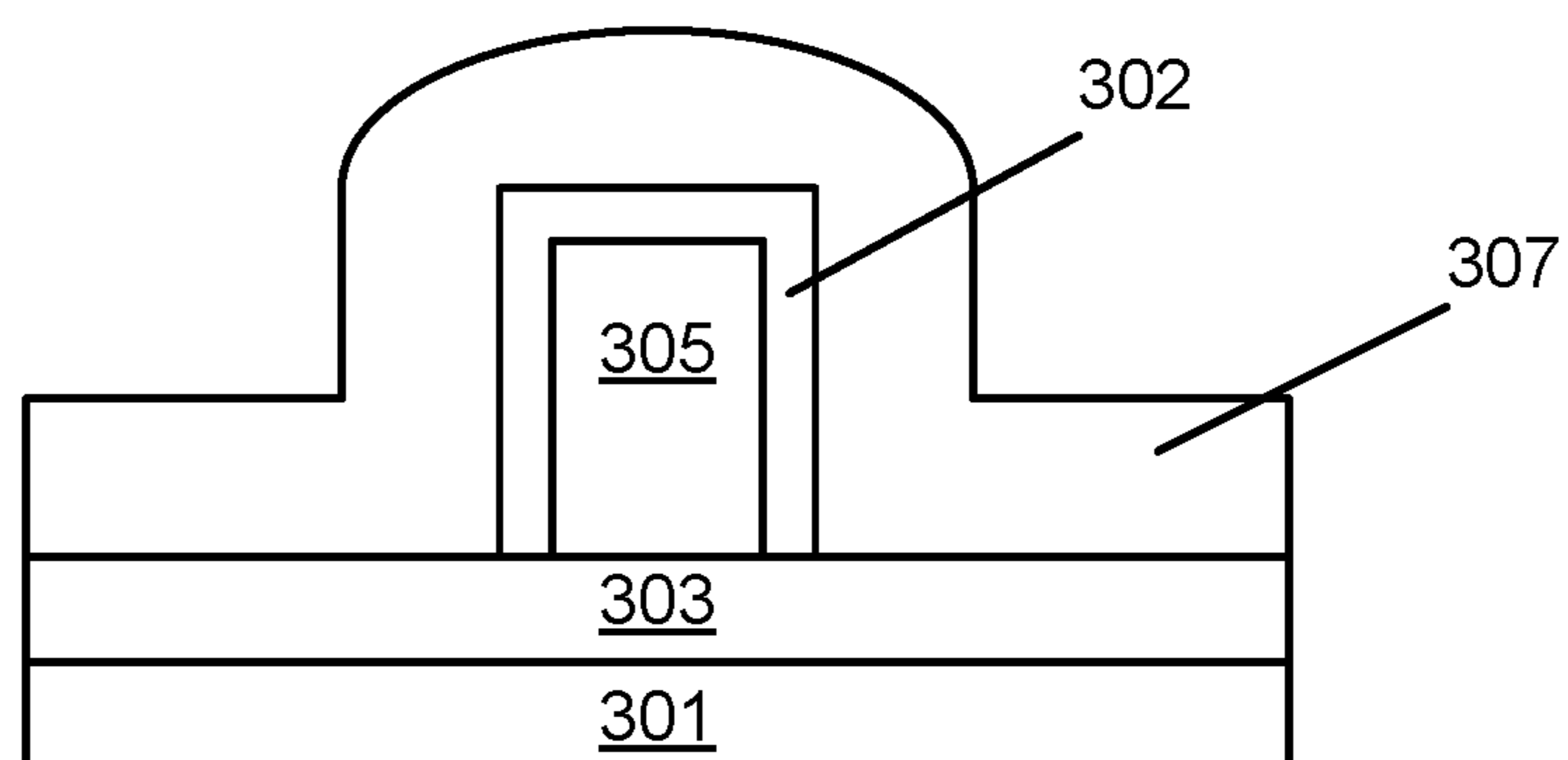


**FIG. 1E**

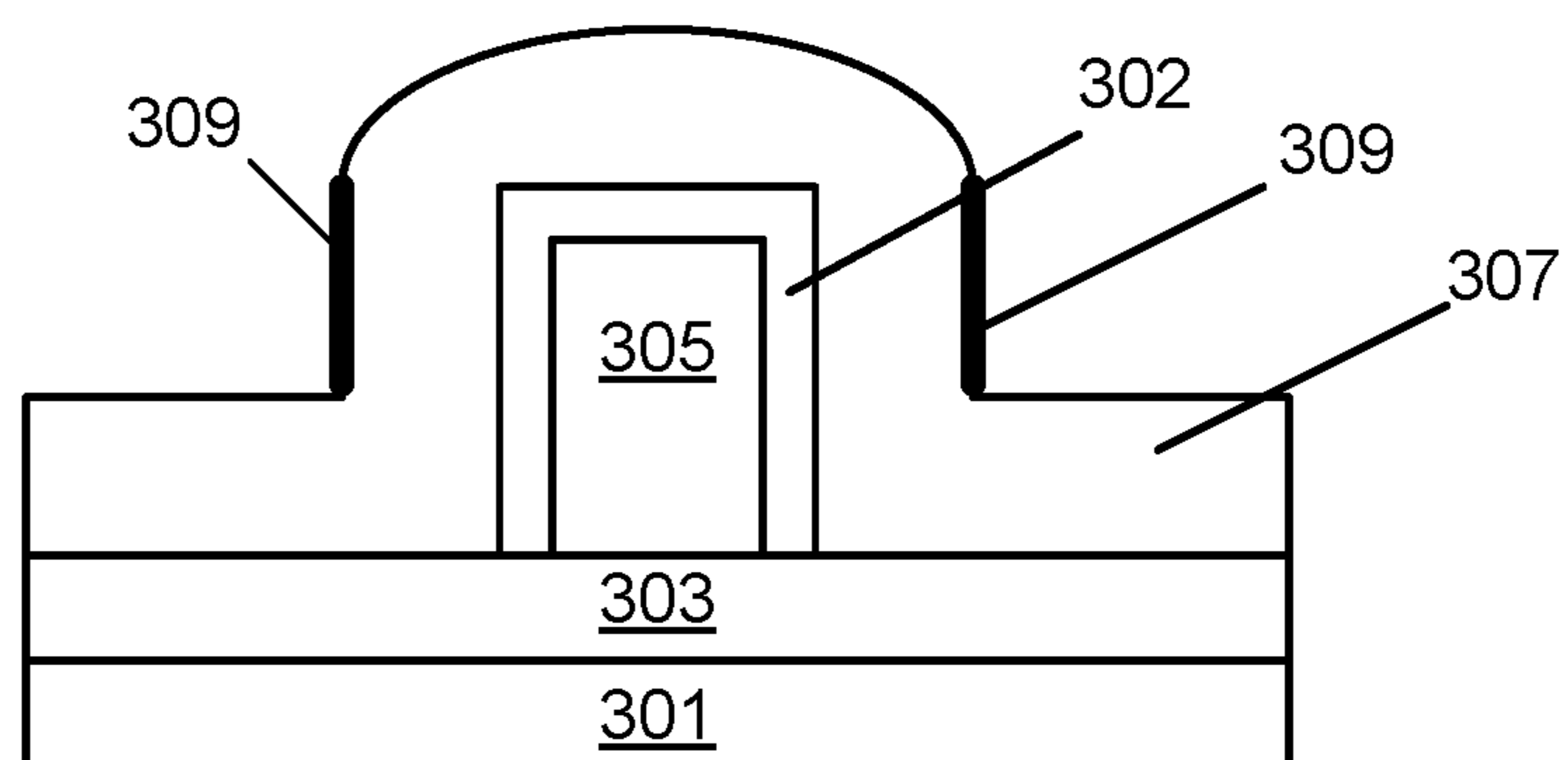


**FIG. 1F**

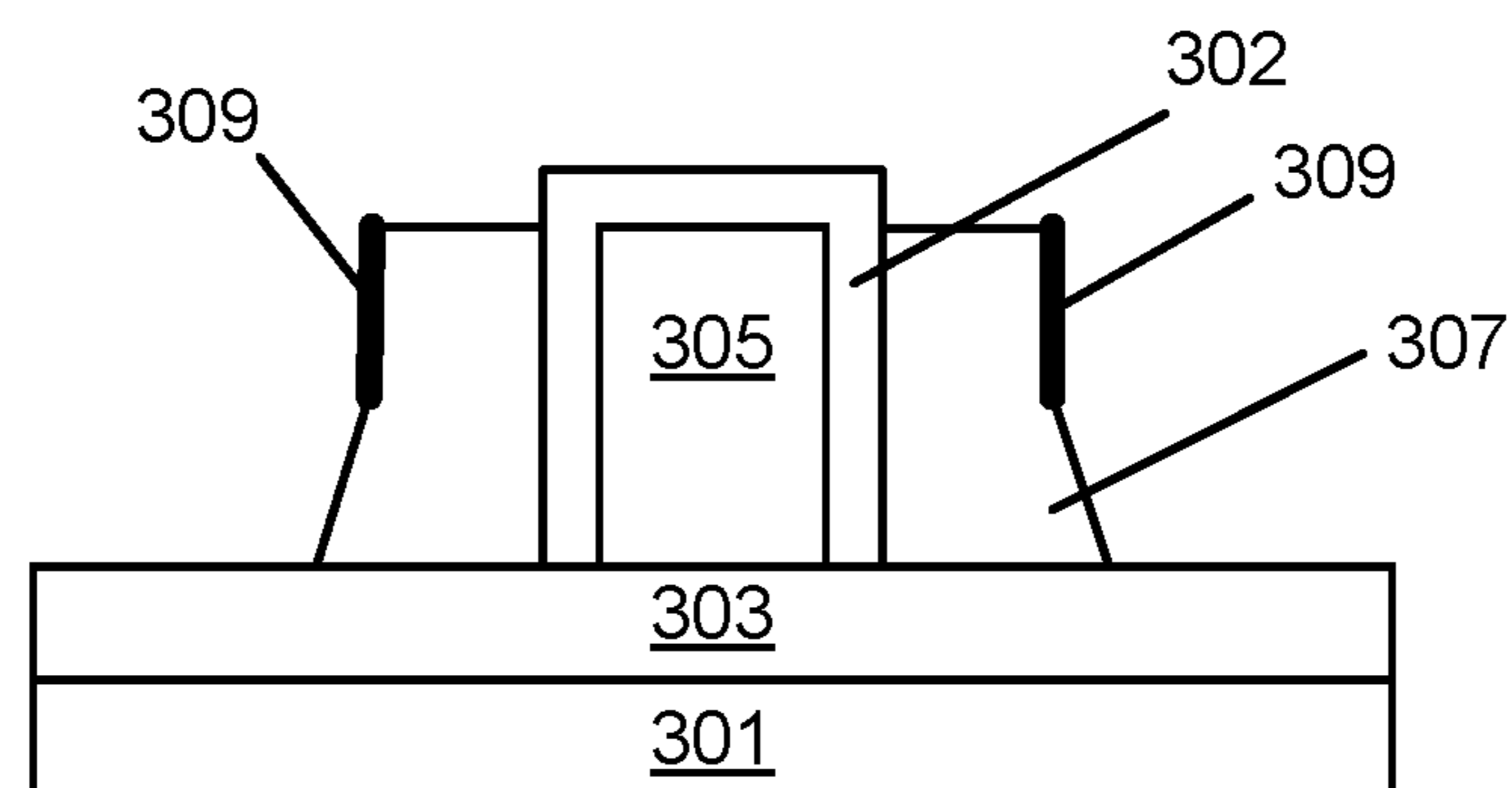
*Fig. 2*



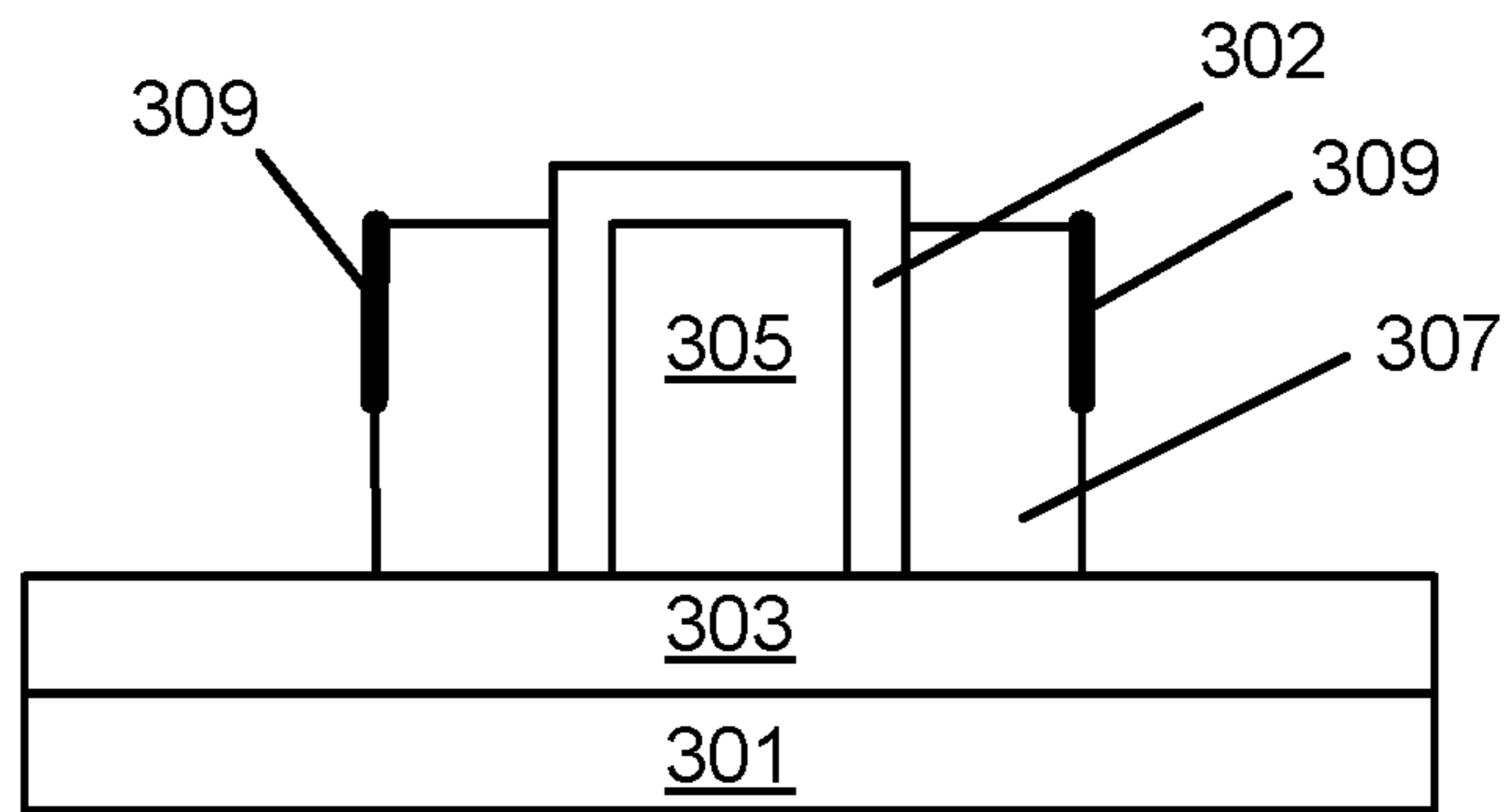
**FIG. 3A**



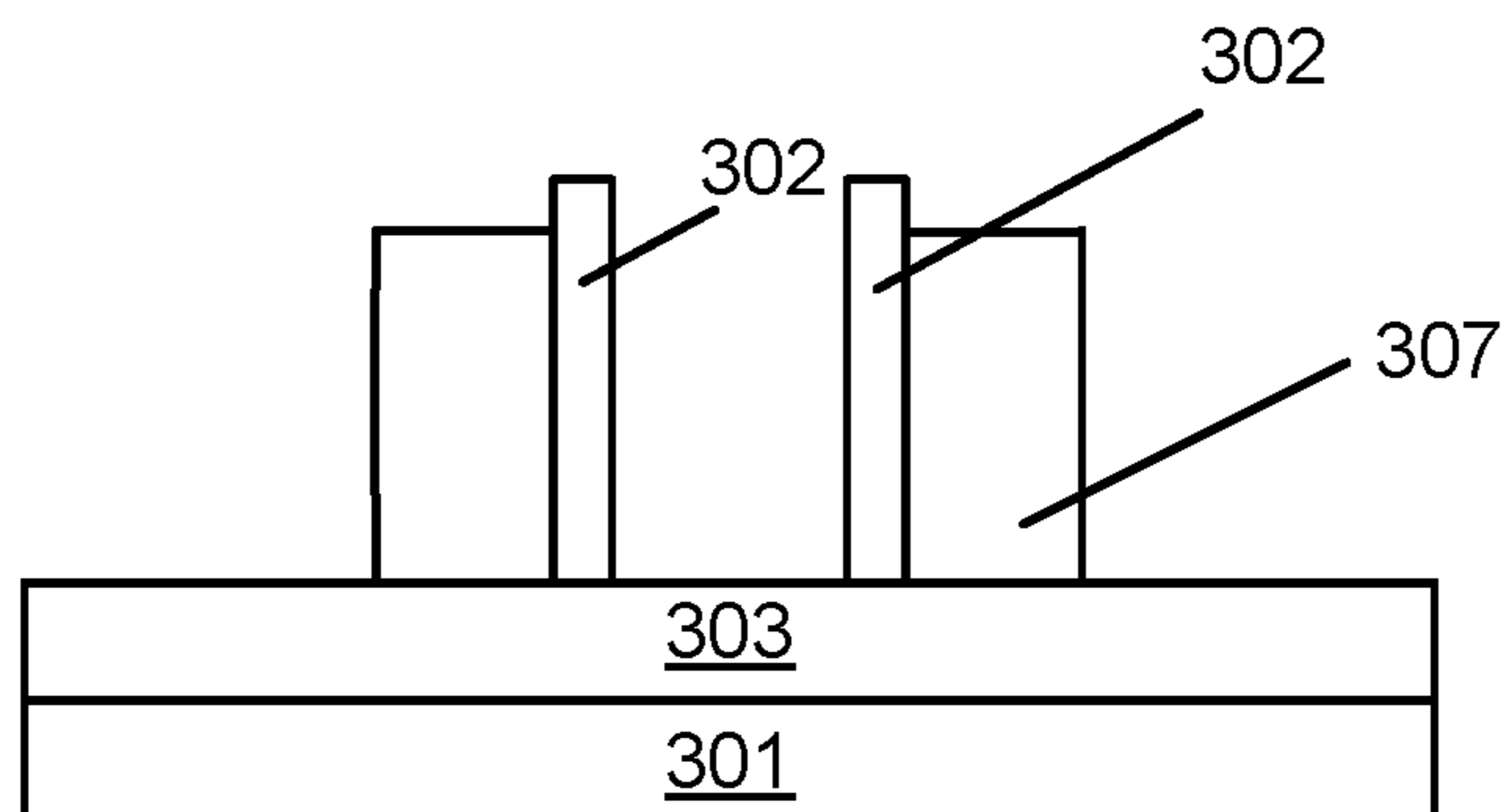
**FIG. 3B**



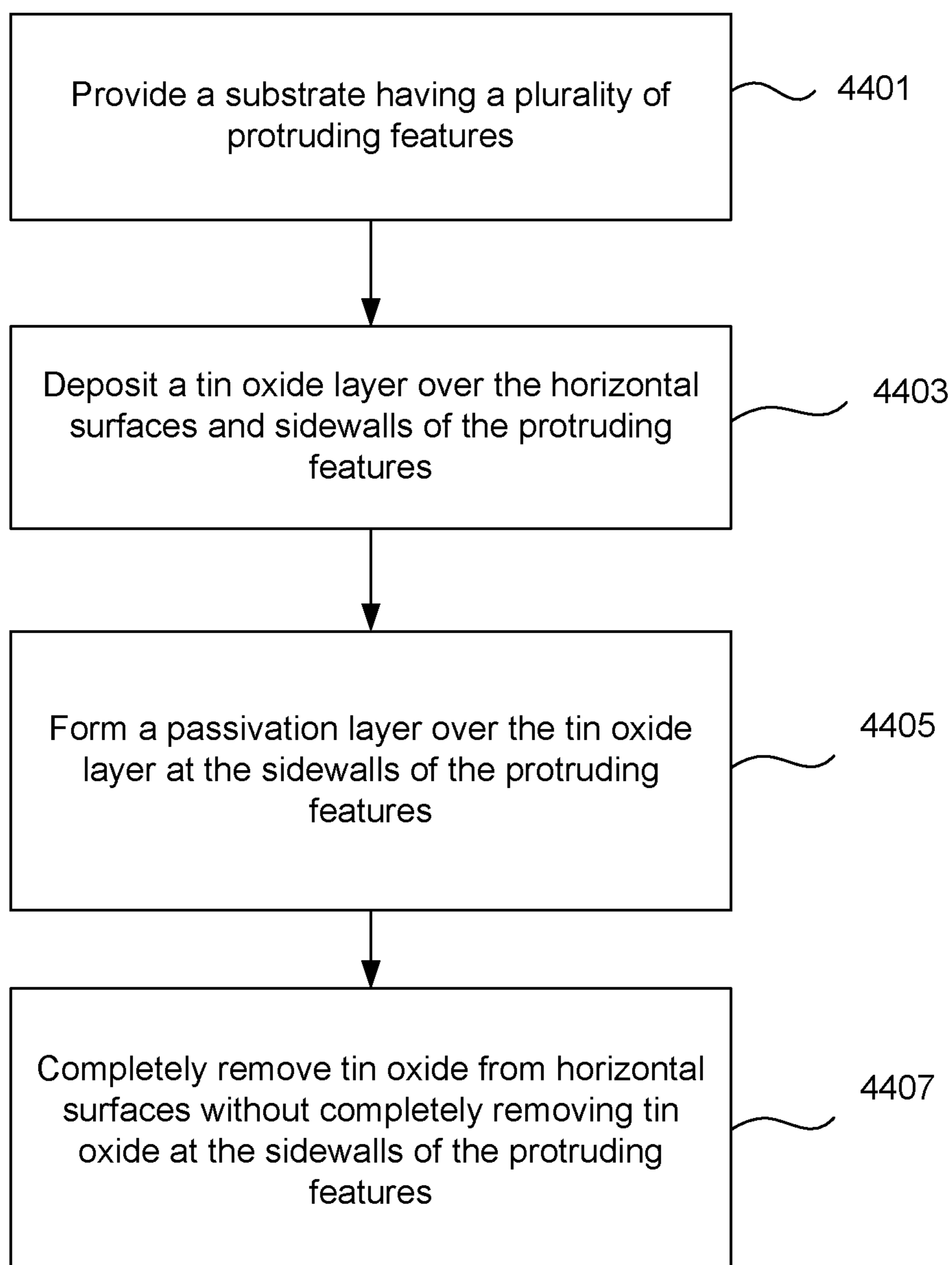
**FIG. 3C**



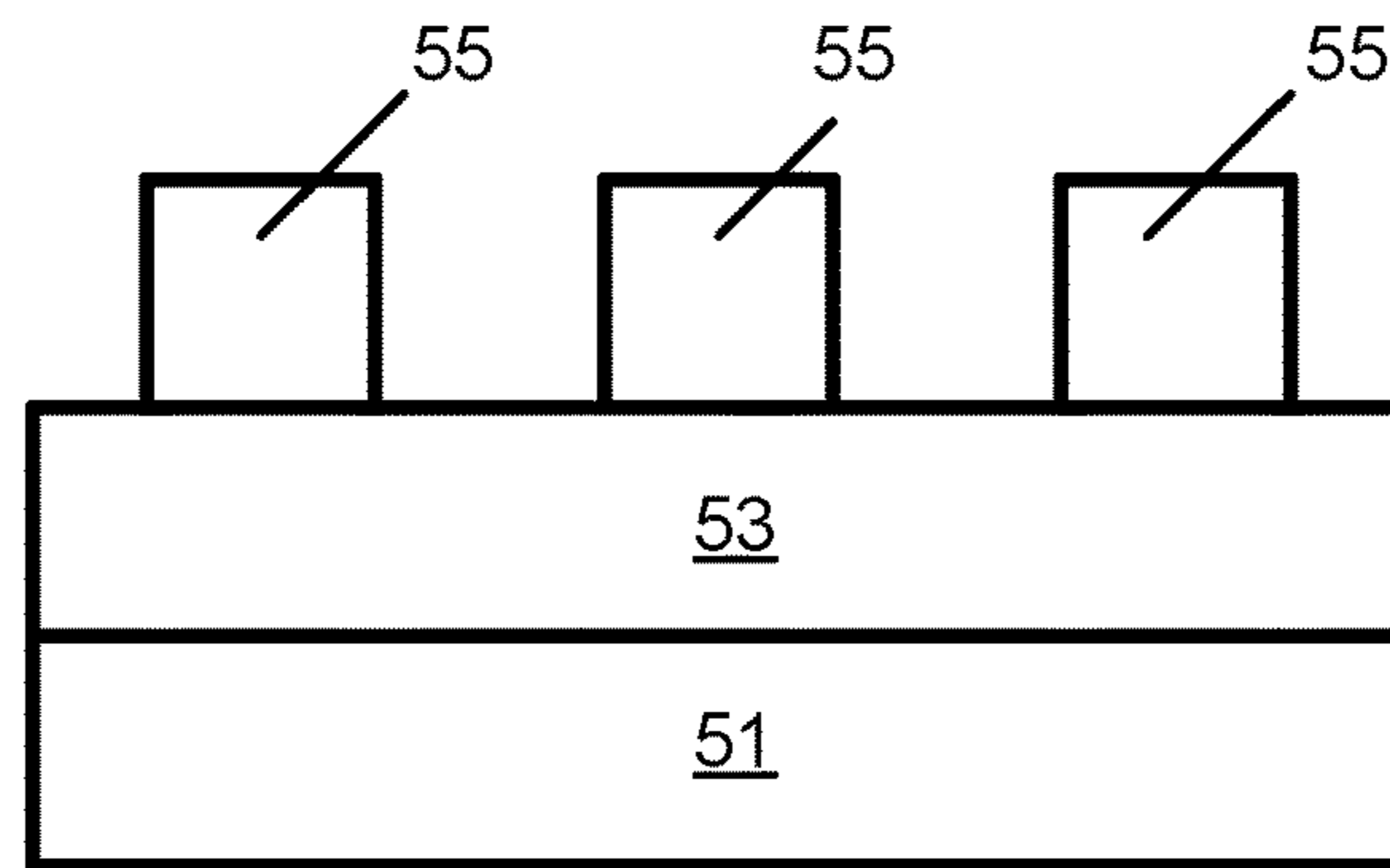
**FIG. 3D**



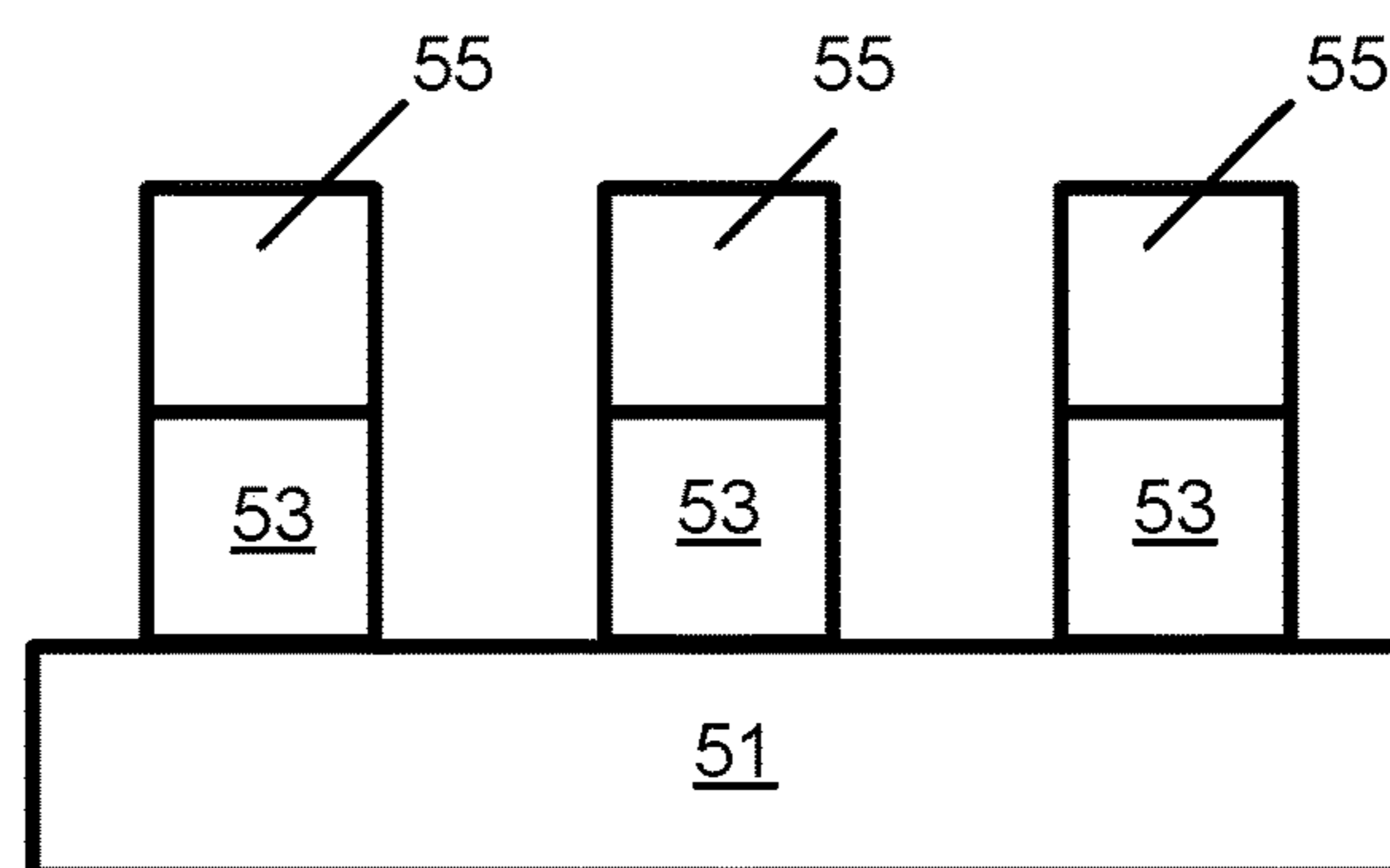
**FIG. 3E**

*Fig. 4*

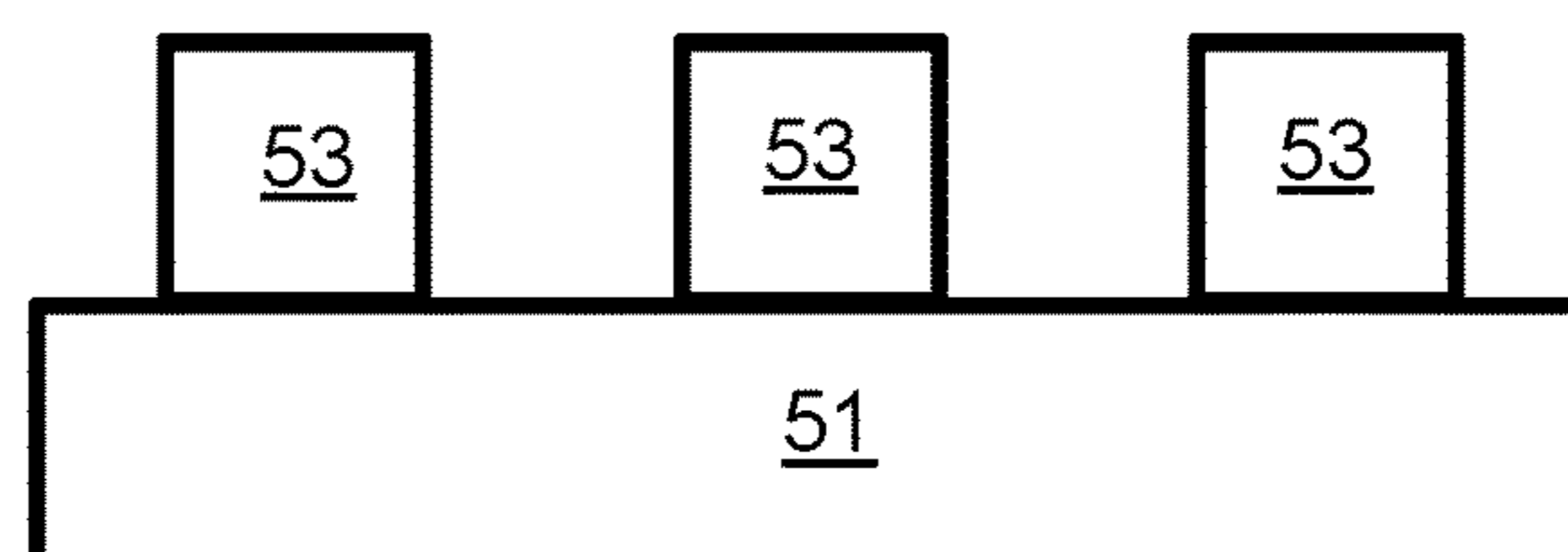




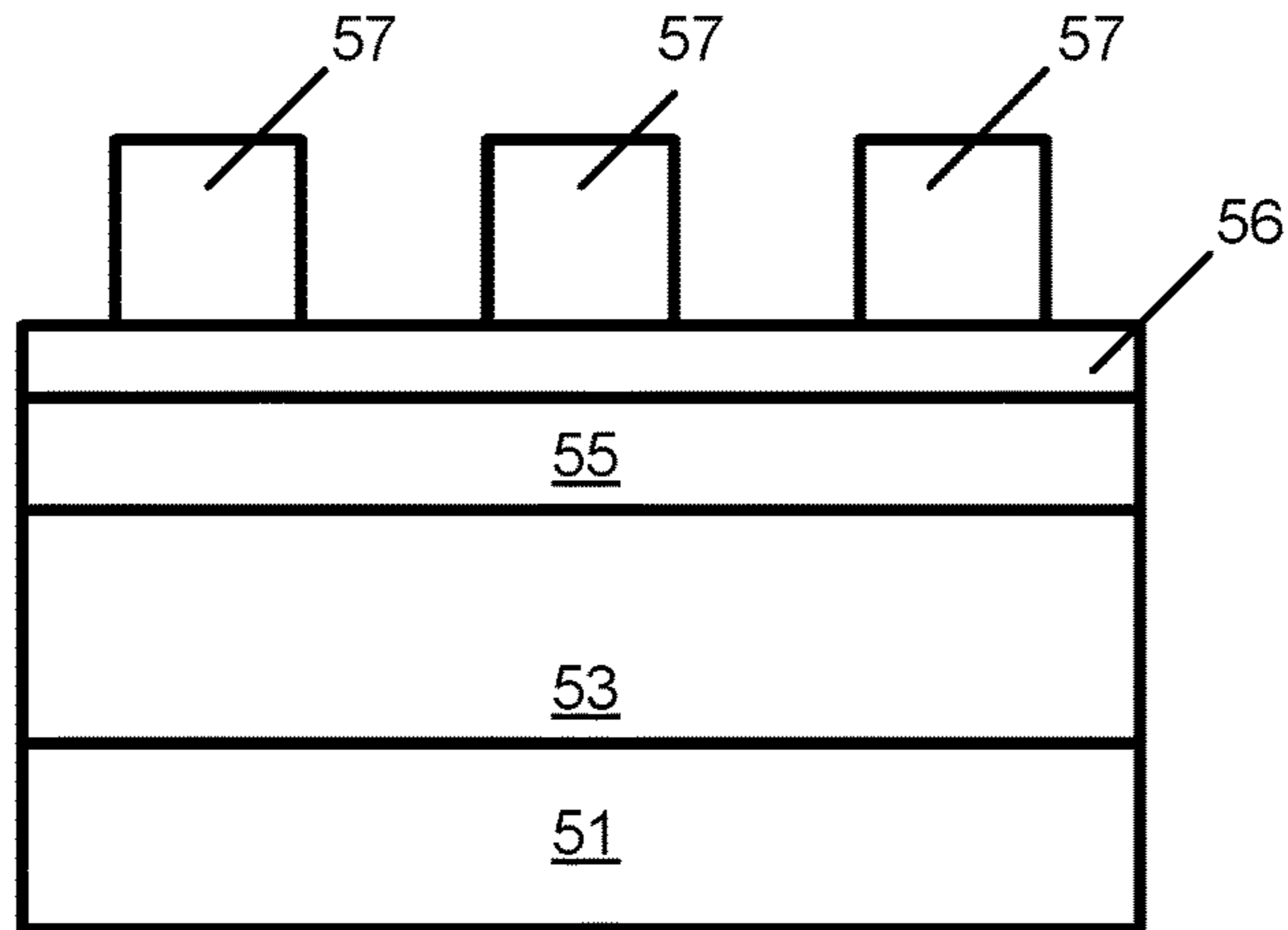
*Fig. 5A*



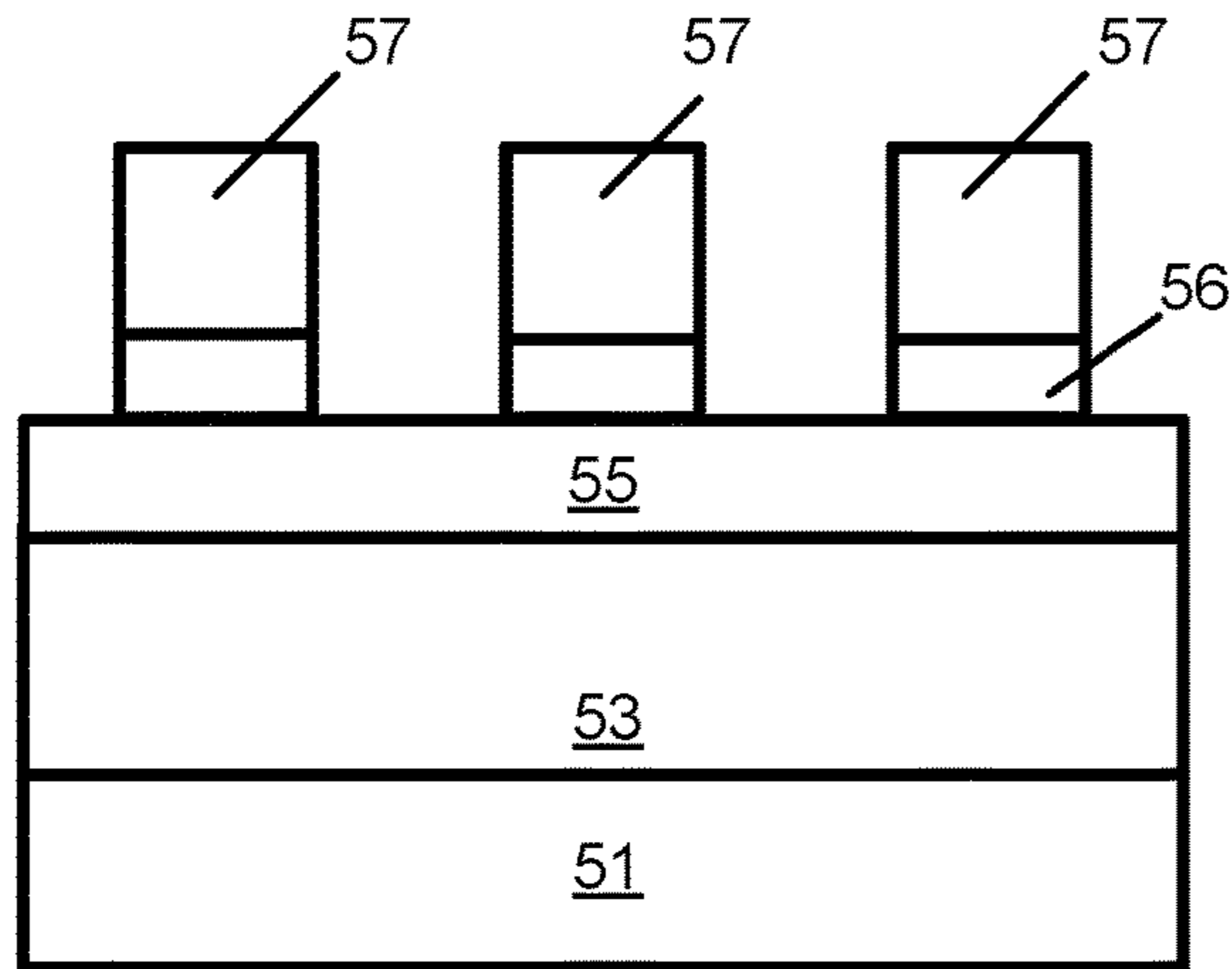
*Fig. 5B*



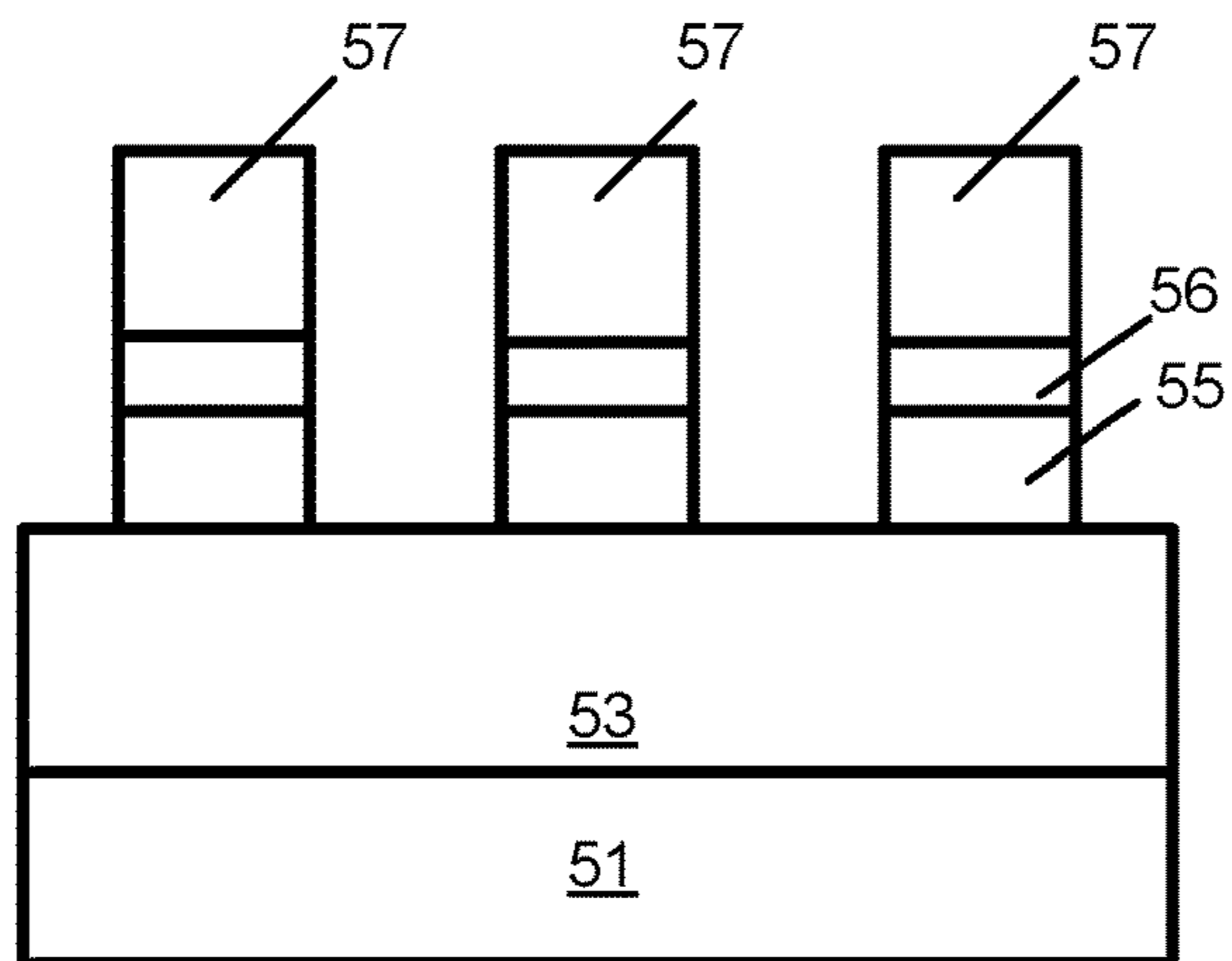
*Fig. 5C*



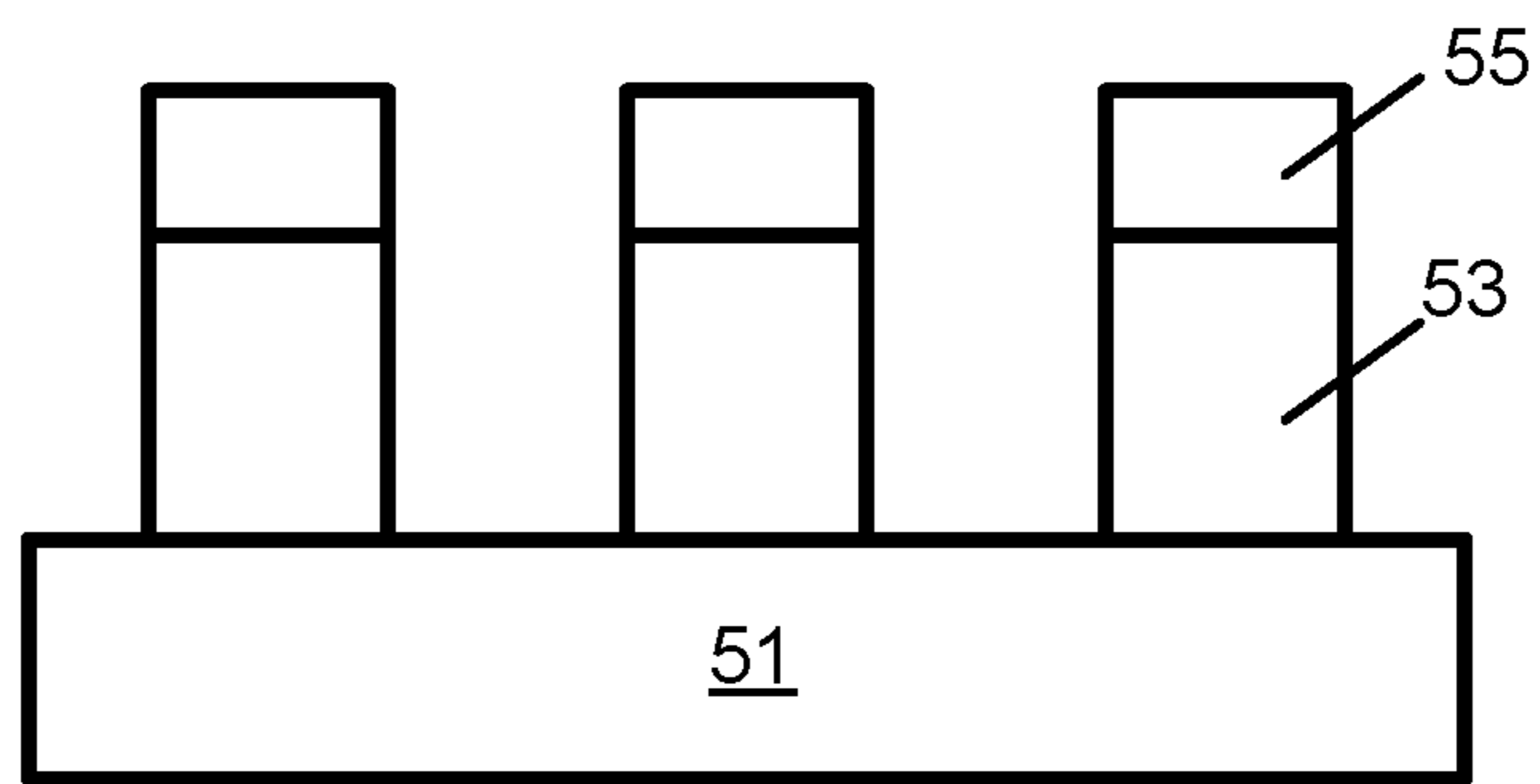
*Fig. 5D*



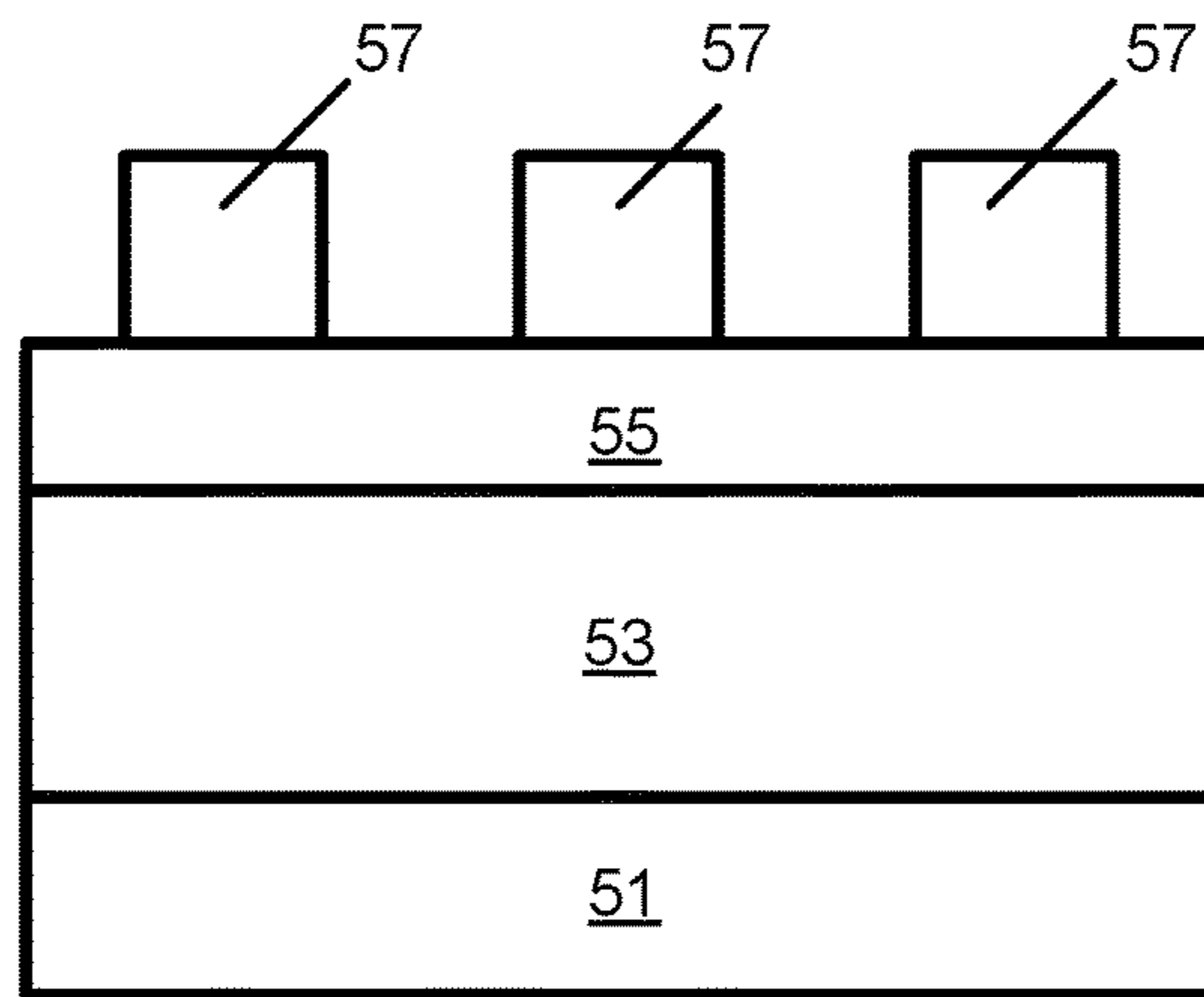
*Fig. 5E*



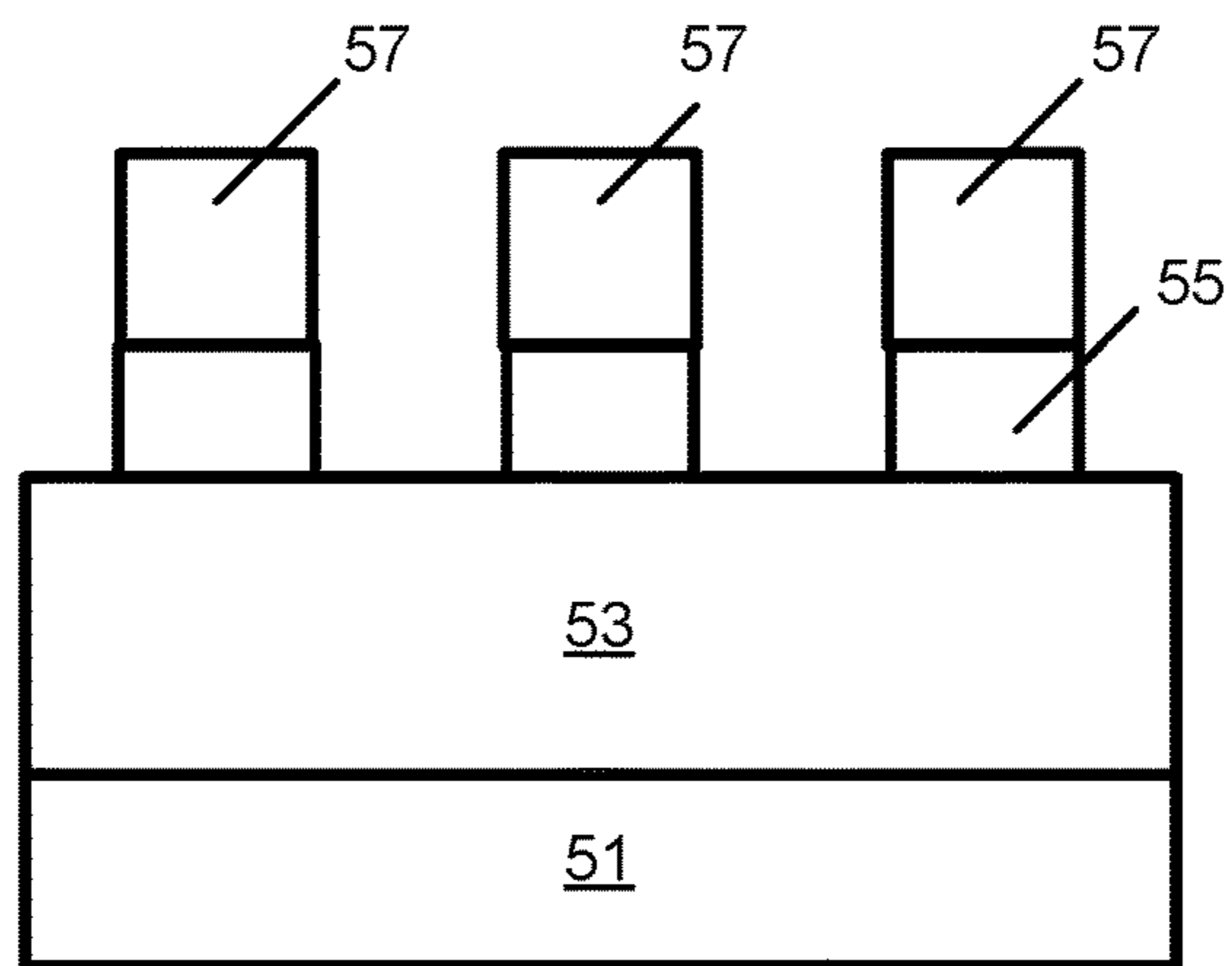
*Fig. 5F*



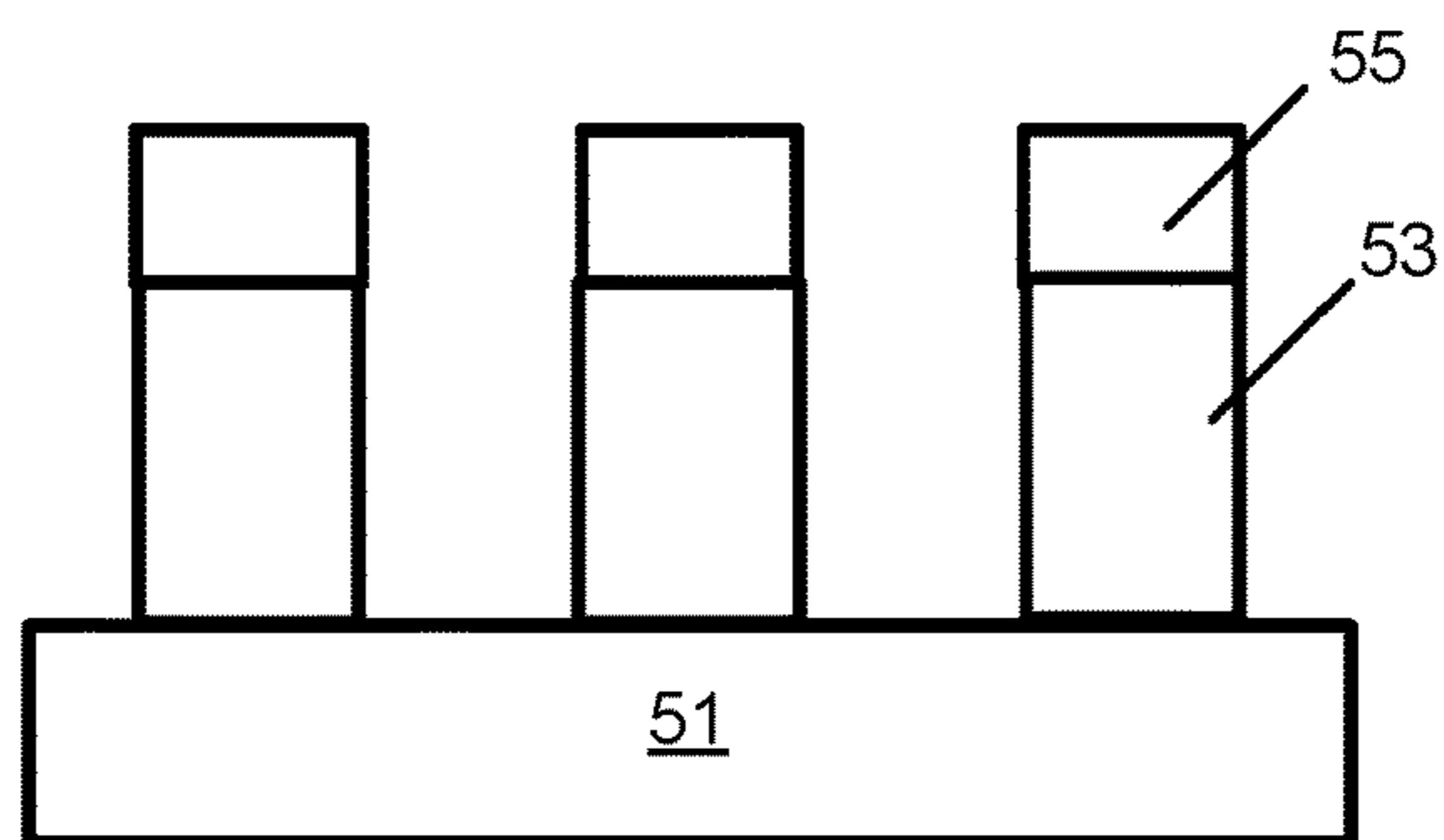
*Fig. 5G*



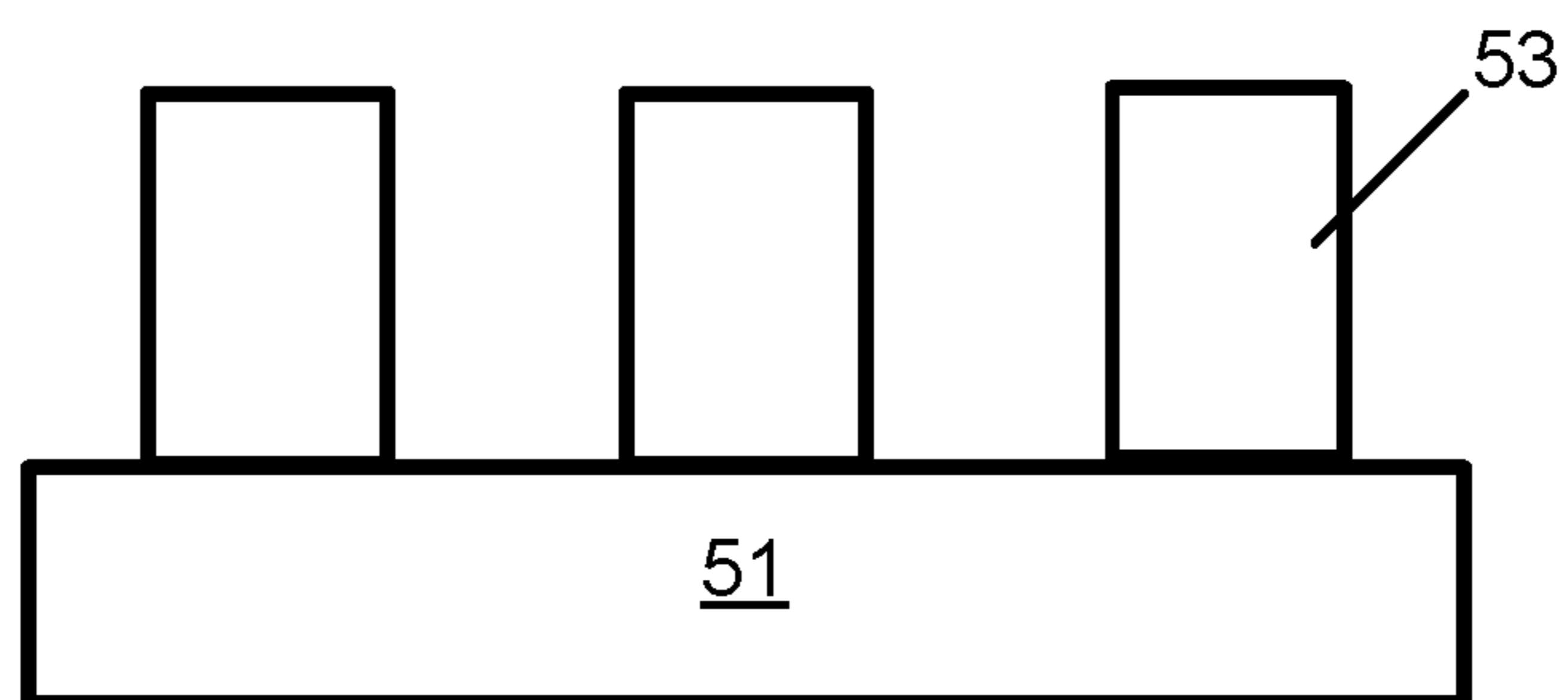
*Fig. 5H*



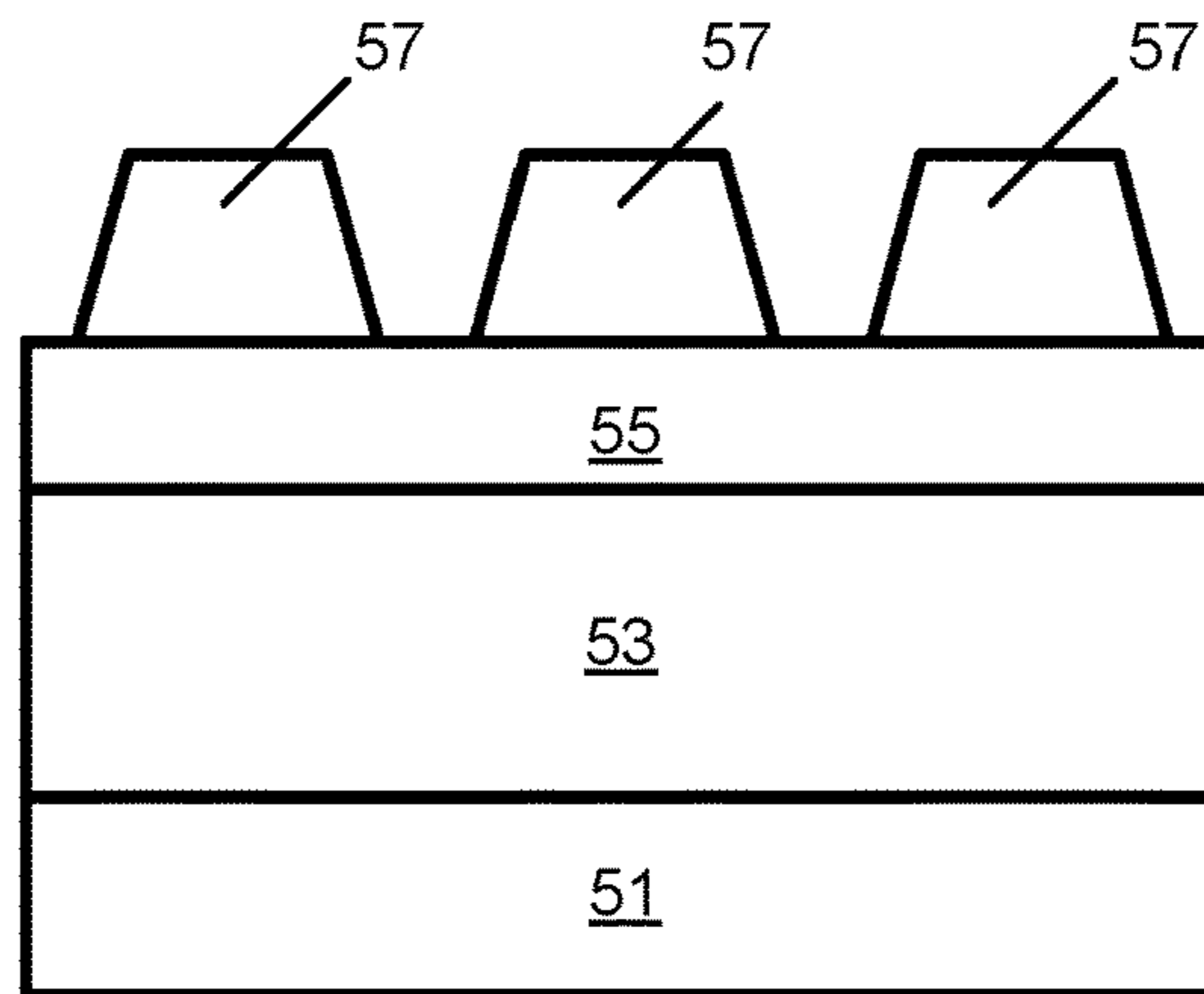
*Fig. 5I*



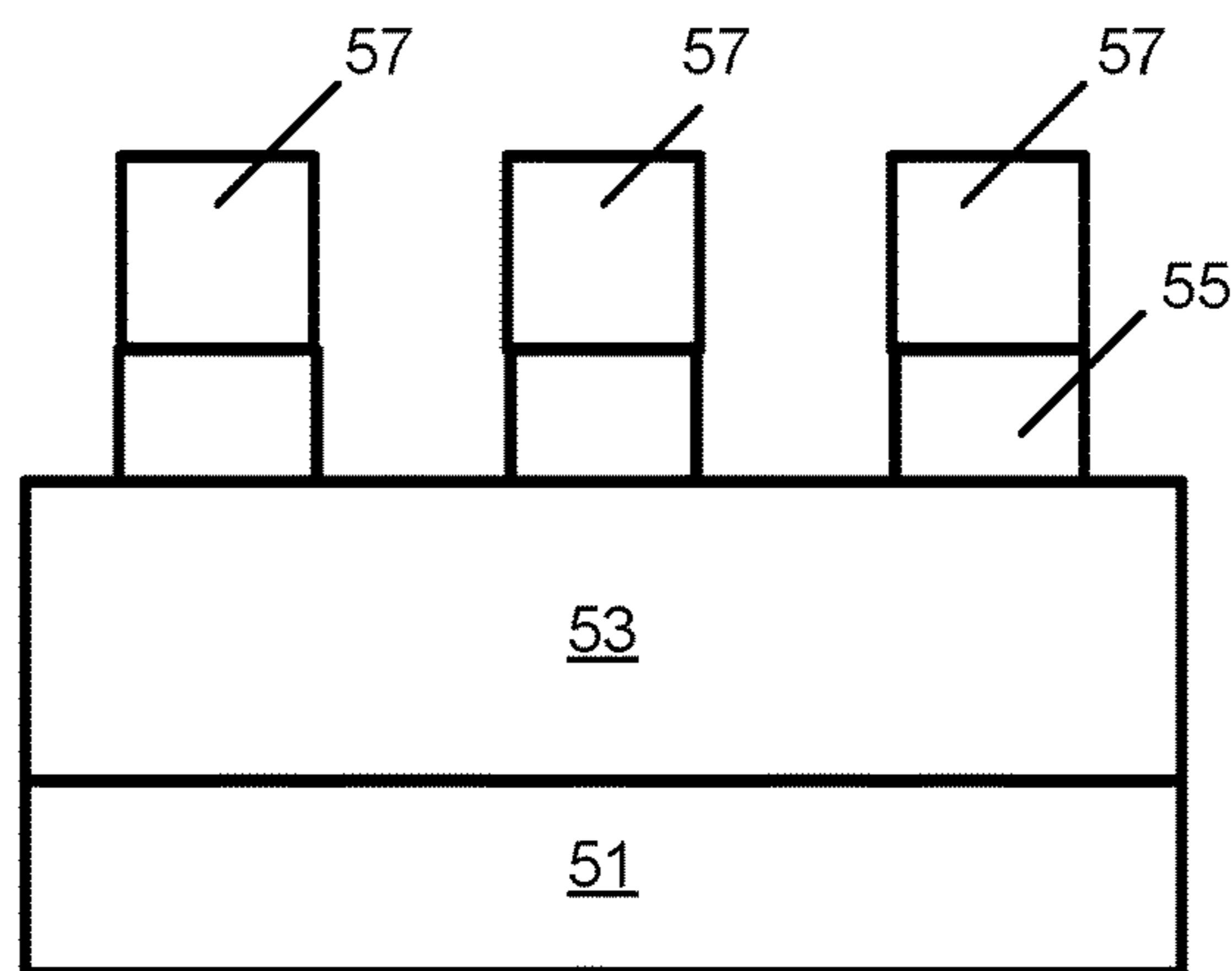
*Fig. 5J*



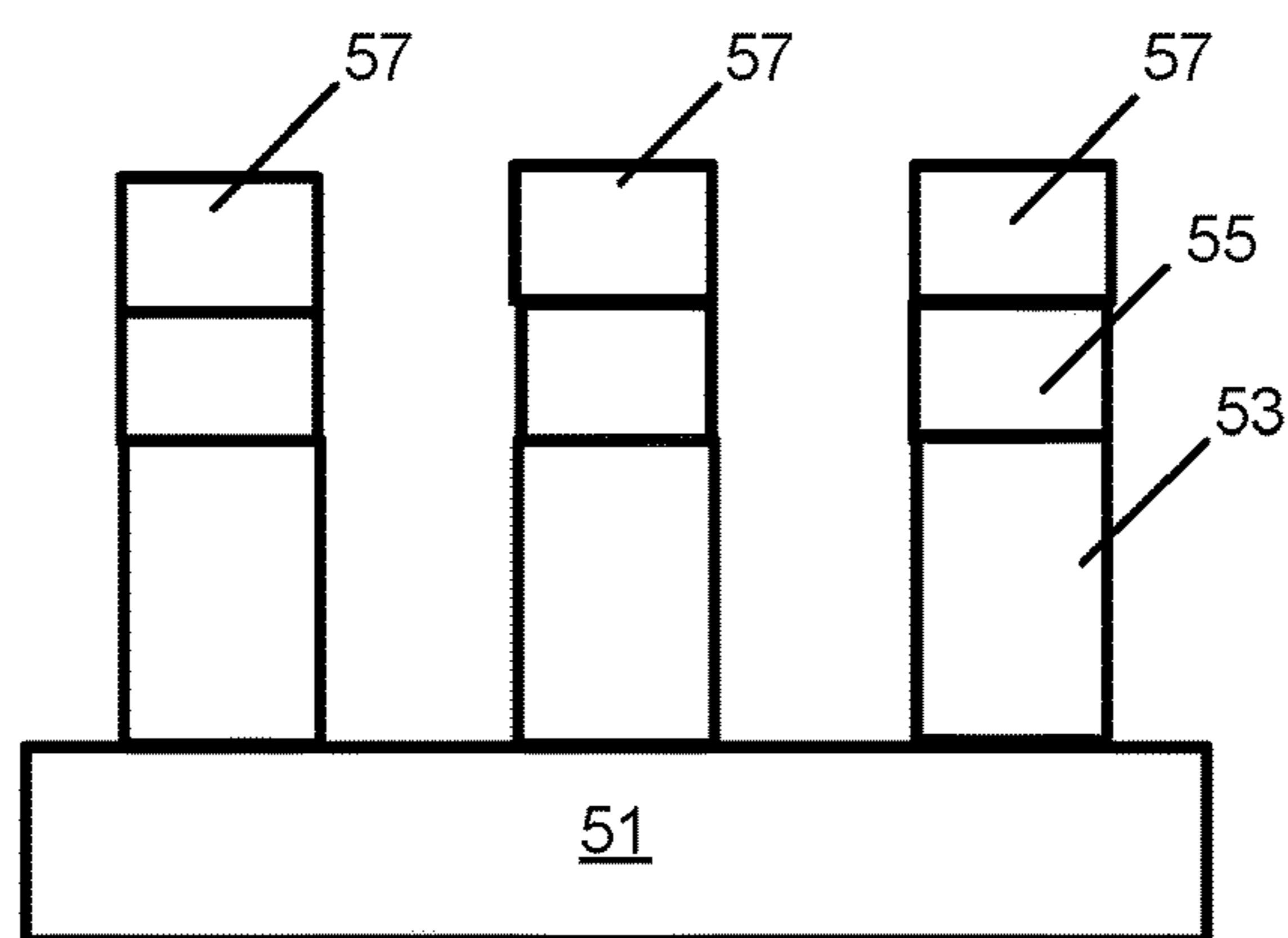
*Fig. 5K*



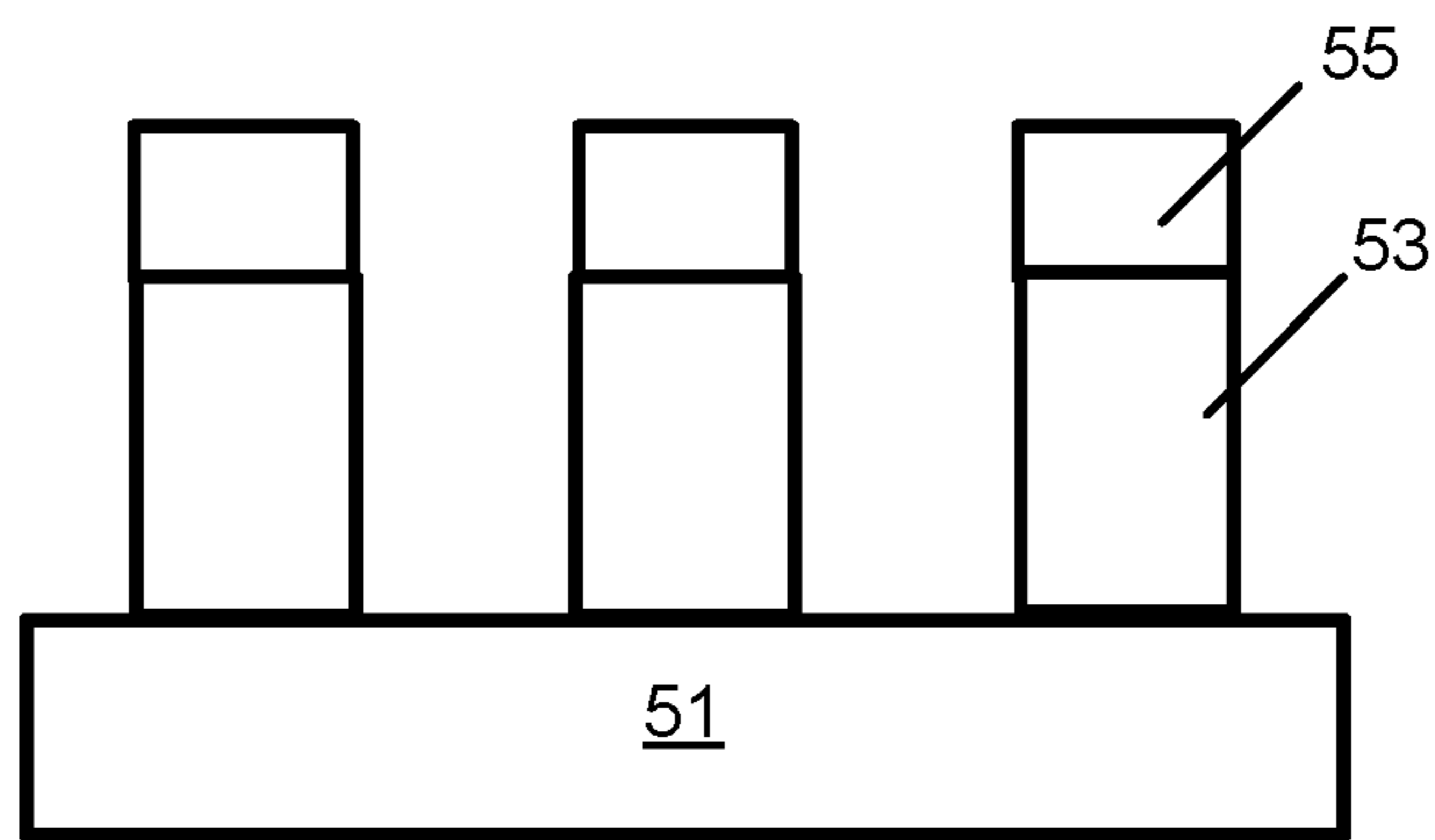
*Fig. 5L*



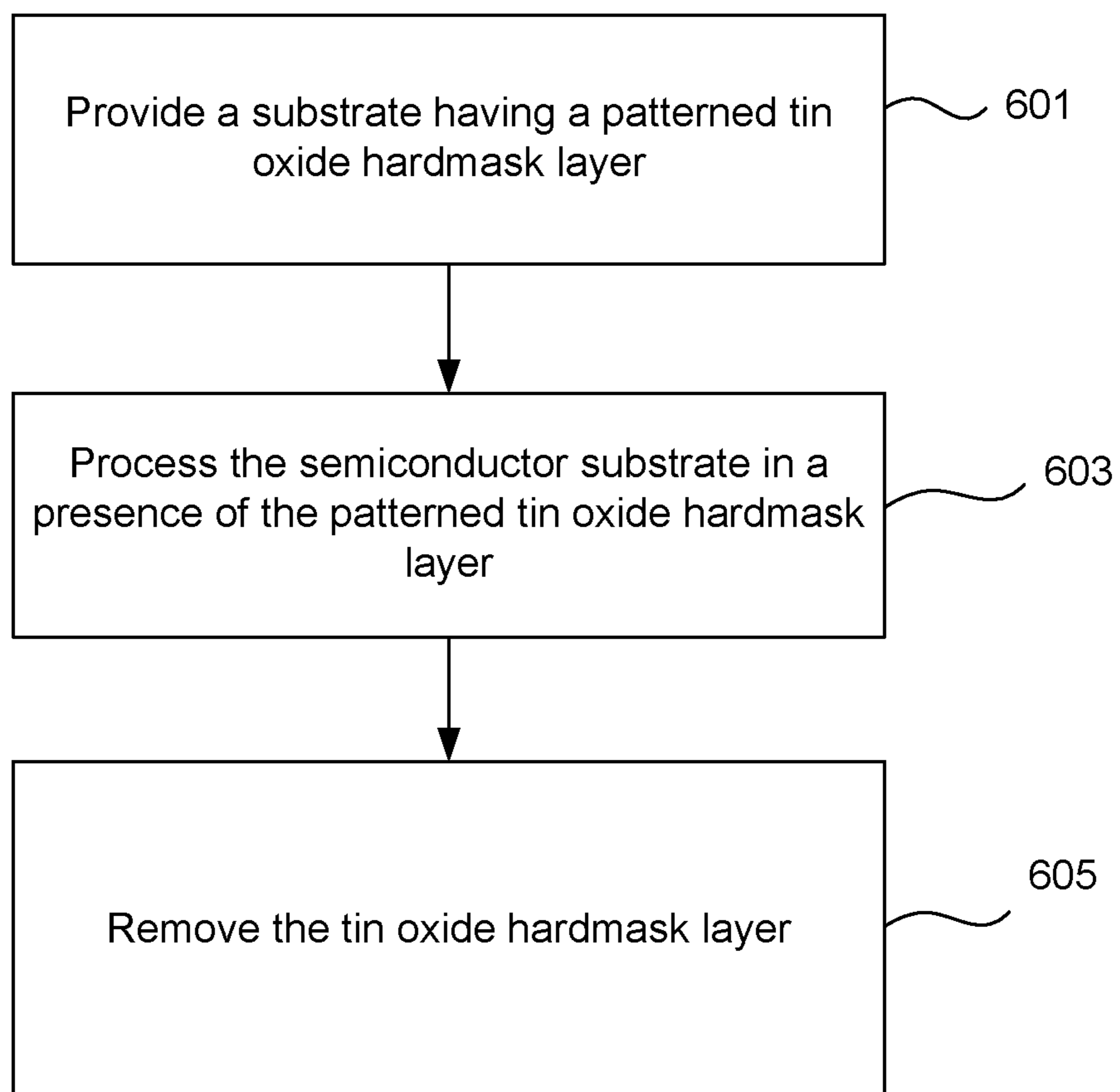
*Fig. 5M*



*Fig. 5N*

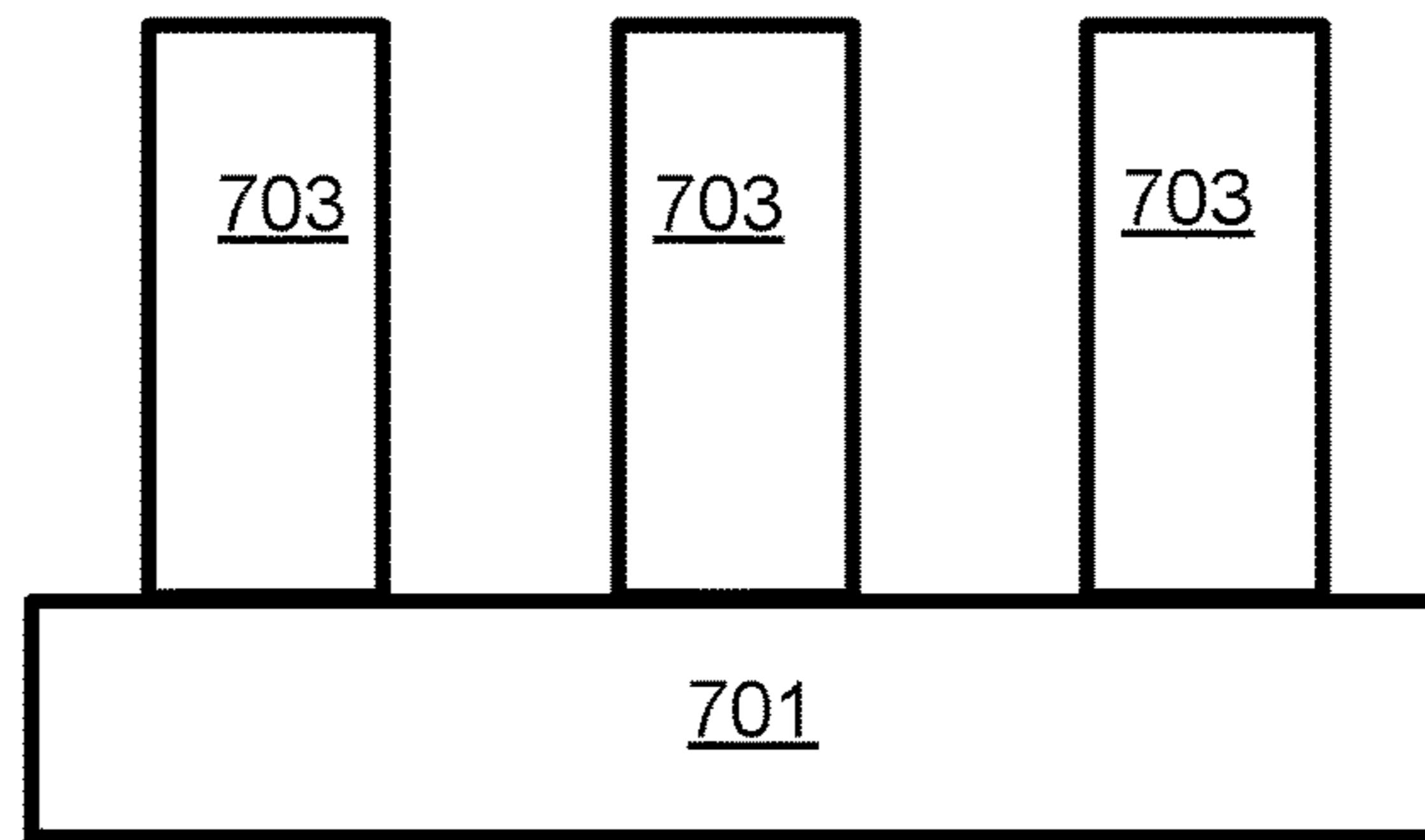


*Fig. 50*

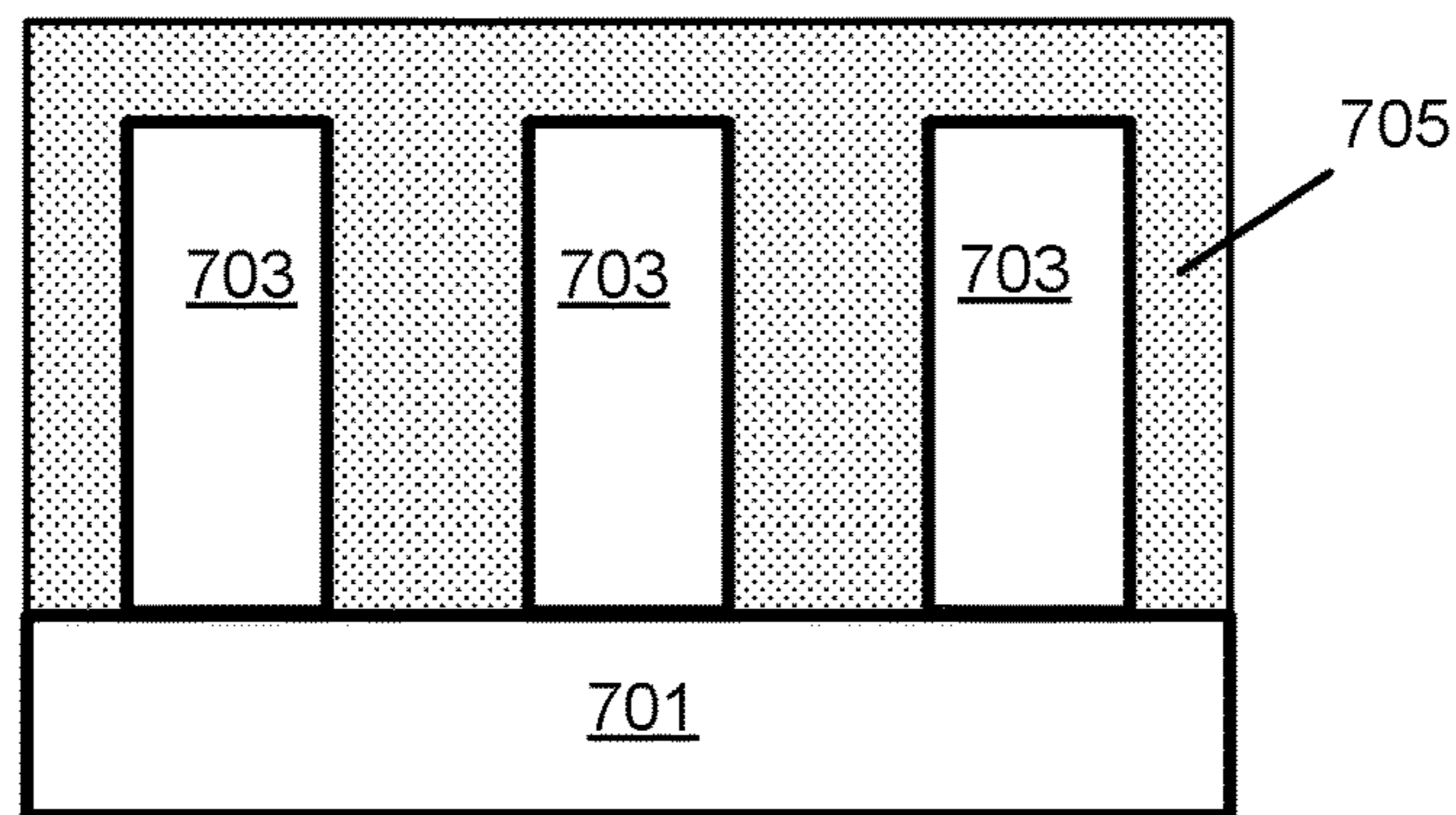


*Fig. 6*

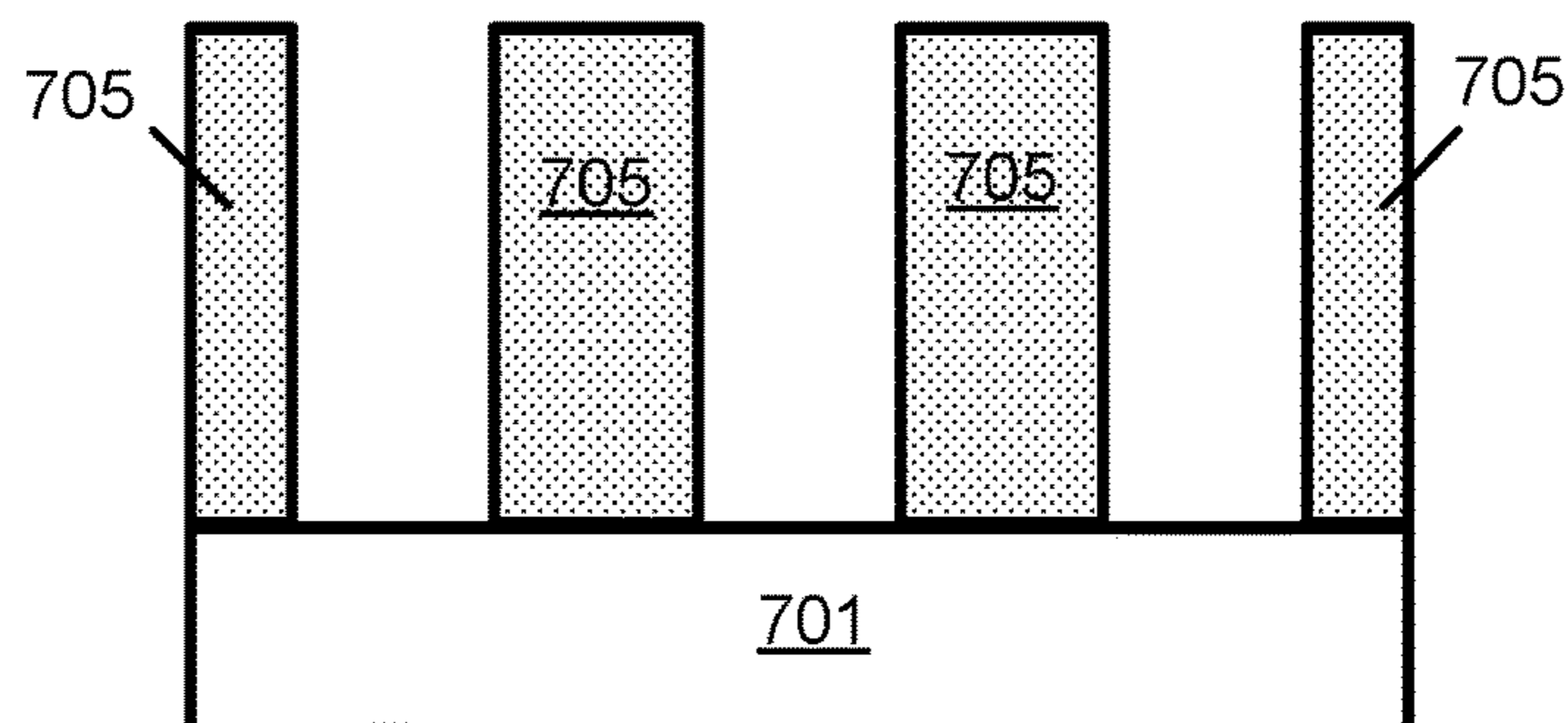




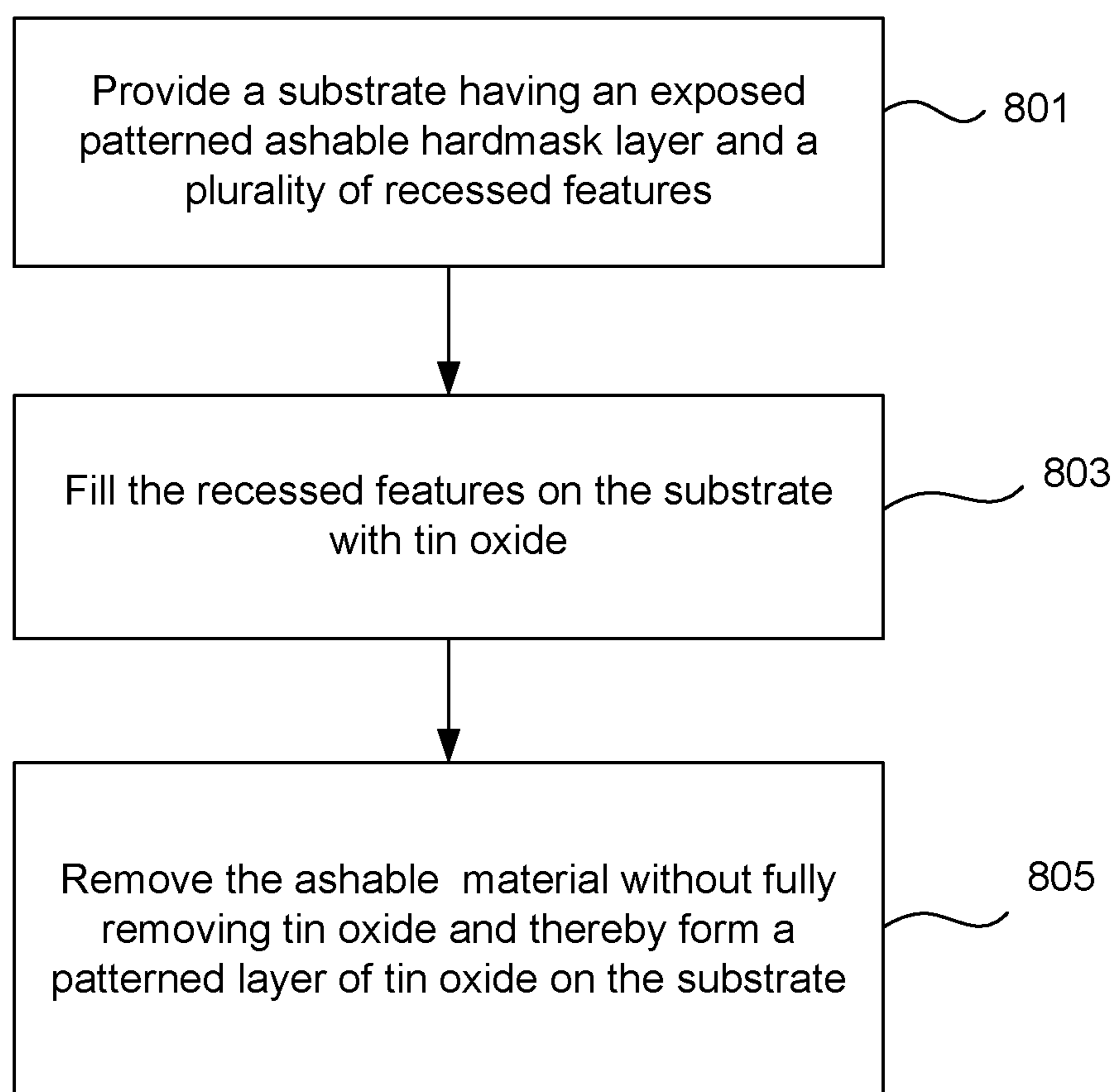
*Fig. 7A*

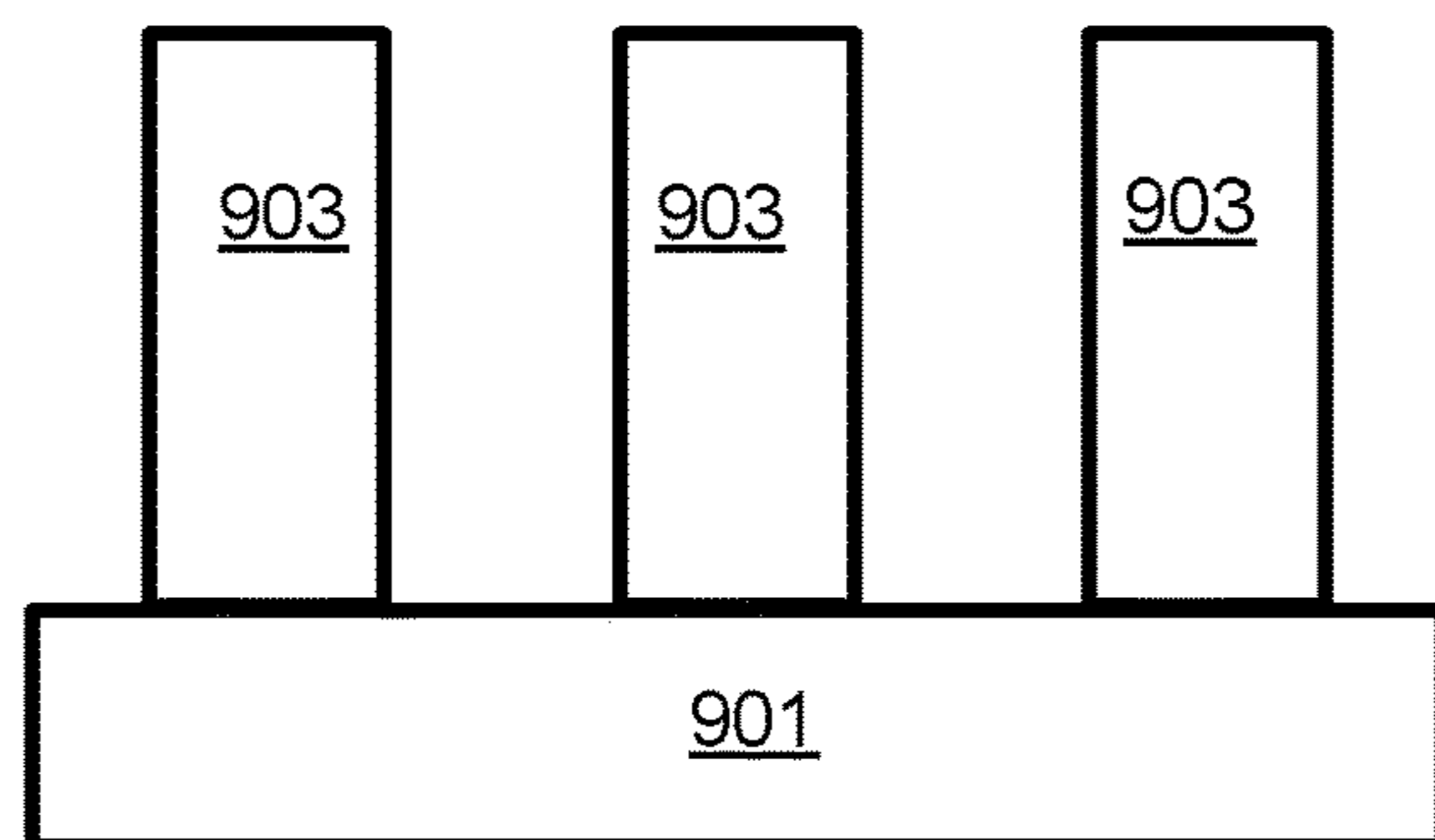


*Fig. 7B*

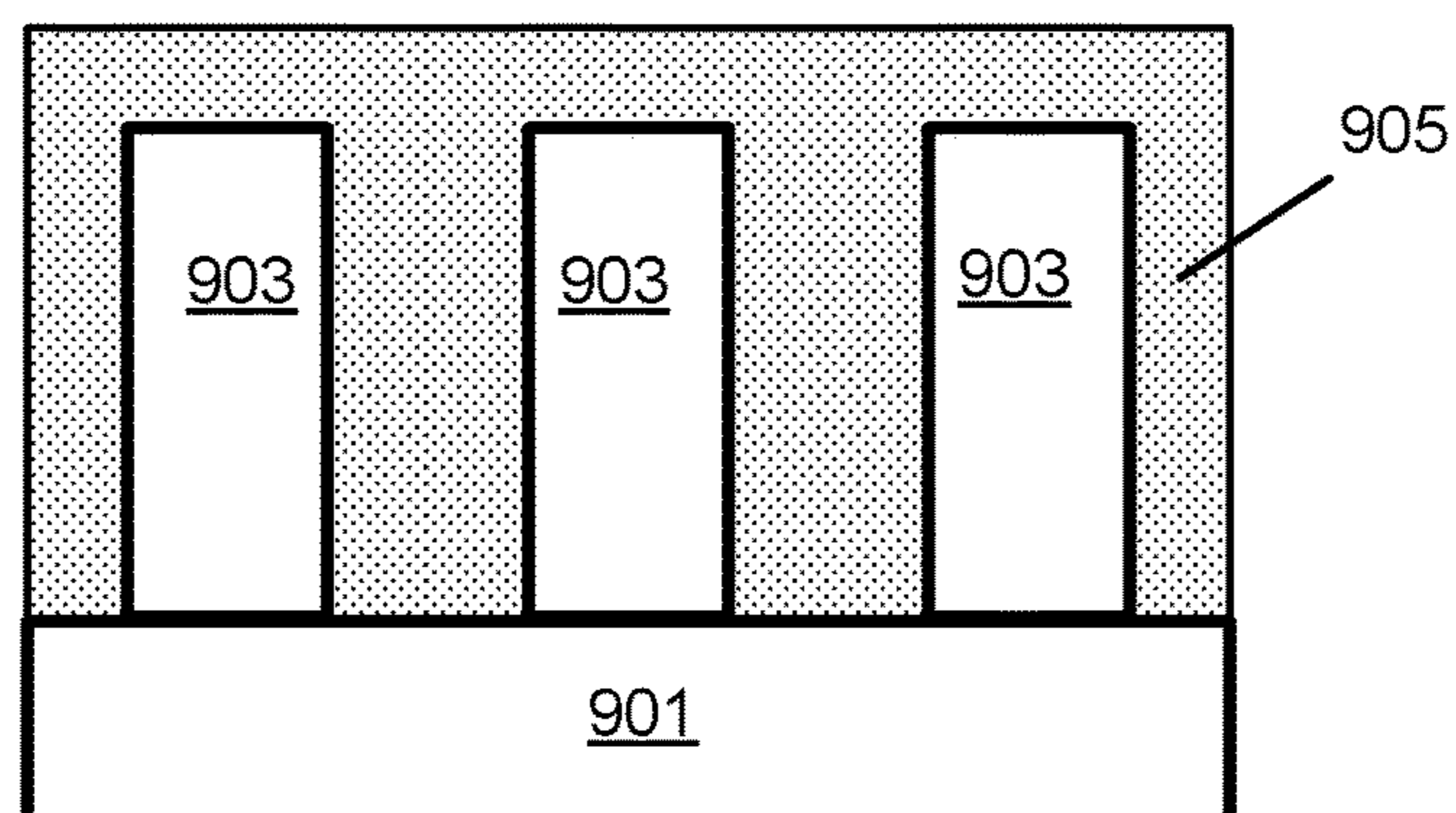


*Fig. 7C*

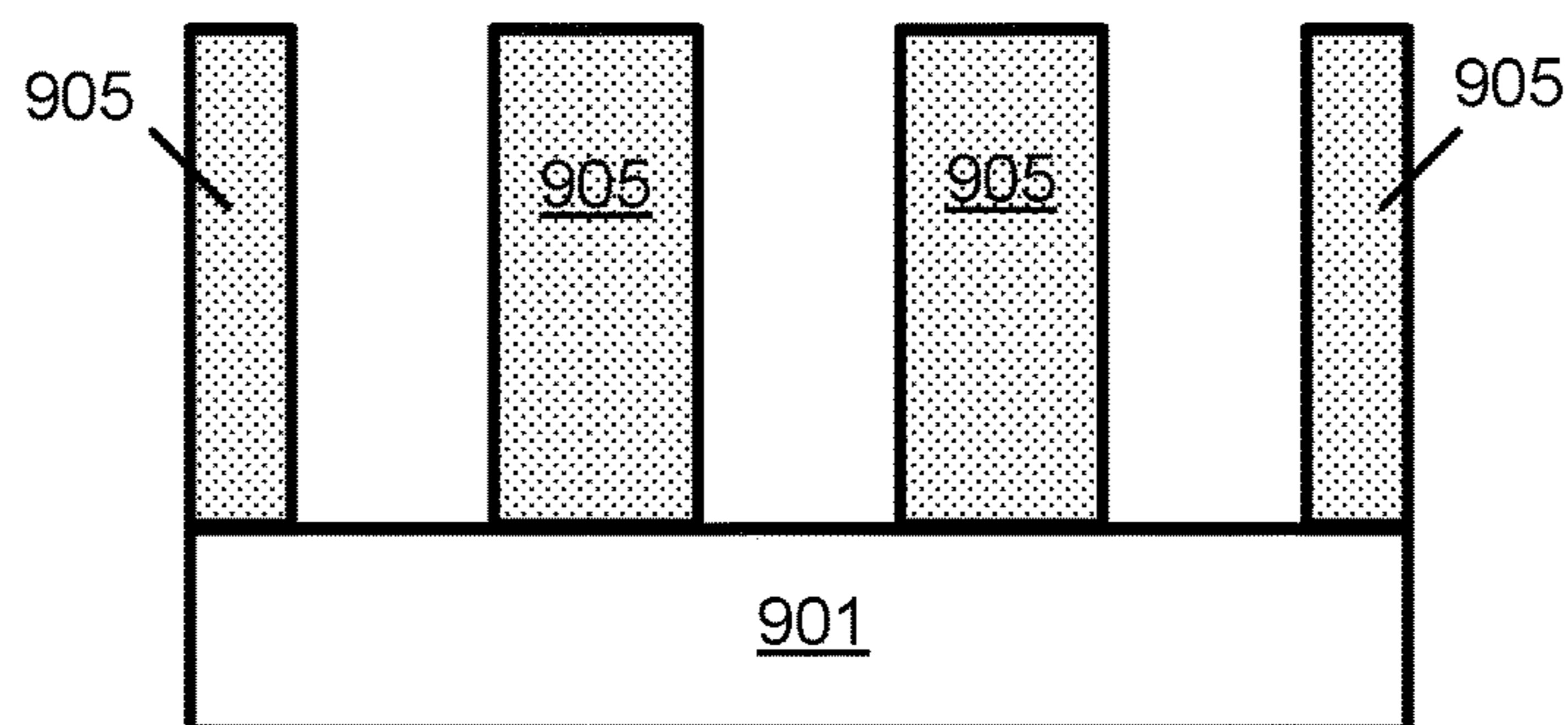
*Fig. 8*



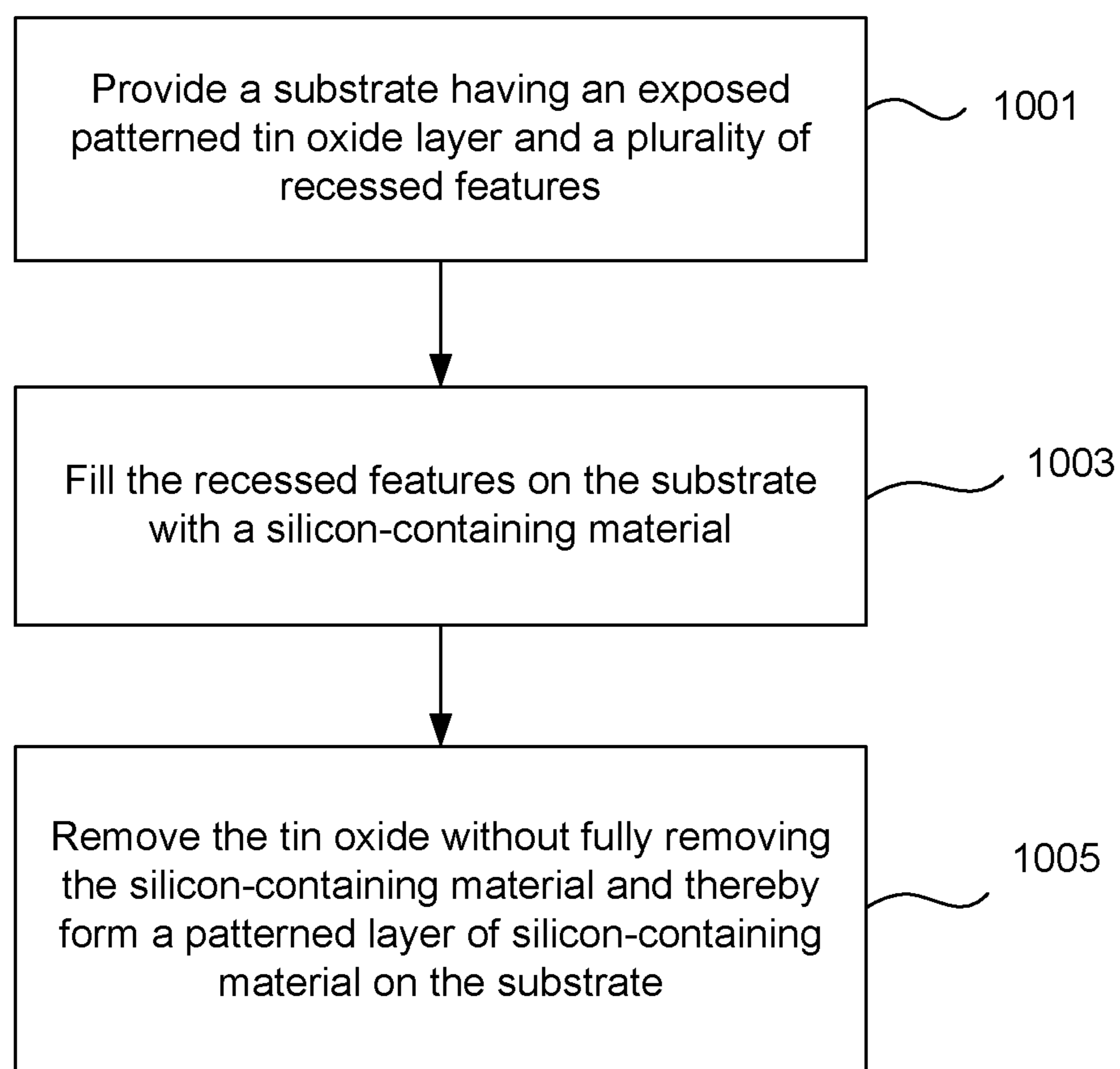
*Fig. 9A*



*Fig. 9B*

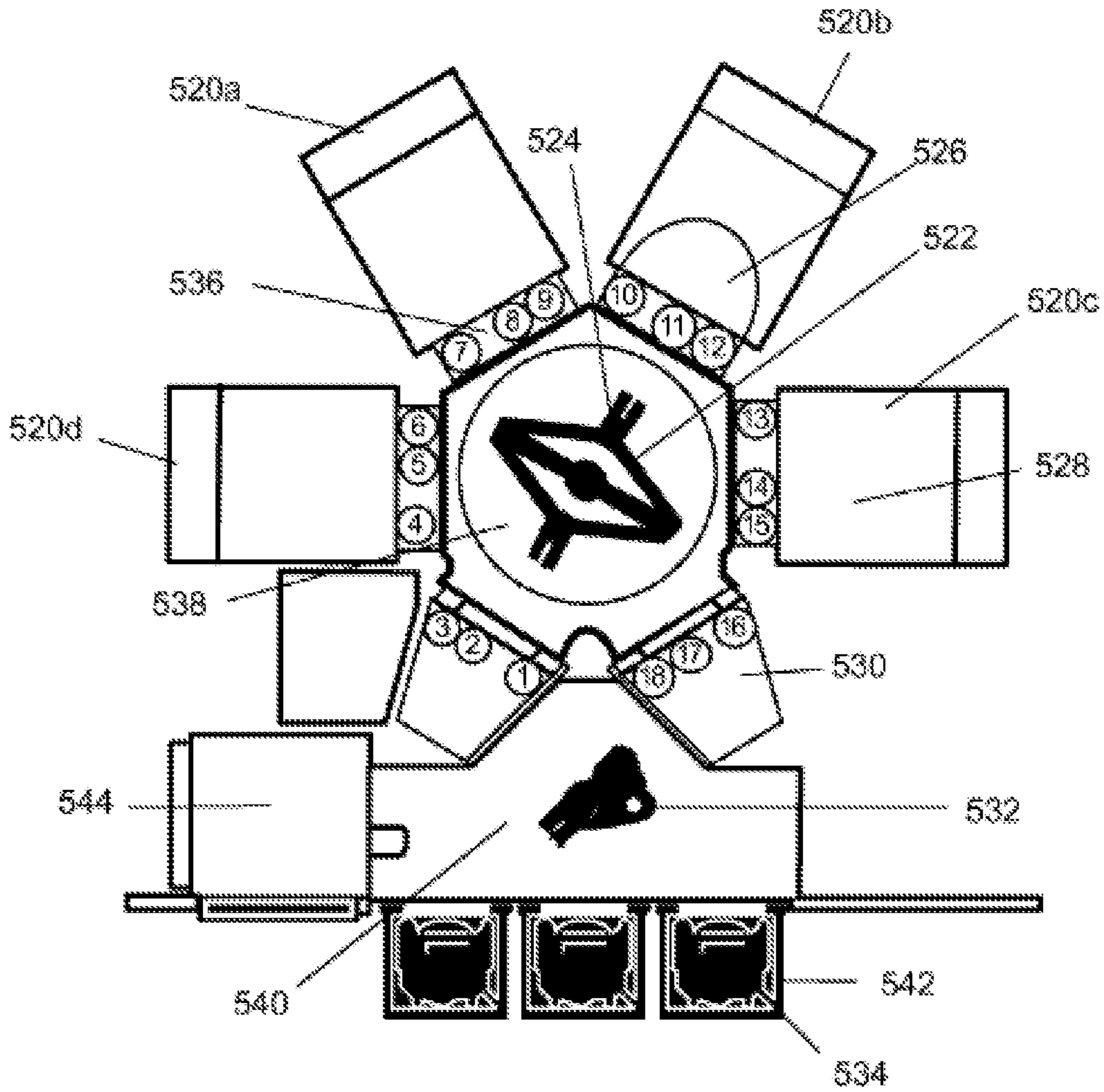


*Fig. 9C*



*Fig. 10*





**FIG. 12**

## TIN OXIDE FILMS IN SEMICONDUCTOR DEVICE MANUFACTURING

### CROSS-REFERENCE TO RELATED APPLICATIONS

This application claims the benefit of U.S. Provisional Patent Application No. 62/460,573, filed on Feb. 17, 2017, titled "Tin Oxide Films in Semiconductor Device Manufacturing" naming Tan et al. as inventors, and of U.S. Provisional Patent Application No. 62/479,709, filed on Mar. 31, 2017, titled "Tin Oxide Films in Semiconductor Device Manufacturing" naming Tan et al. as inventors which are herein incorporated by reference in their entirety.

### FIELD OF THE INVENTION

This invention pertains to methods of semiconductor device manufacturing. Specifically, embodiments of this invention pertain to methods of using tin oxide films in semiconductor processing.

### BACKGROUND

In integrated circuit (IC) fabrication, deposition and etching techniques are used for forming patterns of materials, such as for forming metal lines embedded in dielectric layers. Some patterning schemes involve the use of spacers that enable precise patterning and formation of small-scale features. Spacers are formed on a substrate, such that they are separated by defined distances (typically determined by previous patterning), and are used as masks for patterning of underlying layers. The materials of spacers and of surrounding layers are selected to have appropriate etch selectivity that would enable both formation of spacers, and patterning of underlying layers. After the patterning is completed, the spacers are removed by etching, and are not part of the final fabricated semiconductor device.

Spacers are used for patterning in a variety of applications, including formation of dynamic random-access memory (DRAM), patterning fins in fin field effect transistors (finFETs), and in back end of line (BEOL) processing.

### SUMMARY

In one aspect, a method of processing a semiconductor substrate is provided. In some embodiments the method includes: (a) providing a semiconductor substrate having a plurality of protruding features, the protruding features having horizontal surfaces and sidewalls; (b) forming a tin oxide layer on the horizontal surfaces and the sidewalls of the protruding features (e.g., conformally depositing tin oxide to a thickness of between about 5-30 nm); (c) forming a passivation layer over the tin oxide layer at the sidewalls of the protruding features; and (d) after the passivation layer is formed, etching and removing tin oxide from the horizontal surfaces of the protruding features and thereby exposing a material of the protruding features, without removing tin oxide residing at the sidewalls of the protruding features. In some embodiments the passivation layer has a thickness of 1-5 nm. In some embodiments the material of the protruding features exposed in (d) is selected from the group consisting of a silicon-containing material (e.g., silicon oxide or another silicon-containing compound), a carbon-containing material (e.g., amorphous carbon or photoresist), and a metal oxide (e.g., titanium oxide). In some embodiments, the semiconductor substrate provided in (a) includes

a material selected from the group consisting of silicon oxide, titanium oxide, zirconium oxide, and tungsten oxide between the protruding features.

In some embodiments, the step of etching and removing tin oxide from horizontal surfaces of the protruding features includes etching the tin oxide using a hydrogen-based etch chemistry that results in a formation of a tin hydride. For example, such etching may include contacting the semiconductor substrate with a plasma-activated hydrogen-containing reactant selected from the group consisting of H<sub>2</sub>, HBr, NH<sub>3</sub>, H<sub>2</sub>O, a hydrocarbon, and combinations thereof.

In some embodiments, the step of etching and removing tin oxide from horizontal surfaces of the protruding features includes using a chlorine-based etch chemistry that comprises exposing the semiconductor substrate to a plasma-activated chlorine-containing reactant selected from the group consisting of Cl<sub>2</sub>, BCl<sub>3</sub>, and combinations thereof. In some embodiments, the step of etching and removing tin oxide from horizontal surfaces of the protruding features includes etching tin oxide using a chlorine-based etch chemistry followed by etching the tin oxide using a hydrogen-based etch chemistry. For example this step may include etching the tin oxide layer using a plasma formed in a gas comprising Cl<sub>2</sub> and BCl<sub>3</sub>, followed by etching the tin oxide layer with a plasma formed in an H<sub>2</sub>-containing gas.

In one implementation, the material of the protruding features exposed in during the tin oxide etch is selected from the group consisting of SiO<sub>2</sub>, SiN, SiOC, SiC, SiCN, SiCNO, and SiOC, and the tin oxide etching includes using a hydrogen-based etch chemistry that results in a formation of a tin hydride. In one embodiment, the protruding features silicon protruding features covered with silicon oxide and removing the tin oxide layer from the horizontal surfaces of the protrusions includes etching tin oxide using a hydrogen-based etch chemistry that results in a formation of a tin hydride, and exposing the underlying silicon oxide material.

In another embodiment the protruding features are carbon protruding features or photoresist protruding features. In another embodiment the protruding features are metal oxide protruding features selected from the group consisting of tantalum oxide (TaO), titanium oxide (TiO), tungsten oxide (WO), zirconium oxide (ZrO), and hafnium oxide (HfO).

In some embodiments forming the passivation layer over the tin oxide layer at the sidewalls of the protruding features includes depositing a passivation material over both the horizontal surfaces and the sidewalls of the protruding features, followed by removal of the passivation material from the horizontal surfaces of the protruding features. In one implementation, forming the passivation layer over the tin oxide layer at the sidewalls of the protruding features includes depositing a silicon-containing passivation material over both the horizontal surfaces and the sidewalls of the protruding features, followed by removal of the silicon-containing passivation material from the horizontal surfaces of the protruding features using a fluorocarbon-based etch chemistry. In another implementation, forming the passivation layer over the tin oxide layer at the sidewalls of the protruding features includes depositing a carbon-containing passivation material over both the horizontal surfaces and the sidewalls of the protruding features, followed by removal of the carbon-containing passivation material from the horizontal surfaces.

In some embodiments forming the passivation layer over the tin oxide layer at the sidewalls of the protruding features includes converting an outer portion of the tin oxide layer to a tin-containing passivation material selected from the group consisting of tin nitride (SnN), tin bromide (SnBr), and tin

fluoride (SnF). In one example forming the passivation layer over the tin oxide layer at the sidewalls of the protruding features includes converting an outer portion of the tin oxide layer to tin nitride by contacting the substrate with a nitrogen-containing reactant in a plasma.

After the tin oxide layer is removed from the horizontal surfaces, the process may follow by removing the protruding features without completely removing the tin oxide layer that resided at the sidewalls of the protruding features, thereby forming tin oxide spacers.

The method may also include: applying photoresist to the substrate; exposing the photoresist to light; patterning the photoresist and transferring the pattern to the substrate; and selectively removing the photoresist from the substrate.

In another aspect a partially fabricated semiconductor substrate is provided, wherein the semiconductor substrate includes a plurality of spacers, wherein each spacer includes a layer of tin oxide and a layer of a passivation material.

In another aspect, a system for processing a semiconductor substrate is provided. In one embodiment the system includes: one or more deposition chambers; one or more etch chambers; and a system controller comprising program instructions for: (i) causing a deposition of a tin oxide layer over horizontal surfaces and sidewalls of a plurality of protruding features on the semiconductor substrate; (ii) causing a formation of a passivation layer on the tin oxide layer at the sidewalls of the protruding features, and (ii) causing a removal of the tin oxide layer from horizontal surfaces of the protruding features, without causing a removal of the tin oxide layer over the sidewalls of the protruding features.

In another aspect methods for processing a semiconductor substrate using tin oxide hardmasks are provided. In one embodiment a method for processing a semiconductor substrate includes: forming a patterned tin oxide hardmask layer on the semiconductor substrate by forming a patterned layer over an unpatterned tin oxide hardmask layer and transferring the pattern to the tin oxide hardmask layer; and processing the semiconductor substrate in a presence of the tin oxide hardmask layer.

In one implementation processing the semiconductor substrate includes etching an exposed material that is not covered by the patterned tin oxide hardmask. In one embodiment, the exposed material that is not covered by the patterned tin oxide hardmask is a silicon-containing material and the etching includes exposing the substrate to a fluorine-based etch chemistry (e.g., fluorocarbon-based etch chemistry). In another embodiment, the exposed material that is not covered by the patterned tin oxide hardmask is a carbon-containing material and the etching includes exposing the substrate to an oxygen-based etch chemistry.

In another aspect, a method for processing a semiconductor substrate, is provided, where the method includes: (a) providing a semiconductor substrate having an exposed patterned ashable layer, wherein the patterned ashable layer comprises a plurality of recessed features with an exposed target material located at the bottom of each recessed feature; (b) filling the recessed features with tin oxide and forming a tin oxide overburden over the ashable layer; (c) removing the tin oxide overburden to expose the underlying ashable material; and (d) removing the ashable material to expose an underlying target layer without fully removing tin oxide. In one embodiment the ashable material is a carbon-containing material (e.g., carbon), and (d) includes removing the ashable material using an oxygen-based etch chemistry.

In another aspect, a method for processing a semiconductor substrate is provided, where the method includes: (a)

providing a semiconductor substrate having a patterned tin oxide layer, wherein the patterned tin oxide layer comprises a plurality of recessed features; (b) filling the recessed features with a silicon-containing material, wherein the silicon-containing material is silicon or silicon-containing compound, and forming an overburden of the silicon-containing material over the tin oxide layer; (c) removing the overburden to expose the underlying tin oxide; and (d) removing the tin oxide without fully removing the silicon-containing material. In one implementation removing the tin oxide without fully removing the silicon-containing material includes etching tin oxide using a hydrogen-based etch chemistry (e.g. plasma formed in H<sub>2</sub>).

In another aspect, a method of processing a semiconductor substrate includes: (a) providing a semiconductor substrate having a plurality of protruding features; (b) depositing a tin oxide layer over horizontal surfaces and sidewalls of the protruding features; and (c) etching and removing tin oxide from the horizontal surfaces of the protruding features, without completely removing tin oxide residing at the sidewalls of the protruding features, wherein the etching includes exposing the semiconductor substrate to a hydrogen-based etch chemistry to convert tin oxide to a tin hydride.

In another aspect a method of processing a semiconductor substrate includes: (a) providing a semiconductor substrate having a plurality of protruding features; (b) depositing a tin oxide layer over horizontal surfaces and sidewalls of the protruding features; and (c) etching and completely removing tin oxide from the horizontal surfaces of the protruding features, without completely removing tin oxide residing at the sidewalls of the protruding features, wherein the etching comprises exposing the semiconductor substrate to a chlorine-based etch chemistry to convert tin oxide to a tin chloride.

In another aspect a method of processing a semiconductor substrate includes: (a) providing a substrate having a tin oxide layer, an exposed layer of patterned photoresist over the tin oxide layer, and a layer of an underlying material below the tin oxide layer, wherein the tin oxide is exposed at locations that are not covered by the patterned photoresist; and (b) selectively etching the tin oxide in a presence of photoresist, and exposing the underlying material, wherein the etching is selective to both photoresist and the underlying material. In some embodiments, selectively etching the tin oxide includes exposing the substrate to a hydrogen-based plasma etch chemistry with a carbon-containing additive resulting in a formation of a carbon-containing polymer on the semiconductor substrate during the etch. In one implementation selectively etching the tin oxide comprises exposing the semiconductor substrate to a plasma formed in a process gas comprising H<sub>2</sub> and a hydrocarbon. In some embodiments, this tin oxide etch chemistry provides an etch selectivity of at least 100 to photoresist, and of at least 10 to the underlying material. In some embodiments the underlying material is selected from the group consisting of silicon (Si), a silicon-containing compound, and a carbon-containing material. In one implementation the underlying material is amorphous silicon, and the method further includes selectively etching amorphous silicon exposed in (b) in a presence of tin oxide. In another implementation the underlying material comprises tungsten (W) and carbon (C), and the method further includes selectively etching the underlying material exposed in (b) in a presence of tin oxide. In some embodiments, after selective etching of tin oxide the method further includes: (c) selectively etching the exposed underlying material in a presence of tin oxide; and (d) removing



## 5

the tin oxide from the semiconductor substrate by exposing the semiconductor substrate to a plasma formed in a process gas consisting essentially of  $H_2$ .

In other aspects, selective etching methods are provided. In one aspect a method of processing a semiconductor substrate includes: (a) providing a semiconductor substrate having an exposed layer of tin oxide; (b) selectively etching the tin oxide in a presence of a material selected from the group consisting of photoresist, silicon (Si), carbon, and a carbon-containing material, by exposing the semiconductor substrate to a plasma formed in a process gas comprising  $H_2$  and a hydrocarbon.

In another aspect, a method of processing a semiconductor substrate includes: (a) providing a semiconductor substrate having an exposed layer of tin oxide; (b) selectively etching the tin oxide in a presence of a material selected from the group consisting of silicon (Si), carbon, a carbon-containing material, metal, metal oxide and a metal nitride, using a hydrogen-based etch.

In another aspect, a method of processing a semiconductor substrate includes: (a) providing a semiconductor substrate having an exposed layer of tin oxide; and (b) selectively etching the tin oxide in a presence of a material selected from the group consisting of silicon (Si), a silicon-containing compound, photoresist, carbon (C), a carbon-containing material, metal, metal oxide and a metal nitride, by exposing the semiconductor substrate to a plasma formed in a process gas comprising a hydrogen-containing reactant selected from the group consisting of HBr, a hydrocarbon,  $NH_3$ , and  $H_2O$ , to form a tin hydride during the etching.

In another aspect, a method of processing a semiconductor substrate includes: (a) providing a semiconductor substrate having an exposed layer of a material selected from the group consisting of titanium oxide, and a tungsten-containing material; and (b) selectively etching the tin oxide in a presence of the material selected from the group consisting of titanium oxide and the tungsten-containing material.

In another aspect an apparatus is provided, where the apparatus includes a process chamber and a controller having program instructions for causing any of the methods provided herein.

In another aspect, a semiconductor device is provided, wherein the semiconductor device includes a tin oxide layer and a plurality of other materials in any configuration described herein.

These and other aspects of implementations of the subject matter described in this specification are set forth in the accompanying drawings and the description below.

## BRIEF DESCRIPTION OF THE DRAWINGS

FIGS. 1A-1F show schematic cross-sectional views of a semiconductor substrate undergoing processing that involves spacer formation.

FIG. 2 is a process flow diagram for a method according to an embodiment provided herein.

FIGS. 3A-3E show schematic cross-sectional views of a semiconductor substrate undergoing processing according to an embodiment provided herein.

FIG. 4 is a process flow diagram for a method of forming tin oxide spacers according to an embodiment provided herein.

FIGS. 5A-5C show schematic cross-sectional views of a semiconductor substrate undergoing processing according to an embodiment provided herein.

## 6

FIGS. 5D-5G show schematic cross-sectional views of a semiconductor substrate undergoing processing according to another embodiment provided herein.

FIGS. 5H-5K show schematic cross-sectional views of a semiconductor substrate undergoing processing according to another embodiment provided herein.

FIGS. 5L-5O show schematic cross-sectional views of a semiconductor substrate undergoing processing according to another embodiment provided herein.

FIG. 6 is a process flow diagram for a method of semiconductor processing according to an embodiment provided herein.

FIGS. 7A-7C show schematic cross-sectional views of a semiconductor substrate undergoing processing according to an embodiment provided herein.

FIG. 8 is a process flow diagram for a method according to an embodiment provided herein.

FIGS. 9A-9C show schematic cross-sectional views of a semiconductor substrate undergoing processing according to an embodiment provided herein.

FIG. 10 is a process flow diagram for a method according to an embodiment provided herein.

FIG. 11 is a schematic presentation of an apparatus that is suitable for etching tin oxide using etch chemistries provided herein.

FIG. 12 shows a schematic view of a multi-station processing system according to an embodiment provided herein.

## DETAILED DESCRIPTION OF THE PREFERRED EMBODIMENTS

Methods that employ tin oxide films in semiconductor device manufacturing are provided. The methods utilize a number of etching processes with tunable etch rates and selectivities that allow integration of tin oxide films into process schemes that employ a wide variety of materials, such as silicon-containing compounds (e.g., silicon oxide ( $SiO_2$ ), silicon carbide (SiC), silicon nitride (SiN), silicon oxycarbide (SiOC), silicon oxynitride (SiNO), silicon oxycarbonitride (SiCNO), and silicon carbonitride (SiCN)), elemental silicon (Si), carbon (including amorphous carbon and diamond-like carbon), photoresist, carbon-containing compounds (e.g., organic polymers, metal carbides, tungsten-containing carbon), metals (e.g., tungsten), metal oxides (e.g., titanium oxide, hafnium oxide, zirconium oxide, tantalum oxide), and metal nitrides (e.g., tantalum nitride (TaN) and titanium nitride (TiN)). In some embodiments tin oxide is etched in a presence of any of these materials with an etch selectivity of at least about 10:1, such as at least about 20:1. In some embodiments, any of these materials is etched in a presence of tin oxide with an etch selectivity of at least about 10:1, such as at least about 20:1.

In some embodiments, tin oxide is used in patterning processes, where the tin oxide film is a spacer, or a hardmask (e.g., a middle layer positioned below photoresist and above a target layer). For example, tin oxide can be a spacer in self-aligned spacer-assisted patterning, a middle layer in self-aligned double patterning (SADP) or self-aligned quadruple patterning (SAQP), a contact hole hard mask, an extreme UV (EUV) hardmask, a reverse tone mask, or a back end of the line (BEOL) hard mask. In conjunction with selective etching processes, tin oxide meets stringent critical dimension (CD)/profile and selectivity requirements that are imposed by these applications. The etching processes can be implemented on a variety of tools that allow plasma etching, such as Kryo® and Flex™ etch tools provided by Lam Research Corporation.

Tin oxide can be etched selectively to a wide variety of materials using hydrogen-based etches that convert tin oxide to volatile tin hydride products (e.g., tin tetrahydride). The term “tin hydride” as used herein includes a plurality of tin hydrides (compounds with tin-hydrogen bonding) and is not limited only to tin tetrahydride (SnH<sub>4</sub>). Terms like “tin chloride” and “silicon fluoride” similarly may include multiple chlorides and fluorides. Tin tetrahydride, unlike hydrides of many other metals, has a low boiling point, and therefore can be easily removed from the process chambers by purging and/or evacuation thereby making hydrogen-based etch a particularly attractive process for selective tin oxide etching.

Tin oxide, as used herein, refers to materials that include tin (Sn) and oxygen (O), and may optionally include hydrogen. Tin oxide, as used herein, may further include small amounts of other elements, such as carbon, and nitrogen, where the total amount of other elements is 10 atomic % or less (where hydrogen is not included in the calculation of the content). For example ALD-deposited tin oxide can contain about 0.5-5 atomic % carbon. Tin oxide can be deposited, for example, by ALD, PECVD, or PVD. The stoichiometry of tin oxide generally can vary. In some embodiments the atomic ratio of tin to oxygen is about 1:2 (SnO<sub>2</sub>). It is understood that small deviations from 1:2 tin to oxygen stoichiometry are possible in SnO<sub>2</sub> and are within the scope of SnO<sub>2</sub> structure. For example, O to Sn atomic ratio is between about 2.0-2.3 in some examples of SnO<sub>2</sub>. Tin oxides with O to Sn ratio of between about 1.5-2.5 are within the scope of SnO<sub>2</sub> material, as used herein. Tin oxide materials described herein are distinct from indium tin oxide materials, and other mixed oxides.

It is understood that in other chemical compounds as used herein, stoichiometry may vary, unless it is specified. For example, formulas such as SiN and HfO specify the elements that are present but not the stoichiometry. Further, it is understood that materials described herein may include hydrogen (even if not specified in the formula) and small amounts of dopants not explicitly listed in the chemical name (such as less than 10 atomic % of a dopant).

The term “semiconductor substrate” as used herein refers to a substrate at any stage of semiconductor device fabrication containing a semiconductor material anywhere within its structure. It is understood that the semiconductor material in the semiconductor substrate does not need to be exposed. Semiconductor wafers having a plurality of layers of other materials (e.g., dielectrics) covering the semiconductor material, are examples of semiconductor substrates. The following detailed description assumes the disclosed implementations are implemented on a wafer. However, the disclosed implementations are not so limited. The work piece may be of various shapes, sizes, and materials. In addition to semiconductor wafers, other work pieces that may take advantage of the disclosed implementations include various articles such as printed circuit boards and the like.

In some embodiments, provided selective etch chemistries are used to remove certain materials or features on a substrate without removing other materials or features. As used herein, the etch chemistry “removes” a material or feature when at least 90% (such as 100%) of the material or feature is removed (referring to thickness in vertical direction). The term “without removing”, as used herein means that at least 50% of material or feature (such as at least 80%) remains after the etch, where % refers to thickness in a vertical direction.

In some embodiments provided methods are used to remove materials from horizontal surfaces without removing materials residing at sidewalls of protruding features. It is understood that horizontal surfaces, as used herein, include surfaces with local deviations from horizontal plane, such as convex caps on top of protruding features.

A variety of etch chemistries have been developed for selective etching of tin oxide in a presence of other materials, as well as for selective etching of other materials in a presence of tin oxide. Selective etching of tin oxide in a presence of another material refers to tin oxide etching, wherein the ratio of the etch rate of tin oxide to the etch rate of the other material is greater than one, and wherein the other material is exposed to the same etch chemistry as tin oxide at any time of the etching process. For example, the other material may be exposed when the etching begins, or may become exposed during the course of etching. Etch selectivity for selective etching of tin oxide in a presence of another material refers to a ratio of an etch rate of tin oxide to an etch rate of the other material for a given chemistry. For example, tin oxide can be selectively etched in a presence of a silicon-containing compound using a hydrogen-based etch chemistry with an etch selectivity of greater than 50.

Similarly, selective etching of a material in a presence of tin oxide refers to such etching of that material, where the ratio of an etch rate of that material to the etch rate of tin oxide is greater than one, and wherein tin oxide is exposed to the same etch chemistry as the etched material at any time of the etching process. For example, tin oxide may be exposed when the etching begins, or it may become exposed during the course of etching. Etch selectivity of a selective etch of a material in a presence of tin oxide refers to a ratio of an etch rate of that material to an etch rate of tin oxide for a given chemistry. For example, carbon can be selectively etched in a presence of tin oxide using a oxygen-based etch chemistry with an etch selectivity of greater than 50.

In some embodiments a semiconductor substrate is provided, where the semiconductor substrate includes an exposed tin oxide layer and a layer of a second material, where the second material may be exposed or not exposed. Next tin oxide is selectively etched in a presence of the second material using one of the selective tin oxide etch chemistries described herein. The second material may be exposed prior to this etch or may become exposed during the course of tin oxide etching.

In some embodiments a semiconductor substrate is provided, where the semiconductor substrate includes an exposed layer of a first material and a layer of tin oxide, where the tin oxide may be exposed or not exposed. Next, the first material is selectively etched in a presence of the tin oxide using one of the selective chemistries described herein. The tin oxide may be exposed prior to this etch or may become exposed during the course of tin oxide etching.

Hydrogen-based etch. In some embodiments selective tin oxide etching is performed using a hydrogen-based etch. Hydrogen-based etch involves exposing tin oxide to a hydrogen-containing reactant (typically with plasma activation of the reactant) such that it converts tin oxide to a volatile tin hydride. SnH<sub>4</sub> has a boiling temperature of -52° C. and can be easily removed from the process chamber. Examples of hydrogen-containing reactants include H<sub>2</sub>, HBr, NH<sub>3</sub>, H<sub>2</sub>O, and hydrocarbons (such as CH<sub>4</sub>). Mixtures of hydrogen-containing reactants can also be used. Hydrogen-based etching involves forming a plasma in a process gas containing a hydrogen-containing reactant, and, optionally, an inert gas, and contacting the substrate with the

formed plasma. Examples of inert gases include nitrogen ( $N_2$ ), helium (He), argon (Ar), and neon (Ne), and xenon (Xe). In some embodiments  $H_2$  is the preferred hydrogen-containing reactant, and in some embodiments it is preferable to form plasma in a gas that contains at least 50%, such as at least 80%  $H_2$  by volume. In other embodiments HBr is used as the hydrogen-containing reactant. For example tin oxide can be selectively etched with a plasma formed in a process gas consisting essentially of HBr and an inert gas, such as in a mixture of HBr,  $N_2$  and argon. The hydrogen-based etch is typically conducted with a process gas that does not include oxygen-containing and fluorine-containing species. In some embodiments, the process gas consists essentially of one or more hydrogen-containing reactants and, optionally, an inert gas.

Hydrogen-based etch can selectively remove tin oxide in a presence of the following materials: silicon-containing compounds, such as  $SiO_2$ , SiN, SiC, SiOC, SiCN, SiON, SiCNO, spin on glass; metal oxides, such as titanium oxide, tungsten oxide, and zirconium oxide; metal nitrides, such as titanium nitride and tantalum nitride; metals, such as tungsten; photoresist and organic polymers. Further, hydrogen based etch can be used to selectively etch tin oxide in a presence of silicon oxide covered silicon. Silicon oxide often forms on silicon surfaces when silicon is exposed to atmosphere. Hydrogen-based etch can be also used to selectively etch tin oxide in a presence of elemental silicon (e.g., amorphous silicon), and carbon. Further, hydrogen-based etch can be used to selectively etch tin oxide in a presence of metal carbides, and materials that contain metal and carbon. For example, tin oxide can be selectively etched with a hydrogen-based etch in a presence of a tungsten carbon material (also referred to as tungsten-doped carbon). In some embodiments, tungsten carbon material includes between about 20-60 atomic % tungsten.

In some embodiments a semiconductor substrate is provided, where the semiconductor substrate includes an exposed tin oxide layer and a layer of any of these materials. Next, tin oxide is selectively etched in a presence of these materials. These materials may be exposed prior to this etch or may become exposed during the course of tin oxide etching.

The etch selectivity of the hydrogen-based etch in some embodiments is greater than 10, such as greater than 30, e.g., greater than 50, or greater than 80. The etch selectivity refers to the ratio of the etch rate of tin oxide to the etch rate of the other material for selected process conditions. In some examples, etch selectivity of 100 was achieved for etching tin oxide relative to  $SiO_2$  with the use of  $H_2$  plasma.

The tin oxide etching methods that utilize hydrogen plasma (referring to a plasma formed in a hydrogen-containing reactant) can be implemented in a variety of apparatuses under a wide range of process conditions. In one implementation the methods involve, providing a semiconductor substrate having an exposed layer of tin oxide to an etch chamber, and contacting the substrate with a plasma formed in a process gas comprising  $H_2$  (or another hydrogen-containing gas), and, optionally a carrier gas, such as helium or another inert gas. The term "etch chamber" or an "etching apparatus" refers to a chamber and an apparatus that are configured for etching. In some embodiments the "etch chamber" or the "etching apparatus" are exclusively configured for etching operations. In other embodiments the "etch chamber" or "etching apparatus" may be configured to perform other operations in addition to etching, such as, for example, deposition. For example, in some embodiments the etch chamber may also be used for ALD deposition.

In some embodiments the plasma used for in the hydrogen plasma etch is generated in the same process chamber that houses the semiconductor substrate. In other embodiments the plasma is generated remotely, and is introduced into the process chamber that houses the substrate through one or more inlets in the process chamber.

The etching is controlled such as to convert tin oxide to a volatile tin hydride. In one embodiment the  $H_2$  content in the process gas is at least 50% by volume, such as at least 80% by volume (can be up to and including 100%). In some embodiments, the process gas may further include a hydrocarbon, such as  $CH_4$ . In some embodiments, the process gas further includes  $Cl_2$ . For example, the process gas may consist essentially of  $H_2$  and an inert gas (e.g., He), or the process gas may consist essentially of  $H_2$ , inert gas and a hydrocarbon (e.g.,  $CH_4$ ). The etch is performed at a temperature of less than about  $100^\circ C.$ , measured near the substrate. The etch reaction, advantageously, generates only volatile materials, such as  $SnH_4$ , which can be easily removed from the etch process chamber by evacuation and/or purging. The etch process temperature is preferably selected to be less than about  $100^\circ C.$ , because higher temperatures can lead to decomposition of formed  $SnH_4$  and to formation of particles that can contaminate the process chamber and the substrate. The composition of the process gas and process conditions are selected such as to reduce or eliminate formation of particles during the etch. Significantly, the etch reaction does not require any significant sputtering component, and can be performed in an absence of external bias at the substrate, and in an absence of heavy ions (e.g., argon ions). Reducing sputtering component can be beneficial for increasing the etch selectivity relative to the second material on the substrate. Thus, in some embodiments etching is performed without providing an external bias to the substrate and/or involves using helium (a light gas) as the carrier gas, in order to reduce sputtering.

Plasma for the hydrogen plasma etch can be generated using a variety of frequencies (low and high). Examples of suitable frequencies include 400 KHz, 2 MHz, 13.56 MHz, 27 MHz or 2.45 GHz. Power used for plasma generation can range in some embodiments, from between about 50 W to 1,000 W corresponding to power density of between about  $0.0018$  and  $0.36 W/cm^2$ . The bias at the substrate is optional, and bias power can range from about 0 to 500 W. Suitable gas flow rates per showerhead (for processing one 300 mm wafer) are:

- i.  $H_2$ : 25 to 750 sccm;
- ii.  $Cl_2$ : 0 to 500 sccm (e.g., 5-200 sccm);
- iii. He: 0 to 500 sccm (e.g., 5-100 sccm); and
- iv.  $CH_4$ : 0 to 500 sccm (e.g., 5-100 sccm).

The etch process can be performed, in some embodiments, at a pressure of between about 1 to 175 mTorr.

In some specific embodiments the plasma is generated using high frequency generation (e.g., 13.56 MHz or 27 MHz), and it is provided using plasma power of between about 200 to 500 W corresponding to power density of  $0.07$  and  $0.18 W/cm^2$ . The power for the bias at the substrate is between about 0 and 200 W. Suitable gas flow rates per showerhead (for processing one 300 mm wafer) are:

- i.  $H_2$ : 100 to 300 sccm;
- ii.  $Cl_2$ : 0 to 200 sccm (e.g., 5-100 sccm);
- iii. He: 0 to 100 sccm (e.g., 5-50 sccm);
- iv.  $CH_4$ : 0 to 100 sccm (e.g., 5-50 sccm).

The etch process is performed in these embodiments at a pressure of between about 1 to 30 mTorr.

It was discovered that the selectivity of the hydrogen-based etch can be significantly increased by using carbon-

containing reactants in the process gas that form a carbon-containing polymer (e.g.  $\text{CH}_x$  polymer) on the surface of the substrate during the etch. In some embodiments, the process gas used in this embodiment includes  $\text{H}_2$  and a hydrocarbon (e.g., methane ( $\text{CH}_4$ )). The process gas typically also includes an inert gas. The ratio of  $\text{H}_2$  to hydrocarbon, in some embodiments is preferably at least 5, such as at least 10. In some embodiments the volume ratio of  $\text{H}_2$  to hydrocarbon is between about 5-500, such as about 10-300. In some embodiments selective etching of tin oxide in a presence of another material (or materials) includes exposing the substrate to a plasma formed in a process gas comprising  $\text{H}_2$  and a hydrocarbon (e.g.,  $\text{CH}_4$ ). In one implementation  $\text{H}_2$  is provided at a flow rate of between about 100-500 sccm, and hydrocarbon is provided at a flow rate of between about 1-20 sccm (such as between about 5-10 sccm). The process can be conducted using plasma power of between about 100-1,000 W, such as between about 200-500 W (for a single 300 mm wafer), corresponding to power densities of between about 0.14-1.3  $\text{W}/\text{cm}^2$ , such as 0.28-0.71  $\text{W}/\text{cm}^2$ . In some implementations, the etch is conducted using a substrate bias of between about 50-500 Vb, such as between about 100-200 Vb. The process is preferably performed at a temperature of less than about  $100^\circ\text{C}$ . In one specific example the following gases are provided:  $\text{H}_2$  at 100 sccm;  $\text{CH}_4$  at 5 sccm, and helium at 100 sccm. The plasma is formed in the process gas using a power of 300 W, and the substrate bias of 100 Vb at 25% duty cycle is used. The process is performed at  $30^\circ\text{C}$ . and at a pressure of 5 mTorr. The formation of carbon-containing polymer on a substrate as described herein can increase the etch selectivity of tin oxide relative to any of the materials listed herein. This effect is particularly useful when tin oxide is etched in a presence of photoresist, carbon, carbon-containing materials, and silicon (Si). For example when the etching is conducted in a presence of photoresist, the etch selectivity can be greater than 100, and in some cases is nearly infinite. The use of this highly selective etch allows the use of photoresist of smaller thickness to lower photolithographic exposure dose and/or to prevent photoresist line collapse due to high aspect ratio at small fine pitch. In the described method the  $\text{CH}_x$  polymer protects the photoresist from being etched. Further this etch can be used to improve the geometry of the photoresist layer. In some embodiments, the tin oxide on a semiconductor substrate is selectively etched using this etch in a presence of a photoresist disposed above the tin oxide layer, and in a presence of a material that underlies tin oxide, with an etch selectivity of at least 10 relative to both photoresist and the material that underlies tin oxide. In some embodiments the material that underlies tin oxide includes one or more of silicon (e.g., amorphous silicon), silicon-containing compound (e.g.,  $\text{SiO}_2$ , SiN, SiC, SiON, SiOC), carbon (e.g., amorphous carbon), and a carbon-containing compound (e.g., carbon tungsten).

In some embodiments, HBr is used as a hydrogen-containing reactant in the hydrogen-based etch. In one implementation, the etching method involves flowing HBr at a flow rate of 100-50 sccm, and an inert gas (e.g., helium) at a flow rate of 100-500 sccm and forming a plasma in this process gas using RF power of 100-500 W (per one 300 mm wafer) corresponding to power densities of 0.14-0.71  $\text{W}/\text{cm}^2$ . This etch can be conducted with or without a substrate bias. For example, substrate bias may be between 0-200 Vb, such as 50-200 Vb. The process can be performed at a temperature of less than  $100^\circ\text{C}$ . and a pressure of 5-50 mTorr.

Chlorine-based etch. In some embodiments selective tin oxide etching is performed using a chlorine-based etch. Chlorine-based etch involves exposing tin oxide to a chlorine-containing reactant (typically with plasma activation of the reactant) such that it converts tin oxide to a tin chloride.  $\text{SnCl}_4$  has a boiling point of  $114^\circ\text{C}$ . and can be removed from the process chambers. Examples of suitable chlorine-containing reactants include  $\text{Cl}_2$ , and  $\text{BCl}_3$ . Mixture of  $\text{Cl}_2$  and  $\text{BCl}_3$  is used in one embodiment. Chlorine-based etching involves, in one implementation, forming a plasma in a process gas containing a chlorine-containing reactant, and, optionally, an inert gas, and contacting the substrate with the formed plasma. Chlorine-based etch can selectively remove tin oxide in a presence of the following materials: silicon-containing compounds, such as  $\text{SiO}_2$ , SiN, SiC, SiOC, SiCN, SiON, SiCNO, spin on glass, carbon, and photoresist, although the selectivity for silicon-containing material is typically lower than with a hydrogen-based etch. In some embodiments a semiconductor substrate is provided, where the semiconductor substrate includes an exposed tin oxide layer and a layer of any of these materials. Next, tin oxide is selectively etched in a presence of these materials using the chlorine-based etch. These materials may be exposed prior to this etch or may become exposed during the course of tin oxide etching. In one implementation tin oxide is selectively etched in a presence of any of these materials using a  $\text{BCl}_3/\text{Cl}_2$  etch. In one implementation, the etching method involves flowing  $\text{BCl}_3$  at a flow rate of 5-100 sccm,  $\text{Cl}_2$  at a flow rate of 50-500 sccm and an inert gas (e.g., helium) at a flow rate of 100-500 sccm and forming a plasma in this process gas using RF power of 100-500 W (per one 300 mm wafer) corresponding to power densities of 0.14-0.71  $\text{W}/\text{cm}^2$ . This etch can be conducted with or without a substrate bias. For example, substrate bias may be between 0-100 Vb, such as 10-100 Vb. The process can be performed at a temperature of less than  $100^\circ\text{C}$ . and a pressure of 5-50 mTorr.

In some embodiments chlorine based etch is used to selectively etch certain metal oxides in a presence of tin oxide. For example titanium oxide can be selectively etched in a presence of tin oxide using chlorine-based etch. In some embodiments a semiconductor substrate is provided, where the semiconductor substrate includes an exposed titanium oxide layer and a layer of tin oxide. Next, titanium oxide is selectively etched in a presence of tin oxide using the chlorine-based etch chemistry. Tin oxide may be exposed prior to this etch or may become exposed during the course of tin oxide etching.

Fluorocarbon-based etch. In some embodiments silicon-containing compounds such as  $\text{SiO}_2$ , SiN, SiC, SiOC, SiCN, SiON, SiCNO, spin on glass are selectively etched in a presence of tin oxide using a fluorocarbon-based etch. Fluorocarbon-based etch involves exposing the silicon-containing compounds to plasma-activated fluorocarbons ( $\text{C}_x\text{F}_y$ ) such that they are converted to volatile compounds containing Si—F bonds. Examples of suitable fluorocarbon reactants include  $\text{CF}_4$ ,  $\text{C}_2\text{F}_6$  and the like. Fluorocarbon-based etching involves, in one implementation, forming a plasma in a process gas containing a fluorocarbon, and, optionally, an inert gas, and contacting the substrate with the formed plasma. Fluorocarbon etch can selectively remove silicon-containing compounds in a presence of tin oxide. In some embodiments a semiconductor substrate is provided, where the semiconductor substrate includes an exposed layer of a silicon-containing compound and a layer of tin oxide. Next, the substrate is contacted with a fluorocarbon plasma and the silicon-containing compound is selectively

etched in a presence of tin oxide. Tin oxide may be exposed prior to this etch or may become exposed during the course of etching. Fluorocarbon-based etch is a type of a fluorine-based etch.

Fluorine-based etch. In some embodiments elemental silicon and silicon-containing compounds such as SiO<sub>2</sub>, SiN, SiC, SiOC, SiCN, SiON, SiCNO, and spin on glass are selectively etched in a presence of tin oxide using a fluorine-based etch. Fluorine-based etch involves exposing the silicon-containing material to a fluorine-containing reagent (e.g., NF<sub>3</sub>, SF<sub>6</sub>, or a fluorocarbon), which is in some embodiments plasma-activated, and converting the silicon-containing material to a volatile silicon fluoride. Tin oxide, however, does not form a volatile fluoride and therefore is not substantially etched by this chemistry. In addition to silicon-containing materials, titanium oxide, tungsten, and tungsten carbon can be selectively etched in a presence of tin oxide using fluorine-based etches. Fluorine-based etching involves, in one implementation, forming a plasma in a process gas containing a fluorine-containing reactant (e.g., NF<sub>3</sub>), and, optionally, an inert gas, and contacting the substrate with the formed plasma. Fluorine-based etch can selectively remove silicon-containing compounds and elemental silicon in a presence of tin oxide. In some embodiments a semiconductor substrate is provided, where the semiconductor substrate includes an exposed layer of a silicon-containing compound and/or a layer of elemental silicon (Si) and a layer of tin oxide. Next, the substrate is contacted with a fluorine-containing reactant in a plasma and the silicon-containing compound and/or Si is selectively etched in a presence of tin oxide. Tin oxide may be exposed prior to this etch or may become exposed during the course of etching.

In one implementation silicon (Si) is selectively etched in a presence of tin oxide using a fluorine-based etch. In one implementation, this etching method involves flowing NF<sub>3</sub> at a flow rate of 5-100 sccm, Cl<sub>2</sub> at a flow rate of 50-500 sccm and an inert gas (e.g., nitrogen and/or helium) at a flow rate of 100-500 sccm and forming a plasma in this process gas using RF power of 100-1000 W (per one 300 mm wafer) corresponding to power densities of 0.14-1.4 W/cm<sup>2</sup>. This etch can be conducted with or without a substrate bias. For example, substrate bias may be between 0-100 Vb, such as 10-100 Vb. The process can be performed at a temperature of less than 100° C. and a pressure of 10-300 mTorr.

In some embodiments a semiconductor substrate is provided, where the semiconductor substrate includes an exposed layer of a titanium oxide, tungsten, and/or tungsten carbon; and a layer of tin oxide. Next, the substrate is contacted with a fluorine-containing reactant in a plasma and titanium oxide, tungsten, and/or tungsten carbon is selectively etched in a presence of tin oxide. Tin oxide may be exposed prior to this etch or may become exposed during the course of etching.

In one implementation titanium oxide is selectively etched in a presence of tin oxide using a fluorine-based etch. In one implementation, this etching method involves flowing CF<sub>4</sub> at a flow rate of 5-500 sccm, CHF<sub>3</sub> at a flow rate of 0-500 sccm (e.g., 10-500 sccm) and an inert gas (e.g., argon) at a flow rate of 100-500 sccm and forming a plasma in this process gas using RF power of 500-1000 W (per one 300 mm wafer) corresponding to power densities of 0.71-1.4 W/cm<sup>2</sup>. This etch can be conducted with or without a substrate bias. For example, substrate bias may be between 0-300 Vb, such as 10-300 Vb. The process can be performed at a temperature of less than 100° C. and a pressure of 5-50 mTorr.

In one implementation tungsten carbon is selectively etched in a presence of tin oxide using a fluorine-based etch. In one implementation, this etching method involves flowing NF<sub>3</sub> at a flow rate of 5-100 sccm, Cl<sub>2</sub> at a flow rate of 5-500 sccm and an inert gas (e.g., argon and/or nitrogen) at a flow rate of 100-500 sccm and forming a plasma in this process gas using RF power of 100-1000 W (per one 300 mm wafer) corresponding to power densities of 0.14-1.4 W/cm<sup>2</sup>. This etch can be conducted with or without a substrate bias. For example, substrate bias may be between 0-100 Vb, such as 10-100 Vb. The process can be performed at a temperature of less than 100° C. and a pressure of 10-100 mTorr.

Oxygen-based etch. In some embodiments one or more materials selected from the group consisting of elemental carbon, carbon-containing compounds, polymers, and photoresist is selectively etched in a presence of tin oxide using an oxygen-based etch. Oxygen-based etch involves exposing the materials listed above to an oxygen-containing reagent (e.g., O<sub>2</sub>, O<sub>3</sub>, SO<sub>2</sub>, or CO<sub>2</sub>), which is in some embodiments plasma-activated, and converting the material to a volatile product containing carbon-oxygen bond (e.g., CO or CO<sub>2</sub>). Oxygen-based etching involves, in one implementation, forming a plasma in a process gas containing an oxygen-containing reactant (e.g., O<sub>2</sub>), and, optionally, an inert gas, and contacting the substrate with the formed plasma. In other embodiments etching may occur in an absence of plasma. Oxygen-based etch can selectively remove carbon (e.g., amorphous or diamond-like carbon), carbon-containing compounds, and photoresist in a presence of tin oxide. In some embodiments a semiconductor substrate is provided, where the semiconductor substrate includes an exposed layer of one or more materials selected from the group consisting of carbon, a carbon-containing compound and a photoresist, and a layer of tin oxide. Next, the substrate is contacted with an oxygen-containing reactant (optionally activated in a plasma) to convert carbon-containing materials to volatile CO or CO<sub>2</sub> thereby selectively etching them in a presence of tin oxide. Tin oxide may be exposed prior to this etch or may become exposed during the course of etching.

Deposition of materials. Materials that are referenced herein can be deposited using a variety of deposition methods, such as CVD (which includes PECVD), ALD (which includes PEALD), PVD (e.g., for deposition of metals and metal oxides), spin-on methods (e.g., for deposition of carbon, and some dielectrics). When conformal deposition is needed, ALD methods are typically preferred.

SiO<sub>2</sub>, SiC, SiN, SiOC, SiNO, SiCNO, and SiCN materials can be deposited using a variety of methods, such as CVD, PECVD and ALD. The deposition can include a reaction between a silicon-containing precursor and a reactant (e.g., an oxygen-containing reactant, a nitrogen-containing reactant, or a carbon-containing reactant). A variety of silicon-containing precursors can be used for deposition of these materials, including silane, tetraalkylsilanes, trialkylsilanes, tetraethylorthosilicate (TEOS), etc. For example, SiO<sub>2</sub> may be deposited using TEOS or silane as the silicon-containing precursor.

Carbon can be deposited by a CVD or PECVD method by using, for example, a hydrocarbon precursor (e.g., CH<sub>4</sub>). In other implementations carbon may be deposited by spin-on methods or by PVD. Photoresist and organic polymers can be deposited, for example, by spin on methods.

The tin oxide layer is deposited by any suitable method such as by CVD (including PECVD), ALD (including PEALD), sputtering, etc. In some embodiments it is pref-

erable to deposit the SnO<sub>2</sub> film conformally, such that it follows the surface of the substrate, including the surfaces of any protrusions and recessed features on the substrate. One of the suitable deposition methods of conformal SnO<sub>2</sub> film is ALD. Thermal or plasma enhanced ALD can be used. In a typical thermal ALD method, the substrate is provided to an ALD process chamber and is sequentially exposed to a tin-containing precursor, and an oxygen-containing reactant, where the tin-containing precursor and the oxygen containing reactant are allowed to react on the surface of the substrate to form SnO<sub>2</sub>. The ALD process chamber is typically purged with an inert gas after the substrate is exposed to the tin-containing precursor, and before the oxygen-containing reactant is admitted to the process chamber to prevent reaction in the bulk of the process chamber. Further, the ALD process chamber is typically purged with an inert gas after the substrate has been treated with the oxygen-containing reactant. The sequential exposure is repeated for several cycles, e.g., between about 10-100 cycles can be performed until the tin oxide layer having a desired thickness is deposited. Examples of suitable tin-containing precursors include halogenated tin-containing precursors (such as SnCl<sub>4</sub>, and SnBr<sub>4</sub>), and non-halogenated tin-containing precursors, such as organotin compounds, which include alkyl substituted tin amides and the like. Specific examples of alkyl substituted tin amides that are suitable for ALD are tetrakis(dimethylamino) tin, tetrakis(ethylmethylamino) tin, N<sup>2</sup>,N<sup>3</sup>-di-tert-butyl-butane-2,3-diamino-tin(II) and (1,3-bis(1,1-dimethylethyl)-4,5-dimethyl-(4R,5R)-1,3,2-diazastannolidin-2-ylidene. Oxygen-containing reactants include without limitation oxygen, ozone, water, hydrogen peroxide, and NO. Mixtures of oxygen-containing reactants can also be used. The deposition conditions will vary depending on the choice of ALD reactants, where more reactive precursors will generally react at lower temperatures than less reactive precursors. The processes typically will be carried out at a temperature of between about 20-500° C., and at a sub-atmospheric pressure. The temperature and pressure are selected such that the reactants remain in the gaseous form in the process chamber to avoid condensation. Each reactant is provided to the process chamber in a gaseous form either alone or mixed with a carrier gas, such as argon, helium, or nitrogen. The flow rates of these mixtures will depend on the size of the process chamber, and are in some embodiments between about 10-10,000 sccm.

In one example the ALD process includes sequentially and alternately exposing the substrate in an ALD vacuum chamber to SnCl<sub>4</sub> (the tin-containing precursor) and deionized water (the oxygen-containing reactant) at a temperature of 200-400° C. In a specific example of an ALD cycle, a mixture of SnCl<sub>4</sub> vapor with N<sub>2</sub> carrier gas is introduced into the ALD process chamber for 0.5 seconds, and is then exposed to the substrate for 3 seconds. Next the ALD process chamber is purged with N<sub>2</sub> for 10 seconds to remove SnCl<sub>4</sub> from the bulk of the process chamber, and a mixture of H<sub>2</sub>O vapor with N<sub>2</sub> carrier gas is flowed into the process chamber for 1 second and is exposed to the substrate for 3 seconds. Next, the ALD process chamber is purged with N<sub>2</sub> and the cycle is repeated. The ALD process is performed at subatmospheric pressure (e.g., 0.4 Torr) and at a temperature of 200-400° C.

While the use of halogenated tin precursors in ALD is suitable in many embodiments, in some embodiments it is more preferable to use non-halogenated organotin precursors to avoid corrosion problems that may occur with the use of halogenated precursors such as SnCl<sub>4</sub>. Examples of

suitable non-halogenated organotin precursors include alkylaminotin (alkylated tin amide) precursors, such as tetrakis(dimethylamino) tin. In one example of an ALD process the substrate is sequentially exposed in an ALD chamber to tetrakis(dimethylamino) tin and H<sub>2</sub>O<sub>2</sub> at a temperature of between about 50-300° C. Advantageously, the use of this precursor allows deposition of SnO<sub>2</sub> films at low temperatures of 100° C. or less. For example, SnO<sub>2</sub> films can be deposited at 50° C. without the use of plasma to enhance reaction rate.

In some embodiments, SnO<sub>2</sub> films are deposited by PEALD. The same types of tin-containing precursors and oxygen-containing reactants as described above for thermal ALD can be used. In PEALD the ALD apparatus is equipped with a system for generating plasma in the process chamber, and for treating the substrate with the plasma. In a typical PEALD process sequence, the substrate is provided to the PEALD process chamber and is exposed to the tin-containing precursor which adsorbs on the surface of the substrate. The process chamber is purged with an inert gas (e.g., argon or helium) to remove the precursor from the process chamber, and the substrate is exposed to an oxygen-containing reactant which is introduced into the process chamber. Concurrently with the introduction of the oxygen-containing reactant or after a delay, plasma is formed in the process chamber. The plasma facilitates the reaction between the tin-containing precursor and the oxygen-containing reactant on the surface of the substrate that results in formation of tin oxide. Next, the process chamber is purged with an inert gas, and the cycle comprising tin precursor dosing, purging, oxygen-containing reactant dosing, plasma treatment, and second purging is repeated as many times as necessary to form a tin oxide film of desired thickness.

Tin Oxide as a Spacer

In some embodiments tin oxide layers are used as spacers. The use of tin oxide spacers is illustrated with reference to FIGS. 1A-1F, which provide schematic cross-sectional views of a semiconductor substrate at different stages of processing. FIG. 2 provides a process flow diagram for an embodiment of these methods.

Referring to FIG. 2, the process starts in **201**, by providing a substrate having a plurality of protruding features. An illustrative substrate is shown in FIG. 1A, which shows two mandrels **101** residing on an etch stop layer (ESL) **103**. The distance **d1** between the neighboring mandrels is, in some embodiments, between about 10-100 nm. In some embodiments relatively larger distances of about 40-100 nm are used. In other applications, the distance between closest mandrels is between about 10-30 nm. The distance between the centers of closest mandrels, **d2**, which is also referred to as pitch, is, in some embodiments, between about 30-130 nm. In some embodiments, the pitch is between about 80-130 nm. In other embodiments, the pitch is between about 30-40 nm. The height of the mandrels **d3** is typically between about 20-200 nm, such as between about 50-100 nm.

The materials of the mandrel and of the ESL are selected such as to allow subsequent selective etching of the mandrel material in the presence of exposed tin oxide, and selective etching of the ESL material in the presence of exposed tin oxide. Thus, the ratio of the etch rate of the ESL material to the etch rate of tin oxide is greater than 1, more preferably greater than about 1.5, such as greater than about 2 for a first etch chemistry. Similarly, the ratio of the etch rate of the mandrel material to the etch rate of tin oxide is greater than 1, more preferably greater than about 1.5, such as greater than about 2 for a second etch chemistry.

In some embodiments the ESL material is a silicon-containing compound (e.g., SiO<sub>2</sub>), or a metal oxide (e.g., titanium oxide, zirconium oxide, tungsten oxide). The mandrel material may include silicon-containing compound (e.g., SiO<sub>2</sub>, SiN, or SiC), a carbon-containing compound (e.g., amorphous carbon, diamond-like carbon or photoresist), amorphous silicon (doped or undoped) and a metal oxide (TaO, TiO, WO, ZrO, HfO). In some embodiments the outer material of the mandrel may be different from the mandrel core. For example, in some embodiments the mandrel is made of amorphous silicon which is covered with silicon oxide (e.g., with a spontaneously formed layer of thermal oxide). The ESL layer and the mandrels can be formed by one or more of physical vapor deposition (PVD), chemical vapor deposition (CVD), ALD (without plasma or by PEALD) or plasma enhanced chemical vapor deposition (PECVD) and the pattern of the mandrels can be defined using photolithographic techniques. Examples of suitable ESL/mandrel combination include: (i) a silicon oxide ESL and a silicon oxide covered silicon mandrel; (ii) a silicon oxide ESL and a carbon-containing mandrel; (iii) a silicon oxide ESL and a metal oxide mandrel; (iv) a metal oxide ESL and a silicon oxide covered silicon mandrel; (v) a metal oxide ESL and a carbon-containing mandrel.

Referring again to the substrate shown in FIG. 1A, the ESL layer **103** resides over and in contact with the target layer **105**. The target layer **105** is the layer that needs to be patterned. The target layer **105** may be a semiconductor, dielectric or other layer and may be made of silicon (Si), silicon oxide (SiO<sub>2</sub>), silicon nitride (SiN), or titanium nitride (TiN), for example. In some embodiments the target layer is referred to as a hardmask layer and includes metal nitride, such as titanium nitride. The target layer **105** may be deposited by ALD (without plasma or by PEALD), CVD, or other suitable deposition technique.

The target layer **105** resides over and in contact with layer **107**, which is in some embodiments a BEOL layer, that includes a plurality of metal lines embedded into a layer of dielectric material.

Referring again to FIG. 2, the process follows in **203** by depositing a tin oxide layer over both the horizontal surfaces and sidewalls of the protruding features. Referring to the structure shown in FIG. 1B, the tin oxide layer **109** is deposited over the ESL **103**, and over the mandrels **101**, including the sidewalls of the mandrels. The tin oxide layer is deposited by any suitable method such as by CVD (including PECVD), ALD (including PEALD), sputtering, etc. In some embodiments it is preferable to deposit the tin oxide film conformally, such that it follows the surface of the layer **103** and the mandrels **101**, as shown in FIG. 1B. In some embodiments the tin oxide layer is deposited conformally to a thickness of between about 5-30 nm, such as between about 10-20 nm. One of the suitable deposition methods of conformal tin oxide film is ALD. Thermal or plasma enhanced ALD can be used.

Referring to the process diagram of FIG. 2, after the tin oxide layer has been deposited, the process follows in **205** by completely removing the tin oxide from the horizontal surfaces, without completely removing the tin oxide layer from the sidewalls of the protruding features using hydrogen-based etch or a chlorine-based etch. If the mandrels have silicon-containing compounds or metal oxides as the outer layer a hydrogen-based etch can be used. If the outer layer of the mandrels is a carbon layer, chlorine-based etch can be used. The etch chemistry utilized in this step should be preferably selective to both the ESL material and to the material of the outer layer of the mandrel, i.e., the etch rate

of tin oxide for this etch chemistry should be greater than the etch rate of the outer mandrel material and greater than the etch rate of the ESL material. Removal of tin oxide from horizontal surfaces is illustrated by FIG. 1C. The tin oxide layer **109** is etched from the horizontal surfaces over ESL **103** and over mandrels **101**, without being fully etched from positions that adhere to the sidewalls of mandrels **101**. This etch exposes the layer **103** everywhere with the exception of locations near the sidewalls of the mandrels **101**. Further, this etch exposes the top portions of the mandrels. The resulting structure is shown in FIG. 1C. Preferably after this etch at least 50%, such as at least 80% or at least 90% of the initial height of the tin oxide layer at the sidewall is preserved. In one example tin oxide is selectively etched from a silicon oxide covered mandrel by a hydrogen-based etch (e.g., H<sub>2</sub> plasma etch) such that the outer material of the mandrel (SiO<sub>2</sub>) is exposed. Hydrogen-based etch is selective to SiO<sub>2</sub>. In another example tin oxide is selectively etched from a carbon-containing (e.g., carbon) mandrel by a chlorine-based etch (e.g., BCl<sub>3</sub>/Cl<sub>2</sub> plasma etch) such that the carbon-containing material of the mandrel is exposed. Such etch is selective to carbon-containing materials. In another example tin oxide is selectively etched from a metal oxide (e.g., titanium oxide) mandrel by a hydrogen-based etch (e.g., H<sub>2</sub> plasma etch) such that mandrel material (metal oxide) is exposed. This etch is selective to oxides of metals that do not form volatile hydrides, such as titanium oxide.

In some embodiments removal of the tin oxide layer from horizontal portions of the substrate involves using two steps with two different chemistries. In a first step, referred to as the main etch, the bulk of the tin oxide layer is removed from horizontal surfaces typically without fully exposing the underlying layers of mandrel and ESL materials. Etch chemistry of the main etch, therefore, in some embodiments, does not need to be selective. In some embodiments the main etch is performed by treating the substrate with a chlorine-based chemistry (e.g., BCl<sub>3</sub>/Cl<sub>2</sub> plasma etch). After the main etch etches through the SnO film or shortly before, the etching chemistry is switched to an over etch chemistry. The endpoint for the main etch can be detected by using an optical probe, which will signal when the mandrel material or ESL material becomes exposed. Selective over etch chemistry is used to remove leftover tin oxide film without substantially etching the materials of mandrel and ESL and has been described above.

Next, mandrels **101** are removed from the substrate leaving exposed tin oxide spacers **101** and an exposed layer ESL **103**, as shown in FIG. 1D. Removal of the mandrels is performed by exposing the substrate to an etch chemistry that selectively etches the mandrel material. Thus, the ratio of the etch rate of the mandrel material to the etch rate of the tin oxide in this step is greater than 1, and is more preferably greater than 1.5. Further, the etch chemistry used in this step should, in some embodiments, selectively etch the mandrel material relative to ESL material. A variety of etching methods can be used, and specific choice of chemistry depends on the material of the mandrel and on the material of the ESL layer. When the mandrel is made of amorphous silicon covered with silicon oxide, a fluorine-based chemistry (e.g., NF<sub>3</sub>) or may be used to remove the silicon mandrels **101** together with the SiO<sub>2</sub> layer covering them. This chemistry is selective to tin oxide.

Another option for silicon mandrel removal is the use of a plasma formed in a mixture of HBr and O<sub>2</sub>. In some embodiments, before the etch starts, the thin protective layer of silicon oxide is removed from the surface of silicon mandrels. This can be done by briefly exposing the substrate

to a plasma formed in a process gas comprising a fluorocarbon. After removal of the protective silicon oxide layer from the mandrels, the silicon is selectively etched. In some embodiments, it is preferable to use a relatively small RF bias, or no external bias at all for the substrate in this step. If no external bias is used, the self bias of the substrate (10-20 V) is sufficient. Under no bias or low bias conditions, the HBr/O<sub>2</sub> plasma will selectively etch silicon in the presence of tin oxide and silicon oxide. This etch can be performed in a presence of an ESL containing silicon-containing compounds.

When the mandrel is a carbon-containing material (e.g., carbon or photoresist) the mandrel can be selectively removed using an oxygen-based etch. This chemistry is selective to tin oxide and can be used in a presence of ESL composed of silicon-containing compounds, and metal oxide ESL.

When the mandrel is a metal oxide (e.g., titanium oxide, tungsten oxide, zirconium oxide, hafnium oxide, tantalum oxide) the substrate may be treated with a chlorine-based etch chemistry (e.g., BCl<sub>3</sub>/Cl<sub>2</sub> in a plasma) to selectively remove the mandrel relative to tin oxide. This chemistry can be used in a presence of an ESL containing silicon-containing compounds (e.g., SiO<sub>2</sub>, SiN, SiC).

Next, the exposed ESL film **103** is etched to expose the underlying target layer **105** at all positions that are not protected by the tin oxide spacers **109**. The resulting structure is shown in FIG. 1E. The etch chemistry that is used in this step selectively etches the ESL material in the presence of tin oxide. In other words, the ratio of the etch rate of the ESL material to the etch rate of tin oxide is greater than 1, and is more preferably greater than 1.5. The specific type of chemistry used in this step will depend on the type of the ESL material. When silicon-containing compounds (e.g., silicon oxide and silicon oxide based materials) are used, selective etching can be accomplished by exposing the substrate to a plasma formed in a process gas comprising a fluorocarbon. For example, the ESL film can be etched by a plasma formed in a process gas comprising one or more of CF<sub>4</sub>, C<sub>2</sub>F<sub>6</sub>, and C<sub>3</sub>F<sub>8</sub>. When the ESL is a metal oxide layer (e.g., titanium oxide, tungsten oxide, or zirconium oxide), it can be etched selectively in a presence of tin oxide using a chlorine-based etch chemistry (e.g., BCl<sub>3</sub>/Cl<sub>2</sub> in a plasma).

In the next step, the target layer **105** is etched at all positions that are not protected by the ESL film **103**, to expose the underlying layer **107**. The tin oxide spacers **109** are also removed in this etching step providing a patterned structure shown in FIG. 6. In some embodiments, the etch chemistry used in this step is selected to remove both the target material and the tin oxide spacer material. In other embodiments, two different etching steps with different chemistries can be used to pattern the target layer **105** and to remove tin oxide spacers **109** respectively. A number of etching chemistries can be used depending on the chemistry of the target layer. In one embodiment the target layer **105** is a metal nitride layer (e.g., a TiN) layer. In this embodiment the metal nitride layer may be etched, and the tin oxide spacers can be removed using a single etch chemistry by exposing the substrate to a plasma formed in a process gas comprising Cl<sub>2</sub> and a hydrocarbon (e.g., CH<sub>4</sub>). Generally, tin oxide spacers can be removed using any of tin oxide etching methods described above.

One of the problems encountered during formation of spacers is the footing of the spacer, which is the difference between the width of the spacer at the bottom and the width of the spacer at the top. Ideally, the spacer should be straight. Tin oxide spacers have been compared to titanium oxide

spacers experimentally. It was shown that with the use of H<sub>2</sub> plasma etch on tin oxide spacers, the footing can be significantly reduced to less than 1 nm. Titanium oxide, however, cannot be etched by H<sub>2</sub> plasma at all. When titanium oxide spacer was etched with an HBr/N<sub>2</sub>/argon plasma its footing was reduced only to 2.4 nm with the cost of greater spacer height and CD loss.

Further the etch selectivity of ALD-deposited titanium oxide to thermal silicon oxide (TOX) was demonstrated to be lower than the etch selectivity of ALD-deposited tin oxide to TOX for the HBr/N<sub>2</sub>/argon plasma etch. Specifically, with this chemistry titanium oxide was etched in a presence of TOX with a selectivity of about 10:1, whereas tin oxide was etched with a selectivity of greater than 100:1. With H<sub>2</sub> plasma titanium oxide was not etched at all, whereas tin oxide was etched in a presence of TOX with a selectivity of greater than 100:1. With BCl<sub>3</sub>/Cl<sub>2</sub>/He plasma titanium oxide was etched with a selectivity of about 5:1 (titanium oxide to TOX) whereas tin oxide was etched with a selectivity of about 4:1 (tin oxide to TOX). Hydrogen-based etch chemistries (both H<sub>2</sub>-based and HBr-based) provide very high etch selectivities to silicon oxide of greater than 50:1 and greater than 80:1 that cannot be achieved with titanium oxide.

In some embodiments, the methods described herein with reference to FIGS. 1A-1F and 2 are modified and involve the use of a passivation layer over tin oxide layer at the sidewalls of the mandrels. The purpose of the passivation layer is to minimize etching of tin oxide at the sidewalls during the step of tin oxide removal from horizontal surfaces. In an absence of the passivation layer, the tin oxide at the sidewalls may be inconsistently etched in a lateral direction, which may lead to spacer critical dimension (CD) variation. The use of a passivation layer can prevent or minimize this lateral etch and result in a more consistent distance between spacers. In addition, the use of a passivation layer can prevent the erosion of top corners of the spacers thereby leading to spacers with more rectangular shapes. Further, the use of a passivation layer at the sidewalls allows for more facile etch of the bottom slope or footing of the tin oxide layer as there would be more available etching species (e.g., ions in a plasma) being driven downward by a bias at the substrate. The passivation layer may eventually be consumed partially or completely in subsequent etching steps so that the spacer CD can be maintained.

The material of the passivation layer is selected such that it is more resistant to a particular etch chemistry that is being used for the removal of tin oxide from horizontal surfaces. In some embodiments, the passivation material is a silicon-containing compound such as SiO<sub>2</sub>, SiN, or SiC, which can be deposited, for example by PECVD. In other embodiments the passivation material is carbon (e.g., deposited using a hydrocarbon precursor), as described herein. In other embodiments, the passivation material is a tin-containing compound, such as tin nitride (SnN), tin bromide (SnBr), or tin fluoride (SnF). In some embodiments these compounds are formed by converting an outer portion of tin oxide to the tin-containing passivation material. For example, tin oxide can be converted to tin nitride by exposing the substrate to a nitrogen-containing compound in a plasma (e.g., N<sub>2</sub> plasma). Tin bromide may be formed by exposing the substrate to a bromine-containing compound (e.g. HBr). Tin fluoride may be formed by exposing the substrate to a fluorine-containing compound in a plasma (e.g., NF<sub>3</sub> plasma or fluorocarbon plasma). The conditions during SnBr and SnF deposition are adjusted such as to minimize etching. For



example, the reaction may be carried out without biasing the substrate or with low bias to minimize removal of SnBr and SnF. The passivation layer is typically formed to a thickness of about 1-5 nm.

FIGS. 3A-3E provide schematic cross-sectional view of a portion of the substrate during processing using passivation layer. FIG. 4 provides a process flow diagram for such process. Referring to FIG. 4, the process starts in 4401 by providing a substrate having a plurality of protruding features and proceeds in 4403 by depositing tin oxide on sidewalls and horizontal surfaces of the protruding features, in the same way as it was described with reference to FIGS. 1A and 1B. The substrate shown in FIG. 1B is also illustrated in FIG. 3A, where the target layer is layer 301, the ESL is 303, the mandrel is 305, and the tin oxide layer is 307. The materials of the layers generally may be the same as in the embodiment described with reference to FIGS. 1A-1F. In the embodiment illustrated in FIG. 3A the mandrel 305 is a silicon (Si) mandrel having an outer layer of silicon oxide (SiO<sub>2</sub>) 302, but it is understood that the described process sequence can be used with a variety of mandrel materials including carbon-containing mandrels and metal oxide mandrels. Referring to FIG. 4, after the tin oxide layer has been deposited, the process follows in 4405 by forming a passivation layer over the tin oxide layer at the sidewalls of the protruding features. The resulting structure is shown in FIG. 3C, which shows the passivation layer 309 on the sidewalls of the protruding feature. In the depicted embodiment the passivation layer is not present on the horizontal surfaces.

Such passivation layer can be formed in some embodiments by first (a) conformally depositing the passivation material (e.g., silicon oxide, silicon nitride, silicon carbide, or carbon) over both the sidewalls and the horizontal surfaces of the mandrel and then (b) completely removing the passivation layer from horizontal surfaces without completely removing the passivation layer from the sidewalls (e.g., such that at least 50, or at least 80% of the passivation layer material at the sidewall remains after etch).

When the passivation material is a silicon-containing compound, it can be etched from the horizontal surfaces using a fluorocarbon-based etch selectively to tin oxide. When the passivation material is a carbon-containing material it can be removed from horizontal surfaces using an oxygen-based etch selectively to tin oxide, or using a short exposure to a plasma formed in a hydrogen-containing gas (e.g. H<sub>2</sub>). Tin-containing passivation materials, in some embodiments are removed from horizontal surfaces using the same chemistry as used for tin oxide etching, with the use of a sufficient bias at the substrate that facilitates removal of material from horizontal surfaces. For example, the process may start with a plasma etch with a first bias to remove tin-containing passivation material from the horizontal surfaces and then the bias may be reduced or turned off as the process transfers to main tin oxide etch. In some embodiments a chlorine-based chemistry (e.g., BCl<sub>3</sub>/Cl<sub>2</sub> plasma) is used during etching of passivation material and tin oxide from the horizontal surfaces.

Next, referring to operation 4407 the process follows by completely removing tin oxide from the horizontal surfaces of the mandrel without completely removing the tin oxide at the sidewalls of the mandrel. This etch can be performed using any of the suitable tin oxide etch chemistries described herein, such as using a hydrogen-based etch (e.g., H<sub>2</sub> plasma), a chlorine-based etch (e.g., Cl<sub>2</sub> and/or BCl<sub>3</sub> in a plasma), HBr plasma etch or any combination of these etches. In the embodiment depicted in FIGS. 3D and 3E this

etch is performed in two steps. In a first step, the bulk of the tin oxide is etched from horizontal surfaces using a chlorine-based etch (e.g., BCl<sub>3</sub> and Cl<sub>2</sub> in a plasma) to provide a structure shown in FIG. 3C, where the structure has an exposed silicon oxide outer mandrel material at the top of the mandrel and an excess of tin oxide at the bottom corners of the mandrel. Next, the excess tin oxide is etched with a hydrogen-based overetch chemistry (e.g., H<sub>2</sub> in a plasma) providing a structure shown in FIG. 3D. Next the mandrel material is selectively etched and removed, as was previously described with reference to FIGS. 1A-1F, leaving the spacers 307. In the depicted embodiment the mandrel etch chemistry also removes the passivation layer 309, leading to a structure shown in FIG. 3E. Subsequent processing of the ESL can follow as was previously described with reference to FIGS. 1D-1F.

In one more specific example, layer 301 is TiN, the ESL 303 is a silicon oxide layer; the mandrel 305 is silicon (Si) covered with silicon oxide outer layer 302, and layer 307 is tin oxide. In reference to this example, the processing method includes: providing a substrate having a silicon oxide layer, and a plurality of silicon protrusions, where the silicon protrusions are covered with native silicon oxide, followed by depositing a tin oxide layer conformally over the substrate (e.g., by ALD) and forming a silicon oxide passivation layer (e.g., 1-2 nm thick) only over tin oxide on the sidewalls of the protruding features. After the passivation layer was formed, the method follows by etching tin oxide from horizontal surfaces without completely removing tin oxide residing at the sidewalls of the protruding features. In this example, the etching is conducted using a main (bulk) etch (e.g., Cl<sub>2</sub>/BCl<sub>3</sub> plasma etch) followed by overetch, where the overetch may be, for example a hydrogen plasma etch that is used to reduce footing. After etching the method continues by removing the silicon mandrels without removing the tin oxide spacers. It is noted that the silicon oxide passivation layer on the sidewalls can be formed by first conformally depositing silicon oxide over tin oxide (e.g., by PECVD, or ALD), and then selectively etching silicon oxide from horizontal surfaces (e.g., by fluorocarbon plasma). This sequence was experimentally tested using BCl<sub>3</sub>/Cl<sub>2</sub> plasma main etch followed by H<sub>2</sub> plasma overetch for tin oxide removal from horizontal surfaces. In this experimentally tested example, after the main etch, the critical dimension loss was zero nm; the footing was about 6 nm, and the amount of etch into silicon oxide ESL is zero nm. After the overetch, the critical dimension loss, the footing, and the amount of etch into silicon oxide ESL were all zero nm.

In another specific example, tin nitride formed from an outer portion of the tin oxide is used as a passivation material. In some embodiments, it is preferable to passivate the sidewalls of tin oxide using a tin nitride passivation layer during formation of tin oxide spacers, and thereby reduce the variation in the spacer. In some embodiments the method includes: (a) providing a substrate having a silicon oxide layer, and a plurality of silicon protrusions, where the silicon protrusions are covered with native silicon oxide; (b) depositing a tin oxide layer conformally over the substrate (e.g., by ALD); (c) forming a thin tin nitride passivation layer only over tin oxide on the sidewalls of the protruding features; (d) etching tin oxide from horizontal surfaces without completely removing tin oxide residing at the sidewalls of the protruding features (e.g., using a combination of a main (bulk) etch (e.g., Cl<sub>2</sub>/BCl<sub>3</sub> etch) and overetch, where the overetch may be, for example hydrogen plasma etch that is used to reduce footing); and (d) removing the silicon man-

drels without removing the tin oxide spacers. The tin nitride passivation layer on the sidewalls can be formed by first conformally forming the passivation layer over the entire tin oxide layer, followed by selectively removing tin nitride from horizontal surfaces. In some embodiments tin nitride layer is formed by treating the exposed tin oxide layer with a nitrogen-containing plasma. For example, the plasma may be formed in a nitrogen-containing gas, such as  $N_2$  or  $NH_3$ . The plasma may be direct (formed in the same chamber compartment that houses the substrate) or remote (formed in a different chamber or chamber compartment and fed to the compartment housing the substrate). In some embodiments this nitridation treatment is performed in the same process chamber that is used for tin oxide layer deposition. In other embodiments, nitridation is performed in a different chamber. In some embodiments, the nitridizing plasma treatment is performed for less than about 5 seconds. Another method for forming a conformal layer of tin nitride is deposition of tin nitride over the conformal tin oxide layer. Tin nitride can be deposited, for example, by ALD or CVD. In some embodiments, ALD deposition involves contacting the substrate with a tin-containing precursor and forming a tin-containing layer on the surface of the substrate, followed by treatment with a nitrogen-containing plasma, where the process is repeated as many times as necessary to build a passivation layer of desired thickness. After the conformal tin nitride layer has been formed, tin nitride is etched from horizontal surfaces leaving tin nitride only on the sidewalls. In some embodiments, the chemistry of this etch is the same as the chemistry of the main etch, but it is carried out using substrate bias, such that it is more vertically anisotropic than the main etch. For example, tin nitride can be removed from horizontal surfaces using  $Cl_2/BCl_3$  plasma etch with substrate bias. Next, the  $Cl_2/BCl_3$  main etch follows (e.g., with no substrate bias or with lower bias than that used during tin nitride removal from horizontal surfaces), which is then followed by  $H_2$  overetch. Tin nitride provides an excellent protection to tin oxide at the sidewalls during the main etch process. The use of tin nitride as a passivation layer has been experimentally tested and it was confirmed that the thickness of tin oxide on the sidewalls of mandrels is greater in those cases, where tin nitride passivation layer was used, than in identical structures processed without tin oxide nitridation.

**Hardmask Applications**

In some embodiments, tin oxide films are used as hardmasks. Tin oxide hardmasks can be patterned such as to form a substrate having recessed features, where there is an exposed material at the bottoms of the recessed features. The substrate then can be processed in a presence of the tin oxide hardmask. In some embodiments processing involves etching the material exposed at the bottoms of the recessed features. In other embodiments, processing may involve depositing a material into the recessed features. In other embodiments, processing may involve chemically modifying the material exposed at the bottoms of the recessed features.

Patterned tin oxide layers can be formed using a variety of methods. In one embodiment patterned tin oxide film is formed using photolithographic patterning. The method involves, in one embodiment, providing a substrate having a blanket tin oxide layer formed on a substrate and forming a patterned photoresist layer over the blanket tin oxide layer. The patterned photoresist layer over the tin oxide layer in some embodiments is formed directly on top of and in contact with the tin oxide layer. In other embodiments, there may be one or more intermediate hardmask layers between the layer of tin oxide and photoresist. After the photoresist

layer has been deposited and patterned using standard photolithographic techniques, the pattern from the photoresist is transferred onto the tin oxide layer, i.e. the exposed tin oxide layer is etched. In some embodiments the tin oxide layer is etched in a presence of exposed photoresist using a selective etch, such as a hydrogen-based etch (e.g.,  $H_2$  in a plasma). When intermediate hardmasks are present between the layer of tin oxide and photoresist, the pattern from the photoresist is first transferred to these intermediate hardmasks (e.g., mask containing a silicon-containing compound such as spin-on glass, or a carbon mask) and then to tin oxide. In some embodiments the tin oxide layer is etched in a presence of another intermediate hardmask material (e.g., a silicon-containing compound or carbon) using a suitable selective chemistry, such as hydrogen-based etch and/or chlorine-based etch.

FIGS. 5A-5C illustrate schematic cross-sectional views of a substrate undergoing processing with a tin oxide mask. FIG. 6 provides a process flow diagram for processing the substrate with a tin oxide hardmask. In operation 601, a substrate having patterned tin oxide layer is provided. The tin oxide layer may be patterned using photolithographic techniques as described above or using the process sequence that is used to form tin oxide spacers, that was described with reference to FIG. 1A-1D. An example of such substrate is shown in FIG. 5A, where the substrate includes a sublayer 51, and a layer 53, which resides between the sublayer 51 and the patterned tin oxide layer 55. The exposed portion of the substrate includes recessed features formed in the tin oxide layer 55. The material of layer 53 is exposed at the bottoms of the recessed features. While in the depicted embodiment there is no additional material on the top of patterned tin oxide layer 55, in other embodiments there may be photoresist or material from intermediate hardmasks present on top of tin oxide 55.

Next, in operation 603, the substrate is processed in a presence of the tin oxide layer 55. Processing may involve, for example, etching of the exposed material 53, deposition of material into the recessed features, or chemical modification of the exposed material 53. Etching of material 53 is illustrated in FIG. 5B, where recessed features defined by the pattern of the tin oxide layer 55 are formed in layer 53. A variety of selective etch chemistries can be used for etching the material of layer 53 in a presence of tin oxide 55. For example, when layer 53 is a silicon-containing material, it may be selectively etched in a presence of tin oxide using a fluorine-based chemistry. For example silicon-containing compounds, such as silicon oxide, silicon nitride and silicon carbide can be etched using a fluorocarbon plasma chemistry. When layer 53 is a carbon-containing layer (e.g., amorphous carbon), it may be selectively etched using an oxygen-based chemistry, as described herein. When layer 53 is a metal oxide layer (e.g., titanium oxide, zirconium oxide, tantalum oxide, hafnium oxide), it may be selectively etched in a presence of tin oxide using a chlorine-based chemistry, as described herein (e.g.,  $BCl_3/Cl_2$  in a plasma). The material of the sublayer 51 is different from the material of layer 51, and layer 51 is not substantially etched during the etching of layer 53. The resulting structure, shown in FIG. 5B has recessed features formed in layer 55 and 53 and an exposed material of sublayer 51 at the bottoms of the recessed features.

Next, in operation 603 the tin oxide material 55 is removed providing a structure shown in FIG. 5C, where a patterned layer 53 resides over sublayer 51. In some embodiments, this sequence is further used to pattern sublayer 51, which is in some embodiments a SiN layer, a metal nitride

(e.g., TiN, or TaN), or metal layer. Removal of tin oxide is preferably performed using a chemistry that is selective to both the material of layer **53** and layer **51**. For example, when these materials are silicon-containing materials, carbon-containing materials, metal oxides, metal nitrides, or metals a selective hydrogen-based etch (e.g., H<sub>2</sub> plasma etch may be used). Further, in some embodiments when materials of layer **53** and **51** are silicon-containing materials or carbon-containing materials a chlorine-based etch (e.g., BCl<sub>3</sub>/Cl<sub>2</sub> in a plasma) may be employed.

In one specific example of a process flow that uses a tin oxide hardmask, the sublayer **51** is a SiN layer, or a metal layer, and layer **53** is silicon oxide. The process starts by providing a planar substrate having an exposed layer of silicon oxide over the SiN or metal layer **51**. Next, a blanket tin oxide layer is deposited over silicon oxide, and tin oxide is then patterned (e.g., using photolithographic patterning), leading to a structure shown in FIG. **5A**. Next, exposed silicon oxide is selectively etched relative to tin oxide, for example, using fluorocarbon plasma, leading to a structure shown to FIG. **5B**. Next, tin oxide is stripped (removed), for example, using a hydrogen plasma etch, leading to a structure shown in FIG. **5C**.

**Tin Oxide Middle Layer.** In another hardmask implementation, tin oxide is used as an intermediate hardmask (middle layer) for patterning of a carbon layer or another material. In one embodiment, a substrate is provided, where the substrate includes a patterned layer of tin oxide formed on a carbon-containing layer (e.g., on an amorphous carbon layer), wherein the substrate includes a plurality of recessed features having an exposed carbon-containing material at the bottoms of the recessed features. Next the exposed carbon-containing material is selectively etched in a presence of tin oxide to form recessed features in the carbon-containing layer. Suitable selective etch chemistries include hydrogen-based etch chemistry (e.g., H<sub>2</sub> in a plasma, and HBr in a plasma) and chlorine-based etch chemistry (e.g., BCl<sub>3</sub> and/or Cl<sub>2</sub> in a plasma). One suitable process sequence is illustrated by cross-sectional substrate views shown in FIGS. **5D-5G**. The substrate shown in FIG. **5D** includes a sublayer **51** (e.g., amorphous silicon or any of the target layers described herein), a blanket layer **53** of a carbon-containing material (e.g., amorphous carbon) residing over sublayer **51** and a blanket tin oxide layer **55** residing over carbon-containing layer **53**. The substrate further includes a patterned photoresist layer **57** over the tin oxide layer **55**, and an underlayer **56** between the photoresist **57** and the tin oxide layer **55**, where the underlayer may be, for example, spin on glass. The underlayer **56** is exposed at the bottoms of the recessed features formed in the patterned photoresist layer **57** on the surface of the substrate. The pattern of the photoresist is transferred to the underlayer **56**, by selectively etching the underlayer in a presence of photoresist, e.g., by a fluorocarbon-based plasma etch. The etch exposes the tin oxide layer **55** at the bottoms of the recessed features, as shown in FIG. **5E**. Next, tin oxide is patterned using an etch that is preferably selective to the underlayer material. For example, tin oxide may be etched using a hydrogen-based etch or a chlorine-based etch. In the resulting structure shown in FIG. **5F**, the pattern has been transferred from photoresist to the tin oxide layer and the carbon-containing layer **53** is exposed at the bottoms of recessed features. Next, the process follows by etching the exposed carbon-containing layer **53**. Preferably, a chemistry that is selective to tin oxide is used. For example, the exposed carbon-containing layer **53** may be etched by an oxygen-based etch (e.g., carbon can be etched by an plasma formed in an oxygen-

containing gas). The remaining photoresist may also be removed in this step. The structure obtained after this etch is shown in FIG. **5G**. The process may further follow by removal of tin oxide **55** and subsequent processing of the exposed sublayer **51**.

Another implementation of the middle layer embodiment is shown in FIGS. **5H-5K**. The sequence is similar to the one described with reference to FIGS. **5D-5G**, but is performed without an underlayer **56**. In this sequence the patterned photoresist **57** is formed directly on the tin oxide layer **55**, which is followed by tin oxide etch in a presence of photoresist (e.g., using a hydrogen-based etch (H<sub>2</sub> or HBr)) or a chlorine-based etch. The process then follows to transfer the pattern from the tin oxide middle layer **55** to the carbon-containing layer **53**, where the layer **53** may itself serve as a hardmask for patterning the underlying layer **51**. Next, the tin oxide **55** is selectively etched and removed in a presence of carbon-containing layer **53**, e.g., using a hydrogen-based etch chemistry (e.g., H<sub>2</sub> in a plasma). These middle layer sequences are suitable for EUV hardmask processing applications.

In another embodiment, a highly selective etch is used to transfer the photoresist pattern to the tin oxide layer. For example tin oxide can be selectively etched in a presence of overlying photoresist and an underlying material using a hydrogen-based etch chemistry, with an addition of a carbon-containing reactant, where the carbon containing reactant is used to form a carbon-containing polymer on the surface of the substrate and increase etch selectivity. For example plasma may be formed in a mixture of H<sub>2</sub>, hydrocarbon (e.g., CH<sub>4</sub>), and, optionally an inert gas, as described herein. This will be illustrated with reference to FIGS. **5H-5K**. In this example, as shown in FIG. **5H**, a patterned layer of photoresist **57** is formed over the tin oxide layer **55** (e.g., 9-12 nm thick). The layer of material directly underlying the tin oxide layer, in this illustration, is a tungsten carbon layer **53** (35-55 nm thick). The layer **51** in this illustration is silicon oxide (e.g., TEOS cap), which may reside on a layer of extreme low k dielectric used in BEOL process sequence. First, tin oxide is selectively etched in a presence of the photoresist and tungsten carbon using the highly selective H<sub>2</sub>/CH<sub>4</sub> plasma etch. The recessed features are formed and the tungsten carbon layer is exposed, as shown in FIG. **5I**. Next, tungsten carbon is selectively etched in a presence of tin oxide, exposing the underlying TEOS layer. For example, tungsten carbon can be etched selectively relative to tin oxide using an NF<sub>3</sub>/Cl<sub>2</sub> plasma etch described herein. The photoresist may also be substantially removed during this step. The resulting structure is shown in FIG. **5J**. Next, the tin oxide is removed from the substrate using an etch that is selective to carbon tungsten. In some embodiments it is preferable to remove tin oxide using H<sub>2</sub> plasma. In some embodiments hydrocarbon additives are not used during this step. For example tin oxide can be removed after the underlying layer has been etched using H<sub>2</sub> etch under the following process conditions. In this example the etch involves flowing H<sub>2</sub> at a flow rate of 100-500 sccm, and forming a plasma in this process gas using RF power of 100-500 W (per one 300 mm wafer). This etch can be conducted with or without a substrate bias. For example, substrate bias may be between 0-100 Vb, such as 10-100 Vb. The process can be performed at a temperature of less than 100° C. and a pressure of 5-50 mTorr.

Another process flow with a tin oxide middle layer hardmask is illustrated by the cross-sectional views in FIGS. **5L-5O**. In this example, as shown in FIG. **5L**, a patterned layer of photoresist **57** is formed over the tin oxide layer **55**

(e.g., 9-12 nm thick). The layer of material directly underlying the tin oxide layer, in this illustration, is an amorphous silicon (Si) layer **53** (35-55 nm thick). The layer **51** in this illustration is a silicon oxide etch stop layer. In this illustration the photoresist is deposited such that it is wider at the bottom than at the top. It was shown that with the use of the H<sub>2</sub>/hydrocarbon plasma etch it is possible to reduce the difference in photoresist width and make it substantially rectangular in cross-section. First, tin oxide is selectively etched in a presence of the photoresist and amorphous silicon using the highly selective H<sub>2</sub>/CH<sub>4</sub> plasma etch. The recessed features are formed and the amorphous silicon layer is exposed, while the geometry of photoresist is improved, as shown in FIG. **5M**. Next, silicon is selectively etched in a presence of tin oxide, exposing the underlying etch stop layer. For example, silicon can be etched selectively relative to tin oxide using NF<sub>3</sub>/Cl<sub>2</sub> plasma etch described herein. The etch selectivity of greater than 40 (silicon to tin oxide) can be achieved with this etch. The photoresist may also be partially removed during this step. The resulting structure is shown in FIG. **5N**. Next, the tin oxide is removed from the substrate using an etch that is selective to silicon. In some embodiments it is preferable to remove tin oxide using H<sub>2</sub> plasma. The remaining photoresist **57** can be removed during H<sub>2</sub> plasma treatment. The resulting structure is shown in FIG. **5O**.

The use of tin oxide as a hardmask is highly advantageous because it can be etched with very high selectivity relative to silicon oxide, which is a common layer to be patterned. It can also be selectively etched with a dry plasma etch chemistry (e.g., hydrogen-based or chlorine-based chemistry) to a wide variety of other materials, including carbon, photoresist, metals, metal nitrides, and metal oxides. Tin oxide hardmasks also compare favorably to titanium nitride hardmasks because tin oxide does not require wet etching and can be etched with hydrogen plasma, whereas titanium nitride is typically removed by wet etching methods.

Reverse tone hardmasks. In some embodiments, tin oxide is used in various reverse tone hardmask applications. One exemplary process flow is shown in FIG. **8** and is illustrated by schematic cross-sectional views of a substrate in FIGS. **7A-7C**. The process starts in **801** by providing a substrate having an exposed patterned ashable layer and a plurality of recessed features. Examples of ashable materials include carbon-containing materials such as amorphous carbon, diamond-like carbon, photoresist and organic polymers where the polymers may be undoped or doped with metals or metal oxides. The patterned layer of ashable material can be formed, for example, by depositing a blanket layer of ashable material (e.g., by PECVD or a spin on method), followed by photolithographic patterning. FIG. **7A** illustrates a substrate having a patterned layer of ashable material **703** residing on a sublayer **701** (e.g., Si, SiN, metal nitride or any target or sublayer material described herein). There is a plurality of recessed features on the substrate and layer **701** is exposed at the bottoms of the recessed features. Next, in operation **803**, the recessed features on the substrate are filled with tin oxide (e.g., using CVD). An overburden is also typically formed over the layer of the ashable material **703** in this step. The obtained structure is shown in FIG. **7B**, where the deposited tin oxide **705** fills the gaps between the ashable material **703** and forms an overburden. The overburden can then be removed, e.g., by a chemical mechanical polishing (CMP) operation or a bulk plasma etch (e.g., using a hydrogen-based and/or chlorine-based plasma etch) to expose the ashable material **703**. After planarization, in operation **805**, the ashable material is removed without

substantially removing the tin oxide material (e.g., at least 90% of tin oxide remains) thereby forming a complementary pattern of tin oxide **705** as shown in FIG. **7C**.

In one specific example, a substrate containing a patterned carbon layer residing on a target layer (e.g., silicon oxide, silicon nitride or a metal) is provided. The patterned carbon layer has a plurality of recesses (e.g., with widths of between about 5-50 nm). Next, the recesses are filled with tin oxide and a tin oxide overburden is formed (e.g., CVD). Next, tin oxide overburden is removed (e.g., by CMP or a dry plasma etch that is selective to carbon) to expose carbon, and then the carbon is removed (stripped) e.g., using O<sub>2</sub> plasma, without completely removing the tin oxide.

Another embodiment of a reverse tone mask implementation is shown in a process flow diagram in FIG. **10** and is illustrated by schematic cross-sectional view of the processed substrate in FIGS. **9A-9C**. The process starts in **1001** by providing a substrate having a patterned tin oxide layer and a plurality of recessed features. This is illustrated in FIG. **9A**, where the patterned tin oxide layer **903** resides on a sublayer **901** (e.g., metal nitride, or metal layer). The sublayer **901** is exposed at the bottoms of the recessed features formed in the tin oxide layer **903**. Next, in operation **1003**, the recessed features are filled by a silicon-containing material, e.g., by CVD. Examples of suitable silicon-containing materials include silicon (e.g., amorphous silicon or polysilicon) and silicon-containing compounds, such as silicon oxide, silicon nitride, and silicon carbide. An overburden over the tin oxide layer may be formed during this deposition. The resulting structure is shown in FIG. **9B**, where the silicon-containing material **905** fills the gaps in the patterned tin oxide layer and forms an overburden. Next, the overburden is removed by CMP or by a plasma etch (e.g., a fluorine-based etch, such as a fluorocarbon plasma etch) and the tin oxide **903** is exposed. In the next operation **1005** the tin oxide is removed without removing the silicon-containing material thereby forming a patterned layer of silicon-containing material (reverse tone or complementary pattern to the tin oxide pattern). The tin oxide is etched selectively to the silicon-containing material, for example, using a hydrogen-based etch (e.g., H<sub>2</sub> plasma etch, or HBr plasma etch) or a chlorine-based etch (e.g., BCl<sub>3</sub>/Cl<sub>2</sub> etch). The structure obtained after the etch is shown in FIG. **9C**, where the patterned silicon-containing layer **905** is shown. The sublayer **901** is exposed at the bottoms of the recessed features formed in the silicon-containing material **905**.

In one implementation, a substrate having a target layer with a patterned layer of tin oxide over the target layer, is provided. Next, the recessed features in the patterned tin oxide are filled with silicon oxide, and a silicon oxide overburden is formed (e.g., by PECVD). Next, the silicon oxide overburden is etched (recess etched) to expose tin oxide, and then tin oxide is removed (stripped), e.g., using hydrogen plasma, thereby leaving patterned silicon oxide with a pattern that is complementary to the initial tin oxide pattern.

#### Apparatus

The etching methods described herein can be carried out in a variety of apparatuses. A suitable apparatus includes an etch process chamber, a substrate holder in the etch process chamber configured to hold the substrate in place during etching, and a plasma generating mechanism configured for generating a plasma in a process gas.

Examples of suitable apparatuses include inductively coupled plasma (ICP) reactors which, in certain embodiments, may also be suitable for cyclic deposition and activation processes, including atomic layer etching (ALE)

operations and atomic layer deposition (ALD) operations. Although ICP reactors are described herein in detail, it should be understood that capacitively coupled plasma reactors may also be used.

FIG. 11 schematically shows a cross-sectional view of an inductively coupled plasma integrated etching and deposition apparatus 400 appropriate for implementing plasma etching described herein, an example of which is a Kiyoo® reactor, produced by Lam Research Corp. of Fremont, Calif. The inductively coupled plasma apparatus 400 includes an overall process chamber 424 structurally defined by chamber walls 401 and a window 411. The chamber walls 401 may be fabricated from stainless steel or aluminum. The window 411 may be fabricated from quartz or other dielectric material. An optional internal plasma grid 450 divides the overall process chamber into an upper sub-chamber 402 and a lower sub-chamber 403. In most embodiments, plasma grid 450 may be removed, thereby utilizing a chamber space made of sub-chambers 402 and 403. A chuck 417 is positioned within the lower sub-chamber 403 near the bottom inner surface. The chuck 417 is configured to receive and hold a semiconductor wafer 419 upon which the etching and deposition processes are performed. The chuck 417 can be an electrostatic chuck for supporting the wafer 419 when present. In some embodiments, an edge ring (not shown) surrounds chuck 417, and has an upper surface that is approximately planar with a top surface of the wafer 419, when present over chuck 417. The chuck 417 also includes electrostatic electrodes for chucking and dechucking the wafer 419. A filter and DC clamp power supply (not shown) may be provided for this purpose. Other control systems for lifting the wafer 419 off the chuck 417 can also be provided. The chuck 417 can be electrically charged using an RF power supply 423. The RF power supply 423 is connected to matching circuitry 421 through a connection 427. The matching circuitry 421 is connected to the chuck 417 through a connection 425. In this manner, the RF power supply 423 is connected to the chuck 417. In various embodiments, a bias power of the electrostatic chuck may be set at about 50 Vb or may be set at a different bias power depending on the process performed in accordance with disclosed embodiments. For example, the bias power may be between about 20 Vb and about 100 Vb, or between about 30 Vb and about 150 Vb.

Elements for plasma generation include a coil 433 is positioned above window 411. In some embodiments, a coil is not used in disclosed embodiments. The coil 433 is fabricated from an electrically conductive material and includes at least one complete turn. The example of a coil 433 shown in FIG. 4 includes three turns. The cross-sections of coil 433 are shown with symbols, and coils having an "X" extend rotationally into the page, while coils having a "●" extend rotationally out of the page. Elements for plasma generation also include an RF power supply 441 configured to supply RF power to the coil 433. In general, the RF power supply 441 is connected to matching circuitry 439 through a connection 445. The matching circuitry 439 is connected to the coil 433 through a connection 443. In this manner, the RF power supply 441 is connected to the coil 433. An optional Faraday shield 449a is positioned between the coil 433 and the window 411. The Faraday shield 449a may be maintained in a spaced apart relationship relative to the coil 433. In some embodiments, the Faraday shield 449a is disposed immediately above the window 411. In some embodiments, the Faraday shield 449b is between the window 411 and the chuck 417. In some embodiments, the Faraday shield 449b is not maintained in a spaced apart

relationship relative to the coil 433. For example, the Faraday shield 449b may be directly below the window 411 without a gap. The coil 433, the Faraday shield 449a, and the window 411 are each configured to be substantially parallel to one another. The Faraday shield 449a may prevent metal or other species from depositing on the window 411 of the process chamber 424.

Process gas (e.g. H<sub>2</sub> and He, etc.) may be flowed into the process chamber through one or more main gas flow inlets 460 positioned in the upper sub-chamber 402 and/or through one or more side gas flow inlets 470. Likewise, though not explicitly shown, similar gas flow inlets may be used to supply process gases to a capacitively coupled plasma processing chamber. A vacuum pump, e.g., a one or two stage mechanical dry pump and/or turbomolecular pump 440, may be used to draw process gases out of the process chamber 424 and to maintain a pressure within the process chamber 424. For example, the vacuum pump may be used to evacuate the lower sub-chamber 403 during a purge operation of. A valve-controlled conduit may be used to fluidically connect the vacuum pump to the process chamber 424 so as to selectively control application of the vacuum environment provided by the vacuum pump. This may be done employing a closed-loop-controlled flow restriction device, such as a throttle valve (not shown) or a pendulum valve (not shown), during operational plasma processing. Likewise, a vacuum pump and valve controlled fluidic connection to the capacitively coupled plasma processing chamber may also be employed.

During operation of the apparatus 400, one or more process gases such as an H<sub>2</sub>-containing gas, may be supplied through the gas flow inlets 460 and/or 470. In certain embodiments, process gas may be supplied only through the main gas flow inlet 460, or only through the side gas flow inlet 470. In some cases, the gas flow inlets shown in the figure may be replaced by more complex gas flow inlets, one or more showerheads, for example. The Faraday shield 449a and/or optional grid 450 may include internal channels and holes that allow delivery of process gases to the process chamber 424. Either or both of Faraday shield 449a and optional grid 450 may serve as a showerhead for delivery of process gases. In some embodiments, a liquid vaporization and delivery system may be situated upstream of the process chamber 424, such that once a liquid reactant or precursor is vaporized, the vaporized reactant or precursor is introduced into the process chamber 424 via a gas flow inlet 460 and/or 470.

Radio frequency power is supplied from the RF power supply 441 to the coil 433 to cause an RF current to flow through the coil 433. The RF current flowing through the coil 433 generates an electromagnetic field about the coil 433. The electromagnetic field generates an inductive current within the upper sub-chamber 402. The physical and chemical interactions of various generated ions and radicals with the wafer 419 etch features of and selectively deposit layers on the wafer 419.

If the plasma grid 450 is used such that there is both an upper sub-chamber 402 and a lower sub-chamber 403, the inductive current acts on the gas present in the upper sub-chamber 402 to generate an electron-ion plasma in the upper sub-chamber 402. The optional internal plasma grid 450 limits the amount of hot electrons in the lower sub-chamber 403. In some embodiments, the apparatus 400 is designed and operated such that the plasma present in the lower sub-chamber 403 is an ion-ion plasma.

Both the upper electron-ion plasma and the lower ion-ion plasma may contain positive and negative ions, though the

ion-ion plasma will have a greater ratio of negative ions to positive ions. Volatile etching and/or deposition byproducts may be removed from the lower sub-chamber **403** through port **422**. For example, tin hydride generated during etching of tin oxide using H<sub>2</sub> plasma can be removed through port **422** during purging and/or evacuation. The chuck **417** disclosed herein may operate at elevated temperatures ranging between about 10° C. and about 250° C. The temperature will depend on the process operation and specific recipe. In some embodiments the apparatus is controlled to conduct the etching at a temperature of less than about 100° C.

Apparatus **400** may be coupled to facilities (not shown) when installed in a clean room or a fabrication facility. Facilities include plumbing that provide processing gases, vacuum, temperature control, and environmental particle control. These facilities are coupled to apparatus **400**, when installed in the target fabrication facility. Additionally, apparatus **400** may be coupled to a transfer chamber that allows robotics to transfer semiconductor wafers into and out of apparatus **400** using typical automation.

In some embodiments, a system controller **430** (which may include one or more physical or logical controllers) controls some or all of the operations of a process chamber **424**. The system controller **430** may include one or more memory devices and one or more processors. In some embodiments, the apparatus **400** includes a switching system for controlling flow rates of the process gases. The controller, in some embodiments, includes program instructions for causing the steps of any of the methods provided herein.

In some implementations, the system controller **430** is part of a system, which may be part of the above-described examples. Such systems can include semiconductor processing equipment, including a processing tool or tools, chamber or chambers, a platform or platforms for processing, and/or specific processing components (a wafer pedestal, a gas flow system, etc.). These systems may be integrated with electronics for controlling their operation before, during, and after processing of a semiconductor wafer or substrate. The electronics may be integrated into the system controller **430**, which may control various components or subparts of the system or systems. The system controller, depending on the processing parameters and/or the type of system, may be programmed to control any of the processes disclosed herein, including the delivery of processing gases, temperature settings (e.g., heating and/or cooling), pressure settings, vacuum settings, power settings, radio frequency (RF) generator settings, RF matching circuit settings, frequency settings, flow rate settings, fluid delivery settings, positional and operation settings, wafer transfers into and out of a tool and other transfer tools and/or load locks connected to or interfaced with a specific system.

Broadly speaking, the system controller **430** may be defined as electronics having various integrated circuits, logic, memory, and/or software that receive instructions, issue instructions, control operation, enable cleaning operations, enable endpoint measurements, and the like. The integrated circuits may include chips in the form of firmware that store program instructions, digital signal processors (DSPs), chips defined as application specific integrated circuits (ASICs), and/or one or more microprocessors, or microcontrollers that execute program instructions (e.g., software). Program instructions may be instructions communicated to the controller in the form of various individual settings (or program files), defining operational parameters for carrying out a particular process on or for a semiconductor wafer or to a system. The operational parameters

may, in some embodiments, be part of a recipe defined by process engineers to accomplish one or more processing steps during the fabrication or removal of one or more layers, materials, metals, oxides, silicon, silicon dioxide, surfaces, circuits, and/or dies of a wafer.

The system controller **430**, in some implementations, may be a part of or coupled to a computer that is integrated with, coupled to the system, otherwise networked to the system, or a combination thereof. For example, the controller may be in the “cloud” or all or a part of a fab host computer system, which can allow for remote access of the wafer processing. The computer may enable remote access to the system to monitor current progress of fabrication operations, examine a history of past fabrication operations, examine trends or performance metrics from a plurality of fabrication operations, to change parameters of current processing, to set processing steps to follow a current processing, or to start a new process. In some examples, a remote computer (e.g. a server) can provide process recipes to a system over a network, which may include a local network or the Internet. The remote computer may include a user interface that enables entry or programming of parameters and/or settings, which are then communicated to the system from the remote computer. In some examples, the system controller **430** receives instructions in the form of data, which specify parameters for each of the processing steps to be performed during one or more operations. It should be understood that the parameters may be specific to the type of process to be performed and the type of tool that the controller is configured to interface with or control. Thus as described above, the system controller **430** may be distributed, such as by including one or more discrete controllers that are networked together and working towards a common purpose, such as the processes and controls described herein. An example of a distributed controller for such purposes would be one or more integrated circuits on a chamber in communication with one or more integrated circuits located remotely (such as at the platform level or as part of a remote computer) that combine to control a process on the chamber.

Without limitation, example systems may include a plasma etch chamber or module, a deposition chamber or module, a spin-rinse chamber or module, a metal plating chamber or module, a clean chamber or module, a bevel edge etch chamber or module, a physical vapor deposition (PVD) chamber or module, a chemical vapor deposition (CVD) chamber or module, an ALD chamber or module, an ALE chamber or module, an ion implantation chamber or module, a track chamber or module, and any other semiconductor processing systems that may be associated or used in the fabrication and/or manufacturing of semiconductor wafers.

As noted above, depending on the process step or steps to be performed by the tool, the controller might communicate with one or more of other tool circuits or modules, other tool components, cluster tools, other tool interfaces, adjacent tools, neighboring tools, tools located throughout a factory, a main computer, another controller, or tools used in material transport that bring containers of wafers to and from tool locations and/or load ports in a semiconductor manufacturing factory.

FIG. 12 depicts a semiconductor process cluster architecture with various modules that interface with a vacuum transfer module **538** (VTM). The arrangement of various modules to “transfer” wafers among multiple storage facilities and processing modules may be referred to as a “cluster tool architecture” system. Airlock **530**, also known as a loadlock or transfer module, interfaces with the VTM **538**

which, in turn, interfaces with four processing modules **520a-520d**, which may be individual optimized to perform various fabrication processes. By way of example, processing modules **520a-520d** may be implemented to perform substrate etching, deposition, ion implantation, wafer cleaning, sputtering, and/or other semiconductor processes. In some embodiments, tin oxide deposition and tin oxide etching are performed in the same module. In some embodiments, tin oxide deposition and tin oxide etching are performed in different modules of the same tool. One or more of the substrate etching processing modules (any of **520a-520d**) may be implemented as disclosed herein, e.g., for depositing conformal films, selectively etching tin oxide, forming air gaps, and other suitable functions in accordance with the disclosed embodiments. Airlock **530** and processing modules **520a-520d** may be referred to as “stations.” Each station has a facet **536** that interfaces the station to VTM **538**. Inside each facet, sensors **1-18** are used to detect the passing of wafer **526** when moved between respective stations.

Robot **522** transfers wafer **526** between stations. In one embodiment, robot **522** has one arm, and in another embodiment, robot **522** has two arms, where each arm has an end effector **524** to pick wafers such as wafer **526** for transport. Front-end robot **532**, in atmospheric transfer module (ATM) **540**, is used to transfer wafers **526** from cassette or Front Opening Unified Pod (FOUP) **534** in Load Port Module (LPM) **542** to airlock **530**. Module center **528** inside processing modules **520a-520d** is one location for placing wafer **526**. Aligner **544** in ATM **540** is used to align wafers.

In an exemplary processing method, a wafer is placed in one of the FOUPs **534** in the LPM **542**. Front-end robot **532** transfers the wafer from the FOUP **534** to an aligner **544**, which allows the wafer **526** to be properly centered before it is etched or processed. After being aligned, the wafer **526** is moved by the front-end robot **532** into an airlock **530**. Because the airlock **530** has the ability to match the environment between an ATM **540** and a VTM **538**, the wafer **526** is able to move between the two pressure environments without being damaged. From the airlock **530**, the wafer **526** is moved by robot **522** through VTM **538** and into one of the processing modules **520a-520d**. In order to achieve this wafer movement, the robot **522** uses end effectors **524** on each of its arms. Once the wafer **526** has been processed, it is moved by robot **522** from the processing modules **520a-520d** to the airlock **530**. From here, the wafer **526** may be moved by the front-end robot **532** to one of the FOUPs **534** or to the aligner **544**.

It should be noted that the computer controlling the wafer movement can be local to the cluster architecture, or can be located external to the cluster architecture in the manufacturing floor, or in a remote location and connected to the cluster architecture via a network. A controller as described above with respect to FIG. **11** may be implemented with the tool in FIG. **12**. Machine-readable media containing instructions for controlling process operations in accordance with the present invention may be coupled to the system controller.

In some embodiments an apparatus is provided, where the apparatus includes a process chamber having a substrate holder configured for holding the semiconductor substrate during etching; a plasma generator configured for generating a plasma in a process gas; and a controller. The controller includes program instructions for implementing any of the methods describing herein.

In another aspect a non-transitory computer machine-readable medium is provided, where it includes code for causing the performance of any of the methods described herein.

In another aspect, a system for forming spacers or hard-masks on a semiconductor substrate is provided. The system includes one or more deposition chambers; one or more etch chambers; and a controller. The controller includes program instructions for implementing any methods described herein.

In another aspect, the system includes any of the apparatuses and systems described herein and a stepper. In another aspect, a system for processing a semiconductor substrate is provided. In one embodiment the system includes: one or more deposition chambers; one or more etch chambers; and a system controller comprising program instructions for: (i) causing a deposition of a tin oxide layer over horizontal surfaces and sidewalls of a plurality of protruding features on the semiconductor substrate; (ii) causing a formation of a passivation layer on the tin oxide layer at the sidewalls of the protruding features, and (iii) causing a removal of the tin oxide layer from horizontal surfaces of the protruding features, without causing a removal of the tin oxide layer over the sidewalls of the protruding features.

#### Further Implementations

The apparatus and processes described herein may be used in conjunction with lithographic patterning tools or processes, for example, for the fabrication or manufacture of semiconductor devices, displays, LEDs, photovoltaic panels, and the like. Typically, though not necessarily, such apparatus and processes will be used or conducted together in a common fabrication facility. Lithographic patterning of a film typically comprises some or all of the following steps, each step enabled with a number of possible tools: (1) application of photoresist on a work piece, i.e., a substrate, using a spin-on or spray-on tool; (2) curing of photoresist using a hot plate or furnace or UV curing tool; (3) exposing the photoresist to visible or UV or x-ray light with a tool such as a wafer stepper; (4) developing the resist so as to selectively remove resist and thereby pattern it using a tool such as a wet bench; (5) transferring the resist pattern into an underlying film or work piece by using a dry or plasma-assisted etching tool; and (6) removing the resist using a tool such as an RF or microwave plasma resist stripper.

What is claimed is:

1. A method of processing a semiconductor substrate, the method comprising:

- (a) providing a semiconductor substrate having a plurality of protruding features, the protruding features having horizontal surfaces and sidewalls;
- (b) forming a tin oxide layer on the horizontal surfaces and the sidewalls of the protruding features;
- (c) forming a passivation layer over the tin oxide layer at the sidewalls of the protruding features, such that gaps between adjacent protruding features remain unfilled after formation of the passivation layer; and
- (d) after the passivation layer is formed, etching and completely removing tin oxide from the horizontal surfaces of the protruding features and thereby exposing a material of the protruding features, without completely removing tin oxide residing at the sidewalls of the protruding features.

2. The method of claim 1, wherein the material of the protruding features exposed in (d) is selected from the group consisting of a silicon-containing material, a carbon-containing material, and a metal oxide.

3. The method of claim 1, wherein (d) comprises etching the tin oxide using a hydrogen-based etch chemistry that results in a formation of a tin hydride.

4. The method of claim 1, wherein (d) comprises etching the tin oxide using a hydrogen-based etch chemistry, by contacting the semiconductor substrate with a plasma-activated hydrogen-containing reactant selected from the group consisting of H<sub>2</sub>, HBr, NH<sub>3</sub>, H<sub>2</sub>O, a hydrocarbon, and combinations thereof.

5. The method of claim 1, wherein (d) comprises etching tin oxide using a chlorine-based etch chemistry that comprises exposing the semiconductor substrate to a plasma-activated chlorine-containing reactant selected from the group consisting of Cl<sub>2</sub>, BCl<sub>3</sub>, and combinations thereof.

6. The method of claim 1, wherein the material of the protruding features exposed in (d) is selected from the group consisting of SiO<sub>2</sub>, SiN, SiOC, SiC, SiCN, SiCNO, and SiOC, and wherein (d) comprises etching tin oxide using a hydrogen-based etch chemistry that results in a formation of a tin hydride.

7. The method of claim 1, wherein the protruding features are silicon oxide covered silicon protruding features and wherein (d) comprises etching tin oxide using a hydrogen-based etch chemistry that results in a formation of a tin hydride, and exposing the silicon oxide material.

8. The method of claim 1, wherein the protruding features are carbon protruding features or photoresist protruding features.

9. The method of claim 1, wherein the protruding features are metal oxide protruding features selected from the group consisting of TaO, TiO, WO, ZrO, and HfO.

10. The method of claim 1, wherein forming the passivation layer over the tin oxide layer at the sidewalls of the protruding features comprises depositing a passivation material over both the horizontal surfaces and the sidewalls of the protruding features, followed by removal of the passivation material from the horizontal surfaces of the protruding features.

11. The method of claim 1, wherein forming the passivation layer over the tin oxide layer at the sidewalls of the protruding features comprises depositing a silicon-containing passivation material over both the horizontal surfaces and the sidewalls of the protruding features, followed by removal of the silicon-containing passivation material from

the horizontal surfaces of the protruding features using a fluorocarbon-based etch chemistry.

12. The method of claim 1, wherein forming the passivation layer over the tin oxide layer at the sidewalls of the protruding features comprises depositing a carbon-containing passivation material over both the horizontal surfaces and the sidewalls of the protruding features, followed by removal of the carbon-containing passivation material from the horizontal surfaces.

13. The method of claim 1, wherein forming the passivation layer over the tin oxide layer at the sidewalls of the protruding features comprises converting an outer portion of the tin oxide layer to a tin-containing passivation material selected from the group consisting of SnN, SnBr, SnF.

14. The method of claim 1, wherein forming the passivation layer over the tin oxide layer at the sidewalls of the protruding features comprises converting an outer portion of the tin oxide layer to tin nitride by contacting the substrate with a nitrogen-containing reactant in a plasma.

15. The method of claim 1, wherein (d) comprises etching the tin oxide layer using a plasma formed in a gas comprising Cl<sub>2</sub> and BCl<sub>3</sub>, followed by etching the tin oxide layer with a plasma formed in an H<sub>2</sub>-containing gas.

16. The method of claim 1, wherein the semiconductor substrate provided in (a) further comprises an exposed material selected from the group consisting of silicon oxide, titanium oxide, zirconium oxide, and tungsten oxide between the protruding features.

17. The method of claim 1, further comprising removing the protruding features after (d) without completely removing the tin oxide layer that resided at the sidewalls of the protruding features, thereby forming tin oxide spacers.

18. The method of claim 1, wherein the tin oxide layer is deposited conformally to a thickness of between about 5-30 nm.

19. The method of claim 1, wherein the passivation layer has a thickness of 1-5 nm.

20. The method of claim 1, further comprising:  
 applying photoresist to the substrate;  
 exposing the photoresist to light;  
 patterning the photoresist and transferring the pattern to the substrate;  
 and selectively removing the photoresist from the substrate.

\* \* \* \* \*