



(12) **United States Patent**
Kim et al.

(10) **Patent No.:** **US 10,530,620 B2**
(45) **Date of Patent:** ***Jan. 7, 2020**

(54) **APPARATUS AND METHOD FOR SENDING AND RECEIVING BROADCAST SIGNALS**

(71) Applicant: **LG ELECTRONICS INC.**, Seoul (KR)

(72) Inventors: **Jaehyung Kim**, Seoul (KR); **Woosuk Ko**, Seoul (KR); **Chulkyu Mun**, Seoul (KR); **Sungryong Hong**, Seoul (KR)

(73) Assignee: **LG ELECTRONICS INC.**, Seoul (KR)

(*) Notice: Subject to any disclaimer, the term of this patent is extended or adjusted under 35 U.S.C. 154(b) by 0 days.

This patent is subject to a terminal disclaimer.

(21) Appl. No.: **16/118,943**

(22) Filed: **Aug. 31, 2018**

(65) **Prior Publication Data**

US 2018/0375702 A1 Dec. 27, 2018

Related U.S. Application Data

(63) Continuation of application No. 15/656,796, filed on Jul. 21, 2017, now Pat. No. 10,103,915, which is a (Continued)

(51) **Int. Cl.**
H04L 27/22 (2006.01)
H04L 27/26 (2006.01)
(Continued)

(52) **U.S. Cl.**
CPC **H04L 27/2601** (2013.01); **H04L 1/0041** (2013.01); **H04L 1/0042** (2013.01);
(Continued)

(58) **Field of Classification Search**

CPC H04L 27/2634; H04L 27/2601; H04L 27/265; H04L 27/2605; H04L 1/0041;
(Continued)

(56) **References Cited**

U.S. PATENT DOCUMENTS

8,179,863 B2 5/2012 Yokoyama et al.
9,742,604 B2 8/2017 Kim et al.
(Continued)

FOREIGN PATENT DOCUMENTS

EP 2618563 A2 7/2013
JP 2011045111 A 3/2011
(Continued)

OTHER PUBLICATIONS

ETSI TS 102 831 V1.1.1—Digital Video Broadcasting (DVB); Implementation guidelines for a second generation digital terrestrial television broadcasting system (DVB-T2) (Oct. 2010).

(Continued)

Primary Examiner — Siu M Lee

(74) *Attorney, Agent, or Firm* — Dentons US LLP

(57) **ABSTRACT**

A broadcast signal receiver is disclosed. A broadcast signal receiver according to an embodiment of the present invention comprises a synchronization & demodulation module performing signal detection and OFDM demodulation on a received broadcast signal; a frame parsing & deinterleaving module performing parsing and deinterleaving of a signal frame of the broadcast signal; a demapping & decoding module performing conversion of data of at least one Physical Layer Pipe (PLP) of the broadcast signal into the bit domain and FEC decoding of the converted PLP data; and an output processing module outputting a data stream by receiving the at least one PLP data.

8 Claims, 40 Drawing Sheets

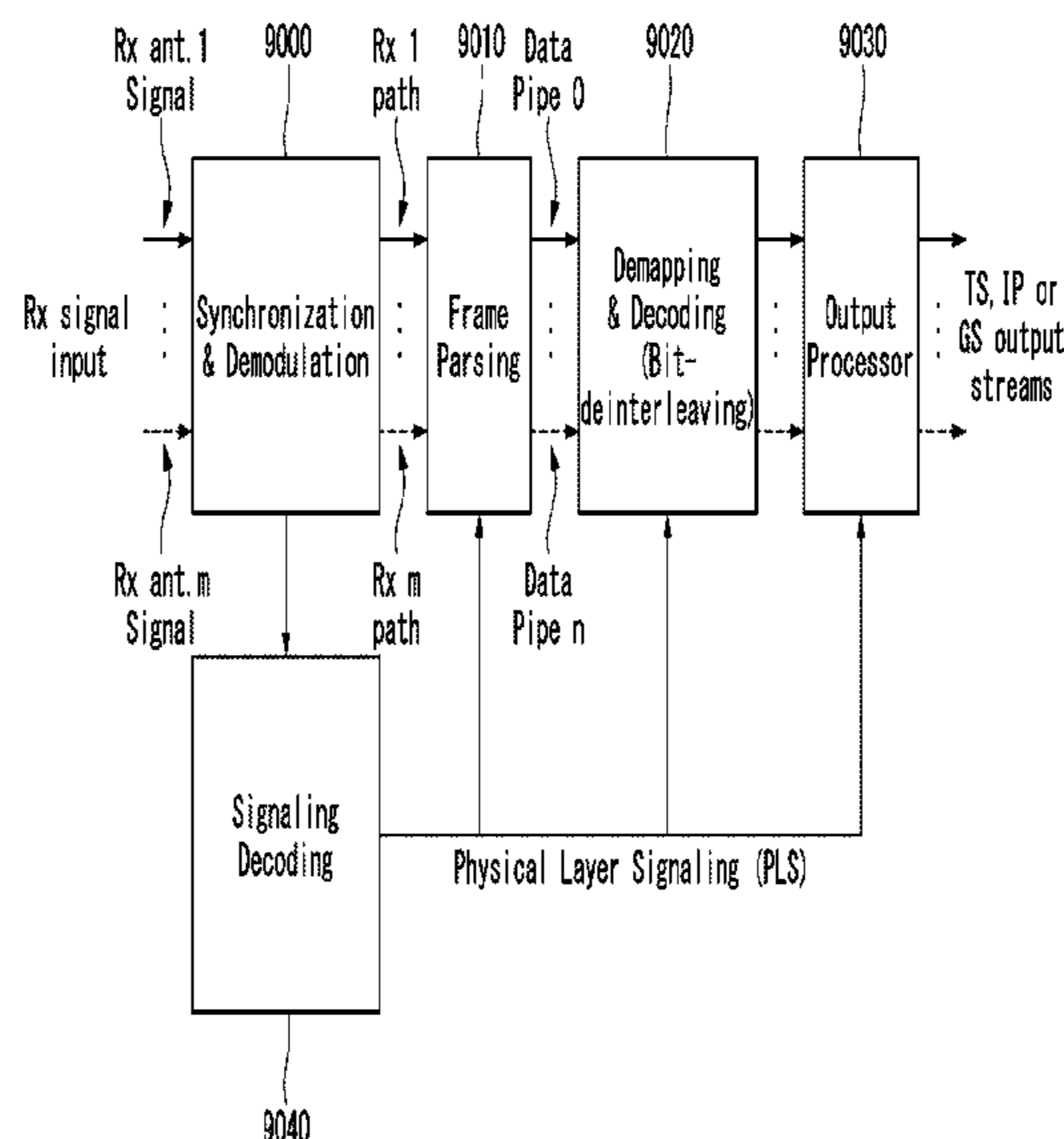

Related U.S. Application Data

continuation of application No. 15/014,838, filed on Feb. 3, 2016, now Pat. No. 9,742,604.

(60) Provisional application No. 62/111,673, filed on Feb. 4, 2015, provisional application No. 62/173,909, filed on Jun. 10, 2015, provisional application No. 62/115,630, filed on Feb. 12, 2015.

(51) **Int. Cl.**
H04L 1/00 (2006.01)
H04L 25/02 (2006.01)

(52) **U.S. Cl.**
 CPC *H04L 1/0071* (2013.01); *H04L 1/0075* (2013.01); *H04L 25/0232* (2013.01); *H04L 27/265* (2013.01); *H04L 27/2611* (2013.01); *H04L 27/2613* (2013.01); *H04L 27/2656* (2013.01); *H04L 27/2662* (2013.01); *H04L 27/2666* (2013.01); *H04L 2001/0093* (2013.01)

(58) **Field of Classification Search**
 CPC ... H04L 1/0071; H04L 1/0075; H04L 1/0042; H04L 2001/0093
 See application file for complete search history.

(56) **References Cited**

U.S. PATENT DOCUMENTS

9,768,995	B2	9/2017	Kim et al.	
10,103,915	B2 *	10/2018	Kim	H04L 1/0042
2006/0280113	A1	12/2006	Huo	
2008/0165710	A1	7/2008	Parts et al.	
2010/0195668	A1	8/2010	Robert et al.	
2010/0226451	A1 *	9/2010	Park	H04L 5/0048 375/260
2012/0155577	A1	6/2012	Shukla et al.	
2012/0224659	A1	9/2012	Yu et al.	
2013/0219431	A1	8/2013	Hong et al.	

2013/0321707	A1 *	12/2013	Takahashi	H04H 20/77 348/723
2014/0105322	A1	4/2014	Ouchi et al.	
2014/0105328	A1	4/2014	Ko et al.	
2014/0149832	A1 *	5/2014	Ko	H04L 1/0041 714/790
2014/0314177	A1	10/2014	Choi et al.	
2015/0010096	A1	1/2015	Kim et al.	
2016/0226687	A1	8/2016	Kim	
2016/0241365	A1 *	8/2016	Bae	H04L 5/0007
2017/0353196	A1	12/2017	Ko et al.	
2017/0366379	A9	12/2017	Baek et al.	

FOREIGN PATENT DOCUMENTS

JP	4991692	B2	8/2012
KR	1020070110925	A	11/2007
KR	100910947	B1	8/2009
KR	1020090090968	A	8/2009
KR	10-2010-0042294	A	4/2010
KR	1020100114442	A	10/2010
KR	1020110129380	A	12/2011
KR	10-2013-0093773	A	8/2013
KR	1020130119281	A	10/2013
WO	2011/105760	A2	9/2011
WO	2011/136574	A2	11/2011
WO	2012/036429	A2	3/2012
WO	2014/195303	A1	12/2014
WO	2014/204181	A1	12/2014
WO	2012176459	A1	2/2015

OTHER PUBLICATIONS

DVB Organization: "TM-NGH1212 98 P1 Symbol insertion Clause 10 Annexes A B C1.docx.," DVB, Digital Video Broadcasting, Nov. 25, 2011, paragraph 9.8.1, XP017838347.
 "Digital Video Broadcasting (DVB); Frame structure channel coding and modulation for a second generation digital terrestrial television broadcasting system (DVB-T2)," DVB Bluebook A122, Jun. 1, 2010, pp. 1-179, XP055075830.

* cited by examiner

[Figure 1]

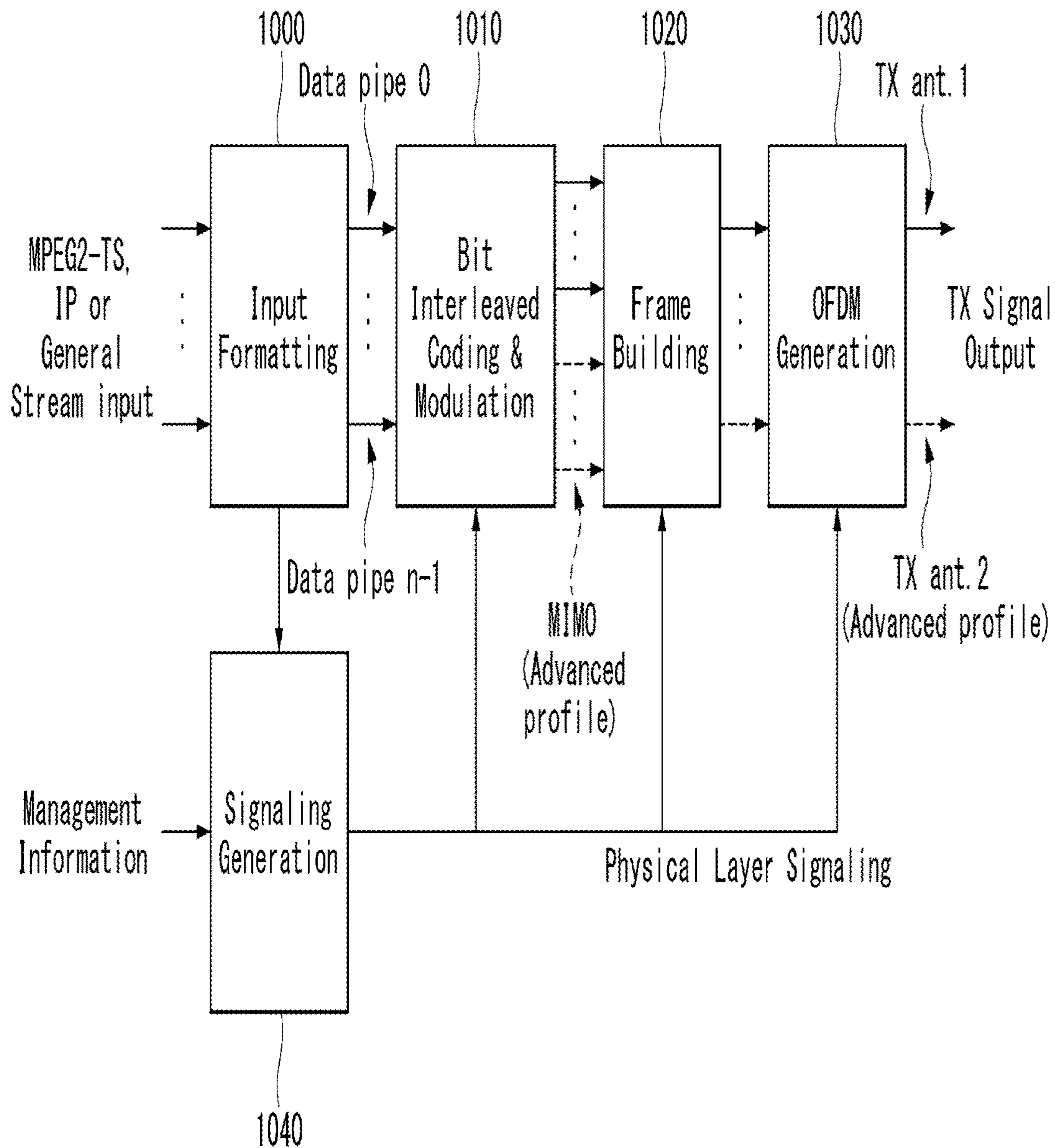

[Figure 2]

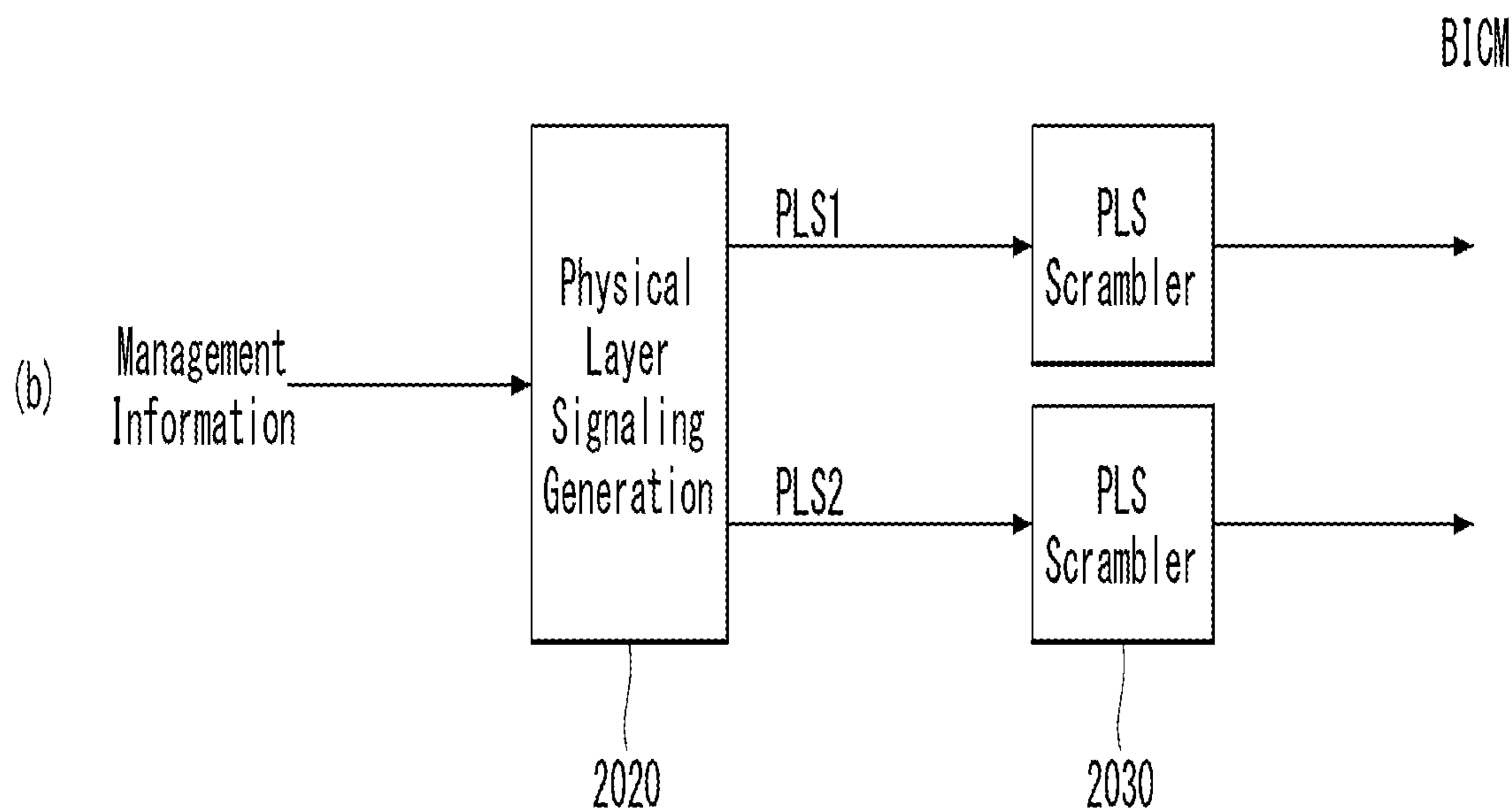
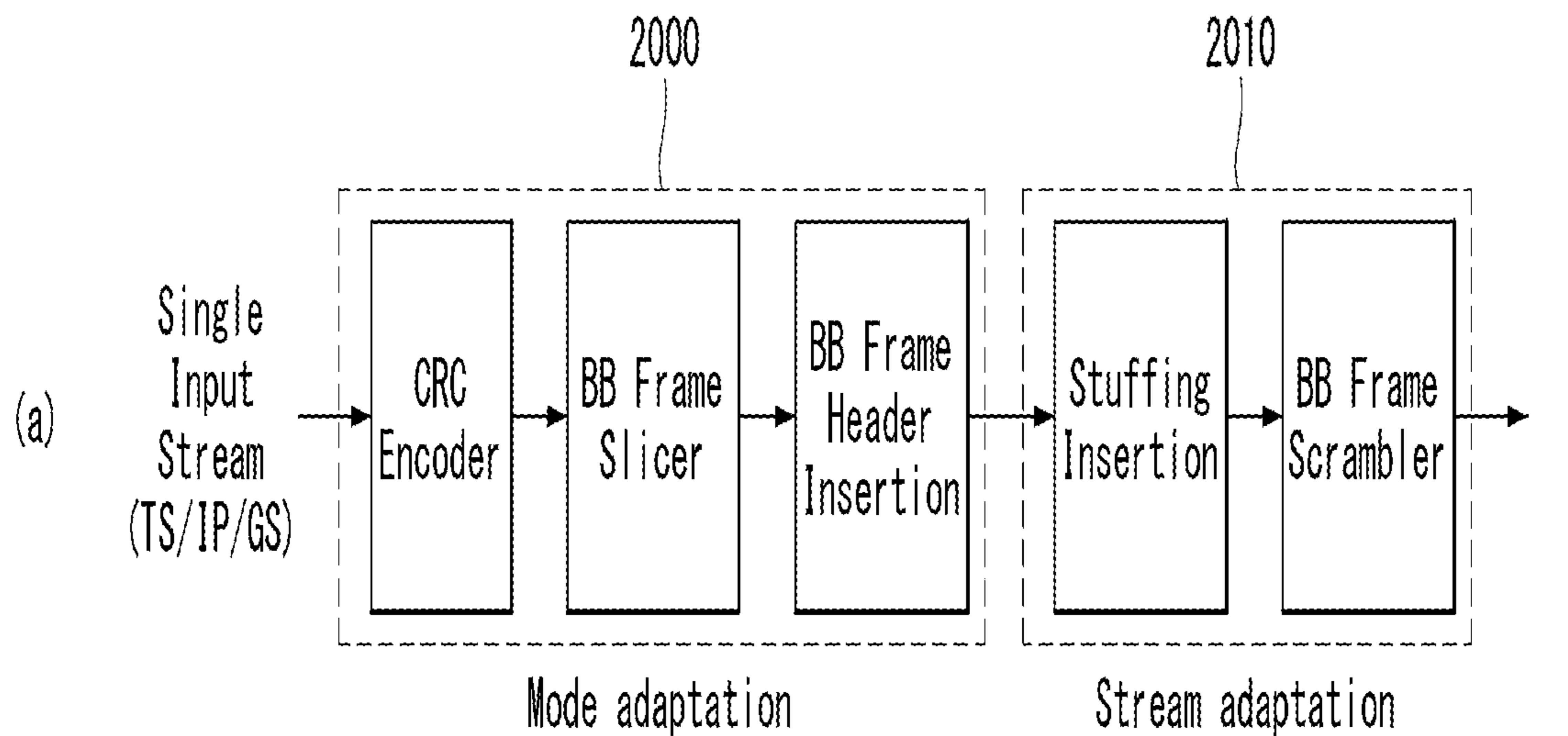

[Figure 3]

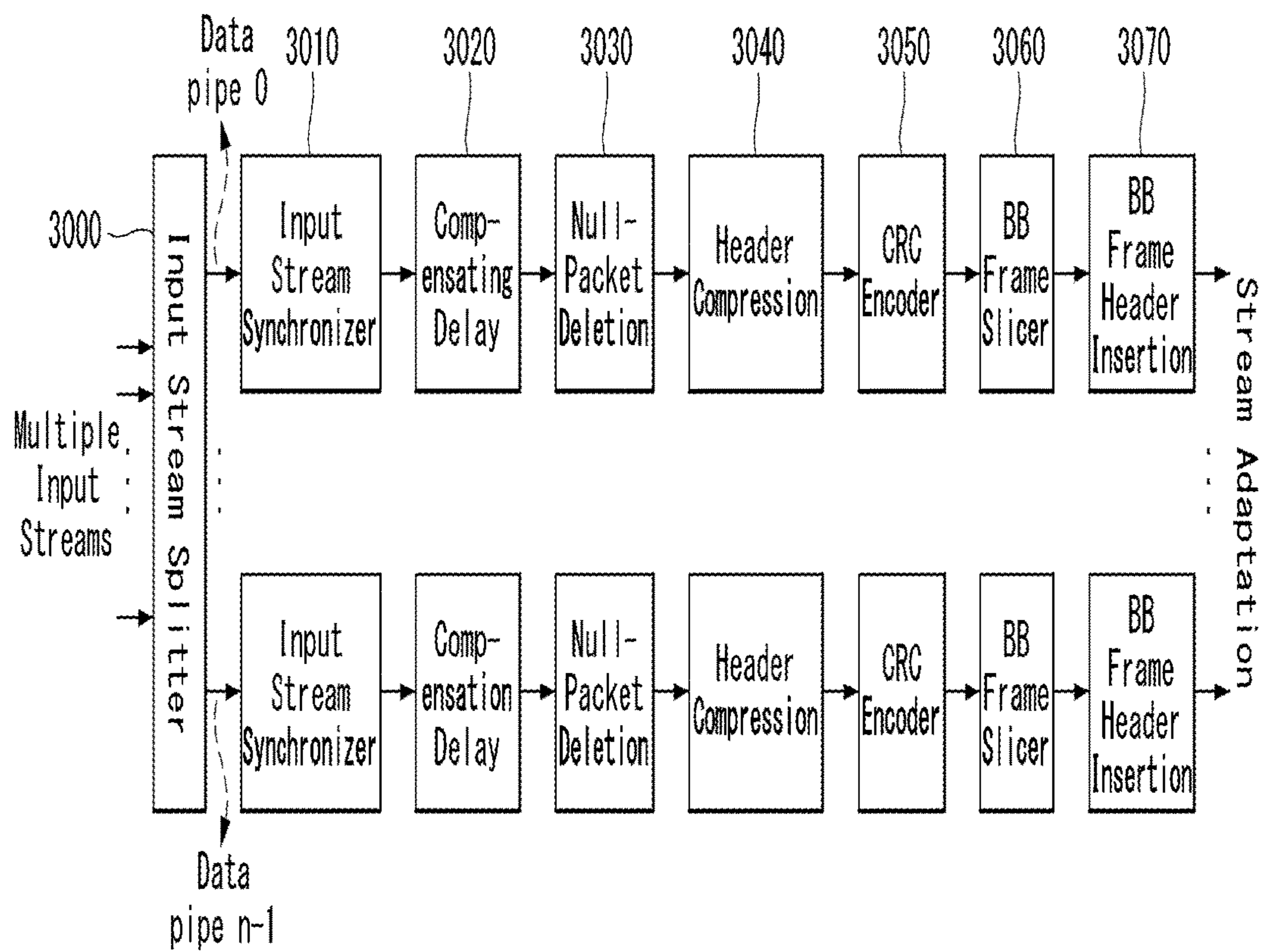

[Figure 4]

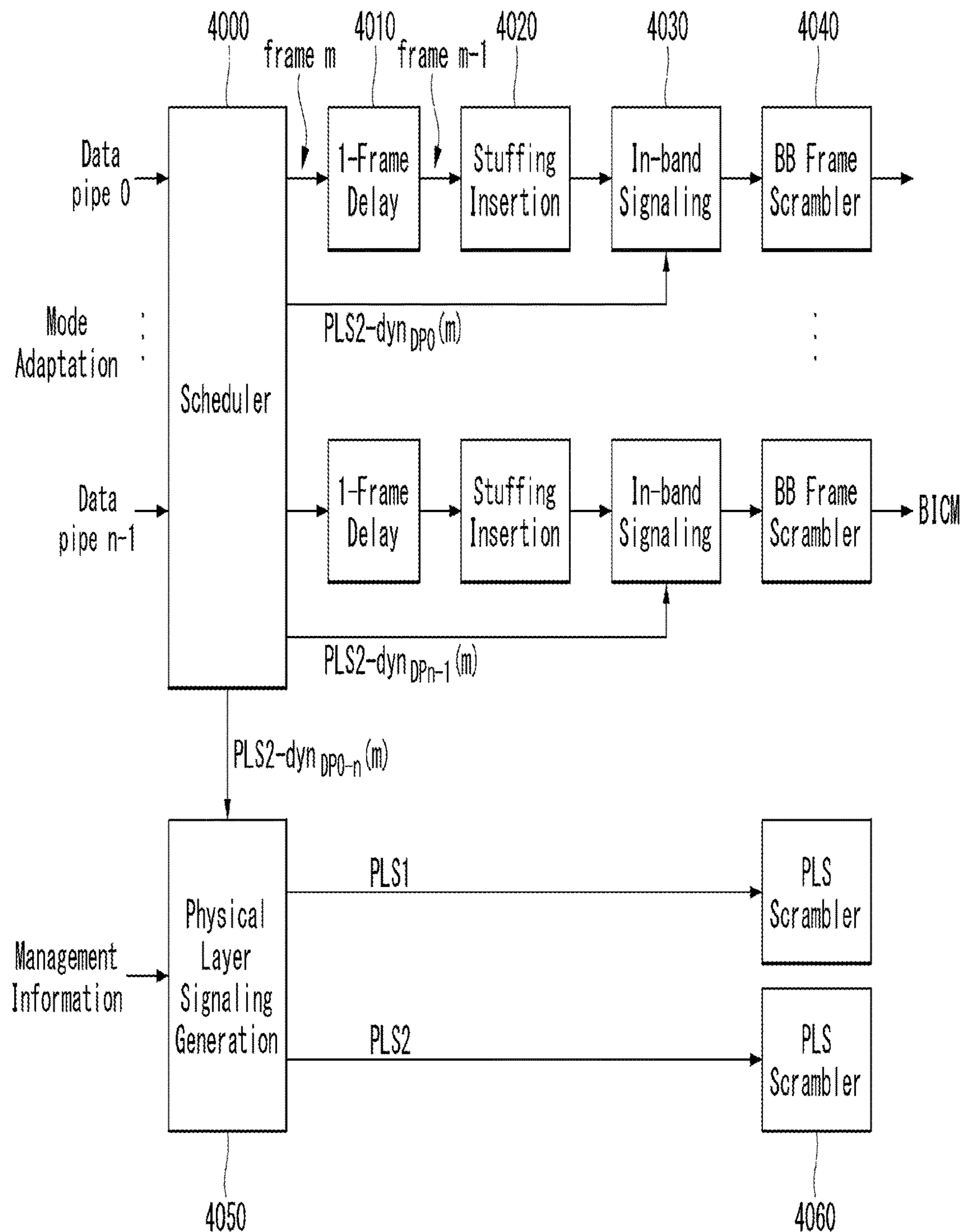

[Figure 5]

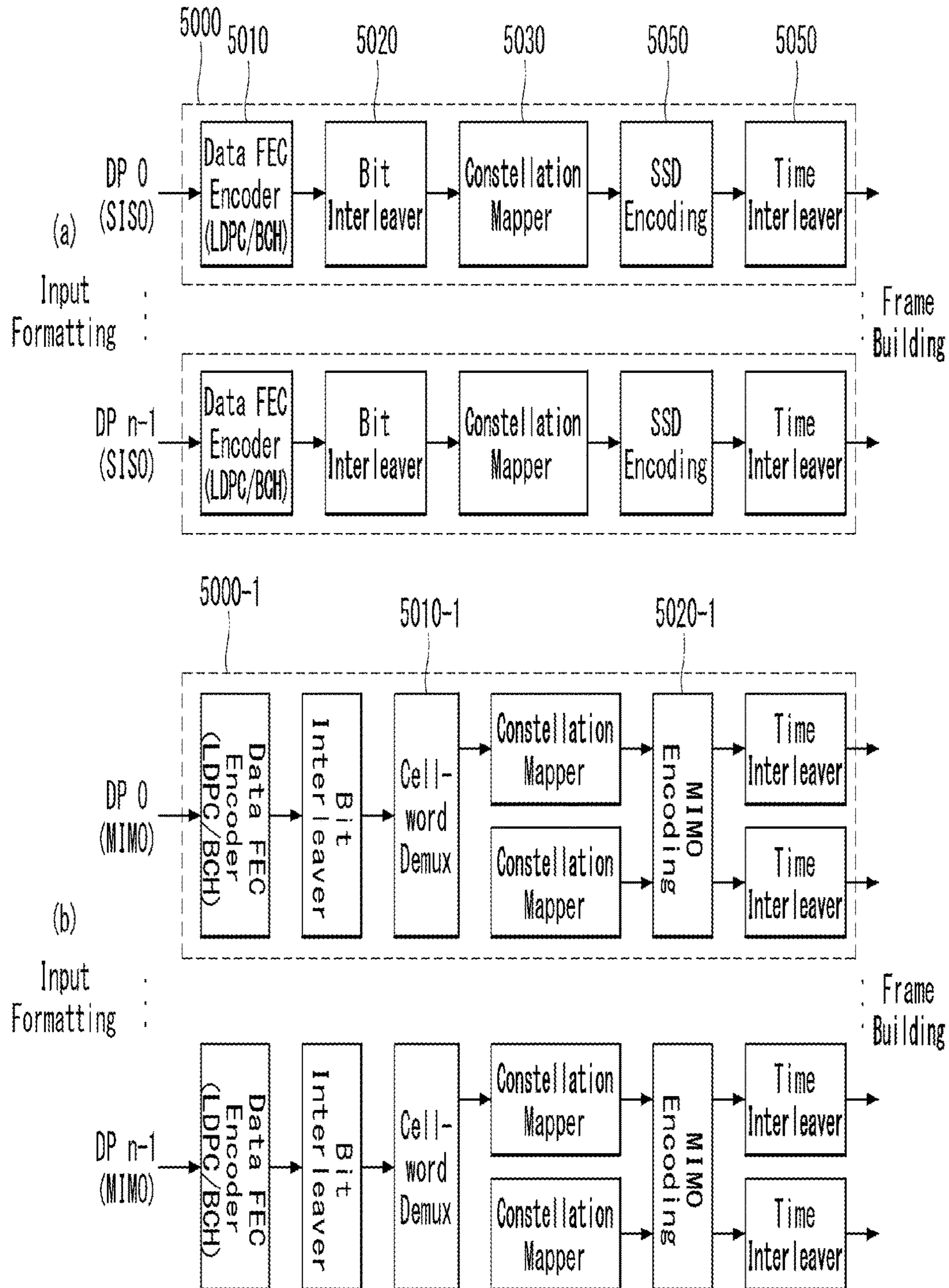

[Figure 6]

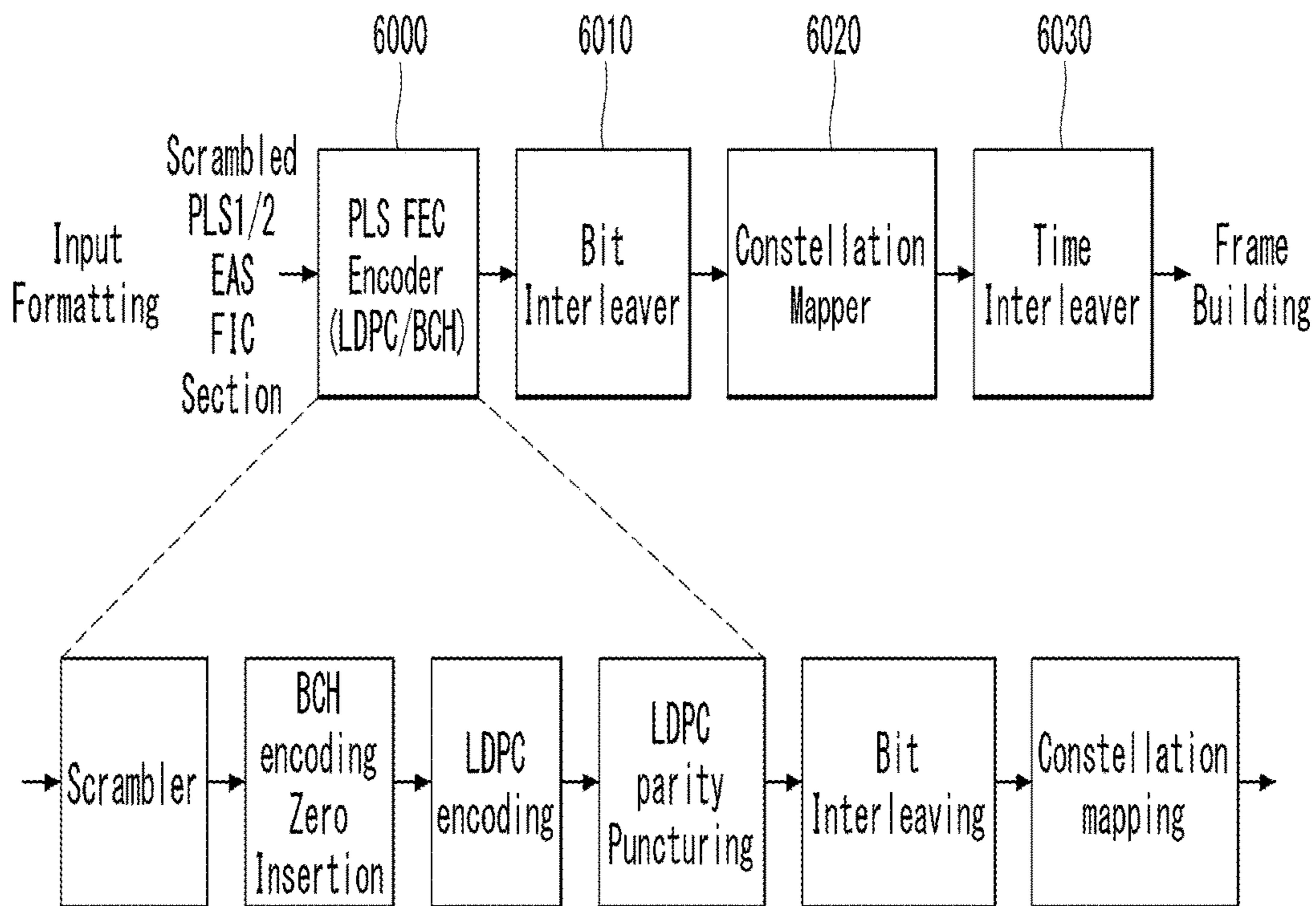

[Figure 7]

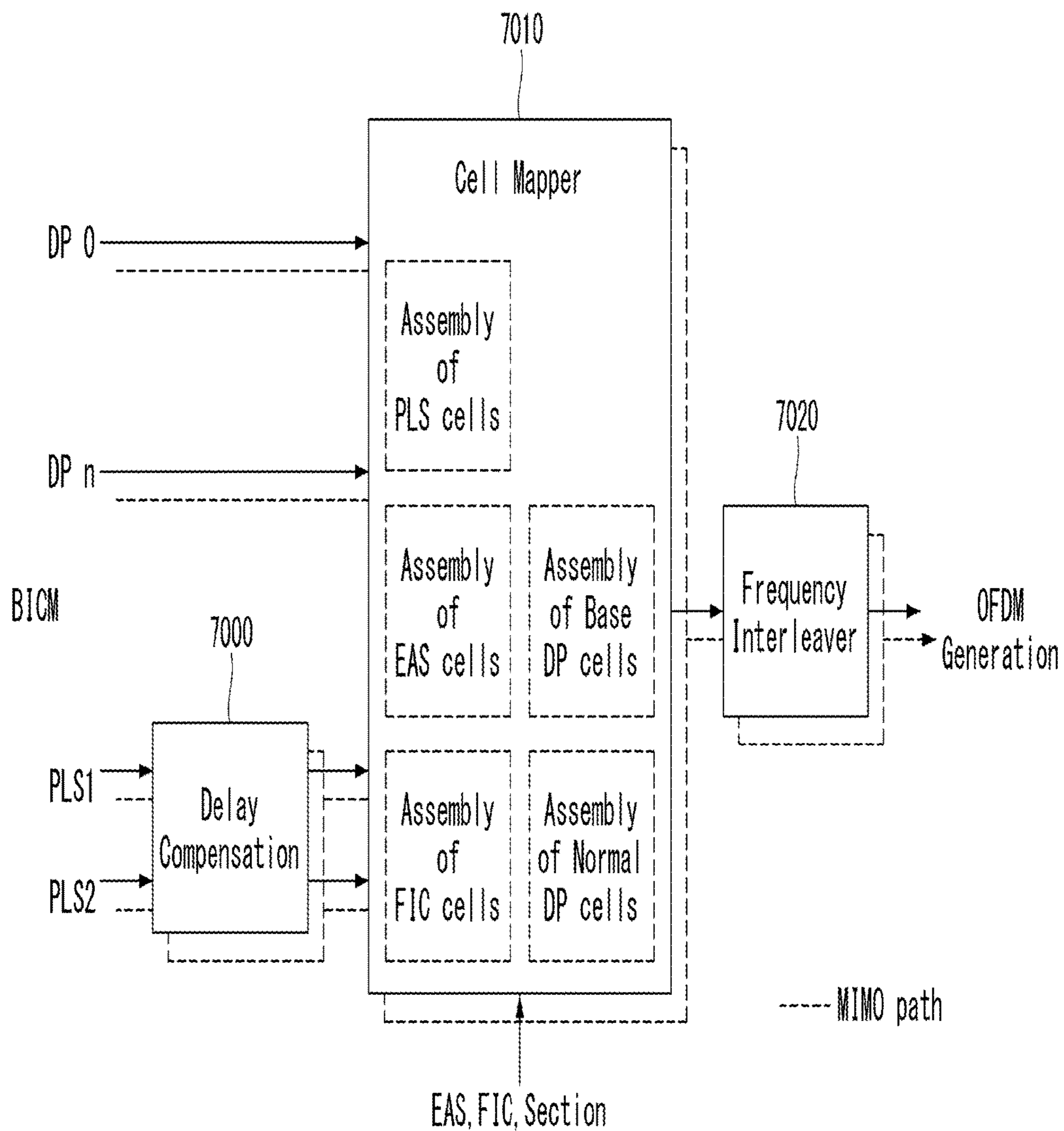

[Figure 8]

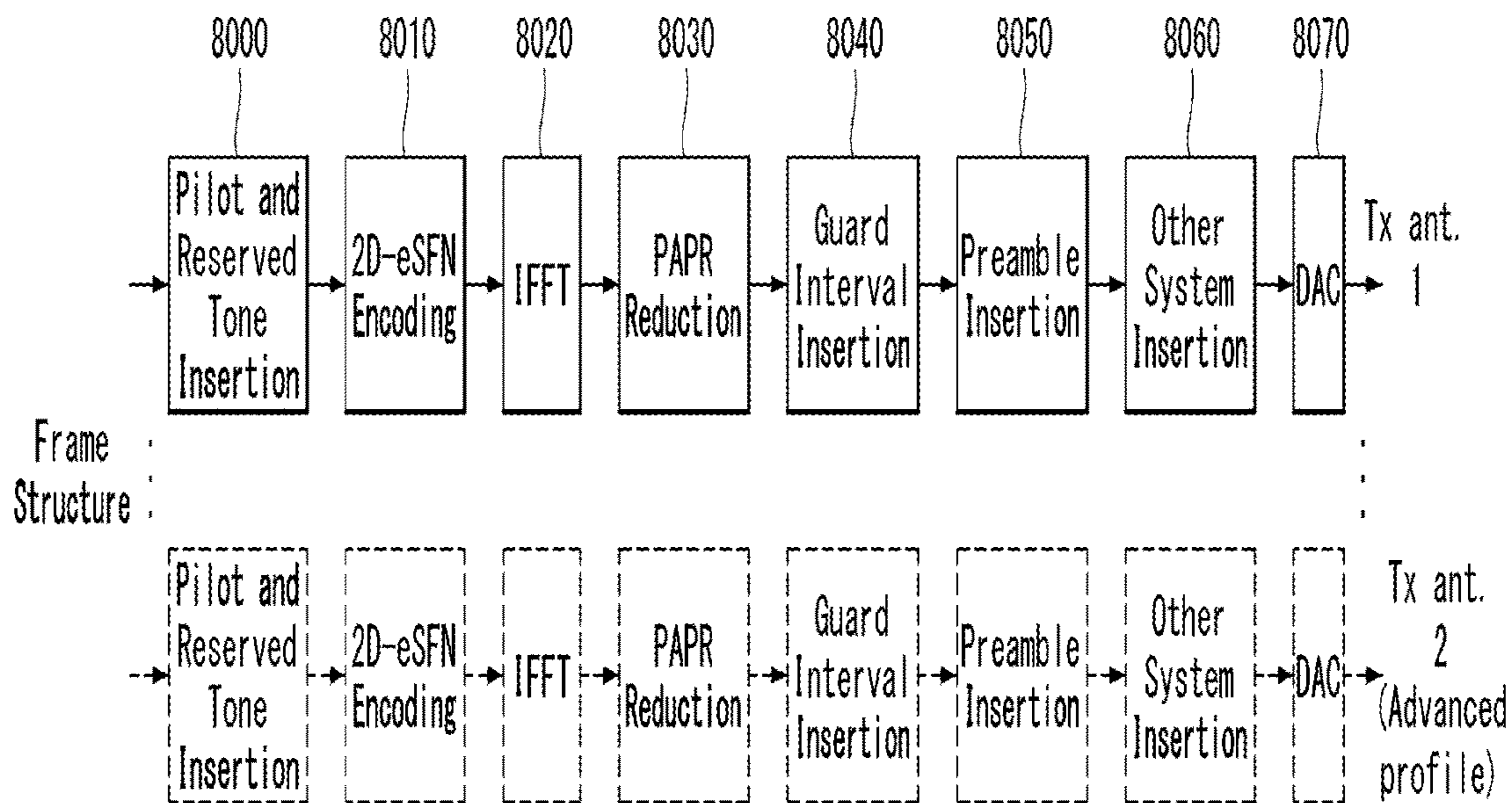

[Figure 9]

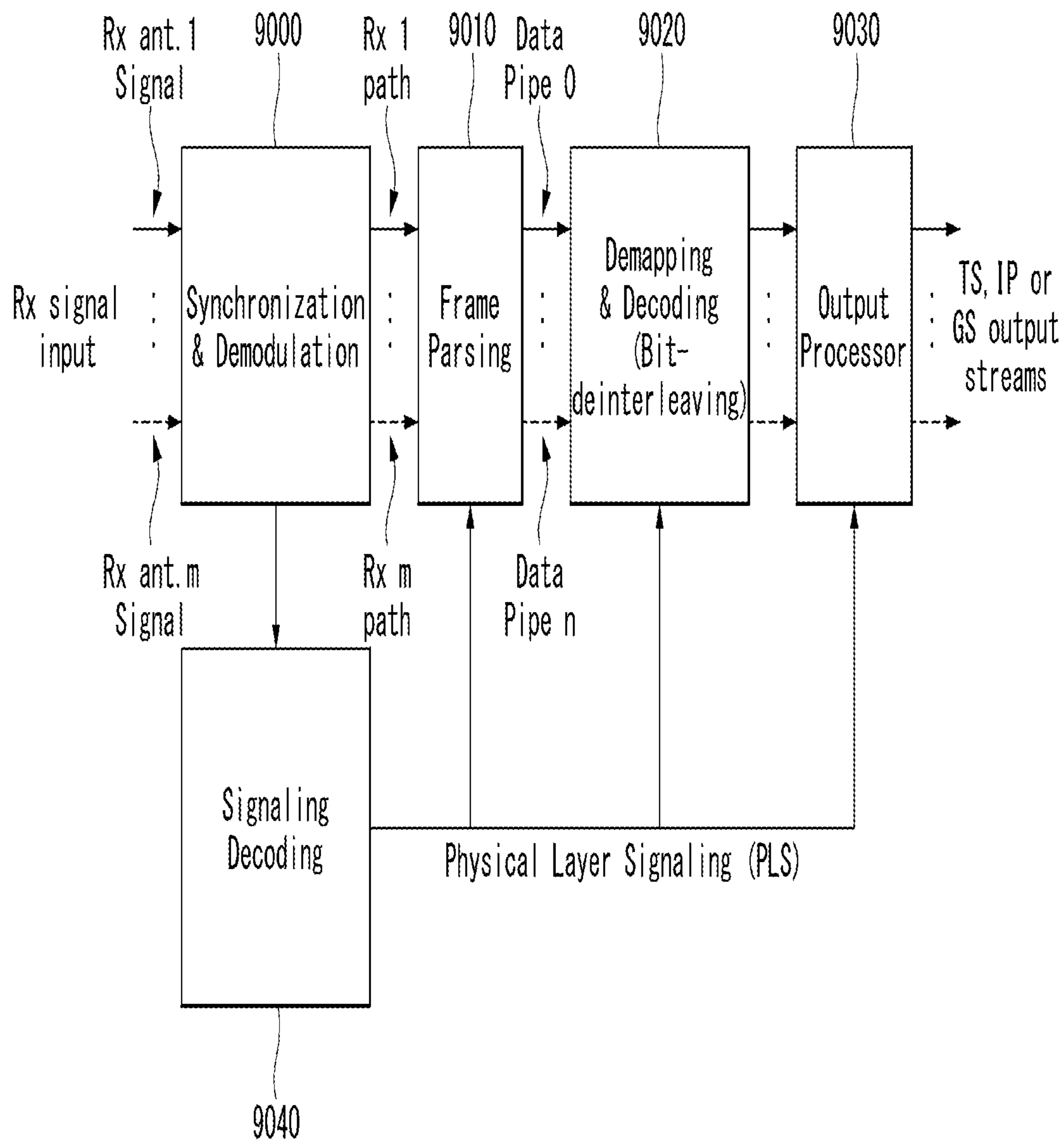

[Figure 10]

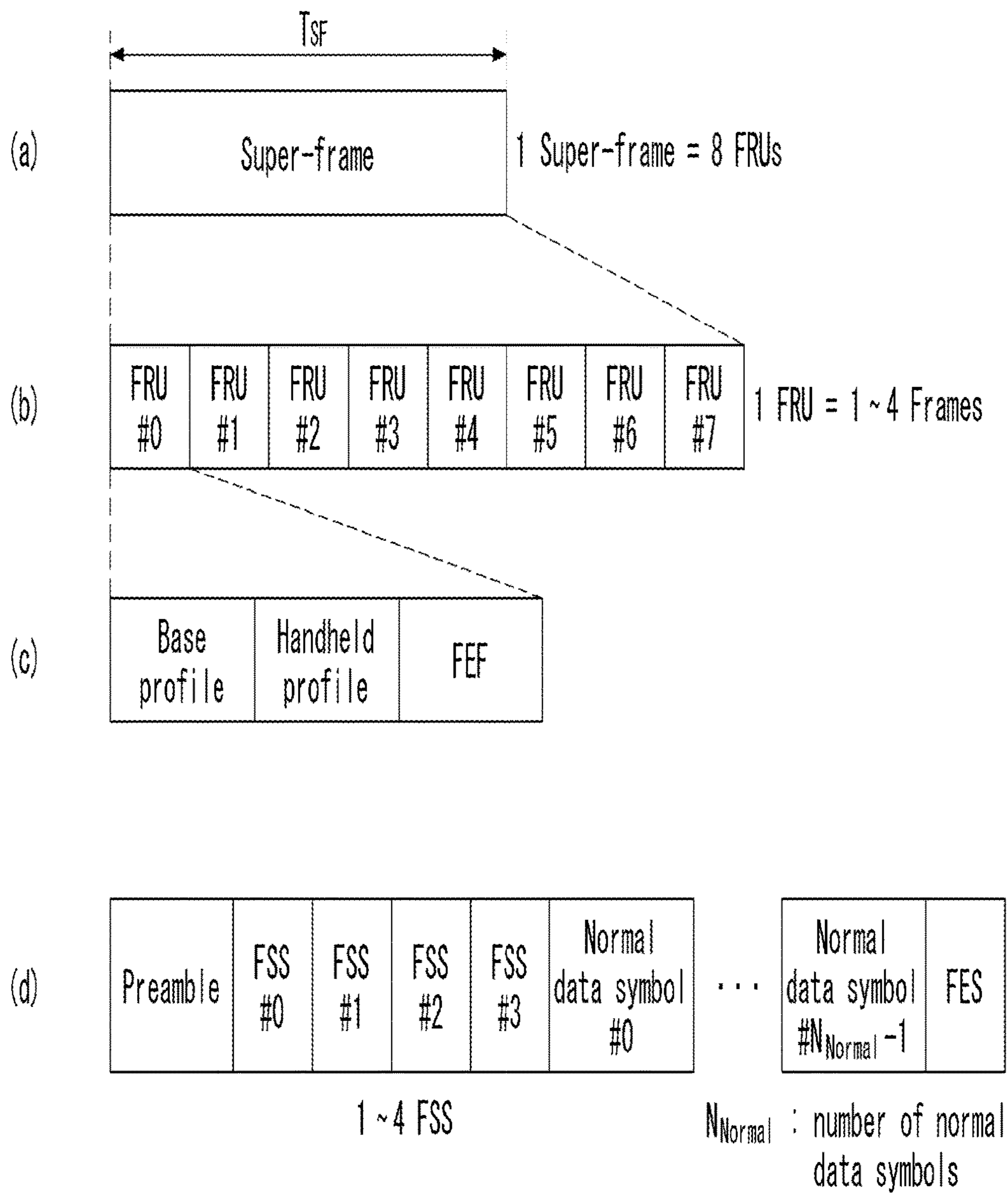

[Figure 11]

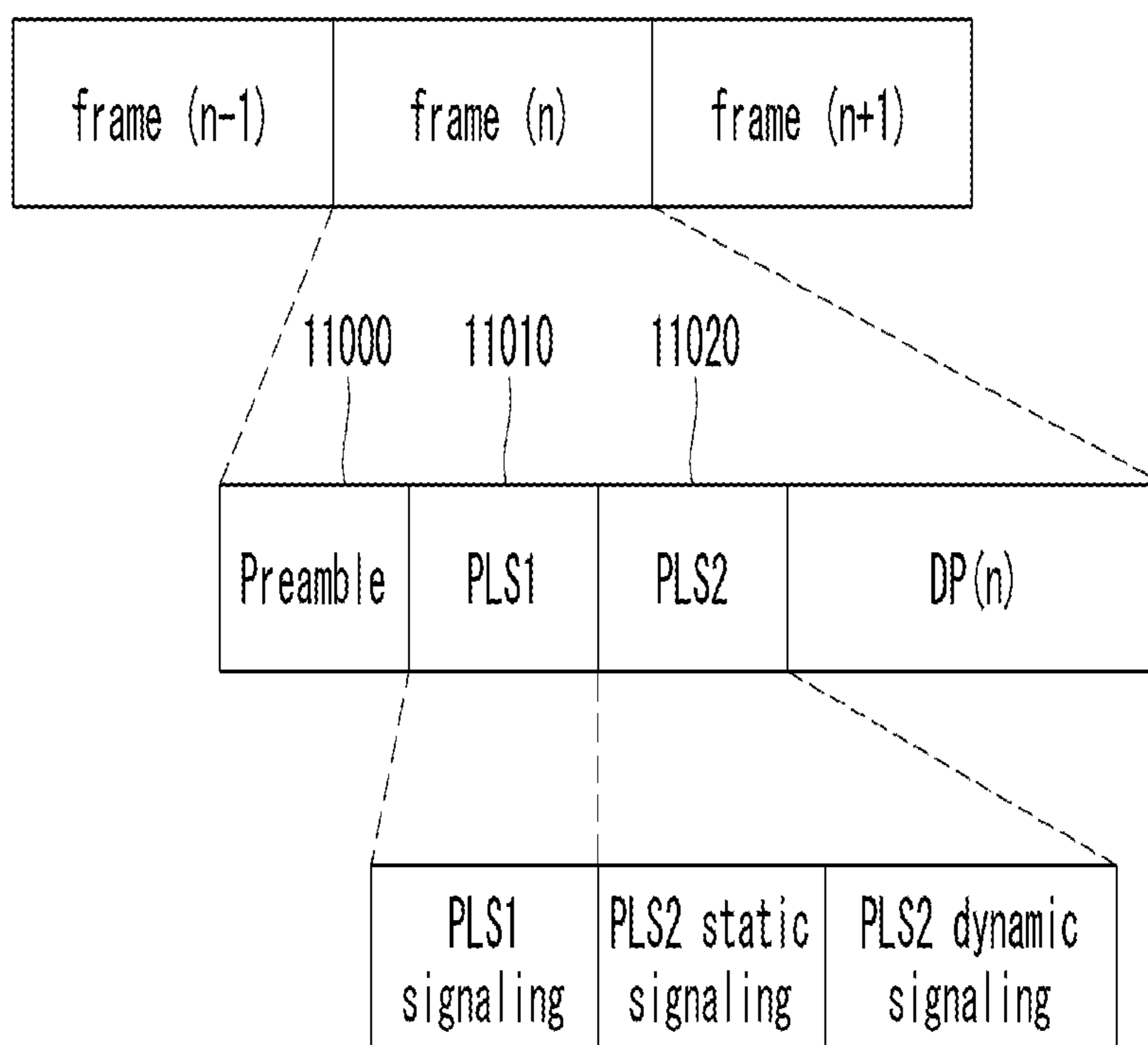

[Figure 12]

Content	Bits
PHY_PROFILE	3
FFT_SIZE	2
GI_FRACTION	3
EAC_FLAG	1
POLOT_MODE	1
PAPR_FLAG	1
FRU_CONFIGURE	3
RESERVED	7

[Figure 13]

Content	Bits
PREAMBLE_DATA	20
NUM_FRAME_FRU	2
PAYLOAD_TYPE	3
NUM_FSS	2
SYSTEM_VERSION	8
CELL_ID	16
NETWORK_ID	16
SYSTEM_ID	16
for i = 0:3	
FRU_PHY_PROFILE	3
FRU_FRAME_LENGTH	2
FRU_GI_FRACTION	3
RESERVED	4
end	
PLS2_FEC_TYPE	2
PLS2_MOD	3
PLS2_SIZE_CELL	15
PLS2_STAT_SIZE_BIT	14
PLS2_DYN_SIZE_BIT	14
PLS2_REP_FLAG	1

PLS2_REP_SIZE_CELL	15
PLS2_NEXT_FEC_TYPE	2
PLS2_NEXT_MOD	3
PLS2_NEXT_REP_FLAG	1
PLS2_NEXT_REP_SIZE_CELL	15
PLS2_NEXT_REP_STAT_SIZE_BIT	14
PLS2_NEXT_REP_DYN_SIZE_BIT	14
PLS2_AP_MODE	2
PLS2_AP_SIZE_CELL	15
PLS2_NEXT_AP_MODE	2
PLS2_NEXT_AP_SIZE_CELL	15
RESERVED	32
CRC 32	32

[Figure 14]

Content	Bit
FIC_FLAG	1
AUX_FLAG	1
NUM_DP	6
for i = NUM_DP	
DP_ID	6
DP_TYPE	3
DP_GROUP_ID	8
BASE_DP_ID	6
DP_FEC_TYPE	2
DP_COD	4
DP_MOD	4
DP_SSD_FLAG	1
if PHY_PROFILE = '010'	
DP_MIMO	3
end	
DP_TI_TYPE	1
DP_TI_LENGTH	2
DP_TI_BYPASS	1
DP_FRAME_INTERVAL	2
DP_FIRST_FRAME_IDX	5
DP_NUM_BLOCK_MAX	10
DP_PAYLOAD_TYPE	2
DP_INBAND_MODE	2
DP_PROTOCOL_TYPE	2
DP_CRC_MODE	2

if DP_PAYLOAD_TYPE==TS('00')	
DNP_MODE	2
ISSY_MODE	2
HC_MODE_TS	2
if HC_MODE_TS=='01' or '10'	
PID	13
end	
if DP_PAYLOAD_TYPE==IP('01')	
HC_MODE_IP	2
end	
RESERVED	8
end	
if FIC_FLAG == 1	
FIC_VERSION	8
FIC_LENGTH_BYTE	13
RESERVED	8
end	
if AUX_FLAG == 1	
NUM_AUX	4
AUX_CONFIG_RFU	8
for i=1:NUM_AUX	
AUX_STREAM_TYPE	4
AUX_PRIVATE_CONF	28
end	
end	

[Figure 15]

Content	Bit
FRAME_INDEX	5
PLS_CHANGE_COUNTER	4
FIC_CHANGE_COUNTER	4
RESERVED	16
for i = 1:NUM_DP	
DP_ID	6
DP_START	15 (or 13)
DP_NUM_BLOCK	10
RESERVED	8
end	
EAC_FLAG	1
EAS_WAKE_UP_VERSION_NUM	8
if EAC_FLAG == 1	
EAC_LENGTH_BYTE	12
else	
EAC_COUNTER	12
end	
for i = 1:NUM_AUX	
AUX_PRIVATE_DYN	48
end	
CRC	32

[Figure 16]



[Figure 17]

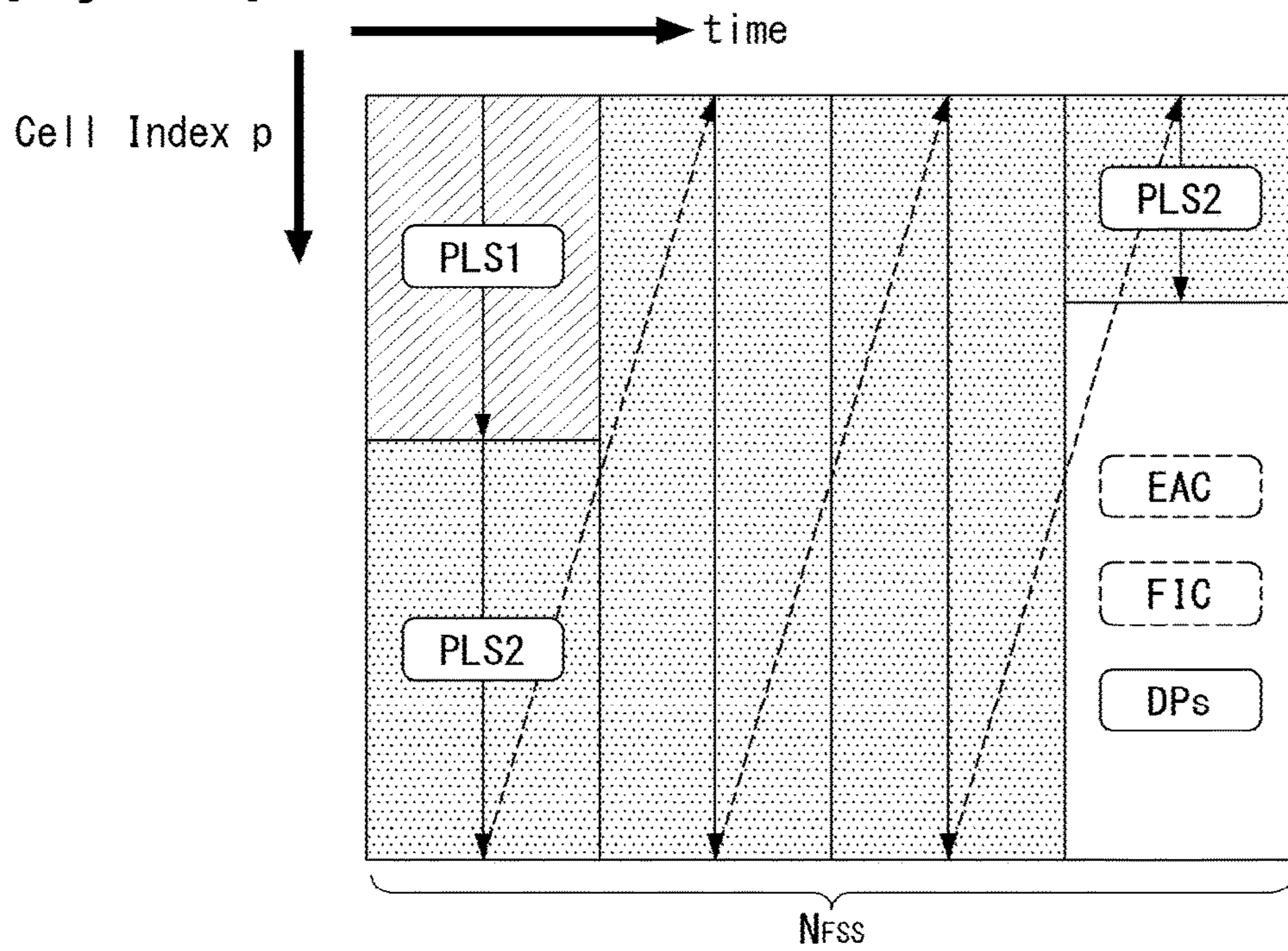

[Figure 18]

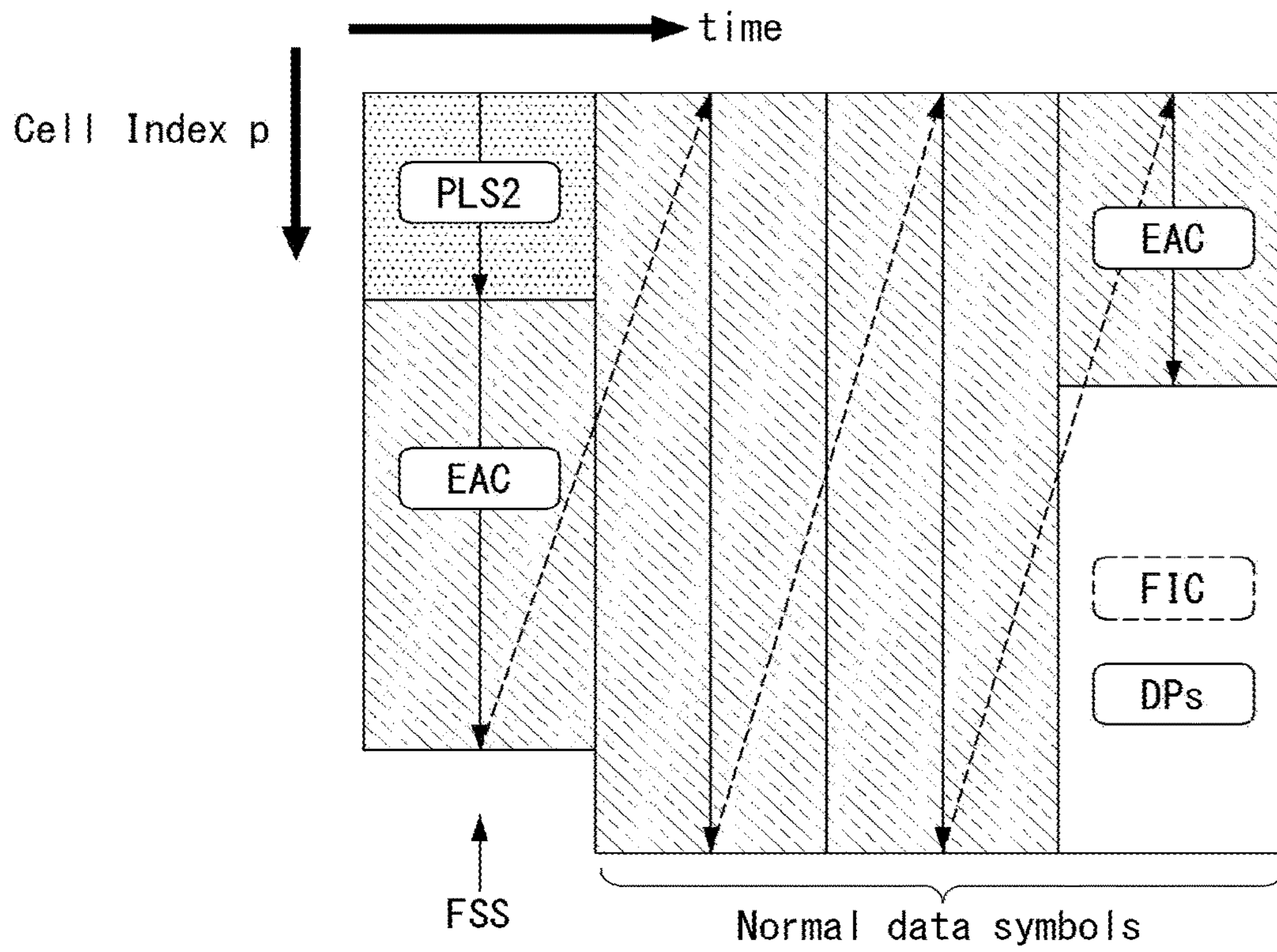

[Figure 19]

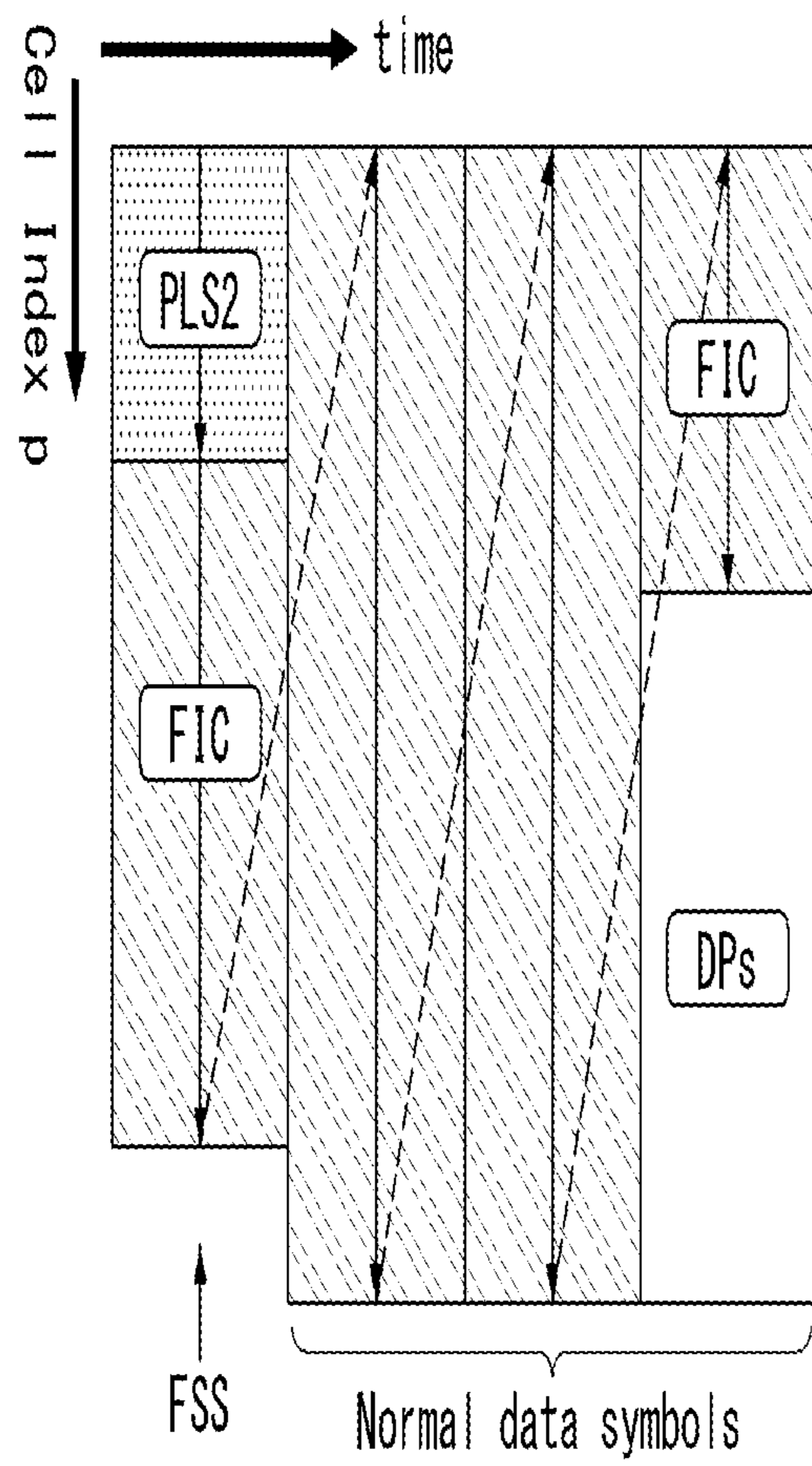

(a)

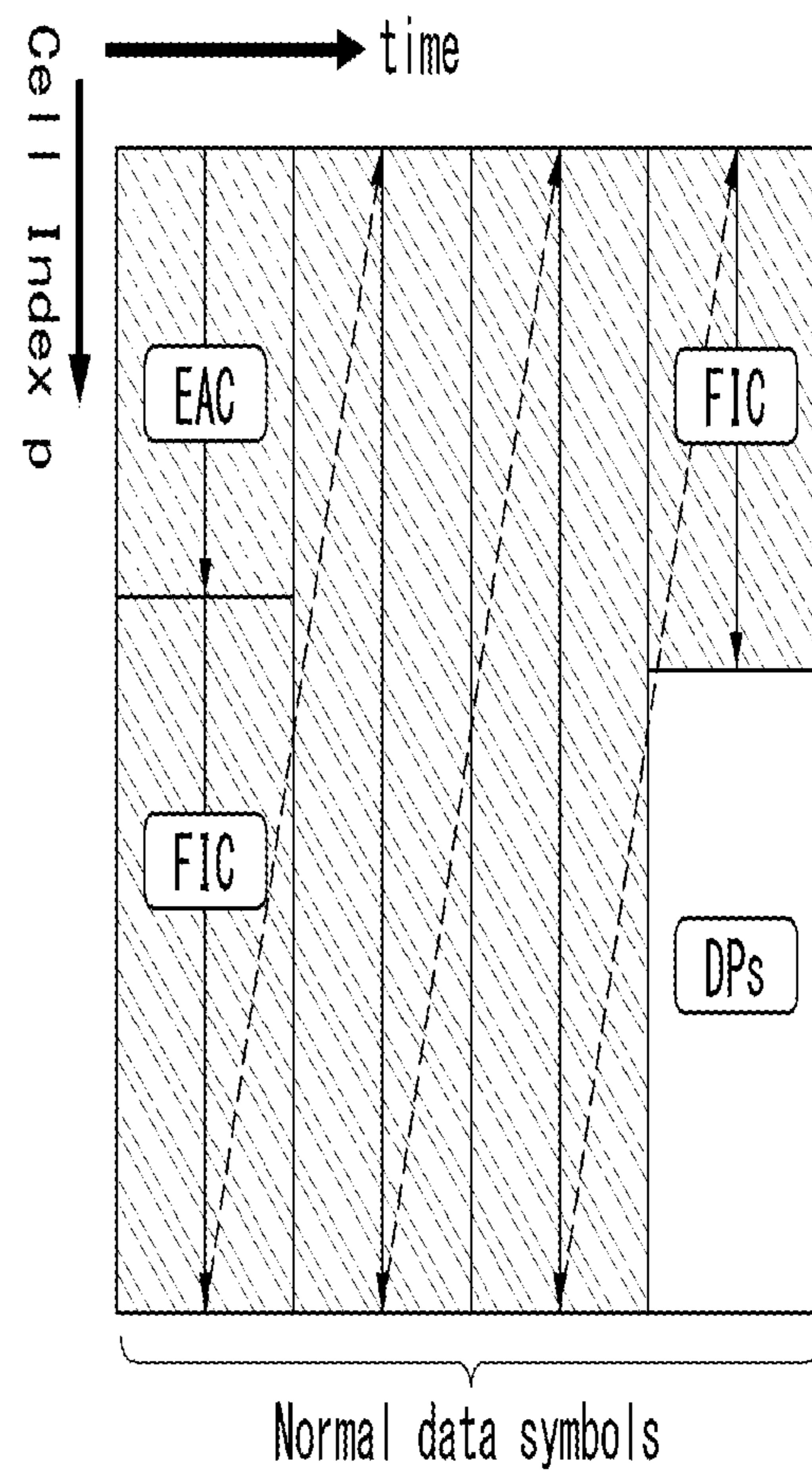

(b)

[Figure 20]

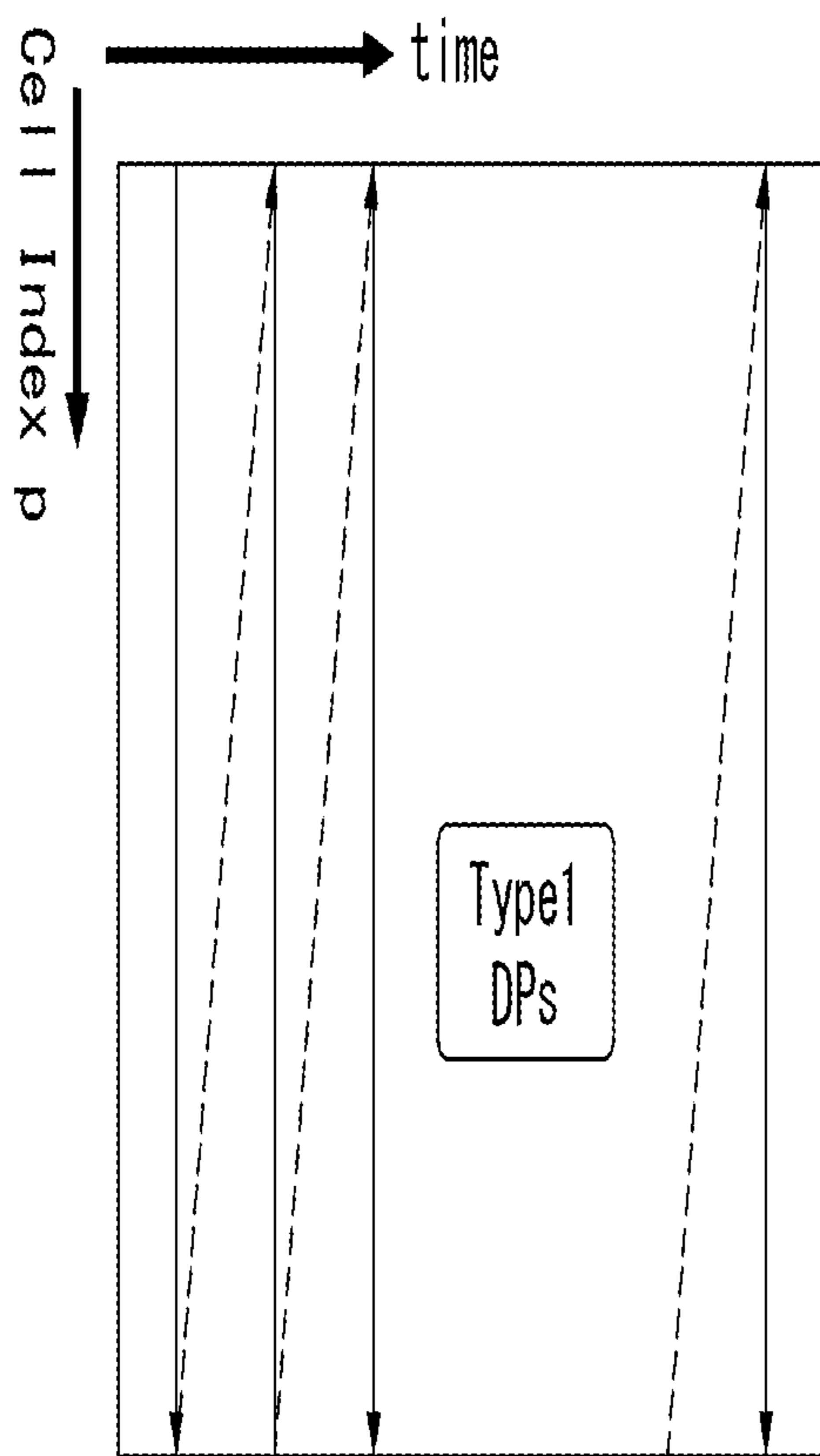

(a)

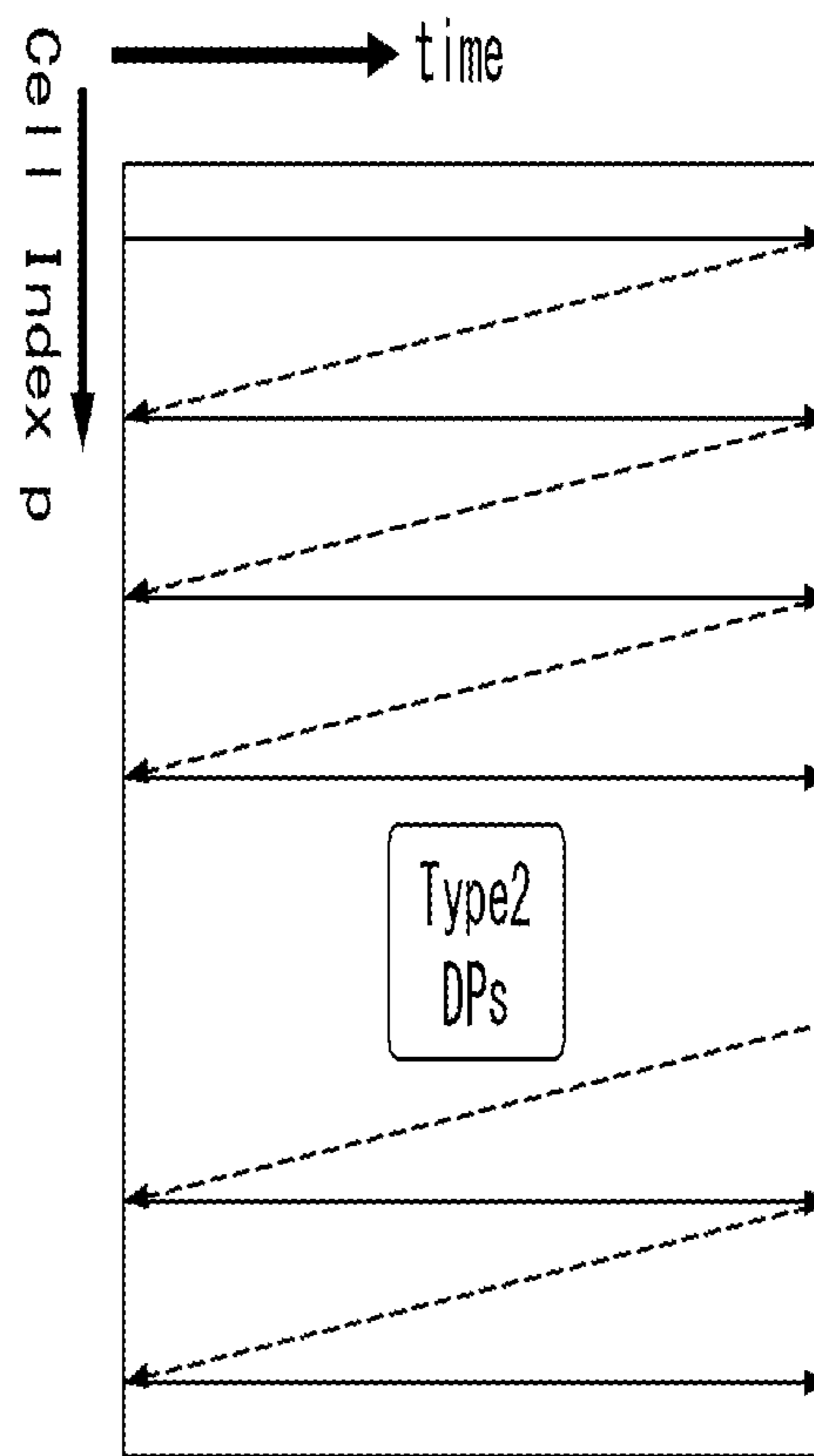

(b)

[Figure 21]

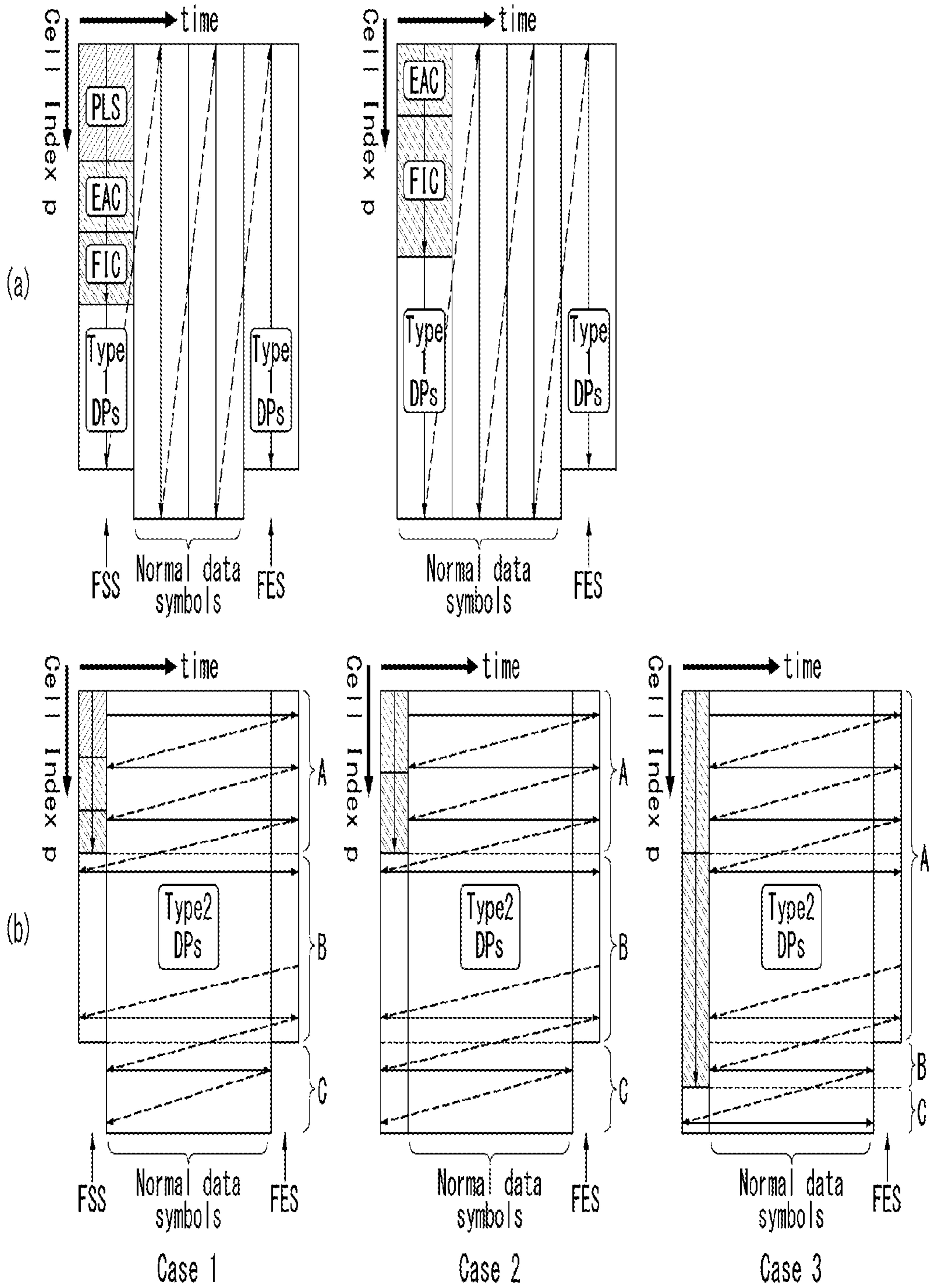

[Figure 22]

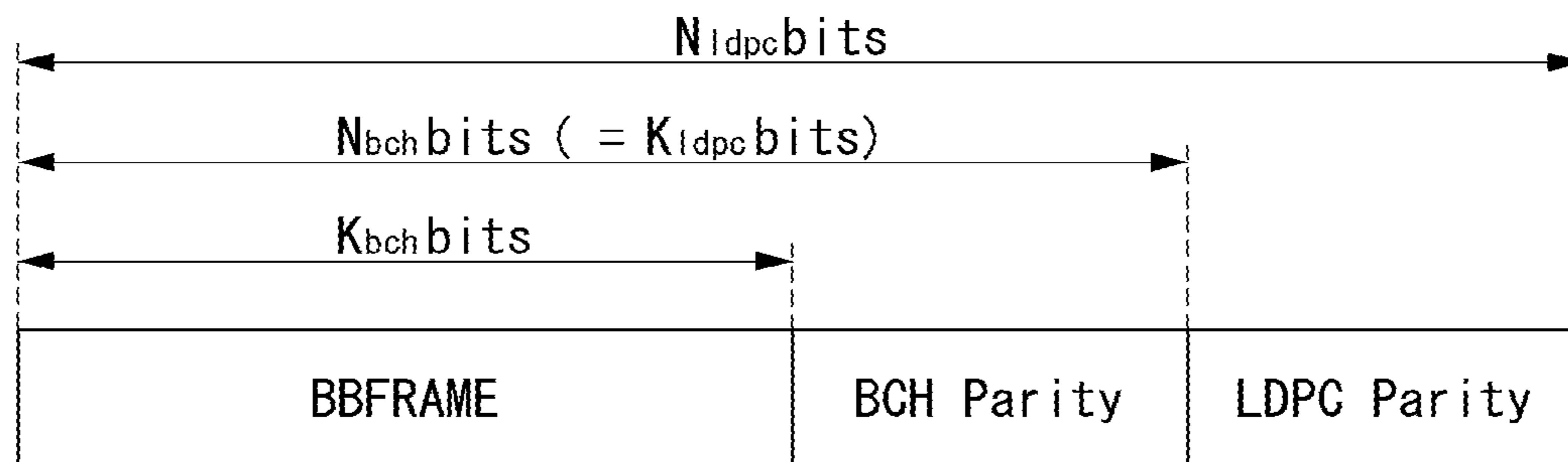

[Figure 23]

$$N_{QCB} = \begin{cases} 45, & \text{for short LDPC block} \\ 180, & \text{for long LDPC block} \end{cases}$$

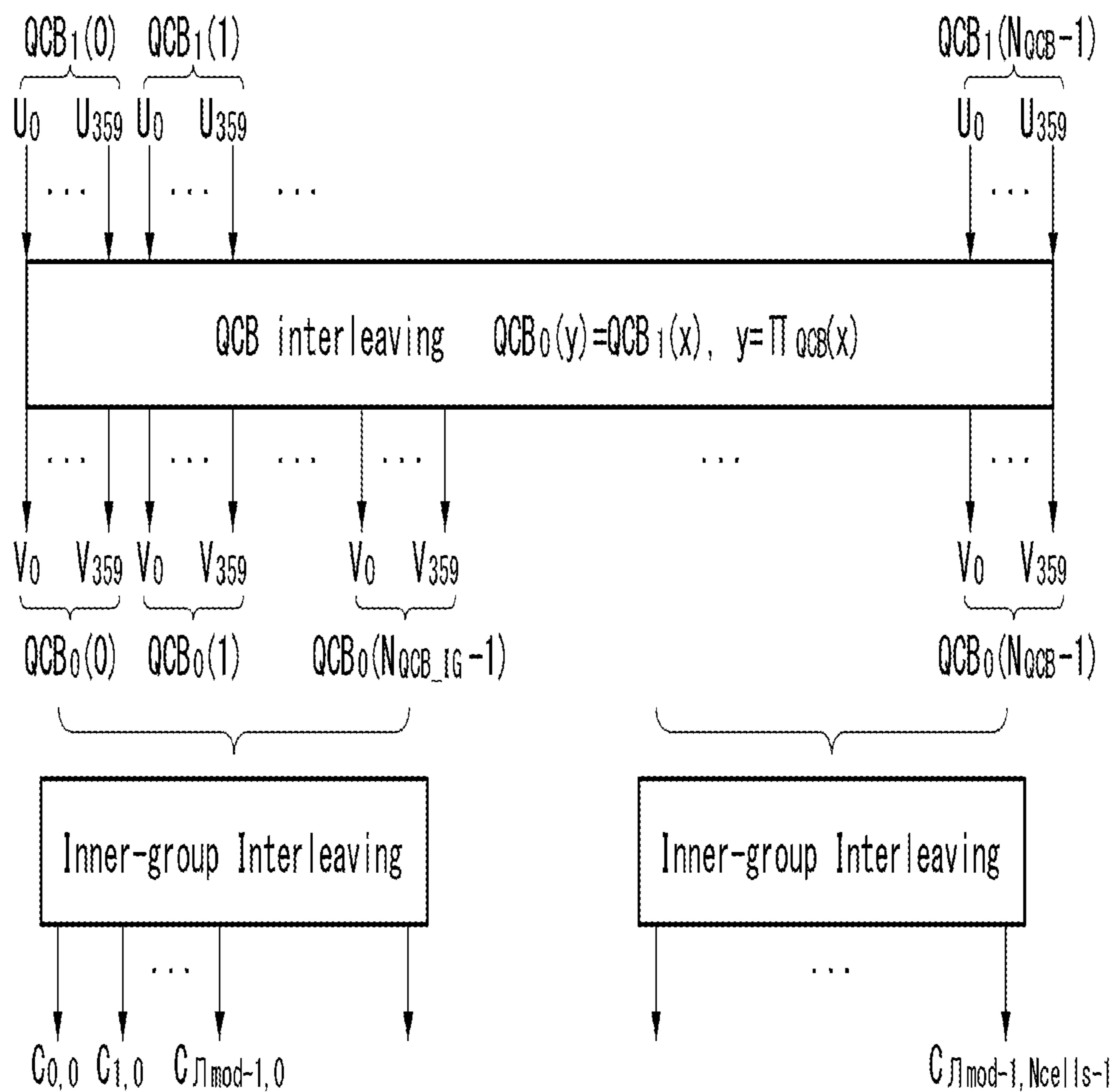

[Figure 24]

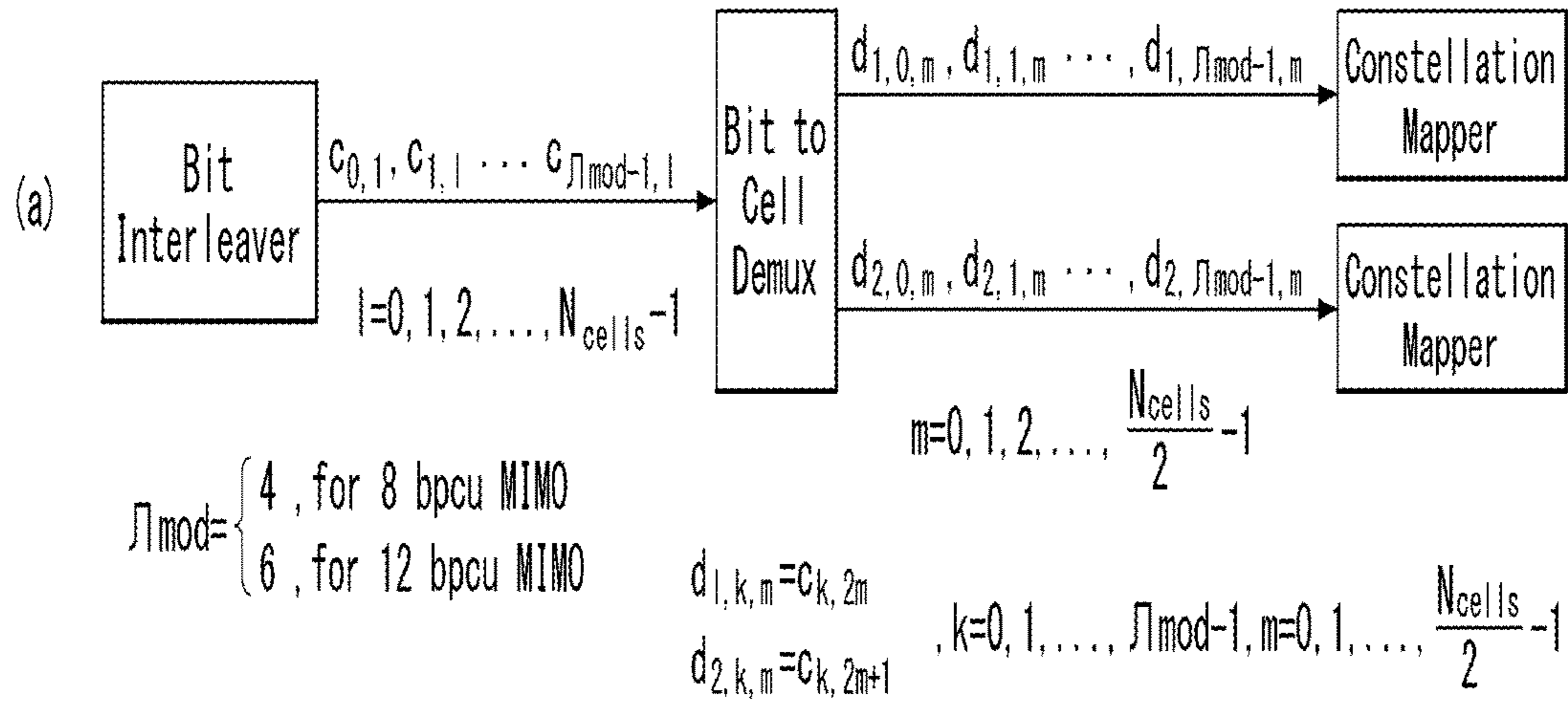

$\Lambda_{mod}=10$, for 10 bpcu MIMO

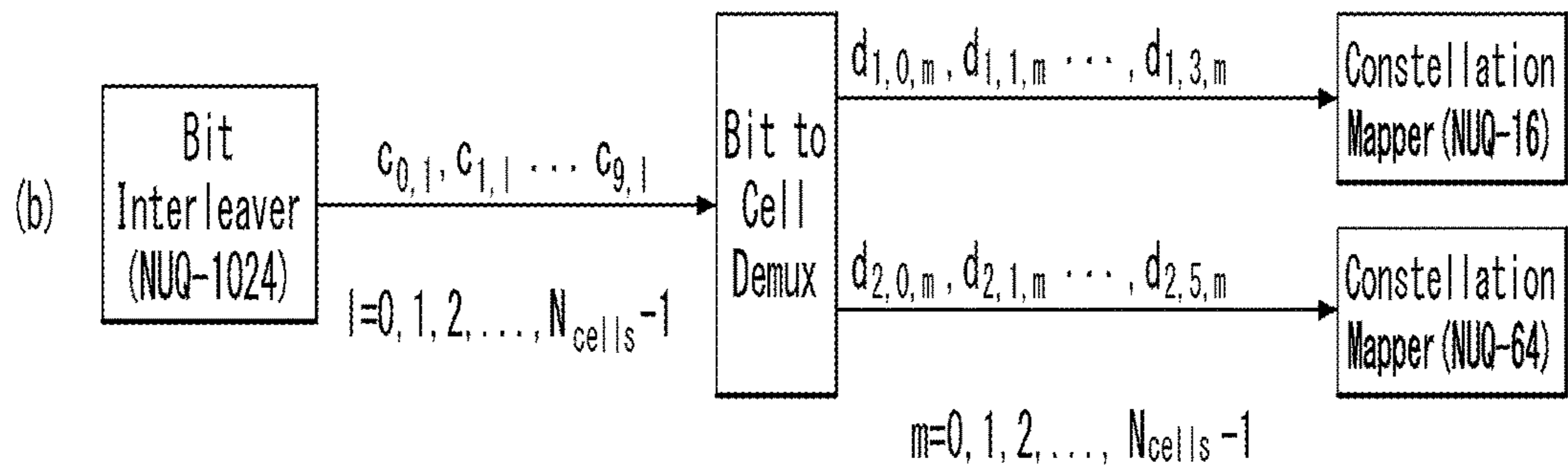

[Figure 25]

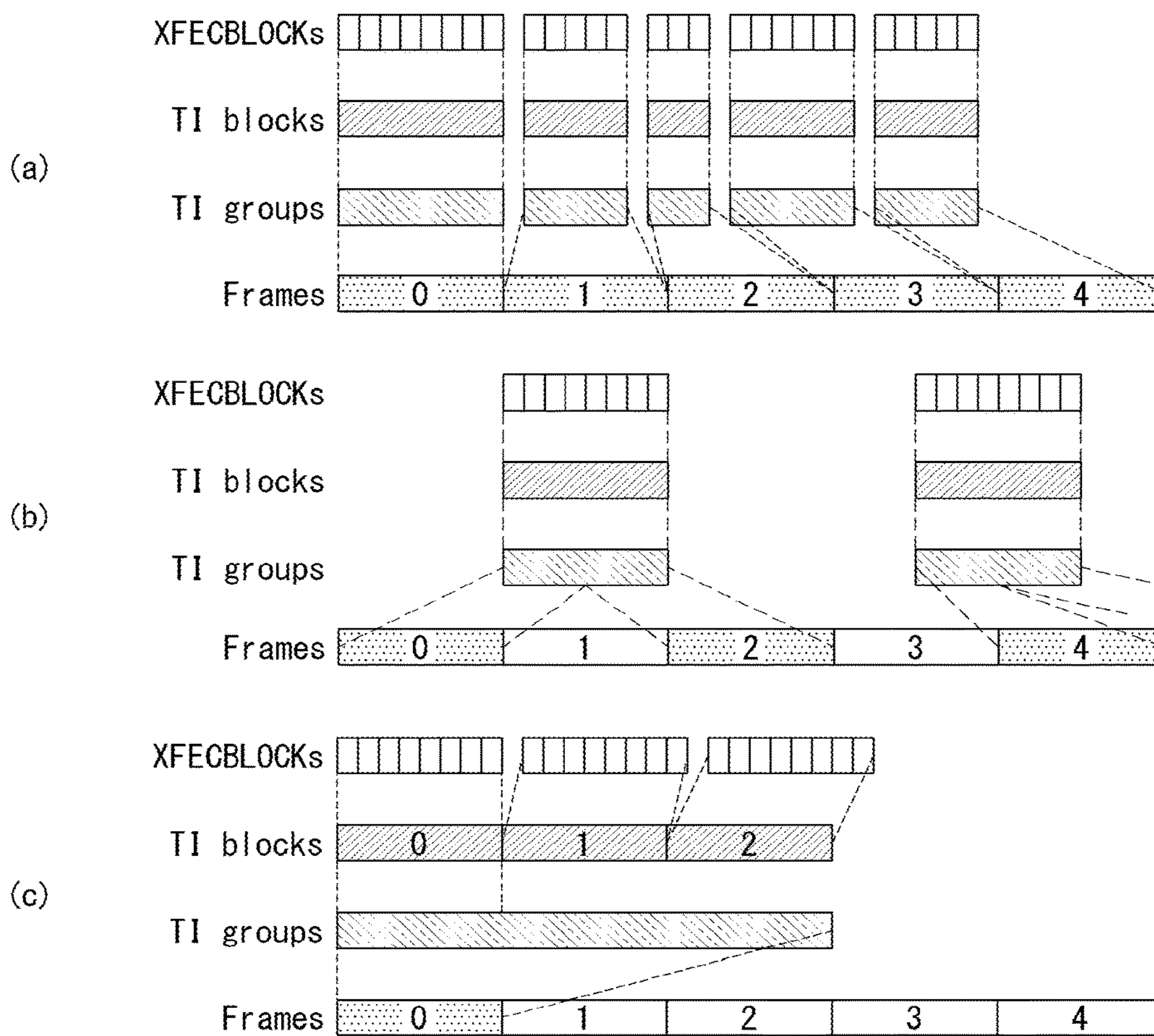

[Figure 26]

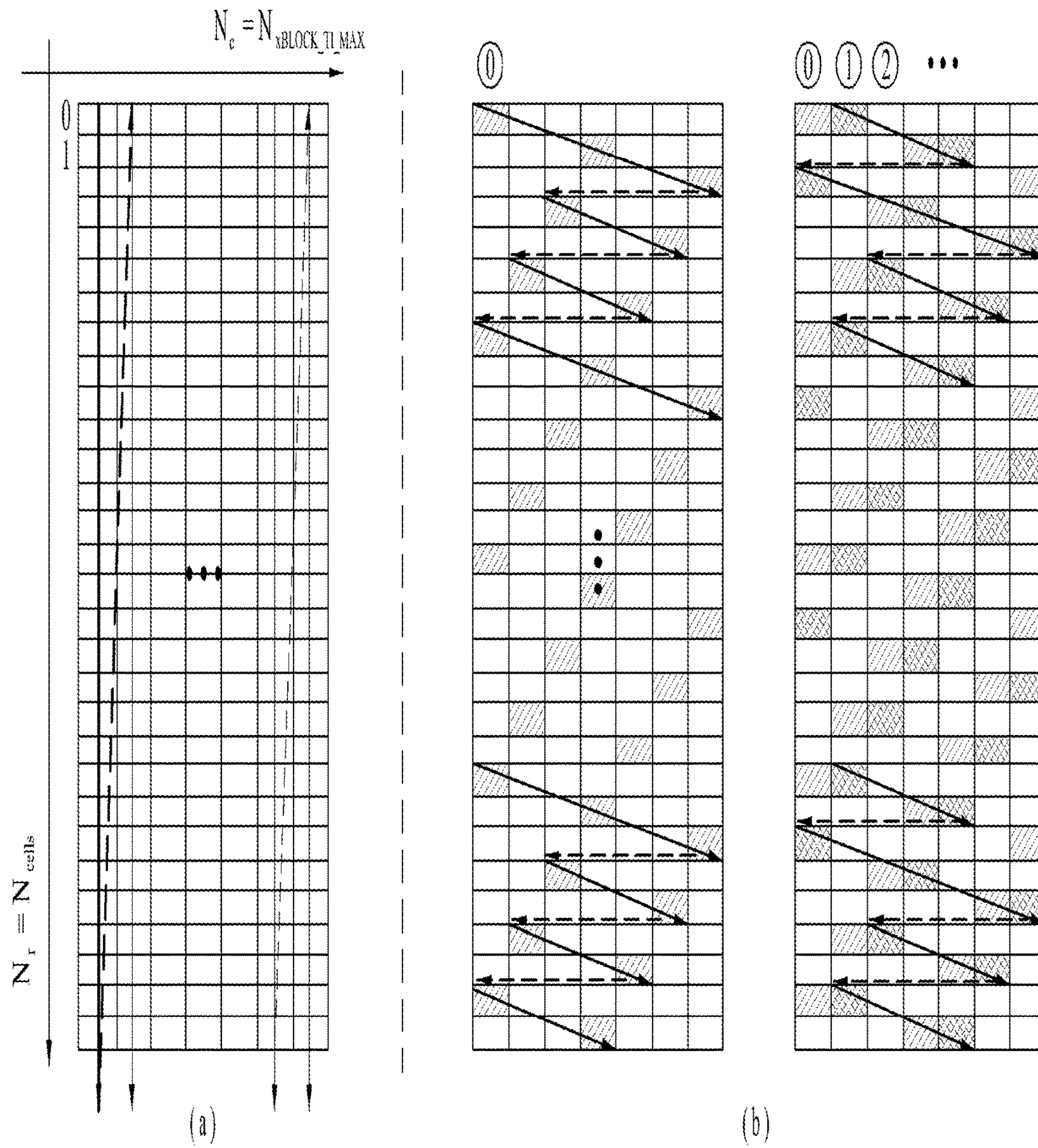

[Figure 27]

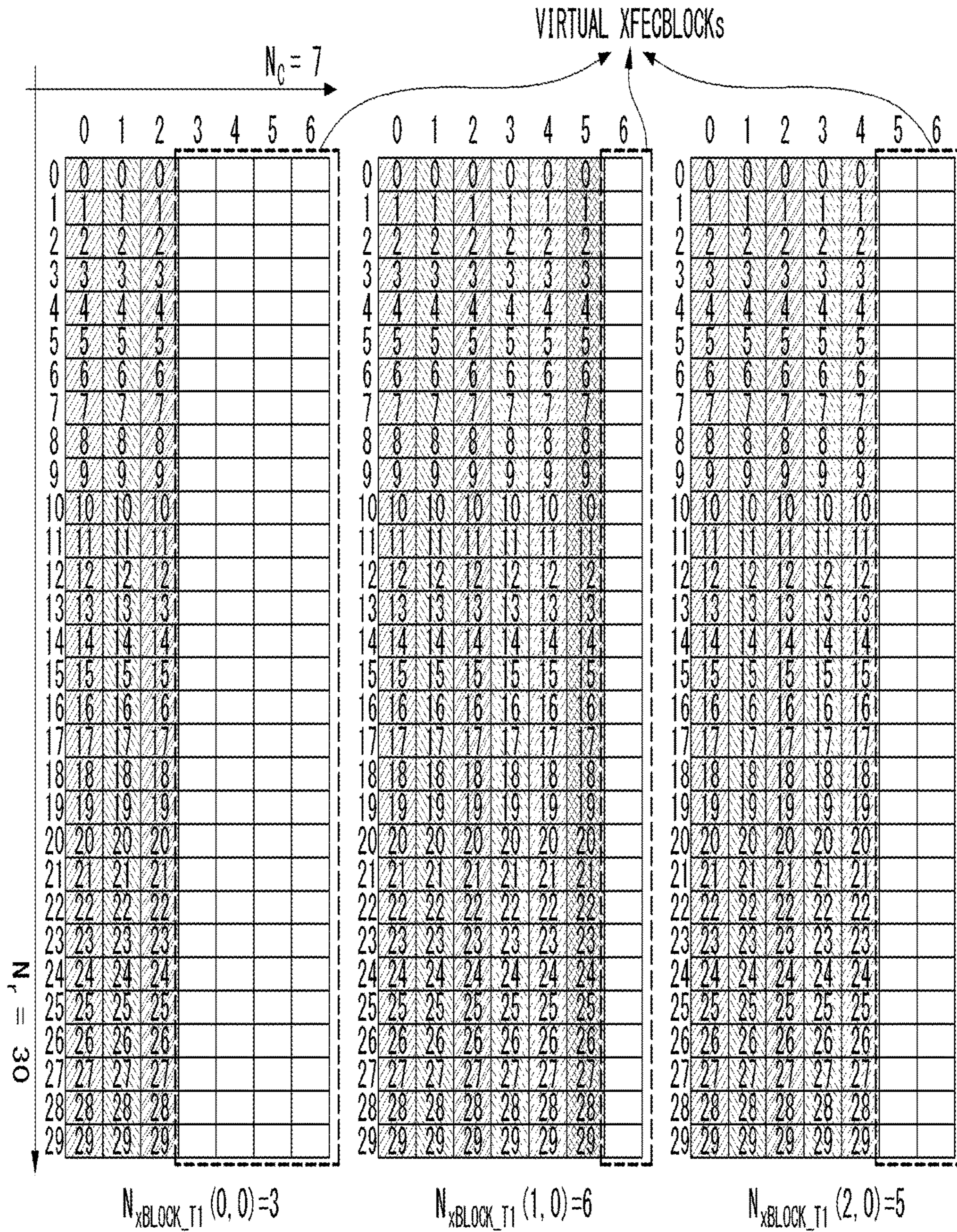

[Figure 28]

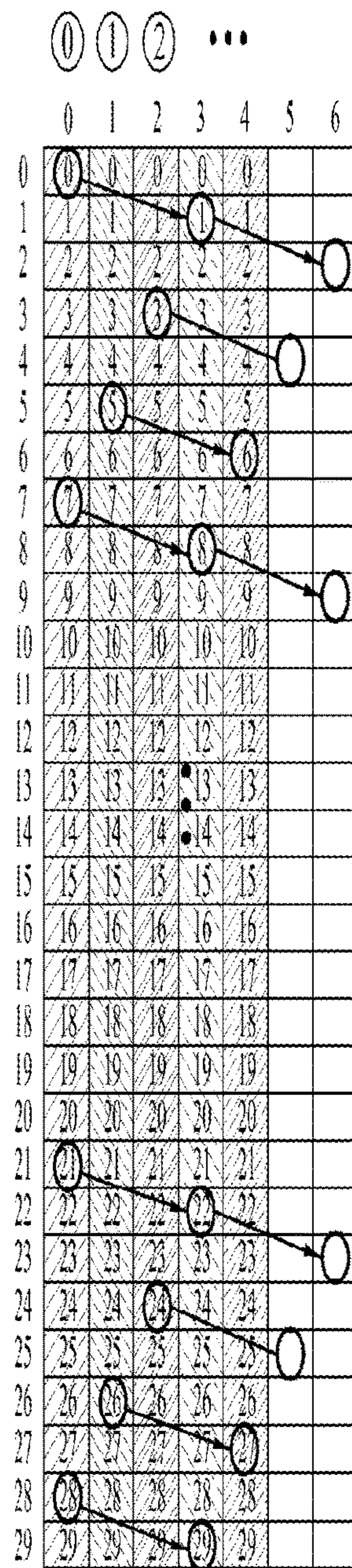
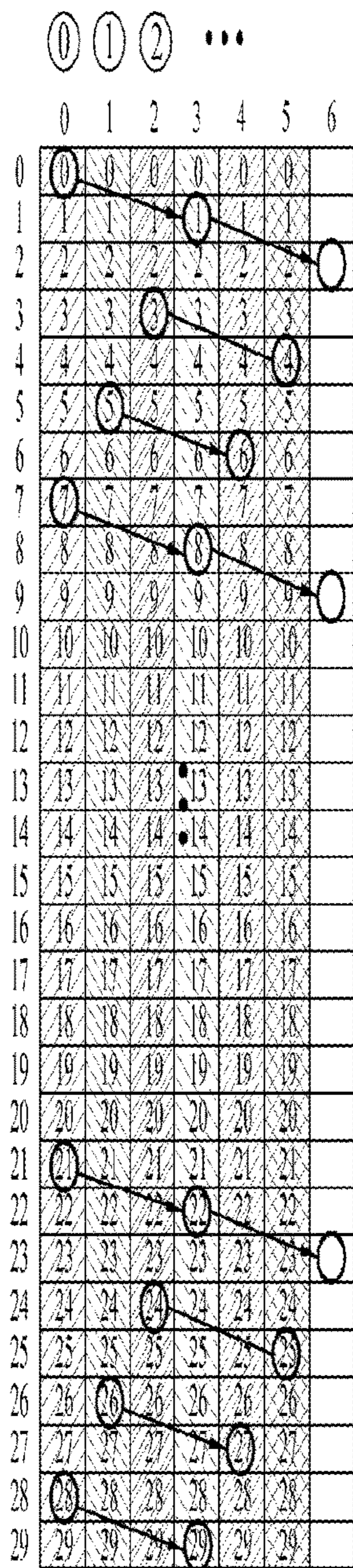
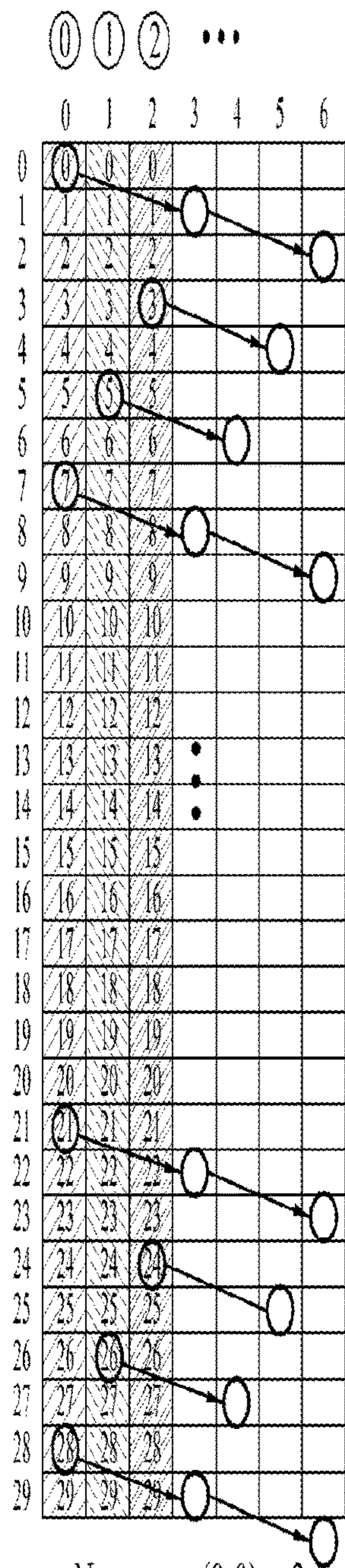

[Figure 29]

	0	1	2
0	0	4	22
1	3	11	25
2	5	14	27
3	7	16	29
4	10	18	1
5	12	21	3
6	14	23	6
7	17	25	8
8	19	28	10
9	21	2	13
10	24	4	15
11	26	6	17
12	28	9	20
13	0	11	22
14	2	13	24
15	5	16	27
16	7	18	29
17	9	20	1
18	12	23	3
19	14	25	5
20	16	27	8
21	19	1	10
22	21	4	12
23	23	6	15
24	26	8	17
25	28	11	19
26	0	13	22
27	2	15	24
28	4	18	26
29	7	20	29

$$N_{xBLOCK_TI}(0,0) = 3$$

	0	1	2	3	4	5
0	0	5	9	14	20	24
1	1	6	10	16	21	25
2	3	7	11	17	22	27
3	4	8	12	18	23	28
4	5	9	14	19	25	29
5	6	10	15	20	26	1
6	7	12	16	21	27	2
7	8	13	17	23	28	3
8	10	14	18	24	29	4
9	11	15	19	25	0	5
10	12	16	21	26	1	6
11	13	17	22	27	2	8
12	14	19	23	28	3	9
13	15	20	24	0	4	10
14	17	21	25	1	6	11
15	18	22	26	2	7	12
16	19	23	28	4	8	13
17	20	24	29	5	9	15
18	21	26	0	6	10	16
19	22	27	2	7	11	17
20	24	28	3	8	13	18
21	25	29	4	9	14	19
22	26	0	5	1	15	20
23	27	1	6	12	16	22
24	28	2	7	13	17	23
25	29	3	9	14	18	24
26	0	4	10	15	20	25
27	1	5	11	16	21	26
28	2	7	12	18	22	27
29	3	8	13	19	23	29

$$N_{xBLOCK_TI}(1,0) = 6$$

	0	1	2	3	4
0	0	10	23	6	17
1	1	12	24	7	18
2	3	14	25	8	20
3	5	15	26	9	22
4	6	16	28	11	23
5	7	17	0	13	24
6	8	19	2	14	25
7	10	21	4	15	27
8	12	22	5	16	29
9	13	23	6	18	1
10	14	24	7	20	3
11	15	26	9	21	4
12	17	28	11	22	5
13	19	29	12	23	6
14	20	0	13	25	8
15	21	2	14	27	10
16	22	3	16	28	11
17	24	4	18	29	12
18	26	5	19		13
19	27	7	20	2	15
20	28	9	21	3	17
21	29	10	23	4	18
22	0	11	25	6	19
23	1	12	26	8	20
24	2	14	27	9	22
25	3	16	28	10	24
26	5	17	0	11	25
27	7	18	1	13	26
28	8	19	2	15	27
29	9	21	4	16	29

$$N_{xBLOCK_TI}(2,0) = 5$$

[Figure 30]

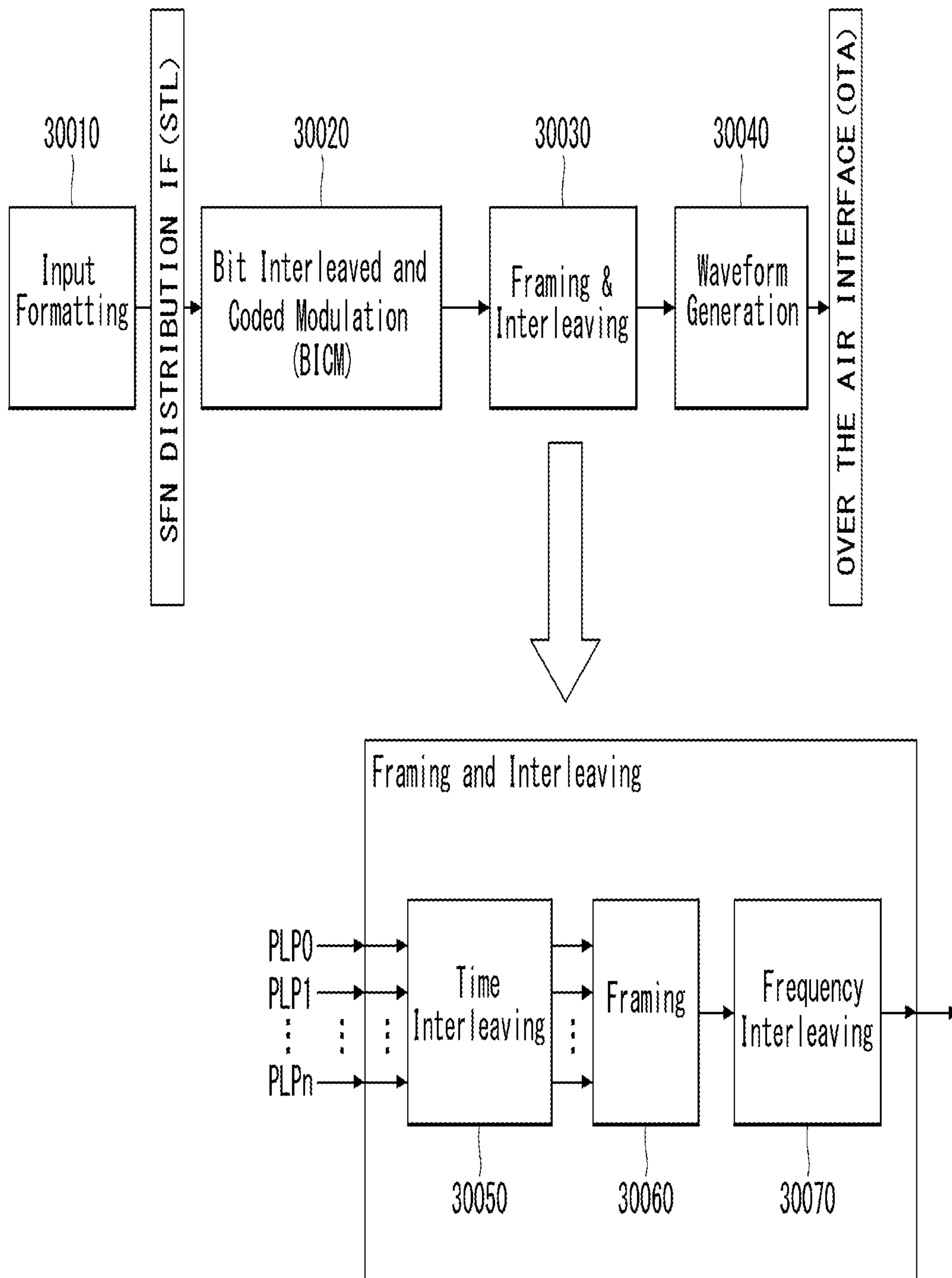

[Figure 31]

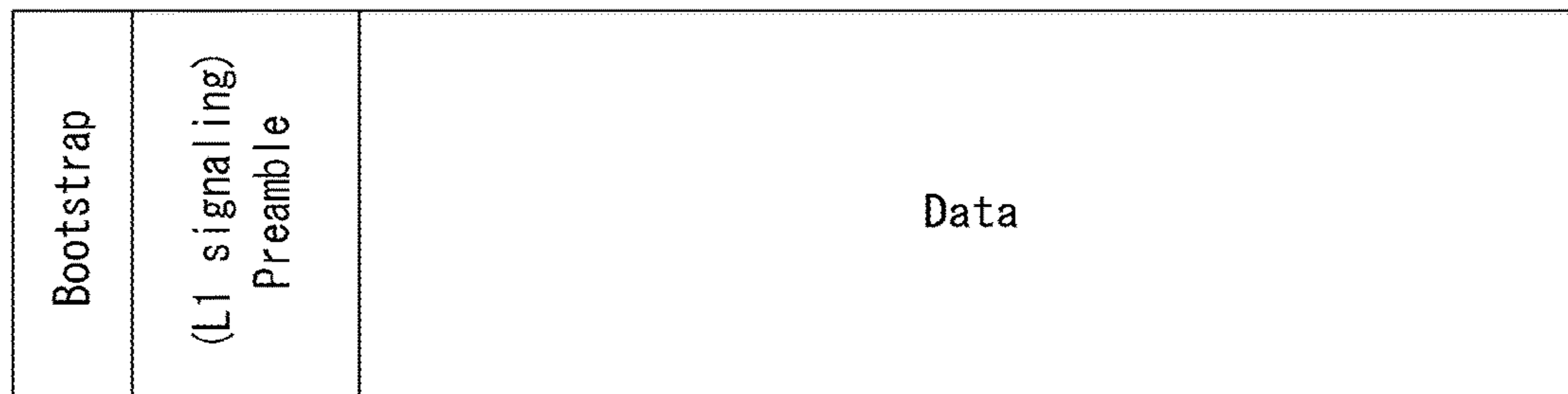

[Figure 32]

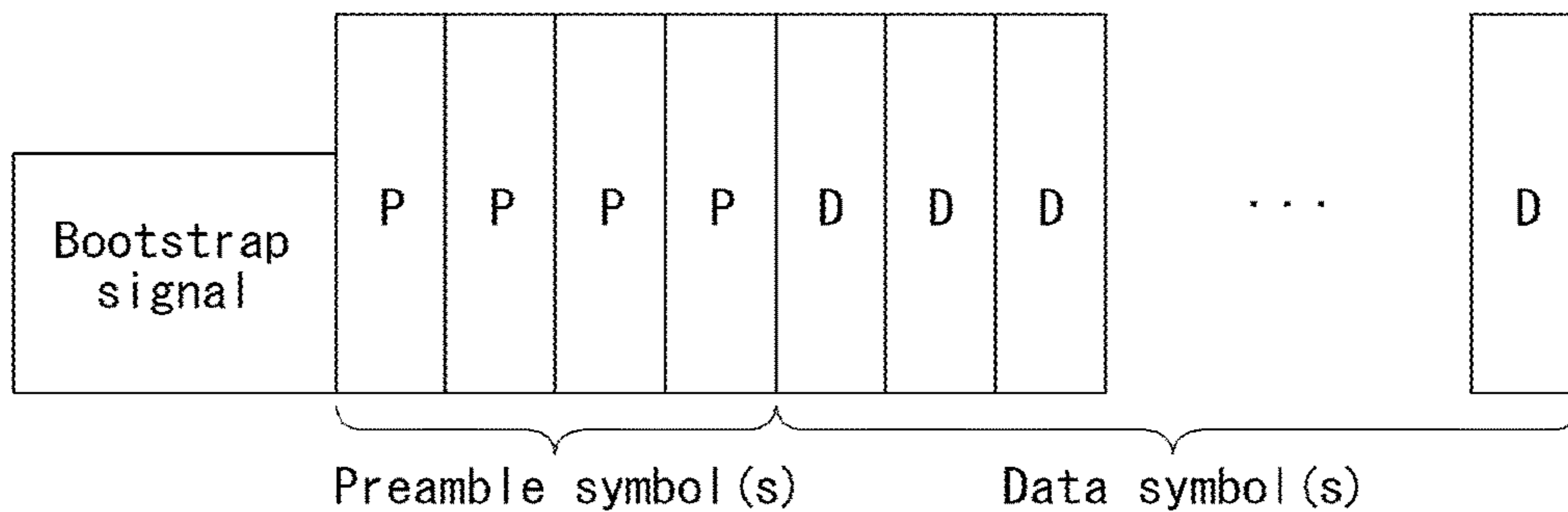

[Figure 33]

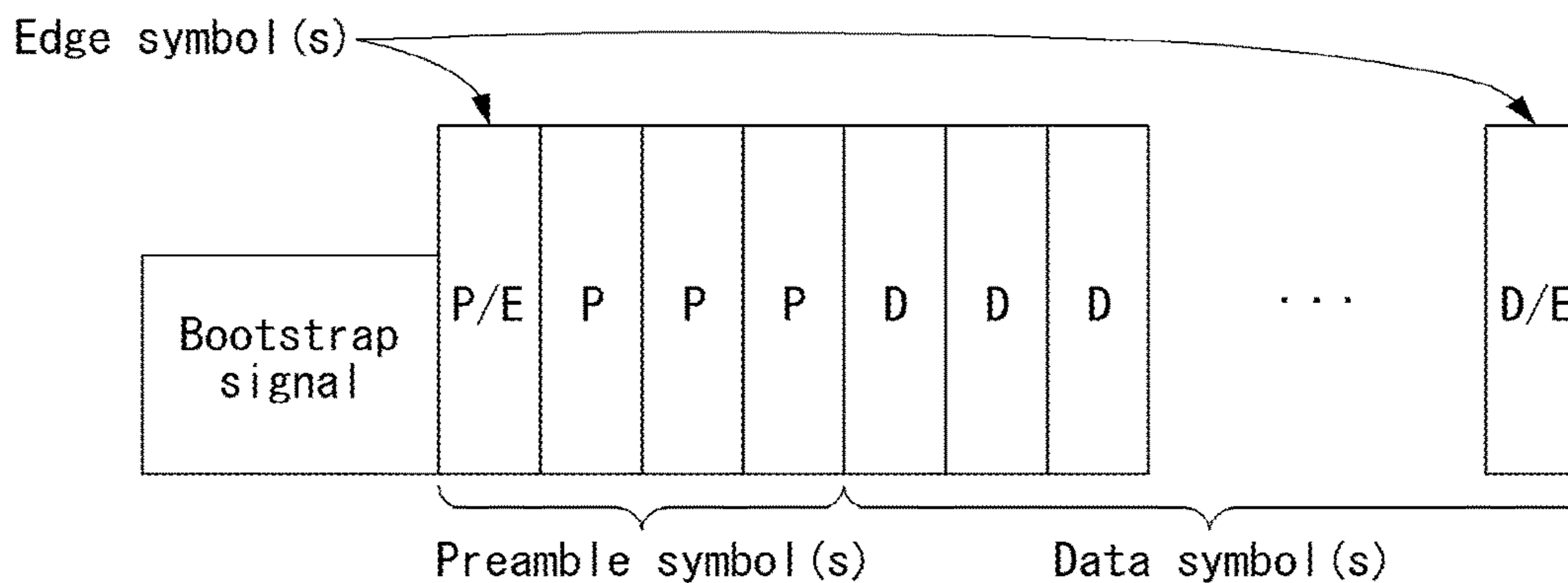

[Figure 34]

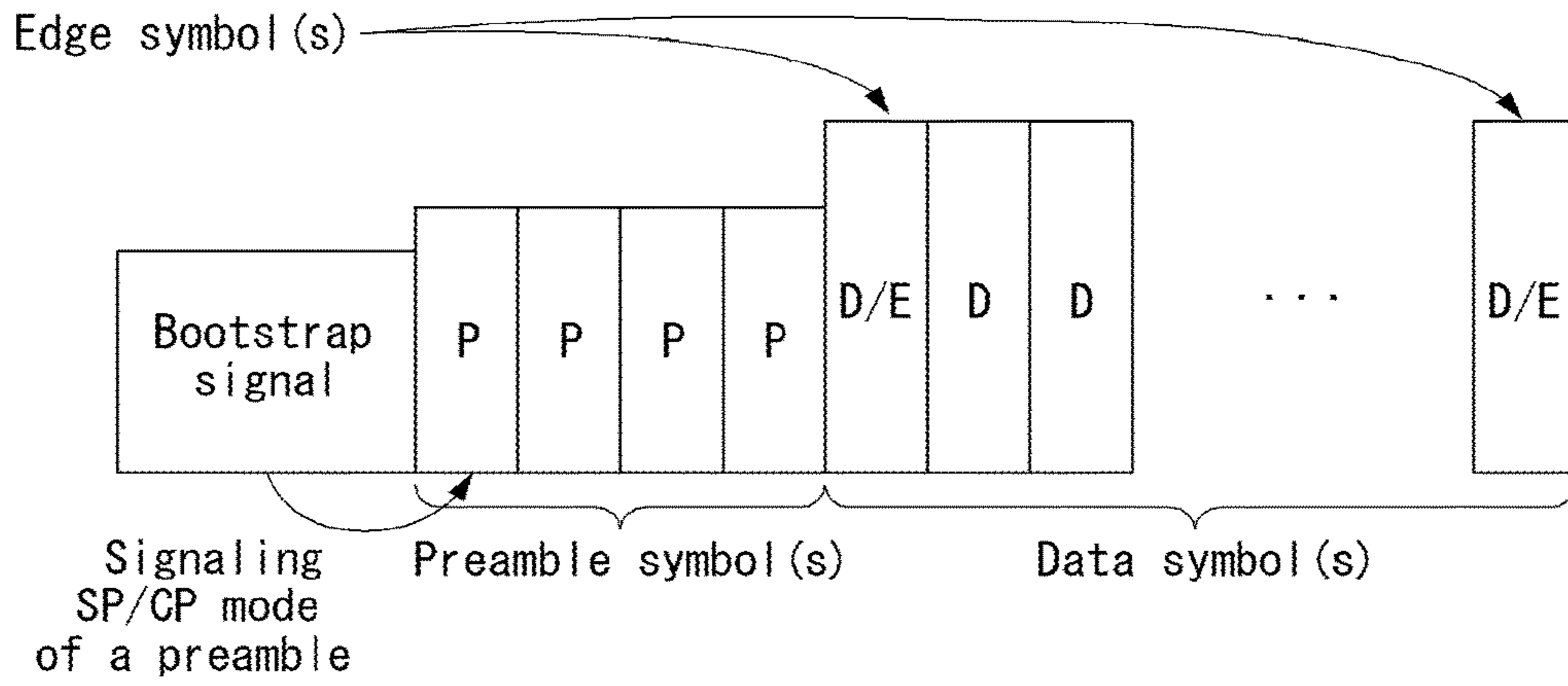

[Figure 35]

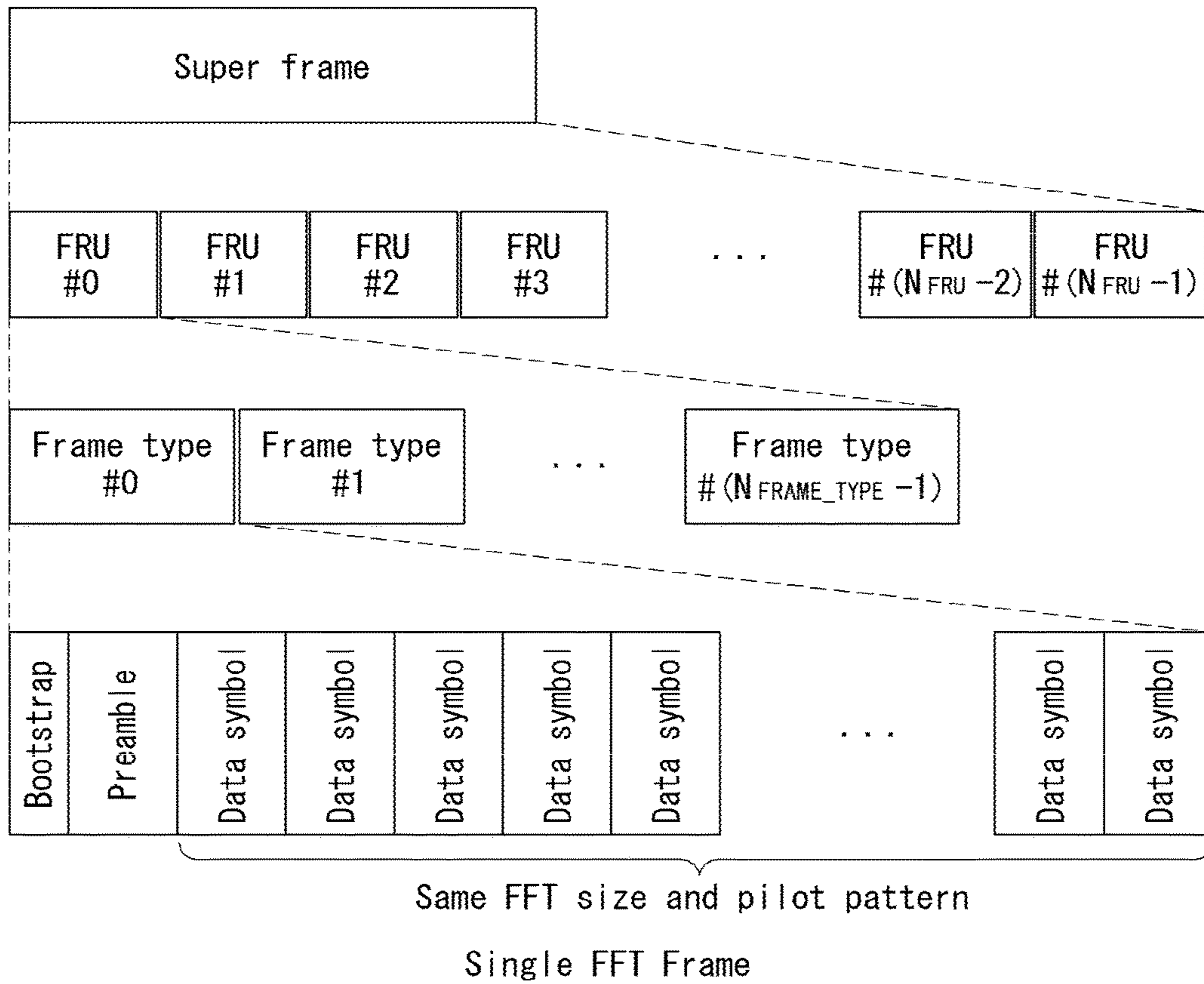

[Figure 36]

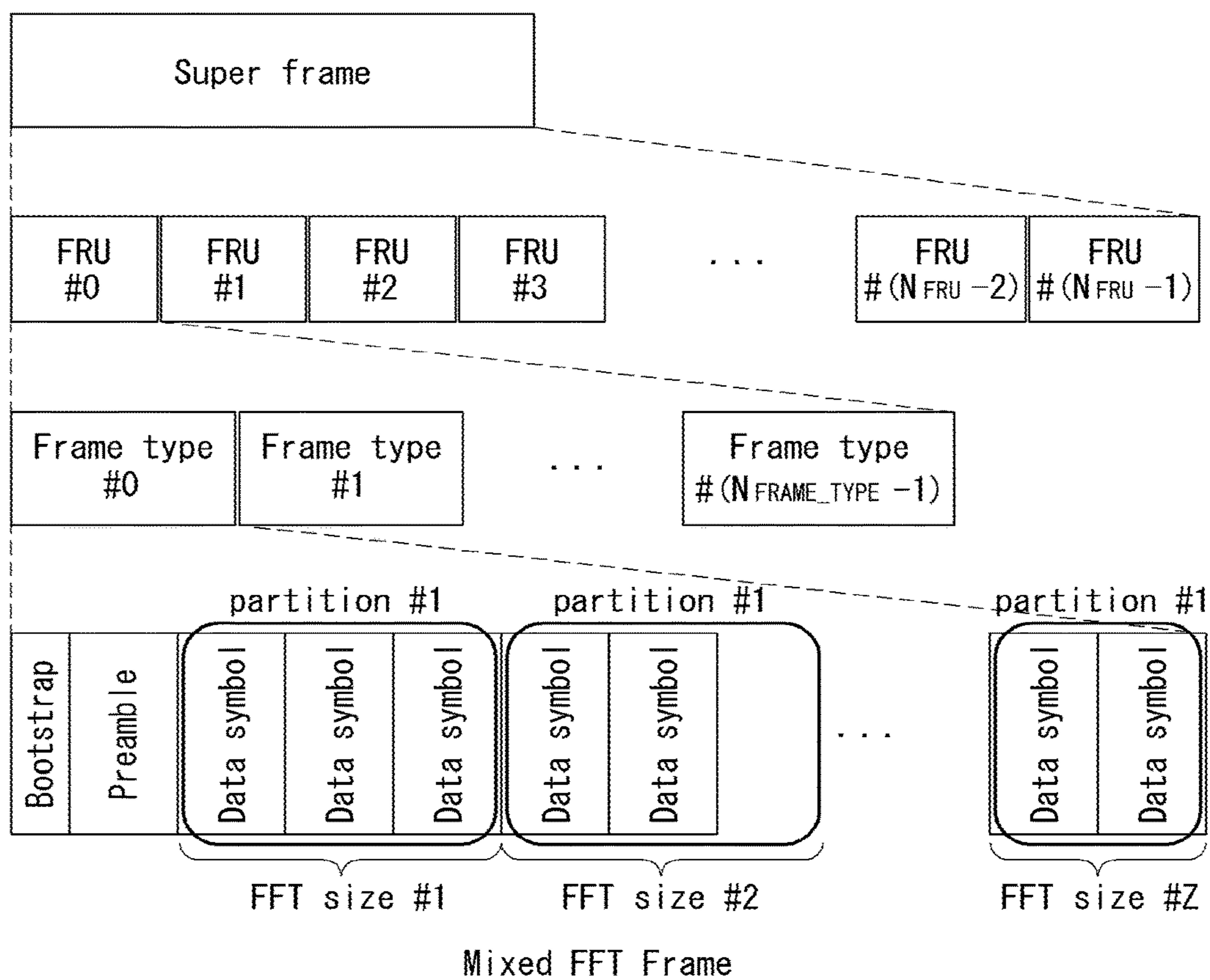

[Figure 37]

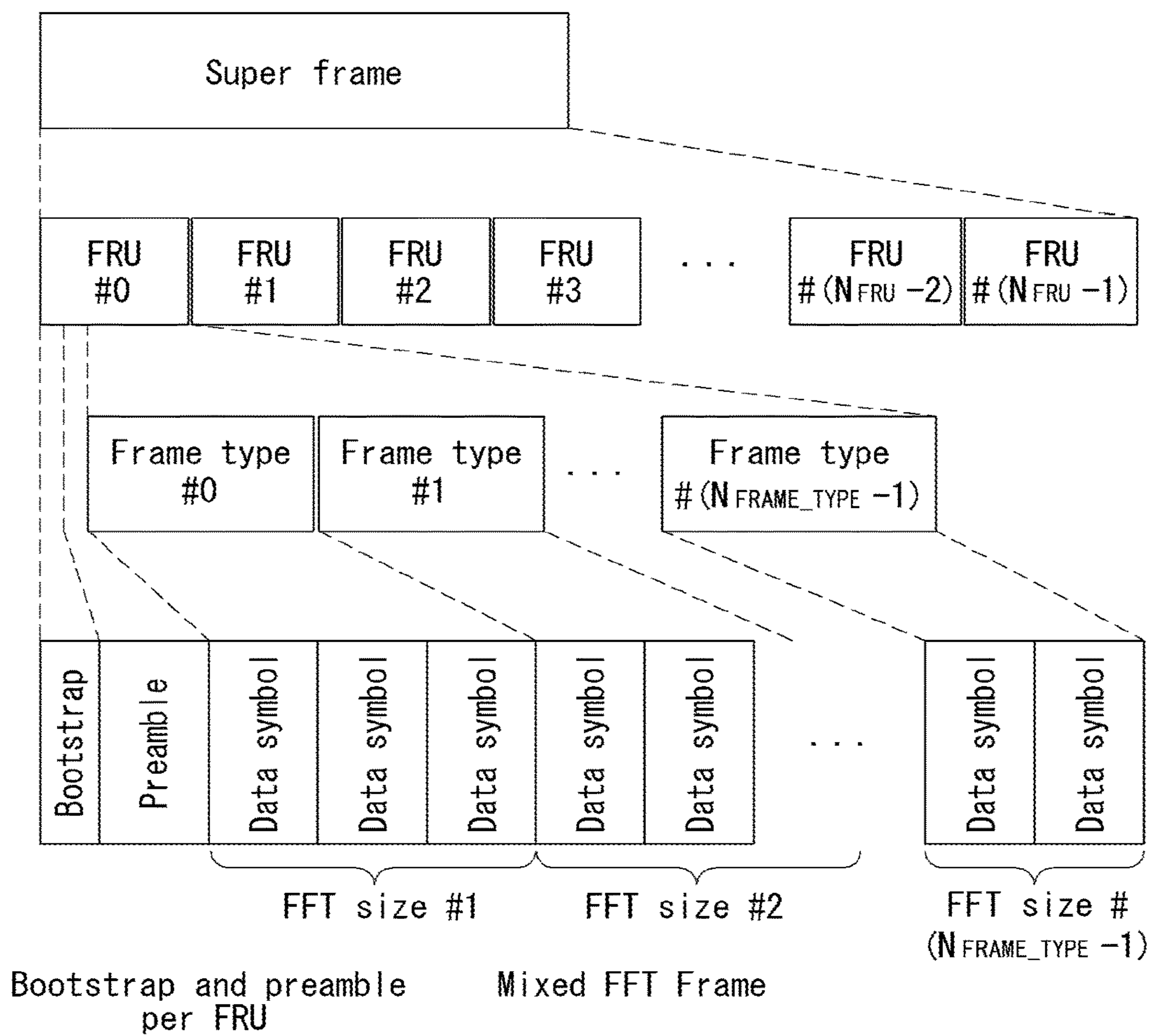

[Figure 38]

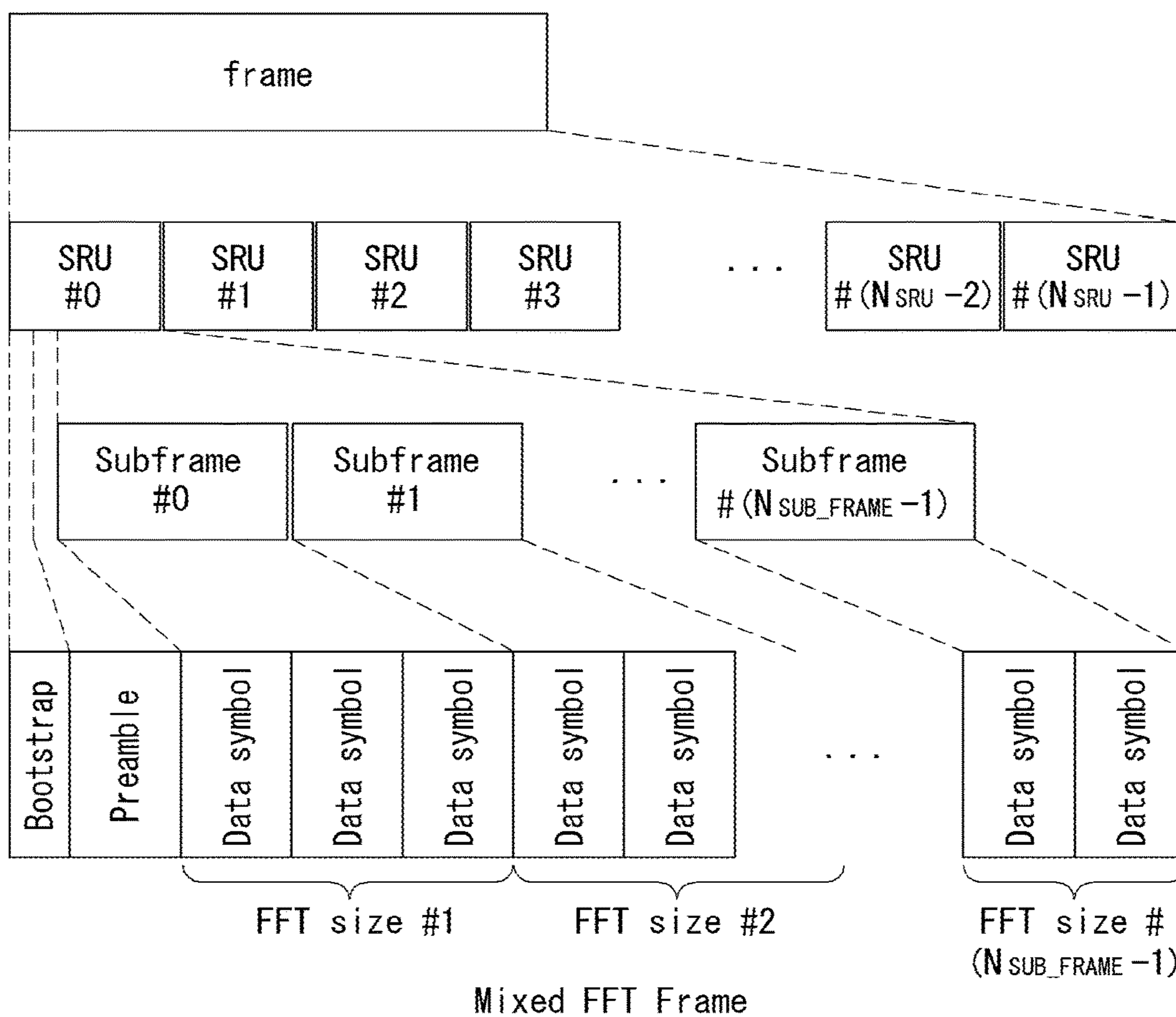

[Figure 39]

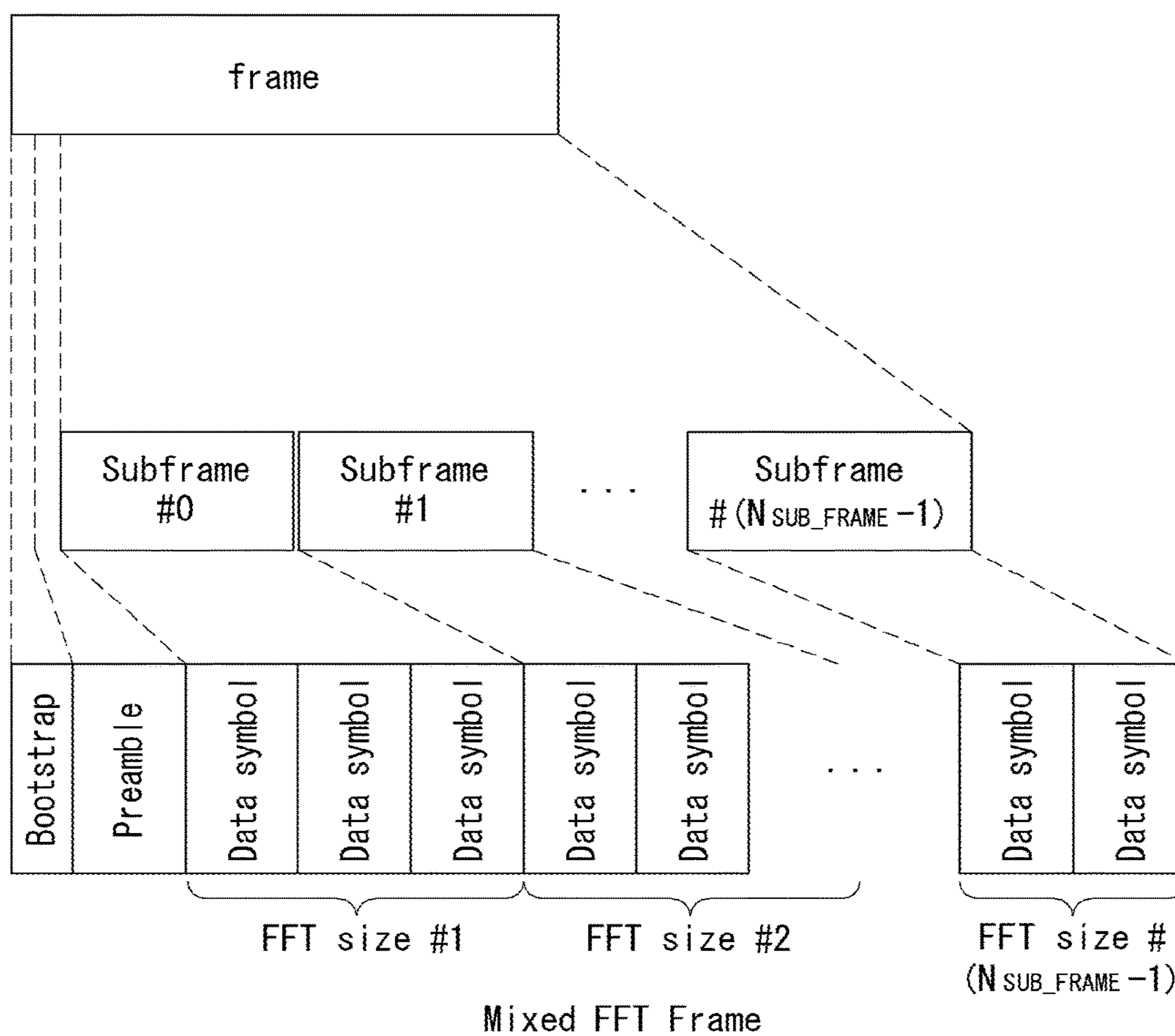

[Figure 40]

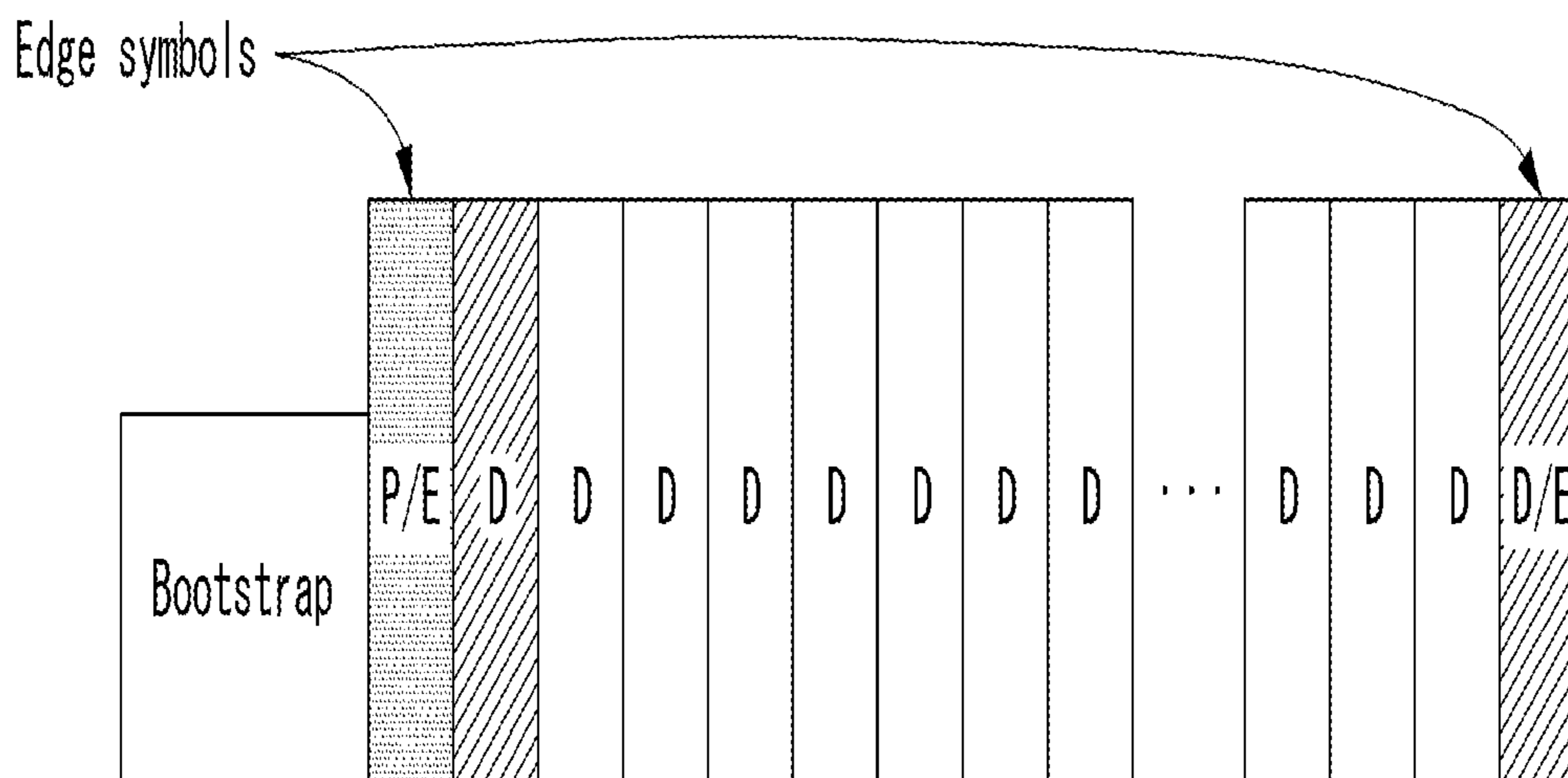

(a) Two edge symbols per frame for a single FFT frame

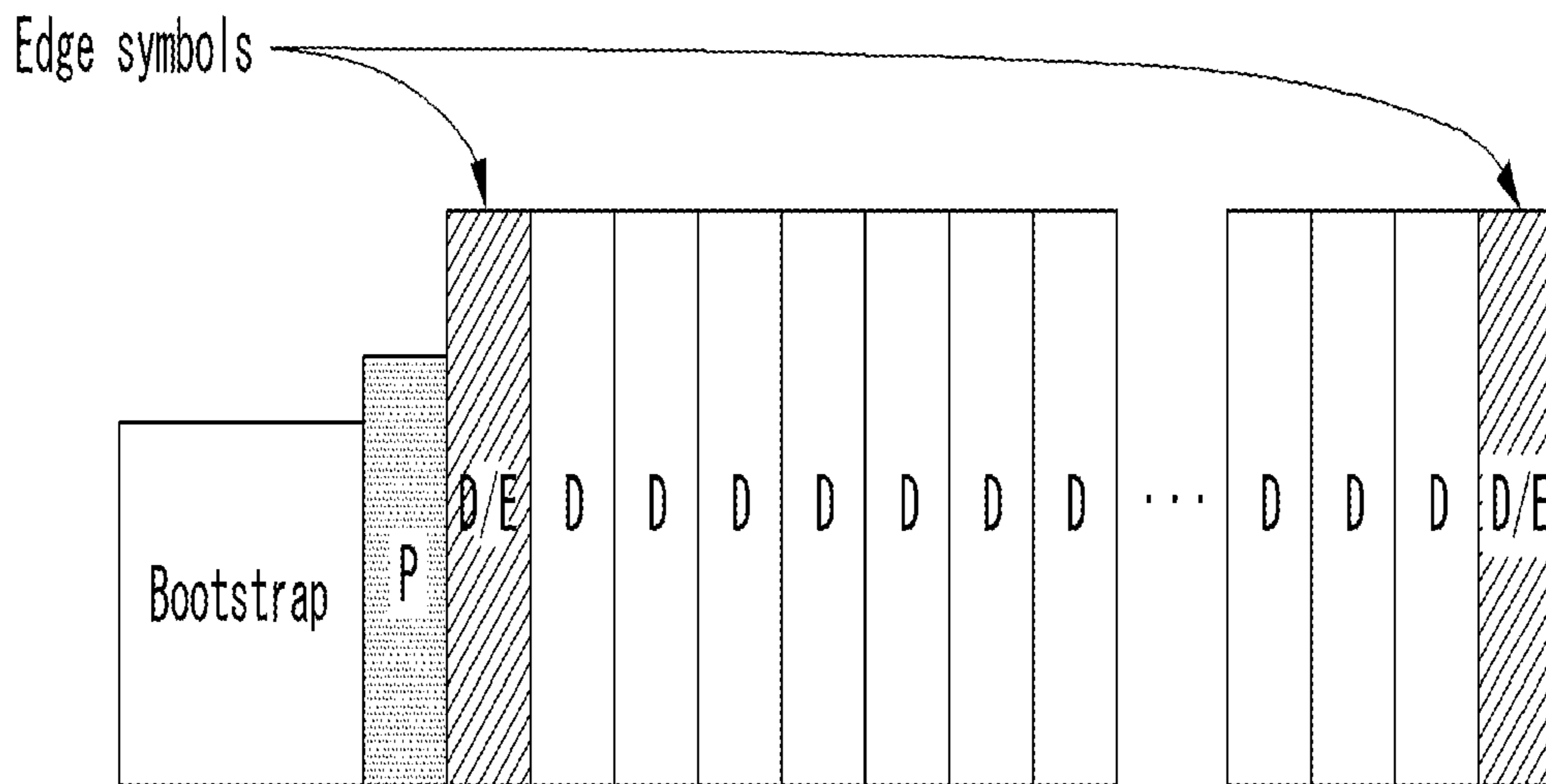

(b) Two edge symbols per frame for a single FFT frame

[Figure 41]

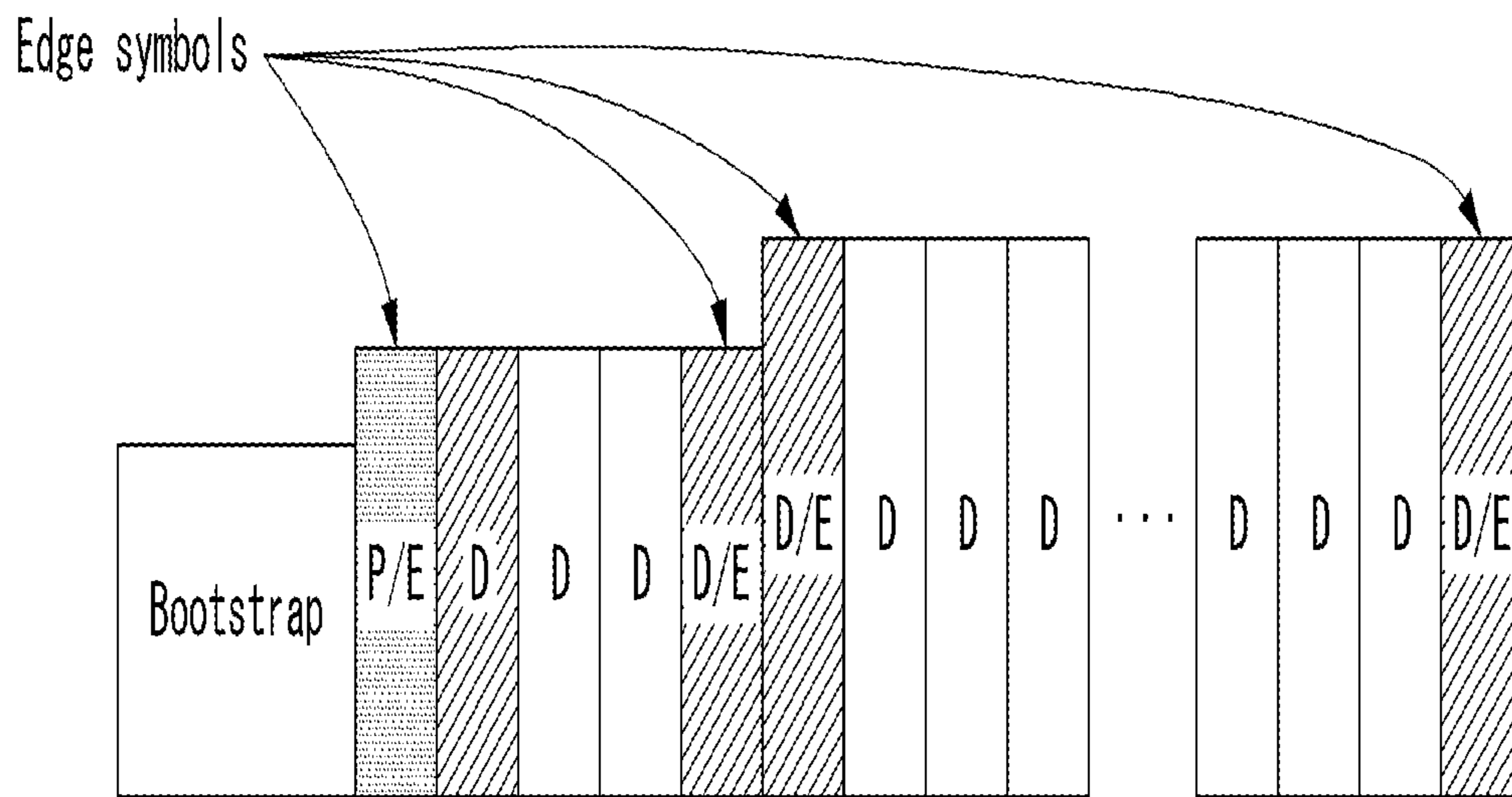

(a) Two edge symbols per sub-frame for a mixed FFT frame

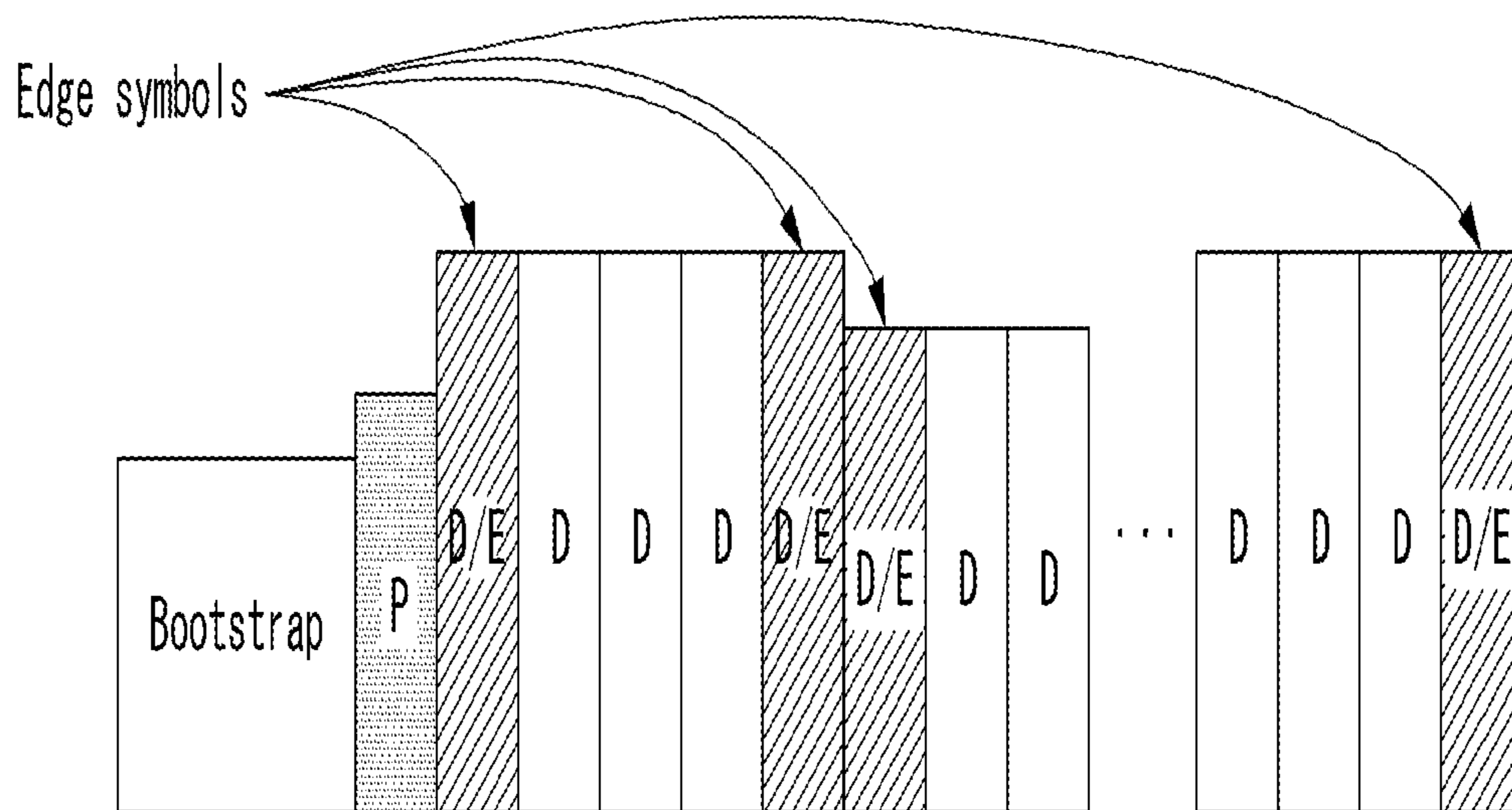

(b) Two edge symbols per sub-frame for a mixed FFT frame

[Figure 42]

GI Index	# Samples	Dx Basis	8K	16K	32K	Dx			Dy		
						8K	16K	32K	8K	16K	32K
#1	192	4	X	X	X	32	32	32	2,4	2,4	2
#2	384	4	X	X	X	16	32	32	2,4	2,4	2
#3	512	3	X	X	X	12	24	24	2,4	2,4	2
#4	768	4	X	X	X	8	16	32	2,4	2,4	2
#5	1024	3	X	X	X	6	12	24	2,4	2,4	2
#6	1536	4	X	X	X	4	8	16	2,4	2,4	2
#7	2048	3	X	X	X	3	6	12	2,4	2,4	2
#8	2432	3		X	X		6	12		2,4	2
#9	3072	4		X	X		4	8		2,4	2
#10	3648	4		X	X		4	8		2,4	2
#11	4096	3		X	X		3	6		2,4	2
#12	4864	3			X			6			2

[Figure 43]

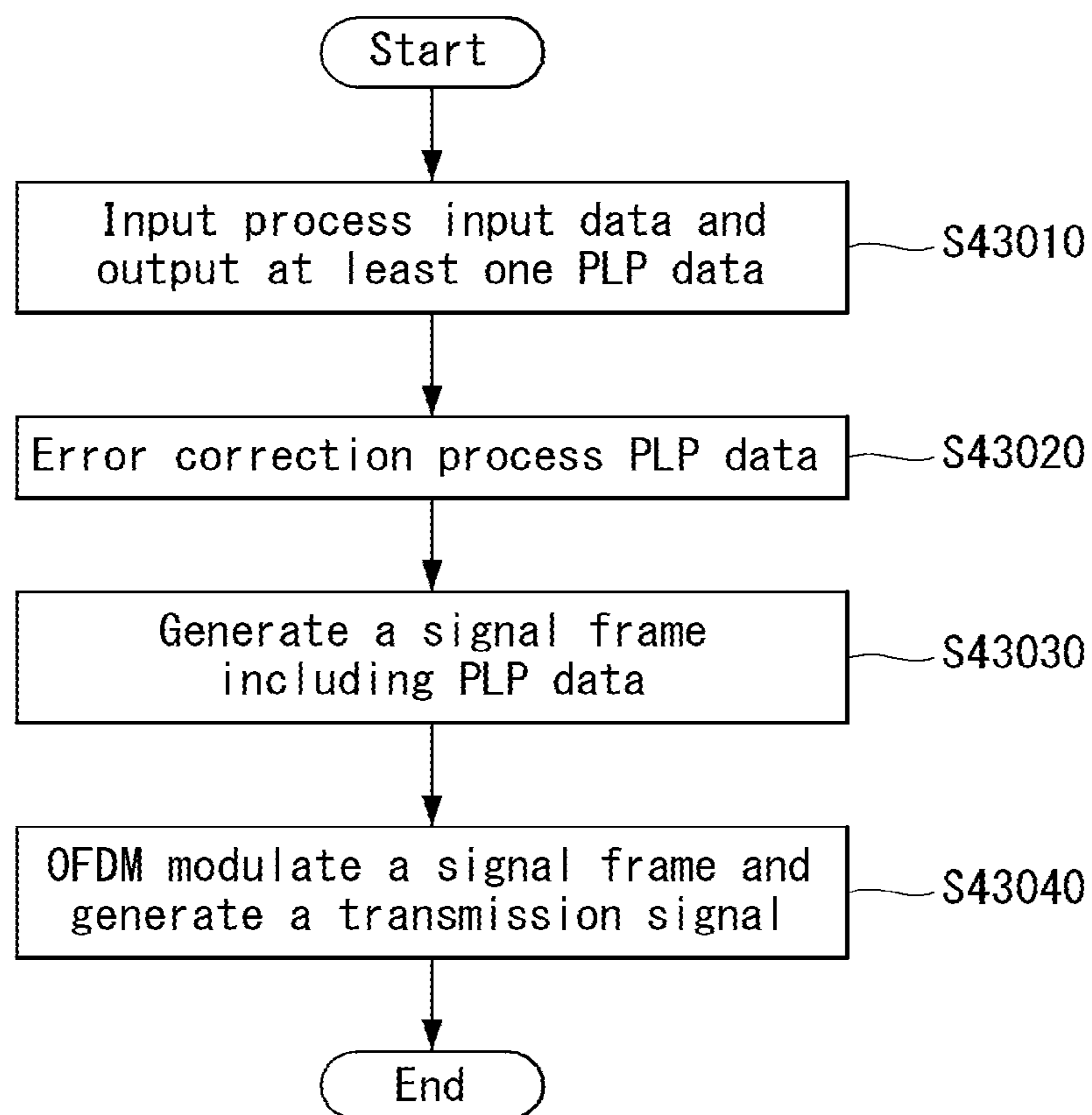

[Figure 44]

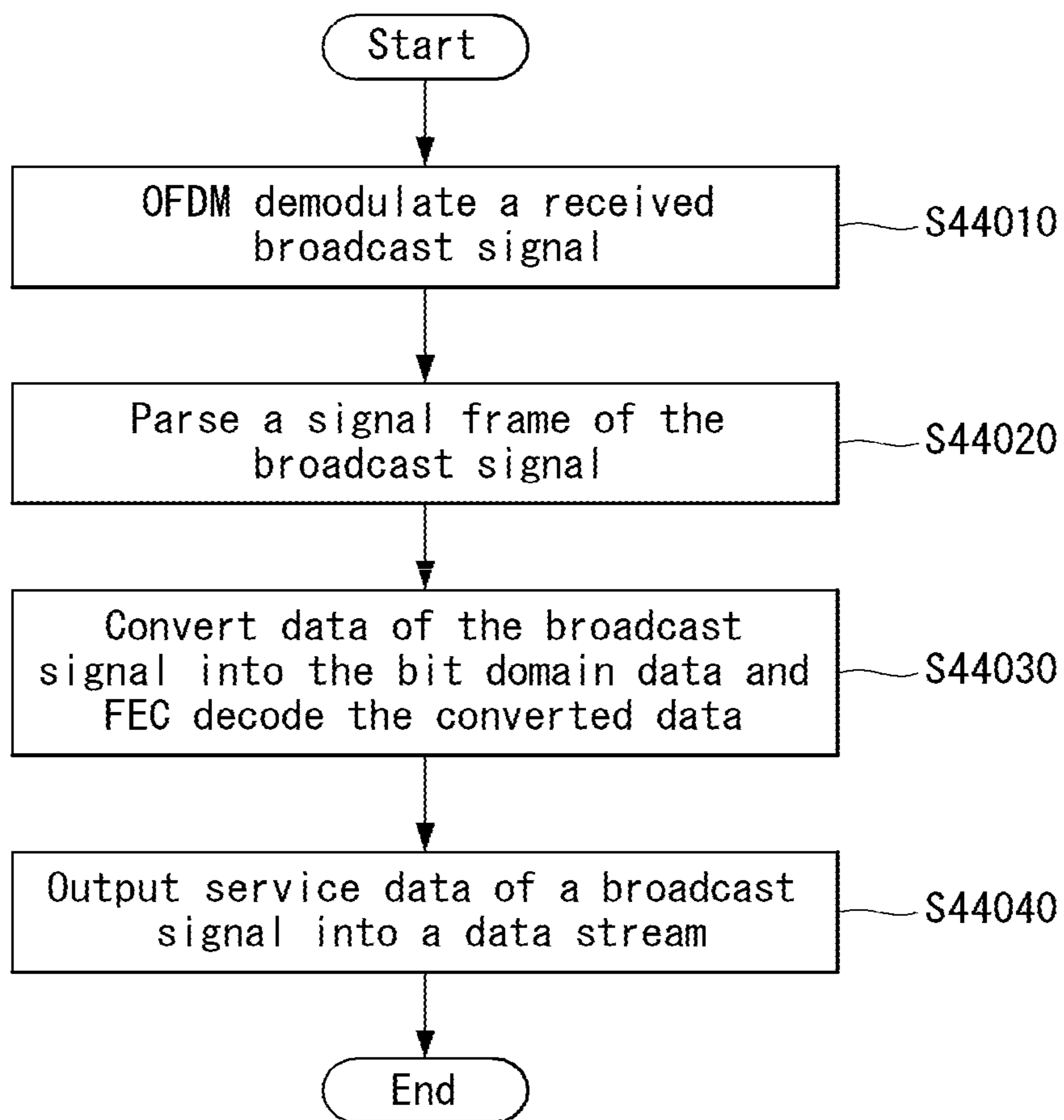

APPARATUS AND METHOD FOR SENDING AND RECEIVING BROADCAST SIGNALS

CROSS-REFERENCE TO RELATED APPLICATIONS

This application is a continuation of U.S. patent application Ser. No. 15/656,796, filed on Jul. 21, 2017, which is a continuation of U.S. patent application Ser. No. 15/014,838, filed on Feb. 3, 2016, now U.S. Pat. No. 9,742,604, issued on Aug. 22, 2017, and claims priority to Provisional Application No. 62/111,673 filed on 4 Feb. 2015 in U.S. Provisional Application No. 62/173,909 filed on 10 Jun. 2015 in US and Provisional Application No. 62/115,630 filed on 12 Feb. 2015 in US, the entire contents of which is hereby incorporated by reference in its entirety.

BACKGROUND OF THE INVENTION

Field of the Invention

The present invention relates to an apparatus for transmitting broadcast signals, an apparatus for receiving broadcast signals and methods for transmitting and receiving broadcast signals.

Discussion of the Related Art

As analog broadcast signal transmission comes to an end, various technologies for transmitting/receiving digital broadcast signals are being developed. A digital broadcast signal may include a larger amount of video/audio data than an analog broadcast signal and further include various types of additional data in addition to the video/audio data.

That is, a digital broadcast system can provide HD (high definition) images, multi-channel audio and various additional services. However, data transmission efficiency for transmission of large amounts of data, robustness of transmission/reception networks and network flexibility in consideration of mobile reception equipment need to be improved for digital broadcast.

SUMMARY OF THE INVENTION

To solve the technical problem above, a broadcast signal receiver according to an embodiment of the present invention comprises a synchronization & demodulation module configured to OFDM demodulate a received broadcast signal; a frame parsing module configured to parse a signal frame of the broadcast signal; a demapping & decoding module configured to convert PLP data of the broadcast signal to the bit domain and to FEC decode the converted PLP data; and an output processing module configured to receive the PLP data and to output a data stream, wherein the signal frame comprises a bootstrap, a preamble and at least one subframe, and wherein at least one subframe includes at least one subframe boundary symbol, the subframe boundary symbol being a first symbol or a last symbol of the at least one subframe and the subframe boundary symbol has a greater scattered pilot density than data symbols of the subframe.

In a broadcast signal receiver according to the present invention, the at least one subframe has a constant FFT size, constant GI length and a constant pilot pattern respectively, and the preamble comprises FFT size information, GI information and pilot pattern information for each subframe.

In a broadcast signal receiver according to the present invention, the scattered pilots of the subframe boundary symbol are determined based on scattered pilot density (D_x) of data symbols of the subframe, and the pilot density (D_x) indicates separation of pilot bearing carriers in frequency direction.

In a broadcast signal receiver according to the present invention, the preamble comprises subframe boundary symbol mode information and the subframe boundary symbol mode information indicates whether the first symbol of the subframe is a subframe boundary symbol or whether the last symbol of the subframe is the subframe boundary symbol.

In a broadcast signal receiver according to the present invention, at least one of a last symbol of an immediately preceding subframe or a first symbol of an immediately following subframe is the subframe boundary symbol for neighboring subframes when the signal frame comprises a plurality of subframes.

In a broadcast signal receiver according to the present invention, whether a first symbol of a first subframe immediately following the preamble is the subframe boundary symbol is determined based on whether a FFT size of the preamble and a FFT size of the first subframe are same to each other.

To solve the technical problem above, a method for receiving a broadcast signal according to an embodiment of the present invention comprises OFDM demodulating a received broadcast signal; parsing a signal frame of the broadcast signal; converting PLP data of the broadcast signal to the bit domain and FEC decoding the converted PLP data; and receiving the PLP data and outputting a data stream, wherein the signal frame comprises a bootstrap, a preamble and at least one subframe, and wherein at least one subframe includes at least one subframe boundary symbol, the subframe boundary symbol being a first symbol or a last symbol of the at least one subframe and the subframe boundary symbol has a greater scattered pilot density than data symbols of the subframe.

The present invention can process data according to service characteristics to control QoS (Quality of Services) for each service or service component, thereby providing various broadcast services.

The present invention can achieve transmission flexibility by transmitting various broadcast services through the same RF signal bandwidth.

The present invention can improve data transmission efficiency and increase robustness of transmission/reception of broadcast signals using a MIMO system.

According to the present invention, it is possible to provide broadcast signal transmission and reception methods and apparatus capable of receiving digital broadcast signals without error even with mobile reception equipment or in an indoor environment.

Further aspects and effects of the present invention will be described more detail with embodiments in belows.

BRIEF DESCRIPTION OF THE DRAWINGS

FIG. 1 illustrates a structure of an apparatus for transmitting broadcast signals for future broadcast services according to an embodiment of the present invention.

FIG. 2 illustrates an input formatting block according to one embodiment of the present invention.

FIG. 3 illustrates an input formatting block according to another embodiment of the present invention.

FIG. 4 illustrates an input formatting block according to another embodiment of the present invention.

3

FIG. 5 illustrates a BICM block according to an embodiment of the present invention.

FIG. 6 illustrates a BICM block according to another embodiment of the present invention.

FIG. 7 illustrates a frame building block according to one embodiment of the present invention.

FIG. 8 illustrates an OFDM generation block according to an embodiment of the present invention.

FIG. 9 illustrates a structure of an apparatus for receiving broadcast signals for future broadcast services according to an embodiment of the present invention.

FIG. 10 illustrates a frame structure according to an embodiment of the present invention.

FIG. 11 illustrates a signaling hierarchy structure of the frame according to an embodiment of the present invention.

FIG. 12 illustrates preamble signaling data according to an embodiment of the present invention.

FIG. 13 illustrates PLS1 data according to an embodiment of the present invention.

FIG. 14 illustrates PLS2 data according to an embodiment of the present invention.

FIG. 15 illustrates PLS2 data according to another embodiment of the present invention.

FIG. 16 illustrates a logical structure of a frame according to an embodiment of the present invention.

FIG. 17 illustrates PLS mapping according to an embodiment of the present invention.

FIG. 18 illustrates EAC mapping according to an embodiment of the present invention.

FIG. 19 illustrates FIC mapping according to an embodiment of the present invention.

FIG. 20 illustrates a type of DP according to an embodiment of the present invention.

FIG. 21 illustrates DP mapping according to an embodiment of the present invention.

FIG. 22 illustrates an FEC structure according to an embodiment of the present invention.

FIG. 23 illustrates a bit interleaving according to an embodiment of the present invention.

FIG. 24 illustrates a cell-word demultiplexing according to an embodiment of the present invention.

FIG. 25 illustrates a time interleaving according to an embodiment of the present invention.

FIG. 26 illustrates a basic operation of a twisted row-column block interleaver according to an exemplary embodiment of the present invention.

FIG. 27 illustrates an operation of a twisted row-column block interleaver according to another exemplary embodiment of the present invention.

FIG. 28 illustrates a diagonal reading pattern of the twisted row-column block interleaver according to the exemplary embodiment of the present invention.

FIG. 29 illustrates XFECBLOCK interleaved from each interleaving array according to an exemplary embodiment of the present invention.

FIG. 30 illustrates a structure of a broadcast signal transmitter according to another embodiment of the present invention.

FIG. 31 illustrates a signal frame structure according to one embodiment of the present invention.

FIG. 32 illustrates a signal frame structure according to one embodiment of the present invention.

FIG. 33 illustrates a signal frame structure according to one embodiment of the present invention.

FIG. 34 illustrates a signal frame structure according to one embodiment of the present invention.

4

FIG. 35 illustrates a signal frame structure according to one embodiment of the present invention.

FIG. 36 illustrates a signal frame structure according to another embodiment of the present invention.

FIG. 37 illustrates a signal frame structure according to a yet another embodiment of the present invention.

FIG. 38 illustrates a signal frame structure according to a still another embodiment of the present invention.

FIG. 39 illustrates a signal frame structure according to a further embodiment of the present invention.

FIG. 40 illustrates a signal frame structure and an edge symbol structure according to one embodiment of the present invention.

FIG. 41 illustrates a signal frame structure and an edge symbol structure according to another embodiment of the present invention.

FIG. 42 illustrates a scattered pilot pattern according to one embodiment of the present invention.

FIG. 43 illustrates a method for transmitting a broadcast signal according to one embodiment of the present invention.

FIG. 44 illustrates a method for receiving a broadcast signal according to one embodiment of the present invention.

DETAILED DESCRIPTION OF THE EMBODIMENTS

Reference will now be made in detail to the preferred embodiments of the present invention, examples of which are illustrated in the accompanying drawings. The detailed description, which will be given below with reference to the accompanying drawings, is intended to explain exemplary embodiments of the present invention, rather than to show the only embodiments that can be implemented according to the present invention. The following detailed description includes specific details in order to provide a thorough understanding of the present invention. However, it will be apparent to those skilled in the art that the present invention may be practiced without such specific details.

Although most terms used in the present invention have been selected from general ones widely used in the art, some terms have been arbitrarily selected by the applicant and their meanings are explained in detail in the following description as needed. Thus, the present invention should be understood based upon the intended meanings of the terms rather than their simple names or meanings. Also, the term block and module are used similarly to indicate logical/functional unit of particular signal/data processing.

The present invention provides apparatuses and methods for transmitting and receiving broadcast signals for future broadcast services. Future broadcast services according to an embodiment of the present invention include a terrestrial broadcast service, a mobile broadcast service, a UHDTV service, etc. The present invention may process broadcast signals for the future broadcast services through non-MIMO (Multiple Input Multiple Output) or MIMO according to one embodiment. A non-MIMO scheme according to an embodiment of the present invention may include a MISO (Multiple Input Single Output) scheme, a SISO (Single Input Single Output) scheme, etc.

While MISO or MIMO uses two antennas in the following for convenience of description, the present invention is applicable to systems using two or more antennas.

The present invention may define three physical layer (PL) profiles—base, handheld and advanced profiles—each optimized to minimize receiver complexity while attaining

5

the performance required for a particular use case. The physical layer (PHY) profiles are subsets of all configurations that a corresponding receiver should implement.

The three PHY profiles share most of the functional blocks but differ slightly in specific blocks and/or parameters. Additional PHY profiles can be defined in the future. For the system evolution, future profiles can also be multiplexed with the existing profiles in a single RF channel through a future extension frame (FEF). The details of each PHY profile are described below.

1. Base Profile

The base profile represents a main use case for fixed receiving devices that are usually connected to a roof-top antenna. The base profile also includes portable devices that could be transported to a place but belong to a relatively stationary reception category. Use of the base profile could be extended to handheld devices or even vehicular by some improved implementations, but those use cases are not expected for the base profile receiver operation.

Target SNR range of reception is from approximately 10 to 20 dB, which includes the 15 dB SNR reception capability of the existing broadcast system (e.g. ATSC A/53). The receiver complexity and power consumption is not as critical as in the battery-operated handheld devices, which will use the handheld profile. Key system parameters for the base profile are listed in below table 1.

TABLE 1

LDPC codeword length	16K, 64K bits
Constellation size	4~10 bpcu (bits per channel use)
Time de-interleaving memory size	$\leq 2^{19}$ data cells
Pilot patterns	Pilot pattern for fixed reception
FFT size	16K, 32K points

2. Handheld Profile

The handheld profile is designed for use in handheld and vehicular devices that operate with battery power. The devices can be moving with pedestrian or vehicle speed. The power consumption as well as the receiver complexity is very important for the implementation of the devices of the handheld profile. The target SNR range of the handheld profile is approximately 0 to 10 dB, but can be configured to reach below 0 dB when intended for deeper indoor reception.

In addition to low SNR capability, resilience to the Doppler Effect caused by receiver mobility is the most important performance attribute of the handheld profile. Key system parameters for the handheld profile are listed in the below table 2.

TABLE 2

LDPC codeword length	16K bits
Constellation size	2~8 bpcu
Time de-interleaving memory size	$\leq 2^{18}$ data cells
Pilot patterns	Pilot patterns for mobile and indoor reception
FFT size	8K, 16K points

3. Advanced Profile

The advanced profile provides highest channel capacity at the cost of more implementation complexity. This profile requires using MIMO transmission and reception, and UHDTV service is a target use case for which this profile is specifically designed. The increased capacity can also be used to allow an increased number of services in a given bandwidth, e.g., multiple SDTV or HDTV services.

6

The target SNR range of the advanced profile is approximately 20 to 30 dB. MIMO transmission may initially use existing elliptically-polarized transmission equipment, with extension to full-power cross-polarized transmission in the future. Key system parameters for the advanced profile are listed in below table 3.

TABLE 3

LDPC codeword length	16K, 64K bits
Constellation size	8~12 bpcu
Time de-interleaving memory size	$\leq 2^{19}$ data cells
Pilot patterns	Pilot pattern for fixed reception
FFT size	16K, 32K points

In this case, the base profile can be used as a profile for both the terrestrial broadcast service and the mobile broadcast service. That is, the base profile can be used to define a concept of a profile which includes the mobile profile. Also, the advanced profile can be divided advanced profile for a base profile with MIMO and advanced profile for a handheld profile with MIMO. Moreover, the three profiles can be changed according to intention of the designer.

The following terms and definitions may apply to the present invention. The following terms and definitions can be changed according to design.

auxiliary stream: sequence of cells carrying data of as yet undefined modulation and coding, which may be used for future extensions or as required by broadcasters or network operators

base data pipe: data pipe that carries service signaling data
baseband frame (or BBFRAME): set of K_{bch} bits which form the input to one FEC encoding process (BCH and LDPC encoding)

cell: modulation value that is carried by one carrier of the OFDM transmission

coded block: LDPC-encoded block of PLS1 data or one of the LDPC-encoded blocks of PLS2 data

data pipe: logical channel in the physical layer that carries service data or related metadata, which may carry one or multiple service(s) or service component(s).

data pipe unit: a basic unit for allocating data cells to a DP in a frame.

data symbol: OFDM symbol in a frame which is not a preamble symbol (the frame signaling symbol and frame edge symbol is included in the data symbol)

DP_ID: this 8-bit field identifies uniquely a DP within the system identified by the SYSTEM_ID

dummy cell: cell carrying a pseudo-random value used to fill the remaining capacity not used for PLS signaling, DPs or auxiliary streams

emergency alert channel: part of a frame that carries EAS information data

frame: physical layer time slot that starts with a preamble and ends with a frame edge symbol

frame repetition unit: a set of frames belonging to same or different physical layer profile including a FEF, which is repeated eight times in a super-frame

fast information channel: a logical channel in a frame that carries the mapping information between a service and the corresponding base DP

FECBLOCK: set of LDPC-encoded bits of a DP data

FFT size: nominal FFT size used for a particular mode, equal to the active symbol period T_s expressed in cycles of the elementary period T

frame signaling symbol: OFDM symbol with higher pilot density used at the start of a frame in certain combinations

of FFT size, guard interval and scattered pilot (sp) pattern, which carries a part of the PLS data

frame edge symbol: OFDM symbol with higher pilot density used at the end of a frame in certain combinations of FFT size, guard interval and scattered pilot pattern

frame-group: the set of all the frames having the same PHY profile type in a super-frame.

future extension frame: physical layer time slot within the super-frame that could be used for future extension, which starts with a preamble

Futurecast UTB system: proposed physical layer broadcasting system, of which the input is one or more MPEG2-TS or IP or general stream(s) and of which the output is an RF signal

input stream: A stream of data for an ensemble of services delivered to the end users by the system.

normal data symbol: data symbol excluding the frame signaling symbol and the frame edge symbol

PHY profile: subset of all configurations that a corresponding receiver should implement

PLS: physical layer signaling data consisting of PLS1 and PLS2

PLS1: a first set of PLS data carried in the FSS symbols having a fixed size, coding and modulation, which carries basic information about the system as well as the parameters needed to decode the PLS2

NOTE: PLS1 data remains constant for the duration of a frame-group.

PLS2: a second set of PLS data transmitted in the FSS symbol, which carries more detailed PLS data about the system and the DPs

PLS2 dynamic data: PLS2 data that may dynamically change frame-by-frame

PLS2 static data: PLS2 data that remains static for the duration of a frame-group

preamble signaling data: signaling data carried by the preamble symbol and used to identify the basic mode of the system

preamble symbol: fixed-length pilot symbol that carries basic PLS data and is located in the beginning of a frame

NOTE: The preamble symbol is mainly used for fast initial band scan to detect the system signal, its timing, frequency offset, and FFT-size.

reserved for future use: not defined by the present document but may be defined in future

super-frame: set of eight frame repetition units

time interleaving block (TI block): set of cells within which time interleaving is carried out, corresponding to one use of the time interleaver memory

TI group: unit over which dynamic capacity allocation for a particular DP is carried out, made up of an integer, dynamically varying number of XFECBLOCKs

NOTE: The TI group may be mapped directly to one frame or may be mapped to multiple frames. It may contain one or more TI blocks.

Type 1 DP: DP of a frame where all DPs are mapped into the frame in TDM fashion

Type 2 DP: DP of a frame where all DPs are mapped into the frame in FDM fashion

XFECBLOCK: set of Ncells cells carrying all the bits of one LDPC FECBLOCK

FIG. 1 illustrates a structure of an apparatus for transmitting broadcast signals for future broadcast services according to an embodiment of the present invention.

The apparatus for transmitting broadcast signals for future broadcast services according to an embodiment of the present invention can include an input formatting block 1000, a

BICM (Bit interleaved coding & modulation) block 1010, a frame structure block 1020, an OFDM (Orthogonal Frequency Division Multiplexing) generation block 1030 and a signaling generation block 1040. A description will be given of the operation of each module of the apparatus for transmitting broadcast signals.

IP stream/packets and MPEG2-TS are the main input formats, other stream types are handled as General Streams. In addition to these data inputs, Management Information is input to control the scheduling and allocation of the corresponding bandwidth for each input stream. One or multiple TS stream(s), IP stream(s) and/or General Stream(s) inputs are simultaneously allowed.

The input formatting block 1000 can demultiplex each input stream into one or multiple data pipe(s), to each of which an independent coding and modulation is applied. The data pipe (DP) is the basic unit for robustness control, thereby affecting quality-of-service (QoS). One or multiple service(s) or service component(s) can be carried by a single DP. Details of operations of the input formatting block 1000 will be described later.

The data pipe is a logical channel in the physical layer that carries service data or related metadata, which may carry one or multiple service(s) or service component(s).

Also, the data pipe unit: a basic unit for allocating data cells to a DP in a frame.

In the BICM block 1010, parity data is added for error correction and the encoded bit streams are mapped to complex-value constellation symbols. The symbols are interleaved across a specific interleaving depth that is used for the corresponding DP. For the advanced profile, MIMO encoding is performed in the BICM block 1010 and the additional data path is added at the output for MIMO transmission. Details of operations of the BICM block 1010 will be described later.

The Frame Building block 1020 can map the data cells of the input DPs into the OFDM symbols within a frame. After mapping, the frequency interleaving is used for frequency-domain diversity, especially to combat frequency-selective fading channels. Details of operations of the Frame Building block 1020 will be described later.

After inserting a preamble at the beginning of each frame, the OFDM Generation block 1030 can apply conventional OFDM modulation having a cyclic prefix as guard interval. For antenna space diversity, a distributed MISO scheme is applied across the transmitters. In addition, a Peak-to-Average Power Reduction (PAPR) scheme is performed in the time domain. For flexible network planning, this proposal provides a set of various FFT sizes, guard interval lengths and corresponding pilot patterns. Details of operations of the OFDM Generation block 1030 will be described later.

The Signaling Generation block 1040 can create physical layer signaling information used for the operation of each functional block. This signaling information is also transmitted so that the services of interest are properly recovered at the receiver side. Details of operations of the Signaling Generation block 1040 will be described later.

FIGS. 2, 3 and 4 illustrate the input formatting block 1000 according to embodiments of the present invention. A description will be given of each figure.

FIG. 2 illustrates an input formatting block according to one embodiment of the present invention. FIG. 2 shows an input formatting module when the input signal is a single input stream.

The input formatting block illustrated in FIG. 2 corresponds to an embodiment of the input formatting block **1000** described with reference to FIG. 1.

The input to the physical layer may be composed of one or multiple data streams. Each data stream is carried by one DP. The mode adaptation modules slice the incoming data stream into data fields of the baseband frame (BBF). The system supports three types of input data streams: MPEG2-TS, Internet protocol (IP) and Generic stream (GS). MPEG2-TS is characterized by fixed length (188 byte) packets with the first byte being a sync-byte (0x47). An IP stream is composed of variable length IP datagram packets, as signaled within IP packet headers. The system supports both IPv4 and IPv6 for the IP stream. GS may be composed of variable length packets or constant length packets, signaled within encapsulation packet headers.

(a) shows a mode adaptation block **2000** and a stream adaptation **2010** for signal DP and (b) shows a PLS generation block **2020** and a PLS scrambler **2030** for generating and processing PLS data. A description will be given of the operation of each block.

The Input Stream Splitter splits the input TS, IP, GS streams into multiple service or service component (audio, video, etc.) streams. The mode adaptation module **2010** is comprised of a CRC Encoder, BB (baseband) Frame Slicer, and BB Frame Header Insertion block.

The CRC Encoder provides three kinds of CRC encoding for error detection at the user packet (UP) level, i.e., CRC-8, CRC-16, and CRC-32. The computed CRC bytes are appended after the UP. CRC-8 is used for TS stream and CRC-32 for IP stream. If the GS stream doesn't provide the CRC encoding, the proposed CRC encoding should be applied.

BB Frame Slicer maps the input into an internal logical-bit format. The first received bit is defined to be the MSB. The BB Frame Slicer allocates a number of input bits equal to the available data field capacity. To allocate a number of input bits equal to the BBF payload, the UP packet stream is sliced to fit the data field of BBF.

BB Frame Header Insertion block can insert fixed length BBF header of 2 bytes is inserted in front of the BB Frame. The BBF header is composed of STUFFI (1 bit), SYNCD (13 bits), and RFU (2 bits). In addition to the fixed 2-Byte BBF header, BBF can have an extension field (1 or 3 bytes) at the end of the 2-byte BBF header.

The stream adaptation **2010** is comprised of stuffing insertion block and BB scrambler.

The stuffing insertion block can insert stuffing field into a payload of a BB frame. If the input data to the stream adaptation is sufficient to fill a BB-Frame, STUFFI is set to '0' and the BBF has no stuffing field. Otherwise STUFFI is set to '1' and the stuffing field is inserted immediately after the BBF header. The stuffing field comprises two bytes of the stuffing field header and a variable size of stuffing data.

The BB scrambler scrambles complete BBF for energy dispersal. The scrambling sequence is synchronous with the BBF. The scrambling sequence is generated by the feedback shift register.

The PLS generation block **2020** can generate physical layer signaling (PLS) data. The PLS provides the receiver with a means to access physical layer DPs. The PLS data consists of PLS1 data and PLS2 data.

The PLS1 data is a first set of PLS data carried in the FSS symbols in the frame having a fixed size, coding and modulation, which carries basic information about the system as well as the parameters needed to decode the PLS2 data. The PLS1 data provides basic transmission parameters

including parameters required to enable the reception and decoding of the PLS2 data. Also, the PLS1 data remains constant for the duration of a frame-group.

The PLS2 data is a second set of PLS data transmitted in the FSS symbol, which carries more detailed PLS data about the system and the DPs. The PLS2 contains parameters that provide sufficient information for the receiver to decode the desired DP. The PLS2 signaling further consists of two types of parameters, PLS2 Static data (PLS2-STAT data) and PLS2 dynamic data (PLS2-DYN data). The PLS2 Static data is PLS2 data that remains static for the duration of a frame-group and the PLS2 dynamic data is PLS2 data that may dynamically change frame-by-frame.

Details of the PLS data will be described later.

The PLS scrambler **2030** can scramble the generated PLS data for energy dispersal.

The above-described blocks may be omitted or replaced by blocks having similar or identical functions.

FIG. 3 illustrates an input formatting block according to another embodiment of the present invention.

The input formatting block illustrated in FIG. 3 corresponds to an embodiment of the input formatting block **1000** described with reference to FIG. 1.

FIG. 3 shows a mode adaptation block of the input formatting block when the input signal corresponds to multiple input streams.

The mode adaptation block of the input formatting block for processing the multiple input streams can independently process the multiple input streams.

Referring to FIG. 3, the mode adaptation block for respectively processing the multiple input streams can include an input stream splitter **3000**, an input stream synchronizer **3010**, a compensating delay block **3020**, a null packet deletion block **3030**, a head compression block **3040**, a CRC encoder **3050**, a BB frame slicer **3060** and a BB header insertion block **3070**. Description will be given of each block of the mode adaptation block.

Operations of the CRC encoder **3050**, BB frame slicer **3060** and BB header insertion block **3070** correspond to those of the CRC encoder, BB frame slicer and BB header insertion block described with reference to FIG. 2 and thus description thereof is omitted.

The input stream splitter **3000** can split the input TS, IP, GS streams into multiple service or service component (audio, video, etc.) streams.

The input stream synchronizer **3010** may be referred as ISSY. The ISSY can provide suitable means to guarantee Constant Bit Rate (CBR) and constant end-to-end transmission delay for any input data format. The ISSY is always used for the case of multiple DPs carrying TS, and optionally used for multiple DPs carrying GS streams.

The compensating delay block **3020** can delay the split TS packet stream following the insertion of ISSY information to allow a TS packet recombining mechanism without requiring additional memory in the receiver.

The null packet deletion block **3030**, is used only for the TS input stream case. Some TS input streams or split TS streams may have a large number of null-packets present in order to accommodate VBR (variable bit-rate) services in a CBR TS stream. In this case, in order to avoid unnecessary transmission overhead, null-packets can be identified and not transmitted. In the receiver, removed null-packets can be re-inserted in the exact place where they were originally by reference to a deleted null-packet (DNP) counter that is inserted in the transmission, thus guaranteeing constant bit-rate and avoiding the need for time-stamp (PCR) updating.

The head compression block **3040** can provide packet header compression to increase transmission efficiency for TS or IP input streams. Because the receiver can have a priori information on certain parts of the header, this known information can be deleted in the transmitter.

For Transport Stream, the receiver has a-priori information about the sync-byte configuration (0x47) and the packet length (188 Byte). If the input TS stream carries content that has only one PID, i.e., for only one service component (video, audio, etc.) or service sub-component (SVC base layer, SVC enhancement layer, MVC base view or MVC dependent views), TS packet header compression can be applied (optionally) to the Transport Stream. IP packet header compression is used optionally if the input stream is an IP stream.

The above-described blocks may be omitted or replaced by blocks having similar or identical functions.

FIG. 4 illustrates an input formatting block according to another embodiment of the present invention.

The input formatting block illustrated in FIG. 4 corresponds to an embodiment of the input formatting block **1000** described with reference to FIG. 1.

FIG. 4 illustrates a stream adaptation block of the input formatting module when the input signal corresponds to multiple input streams.

Referring to FIG. 4, the mode adaptation block for respectively processing the multiple input streams can include a scheduler **4000**, an 1-Frame delay block **4010**, a stuffing insertion block **4020**, an in-band signaling **4030**, a BB Frame scrambler **4040**, a PLS generation block **4050** and a PLS scrambler **4060**. Description will be given of each block of the stream adaptation block.

Operations of the stuffing insertion block **4020**, the BB Frame scrambler **4040**, the PLS generation block **4050** and the PLS scrambler **4060** correspond to those of the stuffing insertion block, BB scrambler, PLS generation block and the PLS scrambler described with reference to FIG. 2 and thus description thereof is omitted.

The scheduler **4000** can determine the overall cell allocation across the entire frame from the amount of FEC-BLOCKS of each DP. Including the allocation for PLS, EAC and FIC, the scheduler generate the values of PLS2-DYN data, which is transmitted as in-band signaling or PLS cell in FSS of the frame. Details of FECBLOCK, EAC and FIC will be described later.

The 1-Frame delay block **4010** can delay the input data by one transmission frame such that scheduling information about the next frame can be transmitted through the current frame for in-band signaling information to be inserted into the DPs.

The in-band signaling **4030** can insert un-delayed part of the PLS2 data into a DP of a frame.

The above-described blocks may be omitted or replaced by blocks having similar or identical functions.

FIG. 5 illustrates a BICM block according to an embodiment of the present invention.

The BICM block illustrated in FIG. 5 corresponds to an embodiment of the BICM block **1010** described with reference to FIG. 1.

As described above, the apparatus for transmitting broadcast signals for future broadcast services according to an embodiment of the present invention can provide a terrestrial broadcast service, mobile broadcast service, UHDTV service, etc.

Since QoS (quality of service) depends on characteristics of a service provided by the apparatus for transmitting broadcast signals for future broadcast services according to

an embodiment of the present invention, data corresponding to respective services needs to be processed through different schemes. Accordingly, the a BICM block according to an embodiment of the present invention can independently process DPs input thereto by independently applying SISO, MISO and MIMO schemes to the data pipes respectively corresponding to data paths. Consequently, the apparatus for transmitting broadcast signals for future broadcast services according to an embodiment of the present invention can control QoS for each service or service component transmitted through each DP.

(a) shows the BICM block shared by the base profile and the handheld profile and (b) shows the BICM block of the advanced profile.

The BICM block shared by the base profile and the handheld profile and the BICM block of the advanced profile can include plural processing blocks for processing each DP.

A description will be given of each processing block of the BICM block for the base profile and the handheld profile and the BICM block for the advanced profile.

A processing block **5000** of the BICM block for the base profile and the handheld profile can include a Data FEC encoder **5010**, a bit interleaver **5020**, a constellation mapper **5030**, an SSD (Signal Space Diversity) encoding block **5040** and a time interleaver **5050**.

The Data FEC encoder **5010** can perform the FEC encoding on the input BBF to generate FECBLOCK procedure using outer coding (BCH), and inner coding (LDPC). The outer coding (BCH) is optional coding method. Details of operations of the Data FEC encoder **5010** will be described later.

The bit interleaver **5020** can interleave outputs of the Data FEC encoder **5010** to achieve optimized performance with combination of the LDPC codes and modulation scheme while providing an efficiently implementable structure. Details of operations of the bit interleaver **5020** will be described later.

The constellation mapper **5030** can modulate each cell word from the bit interleaver **5020** in the base and the handheld profiles, or cell word from the Cell-word demultiplexer **5010-1** in the advanced profile using either QPSK, QAM-16, non-uniform QAM (NUQ-64, NUQ-256, NUQ-1024) or non-uniform constellation (NUC-16, NUC-64, NUC-256, NUC-1024) to give a power-normalized constellation point, el. This constellation mapping is applied only for DPs. Observe that QAM-16 and NUQs are square shaped, while NUCs have arbitrary shape. When each constellation is rotated by any multiple of 90 degrees, the rotated constellation exactly overlaps with its original one. This "rotation-sense" symmetric property makes the capacities and the average powers of the real and imaginary components equal to each other. Both NUQs and NUCs are defined specifically for each code rate and the particular one used is signaled by the parameter DP_MOD filed in PLS2 data.

The SSD encoding block **5040** can precode cells in two (2D), three (3D), and four (4D) dimensions to increase the reception robustness under difficult fading conditions.

The time interleaver **5050** can operate at the DP level. The parameters of time interleaving (TI) may be set differently for each DP. Details of operations of the time interleaver **5050** will be described later.

A processing block **5000-1** of the BICM block for the advanced profile can include the Data FEC encoder, bit interleaver, constellation mapper, and time interleaver. However, the processing block **5000-1** is distinguished from the

processing block **5000** further includes a cell-word demultiplexer **5010-1** and a MIMO encoding block **5020-1**.

Also, the operations of the Data FEC encoder, bit interleaver, constellation mapper, and time interleaver in the processing block **5000-1** correspond to those of the Data FEC encoder **5010**, bit interleaver **5020**, constellation mapper **5030**, and time interleaver **5050** described and thus description thereof is omitted.

The cell-word demultiplexer **5010-1** is used for the DP of the advanced profile to divide the single cell-word stream into dual cell-word streams for MIMO processing. Details of operations of the cell-word demultiplexer **5010-1** will be described later.

The MIMO encoding block **5020-1** can process the output of the cell-word demultiplexer **5010-1** using MIMO encoding scheme. The MIMO encoding scheme was optimized for broadcasting signal transmission. The MIMO technology is a promising way to get a capacity increase but it depends on channel characteristics. Especially for broadcasting, the strong LOS component of the channel or a difference in the received signal power between two antennas caused by different signal propagation characteristics makes it difficult to get capacity gain from MIMO. The proposed MIMO encoding scheme overcomes this problem using a rotation-based pre-coding and phase randomization of one of the MIMO output signals.

MIMO encoding is intended for a 2x2 MIMO system requiring at least two antennas at both the transmitter and the receiver. Two MIMO encoding modes are defined in this proposal; full-rate spatial multiplexing (FR-SM) and full-rate full-diversity spatial multiplexing (FRFD-SM). The FR-SM encoding provides capacity increase with relatively small complexity increase at the receiver side while the FRFD-SM encoding provides capacity increase and additional diversity gain with a great complexity increase at the receiver side. The proposed MIMO encoding scheme has no restriction on the antenna polarity configuration.

MIMO processing is required for the advanced profile frame, which means all DPs in the advanced profile frame are processed by the MIMO encoder. MIMO processing is applied at DP level. Pairs of the Constellation Mapper outputs NUQ (e1,i and e2,i) are fed to the input of the MIMO Encoder. Paired MIMO Encoder output (g1,i and g2,i) is transmitted by the same carrier k and OFDM symbol l of their respective TX antennas.

The above-described blocks may be omitted or replaced by blocks having similar or identical functions.

FIG. 6 illustrates a BICM block according to another embodiment of the present invention.

The BICM block illustrated in FIG. 6 corresponds to an embodiment of the BICM block **1010** described with reference to FIG. 1.

FIG. 6 illustrates a BICM block for protection of physical layer signaling (PLS), emergency alert channel (EAC) and fast information channel (FIC). EAC is a part of a frame that carries EAS information data and FIC is a logical channel in a frame that carries the mapping information between a service and the corresponding base DP. Details of the EAC and FIC will be described later.

Referring to FIG. 6, the BICM block for protection of PLS, EAC and FIC can include a PLS FEC encoder **6000**, a bit interleaver **6010**, a constellation mapper **6020** and time interleaver **6030**.

Also, the PLS FEC encoder **6000** can include a scrambler, BCH encoding/zero insertion block, LDPC encoding block and LDPC parity puncturing block. Description will be given of each block of the BICM block.

The PLS FEC encoder **6000** can encode the scrambled PLS 1/2 data, EAC and FIC section.

The scrambler can scramble PLS1 data and PLS2 data before BCH encoding and shortened and punctured LDPC encoding.

The BCH encoding/zero insertion block can perform outer encoding on the scrambled PLS 1/2 data using the shortened BCH code for PLS protection and insert zero bits after the BCH encoding. For PLS1 data only, the output bits of the zero insertion may be permuted before LDPC encoding.

The LDPC encoding block can encode the output of the BCH encoding/zero insertion block using LDPC code. To generate a complete coded block, Cldpc, parity bits, Pldpc are encoded systematically from each zero-inserted PLS information block, Ildpc and appended after it.

$$C_{ldpc} = [I_{ldpc} P_{ldpc}] = [i_0, i_1, \dots, i_{K_{ldpc}-1}, p_0, p_1, \dots, p_{N_{ldpc}-K_{ldpc}-1}] \quad \text{[Equation 1]}$$

The LDPC code parameters for PLS1 and PLS2 are as following table 4.

TABLE 4

Signal- Type	Ksig	Kbch	Nbch_ parity	Kldpc (=Nbch)	Nldpc_ parity	code rate	Qldpc	
PLS1	342	1020	60	1080	4320	3240	1/4	36
PLS2	<1021							
	>1020	2100		2160	7200	5040	3/10	56

The LDPC parity puncturing block can perform puncturing on the PLS1 data and PLS 2 data.

When shortening is applied to the PLS1 data protection, some LDPC parity bits are punctured after LDPC encoding. Also, for the PLS2 data protection, the LDPC parity bits of PLS2 are punctured after LDPC encoding. These punctured bits are not transmitted.

The bit interleaver **6010** can interleave the each shortened and punctured PLS1 data and PLS2 data.

The constellation mapper **6020** can map the bit interleaved PLS1 data and PLS2 data onto constellations.

The time interleaver **6030** can interleave the mapped PLS1 data and PLS2 data.

The above-described blocks may be omitted or replaced by blocks having similar or identical functions.

FIG. 7 illustrates a frame building block according to one embodiment of the present invention.

The frame building block illustrated in FIG. 7 corresponds to an embodiment of the frame building block **1020** described with reference to FIG. 1.

Referring to FIG. 7, the frame building block can include a delay compensation block **7000**, a cell mapper **7010** and a frequency interleaver **7020**. Description will be given of each block of the frame building block.

The delay compensation block **7000** can adjust the timing between the data pipes and the corresponding PLS data to ensure that they are co-timed at the transmitter end. The PLS data is delayed by the same amount as data pipes are by addressing the delays of data pipes caused by the Input Formatting block and BICM block. The delay of the BICM block is mainly due to the time interleaver **5050**. In-band signaling data carries information of the next TI group so that they are carried one frame ahead of the DPs to be signaled. The Delay Compensating block delays in-band signaling data accordingly.

The cell mapper **7010** can map PLS, EAC, FIC, DPs, auxiliary streams and dummy cells into the active carriers of the OFDM symbols in the frame. The basic function of the cell mapper **7010** is to map data cells produced by the TIs for each of the DPs, PLS cells, and EAC/FIC cells, if any, into arrays of active OFDM cells corresponding to each of the OFDM symbols within a frame. Service signaling data (such as PSI (program specific information)/SI) can be separately gathered and sent by a data pipe. The Cell Mapper operates according to the dynamic information produced by the scheduler and the configuration of the frame structure. Details of the frame will be described later.

The frequency interleaver **7020** can randomly interleave data cells received from the cell mapper **7010** to provide frequency diversity. Also, the frequency interleaver **7020** can operate on very OFDM symbol pair comprised of two sequential OFDM symbols using a different interleaving-seed order to get maximum interleaving gain in a single frame. Details of operations of the frequency interleaver **7020** will be described later.

The above-described blocks may be omitted or replaced by blocks having similar or identical functions.

FIG. **8** illustrates an OFMD generation block according to an embodiment of the present invention.

The OFMD generation block illustrated in FIG. **8** corresponds to an embodiment of the OFMD generation block **1030** described with reference to FIG. **1**.

The OFDM generation block modulates the OFDM carriers by the cells produced by the Frame Building block, inserts the pilots, and produces the time domain signal for transmission. Also, this block subsequently inserts guard intervals, and applies PAPR (Peak-to-Average Power Ratio) reduction processing to produce the final RF signal.

Referring to FIG. **8**, the frame building block can include a pilot and reserved tone insertion block **8000**, a 2D-eSFN encoding block **8010**, an IFFT (Inverse Fast Fourier Transform) block **8020**, a PAPR reduction block **8030**, a guard interval insertion block **8040**, a preamble insertion block **8050**, other system insertion block **8060** and a DAC block **8070**. Description will be given of each block of the frame building block.

The pilot and reserved tone insertion block **8000** can insert pilots and the reserved tone.

Various cells within the OFDM symbol are modulated with reference information, known as pilots, which have transmitted values known a priori in the receiver. The information of pilot cells is made up of scattered pilots (SP), continual pilots (CP), edge pilots (EP), FSS (frame signaling symbol) pilots and FES (frame edge symbol) pilots. Each pilot is transmitted at a particular boosted power level according to pilot type and pilot pattern. The value of the pilot information is derived from a reference sequence, which is a series of values, one for each transmitted carrier on any given symbol. The pilots can be used for frame synchronization, frequency synchronization, time synchronization, channel estimation, and transmission mode identification, and also can be used to follow the phase noise.

Reference information, taken from the reference sequence, is transmitted in scattered pilot cells in every symbol except the preamble, FSS and FES of the frame. Continual pilots are inserted in every symbol of the frame. The number and location of continual pilots depends on both the FFT size and the scattered pilot pattern. The edge carriers are edge pilots in every symbol except for the preamble symbol. They are inserted in order to allow frequency interpolation up to the edge of the spectrum. FSS pilots are

inserted in FSS(s) and FES pilots are inserted in FES. They are inserted in order to allow time interpolation up to the edge of the frame.

The system according to an embodiment of the present invention supports the SFN network, where distributed MISO scheme is optionally used to support very robust transmission mode. The 2D-eSFN is a distributed MISO scheme that uses multiple TX antennas, each of which is located in the different transmitter site in the SFN network.

The 2D-eSFN encoding block **8010** can process a 2D-eSFN processing to distorts the phase of the signals transmitted from multiple transmitters, in order to create both time and frequency diversity in the SFN configuration. Hence, burst errors due to low flat fading or deep-fading for a long time can be mitigated.

The IFFT block **8020** can modulate the output from the 2D-eSFN encoding block **8010** using OFDM modulation scheme. Any cell in the data symbols which has not been designated as a pilot (or as a reserved tone) carries one of the data cells from the frequency interleaver. The cells are mapped to OFDM carriers.

The PAPR reduction block **8030** can perform a PAPR reduction on input signal using various PAPR reduction algorithm in the time domain.

The guard interval insertion block **8040** can insert guard intervals and the preamble insertion block **8050** can insert preamble in front of the signal. Details of a structure of the preamble will be described later. The other system insertion block **8060** can multiplex signals of a plurality of broadcast transmission/reception systems in the time domain such that data of two or more different broadcast transmission/reception systems providing broadcast services can be simultaneously transmitted in the same RF signal bandwidth. In this case, the two or more different broadcast transmission/reception systems refer to systems providing different broadcast services. The different broadcast services may refer to a terrestrial broadcast service, mobile broadcast service, etc. Data related to respective broadcast services can be transmitted through different frames.

The DAC block **8070** can convert an input digital signal into an analog signal and output the analog signal. The signal output from the DAC block **8070** can be transmitted through multiple output antennas according to the physical layer profiles. A Tx antenna according to an embodiment of the present invention can have vertical or horizontal polarity.

The above-described blocks may be omitted or replaced by blocks having similar or identical functions according to design.

FIG. **9** illustrates a structure of an apparatus for receiving broadcast signals for future broadcast services according to an embodiment of the present invention.

The apparatus for receiving broadcast signals for future broadcast services according to an embodiment of the present invention can correspond to the apparatus for transmitting broadcast signals for future broadcast services, described with reference to FIG. **1**.

The apparatus for receiving broadcast signals for future broadcast services according to an embodiment of the present invention can include a synchronization & demodulation module **9000**, a frame parsing module **9010**, a demapping & decoding module **9020**, an output processor **9030** and a signaling decoding module **9040**. A description will be given of operation of each module of the apparatus for receiving broadcast signals.

The synchronization & demodulation module **9000** can receive input signals through m Rx antennas, perform signal detection and synchronization with respect to a system

corresponding to the apparatus for receiving broadcast signals and carry out demodulation corresponding to a reverse procedure of the procedure performed by the apparatus for transmitting broadcast signals.

The frame parsing module **9010** can parse input signal frames and extract data through which a service selected by a user is transmitted. If the apparatus for transmitting broadcast signals performs interleaving, the frame parsing module **9010** can carry out deinterleaving corresponding to a reverse procedure of interleaving. In this case, the positions of a signal and data that need to be extracted can be obtained by decoding data output from the signaling decoding module **9400** to restore scheduling information generated by the apparatus for transmitting broadcast signals.

The demapping & decoding module **9020** can convert the input signals into bit domain data and then deinterleave the same as necessary. The demapping & decoding module **9200** can perform demapping for mapping applied for transmission efficiency and correct an error generated on a transmission channel through decoding. In this case, the demapping & decoding module **9020** can obtain transmission parameters necessary for demapping and decoding by decoding the data output from the signaling decoding module **9040**.

The output processor **9030** can perform reverse procedures of various compression/signal processing procedures which are applied by the apparatus for transmitting broadcast signals to improve transmission efficiency. In this case, the output processor **9030** can acquire necessary control information from data output from the signaling decoding module **9040**. The output of the output processor **9030** corresponds to a signal input to the apparatus for transmitting broadcast signals and may be MPEG-TSs, IP streams (v4 or v6) and generic streams.

The signaling decoding module **9040** can obtain PLS information from the signal demodulated by the synchronization & demodulation module **9000**. As described above, the frame parsing module **9010**, demapping & decoding module **9020** and output processor **9030** can execute functions thereof using the data output from the signaling decoding module **9040**.

FIG. 10 illustrates a frame structure according to an embodiment of the present invention.

FIG. 10 shows an example configuration of the frame types and FRUs in a super-frame. (a) shows a super frame according to an embodiment of the present invention, (b) shows FRU (Frame Repetition Unit) according to an embodiment of the present invention, (c) shows frames of variable PHY profiles in the FRU and (d) shows a structure of a frame.

A super-frame may be composed of eight FRUs. The FRU is a basic multiplexing unit for TDM of the frames, and is repeated eight times in a super-frame.

Each frame in the FRU belongs to one of the PHY profiles, (base, handheld, advanced) or FEF. The maximum allowed number of the frames in the FRU is four and a given PHY profile can appear any number of times from zero times to four times in the FRU (e.g., base, base, handheld, advanced). PHY profile definitions can be extended using reserved values of the PHY_PROFILE in the preamble, if required.

The FEF part is inserted at the end of the FRU, if included. When the FEF is included in the FRU, the minimum number of FEFs is 8 in a super-frame. It is not recommended that FEF parts be adjacent to each other.

One frame is further divided into a number of OFDM symbols and a preamble. As shown in (d), the frame com-

prises a preamble, one or more frame signaling symbols (FSS), normal data symbols and a frame edge symbol (FES).

The preamble is a special symbol that enables fast Future-cast UTB system signal detection and provides a set of basic transmission parameters for efficient transmission and reception of the signal. The detailed description of the preamble will be described later.

The main purpose of the FSS(s) is to carry the PLS data. For fast synchronization and channel estimation, and hence fast decoding of PLS data, the FSS has more dense pilot pattern than the normal data symbol. The FES has exactly the same pilots as the FSS, which enables frequency-only interpolation within the FES and temporal interpolation, without extrapolation, for symbols immediately preceding the FES.

FIG. 11 illustrates a signaling hierarchy structure of the frame according to an embodiment of the present invention.

FIG. 11 illustrates the signaling hierarchy structure, which is split into three main parts: the preamble signaling data **11000**, the PLS1 data **11010** and the PLS2 data **11020**. The purpose of the preamble, which is carried by the preamble symbol in every frame, is to indicate the transmission type and basic transmission parameters of that frame. The PLS1 enables the receiver to access and decode the PLS2 data, which contains the parameters to access the DP of interest. The PLS2 is carried in every frame and split into two main parts: PLS2-STAT data and PLS2-DYN data. The static and dynamic portion of PLS2 data is followed by padding, if necessary.

FIG. 12 illustrates preamble signaling data according to an embodiment of the present invention.

Preamble signaling data carries 21 bits of information that are needed to enable the receiver to access PLS data and trace DPs within the frame structure. Details of the preamble signaling data are as follows:

PHY_PROFILE: This 3-bit field indicates the PHY profile type of the current frame. The mapping of different PHY profile types is given in below table 5.

TABLE 5

Value	PHY profile
000	Base profile
001	Handheld profile
010	Advanced profiled
011~110	Reserved
111	FEF

FFT_SIZE: This 2 bit field indicates the FFT size of the current frame within a frame-group, as described in below table 6.

TABLE 6

Value	FFT size
00	8K FFT
01	16K FFT
10	32K FFT
11	Reserved

GI_FRACTION: This 3 bit field indicates the guard interval fraction value in the current super-frame, as described in below table 7.

19

TABLE 7

Value	GI_FRACTION
000	1/5
001	1/10
010	1/20
011	1/40
100	1/80
101	1/160
110~111	Reserved

EAC_FLAG: This 1 bit field indicates whether the EAC is provided in the current frame. If this field is set to '1', emergency alert service (EAS) is provided in the current frame. If this field set to '0', EAS is not carried in the current frame. This field can be switched dynamically within a super-frame.

PILOT_MODE: This 1-bit field indicates whether the pilot mode is mobile mode or fixed mode for the current frame in the current frame-group. If this field is set to '0', mobile pilot mode is used. If the field is set to '1', the fixed pilot mode is used.

PAPR_FLAG: This 1-bit field indicates whether PAPR reduction is used for the current frame in the current frame-group. If this field is set to value '1', tone reservation is used for PAPR reduction. If this field is set to '0', PAPR reduction is not used.

FRU_CONFIGURE: This 3-bit field indicates the PHY profile type configurations of the frame repetition units (FRU) that are present in the current super-frame. All profile types conveyed in the current super-frame are identified in this field in all preambles in the current super-frame. The 3-bit field has a different definition for each profile, as show in below table 8.

TABLE 8

	Current PHY_PRO- FILE = '000' (base)	Current PHY_PRO- FILE = '001' (handheld)	Current PHY_PRO- FILE = '010' (advanced)	Current PHY_PRO- FILE = '111' (FEF)
FRU_CON- FIGURE = 000	Only base profile present	Only handheld profile present	Only advanced profile present	Only FEF present
FRU_CON- FIGURE = 1XX	Handheld profile present	Base profile present	Base profile present	Base profile present
FRU_CON- FIGURE = X1X	Advanced profile present	Advanced profile present	Handheld profile present	Handheld profile present
FRU_CON- FIGURE = XX1	FEF present	FEF present	FEF present	Advanced profile present

RESERVED: This 7-bit field is reserved for future use.

FIG. 13 illustrates PLS1 data according to an embodiment of the present invention.

PLS1 data provides basic transmission parameters including parameters required to enable the reception and decoding of the PLS2. As above mentioned, the PLS1 data remain unchanged for the entire duration of one frame-group. The detailed definition of the signaling fields of the PLS1 data are as follows:

PREAMBLE_DATA: This 20-bit field is a copy of the preamble signaling data excluding the EAC_FLAG.

NUM_FRAME_FRU: This 2-bit field indicates the number of the frames per FRU.

20

PAYLOAD_TYPE: This 3-bit field indicates the format of the payload data carried in the frame-group.

PAYLOAD_TYPE is signaled as shown in table 9.

TABLE 9

Value	Payload type
1XX	TS stream is transmitted
X1X	IP stream is transmitted
XX1	GS stream is transmitted

NUM_FSS: This 2-bit field indicates the number of FSS symbols in the current frame.

SYSTEM_VERSION: This 8-bit field indicates the version of the transmitted signal format. The SYSTEM_VERSION is divided into two 4-bit fields, which are a major version and a minor version.

Major version: The MSB four bits of SYSTEM_VERSION field indicate major version information. A change in the major version field indicates a non-backward-compatible change. The default value is '0000'. For the version described in this standard, the value is set to '0000'.

Minor version: The LSB four bits of SYSTEM_VERSION field indicate minor version information. A change in the minor version field is backward-compatible.

CELL_ID: This is a 16-bit field which uniquely identifies a geographic cell in an ATSC network. An ATSC cell coverage area may consist of one or more frequencies, depending on the number of frequencies used per Futurecast UTB system. If the value of the CELL_ID is not known or unspecified, this field is set to '0'.

NETWORK_ID: This is a 16-bit field which uniquely identifies the current ATSC network.

SYSTEM_ID: This 16-bit field uniquely identifies the Futurecast UTB system within the ATSC network. The Futurecast UTB system is the terrestrial broadcast system whose input is one or more input streams (TS, IP, GS) and whose output is an RF signal. The Futurecast UTB system carries one or more PHY profiles and FEF, if any. The same Futurecast UTB system may carry different input streams and use different RF frequencies in different geographical areas, allowing local service insertion. The frame structure and scheduling is controlled in one place and is identical for all transmissions within a Futurecast UTB system. One or more Futurecast UTB systems may have the same SYSTEM_ID meaning that they all have the same physical layer structure and configuration.

The following loop consists of FRU_PHY_PROFILE, FRU_FRAME_LENGTH, FRU_GI_FRACTION, and RESERVED which are used to indicate the FRU configuration and the length of each frame type. The loop size is fixed so that four PHY profiles (including a FEF) are signaled within the FRU. If NUM_FRAME_FRU is less than 4, the unused fields are filled with zeros.

FRU_PHY_PROFILE: This 3-bit field indicates the PHY profile type of the (i+1)th (i is the loop index) frame of the associated FRU. This field uses the same signaling format as shown in the table 8.

FRU_FRAME_LENGTH: This 2-bit field indicates the length of the (i+1)th frame of the associated FRU. Using FRU_FRAME_LENGTH together with FRU_GI_FRACTION, the exact value of the frame duration can be obtained.

FRU_GI_FRACTION: This 3-bit field indicates the guard interval fraction value of the (i+1)th frame of the associated FRU. FRU_GI_FRACTION is signaled according to the table 7.

21

RESERVED: This 4-bit field is reserved for future use.

The following fields provide parameters for decoding the PLS2 data.

PLS2_FEC_TYPE: This 2-bit field indicates the FEC type used by the PLS2 protection. The FEC type is signaled according to table 10. The details of the LDPC codes will be described later.

TABLE 10

Contents	PLS2 FEC type
00	4K-1/4 and 7K-3/10 LDPC codes
01~11	Reserved

PLS2_MOD: This 3-bit field indicates the modulation type used by the PLS2. The modulation type is signaled according to table 11.

TABLE 11

Value	PLS2_MODE
000	BPSK
001	QPSK
010	QAM-16
011	NUQ-64
100~111	Reserved

PLS2_SIZE_CELL: This 15-bit field indicates Ctotal_partial_block, the size (specified as the number of QAM cells) of the collection of full coded blocks for PLS2 that is carried in the current frame-group. This value is constant during the entire duration of the current frame-group.

PLS2_STAT_SIZE_BIT: This 14-bit field indicates the size, in bits, of the PLS2-STAT for the current frame-group. This value is constant during the entire duration of the current frame-group.

PLS2_DYN_SIZE_BIT: This 14-bit field indicates the size, in bits, of the PLS2-DYN for the current frame-group. This value is constant during the entire duration of the current frame-group.

PLS2_REP_FLAG: This 1-bit flag indicates whether the PLS2 repetition mode is used in the current frame-group. When this field is set to value '1', the PLS2 repetition mode is activated. When this field is set to value '0', the PLS2 repetition mode is deactivated.

PLS2_REP_SIZE_CELL: This 15-bit field indicates Ctotal_partial_block, the size (specified as the number of QAM cells) of the collection of partial coded blocks for PLS2 carried in every frame of the current frame-group, when PLS2 repetition is used. If repetition is not used, the value of this field is equal to 0. This value is constant during the entire duration of the current frame-group.

PLS2_NEXT_FEC_TYPE: This 2-bit field indicates the FEC type used for PLS2 that is carried in every frame of the next frame-group. The FEC type is signaled according to the table 10.

PLS2_NEXT_MOD: This 3-bit field indicates the modulation type used for PLS2 that is carried in every frame of the next frame-group. The modulation type is signaled according to the table 11.

PLS2_NEXT_REP_FLAG: This 1-bit flag indicates whether the PLS2 repetition mode is used in the next frame-group. When this field is set to value '1', the PLS2 repetition mode is activated. When this field is set to value '0', the PLS2 repetition mode is deactivated.

22

PLS2_NEXT_REP_SIZE_CELL: This 15-bit field indicates Ctotal_full_block, The size (specified as the number of QAM cells) of the collection of full coded blocks for PLS2 that is carried in every frame of the next frame-group, when PLS2 repetition is used. If repetition is not used in the next frame-group, the value of this field is equal to 0. This value is constant during the entire duration of the current frame-group.

PLS2_NEXT_REP_STAT_SIZE_BIT: This 14-bit field indicates the size, in bits, of the PLS2-STAT for the next frame-group. This value is constant in the current frame-group.

PLS2_NEXT_REP_DYN_SIZE_BIT: This 14-bit field indicates the size, in bits, of the PLS2-DYN for the next frame-group. This value is constant in the current frame-group.

PLS2_AP_MODE: This 2-bit field indicates whether additional parity is provided for PLS2 in the current frame-group. This value is constant during the entire duration of the current frame-group. The below table 12 gives the values of this field. When this field is set to '00', additional parity is not used for the PLS2 in the current frame-group.

TABLE 12

Value	PLS2-AP mode
00	AP is not provided
01	AP1 mode
10~11	Reserved

PLS2_AP_SIZE_CELL: This 15-bit field indicates the size (specified as the number of QAM cells) of the additional parity bits of the PLS2. This value is constant during the entire duration of the current frame-group.

PLS2_NEXT_AP_MODE: This 2-bit field indicates whether additional parity is provided for PLS2 signaling in every frame of next frame-group. This value is constant during the entire duration of the current frame-group. The table 12 defines the values of this field

PLS2_NEXT_AP_SIZE_CELL: This 15-bit field indicates the size (specified as the number of QAM cells) of the additional parity bits of the PLS2 in every frame of the next frame-group. This value is constant during the entire duration of the current frame-group.

RESERVED: This 32-bit field is reserved for future use.

CRC_32: A 32-bit error detection code, which is applied to the entire PLS1 signaling.

FIG. 14 illustrates PLS2 data according to an embodiment of the present invention.

FIG. 14 illustrates PLS2-STAT data of the PLS2 data. The PLS2-STAT data are the same within a frame-group, while the PLS2-DYN data provide information that is specific for the current frame.

The details of fields of the PLS2-STAT data are as follows:

FIC_FLAG: This 1-bit field indicates whether the FIC is used in the current frame-group. If this field is set to '1', the FIC is provided in the current frame. If this field set to '0', the FIC is not carried in the current frame. This value is constant during the entire duration of the current frame-group.

AUX_FLAG: This 1-bit field indicates whether the auxiliary stream(s) is used in the current frame-group. If this field is set to '1', the auxiliary stream is provided in the current frame. If this field set to '0', the auxiliary stream is

23

not carried in the current frame. This value is constant during the entire duration of current frame-group.

NUM_DP: This 6-bit field indicates the number of DPs carried within the current frame. The value of this field ranges from 1 to 64, and the number of DPs is NUM_DP+1.

DP_ID: This 6-bit field identifies uniquely a DP within a PHY profile.

DP_TYPE: This 3-bit field indicates the type of the DP. This is signaled according to the below table 13.

TABLE 13

Value	DP Type
000	DP Type 1
001	DP Type 2
010~111	reserved

DP_GROUP_ID: This 8-bit field identifies the DP group with which the current DP is associated. This can be used by a receiver to access the DPs of the service components associated with a particular service, which will have the same DP_GROUP_ID.

BASE_DP_ID: This 6-bit field indicates the DP carrying service signaling data (such as PSI/SI) used in the Management layer. The DP indicated by BASE_DP_ID may be either a normal DP carrying the service signaling data along with the service data or a dedicated DP carrying only the service signaling data.

DP_FEC_TYPE: This 2-bit field indicates the FEC type used by the associated DP. The FEC type is signaled according to the below table 14.

TABLE 14

Value	FEC_TYPE
00	16K LDPC
01	64K LDPC
10~11	Reserved

DP_COD: This 4-bit field indicates the code rate used by the associated DP. The code rate is signaled according to the below table 15.

TABLE 15

Value	Code rate
0000	5/15
0001	6/15
0010	7/15
0011	8/15
0100	9/15
0101	10/15
0110	11/15
0111	12/15
1000	13/15
1001~1111	Reserved

DP_MOD: This 4-bit field indicates the modulation used by the associated DP. The modulation is signaled according to the below table 16.

TABLE 16

Value	Modulation
0000	QPSK
0001	QAM-16
0010	NUQ-64

24

TABLE 16-continued

Value	Modulation
0011	NUQ-256
0100	NUQ-1024
0101	NUC-16
0110	NUC-64
0111	NUC-256
1000	NUC-1024
1001~1111	reserved

DP_SSD_FLAG: This 1-bit field indicates whether the SSD mode is used in the associated DP. If this field is set to value '1', SSD is used. If this field is set to value '0', SSD is not used.

The following field appears only if PHY_PROFILE is equal to '010', which indicates the advanced profile: DP_MIMO: This 3-bit field indicates which type of MIMO encoding process is applied to the associated DP. The type of MIMO encoding process is signaled according to the table 17.

TABLE 17

Value	MIMO encoding
000	FR-SM
001	FRFD-SM
010~111	reserved

DP_TI_TYPE: This 1-bit field indicates the type of time-interleaving. A value of '0' indicates that one TI group corresponds to one frame and contains one or more TI-blocks. A value of '1' indicates that one TI group is carried in more than one frame and contains only one TI-block.

DP_TI_LENGTH: The use of this 2-bit field (the allowed values are only 1, 2, 4, 8) is determined by the values set within the DP_TI_TYPE field as follows:

If the DP_TI_TYPE is set to the value '1', this field indicates PI, the number of the frames to which each TI group is mapped, and there is one TI-block per TI group (NTI=1). The allowed PI values with 2-bit field are defined in the below table 18.

If the DP_TI_TYPE is set to the value '0', this field indicates the number of TI-blocks NTI per TI group, and there is one TI group per frame (Pi=1). The allowed PI values with 2-bit field are defined in the below table 18.

TABLE 18

2-bit field	PI	NTI
00	1	1
01	2	2
10	4	3
11	8	4

DP_FRAME_INTERVAL: This 2-bit field indicates the frame interval (IJUMP) within the frame-group for the associated DP and the allowed values are 1, 2, 4, 8 (the corresponding 2-bit field is '00', '01', '10', or '11', respectively). For DPs that do not appear every frame of the frame-group, the value of this field is equal to the interval between successive frames. For example, if a DP appears on the frames 1, 5, 9, 13, etc., this field is set to '4'. For DPs that appear in every frame, this field is set to '1'.

DP_TI_BYPASS: This 1-bit field determines the availability of time interleaver. If time interleaving is not used for a DP, it is set to '1'. Whereas if time interleaving is used it is set to '0'.

25

DP_FIRST_FRAME_IDX: This 5-bit field indicates the index of the first frame of the super-frame in which the current DP occurs. The value of DP_FIRST_FRAME_IDX ranges from 0 to 31

DP_NUM_BLOCK_MAX: This 10-bit field indicates the maximum value of DP_NUM_BLOCKS for this DP. The value of this field has the same range as DP_NUM_BLOCKS.

DP_PAYLOAD_TYPE: This 2-bit field indicates the type of the payload data carried by the given DP. DP_PAYLOAD_TYPE is signaled according to the below table 19.

TABLE 19

Value	Payload Type
00	TS.
01	IP
10	GS
11	reserved

DP_INBAND_MODE: This 2-bit field indicates whether the current DP carries in-band signaling information. The in-band signaling type is signaled according to the below table 20.

TABLE 20

Value	In-band mode
00	In-band signaling is not carried.
01	INBAND-PLS is carried only
10	INBAND-ISSY is carried only
11	INBAND-PLS and INBAND-ISSY are carried

DP_PROTOCOL_TYPE: This 2-bit field indicates the protocol type of the payload carried by the given DP. It is signaled according to the below table 21 when input payload types are selected.

TABLE 21

Value	If DP_PAYLOAD_TYPE Is TS	If DP_PAYLOAD_TYPE Is IP	If DP_PAYLOAD_TYPE Is GS
00	MPEG2-TS	IPv4	(Note)
01	Reserved	IPv6	Reserved
10	Reserved	Reserved	Reserved
11	Reserved	Reserved	Reserved

DP_CRC_MODE: This 2-bit field indicates whether CRC encoding is used in the Input Formatting block. The CRC mode is signaled according to the below table 22.

TABLE 22

Value	CRC mode
00	Not used
01	CRC-8
10	CRC-16
11	CRC-32

DNP_MODE: This 2-bit field indicates the null-packet deletion mode used by the associated DP when DP_PAYLOAD_TYPE is set to TS ('00'). DNP_MODE is signaled according to the below table 23. If DP_PAYLOAD_TYPE is not TS ('00'), DNP_MODE is set to the value '00'.

26

TABLE 23

Value	Null-packet deletion mode
00	Not used
01	DNP-NORMAL
10	DNP-OFFSET
11	reserved

ISSY_MODE: This 2-bit field indicates the ISSY mode used by the associated DP when DP_PAYLOAD_TYPE is set to TS ('00'). The ISSY_MODE is signaled according to the below table 24 If DP_PAYLOAD_TYPE is not TS ('00'), ISSY_MODE is set to the value '00'.

TABLE 24

Value	ISSY mode
00	Not used
01	ISSY-UP
10	ISSY-BBF
11	reserved

HC_MODE_TS: This 2-bit field indicates the TS header compression mode used by the associated DP when DP_PAYLOAD_TYPE is set to TS ('00'). The HC_MODE_TS is signaled according to the below table 25.

TABLE 25

Value	Header compression mode
00	HC_MODE_TS 1
01	HC_MODE_TS 2
10	HC_MODE_TS 3
11	HC_MODE_TS 4

HC_MODE_IP: This 2-bit field indicates the IP header compression mode when DP_PAYLOAD_TYPE is set to IP ('01'). The HC_MODE_IP is signaled according to the below table 26.

TABLE 26

Value	Header compression mode
00	No compression
01	HC_MODE_IP 1
10~11	reserved

PID: This 13-bit field indicates the PID number for TS header compression when DP_PAYLOAD_TYPE is set to TS ('00') and HC_MODE_TS is set to '01' or '10'.

RESERVED: This 8-bit field is reserved for future use. The following field appears only if FIC_FLAG is equal to '1':

FIC_VERSION: This 8-bit field indicates the version number of the FIC.

FIC_LENGTH_BYTE: This 13-bit field indicates the length, in bytes, of the FIC.

RESERVED: This 8-bit field is reserved for future use. The following field appears only if AUX_FLAG is equal to '1':

NUM_AUX: This 4-bit field indicates the number of auxiliary streams. Zero means no auxiliary streams are used.

AUX_CONFIG_RFU: This 8-bit field is reserved for future use.

AUX_STREAM_TYPE: This 4-bit is reserved for future use for indicating the type of the current auxiliary stream.

AUX_PRIVATE_CONFIG: This 28-bit field is reserved for future use for signaling auxiliary streams.

FIG. 15 illustrates PLS2 data according to another embodiment of the present invention.

FIG. 15 illustrates PLS2-DYN data of the PLS2 data. The values of the PLS2-DYN data may change during the duration of one frame-group, while the size of fields remains constant.

The details of fields of the PLS2-DYN data are as follows:

FRAME_INDEX: This 5-bit field indicates the frame index of the current frame within the super-frame. The index of the first frame of the super-frame is set to '0'.

PLS_CHANGE_COUNTER: This 4-bit field indicates the number of super-frames ahead where the configuration will change. The next super-frame with changes in the configuration is indicated by the value signaled within this field. If this field is set to the value '0000', it means that no scheduled change is foreseen: e.g., value '1' indicates that there is a change in the next super-frame.

FIC_CHANGE_COUNTER: This 4-bit field indicates the number of super-frames ahead where the configuration (i.e., the contents of the FIC) will change. The next super-frame with changes in the configuration is indicated by the value signaled within this field. If this field is set to the value '0000', it means that no scheduled change is foreseen: e.g., value '0001' indicates that there is a change in the next super-frame.

RESERVED: This 16-bit field is reserved for future use.

The following fields appear in the loop over NUM_DP, which describe the parameters associated with the DP carried in the current frame.

DP_ID: This 6-bit field indicates uniquely the DP within a PHY profile.

DP_START: This 15-bit (or 13-bit) field indicates the start position of the first of the DPs using the DPU addressing scheme. The DP_START field has differing length according to the PHY profile and FFT size as shown in the below table 27.

TABLE 27

PHY profile	DP_START field size	
	64K	16K
Base	13 bits	15 bits
Handheld	—	13 bits
Advanced	13 bits	15 bits

DP_NUM_BLOCK: This 10-bit field indicates the number of FEC blocks in the current TI group for the current DP. The value of DP_NUM_BLOCK ranges from 0 to 1023

RESERVED: This 8-bit field is reserved for future use.

The following fields indicate the FIC parameters associated with the EAC.

EAC_FLAG: This 1-bit field indicates the existence of the EAC in the current frame. This bit is the same value as the EAC_FLAG in the preamble.

EAS_WAKE_UP_VERSION_NUM: This 8-bit field indicates the version number of a wake-up indication.

If the EAC_FLAG field is equal to '1', the following 12 bits are allocated for EAC_LENGTH_BYTE field. If the EAC_FLAG field is equal to '0', the following 12 bits are allocated for EAC_COUNTER.

EAC_LENGTH_BYTE: This 12-bit field indicates the length, in byte, of the EAC.

EAC_COUNTER: This 12-bit field indicates the number of the frames before the frame where the EAC arrives.

The following field appears only if the AUX_FLAG field is equal to '1':

AUX_PRIVATE_DYN: This 48-bit field is reserved for future use for signaling auxiliary streams. The meaning of this field depends on the value of AUX_STREAM_TYPE in the configurable PLS2-STAT.

CRC_32: A 32-bit error detection code, which is applied to the entire PLS2.

FIG. 16 illustrates a logical structure of a frame according to an embodiment of the present invention.

As above mentioned, the PLS, EAC, FIC, DPs, auxiliary streams and dummy cells are mapped into the active carriers of the OFDM symbols in the frame. The PLS1 and PLS2 are first mapped into one or more FSS(s). After that, EAC cells, if any, are mapped immediately following the PLS field, followed next by FIC cells, if any. The DPs are mapped next after the PLS or EAC, FIC, if any. Type 1 DPs follows first, and Type 2 DPs next. The details of a type of the DP will be described later. In some case, DPs may carry some special data for EAS or service signaling data. The auxiliary stream or streams, if any, follow the DPs, which in turn are followed by dummy cells. Mapping them all together in the above mentioned order, i.e. PLS, EAC, FIC, DPs, auxiliary streams and dummy data cells exactly fill the cell capacity in the frame.

FIG. 17 illustrates PLS mapping according to an embodiment of the present invention.

PLS cells are mapped to the active carriers of FSS(s). Depending on the number of cells occupied by PLS, one or more symbols are designated as FSS(s), and the number of FSS(s) N_FSS is signaled by NUM_FSS in PLS1. The FSS is a special symbol for carrying PLS cells. Since robustness and latency are critical issues in the PLS, the FSS(s) has higher density of pilots allowing fast synchronization and frequency-only interpolation within the FSS.

PLS cells are mapped to active carriers of the NFSS FSS(s) in a top-down manner as shown in an example in FIG. 17. The PLS1 cells are mapped first from the first cell of the first FSS in an increasing order of the cell index. The PLS2 cells follow immediately after the last cell of the PLS1 and mapping continues downward until the last cell index of the first FSS. If the total number of required PLS cells exceeds the number of active carriers of one FSS, mapping proceeds to the next FSS and continues in exactly the same manner as the first FSS.

After PLS mapping is completed, DPs are carried next. If EAC, FIC or both are present in the current frame, they are placed between PLS and "normal" DPs.

FIG. 18 illustrates EAC mapping according to an embodiment of the present invention.

EAC is a dedicated channel for carrying EAS messages and links to the DPs for EAS. EAS support is provided but EAC itself may or may not be present in every frame. EAC, if any, is mapped immediately after the PLS2 cells. EAC is not preceded by any of the FIC, DPs, auxiliary streams or dummy cells other than the PLS cells. The procedure of mapping the EAC cells is exactly the same as that of the PLS.

The EAC cells are mapped from the next cell of the PLS2 in increasing order of the cell index as shown in the example in FIG. 18. Depending on the EAS message size, EAC cells may occupy a few symbols, as shown in FIG. 18.

EAC cells follow immediately after the last cell of the PLS2, and mapping continues downward until the last cell index of the last FSS. If the total number of required EAC cells exceeds the number of remaining active carriers of the last FSS mapping proceeds to the next symbol and continues

in exactly the same manner as FSS(s). The next symbol for mapping in this case is the normal data symbol, which has more active carriers than a FSS.

After EAC mapping is completed, the FIC is carried next, if any exists. If FIC is not transmitted (as signaled in the PLS2 field), DPs follow immediately after the last cell of the EAC.

FIG. 19 illustrates FIC mapping according to an embodiment of the present invention.

(a) shows an example mapping of FIC cell without EAC and (b) shows an example mapping of FIC cell with EAC.

FIC is a dedicated channel for carrying cross-layer information to enable fast service acquisition and channel scanning. This information primarily includes channel binding information between DPs and the services of each broadcaster. For fast scan, a receiver can decode FIC and obtain information such as broadcaster ID, number of services, and BASE_DP_ID. For fast service acquisition, in addition to FIC, base DP can be decoded using BASE_DP_ID. Other than the content it carries, a base DP is encoded and mapped to a frame in exactly the same way as a normal DP. Therefore, no additional description is required for a base DP. The FIC data is generated and consumed in the Management Layer. The content of FIC data is as described in the Management Layer specification.

The FIC data is optional and the use of FIC is signaled by the FIC_FLAG parameter in the static part of the PLS2. If FIC is used, FIC_FLAG is set to '1' and the signaling field for FIC is defined in the static part of PLS2. Signaled in this field are FIC_VERSION, and FIC_LENGTH_BYTE. FIC uses the same modulation, coding and time interleaving parameters as PLS2. FIC shares the same signaling parameters such as PLS2_MOD and PLS2_FEC. FIC data, if any, is mapped immediately after PLS2 or EAC if any. FIC is not preceded by any normal DPs, auxiliary streams or dummy cells. The method of mapping FIC cells is exactly the same as that of EAC which is again the same as PLS.

Without EAC after PLS, FIC cells are mapped from the next cell of the PLS2 in an increasing order of the cell index as shown in an example in (a). Depending on the FIC data size, FIC cells may be mapped over a few symbols, as shown in (b).

FIC cells follow immediately after the last cell of the PLS2, and mapping continues downward until the last cell index of the last FSS. If the total number of required FIC cells exceeds the number of remaining active carriers of the last FSS, mapping proceeds to the next symbol and continues in exactly the same manner as FSS(s). The next symbol for mapping in this case is the normal data symbol which has more active carriers than a FSS.

If EAS messages are transmitted in the current frame, EAC precedes FIC, and FIC cells are mapped from the next cell of the EAC in an increasing order of the cell index as shown in (b).

After FIC mapping is completed, one or more DPs are mapped, followed by auxiliary streams, if any, and dummy cells.

FIG. 20 illustrates a type of DP according to an embodiment of the present invention.

(a) shows type 1 DP and (b) shows type 2 DP.

After the preceding channels, i.e., PLS, EAC and FIC, are mapped, cells of the DPs are mapped. A DP is categorized into one of two types according to mapping method:

Type 1 DP: DP is mapped by TDM

Type 2 DP: DP is mapped by FDM

The type of DP is indicated by DP_TYPE field in the static part of PLS2. FIG. 20 illustrates the mapping orders of

Type 1 DPs and Type 2 DPs. Type 1 DPs are first mapped in the increasing order of cell index, and then after reaching the last cell index, the symbol index is increased by one. Within the next symbol, the DP continues to be mapped in the increasing order of cell index starting from $p=0$. With a number of DPs mapped together in one frame, each of the Type 1 DPs are grouped in time, similar to TDM multiplexing of DPs.

Type 2 DPs are first mapped in the increasing order of symbol index, and then after reaching the last OFDM symbol of the frame, the cell index increases by one and the symbol index rolls back to the first available symbol and then increases from that symbol index. After mapping a number of DPs together in one frame, each of the Type 2 DPs are grouped in frequency together, similar to FDM multiplexing of DPs.

Type 1 DPs and Type 2 DPs can coexist in a frame if needed with one restriction; Type 1 DPs always precede Type 2 DPs. The total number of OFDM cells carrying Type 1 and Type 2 DPs cannot exceed the total number of OFDM cells available for transmission of DPs:

$$D_{DP1} + D_{DP2} \leq D_{DP} \quad \text{[Equation 2]}$$

where $DDP1$ is the number of OFDM cells occupied by Type 1 DPs, $DDP2$ is the number of cells occupied by Type 2 DPs. Since PLS, EAC, FIC are all mapped in the same way as Type 1 DP, they all follow "Type 1 mapping rule". Hence, overall, Type 1 mapping always precedes Type 2 mapping.

FIG. 21 illustrates DP mapping according to an embodiment of the present invention.

(a) shows an addressing of OFDM cells for mapping type 1 DPs and (b) shows an addressing of OFDM cells for mapping for type 2 DPs.

Addressing of OFDM cells for mapping Type 1 DPs ($0, \dots, DDP1-1$) is defined for the active data cells of Type 1 DPs. The addressing scheme defines the order in which the cells from the TIs for each of the Type 1 DPs are allocated to the active data cells. It is also used to signal the locations of the DPs in the dynamic part of the PLS2.

Without EAC and FIC, address 0 refers to the cell immediately following the last cell carrying PLS in the last FSS. If EAC is transmitted and FIC is not in the corresponding frame, address 0 refers to the cell immediately following the last cell carrying EAC. If FIC is transmitted in the corresponding frame, address 0 refers to the cell immediately following the last cell carrying FIC. Address 0 for Type 1 DPs can be calculated considering two different cases as shown in (a). In the example in (a), PLS, EAC and FIC are assumed to be all transmitted. Extension to the cases where either or both of EAC and FIC are omitted is straightforward. If there are remaining cells in the FSS after mapping all the cells up to FIC as shown on the left side of (a).

Addressing of OFDM cells for mapping Type 2 DPs ($0, \dots, DDP2-1$) is defined for the active data cells of Type 2 DPs. The addressing scheme defines the order in which the cells from the TIs for each of the Type 2 DPs are allocated to the active data cells. It is also used to signal the locations of the DPs in the dynamic part of the PLS2.

Three slightly different cases are possible as shown in (b). For the first case shown on the left side of (b), cells in the last FSS are available for Type 2 DP mapping. For the second case shown in the middle, FIC occupies cells of a normal symbol, but the number of FIC cells on that symbol is not larger than CFSS. The third case, shown on the right side in (b), is the same as the second case except that the number of FIC cells mapped on that symbol exceeds CFSS.

The extension to the case where Type 1 DP(s) precede Type 2 DP(s) is straightforward since PLS, EAC and FIC follow the same “Type 1 mapping rule” as the Type 1 DP(s).

A data pipe unit (DPU) is a basic unit for allocating data cells to a DP in a frame.

A DPU is defined as a signaling unit for locating DPs in a frame. A Cell Mapper **7010** may map the cells produced by the TIs for each of the DPs. A Time interleaver **5050** outputs a series of TI-blocks and each TI-block comprises a variable number of XFECBLOCKs which is in turn composed of a set of cells. The number of cells in an XFECBLOCK, N_{cells} , is dependent on the FECBLOCK size, N_{ldpc} , and the number of transmitted bits per constellation symbol. A DPU is defined as the greatest common divisor of all possible values of the number of cells in a XFECBLOCK, N_{cells} , supported in a given PHY profile. The length of a DPU in cells is defined as LDPU. Since each PHY profile supports different combinations of FECBLOCK size and a different number of bits per constellation symbol, LDPU is defined on a PHY profile basis.

FIG. 22 illustrates an FEC structure according to an embodiment of the present invention.

FIG. 22 illustrates an FEC structure according to an embodiment of the present invention before bit interleaving. As above mentioned, Data FEC encoder may perform the FEC encoding on the input BBF to generate FECBLOCK procedure using outer coding (BCH), and inner coding (LDPC). The illustrated FEC structure corresponds to the FECBLOCK. Also, the FECBLOCK and the FEC structure have same value corresponding to a length of LDPC code-word.

The BCH encoding is applied to each BBF (K_{bch} bits), and then LDPC encoding is applied to BCH-encoded BBF (K_{ldpc} bits= N_{bch} bits) as illustrated in FIG. 22.

The value of N_{ldpc} is either 64800 bits (long FECBLOCK) or 16200 bits (short FECBLOCK).

The below table 28 and table 29 show FEC encoding parameters for a long FECBLOCK and a short FECBLOCK, respectively.

TABLE 28

LDPC Rate	N_{ldpc}	K_{ldpc}	K_{bch}	BCH error correction capability	$N_{bch} - K_{bch}$
5/15	64800	21600	21408	12	192
6/15		25920	25728		
7/15		30240	30048		
8/15		34560	34368		
9/15		38880	38688		
10/15		43200	43008		
11/15		47520	47328		
12/15		51840	51648		
13/15		56160	55968		

TABLE 29

LDPC Rate	N_{ldpc}	K_{ldpc}	K_{bch}	BCH error correction capability	$N_{bch} - K_{bch}$
5/15	16200	5400	5232	12	168
6/15		6480	6312		
7/15		7560	7392		
8/15		8640	8472		
9/15		9720	9552		
10/15		10800	10632		
11/15		11880	11712		

TABLE 29-continued

LDPC Rate	N_{ldpc}	K_{ldpc}	K_{bch}	BCH error correction capability	$N_{bch} - K_{bch}$
12/15		12960	12792		
13/15		14040	13872		

The details of operations of the BCH encoding and LDPC encoding are as follows:

A 12-error correcting BCH code is used for outer encoding of the BBF. The BCH generator polynomial for short FECBLOCK and long FECBLOCK are obtained by multiplying together all polynomials.

LDPC code is used to encode the output of the outer BCH encoding. To generate a completed B_{ldpc} (FECBLOCK), P_{ldpc} (parity bits) is encoded systematically from each I_{ldpc} (BCH-encoded BBF), and appended to I_{ldpc} . The completed B_{ldpc} (FECBLOCK) are expressed as follow Equation.

$$B_{ldpc} I_{ldpc} P_{ldpc} = [i_0, i_1, \dots, i_{K_{ldpc}-1}, p_0, p_1, \dots, p_{N_{ldpc}-K_{ldpc}-1}] \quad \text{[Equation 3]}$$

The parameters for long FECBLOCK and short FECBLOCK are given in the above table 28 and 29, respectively.

The detailed procedure to calculate $N_{ldpc}-K_{ldpc}$ parity bits for long FECBLOCK, is as follows:

1) Initialize the parity bits,

$$p_0 = p_1 = p_2 = \dots = p_{N_{ldpc}-K_{ldpc}-1} = 0 \quad \text{[Equation 4]}$$

2) Accumulate the first information bit— i_0 , at parity bit addresses specified in the first row of an addresses of parity check matrix. The details of addresses of parity check matrix will be described later. For example, for rate 13/15:

$$p_{983} = p_{983} \oplus i_0, p_{2815} = p_{2815} \oplus i_0$$

$$p_{4837} = p_{4837} \oplus i_0, p_{4989} = p_{4989} \oplus i_0$$

$$p_{6138} = p_{6138} \oplus i_0, p_{6458} = p_{6458} \oplus i_0$$

$$p_{6921} = p_{6921} \oplus i_0, p_{6974} = p_{6974} \oplus i_0$$

$$p_{7572} = p_{7572} \oplus i_0, p_{8260} = p_{8260} \oplus i_0$$

$$p_{8496} = p_{8496} \oplus i_0 \quad \text{[Equation 5]}$$

3) For the next 359 information bits, is, $s=1, 2, \dots, 359$ accumulate is at parity bit addresses using following Equation.

$$\{x+(s \bmod 360) \times Q_{ldpc}\} \bmod (N_{ldpc}-K_{ldpc}) \quad \text{[Equation 6]}$$

where x denotes the address of the parity bit accumulator corresponding to the first bit i_0 , and Q_{ldpc} is a code rate dependent constant specified in the addresses of parity check matrix. Continuing with the example, $Q_{ldpc}=24$ for rate 13/15, so for information bit i_1 , the following operations are performed:

$$p_{1007} = p_{1007} \oplus i_1, p_{2839} = p_{2839} \oplus i_1$$

$$p_{4861} = p_{4861} \oplus i_1, p_{5013} = p_{5013} \oplus i_1$$

$$p_{6162} = p_{6162} \oplus i_1, p_{6482} = p_{6482} \oplus i_1$$

$$p_{6945} = p_{6945} \oplus i_1, p_{6998} = p_{6998} \oplus i_1$$

$$p_{7596} = p_{7596} \oplus i_1, p_{8284} = p_{8284} \oplus i_1$$

$$p_{8520} = p_{8520} \oplus i_1 \quad \text{[Equation 7]}$$

4) For the 361st information bit i_{360} , the addresses of the parity bit accumulators are given in the second row of the

33

addresses of parity check matrix. In a similar manner the addresses of the parity bit accumulators for the following 359 information bits is, $s=361, 362, \dots, 719$ are obtained using the Equation 6, where x denotes the address of the parity bit accumulator corresponding to the information bit $i360$, i.e., the entries in the second row of the addresses of parity check matrix.

5) In a similar manner, for every group of 360 new information bits, a new row from addresses of parity check matrixes used to find the addresses of the parity bit accumulators.

After all of the information bits are exhausted, the final parity bits are obtained as follows:

6) Sequentially perform the following operations starting with $i=1$

$$p_i = p_i \oplus p_{i-1}, i=1, 2, \dots, N_{ldpc} - K_{ldpc} - 1 \quad [\text{Equation 8}]$$

where final content of p_i , $i=0, 1, \dots, N_{ldpc} - K_{ldpc} - 1$ is equal to the parity bit p_i .

TABLE 30

Code Rate	Qldpc
5/15	120
6/15	108
7/15	96
8/15	84
9/15	72
10/15	60
11/15	48
12/15	36
13/15	24

This LDPC encoding procedure for a short FECBLOCK is in accordance with t LDPC encoding procedure for the long FECBLOCK, except replacing the table 30 with table 31, and replacing the addresses of parity check matrix for the long FECBLOCK with the addresses of parity check matrix for the short FECBLOCK.

TABLE 31

Code Rate	Qldpc
5/15	30
6/15	27
7/15	24
8/15	21
9/15	18
10/15	15
11/15	12
12/15	9
13/15	6

FIG. 23 illustrates a bit interleaving according to an embodiment of the present invention.

The outputs of the LDPC encoder are bit-interleaved, which consists of parity interleaving followed by Quasi-Cyclic Block (QCB) interleaving and inner-group interleaving.

shows Quasi-Cyclic Block (QCB) interleaving and (b) shows inner-group interleaving.

The FECBLOCK may be parity interleaved. At the output of the parity interleaving, the LDPC codeword consists of 180 adjacent QC blocks in a long FECBLOCK and 45 adjacent QC blocks in a short FECBLOCK. Each QC block in either a long or short FECBLOCK consists of 360 bits. The parity interleaved LDPC codeword is interleaved by QCB interleaving. The unit of QCB interleaving is a QC block. The QC blocks at the output of parity interleaving are

34

permuted by QCB interleaving as illustrated in FIG. 23, where $N_{cells}=64800/\eta \text{ mod}$ or $16200/\eta \text{ mod}$ according to the FECBLOCK length. The QCB interleaving pattern is unique to each combination of modulation type and LDPC code rate.

After QCB interleaving, inner-group interleaving is performed according to modulation type and order ($\eta \text{ mod}$) which is defined in the below table 32. The number of QC blocks for one inner-group, NQCB_IG, is also defined.

TABLE 32

Modulation type	$\eta \text{ mod}$	NQCB_IG
QAM-16	4	2
NUC-16	4	4
NUQ-64	6	3
NUC-64	6	6
NUQ-256	8	4
NUC-256	8	8
NUQ-1024	10	5
NUC-1024	10	10

The inner-group interleaving process is performed with NQCB_IG QC blocks of the QCB interleaving output. Inner-group interleaving has a process of writing and reading the bits of the inner-group using 360 columns and NQCB_IG rows. In the write operation, the bits from the QCB interleaving output are written row-wise. The read operation is performed column-wise to read out m bits from each row, where m is equal to 1 for NUC and 2 for NUQ.

FIG. 24 illustrates a cell-word demultiplexing according to an embodiment of the present invention.

shows a cell-word demultiplexing for 8 and 12 bpcu MIMO and (b) shows a cell-word demultiplexing for 10 bpcu MIMO.

Each cell word $(c_{0,1}, c_{1,1}, \dots, c_{\eta \text{ mod}-1,1})$ of the bit interleaving output is demultiplexed into $(d_{1,0,m}, d_{1,1,m}, \dots, d_{1,\eta \text{ mod}-1,m})$ and $(d_{2,0,m}, d_{2,1,m}, \dots, d_{2,\eta \text{ mod}-1,m})$ as shown in (a), which describes the cell-word demultiplexing process for one XFECBLOCK.

For the 10 bpcu MIMO case using different types of NUQ for MIMO encoding, the Bit Interleaver for NUQ-1024 is re-used. Each cell word $(c_{0,1}, c_{1,1}, \dots, c_{9,1})$ of the Bit Interleaver output is demultiplexed into $(d_{1,0,m}, d_{1,1,m}, \dots, d_{1,3,m})$ and $(d_{2,0,m}, d_{2,1,m}, \dots, d_{2,5,m})$, as shown in (b).

FIG. 25 illustrates a time interleaving according to an embodiment of the present invention.

(a) to (c) show examples of TI mode.

The time interleaver operates at the DP level. The parameters of time interleaving (TI) may be set differently for each DP.

The following parameters, which appear in part of the PLS2-STAT data, configure the TI:

DP_TI_TYPE (allowed values: 0 or 1): Represents the TI mode; '0' indicates the mode with multiple TI blocks (more than one TI block) per TI group. In this case, one TI group is directly mapped to one frame (no inter-frame interleaving). '1' indicates the mode with only one TI block per TI group. In this case, the TI block may be spread over more than one frame (inter-frame interleaving).

DP_TI_LENGTH: If DP_TI_TYPE='0', this parameter is the number of TI blocks NTI per TI group. For DP_TI_TYPE='1', this parameter is the number of frames PI spread from one TI group.

DP_NUM_BLOCK_MAX (allowed values: 0 to 1023): Represents the maximum number of XFECBLOCKs per TI group.

DP_FRAME_INTERVAL (allowed values: 1, 2, 4, 8): Represents the number of the frames IJUMP between two successive frames carrying the same DP of a given PHY profile.

DP_TI_BYPASS (allowed values: 0 or 1): If time interleaving is not used for a DP, this parameter is set to '1'. It is set to '0' if time interleaving is used.

Additionally, the parameter DP_NUM_BLOCK from the PLS2-DYN data is used to represent the number of XFECBLOCKS carried by one TI group of the DP.

When time interleaving is not used for a DP, the following TI group, time interleaving operation, and TI mode are not considered. However, the Delay Compensation block for the dynamic configuration information from the scheduler will still be required. In each DP, the XFECBLOCKS received from the SSD/MIMO encoding are grouped into TI groups. That is, each TI group is a set of an integer number of XFECBLOCKS and will contain a dynamically variable number of XFECBLOCKS. The number of XFECBLOCKS in the TI group of index n is denoted by $N_{xBLOCK_Group}(n)$ and is signaled as DP_NUM_BLOCK in the PLS2-DYN data. Note that $N_{xBLOCK_Group}(n)$ may vary from the minimum value of 0 to the maximum value $N_{xBLOCK_Group_MAX}$ (corresponding to DP_NUM_BLOCK_MAX) of which the largest value is 1023.

Each TI group is either mapped directly onto one frame or spread over PI frames. Each TI group is also divided into more than one TI blocks (NTI), where each TI block corresponds to one usage of time interleaver memory. The TI blocks within the TI group may contain slightly different numbers of XFECBLOCKS. If the TI group is divided into multiple TI blocks, it is directly mapped to only one frame. There are three options for time interleaving (except the extra option of skipping the time interleaving) as shown in the below table 33.

TABLE 33

Mode	Description
Option-1	Each TI group contains one TI block and is mapped directly to one frame as shown in (a). This option is signaled in the PLS2-STAT by DP_TI_TYPE = '0' and DP_TI_LENGTH = '1' ($N_{TI} = 1$).
Option-2	Each TI group contains one TI block and is mapped to more than one frame. (b) shows an example, where one TI group is mapped to two frames, i.e., DP_TI_LENGTH = '2' ($P_f = 2$) and DP_FRAME_INTERVAL (IJUMP = 2). This provides greater time diversity for low data-rate services. This option is signaled in the PLS2-STAT by DP_TI_TYPE = '1'.
Option-3	Each TI group is divided into multiple TI blocks and is mapped directly to one frame as shown in (c). Each TI block may use full TI memory, so as to provide the maximum bit-rate for a DP. This option is signaled in the PLS2-STAT signaling by DP_TI_TYPE = '0' and DP_TI_LENGTH = NTI, while $P_f = 1$.

In each DP, the TI memory stores the input XFECBLOCKS (output XFECBLOCKS from the SSD/MIMO encoding block). Assume that input XFECBLOCKS are defined as

$$(d_{n,s,0,0}, d_{n,s,0,1}, \dots, d_{n,s,0,N_{cells}-1}, \\ d_{n,s,1,0}, \dots, d_{n,s,1,N_{cells}-1}, \dots, d_{n,s,N_{xBLOCK_TI}(n,s)-1,0}, \\ d_{n,s,N_{xBLOCK_TI}(n,s)-1,N_{cells}-1}),$$

where $d_{n,s,r,q}$ is the qth cell of the rth XFECBLOCK in the sth TI block of the nth TI group and represents the outputs of SSD and MIMO encodings as follows

$$d_{n,s,r,q} = \begin{cases} f_{n,s,r,q}, & \text{the output of SSD... encoding} \\ g_{n,s,r,q}, & \text{the output of MIMO encoding} \end{cases}$$

In addition, assume that output XFECBLOCKS from the time interleaver 5050 are defined as

$$(h_{n,s,0}, h_{n,s,1}, \dots, h_{n,s,i}, \dots, h_{n,s,N_{xBLOCK_TI}(n,s) \times N_{cells}-1}),$$

where $h_{n,s,i}$ is the ith output cell (for $i=0, \dots, N_{xBLOCK_TI}(n,s) \times N_{cells}-1$) in the sth TI block of the nth TI group.

Typically, the time interleaver will also act as a buffer for DP data prior to the process of frame building. This is achieved by means of two memory banks for each DP. The first TI-block is written to the first bank. The second TI-block is written to the second bank while the first bank is being read from and so on.

The TI is a twisted row-column block interleaver. For the sth TI block of the nth TI group, the number of rows N_r of a TI memory is equal to the number of cells N_{cells} , i.e., $N_r = N_{cells}$ while the number of columns N_c is equal to the number $N_{xBLOCK_TI}(n,s)$.

FIG. 26 illustrates a basic operation of a twisted row-column block interleaver according to an exemplary embodiment of the present invention.

FIG. 26A illustrates a writing operation in a time interleaver and FIG. 26B illustrates a reading operation in the time interleaver. As illustrated in FIG. 26A, a first XFECBLOCK is written in a first column of a time interleaving memory in a column direction and a second XFECBLOCK is written in a next column, and such an operation is continued. In addition, in an interleaving array, a cell is read in a diagonal direction. As illustrated in FIG. 26B, while the diagonal reading is in progress from a first row (to a right side along the row starting from a leftmost column) to a last row, N_v cells are read. In detail, when it is assumed that $z_{n,s,i}$ ($i=0, \dots, N_r N_c$) is a time interleaving memory cell position to be sequentially read, the reading operation in the interleaving array is executed by calculating a row index $R_{n,s,i}$, a column index $C_{n,s,i}$, and associated twist parameter $T_{n,s,i}$ as shown in an equation given below.

$$\text{GENERATE}(R_{n,s,i}, C_{n,s,i}) = \quad \text{[Equation 9]}$$

$$\{ \\ R_{n,s,i} = \text{mod}(i, N_r), \\ T_{n,s,i} = \text{mod}(S_{shift} \times R_{n,s,i}, N_c), \\ C_{n,s,i} = \text{mod}\left(T_{n,s,i} + \left\lfloor \frac{i}{N_r} \right\rfloor, N_c\right) \\ \}$$

Where, S_{shift} is a common shift value for a diagonal reading process regardless of $N_{xBLOCK_TI}(n,s)$ and the shift value is decided by $N_{xBLOCK_TI_MAX}$ given in PLS2-STAT as shown in an equation given below.

$$\text{for } \begin{cases} N'_{xBLOCK_TI_MAX} = N_{xBLOCK_TI_MAX} + 1, & \text{if } N_{xBLOCK_TI_MAX} \bmod 2 = 0 \\ N'_{xBLOCK_TI_MAX} = N_{xBLOCK_TI_MAX}, & \text{if } N_{xBLOCK_TI_MAX} \bmod 2 = 1 \end{cases} \quad \text{[Equation 10]}$$

$$S_{shift} = \frac{N'_{xBLOCK_TI_MAX} - 1}{2}$$

Consequently, the cell position to be read is calculated by a coordinate $z_{n,s,i} = N_j C_{n,s,i} + R_{n,s,i}$.

FIG. 27 illustrates an operation of a twisted row-column block interleaver according to another exemplary embodiment of the present invention.

In more detail, FIG. 27 illustrates an interleaving array in the time interleaving memory for respective time interleaving groups including a virtual XFECBLOCK when $N_{xBLOCK_TI}(0,0)=3$, $N_{xBLOCK_TI}(1,0)=6$, and $N_{xBLOCK_TI}(2,0)=5$.

A variable $N_{xBLOCK_TI}(n,s) = N_r$ will be equal to or smaller than $N_{xBLOCK_TI_MAX}$. Accordingly, in order for a receiver to achieve single memory interleaving regardless of $N_{xBLOCK_TI}(n,s)$, the size of the interleaving array for the twisted row-column block interleaver is set to a size of $N_r \times N_c = N_{cells} \times N_{xBLOCK_TI_MAX}$ by inserting the virtual XFECBLOCK into the time interleaving memory and a reading process is achieved as shown in an equation given below.

$$\begin{aligned} & p = 0; \\ & \text{for } i = 0; i < N_{cells} N_{xBLOCK_TI_MAX}; i = i + 1 \\ & \quad \{ \text{GENERATE } (R_{n,s,i}, C_{n,s,i}); \\ & \quad V_i = N_r C_{n,s,j} + R_{n,s,j} \\ & \quad \quad \text{if } V_i < N_{cells} N_{xBLOCK_TI}(n,s) \\ & \quad \quad \quad \{ \\ & \quad \quad \quad \quad Z_{n,s,p} = V_i; p = p + 1; \\ & \quad \quad \quad \quad \} \\ & \quad \} \end{aligned} \quad \text{[Equation 11]}$$

The number of the time interleaving groups is set to 3. An option of the time interleaver is signaled in the PLS2-STAT by DP_TI_TYPE='0', DP_FRAME_INTERVAL='1', and DP_TI_LENGTH='1', that is, NTI=1, IJUMP=1, and PI=1. The number of respective XFECBLOCKs per time interleaving group, of which Ncells=30 is signaled in PLS2-DYN data by $N_{xBLOCK_TI}(0,0)=3$, $N_{xBLOCK_TI}(1,0)=6$, and $N_{xBLOCK_TI}(2,0)=5$ of the respective XFECBLOCKs. The maximum number of XFECBLOCKs is signaled in the PLS2-STAT data by $N_{xBLOCK_Group_MAX}$ and this is continued to $\lfloor N_{xBLOCK_Group_MAX} / N_{TI} \rfloor = N_{xBLOCK_TI_MAX} = 6$.

FIG. 28 illustrates a diagonal reading pattern of the twisted row-column block interleaver according to the exemplary embodiment of the present invention.

In more detail, FIG. 28 illustrates a diagonal reading pattern from respective interleaving arrays having parameters $N_{xBLOCK_TI_MAX}=7$ and $S_{shift}=(7-1)/2=3$. In this case, during a reading process expressed by a pseudo code given above, when $V_i \geq N_{cells} N_{xBLOCK_TI}(n,s)$, a value of V_i is omitted and a next calculation value of V_i is used.

FIG. 29 illustrates XFECBLOCK interleaved from each interleaving array according to an exemplary embodiment of the present invention.

FIG. 29 illustrates XFECBLOCK interleaved from each interleaving array having parameters $N_{xBLOCK_TI_MAX}=7$ and $S_{shift}=3$ according to an exemplary embodiment of the present invention.

In this document, the DP can be called a Physical Layer Pipe (PLP), and the PLS information can be called Layer 1 (L1) information or L1 signaling information. The PLS1 information can be called L1 basic information, and the PLS2 information can be called L1 detail information. In this document, signaling specific information/data indicates transmitting and receiving the corresponding information/data through L1 signaling information.

FIG. 30 illustrates a structure of a broadcast signal transmitter according to another embodiment of the present invention.

The broadcast signal transmitter of FIG. 30 comprises an input formatting block 30010, a BICM (Bit Interleaved and Coded Modulation) block 30020, a framing & interleaving block 30030, and a waveform generating block 30040. The framing & interleaving block of FIG. 30 corresponds to the frame building block of FIG. 1, and the waveform generating block 30040 corresponds to the OFDM generating block of FIG. 1.

Different from the embodiments described above, FIG. 30 assumes that the framing building block 1020 comprises a time interleaving block 30050, and accordingly, the frame building block 1020 can be called a framing/interleaving block 30050. In other words, the framing/interleaving block 30030 can further comprise a time interleaving block 30050, a framing block 30060, and a frequency interleaving block 30070. The framing/interleaving block 30030 performs time interleaving on data by using the sub-blocks above, generates a signal frame by mapping the data, and performs frequency interleaving.

Except that the time interleaving block 30050 is incorporated into the framing & interleaving block 30030 from the BICM block 30020, other descriptions are the same as given above. The waveform generating block 30040 is the same block as the OFDM generating block 1030 of FIG. 1, only differing in the name.

In the same way for the receiver, the time deinterleaving block is incorporated into the frame parsing block 9010 from the demapping and decoding block 9020 of FIG. 9, and the frame parsing block 9010 can be called a frame parsing & deinterleaving block. The frame parsing block 9010 can perform frequency deinterleaving, frame parsing, and time deinterleaving on a received signal.

FIG. 30 renames the sub-blocks of the system by only changing the inclusion relationship among the sub-blocks, and descriptions about specific operations thereof are the same as given above. In this document, constituting elements of the transmitter and receiver system can be called not only blocks but also modules or units.

In FIG. 30, the framing module 31060 generates a signal frame. In what follows, a method for configuring a signal frame according to an embodiment of the present invention will be described in detail.

FIG. 31 illustrates a signal frame structure according to one embodiment of the present invention.

A signal frame comprises a bootstrap, a preamble, and a data part.

A bootstrap signal is designed to be robust so that it can operate normally still in a harsh environment. The bootstrap signal transmits essential system information and essential information by which the corresponding broadcast system can be accessed.

The bootstrap signal can be used to lock RF carrier frequency and perform offset estimation; and to lock sampling frequency and perform offset estimation. The bootstrap signal can be used for signaling system bandwidth information (6, 7, 8 MHz). Also, the bootstrap signal can convey core system signaling information (for example, major or minor version information). Also, the bootstrap information may signal the start timing of the next data frame. Also, the bootstrap information may transmit identifiers for L1 signaling information conveyed in the preamble. Also, the bootstrap signal can support an Emergency Alert System (EAS) wake-up function. The EAS wake-up information of the bootstrap signal indicates outbreak of an emergency situation. In other words, the EAS information can indicate whether emergency alert information from the EAS or other sources is present in at least one frame.

FIG. 32 illustrates a signal frame structure according to one embodiment of the present invention.

FIG. 32 illustrates the signal frame of FIG. 31 on the basis of symbol units. The preamble and data can have at least one symbol, respectively.

The preamble conveys L1 signaling information. And the preamble can include one or multiple OFDM symbols according to the size of the L1 signaling information, namely the number of bits. The preamble can have the same or different structure from the data symbol (FFT size, Guard Interval (GI), and so on). In this case, the bootstrap can signal the structure of the preamble symbol or data symbol. In other words, the bootstrap may indicate the FFT size, GI length, or pilot pattern of the preamble.

Advantages obtained as the bootstrap transmits information about the preamble/data part are as follows. First of all, the operation of a receiver can be simplified. And the time required for obtaining L1 signaling information can be reduced; thus, service acquisition time including channel scan can be reduced. And FFT in a harsh channel environment can be performed in a robust manner or the possibility of GI false detection is reduced, whereby the receiver performance can be improved.

FIG. 33 illustrates a signal frame structure according to one embodiment of the present invention.

FIG. 33 illustrates an embodiment of a single FFT frame which supports only one FFT size within the frame. In other words, all of data symbols can be OFDM modulated according to a single FFT size. However, although the preamble symbol can have the same FFT/GI structure as that for the data symbol, the preamble symbol can still allow a different FFT/GI structure from that for the data symbol. The structure of the preamble symbol can be fixed or signaled by a bootstrap signal.

In such a frame structure, at the first and the last symbol of the frame, discontinuity of symbol or symbol structure can occur at the frame boundary. Due to the discontinuity, channel estimation performance and sync tracking performance may be degraded. Therefore, to supplement the performance degradation, the present invention proposes an additional structure of both frame edge symbols.

(1) First Edge Symbol Structure

The carrier separation of Scattered Pilot (SP) with respect to the edge symbol can be set by the D_x value of the SP of the data symbol. The D_x value represents distance or separation of pilot bearing carriers from each other along fre-

quency direction. It should be noted that D_y represents the number of symbols forming one scattered pilot sequence along time direction.

In other words, the carrier separation of pilots of a subframe boundary symbol can be determined by the D_x value. For example, if D_x is 3, those cells carrier indices of which are a multiple of 3 can be subframe boundary pilots. For the relative carrier indices k , those cells of a subframe boundary symbol where $k \bmod D_x = 0$ can be the subframe boundary pilots.

The SP pattern of data symbols is defined by D_x and D_y . For example, if the SP pattern of the data symbol is such that $D_x = 4$ and $D_y = 2$, there are three carriers between pilot bearing carriers, and a fourth carrier following the pilot carrying carriers convey the SP. However, on the basis of a single symbol, the pilot is separated by $D_x * D_y$. On the contrary, pilots are separated from each other by D_x for the subframe boundary symbol; therefore, the subframe boundary symbol can have more pilots than the data symbol if one symbol is used as the unit. Also, more pilots are located at the same SP locations of following data symbols. Therefore, a receiver can improve channel estimation/sync tracking performance for following symbols on the basis of the subframe boundary symbol.

In this case, since D_x information of the data symbol is not available when the receiver obtains the initial signal, the bootstrap may deliver the D_x information. As an example, the D_x information may be transmitted in two ways: D_x information (3 bits, 8 types {3, 6, 12, 24, 4, 8, 16, 32}) and FFT/GI (FFT 2 bits, GI 4 bits).

(2) Second Edge Symbol Structure

In case the bootstrap does not transmit SP D_x information of the data symbol of the corresponding frame, the separating distance of the SP of an edge symbol following the bootstrap can be fixed to a D_x basis value rather than the D_x value. If the corresponding broadcast system uses a single D_x basis value, it can be fixed; however, in the case of multiple D_x basis values, the bootstrap may transmit the information which determines the D_x basis value. For example, if D_x is 3, 6, 12, 24, the D_x basis value is 3. If D_x is 4, 8, 16, 32, the D_x basis value becomes 4. In case an SP pattern is formed, the D_x basis value represents a D_x value which acts as the basis for D_x extension.

As an example, the D_x information can be transmitted as GI information and D_x basis information (for example, it can be 1 bit and if $D_x = 3$, it is 0 or if $D_x = 4$, it is 1).

In case the preamble has the same FFT size as the data symbol, one or multiple preamble symbols may perform the role of the edge symbol. FIG. 33 illustrates the case where the preamble symbol has the same FFT size as the data symbol, and the preamble symbol also performs the role of the edge symbol.

The structures of the edge symbol described above exhibit advantages and disadvantages. In the case of the first edge symbol structure, since the pilot overhead is relatively small, transmission and reception efficiency is considered to be excellent. In the case of the second edge symbol structure, transmission and reception efficiency is decreased as pilots more than necessary are used, but the second edge symbol structure is more advantageous in terms of channel estimation and sync tracking performance using the pilots.

Since the preamble is located at the start of a frame or a subframe, the preamble can be configured to have the edge symbol structure. Embodiments of the edge symbol structure described above may be operated selectively by signaling the corresponding type. The edge symbol structure is not

limited to the scattered pilot separation, but can be operated selectively by adding a signaling bit even for a Continual Pilot (CP) case.

In case the CP is used additionally, the pilot overhead is increased, but channel estimation and sync tracking performance between frames or sub-frames may be increased. When the CP is not additionally used, the pilot overhead is decreased, but channel estimation and sync tracking performance may be degraded a little.

Information about the structure of the edge symbol is conveyed in the bootstrap in the case of a preamble edge symbol and is conveyed in the preamble in the case of a data edge symbol. And the receiver can obtain information about the preamble edge symbol structure by decoding the bootstrap and obtain information about the data edge symbol structure by decoding the preamble.

As an example, in the case of the preamble, the edge symbol structure of the preamble can be defined flexibly in the bootstrap. And the receiver, by obtaining the corresponding signaling information, can process a received signal by correctly distinguishing the pilot carrier position and the data carrier position of the preamble.

The edge symbol structure information can be transmitted after the edge SP mode information (edge_SP_mode; 2 bit) and edge CP mode information (edge_CP_mode; 1 bit) are defined. For example, if the edge SP mode information is 0, it indicates the first edge symbol structure; in the case of 1, the second edge symbol structure; in the case of 2, the data symbol structure; and in the case of 3, it indicates a reserved bit.

In case the value of the edge SP mode information is 2, it indicates that the edge symbol structure is not used for the edge symbol part, but a normal data symbol structure is used. In other words, the aforementioned case indicates the case where the edge symbol has the same pilot pattern as the data part. In this case, it is advantageous in terms of the pilot overhead and can be used for such a situation that the channel estimation/sync tracking performance is not important or the receiver is designed not to take into account time interpolation at the time of channel estimation.

The edge SP mode information may also be called edge symbol mode information or subframe boundary symbol mode information. If the value of the edge SP mode information is 0 or 1, it indicates that the symbol of the edge symbol position has the edge symbol structure; on the other hand, if the edge SP mode information value is 2, it indicates that the symbol of the edge symbol position does not have the edge symbol structure. Therefore, the edge symbol mode information can indicate whether the first or the last symbol of a frame/subframe is an edge symbol or not.

If a broadcast system supports only two of the three cases, the amount of information can be represented and signaled by a single bit. In case multiple edge symbols are present in a frame, signaling can be performed separately for each edge symbol, or multiple edge symbols can be signaled simultaneously while the number of signaling bits is reduced.

In case the bootstrap signals the edge symbol structure of the preamble, signaling can be performed by using the edge SP mode information or the edge CP mode information as described above. Similarly, the edge symbol structure may be specified by using a particular combination of the bits of a preamble structure indicator (7 bits) included in the bootstrap.

FIG. 34 illustrates a signal frame structure according to one embodiment of the present invention.

Different from FIG. 33, FIG. 34 illustrates the case where the first symbol after the preamble symbol performs the role

of the edge symbol. As an example, in the case where the FFT size of the preamble is different from that of the data symbol, the signal structure as shown in FIG. 34 can be used. For the structure of the edge symbol and signaling method, the methods described with reference to FIG. 33 can be applied.

In FIG. 34, the edge symbols of the data part rather than the preamble may be called a frame starting symbol, frame starting signaling symbol, and frame closing/ending symbol depending on their locations. As described above, the signaling information transmitted to the preamble can include the edge SP mode information and edge CP mode information.

FIG. 35 illustrates a signal frame structure according to one embodiment of the present invention.

FIG. 35 illustrates layers of a first signal frame according to an embodiment of the present invention.

Referring to the first signal frame structure, a super frame is defined at the highest position of the hierarchy. The super frame includes a plurality of Frame Repetition Units (FRUs). An FRU comprises a plurality of signal frames, and each signal frame inside the FRU can transmit one signal frame from among defined frame types or a Future Extension Frame (FEF).

The frame type inside the FRU or arrangement of the FEF can be repeated in the same manner within the super frame. The reason for using the FRU unit above is to ensure flexibility and at the same time, to minimize signaling overhead in signaling a super frame structure. The number of frames constituting the FRU can be defined as N_FRU, and the number of repetition of the FRU can be defined as NFRAM_TYPE.

The first signal frame structure corresponds to a single FFT frame structure where data symbols within one frame have the same OFDM symbol structure (FFT size, GI length, and pilot pattern).

FIG. 36 illustrates a signal frame structure according to one embodiment of the present invention.

FIG. 36 illustrates layers of a second signal frame according to an embodiment of the present invention.

The second signal frame structure corresponds to a mixed FFT frame structure where data symbols within one frame have multiple, different OFDM symbol structures (FFT size, GI length, and pilot pattern).

If sets having the same OFDM structure within a mixed FFT frame are defined as a partition, a mixed FFT frame can include multiple partitions. The FFT size, GI length, and pilot pattern can be configured independently for each partition; and location information and structure information of the corresponding partition may be transmitted from the preamble.

FIG. 37 illustrates a signal frame structure according to a yet another embodiment of the present invention.

FIG. 37 illustrates layers of a third signal frame according to an embodiment of the present invention.

The structure of the third signal frame is similar to that of the second signal frame of FIG. 36, but differs in that multiple frame types are transmitted as a single frame.

In other words, the frame type is one-to-one mapped to the partition of FIG. 36. In the case of the third signal frame structure, the bootstrap signal and the preamble can be transmitted at the start of the FRU one by one.

FIG. 38 illustrates a signal frame structure according to a still another embodiment of the present invention.

FIG. 38 illustrates layers of a fourth signal frame according to an embodiment of the present invention.

The structure of the fourth signal frame is the same as that of the third signal frame of FIG. 37. As the mixed FFT frame is defined, multiple frame types can be transmitted within one frame. Therefore, if a frame is defined as such a unit having a fixed TDM structure of frame type, it is not necessarily to define the structure of the super frame. Therefore, layers can be reconstructed so that the hierarchy can be formed in the order of frame, Sub-frame Repetition Unit (SRU), and subframe.

In this case, the frame can start with the bootstrap and preamble; and a data symbol area can include a plurality of subframes. A subframe can be configured by separate FFT size, GI length, and pilot pattern.

FIG. 39 illustrates a signal frame structure according to a further embodiment of the present invention.

FIG. 39 illustrates layers of a fifth signal frame according to an embodiment of the present invention.

The fifth signal frame structure exhibits a more flexible signal structure removing the repetition structure found in the fourth signal frame structure described above. The fifth signal frame structure has a more simplified layer hierarchy connecting a signal frame directly to a subframe. As shown in the fourth signal frame, a frame starts with the bootstrap and preamble; and the data symbol area includes a plurality of subframes. A subframe can be configured by separate FFT size, GI length, and pilot pattern.

Information about the FFT size, GI length, and pilot pattern of a subframe can be included in the preamble. For each subframe, TDM (Time Division Multiplexing)/LDM (Layered Division Multiplexing)/LTDM (Layered Time Division Multiplexing) configuration can be applied independently. And configuration information such as TDM/LDM/LTDM for the corresponding subframe can be included in the preamble.

For each subframe, a cell multiplexing method with respect to a PLP within the subframe (for example, TDM/FDM-like/TDFM-like, non-dispersed/dispersed, or TDM/sub-slicing/dispersed method) can be configured independently.

Information about a cell multiplexing method with respect to a PLP within the corresponding subframe can be included in the preamble.

For each subframe, a transmission method for SISO/MISO/MIMO system can be configured independently. The transmission method for SISO/MISO/MIMO system can be included in the preamble.

In the description above, inclusion of specific information in the preamble indicates that the specific information is included in the L1 signaling information/data transmitted through the preamble.

In what follows, it is assumed that a broadcast system transmits and received a signal according to the fifth signal frame structure of FIG. 39. Also, it can be further assumed that the edge symbol is called a subframe boundary symbol. In particular, in case the edge symbol is located at the starting symbol or at the last symbol of the subframes, the edge symbol can be called a subframe boundary symbol.

FIG. 40 illustrates a signal frame structure and an edge symbol structure according to one embodiment of the present invention.

The signal frame of FIG. 40 has the same signal frame structure as shown in FIG. 39. However, FIG. 40 illustrates an embodiment of a single FFT frame where symbols in a signal frame have the same/constant FFT size. In FIG. 40, a preamble symbol is denoted by P, a data symbol by D, a preamble symbol having the edge symbol structure by P/E, and a data symbol having the edge symbol structure by D/E.

In the signal frame of FIG. 40, the preamble symbol or the first data symbol can be an edge symbol. Also, the last data symbol in the signal frame of FIG. 40 can be an edge symbol. Since the signal frame of FIG. 40 uses the signal frame structure of FIG. 39, the first data symbol and the last data symbol of the signal frame can correspond to the first data symbol of the first subframe and the last data symbol of the last subframe, respectively.

In the embodiment of FIG. 40(a), the preamble symbol has the same FFT size as a following data symbol. In case the preamble has the same FFT size as the data symbol, time interpolation for channel estimation can be performed easily, and therefore, the preamble (P/E) can also perform the role of the edge symbol. In other words, in this case, it is not necessary to densely dispose additional pilots in the data symbol to perform channel estimation/sync tracking. The structure of the preamble edge symbol can be the first or the second edge symbol structure described above.

In the embodiment of FIG. 40(b), the preamble symbol has a different FFT size from that of a following data symbol. In this case, using only the preamble pilot inevitably leads to difficulty in time interpolation for channel estimation or performance degradation. Therefore, the data symbol which immediately follows the preamble can be the edge symbol. The structure of the edge symbol can be the first or the second edge symbol structure described above. Parameters required for decoding the edge symbol structure can be included in the preamble structure. This method can also be applied to a more general situation where the preamble has a different waveform structure other than the OFDM symbol.

The signaling information transmitted being included in the preamble or the bootstrap can include edge SP mode information (1 bit or 2 bit), edge CP mode information (1 bit), and so on. In the embodiment of FIG. 40(a), since preamble decoding can be performed only when the pilot structure of the preamble is known, the edge symbol structure information with respect to the preamble edge symbol should be included in the bootstrap. The edge symbol structure information about the data edge symbol can be included in the preamble. In the embodiment of FIG. 40(b), the edge symbol structure information about the data edge symbols can be included in the preamble.

FIG. 41 illustrates a signal frame structure and an edge symbol structure according to another embodiment of the present invention.

The signal frame of FIG. 41 has the same signal frame structure of FIG. 39. However, FIG. 41 illustrates an embodiment of a mixed FFT frame where symbols have different FFT sizes within the signal frame. In FIG. 41, a preamble symbol is denoted by P, a data symbol by D, a preamble symbol having the edge symbol structure by P/E, and a data symbol having the edge symbol structure by D/E.

In FIG. 41, a set of data symbols having the same FFT size can be called a partition/frame type/subframe, and this document refers to the set as a subframe. Since FFT sizes are different from each other, performance of channel estimation/sync tracking among subframes can be degraded. Therefore, as shown in FIG. 41, the first symbol and the last symbol of the subframes can be configured as edge symbols. The edge symbol can be called a subframe boundary symbol, as described above.

FIG. 41 illustrates the case where the first and the last symbol of each subframe are used as the edge symbol. However, as shown in FIG. 41(b), the first symbol of the first subframe rather than the preamble symbol may be used as the edge symbol.

To reduce system overhead, the edge symbol may be partly applied. For example, the edge symbol structure can be applied to only one of the preceding and following symbols of the subframe boundary. For example, in case the last symbol of the preceding subframe corresponds to an edge symbol, the first symbol of following consecutive subframes may not adopt the edge symbol structure. Also, in case the first symbol of the following subframe is edge symbol, the last symbol of the preceding subframe may not adopt the edge symbol structure. The location information of the edge symbol can be transmitted from the preamble. In other words, whether the first symbol and/or the last symbol of the subframe correspond to edge symbols or data symbols can be signaled through the edge symbol mode information described above.

In the signal frame of FIG. 41, the preamble symbol or the first data symbol can be an edge symbol. Also, the last data symbol in the signal frame of FIG. 41 can be an edge symbol. Since the signal frame of FIG. 41 uses the signal frame structure of FIG. 39, the first data symbol and the last data symbol of the signal frame can correspond to the first data symbol of the first subframe and the last data symbol of the last subframe, respectively.

In the embodiment of FIG. 41(a), the preamble symbol has the same FFT size as a following data symbol. In case the preamble has the same FFT size as the data symbol, time interpolation for channel estimation can be performed easily, and therefore, the preamble (P/E) can also perform the role of the edge symbol. In other words, in this case, it is not necessary to densely dispose additional pilots in the data symbol to perform channel estimation/sync tracking. The structure of the preamble edge symbol can be the first or the second edge symbol structure described above. In other words, the preamble symbol can include pilots on the basis of Dx units.

In the embodiment of FIG. 40(b), the preamble symbol has a different FFT size from that of a following data symbol. In this case, using only the preamble pilot inevitably leads to difficulty in time interpolation for channel estimation or performance degradation. Therefore, at least one data symbol which immediately follows the preamble can be the edge symbol. The structure of the edge symbol can be the first or the second edge symbol structure described above. Parameters required for decoding the edge symbol structure can be included in the preamble structure. This method can also be applied to a more general situation where the preamble has a different waveform structure other than the OFDM symbol.

The signaling information transmitted being included in the preamble or the bootstrap can include edge SP mode information (1 bit or 2 bit), edge CP mode information (1 bit), and so on. In the embodiment of FIG. 41(a), since preamble decoding can be performed only when the pilot structure of the preamble is known, the edge symbol structure information with respect to the preamble edge symbol should be included in the bootstrap. The edge symbol structure information about the data edge symbol can be included in the preamble. In the embodiment of FIG. 41(b), the edge symbol structure information about the data edge symbols can be included in the preamble. In FIG. 41, the edge symbol structure of the edge symbols may be signaled independently.

FIG. 42 illustrates a scattered pilot pattern according to one embodiment of the present invention.

FIG. 42 illustrates a pattern of a scattered pilot where a combination of Dx and Dy is inserted into a signal frame. In particular, FIG. 42 illustrates an embodiment where the Dx

basis value is used as 3 and 4 interchangeably. The Dx information of the SP of a data symbol can be known through FFT/GI information. The Dx basis information can be obtained without additional signaling only if the GI information is transmitted by the bootstrap.

As shown in FIG. 42, scattered pilot pattern information for a subframe can be signaled. In case the first edge symbol structure described with respect to the pilot of the edge symbol is used, the receiver can obtain scattered pilot pattern information of the corresponding subframe and process the pilot of the edge symbol by using the Dx value of the scattered pilot pattern.

FIG. 43 illustrates a method for transmitting a broadcast signal according to one embodiment of the present invention.

As described with respect to the broadcast signal transmitter and its operation, the broadcast signal transmitter can input process input data by using the input formatting module and output at least one Data Pipe (DP), namely, Physical Layer Pipe (PLP) data S43010. And the broadcast signal transmitter can error correction process or FEC encode the data included in at least one PLP by using the BICM module S43020. The broadcast signal transmitter can generate a signal frame which includes at least one PLP data by using the framing module S43030. And the broadcast signal transmitter can generate a transmitting signal by OFDM modulating the signal frame by using the waveform generating module S43040.

As described in FIGS. 31 to 41, the signal frame of a transmitting signal comprises a bootstrap, a preamble, and a data part.

A bootstrap comprises a plurality of symbols, and the FFT size can be fixed to be 2K. The bootstrap symbol can be used for signaling system bandwidth information (6, 7, 8 MHz) of a transmitting signal and information about a preamble structure.

A preamble comprises a plurality of symbols and is always disposed behind the bootstrap and before the first subframe. The FFT size for the preambles can be chosen from 8K, 16K, and 32K. The FFT size used can be the same as or different from the FFT size of the first subframe. The preamble contains L1 signaling information about the remainder of the frame.

One signal frame can comprise at least one subframe. And the FFT size for each subframe can be chosen from 8K, 16K, and 32K, and the FFT size for each subframe can be the same as or different from the FFT size of others. A subframe has a FFT size, GI length, scattered pilot pattern, and Number of useful Carriers (NoC) which are fixed with respect to the corresponding subframe. And the FFT size information, GI length information, scattered pilot pattern information, and NoC information of the corresponding subframe can be transmitted or received being included in the preamble.

As described with reference to FIGS. 31 to 41, at least one of the first and the last symbol of at least one subframe can be used as a subframe boundary symbol. The subframe boundary symbol has a higher scattered pilot density than that of data symbols of the subframe. The scattered pilots of the subframe boundary symbol are determined based on scattered pilot density (Dx) of data symbols of the subframe, and the pilot density (Dx) indicates separation of pilot bearing carriers in frequency direction. In other words, the carrier separation of pilots of the subframe boundary symbol can be determined by the Dx value. For example, if Dx is 3, those cells carrier indices of which are a multiple of 3 can be subframe boundary pilots.

As described with reference to FIGS. 31 to 41, at least one of the first and the last symbol of subframes of a frame can be used as a subframe boundary symbol. In case a signal frame comprises a plurality of subframes, at least one of the last symbol of a preceding subframe and the first symbol of a following subframe located at the boundary of the subframes can be used as the subframe boundary symbol. The first symbol of the first subframe following the preamble of a signal frame can be used as the subframe boundary symbol according to whether the preamble and the first subframe have the same FFT size.

As described above, the first symbol and the last symbol of a subframe can selectively become the subframe boundary symbol. For example, the first symbol of the first subframe, the last symbol at the boundary of subframes, and the last symbol at the boundary of subframes can optionally become as the subframe boundary symbol. Therefore, the subframe boundary mode information indicating presence of the subframe boundary symbol can be transmitted through the preamble. The subframe boundary mode information may indicate whether the first and the last symbol of each subframe is subframe boundary symbol.

FIG. 44 illustrates a method for receiving a broadcast signal according to one embodiment of the present invention.

As described with respect to the broadcast signal receiver and its operation, the broadcast signal receiver can OFDM demodulate a received broadcast signal by using the synchronization & demodulation module S44010. The broadcast signal receiver can parse a signal frame of a broadcast signal by using the frame parsing module S44020. The broadcast signal receiver may extract and decode preamble data included in a signal frame and extract a desired subframe or PLP data by using the L1 signaling information obtained from the preamble data. The broadcast signal receiver can convert the PLP data extracted from a broadcast signal into the bit domain by using the demapping and decoding module and FEC decode the converted PLP data into a data stream by using the output processing module S44030. And the broadcast signal can output the PLP data into a data stream by using the output processing module S44040.

The synchronization and demodulation module of the broadcast signal receiver may perform channel estimation and sync tracking by using the pilots included in a received signal. In particular, the broadcast signal receiver according to the present invention may perform channel estimation and sync tracking of the corresponding subframe or a neighboring subframe by using the subframe boundary symbol.

As described with reference to FIGS. 31 to 41, the signal frame of a received signal comprises a bootstrap, a preamble, and a data part.

A bootstrap comprises a plurality of symbols, and the FFT size can be fixed to be 2K. The bootstrap symbol can be used for signaling system bandwidth information (6, 7, 8 MHz) of a received signal and information about a preamble structure.

A preamble comprises a plurality of symbols and is always disposed behind the bootstrap and before the first subframe. The FFT size for the preambles can be chosen from 8K, 16K, and 32K. The FFT size used can be the same as or different from the FFT size of the first subframe. The preamble contains L1 signaling information about the remainder of the frame.

One signal frame can comprise at least one subframe. And the FFT size for each subframe can be chosen from 8K, 16K, and 32K, and the FFT size for each subframe can be the same as or different from the FFT size of others. A subframe

has a FFT size, GI length, scattered pilot pattern, and Number of useful Carriers (NoC) which are fixed/constant with respect to the corresponding subframe. And the FFT size information, GI length information, scattered pilot pattern information, and NoC information of the corresponding subframe can be transmitted or received being included in the preamble.

The receiver can decode the preamble by using the signaling information contained in the bootstrap; and decode a subframe and the PLP data contained in the subframe by using the signaling information included in the preamble.

As described with reference to FIGS. 31 to 41, at least one of the first and the last symbol of at least one subframe can be used as a subframe boundary symbol. The subframe boundary symbol has a higher scattered pilot density than that of data symbols of the subframe. The scattered pilots of the subframe boundary symbol are determined based on scattered pilot density (Dx) of data symbols of the subframe, and the pilot density (Dx) indicates separation of pilot bearing carriers in frequency direction. In other words, the carrier separation of pilots of the subframe boundary symbol can be determined by the Dx value. For example, if Dx is 3, those cells carrier indices of which are a multiple of 3 can be subframe boundary pilots.

As described with reference to FIGS. 31 to 41, at least one of the first and the last symbol of subframes of a frame can be used as a subframe boundary symbol. In case a signal frame comprises a plurality of subframes, at least one of the last symbol of a preceding subframe and the first symbol of a following subframe located at the boundary of the subframes can be used as the subframe boundary symbol. The first symbol of the first subframe following the preamble of a signal frame can be used as the subframe boundary symbol according to whether the preamble and the first subframe have the same FFT size.

As described above, the first symbol and the last symbol of a subframe can be used selectively as the subframe boundary symbol. For example, the first symbol of the first subframe, the last symbol at the boundary of subframes, and the last symbol at the boundary of subframes can be used optionally as the subframe boundary symbol. Therefore, the subframe boundary mode information indicating presence of the subframe boundary symbol can be transmitted through the preamble. The subframe boundary mode information may indicate whether the first and the last symbol of each subframe is subframe boundary symbol.

According to the present invention, a signal frame comprises at least one subframe which has the same/constant FFT size, GI length, and pilot pattern, thereby ensuring transmission and reception efficiency and flexibility while minimizing signaling information. However, since FFT sizes are different from each other among subframes, pilot pattern can be changes according to the different FFT size. Therefore, performance of channel estimation and sync tracking among subframes can be degraded.

By disposing a subframe boundary symbol having a higher pilot density selectively at the boundary of subframes, the present invention can minimize degradation of performance of channel estimation and sync tracking due to an abrupt change of the signal structure. And by selectively disposing the subframe boundary symbol and signaling presence of the subframe boundary symbol, the present invention can minimize pilot overhead and operate the system in a flexible manner.

In particular, by selectively using the subframe boundary symbol structure for neighboring subframes and the subframes adjacent to the preamble according to whether FFT

sizes are the same with each other, the present invention can compromise system performance for reduced pilot overhead.

In the specification, methods and apparatuses for receiving and transmitting a broadcast signal are used.

It will be appreciated by those skilled in the art that various modifications and variations can be made in the present invention without departing from the spirit or scope of the inventions. Thus, it is intended that the present invention covers the modifications and variations of this invention provided they come within the scope of the appended claims and their equivalents.

Both apparatus and method inventions are mentioned in this specification and descriptions of both of the apparatus and method inventions may be complementarily applicable to each other.

What is claimed is:

1. A broadcast signal receiver, comprising:
 - a demodulator configured to demodulate a received broadcast signal;
 - a de-framer configured to de-frame a signal frame of the broadcast signal;
 - a time de-interleaver configured to time de-interleave Physical Layer Pipe, PLP, data of the signal frame,
 - a de-mapper configured to de-map the time de-interleaved PLP data;
 - a decoder configured to decode the de-mapped PLP data; and
 - wherein the signal frame comprises a preamble and a plurality of subframes,
 - wherein a foremost symbol of a first subframe is configured as a first edge symbol when the first subframe is immediately preceded by a second subframe and Fast Fourier Transform (FFT) sizes of the first subframe and the second subframe are different from each other,
 - wherein a last symbol of the first subframe is configured as a second edge symbol when the first subframe is immediately followed by a third subframe and FFT sizes of the first subframe and the third subframe are different from each other,
 - wherein an edge symbol comprises pilots which are scattered and continual pilots (CPs) and the pilots scattered in the edge symbol are denser than pilots scattered in data symbols of a same subframe, and
 - wherein the preamble comprises information for indicating whether each of the foremost symbol or the last symbol is the edge symbol or not.
2. The broadcast signal receiver of claim 1, wherein a last symbol of a last subframe of the signal frame is a subframe boundary symbol.
3. The broadcast signal receiver of claim 1, wherein carrier separation of the pilots scattered in the edge symbol

is determined as Dx of a pattern for pilots scattered the data symbols of the subframe, the pattern is defined by the Dx and Dy, the Dx being separation of pilot bearing carriers in a frequency direction and Dy being number of symbols forming one scattered pilot sequence in time direction.

4. The broadcast signal receiver of claim 1, wherein each of the subframe has a fixed FFT size, fixed GI length and a fixed pilot pattern respectively, and the preamble comprises FFT size information, GI information and pilot pattern information for the each subframe.

5. A method of receiving a broadcast signal, comprising: demodulating a received broadcast signal; de-framing a signal frame of the broadcast signal; time de-interleaving Physical Layer Pipe, PLP, data of the signal frame, de-mapping the time de-interleaved PLP data; decoding the de-mapped PLP data; and wherein the signal frame comprises a preamble and a plurality of subframes, wherein a foremost symbol of a first subframe is configured as a first edge symbol when the first subframe is immediately preceded by a second subframe and Fast Fourier Transform (FFT) sizes of the first subframe and the second subframe are different from each other, wherein a last symbol of the first subframe is configured as a second edge symbol when the first subframe is immediately followed by a third subframe and FFT sizes of the first subframe and the third subframe are different from each other, wherein an edge symbol comprises pilots which are scattered and continual pilots (CPs) and the pilots scattered in the edge symbol are denser than for pilots scattered in data symbols of a same subframe, and wherein the preamble comprises information for indicating whether each of the foremost symbol or the last symbol is the edge symbol or not.

6. The method of claim 5, wherein a last symbol of a last subframe of the signal frame is a subframe boundary symbol.

7. The method of claim 5, wherein carrier separation of the pilots scattered in the edge symbol is determined as Dx of a pattern for pilots scattered in the data symbols of the subframe, the pattern is defined by the Dx and Dy, the Dx being separation of pilot bearing carriers in a frequency direction and Dy being number of symbols forming one scattered pilot sequence in time direction.

8. The method of claim 5, wherein each of the subframe has a fixed FFT size, fixed GI length and a fixed pilot pattern respectively, and the preamble comprises FFT size information, GI information and pilot pattern information for the each subframe.

* * * * *