

US010493562B2

(12) **United States Patent**  
**Dimter et al.**

(10) **Patent No.:** **US 10,493,562 B2**  
(45) **Date of Patent:** **Dec. 3, 2019**

(54) **SELECTIVE LASER SOLIDIFICATION APPARATUS AND METHOD**

(71) Applicant: **RENISHAW PLC**, Gloucestershire (GB)

(72) Inventors: **Marc Frank Dimter**, Kornwestheim (DE); **Ralph Markus Mayer**, Kornwestheim (DE); **Thomas Hess**, Munich (DE)

(73) Assignee: **RENISHAW PLC**, Wotton-under-Edge (GB)

(\*) Notice: Subject to any disclaimer, the term of this patent is extended or adjusted under 35 U.S.C. 154(b) by 732 days.

(21) Appl. No.: **14/766,627**

(22) PCT Filed: **Feb. 13, 2014**

(86) PCT No.: **PCT/GB2014/050417**

§ 371 (c)(1),  
(2) Date: **Aug. 7, 2015**

(87) PCT Pub. No.: **WO2014/125280**

PCT Pub. Date: **Aug. 21, 2014**

(65) **Prior Publication Data**

US 2016/0001401 A1 Jan. 7, 2016

**Related U.S. Application Data**

(60) Provisional application No. 61/774,215, filed on Mar. 7, 2013.

(30) **Foreign Application Priority Data**

Feb. 14, 2013 (GB) ..... 1302602.6  
Mar. 5, 2013 (GB) ..... 1303920.1

(51) **Int. Cl.**  
**B23K 26/142** (2014.01)  
**B23K 26/342** (2014.01)  
(Continued)

(52) **U.S. Cl.**  
CPC ..... **B23K 26/142** (2015.10); **B22F 3/1055** (2013.01); **B23K 26/0869** (2013.01);  
(Continued)

(58) **Field of Classification Search**  
CPC . B22F 3/1055; B23K 26/0869; B23K 26/142; B23K 26/342; B33Y 30/00; B33Y 50/02; B29C 64/153; B29C 64/386  
See application file for complete search history.

(56) **References Cited**

**U.S. PATENT DOCUMENTS**

5,017,317 A 5/1991 Marcus  
5,155,324 A 10/1992 Deckard et al.  
(Continued)

**FOREIGN PATENT DOCUMENTS**

CN 101321600 A 12/2008  
CN 101842222 A 9/2010  
(Continued)

**OTHER PUBLICATIONS**

Ferrar et al., "Gas Flow Effects on selective laser melting (SLM) manufacturing performance", Oct. 2011, Elsevier, Journal of Materials Processing Technology, vol. 212, pp. 355-364.\*  
(Continued)

*Primary Examiner* — Geoffrey S Evans  
(74) *Attorney, Agent, or Firm* — Oliff PLC

(57) **ABSTRACT**

Selective laser solidification apparatus is described that includes a powder bed onto which a powder layer can be deposited and a gas flow unit for passing a flow of gas over the powder bed along a predefined gas flow direction. A laser scanning unit is provided for scanning a laser beam over the powder layer to selectively solidify at least part of the powder layer to form a required pattern. The required pattern is formed from a plurality of stripes or stripe segments that are formed by advancing the laser beam along the stripe or  
(Continued)

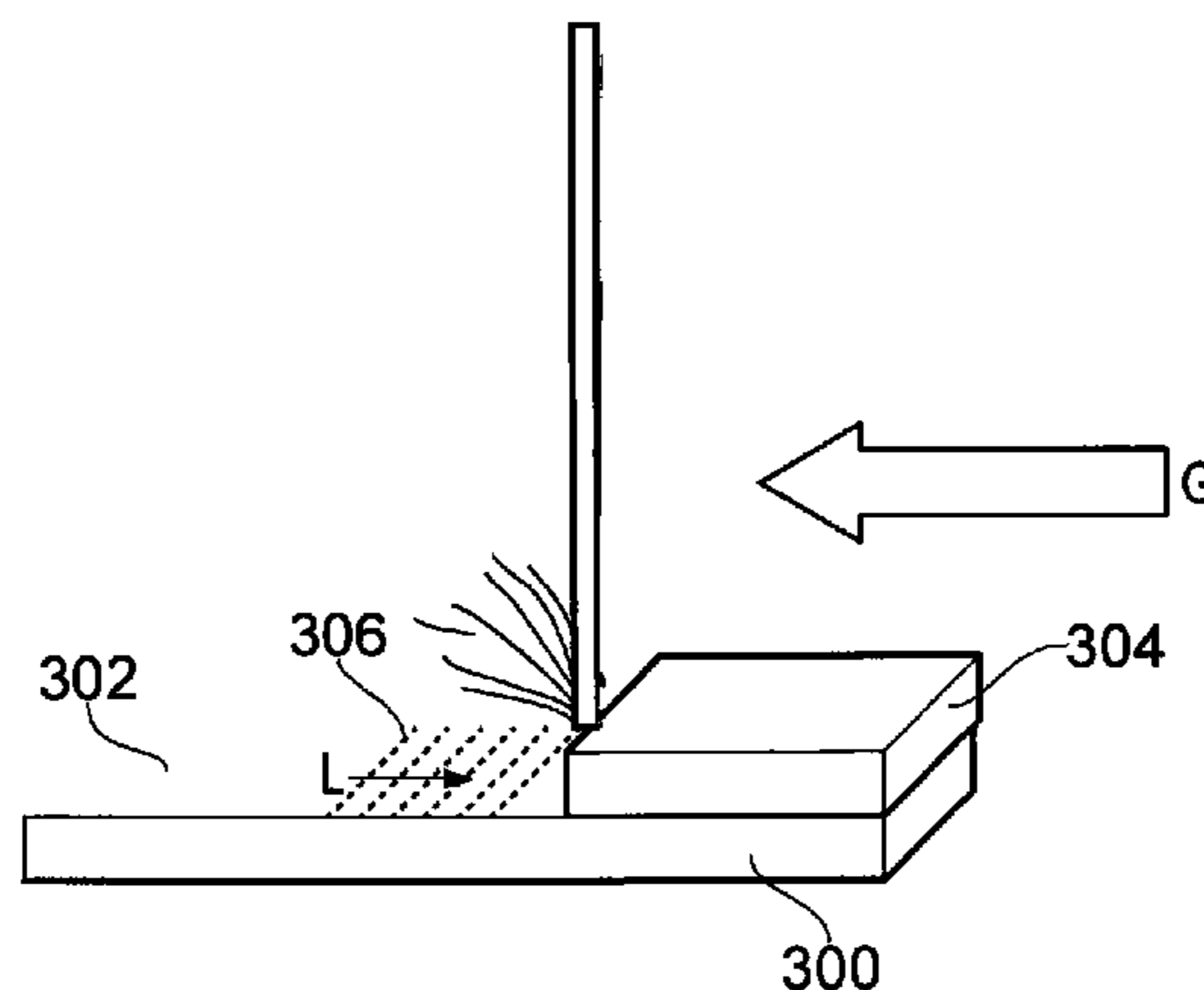

stripe segment in a stripe formation direction. The stripe formation direction is arranged so that it always at least partially opposes the predefined gas flow direction. A corresponding method is also described.

**11 Claims, 8 Drawing Sheets**

(51) **Int. Cl.**

**B33Y 50/02** (2015.01)  
**B22F 3/105** (2006.01)  
**B23K 26/08** (2014.01)  
**B29C 64/153** (2017.01)  
**B29C 64/386** (2017.01)  
**B33Y 30/00** (2015.01)  
**B33Y 10/00** (2015.01)  
**B28B 1/00** (2006.01)

(52) **U.S. Cl.**

CPC ..... **B23K 26/342** (2015.10); **B29C 64/153** (2017.08); **B29C 64/386** (2017.08); **B33Y 10/00** (2014.12); **B33Y 30/00** (2014.12); **B33Y 50/02** (2014.12); **B22F 2003/1056** (2013.01); **B22F 2999/00** (2013.01); **B28B 1/001** (2013.01); **Y02P 10/295** (2015.11)

(56)

**References Cited**

U.S. PATENT DOCUMENTS

5,352,405	A	10/1994	Beaman et al.	
5,534,104	A	7/1996	Langer et al.	
5,730,925	A	3/1998	Mattes et al.	
6,215,093	B1 *	4/2001	Meiners .....	B22F 3/1055 219/121.61
6,583,379	B1	6/2003	Meiners et al.	
6,694,207	B2	2/2004	Darrah et al.	
7,047,098	B2	5/2006	Lindemann et al.	
8,034,279	B2 *	10/2011	Dimter .....	B22F 3/1055 264/113
9,522,426	B2 *	12/2016	Das .....	B22F 3/1055
10,252,333	B2 *	4/2019	McMurtry .....	B22F 3/1055
2002/0015654	A1	2/2002	Das et al.	
2004/0099996	A1	5/2004	Herzog	
2005/0116391	A1	6/2005	Lindemann et al.	
2005/0142024	A1	6/2005	Herzog	
2006/0192322	A1	8/2006	Abe et al.	
2008/0241392	A1	10/2008	Dimter et al.	
2009/0017220	A1	1/2009	Muller et al.	
2009/0266803	A1	10/2009	Perret et al.	
2009/0291308	A1	11/2009	Pfister et al.	
2011/0135840	A1 *	6/2011	Doye .....	B22F 3/1055 427/554
2011/0221099	A1 *	9/2011	Oberhofer .....	B22F 3/1055 264/401
2011/0285060	A1	11/2011	Yamamoto et al.	
2012/0061360	A1 *	3/2012	Idaka .....	B23K 26/082 219/121.83
2012/0251378	A1 *	10/2012	Abe .....	B29C 67/0077 419/55
2016/0114432	A1	4/2016	Ferrar et al.	
2016/0114531	A1 *	4/2016	Chuang .....	B29C 67/0077 264/497
2016/0279706	A1 *	9/2016	Domrose .....	B22F 3/1055
2016/0288209	A1 *	10/2016	Jakimov .....	B22F 3/1055
2018/0185961	A1 *	7/2018	Meidani .....	B29C 64/386
2019/0077077	A1 *	3/2019	Martin .....	B22F 3/1055

FOREIGN PATENT DOCUMENTS

CN	101932429	A	12/2010
CN	102574333	A	7/2012

CN	102574333	B	7/2015
CN	105500720	A	4/2016
DE	19514740	C1	4/1996
DE	19649865	C1	2/1998
DE	19853947	C1	2/2000
DE	101 12 591	A1	10/2001
DE	100 42 132	A1	3/2002
DE	100 42 134	A1	3/2002
DE	102 08 150	A1	9/2002
DE	10 2004 031881	A1	1/2006
DE	10 2004 041 633	A1	3/2006
DE	10 2004 057 866	A1	6/2006
DE	10 2006 014835	A1	10/2007
DE	102004031881	B4 *	11/2007
DE	10 2006 059 851	A1	7/2008
DE	102007014683	A1	10/2008
DE	10 2010 052206		5/2012
EP	0 416 852	A2	3/1991
EP	0429196	A2	5/1991
EP	0590956	A1	4/1994
EP	0 617 657	B1	2/1997
EP	1234625	A1	8/2002
EP	1419836	A1	5/2004
EP	1839781	A2	10/2007
EP	1 583 626	B1	7/2010
EP	2431113	A1	3/2012
EP	2492084	A1	8/2012
EP	2978589	A1	2/2016
GB	2 046 801	A	11/1980
GB	2378151	A	2/2003
JP	62-151091	U *	9/1987
JP	2001-504897	A	4/2001
JP	2002-224864	A	8/2002
JP	2006-124732	A	5/2006
WO	88/02677	A2	4/1988
WO	92/08567	A1	5/1992
WO	92/08592	A1	5/1992
WO	WO-92/08592	A1 *	5/1992
WO	93/08928	A1	5/1993
WO	94/07681	A1	4/1994
WO	88/02677	A2	4/1998
WO	98/24574	A1	6/1998
WO	00/30785	A1	6/2000
WO	00/30789	A1	6/2000
WO	03/039844	A1	5/2003
WO	2006/024373	A2	3/2006
WO	2008/116518	A1	10/2008
WO	2009/156316	A1	12/2009
WO	2010/007396	A1	1/2010
WO	2011/049143	A1	4/2011
WO	2014/125258	A2	8/2014
WO	2014/125280	A2	8/2014
WO	2014125281	A2	8/2014
WO	2014/154878	A1	10/2014
WO	WO-2014/154879	A1 *	10/2014
WO	2014/199150	A1	12/2014

OTHER PUBLICATIONS

machine translation of German Patent document DE102004031881, Feb. 2018.\*  
 U.S. Appl. No. 14/179,021, filed Feb. 12, 2014 in the name of Ferrar.  
 Oct. 8, 2015 International Preliminary Report on Patentability and Written Opinion issued in PCT/EP2014/056323.  
 Jan. 17, 2017 Notice of Allowance issued in U.S. Appl. No. 14/179,021.  
 Jan. 25, 2017 Office Action issued in Chinese Application No. 201480020930.1.  
 Aug. 1, 2017 Office Action issued in Chinese Application No. 201480020930.1.  
 Apr. 10, 2017 Office Action issued in Chinese Patent Application No. 201480020782.3.  
 Oct. 9, 2014 Written Opinion issued in International Patent Application No. PCT/GB2014/050418.  
 Oct. 9, 2014 International Search Report issued in International Patent Application No. PCT/GB2014/050418.

(56)

**References Cited**

OTHER PUBLICATIONS

Aug. 28, 2014 International Search Report issued in International Patent Application No. PCT/GB2014/050417.

Aug. 28, 2014 Written Opinion issued in International Patent Application No. PCT/GB2014/050417.

Apr. 8, 2013 Search Report issued in British Patent Application No. 1303920.1.

Ferrar et al; "Gas flow effects on selective laser melting (SLM) manufacturing performance;" Journal of Materials Processing Technology, Elsevier, NL; Sep. 26, 2011; vol. 212; No. 2; pp. 355-364.

Abe et al; "Influence of forming conditions on the titanium model in rapid prototyping with the selective laser melting process;" Proceedings of the Institution of Mechanical Engineers, Part C, Journal of Mechanical Engineering Science; Mechanical Engineering Publications; Jan. 1, 2003; vol. 217; No. 1; pp. 119-126.

S. Dadbakhsh et al, "Effect of selective laser melting layout on the quality of stainless steel parts", Rapid Prototyping Journal, vol. 18, Issue 3, pp. 241-249.

Aug. 26, 2016 Office Action Issued in U.S. Appl. No. 14/179,021.

Jun. 14, 2016 Office Action issued in Chinese Patent Application No. 201480020782.3.

May 27, 2016 Office Action issued in Chinese Patent Application No. 201480020930.1.

EOS launches EOSINT M280 metal additive manufacturing system, Industrial Lasers.com website, Mar. 12, 2010.

Mar. 20, 2018 Office Action issued in Japanese Application No. 2015-557513.

Apr. 24, 2018 Search Report issued in European Application No. 17 20 9698.

Laser sintering system EOSINT M 280, "M-Solutions", Jun. 1, 2013, XP055134972.

Mar. 13, 2018 Office Action issued in Japanese Application No. 2015-557511.

EOSINT M 280/PSW 3.5, EOS GmbH—Electro Optical Systems, 2011, pp. 1-179.

English-language translation of JP-A-2002-224864.

Aug. 29, 2018 Office Action issued in U.S. Appl. No. 14/777,926.

Jul. 9, 2018 Search Report issued in European Patent Application No. 18161266.4.

May 31, 2019 Office Action issued in U.S. Appl. No. 15/461,743.

"Technical Description EOSINT M 280." EOS GmbH-Electro Optical Systems, pp. 1-33, 2010.

\* cited by examiner

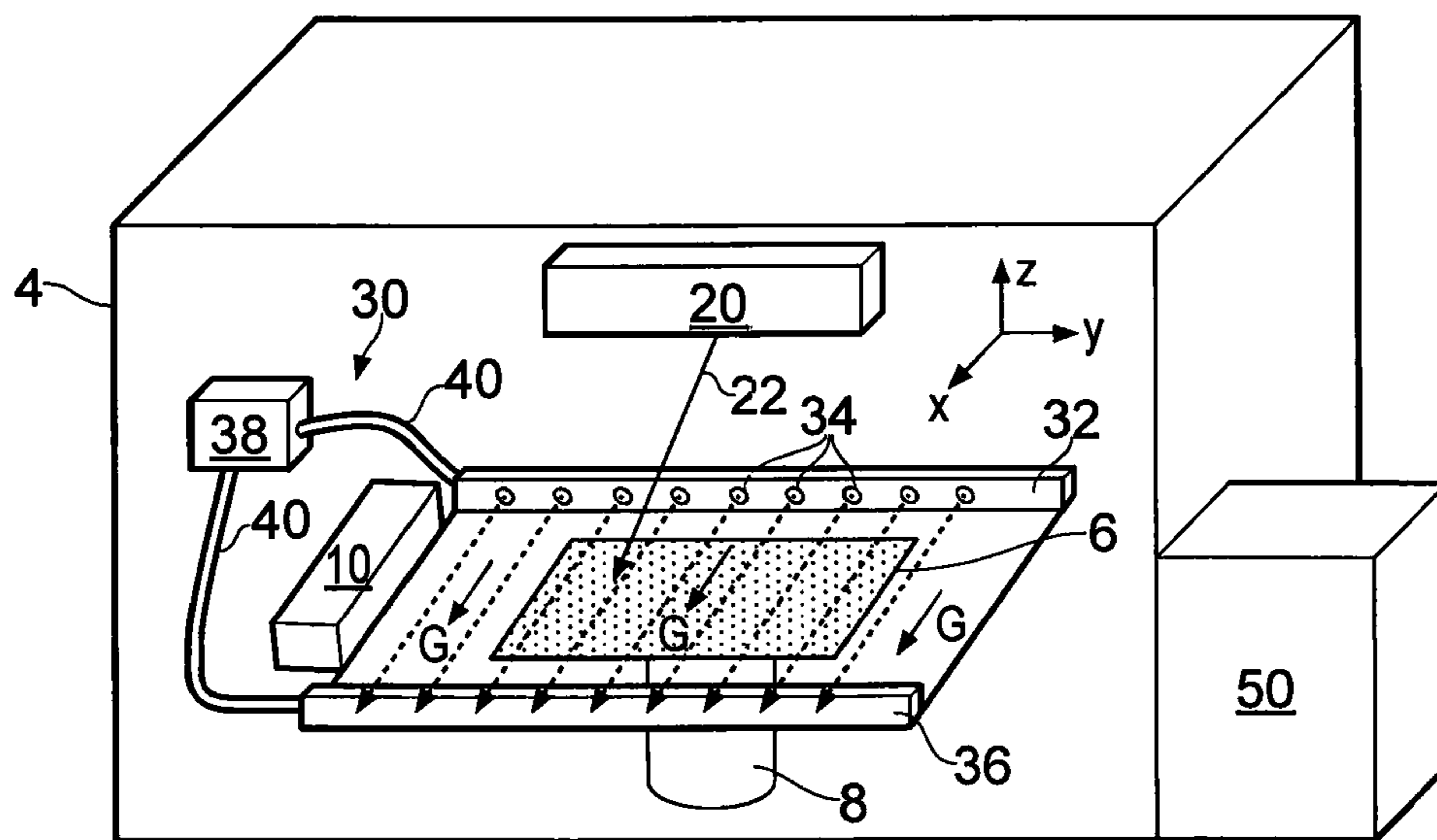

2 ↗

FIG. 1

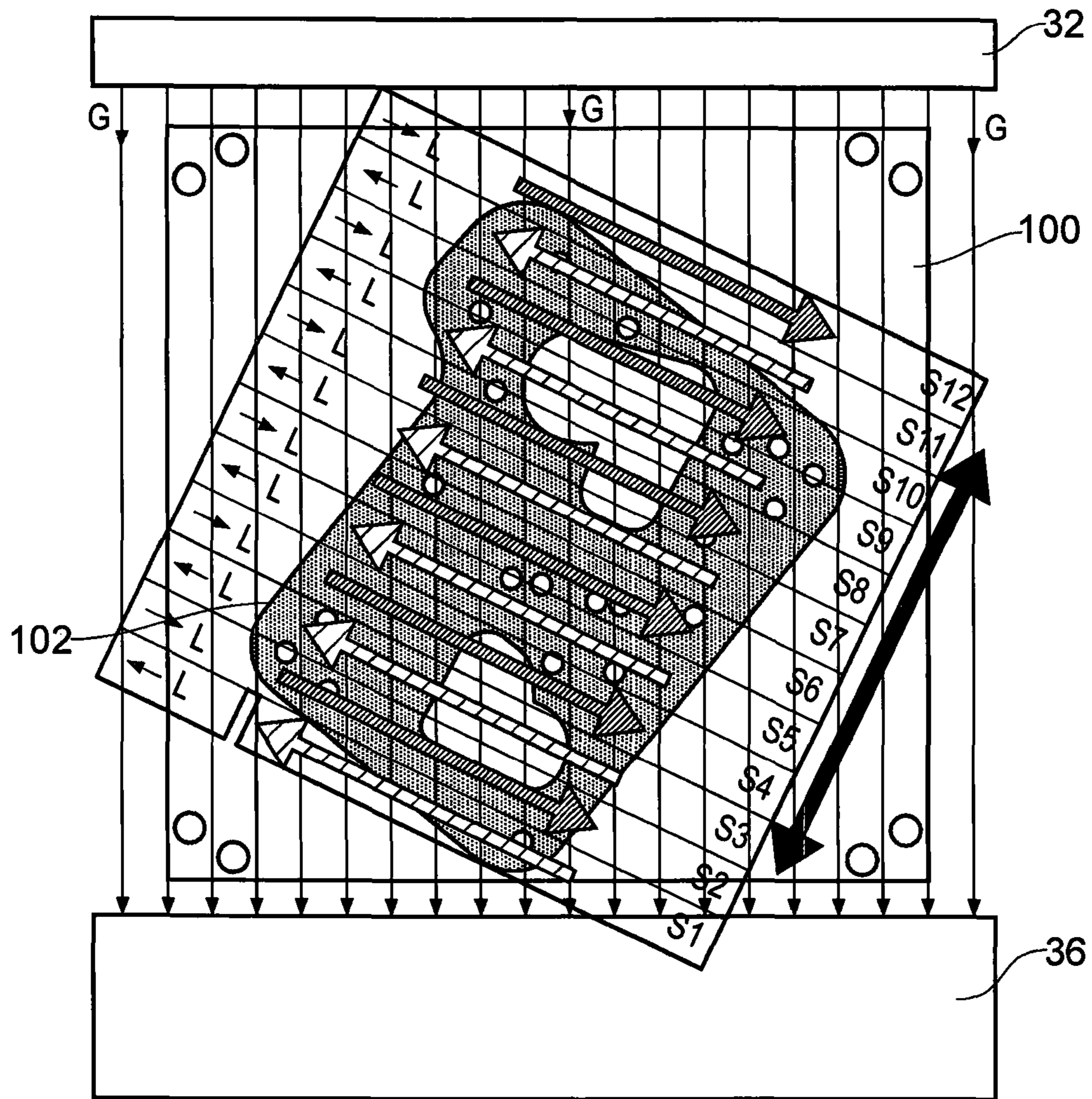

FIG. 2 (Prior Art)

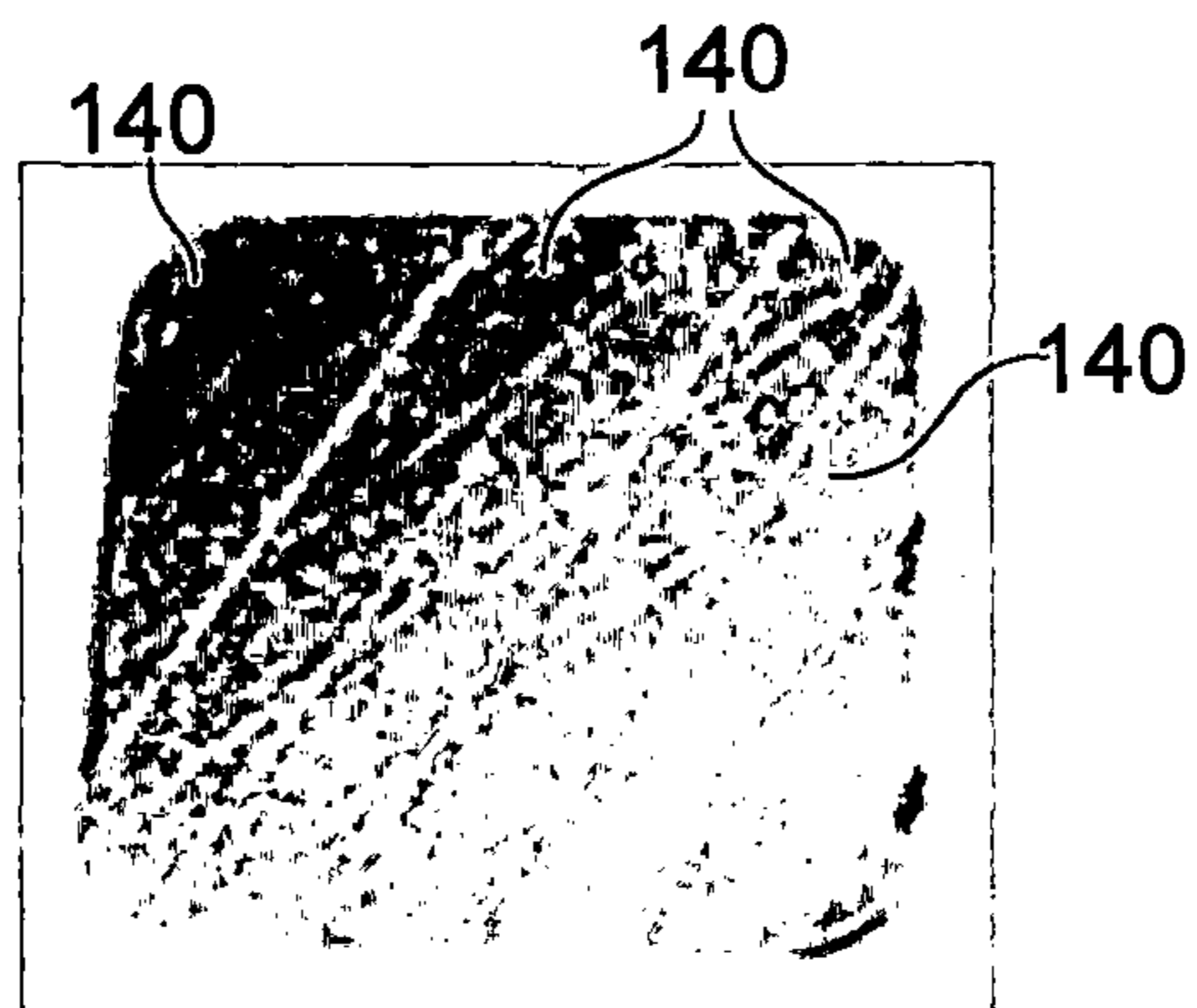

FIG. 3 (Prior Art)

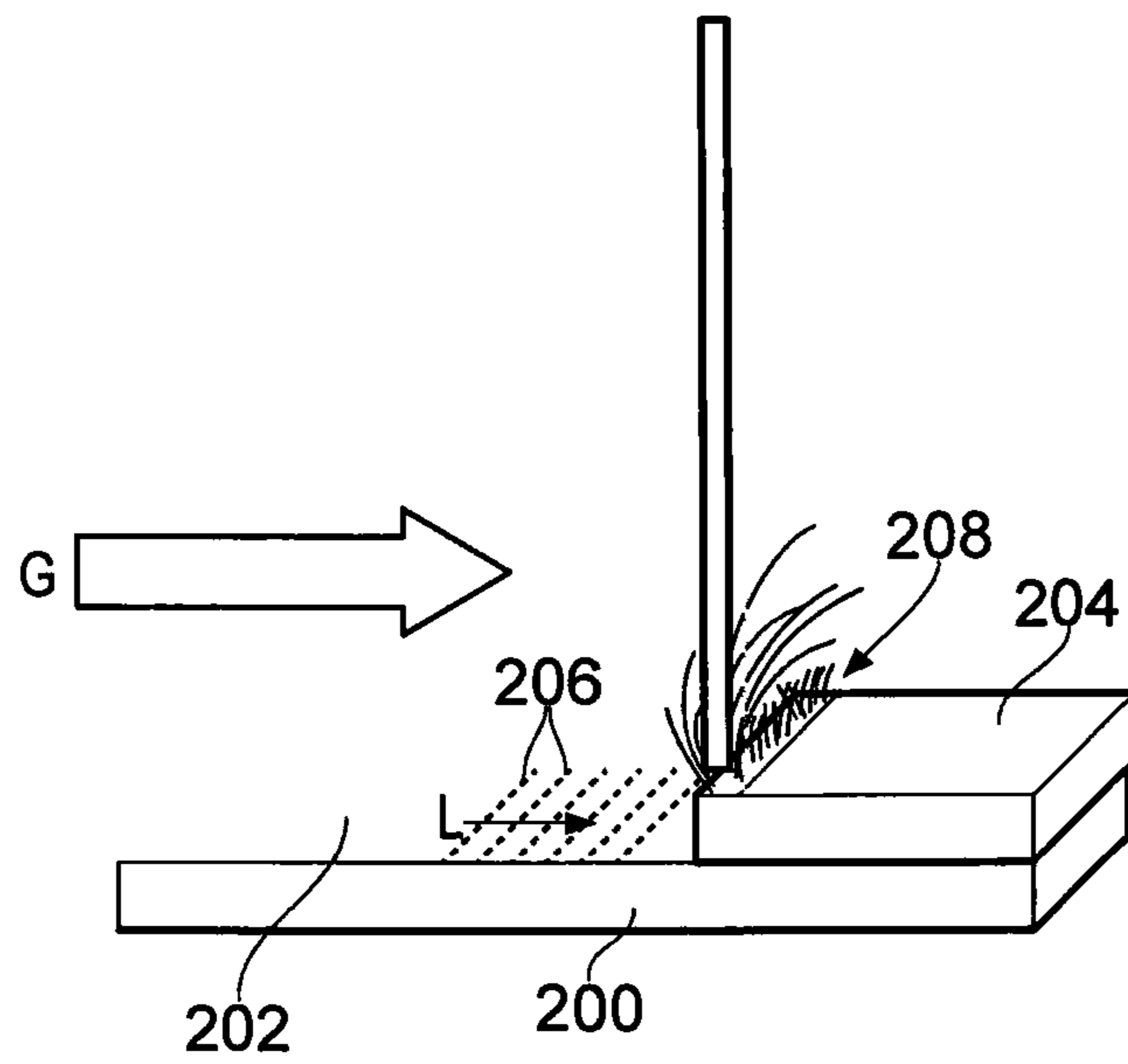

FIG. 4

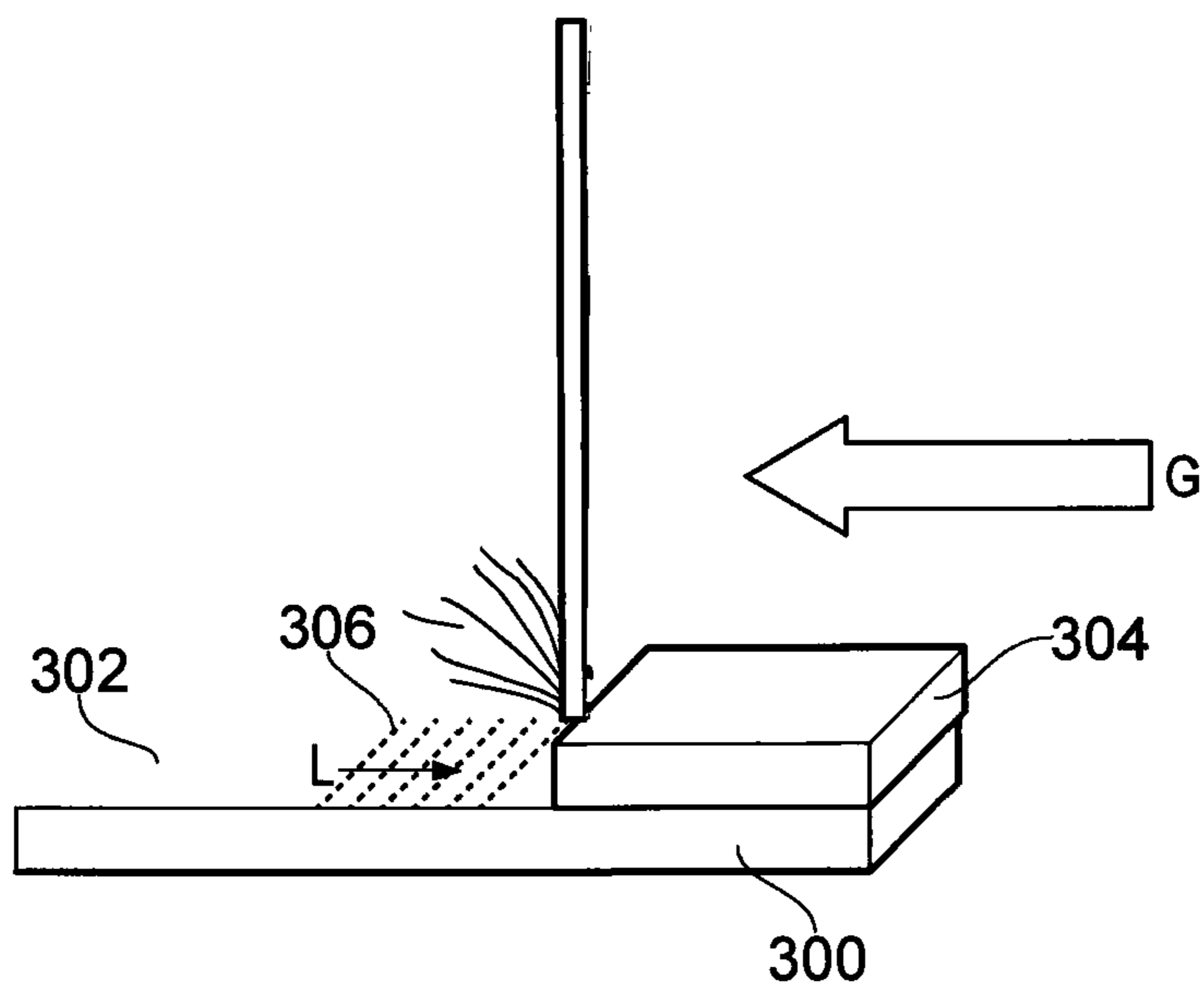

FIG. 5

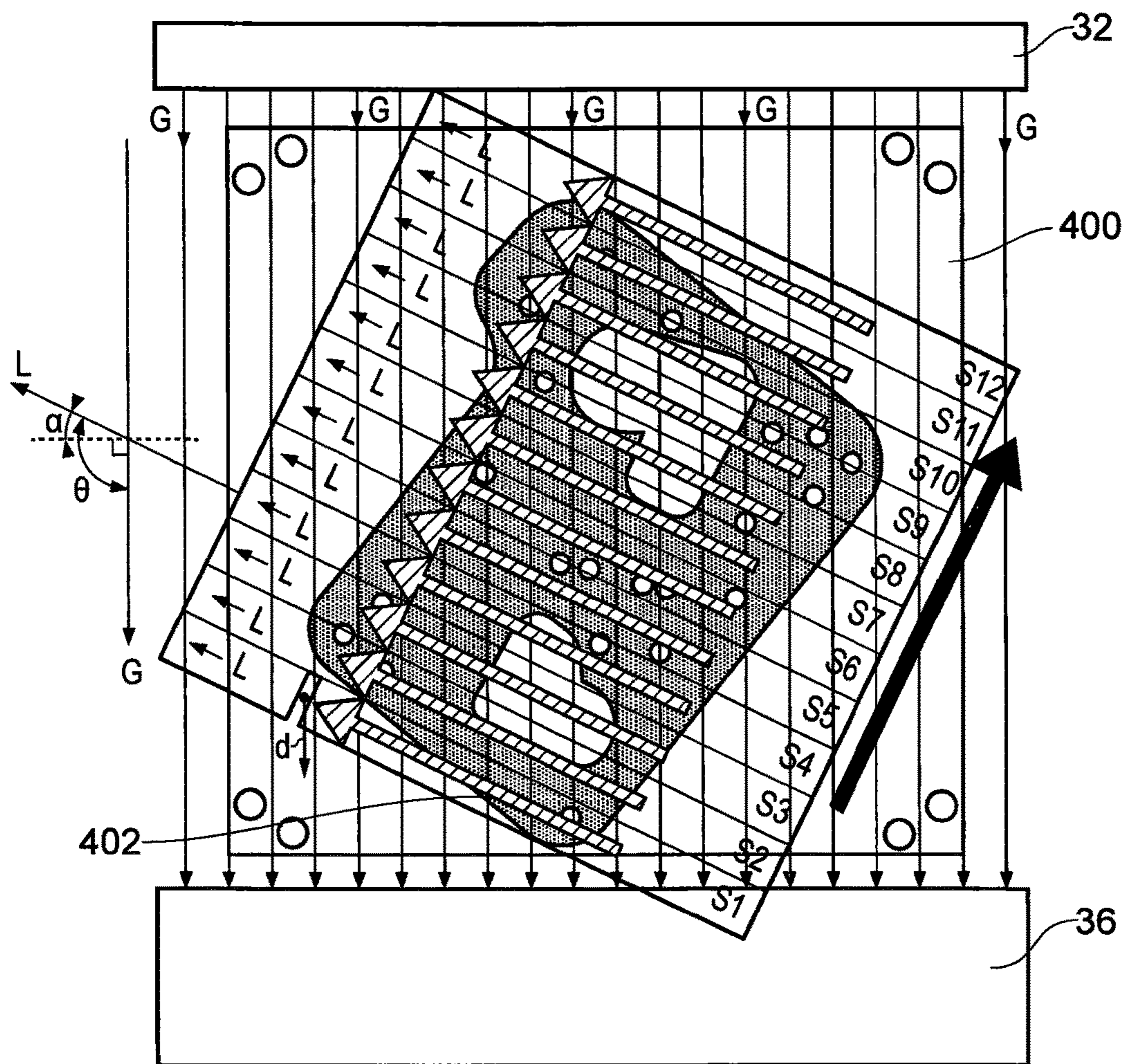

FIG. 6

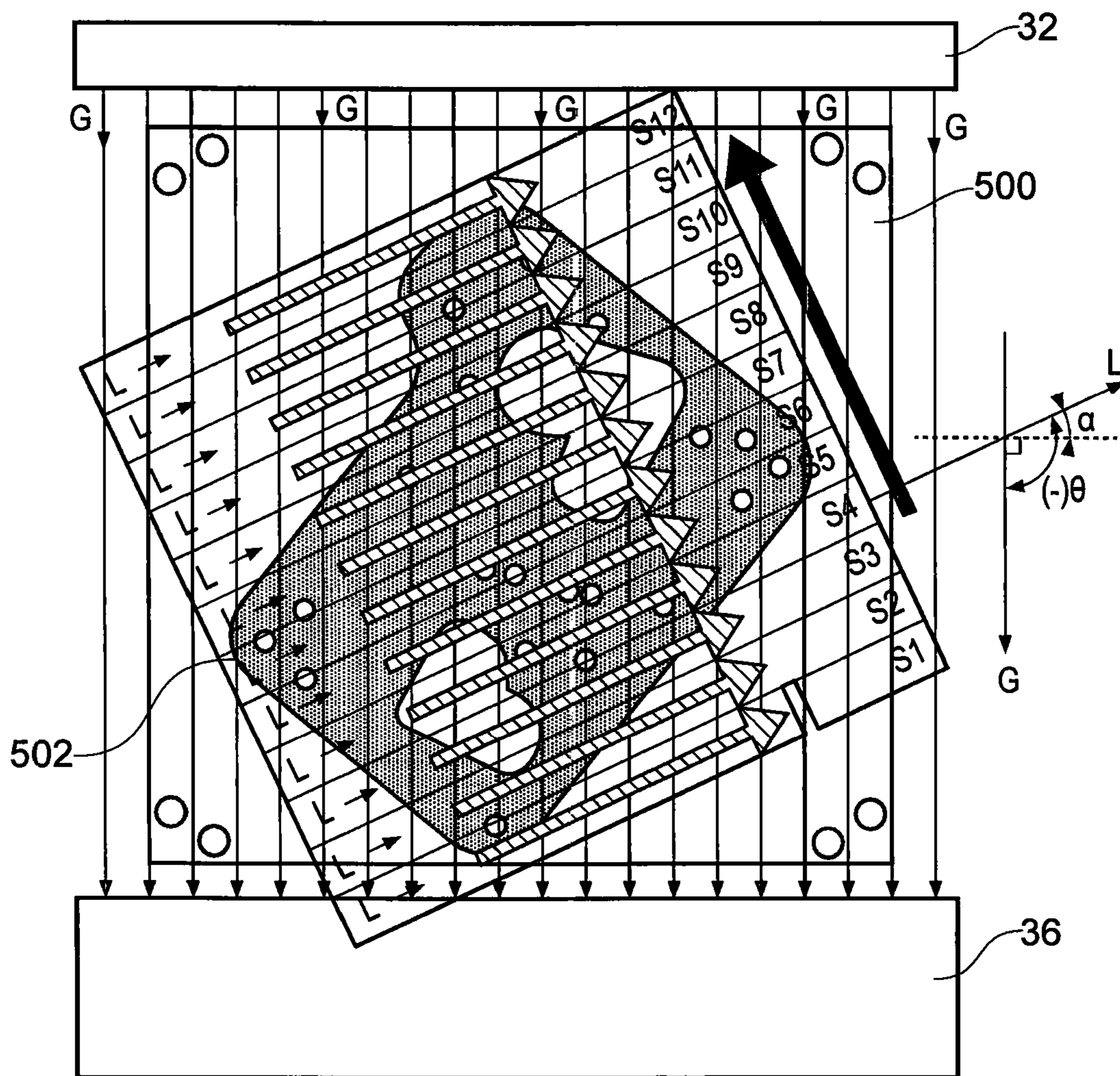

FIG. 7



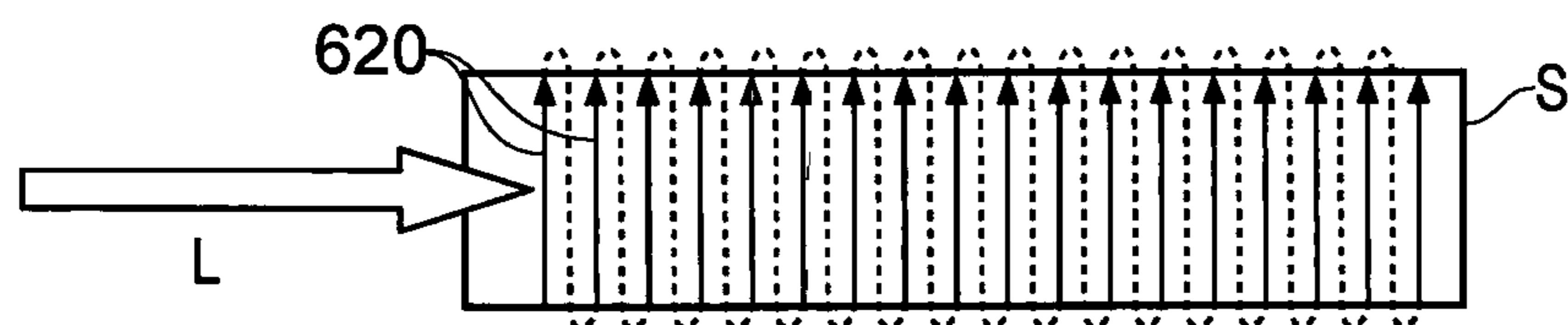

FIG. 8C

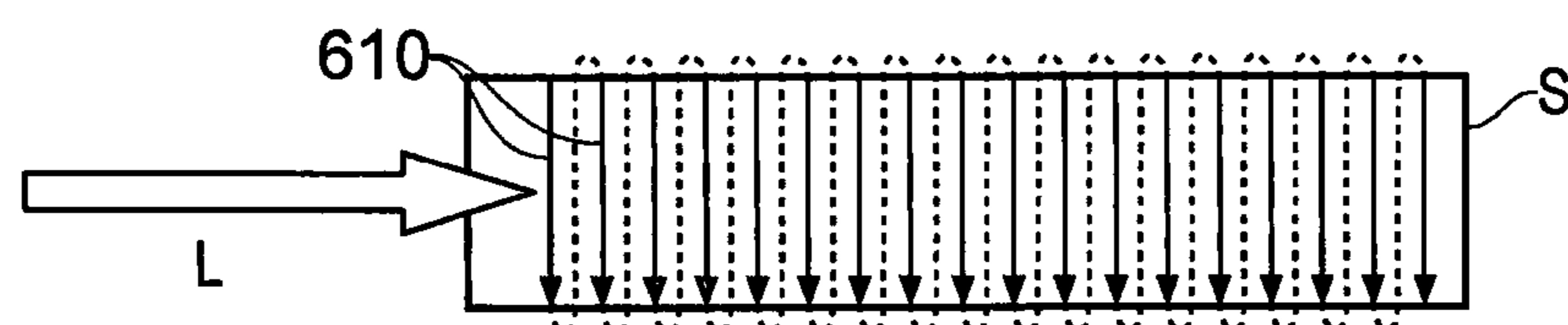

FIG. 8B

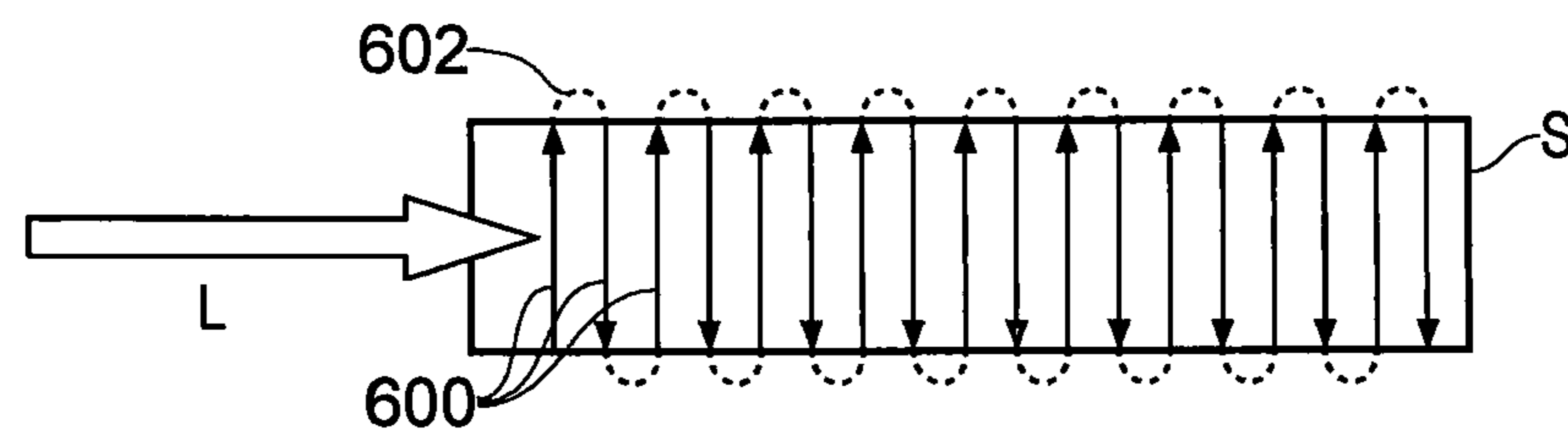

FIG. 8A

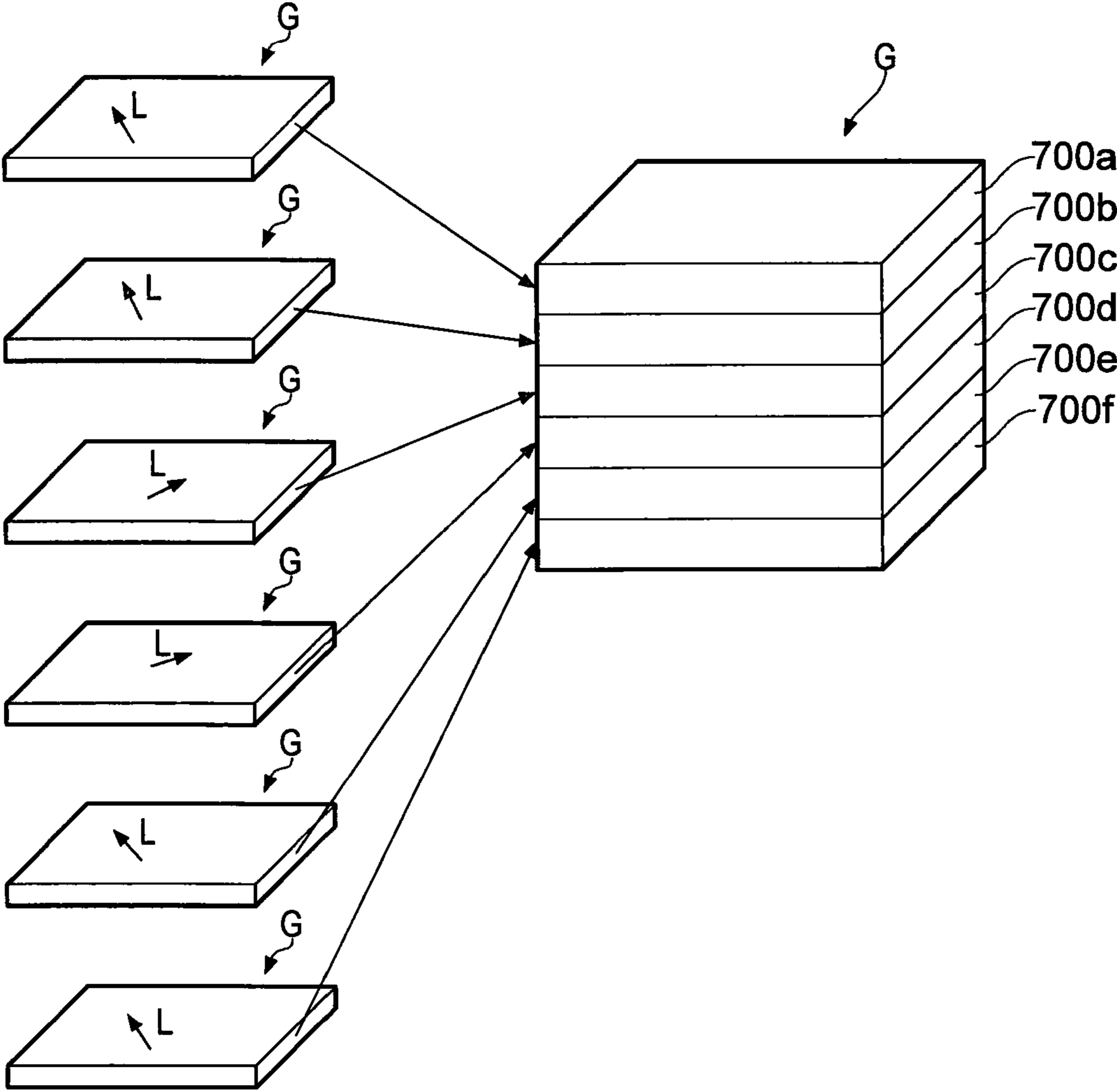

FIG. 9

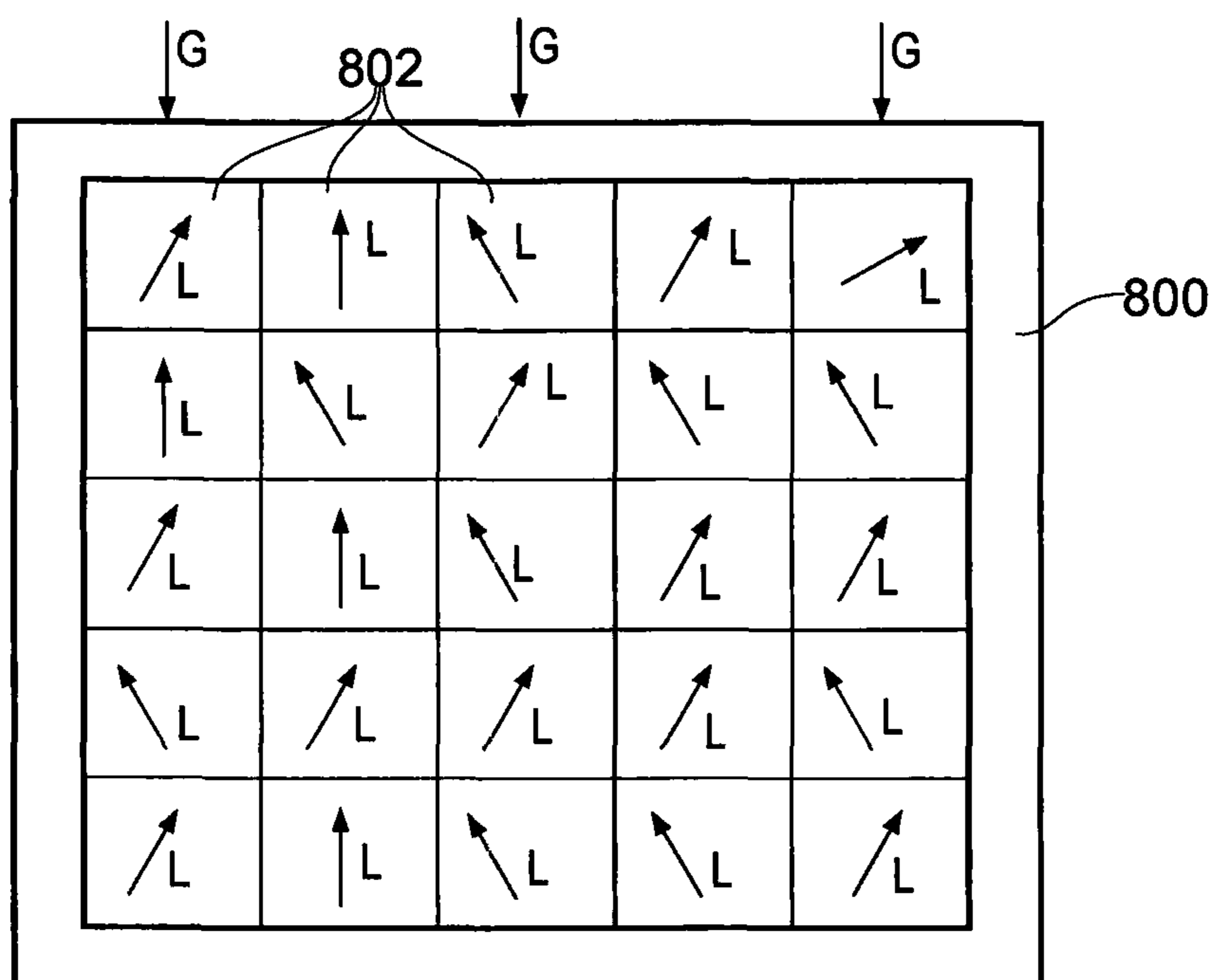

FIG. 10

## SELECTIVE LASER SOLIDIFICATION APPARATUS AND METHOD

The present invention relates to selective laser solidification and in particular to an improved selective laser melting process and apparatus in which the direction of laser movement across the powder bed is controlled relative to the direction of gas flow.

### BACKGROUND

Additive manufacturing or rapid prototyping methods for producing components comprise layer-by-layer solidification of a material, such as a metal powder material, using a laser beam. A powder layer is deposited on a powder bed in a build chamber and a laser beam is scanned across portions of the powder layer that correspond to a cross-section of the component being constructed. The laser beam melts or sinters the powder to form a solidified layer. As explained in more detail below with reference to FIG. 2, it is typical to melt or sinter the desired pattern in the powder layer using a series of stripes. In particular, it is known to advance so-called hatch lines back and forth along a plurality of stripes in turn to construct the desired pattern in the powder layer. After selective solidification of a layer, the powder bed is lowered by a thickness of the newly solidified layer and a further layer of powder is spread over the surface and solidified as required.

During the melting or sintering process, debris (e.g. condensate, unsolidified particles of powder etc) is produced within the build chamber. It is known to introduce a gas flow through the build chamber in an attempt to remove debris from the chamber in the gas flow. For example, the M270 model of machine produced by EOS GmbH, Munich, Germany, passes a flow of gas from the top of the build chamber towards the powder bed and various exhaust vents collect the gas for recirculation. The gas flow in the M270 machine is thus turbulent and has no well defined flow direction. The newer M280 model of machine produced by EOS comprises a series of gas outlet nozzles located to the rear of the powder bed that pass a flow of gas to a series of exhaust vents that are located at the front of the powder bed. In this manner, a planar layer of gas flow is created at the surface of the powder bed. This planar gas flow arrangement has, however, been found by the present inventors to produce high surface roughness and non-uniformity of the solidified metal layers generated by the melting process.

### SUMMARY OF THE INVENTION

According to a first aspect of the present invention, there is provided selective laser solidification apparatus, comprising; a powder bed onto which a powder layer can be deposited, a gas flow unit for passing a flow of gas over the powder bed along a predefined gas flow direction, and a laser scanning unit for scanning a laser beam over the powder layer to selectively solidify at least part of the powder layer to form a required pattern, the required pattern being formed from a plurality of stripes or stripe segments, each stripe or stripe segment being formed by advancing the laser beam along the stripe or stripe segment in a stripe formation direction, characterised in that the stripe formation direction is always at least partially opposed to the predefined gas flow direction.

The present invention thus relates to selective laser solidification apparatus, e.g. selective laser sintering or selective laser melting apparatus, in which a powder layer is deposited

on a powder bed. A laser scanning unit directs a laser beam onto the surface of the powder layer to solidify (e.g. melt or sinter) selected parts of the powder layer to form a required pattern (e.g. a pattern corresponding to the cross-section of a 3D object that is being constructed). This selective solidification is performed by dividing the area to be scanned by the laser beam into a plurality of stripes or stripe segments. Each stripe or stripe segment is formed by advancing the laser beam along the stripe or stripe segment in a stripe formation direction. As explained below, in a preferred embodiment the laser scanning unit rapidly moves (e.g. scans or steps) a laser spot across each stripe or stripe segment to form a hatch line which is advanced along the stripe or stripe segment in a stripe formation direction. A gas flow unit provides a flow of gas (e.g. a planar gas flow) over the powder bed whilst the stripes are being scanned.

The present inventors have discovered a number of problems that occur when using commercially available selective laser melting machines, such as the EOS M280. In particular, it has been found that debris (e.g. condensate, powder particles etc) ejected during the laser solidification (e.g. melting) process can be deposited on areas of the powder layer that have yet to be solidified. This has been found to produce additional surface roughness and the formation of layers of non-uniform thickness, which additionally create defects (e.g. pores, inclusions etc). Although altering the way in which the gas flows over the powder bed has been proposed previously, the present inventors have found that the stripe formation direction relative to the gas flow direction has a significant effect on the quality of the layer that is formed. In particular, the present inventors have found that improved powder layer formation occurs if the predefined gas flow direction is always at least partially opposed to the stripe formation direction. In other words, the apparatus can be improved by ensuring there is always a component of the vector that describes the gas flow direction that opposes the vector that defines the stripe formation direction.

It is important to note that the benefits of controlling the stripe formation direction relative to the gas flow direction had not previously been recognised by those skilled in the art. As explained below, prior art techniques typically use stripe patterns in which opposite stripe formation directions are used for adjacent stripes; this is done in order to minimise the time taken to scan a laser beam over the powder layer. For machines in which the gas flow is uncontrolled, the variation in gas flow direction relative to the stripe formation direction is random and simply leads to a general reduction in material uniformity across the powder layer. For machines in which gas flow is provided along a certain predefined direction (e.g. as per the planar flow provided in the EOS M280 machine), the alternating direction of stripe formation direction causes adjacent stripe of solidified material to have different physical properties (e.g. different densities and surface roughness). These variations are visible and produce weaknesses within three dimensional objects constructed from a plurality of such layers.

The present invention, by ensuring the predefined gas flow direction is always at least partially opposed to the stripe formation direction, allows the quality and uniformity of components made by laser solidification to be improved. Ensuring that stripe or stripe segment formation does not occur in the presence of a "tail wind" means that less ejected debris (condensate, powder particles etc) is deposited on powder that is molten or is yet to be melted. Debris is thus carried away from the melt front (i.e. the part of the stripe that is presently in the molten state) and the accumulation of debris at the melt front that is otherwise seen is avoided.

Preventing or reducing debris accumulation at the melt front, and deposition on top of regions of the powder layer that have not yet been solidified, not only improves layer thickness and process uniformity but can also improve the overall efficiency of the solidification process. In particular, preventing such a build up of debris ensures that there is no significant attenuation of the laser beam by debris before it reaches the powder layer to be solidified (thereby ensuring efficient solidification) and also prevents previously deposited debris from being re-melted and ejected again from the surface.

The present invention is characterised by the stripe formation direction always being at least partially opposed to the predefined gas flow direction. In other words, there is always a component of the stripe formation direction vector that is in the opposite direction to the gas flow direction vector. The stripe formation direction may be completely opposite (anti-parallel) to the gas flow direction or there may be an oblique angle (e.g. of less than  $80^\circ$ , more preferably of less than  $70^\circ$  or more preferably of less than  $60^\circ$ ) between the stripe formation direction and the gas flow direction. It should be noted that the sign of such an oblique angle must still be selected to ensure that stripe formation direction is always at least partially opposed to the predefined gas flow direction. Providing a stripe formation direction that is completely opposite (anti-parallel) to the gas flow direction provides optimum performance, but maintaining a single stripe formation direction when constructing objects from multiple layers may not always be desirable, as described in more detail below. Conveniently, the stripe formation direction subtends an angle ( $\alpha$ ) of at least  $10^\circ$  to the normal to the gas flow direction. More preferable, the angle ( $\alpha$ ) is at least  $15^\circ$ ,  $20^\circ$ ,  $25^\circ$ ,  $30^\circ$ ,  $35^\circ$ ,  $40^\circ$ , or  $45^\circ$ . In a preferred embodiment, the stripe formation direction subtends an angle ( $\alpha$ ) of more than  $30^\circ$  to the normal to the gas flow direction. This ensures that any hatch lines that are used to form the stripes do not become parallel or substantially parallel to the direction of gas flow.

In addition to controlling the stripe formation direction relative to the predefined gas flow direction, it has been found that the order in which the plurality of stripes or stripe segments are formed can affect the uniformity and roughness (e.g. the density) of the solidified layer. If the flow of gas over the powder bed originates from a first side of the powder bed (e.g. if a gas outlet is provided at the first side of the powder bed), it is preferred that the plurality of stripes or stripe segments are formed in reverse order of their proximity to the first side of the powder bed. Forming the stripes or stripe segments in such an order ensures that debris (e.g. condensate or ejected particles) generated at the melt front is carried by the gas flow to areas of the powder layer that have already been solidified, rather than being deposited on material that has yet to be solidified. This ensures that subsequent solidification is only of the fresh powder layer (i.e. a powder layer on which minimal debris has been deposited). This again helps improve layer thickness uniformity and reduces surface roughness, thereby reducing defects.

The gas flow unit passes gas over the powder bed along a predefined gas flow direction. The gas flow may be along a linear gas flow direction or it may be along a non-linear (e.g. curved) gas flow direction. The gas flow direction may vary as a function of the position on the powder bed. Preferably, the gas flow direction is uniform over the powder bed (e.g. a planar gas layer may be produced). The gas flow unit may comprise at least one gas outlet. The at least one gas outlet may comprise a linear bar with a plurality of

spaced apart gas nozzles. The gas flow unit may comprise at least one gas exhaust. The at least one gas exhaust may comprise a linear bar with a plurality of exhaust vents. The gas flow unit may include a gas pump. The at least one gas outlet and the at least one gas exhaust are preferably placed either side of the powder bed such that gas pumped from the at least one gas outlet passes to the at least one gas exhaust. Preferably, a substantially planar flow of gas is generated along the predefined gas direction. Preferably, a substantially laminar flow of gas is generated along the predefined gas direction. This planar or laminar flow of gas may be generated by passing gas from the at least one gas outlet passes to the at least one gas exhaust.

Advantageously, the gas flow unit generates a gas flow that moves with a velocity of at least 2 m/s over the powder bed. The gas flow rate is preferably selected so as to not disturb any deposited powder layer, but to allow ejected debris to be blown clear. Any gas, e.g. air, may be passed over the powder bed. Advantageously, an inert gas is passed over the powder bed. The inert gas may be at least one of nitrogen, argon and helium.

The required pattern may be formed from a plurality of stripes. The stripes may be elongate stripes. The plurality of stripes may comprise stripes of any shape. For example, a plurality of curved stripes may be formed. Preferably, each of the plurality of stripes comprises a linear stripe having an elongate axis. The stripe formation direction is then preferably parallel to the elongate axis of the stripe. The plurality of stripes may be formed in any order, although as described above it is preferred to form stripes in reverse order of their proximity to the source of the gas flow. The laser beam may be advanced along an entire stripe before moving on to the next stripe. In other words, selective melting of one stripe may be completed before starting to melt a different stripe. Alternatively, only a part or section of one stripe may be formed before moving onto a part or section of another stripe. It is, of course, possible for only part of a stripe to be solidified in order to define the part of the pattern that is contained within that stripe. The apparatus may include a controller for controlling the laser scanning unit that defines the plurality of stripes that are to be used. Each stripe may have a width of at least 5 mm, at least 10 mm, at least 15 mm or at least 20 mm. Each stripe may have a width of no more than 50 mm, 40 mm, 30 mm or 20 mm.

The required pattern may alternatively be formed from a plurality of stripe segments. For example, the required pattern may be formed from a regular grid of stripe segments that form a checkerboard pattern. The checkerboard pattern may comprise a plurality of square or rectangular stripe segments. The stripe segments may all be the same size or may be different sizes. An irregular pattern of stripe segments (e.g. islands) may also be formed. The formation of such stripe segments or sections is described in, for example, US2005/0142024. All the stripe segments within a layer may be formed by advancing the laser beam along the same stripe formation direction. Alternatively, a plurality of different stripe formation directions may be used for different stripe segments of a powder layer. For example, the different stripe segments may be formed using different stripe formation directions. As explained above, the present invention ensures the stripe formation direction is always at least partially opposed to the gas flow direction when writing each stripe segment.

The laser scanning unit may comprise a pulsed laser. Preferably, the laser scanning unit comprises a continuous wave (CW) laser. The laser scanning unit may include a laser beam modulator. The modulator may then modulate (e.g.

activate or deactivate) the laser beam that impinges on the powder layer. In this manner, laser solidification can be controlled by turning on and off the laser beam as required. Alternatively, the laser power may be modulated, e.g. a sine wave modulation may be applied. The laser scanning unit

may generate a laser beam of sufficient power to sinter and/or melt a powder layer. The power of the laser beam may be adjustable by a user. The laser scanning unit may generate a laser beam that is appropriately shaped (e.g. by beam shaping optics) to form a variable length laser line having a long axis that extends across the stripe or stripe segment. In such an example, the pattern within the stripe is formed by advancing the laser line along the stripe or stripe segment in the stripe formation direction. Advantageously, the laser scanning unit generates a laser spot that is moved (e.g. stepped or scanned) across the stripe to form a so-called hatch line. The laser spot may have a substantially circular cross-sectional profile (e.g. a Gaussian beam profile). The laser scanning unit may form the hatch line by rapidly moving (e.g. stepping or scanning) the spot from one side of the stripe to the other. This may be done using appropriate beam steering optics of the laser scanning unit. Preferably, each of the plurality of stripes or stripe segments are formed using a plurality of hatch lines that are advanced along the stripe formation direction. In other words, hatch lines across the stripe or stripe segment are formed in succession with each hatch line being located further along the stripe formation direction than the preceding hatch line. It should, of course, be noted that not all of the powder layer within a stripe or stripe segment may need to be melted to form the desired pattern. The formation of partial hatch lines, or the omission of hatch lines along selected parts of a stripe or stripe segment, would be possible by appropriate control of the laser scanning unit.

The apparatus may form the series of hatch lines by raster scanning the laser beam back and forth across the stripe or stripe segment. The series of hatch lines may also be formed by rapidly stepping the laser beam back and forth across the stripe or stripe segment. The formation of such bidirectional hatch lines (i.e. hatch lines formed by laser motion across the width of the stripe in two, opposite, directions) is the conventional hatch line formation technique used to form the required pattern along a stripe. As is also known, the laser beam may be deactivated when the beam steering optics are being used to reposition the laser beam from one hatch line to another.

The apparatus of the present invention may form the plurality of stripes or stripe segment using bidirectional hatch lines. Alternatively, a series of hatch lines may be formed by only moving the laser beam in the same line direction across the stripe or stripe segment. In other words, unidirectional hatch lines may be formed. Preferably, the line direction across the stripe or stripe segment is at least partially opposed to the gas flow direction. In this manner, debris ejected during hatch line formation is carried away from the direction in which the laser beam is advancing across the stripe or stripe segment. Although the improvement associated with using unidirectional hatch lines is relatively small compared to the benefits of aligning the stripe formation direction to the gas flow direction, it does still provide a useful improvement. This is, however, at the expense of significantly reducing the speed at which the hatch lines can be written.

In one embodiment, the way in which the hatch lines are formed may be varied during use. In particular, the way in which the hatch lines are formed may be selected depending on the orientation of the stripe formation direction relative to

the gas flow direction. In other words, the line direction may be selected based on the orientation of the stripe formation direction relative to the gas flow direction. If the angle ( $\alpha$ ) between the stripe formation direction and the normal to the gas flow direction is substantial (e.g. greater than  $10^\circ$ ,  $20^\circ$  or  $30^\circ$ ) then bidirectional hatch lines may be used without any substantial degradation in layer formation. However, for smaller angles (e.g. a less than  $10^\circ$ ,  $20^\circ$  or  $30^\circ$ ) it may be advantageous to use unidirectional hatch lines. In such a case, the line direction can be selected to at least partially oppose to the gas flow direction.

Apparatus of the present invention is typically used to build, layer-by-layer, three dimensional objects. The apparatus is thus preferably arranged to deposit and selectively solidify a plurality of powder layers, each layer deposited on top of the preceding layer, to form a three dimensional object. It is preferred that the layer formation technique of the present invention is applied to each layer, in turn, of the object that is formed. In particular, the required pattern of each powder layer may be formed from a plurality of stripes or stripe segments. The stripe formation direction is preferably always at least partially opposed to the predefined gas flow direction for each stripe or stripe segment of each layer. In other words, it is preferred that no stripes or stripe segments are formed that do not meet the requirement that the stripe formation direction is always at least partially opposed to the predefined gas flow direction. This ensures uniformity and tight layer thickness control throughout the three dimensional object.

It should be noted that it is possible to perform a contour scan before and/or after the required pattern has been written into a powder layer using the stripe or stripe segment based formation technique. A contour scan involves rapidly scanning the laser beam around the contour of the part to re-melt/re-solidify material that will form the outer surface of the part being formed. Such a contour scan involves the solidification of only a small amount of material thereby ejecting minimal amounts of debris and can thus be formed in a conventional manner (i.e. with no control over laser beam movement direction relative to the gas flow direction). Such a contour scan may be performed between the stripe formation technique being applied to a plurality of different powder layers.

The apparatus of the present invention preferably also includes powder deposition apparatus for depositing a powder layer onto the powder bed. The powder deposition apparatus preferably comprises a powder dispenser and a powder wiper. The powder bed may also include a moveable platform or table. A base plate may be attached to platform. The height of the platform within the machine may be adjustable to allow the powder bed to be dropped prior to the deposition of a powder layer. Such features are conventional for selective solidification machines and will not be described further herein for brevity.

It has been explained previously in U.S. Pat. No. 8,034, 279 that altering the stripe direction for different layers is advantageous when forming a three dimensional object. This also applies when using the technique of the present invention. In particular, different stripe formation directions (e.g. differing by  $30^\circ$ ) are preferably used for adjacent powder layers. As explained above, it is preferred that the stripe formation direction used for each layer is at least partially opposed to the gas flow direction.

Apparatus of the present invention may be used to selectively sinter powder. Advantageously, the apparatus of the present invention is used to selectively melt powder. The powder may, for example, comprise plastic powder, ceramic

powder or metal powder. Preferably, the apparatus is arranged to deposit and solidify metal powder. For example, metal powders such as steel (e.g. steel grade 1.2709), Stainless steel, titanium, cobalt chrome etc may be used.

According to a second aspect, the present invention provides a method of selectively solidifying a powder layer deposited on a powder bed, comprising the steps of; passing a flow of gas over the powder bed along a predefined gas flow direction, and scanning a laser beam over the powder layer to selectively solidify at least part of the powder layer to form a required pattern, the required pattern being formed from a plurality of stripes or stripe segments, each stripe or stripe segment being formed by advancing the laser beam along the stripe or stripe segment in a stripe formation direction, characterised by the stripe formation direction always being at least partially opposed to the predefined gas flow direction. The method may include any of the preferred features described for the corresponding apparatus of the first aspect of the present invention.

According to a further aspect, the invention provides selective laser melting apparatus, comprising; a powder bed onto which a layer of powder can be deposited, a gas flow device for passing a flow of gas over the powder bed along a predefined gas flow direction, and a laser scanning unit for scanning a laser beam along a scan path on a layer of powder deposited on the powder bed, the laser beam being selectively output as the scan path is traversed to allow selected regions of the layer of powder to be melted, wherein the direction along which the laser beam is moved is oriented relative to the gas flow direction so as to substantially prevent any particles ejected during laser melting from being carried by the gas flow into regions of the scan path that have yet to be scanned.

In a further aspect, the present invention extends to selective laser solidification apparatus, comprising; a powder bed onto which a powder layer can be deposited, a gas flow unit for passing a flow of gas over the powder bed along a predefined gas flow direction, and a laser scanning unit for scanning a laser beam over the powder layer to selectively solidify at least part of the powder layer to form a required pattern, the required pattern being formed from a plurality of stripes or stripe segments, wherein the flow of gas over the powder bed originates from a first side of the powder bed and the plurality of stripes or stripe segments are formed in reverse order of their proximity to the first side of the powder bed. The invention also extends to a corresponding method of operating selective laser solidification apparatus and may include any feature described herein.

In a further aspect, the present invention extends to selective laser solidification apparatus, comprising; a powder bed onto which a powder layer can be deposited, a gas flow unit for passing a flow of gas over the powder bed along a predefined gas flow direction, and a laser scanning unit for scanning a laser beam over the powder layer to selectively solidify at least part of the powder layer to form a required pattern, the required pattern being formed from a plurality of stripes or stripe segments, wherein the laser scanning unit generates a laser spot that is moved across the stripe or stripe segment to form a hatch line, each of the plurality of stripes or stripe segments being formed using a plurality of hatch lines that are advanced along the stripe formation direction, characterised in that all hatch lines are formed by moving the laser beam in the same line direction across the stripe or stripe segment, the line direction being at least partially opposed to the gas flow direction. The invention also

extends to a corresponding method of operating selective laser solidification apparatus and may include any feature described herein.

In a further aspect, the present invention extends to selective laser solidification apparatus, comprising; a powder bed onto which a powder layer can be deposited, a gas flow unit for passing a flow of gas over the powder bed along a gas flow direction and, a laser scanning unit for moving a laser beam over the powder layer to selectively solidify at least part of the powder layer to form a required pattern, wherein the laser scanning unit moves the laser beam to form a series of hatch lines that are advanced over the powder layer along a hatch line movement direction, wherein the hatch line movement direction is at least partially opposed to the gas flow direction. The hatch lines may be used to form stripes, segments, shells or any shape. The hatch line movement direction may be different for different areas on the powder bed. The invention also extends to a corresponding method of operating selective laser solidification apparatus and may include any feature described herein.

#### BRIEF DESCRIPTION OF THE DRAWINGS

The invention will now be described, by way of example only, with reference to the accompanying drawings in which:

FIG. 1 is a schematic illustration of a selective laser melting machine,

FIG. 2 shows a prior art technique for solidifying a layer of powder using hatch lines advanced along twelve stripes,

FIG. 3 is a photomicrograph that shows the variation in oxidation that occurs using the prior art technique of FIG. 2,

FIG. 4 illustrates the deposition of ejected material that occurs when the gas flow is in the same direction as the stripe formation direction (the "tail-wind" situation),

FIG. 5 illustrates the deposition of ejected material that occurs when the gas flow direction opposes the stripe formation direction as per the present invention,

FIG. 6 shows a first example of a stripe scan of the present invention,

FIG. 7 shows a second example of a stripe scan of the present invention,

FIGS. 8A, 8B and 8C show three options for forming hatch lines by rapid scanning of a laser beam across the width a stripe,

FIG. 9 illustrates how the stripe formation direction can be varied between layers, and

FIG. 10 illustrates how multiple stripe segments may be formed within a layer in a checkerboard pattern.

#### DETAILED DESCRIPTION

Referring to FIG. 1, a known selective laser melting machine 2 is schematically illustrated.

The laser melting machine 2 comprises a build chamber or housing 4 in which there is provided a powder bed 6. The powder bed 6 can be raised and lowered (i.e. moved in the z-direction) by a piston mechanism 8. A powder dispensing and roller system 10 is provided for depositing a thin (e.g. 10-100 µm) powder layer onto the top of the powder bed 6. The powder used to form the powder layer is preferably a metal powder (e.g. 1.2709 grade steel powder).

A laser scanning unit 20 is also provided that comprises a high power continuous wave (CW) laser and scanning optics to direct a laser beam 22 towards the powder bed 6.

The scanning optics also allow the laser beam **22** to be moved rapidly over the surface of the powder bed **6**. The laser scanning unit **20** also includes an optical modulator to enable the laser beam **22** that impinges on the powder layer to be turned on and off as required.

A gas flow unit **30** is also provided. The gas flow unit **30** comprises a gas outlet bar **32** having a plurality of nozzles **34** for ejecting gas. A gas exhaust bar **36** is also provided for collecting gas. A pump **38** is used to draw in gas from the gas exhaust bar **36** and to pump gas to the nozzles **34** of the gas outlet bar **32**. Suitable gas tubing **40** is provided to connect the gas outlet bar **32** and gas exhaust bar **36** to the pump **38**. In use, gas flows from the gas outlet bar **32** to the gas exhaust bar **36**. There is thus a predefined gas flow within the machine; i.e. gas is passed over the powder bed along the gas flow direction **G**.

The laser melting machine **2** is operated, under the direction of a controller **50**, as follows. Firstly, a substrate plate is affixed to the piston mechanism. The substrate plate, which is preferably formed from the same material as the powder to be deposited on it, forms the base of the powder bed. The powder dispensing and roller system **10** is then used to dispense a powder layer of a certain thickness (e.g. 80  $\mu\text{m}$ ) onto the substrate plate. The laser scanning unit **20** then directs the laser beam **22** onto the powder layer and melts selected parts of the powder layer; i.e. selected regions of the powder layer are melted to the substrate plate. The path over the powder bed that is used by the laser is scanned is described in more detail below. Once the required pattern (e.g. cross-section) has been written into the powder layer, the piston **8** drops the powder bed **6**, another powder layer is deposited on top of the existing (partly solidified) layer and the laser scanning unit then selectively melts the newly deposited powder layer. This process is then repeated, layer-by-layer, to form the required three dimensional object. During this fabrication process, a continuous supply of gas is passed over the powder bed along the gas flow direction **G** by the gas flow unit **30**.

The illustration and description of FIG. **1** shows only the basic operation of known laser melting machines. The skilled person would be aware of further details of the machine construction and operation. It should be noted that the above schematic illustration is based on the M280 model of laser melting machine that is made by EOS GmbH.

Referring next to FIG. **2**, a prior art process for selectively melting a deposited powder layer using the machine described above with reference to FIG. **1** will be described. This process is implemented as standard on the EOS M280 machine mentioned above.

FIG. **2** illustrates a powder layer **100** that is to be selectively melted to form the solidified layer pattern **102**. The powder layer **100** is deposited on the powder bed using the powder dispensing and roller system **10** that is described with reference to FIG. **1**. Also shown is the gas outlet bar **32** and the gas exhaust bar **36** that provide a planar flow of gas along a gas flow direction **G**.

In order to solidify the powder layer **100** to form the solidified layer pattern **102**, a plurality of stripes (labelled **S1-S12** in FIG. **2**) are defined. The stripes **S1-S12** together define a square region that contains the area on the powder bed where the solidified layer pattern **102** is to be written. The laser scanning unit **20** generates a laser spot that is rapidly scanned across the width of the stripe (i.e. along a direction perpendicular to the elongate axis or length of the stripe) to form a so-called hatch line. In order to selectively melt powder along the length of the stripe, successive hatch lines are moved along the stripe in the direction **L**. In other

words, the stripe is formed by movement of the hatch line along the stripe formation direction **L**. It should be noted that the hatch line formed by the laser may be the width of the stripe or it may be shorter than the width of the stripe if melting is not required across the whole stripe width at that particular position.

In the prior art example shown in FIG. **2**, the stripe **S12** is addressed first. This involves the laser scanning unit forming a hatch line that is moved from left to right along the stripe formation direction **L** to solidify the part of the layer pattern **102** falling with the **S12** stripe. After stripe **S12** has been written, the pattern of stripe **S11** is written, which involves moving the hatch line along the stripe **S11** in the stripe formation direction **L**. The stripe formation direction **L** for stripe **S11** is opposite to the stripe formation direction **L** for stripe **S12**. It can thus be seen that the stripe formation direction **L** alternates between stripes as the stripes are written in turn (i.e. in the order **S12** to **S1**). In the present example, all even numbered stripes (**S2**, **S4**, **S4** etc) are formed using a hatch line that is moved from left to right whereas all odd numbered stripes (**S1**, **S3**, **S5** etc) are formed using a hatch line that is moved from right to left.

The present inventors have found that this prior art technique has a number of disadvantages. As shown in FIG. **3**, it has been found by the present inventors that stripes formed by hatch line movement in opposed stripe formation directions have different surface discoloration and surface roughness. In particular, the present inventors have found that oxidization and high surface roughness occurs for even numbered stripes (**S2**, **S4**, **S4** etc) that have been formed using a hatch line that is moved (in FIG. **2**) from left to right. These even numbered stripes are identified by the label **140** in the photomicrograph of FIG. **3**.

Referring now to FIGS. **4** and **5**, the effect of the gas flow direction relative to the stripe formation direction on layer formation will be described.

FIG. **4** shows a powder bed **200** that carries a layer of melted metal **202** and a powder layer **204** that has yet to be melted. The dashed lines **206** illustrate the hatch lines that were generated by the laser scanning unit to melt the powder that now forms the layer of melted metal **202**. In this example, the gas flow direction **G** is the same as the stripe formation direction **L**. In other words, there a component of the gas flow direction that is in the same direction as the stripe formation direction **L**; this could be thought of as there being a "tail-wind".

The inventors have found that when the gas flow direction **G** and stripe formation direction **L** are aligned in the manner shown in FIG. **4**, debris from the melting process (powder particles, partially melted clumps of powder particles and other residue/condensate from the melting process etc) are carried by the gas flow towards the part of the powder layer that has yet to be melted. This debris forms a surface region or bulge of contaminant **208** that moves along the stripe as the melt progresses. This not only results in a layer of non-uniform thickness being formed because of the different sized particles being deposited on the top of the unmelted powder, but it also reduces the laser power that reaches the powder layer thereby altering the melting conditions of the underlying powder layer. In particular, it has been found that sub-optimum oxidisation of the melted powder occurs and that the process generates a relatively high level of surface roughness and introduces defects etc. The effect shown in FIG. **4** accounts for the poorer quality of the even numbered stripes (**S2**, **S4**, **S4** etc) shown in the photomicrograph of FIG. **3**.



FIG. 5 shows a powder bed **300** that carries a layer of melted metal **302** and a powder layer **304** that has yet to be melted. The dashed lines **306** illustrate the hatch lines that were generated by the laser scanning unit to melt the powder that now forms the layer of melted metal **302**. In this example, the gas flow direction **G** is opposed to the stripe formation direction **L**. In other words, there is no component of the gas flow direction that is in the same direction as the stripe formation direction **L**; i.e. there is no “tail-wind”.

In this example, the flow of gas in the gas flow direction **G** acts to blow debris from the melting process away from the powder layer of the stripe that has yet to be melted. This has been found to prevent the formation of a bulge of contaminant as illustrated in FIG. 4. It should be noted that although FIG. 5 illustrates the use of gas flow direction **G** that is fully opposed to the stripe formation direction **L**, there may instead be an oblique angle between the gas flow direction **G** and the stripe formation direction **L**. Providing such an oblique angle also ensures that the debris is not deposited onto regions of the stripe that have just been melted.

It should also be noted FIGS. 4 and 5 illustrate embodiments in which the whole width of the stripe is melted by a plurality of full width hatch lines that are formed at successive points along the stripe formation direction **L**. It is, of course, possible to only melt selected parts of each stripe in order to construct the desired cross-section or pattern of melted material.

FIG. 6 illustrates the powder layer **400** that is to be selectively melted to form the solidified layer pattern **402**. The powder layer **400** is deposited on the powder bed using the powder dispensing and roller system that is described with reference to FIG. 1. Also shown are the gas outlet bar **32** and gas exhaust bar **36** described with reference to FIG. 1 that provide a flow of gas along a gas flow direction **G**.

In order to solidify the powder layer **400** to form the solidified layer pattern **402**, a plurality of stripes are melted in turn; these stripes are labelled as **S1-S12** in FIG. 6. Unlike the prior art process described above with reference to FIG. 2, the stripes illustrated in FIG. 6 formed by moving the hatch line along each stripe in the same direction. In other words, the same stripe formation direction **L** is used for each of the stripes **S1** to **S12**. In addition, the stripe formation direction **L** is arranged to differ from the gas flow direction **G** by the angle  $\theta$ , which in this example is about  $125^\circ$ . Also shown in FIG. 6 is the angle  $\alpha$  between the normal to the gas flow direction **G** and the stripe formation direction **L**. In this example,  $\alpha$  has a value of around  $35^\circ$ .

Providing such an angle between the gas flow direction **G** and the stripe formation direction **L** means that any debris ejected during the melting process is carried by the flow of gas away from the part of the powder layer that is yet to be melted and also away from any material of that stripe that has just been melted. For example, debris ejected from the surface when melting the point **P** shown in FIG. 6 is carried along the vector **d** and away from the stripe **S1**. This helps ensure that the majority of the debris does not cover powder yet to be sintered and also does not adhere to powder that has recently been melted. The solidified layer pattern **402** formed by the melting process thus has a more uniform (less rough, fewer defects) surface than layers produced using alternating stripe formation directions as per the prior art process described with reference to FIG. 2.

In addition to each stripe being formed by moving a hatch line along the same stripe formation direction **L**, the stripes **S1** to **S12** are preferably formed in a specific order. In particular, the stripes **S1** to **S12** are preferably formed in

reverse order of their proximity to the gas outlet bar **32**. In other words, the stripe **S1** nearest the gas exhaust bar **36** is formed first, then stripe **S2** is formed, then stripe **S3** etc. Forming the stripes in this order has the advantage that any debris ejected when writing one stripe does not disrupt the powder layer for stripes that have yet to be written. In particular, it can be seen that any debris ejected whilst melting the selected parts of the powder layer within stripe **S1** does not get carried in the flow of gas over the stripes **S2-S12**. This means that a more uniform, substantially debris free, powder layer is present when each stripe is written.

Referring to FIG. 7, a powder layer **500** is shown that is to be selectively melted to form the solidified layer pattern **502**. The powder layer **500** is deposited on the powder bed using the powder dispensing and roller system that is described with reference to FIG. 1. Also shown are the gas outlet bar **32** and gas exhaust bar **36** described with reference to FIG. 1 that provide a flow of gas along a gas flow direction **G**.

In this example, the stripes **S1** to **S12** are again preferably formed in reverse order of their proximity to the gas outlet bar **32**. Each stripe is formed by moving the hatch line along each stripe in the same direction. In other words, the same stripe formation direction **L** is used for each of the stripes **S1** to **S12**. It can also be seen that the stripe formation direction **L** of FIG. 7 is a reflection of the stripe formation direction **L** shown in FIG. 6 about the gas flow direction. In other words, the stripe formation direction **L** is arranged to differ from the gas flow direction **G** by the angle  $-\theta$  in FIG. 7. The arrangement of 7 thus has similar benefits to that of FIG. 6.

In addition to optimising the stripe formation direction **L**, it should be remembered that each stripe is preferably formed using a series of hatch lines. These hatch lines are formed by scanning a laser spot across the stripe; i.e. the hatch line is formed by moving a laser spot along a line that is perpendicular to the stripe formation direction **L**. It has further been found that a further improvement to the uniformity of stripe formation can be obtained by altering the hatch line formation process. This will now be explained with reference to FIGS. 8A, 8B and 8C.

Referring to FIG. 8A, there is shown a prior art method for scanning a laser spot back and forth across the width of a stripe **S** to form a succession of hatch lines **600** along the stripe formation direction **L**. The dashed lines **602** illustrate the notional paths at the end of each hatch line **600** that are traversed (with the laser beam deactivated) in order to appropriately position the laser beam ready for formation of the next hatch line. For convenience, the series of hatch lines of FIG. 8A can be termed bidirectional hatch lines.

The technique of hatch line formation shown in FIG. 8A has the advantage that the successive hatch lines can be formed at high speed because the beam steering optics of the laser scanning unit only need to provide a small amount of (notional) laser beam movement between the end of one hatch line and the start of the next hatch line. It has been found, however, that the direction of hatch line formation relative to the gas flow direction can also affect the quality and uniformity of the layer that is generated from melting the powder layer within a stripe. It has also been found that the non-uniformity caused by this effect increases as the magnitude of the angle  $\alpha$  (which is described above with reference to FIGS. 6 and 7) between the normal to the gas flow direction **G** and the stripe formation direction **L** reduces.

Forming the hatch lines by always scanning the laser beam in the same direction across the stripe can thus

improve the uniformity of the melted layer. FIG. 8B shows how hatch lines 610 can be formed by always scanning the laser spot from the top to the bottom of a stripe S. FIG. 8C shows how hatch lines 620 can be formed by always scanning the laser spot from the bottom to the top of a stripe S. For convenience, the series of hatch lines of FIGS. 8B and 8C can be termed unidirectional hatch lines. Although the formation of unidirectional hatch lines can improve stripe quality, such an improvement is accompanied by an increase in the time it takes to form a series of hatch lines. In particular, there is an additional delay associated with the scanning optics of the laser scanning unit moving back across the stripe to allow the next hatch line to be formed. It is thus preferable to only use unidirectional hatch lines when they provide a sufficiently significant improvement; e.g. when the magnitude of the angle  $\alpha$  between the normal to the gas flow direction G and the stripe formation direction L reduces sufficiently so that the formation of unidirectional hatch lines has a benefit.

It should also be noted that the direction of formation of the unidirectional hatch lines relative to the stripe formation direction L will depend on the orientation of the stripe being formed relative to the gas flow direction G. For example, the stripes formed in FIG. 6 would benefit from being formed from the unidirectional hatch lines of FIG. 8B whilst the stripes formed in FIG. 7 would benefit from being formed from the unidirectional hatch lines of FIG. 8C. In both cases, the direction of beam movement during hatch line formation is arranged to at least partly oppose the gas flow direction G. This means that the majority of debris associated with powder melting is blown clear of powder within the hatch line that is yet to be melted. The formation of bidirectional or unidirectional hatch lines may thus be varied as required for different stripe orientations relative to the gas flow direction.

Referring to FIG. 9, the process of constructing a three dimensional object 710 from a plurality of melted layers (700a-700f) is illustrated. Each layer 700a-700f may be formed by a process that involves selectively melting each layer using multiple stripes, each stripe of one layer being formed along a common stripe formation direction L. The stripe formation direction L may vary between layers, but it is preferred that the gas flow direction is always at least partially opposed to the stripe formation direction for each layer. In this manner, the benefits of the present invention are obtained for each layer in a three dimensional object. The use of different stripe formation directions L for each layer may also mean that certain layers can be formed using bidirectional hatch lines whilst other layers are formed using unidirectional hatch lines. The benefits of altering the stripe formation direction between layers has also been described previously in U.S. Pat. No. 8,034,279 (EOS). A difference in stripe formation direction between adjacent layers of at least 30° is used in this example, but other different angles may be implemented. For example, the rotation angle between adjacent layers may be more than 40° or it may be 67°. The rotation angle between adjacent layers is preferably less than 80°. Again, it should be noted that it is preferred that each layer (or at least the majority of the layers) meets the requirement that the gas flow direction is always at least partially opposed to the stripe formation direction.

It should also be noted that although the melting process may take place by advancing hatch lines along a stripe, there may be other processing steps that do not require such tight control over the stripe formation direction relative to the gas flow direction. For example, the laser scanning unit may perform a contour scan before and/or after a layer has been

melted by advancing hatch lines along a stripe. The contour scan may simply scan the laser beam around the contour of an object to re-melt and solidify the metal to improve surface quality. In such a contour scan the path of the laser beam spot may take on any orientation relative to the gas flow direction. This has not been found to have a detrimental effect because the amount of debris generated by such a contour scan is minimal.

Referring to FIG. 10, it is also illustrated how the present invention can be applied to layer formation using stripe segments. In particular, FIG. 10 illustrates a powder layer 800 that is to be melted to form a desired pattern (not shown). The powder layer 800 may be deposited using the powder dispensing and roller system described with reference to FIG. 1. As described previously, a planar flow of gas is provided over the powder layer along the direction G.

The desired pattern is written to the powder layer 800 by dividing the layer into a plurality of stripe segments 802. Each stripe segment 802 is formed separately. The stripe segments may be written in any order. As also shown in FIG. 10, the stripe formation direction L may be different for the different stripe segments (although it may be the same). However, the gas flow direction G is always at least partially opposed to the stripe formation direction L of each stripe segment.

The stripe segments shown in FIG. 10 are equally sized and regularly arranged in a grid or checkerboard type pattern. It is, however, possible for the stripe segments or sections to be different shapes and/or sizes. The stripe segments may also be spaced irregularly. For example, stripe segments may be provided as shells or islands formed in local areas on the substrate. The stripe segments or sections may also comprise any of the arrangements described previously in US2005/0142024 (but with the gas flow direction controlled relative to the stripe formation direction in accordance with the present invention).

The skilled person would also recognise the other variations and additions to the technique of the present inventions that are possible.

The invention claimed is:

1. A method of selectively melting a plurality of powder layers deposited on a powder bed to form a three-dimensional object, comprising the steps of:

passing a substantially planar flow of gas over the powder bed along a predefined gas flow direction; and

scanning a laser beam over each of the plurality of powder layers to selectively melt at least part of each of the powder layers to form a required pattern, the required pattern of each of the powder layers being formed from a plurality of stripes or stripe segments, and each stripe or stripe segment being formed by advancing the laser beam along the stripe or stripe segment in a stripe formation direction,

wherein the stripe formation direction is always at least partially opposed to the predefined gas flow direction for each stripe or stripe segment of each of the plurality of powder layers.

2. The method of selectively melting a plurality of powder layers according to claim 1, wherein the stripe formation direction subtends an angle ( $\alpha$ ) of more than 30° to the normal to the predefined gas flow direction.

3. The method of selectively melting a plurality of powder layers according to claim 1, wherein:

the flow of gas over the powder bed originates from a first side of the powder bed, and

**15**

the plurality of stripes or stripe segments of each of the powder layers are formed in reverse order of their proximity to the first side of the powder bed.

4. The method of selectively melting a plurality of powder layers according to claim 1, wherein the required pattern of each of the powder layers is formed from a plurality of elongate stripes.

5. The method of selectively melting a plurality of powder layers according to claim 4, wherein:

each of the plurality of elongate stripes comprises a linear stripe having an elongate axis, and the stripe formation direction is parallel to the elongate axis.

6. The method of selectively melting a plurality of powder layers according to claim 1, wherein the required pattern of each of the powder layers is formed from a plurality of stripe segments.

7. The method of selectively melting a plurality of powder layers according to claim 1, further comprising moving a laser spot across each of the plurality of stripes or stripe segments to form a plurality of hatch lines that are advanced along the stripe formation direction.

**16**

8. The method of selectively melting a plurality of powder layers according to claim 7, wherein the plurality of hatch lines of each of the plurality of stripes or stripe segments are formed by moving the laser beam back and forth across the stripe or stripe segment.

9. The method of selectively melting a plurality of powder layers according to claim 7, wherein all hatch lines of each of the plurality of stripes or stripe segments are formed by moving the laser beam in the same line direction across the stripe or stripe segment, the line direction being at least partially opposed to the predefined gas flow direction.

10. The method of selectively melting a plurality of powder layers according to claim 9, wherein the line direction is selected based on the orientation of the stripe formation direction relative to the predefined gas flow direction.

11. The method of selectively melting a plurality of powder layers according to claim 1, wherein different stripe formation directions are used for adjacent ones of the plurality of powder layers.

\* \* \* \* \*