



US010488625B2

(12) **United States Patent**  
**Lin et al.**

(10) **Patent No.:** **US 10,488,625 B2**  
(45) **Date of Patent:** **Nov. 26, 2019**

(54) **IMAGE CAPTURING LENS ASSEMBLY,  
IMAGE CAPTURING DEVICE AND  
VEHICLE PHOTOGRAPHING TERMINAL**

(71) Applicant: **LARGAN PRECISION CO., LTD.**,  
Taichung (TW)

(72) Inventors: **Cheng-Chen Lin**, Taichung (TW);  
**Wei-Yu Chen**, Taichung (TW)

(73) Assignee: **LARGAN PRECISION CO., LTD.**,  
Taichung (TW)

(\*) Notice: Subject to any disclaimer, the term of this  
patent is extended or adjusted under 35  
U.S.C. 154(b) by 0 days.

(21) Appl. No.: **15/861,484**

(22) Filed: **Jan. 3, 2018**

(65) **Prior Publication Data**  
US 2018/0129024 A1 May 10, 2018

**Related U.S. Application Data**

(63) Continuation of application No. 15/439,936, filed on  
Feb. 22, 2017, now Pat. No. 9,897,785, which is a  
continuation of application No. 14/196,621, filed on  
Mar. 4, 2014, now Pat. No. 9,602,731.

(30) **Foreign Application Priority Data**  
Jan. 17, 2014 (TW) ..... 103101848 A

(51) **Int. Cl.**  
**G02B 13/18** (2006.01)  
**G02B 9/62** (2006.01)  
**G02B 13/00** (2006.01)  
**H04N 5/232** (2006.01)  
**G02B 13/04** (2006.01)

(52) **U.S. Cl.**  
CPC ..... **G02B 13/0045** (2013.01); **G02B 9/62**  
(2013.01); **G02B 13/04** (2013.01); **H04N**  
**5/23296** (2013.01)

(58) **Field of Classification Search**  
CPC ..... G02B 9/62; G02B 13/0045  
USPC ..... 359/708, 713, 752, 756, 761  
See application file for complete search history.

(56) **References Cited**

**U.S. PATENT DOCUMENTS**

8,335,043 B2 12/2012 Huang

**FOREIGN PATENT DOCUMENTS**

TW I407184 B 9/2013

*Primary Examiner* — William Choi

(74) *Attorney, Agent, or Firm* — Maschoff Brennan

(57) **ABSTRACT**

An image capturing lens assembly includes, in order from an object side to an image side, a first lens element, a second lens element, a third lens element, a fourth lens element, a fifth lens element, and a sixth lens element. The first lens element with negative refractive power has an image-side surface being concave in a paraxial region thereof. The second and third lens elements have refractive power. The fourth lens element has positive refractive power. The fifth lens element with negative refractive power has an object-side surface being concave in a paraxial region thereof. The sixth lens element with refractive power has an object-side surface being convex in a paraxial region thereof and an image-side surface being concave in a paraxial region thereof. The image capturing lens assembly has a total of six lens elements with refractive power.

**37 Claims, 15 Drawing Sheets**

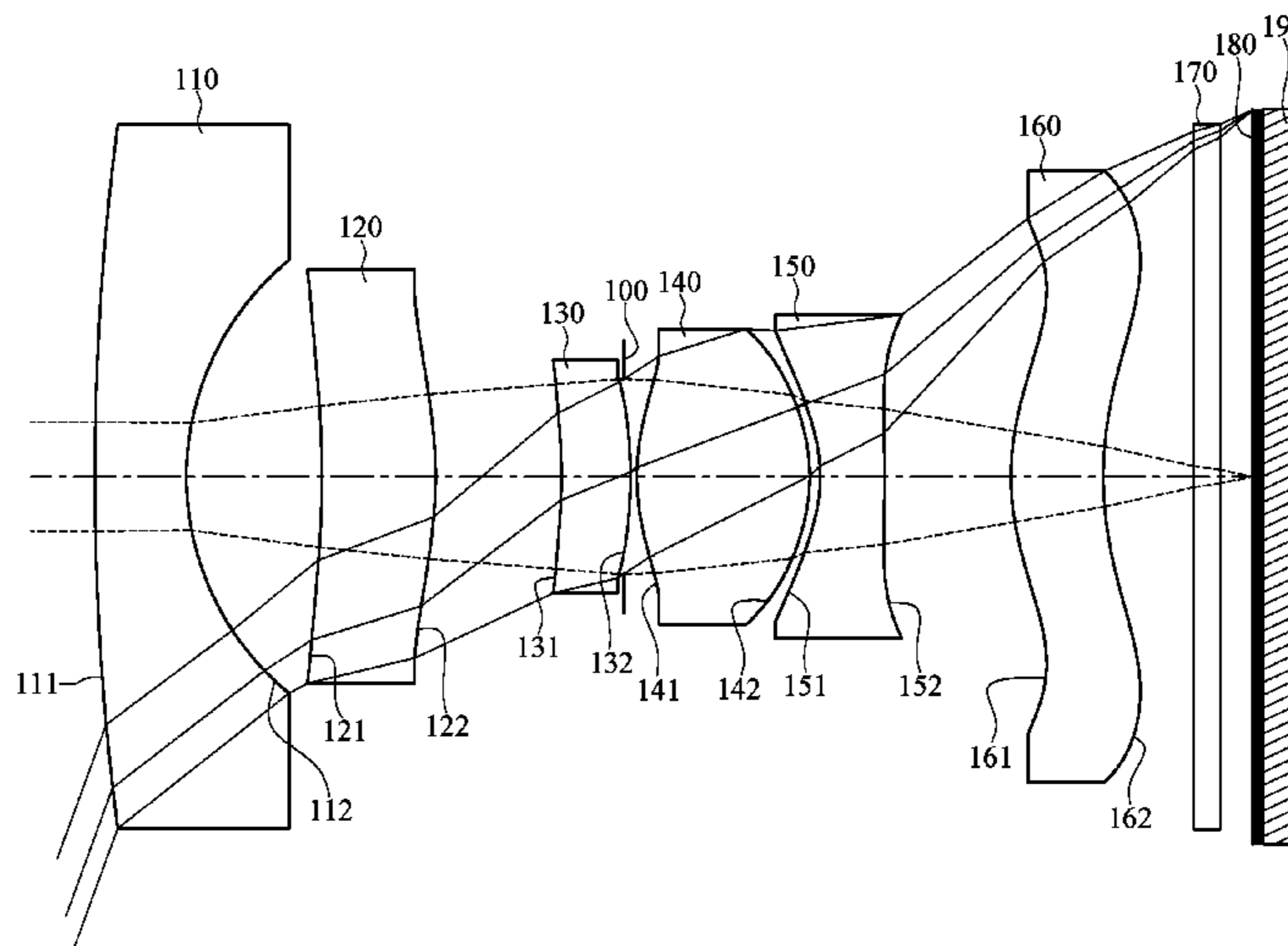

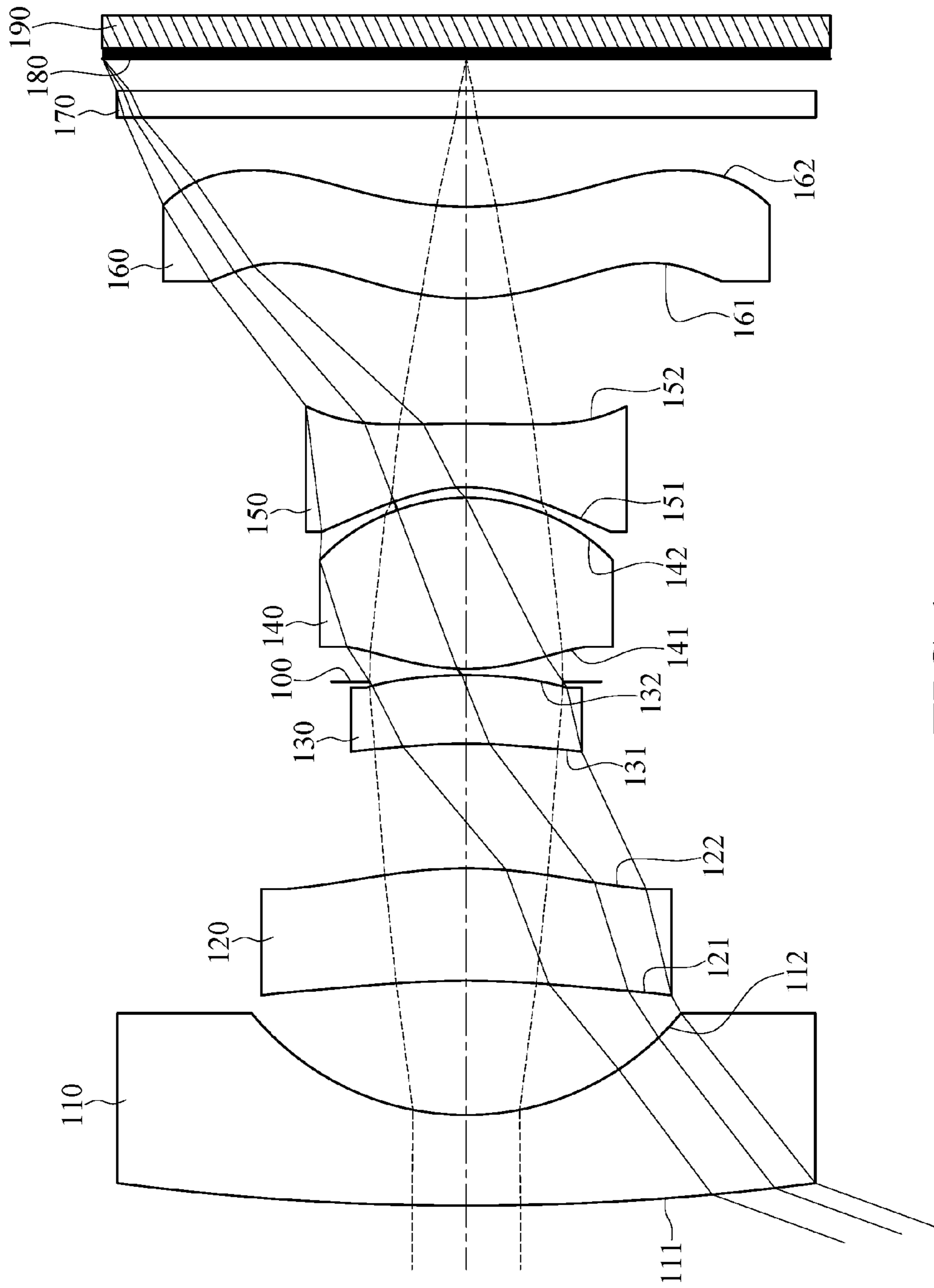

FIG.1

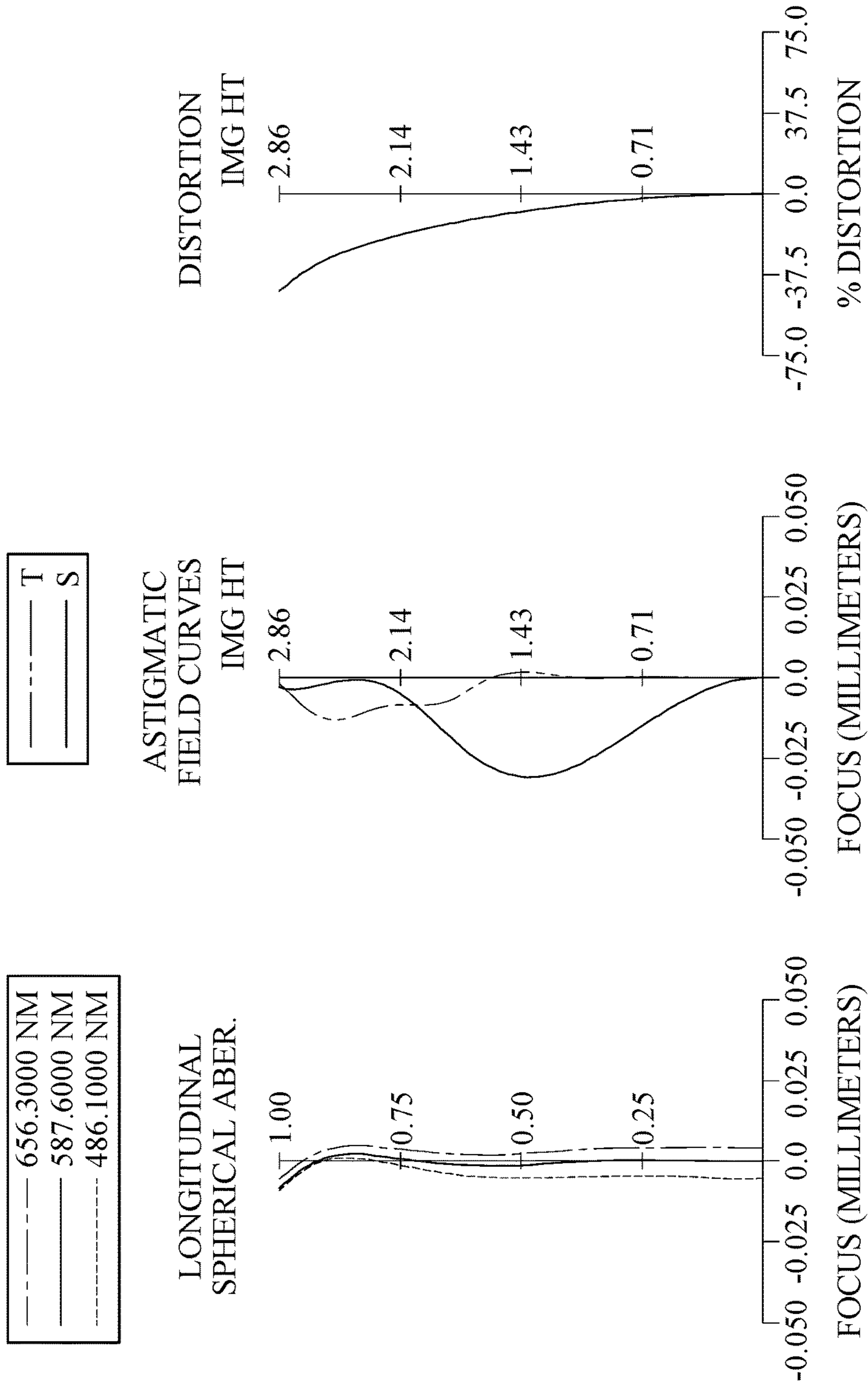

FIG.2

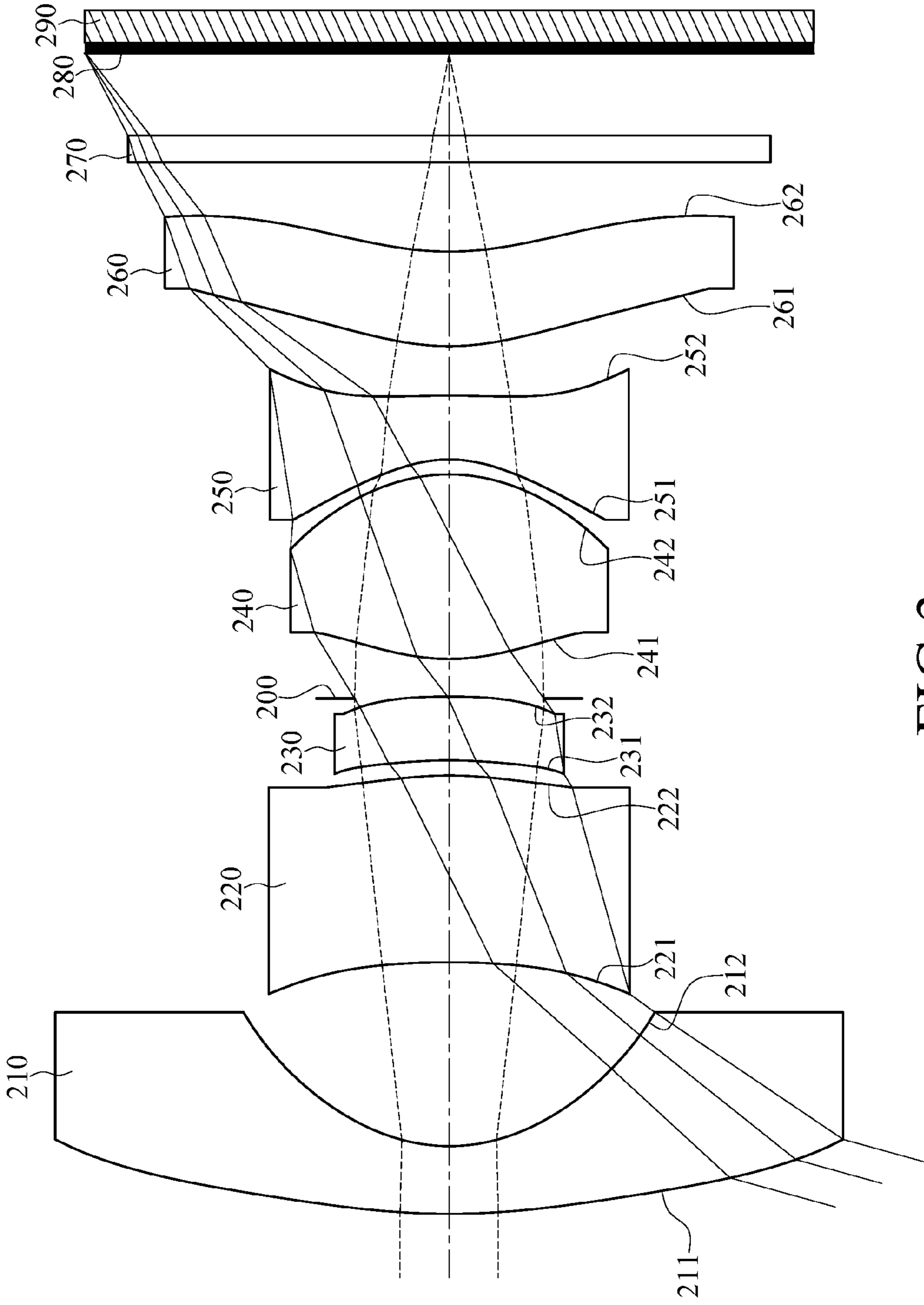

FIG.3

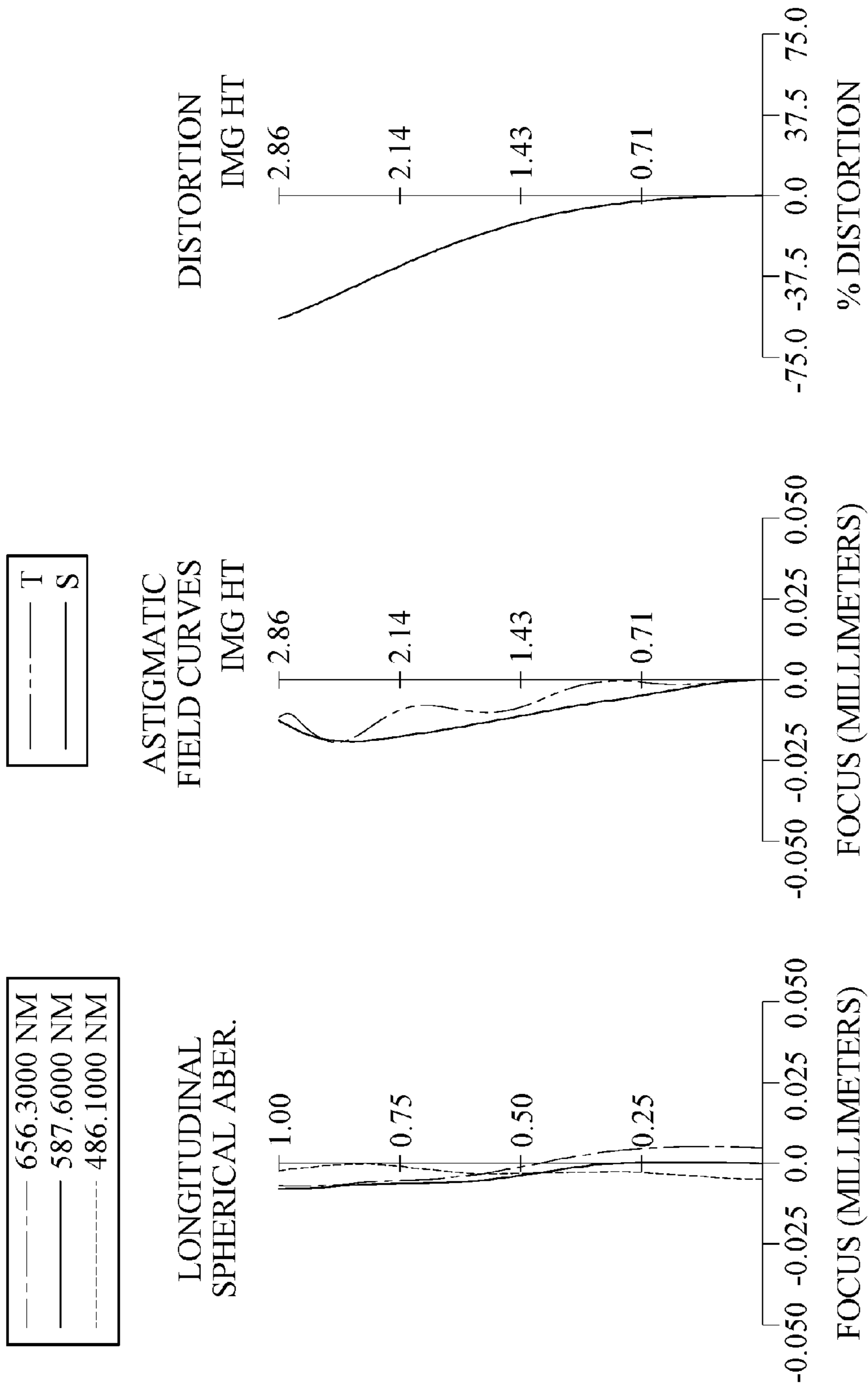

FIG.4

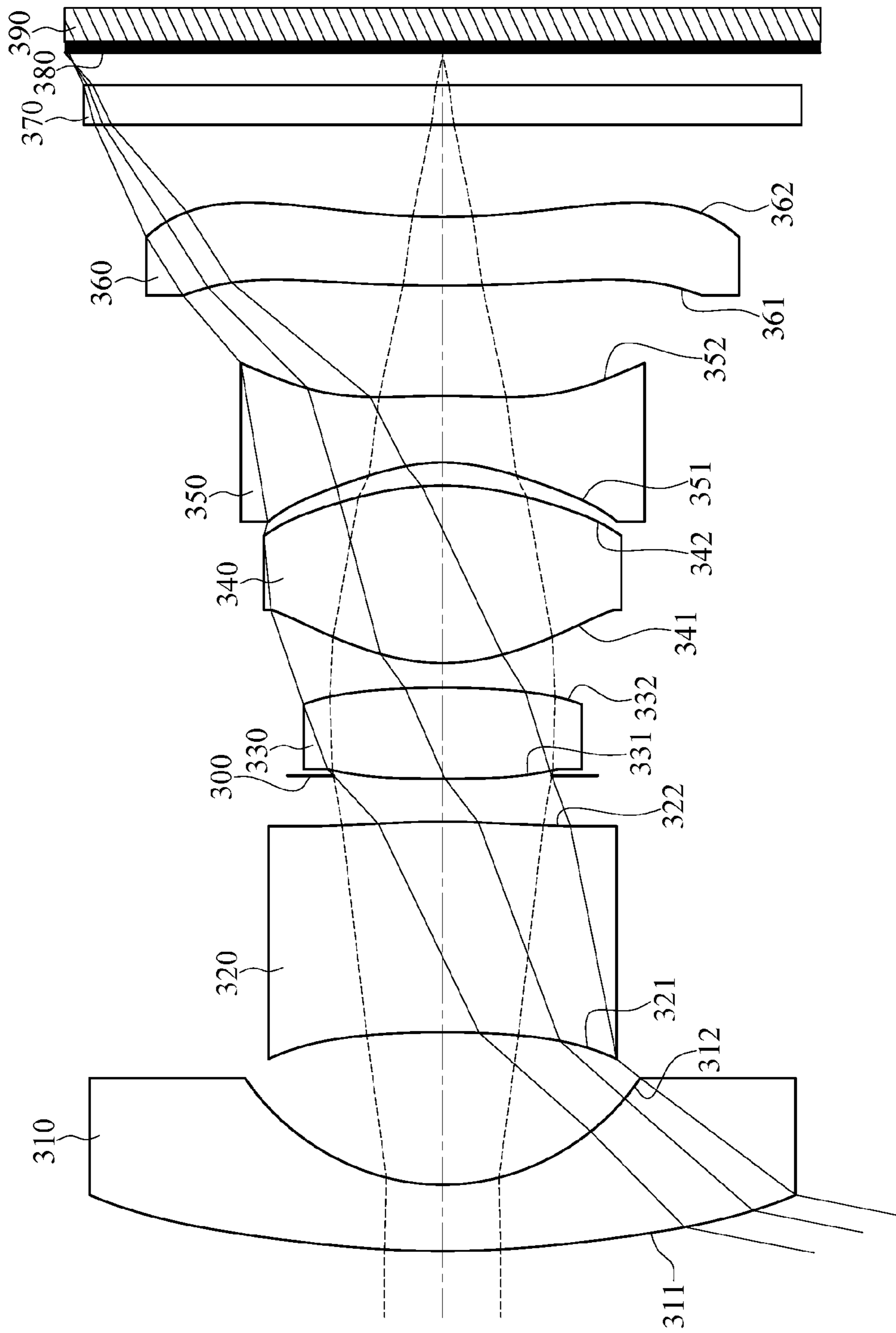

FIG.5

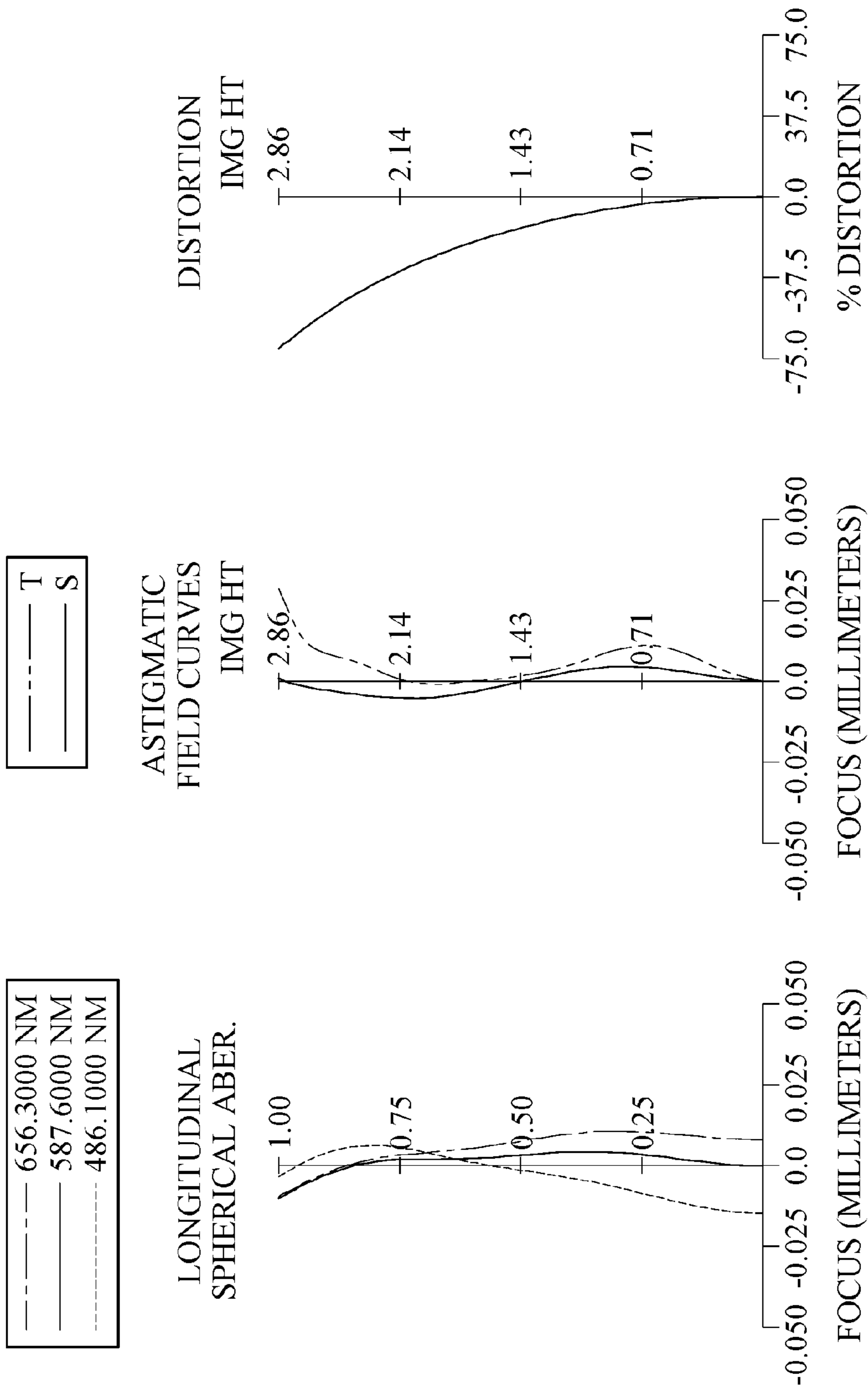

FIG.6

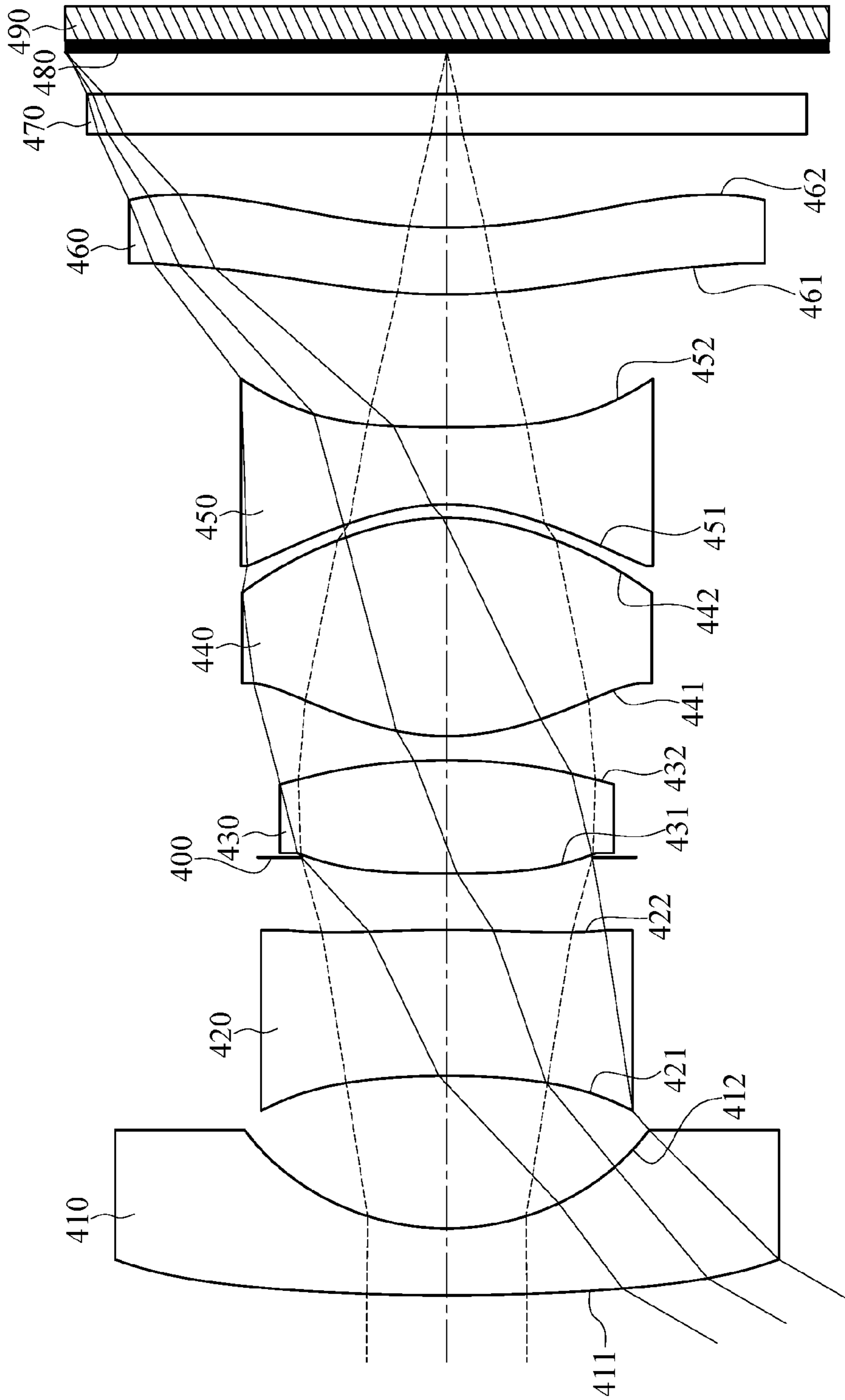

FIG.7



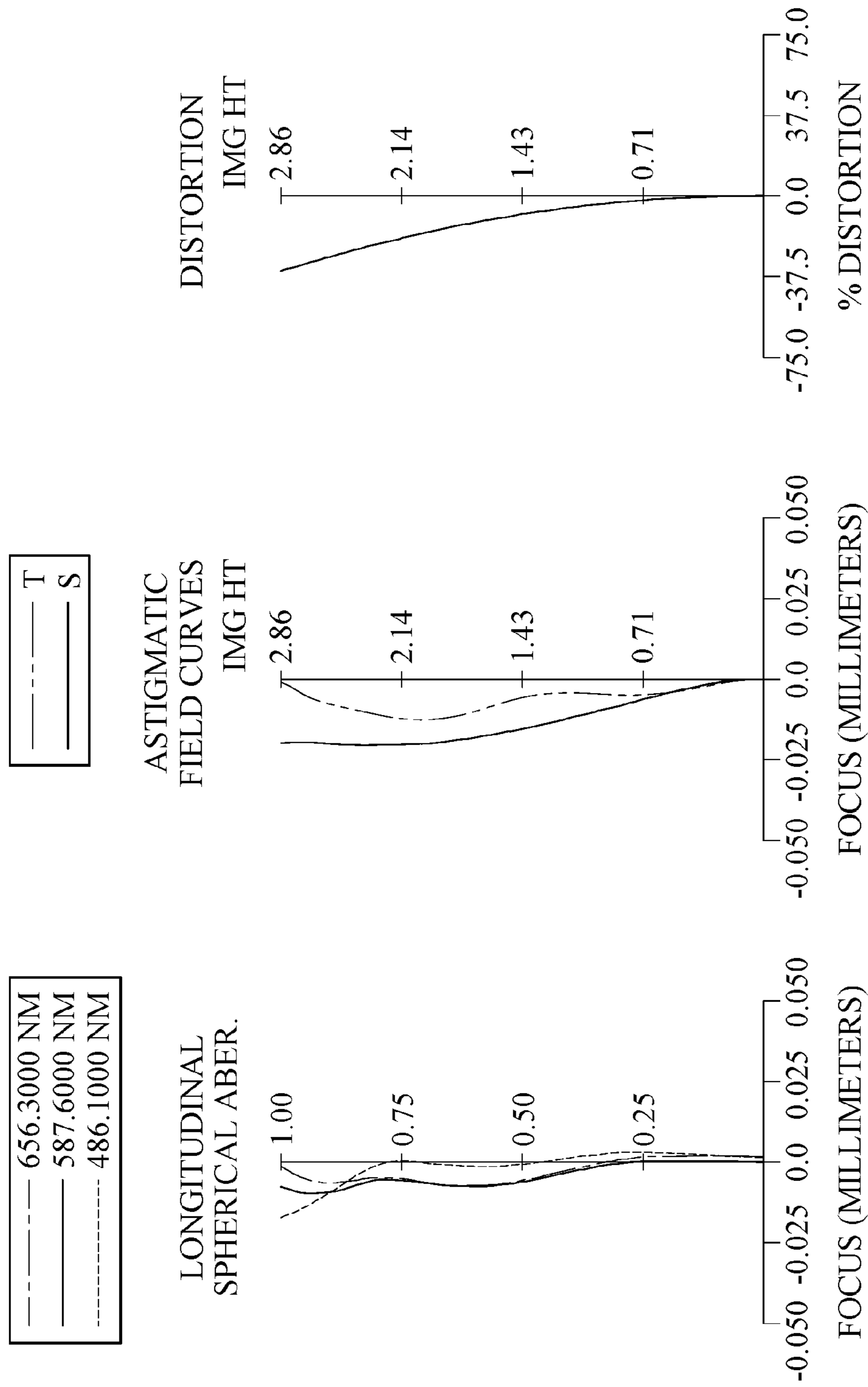

FIG.8

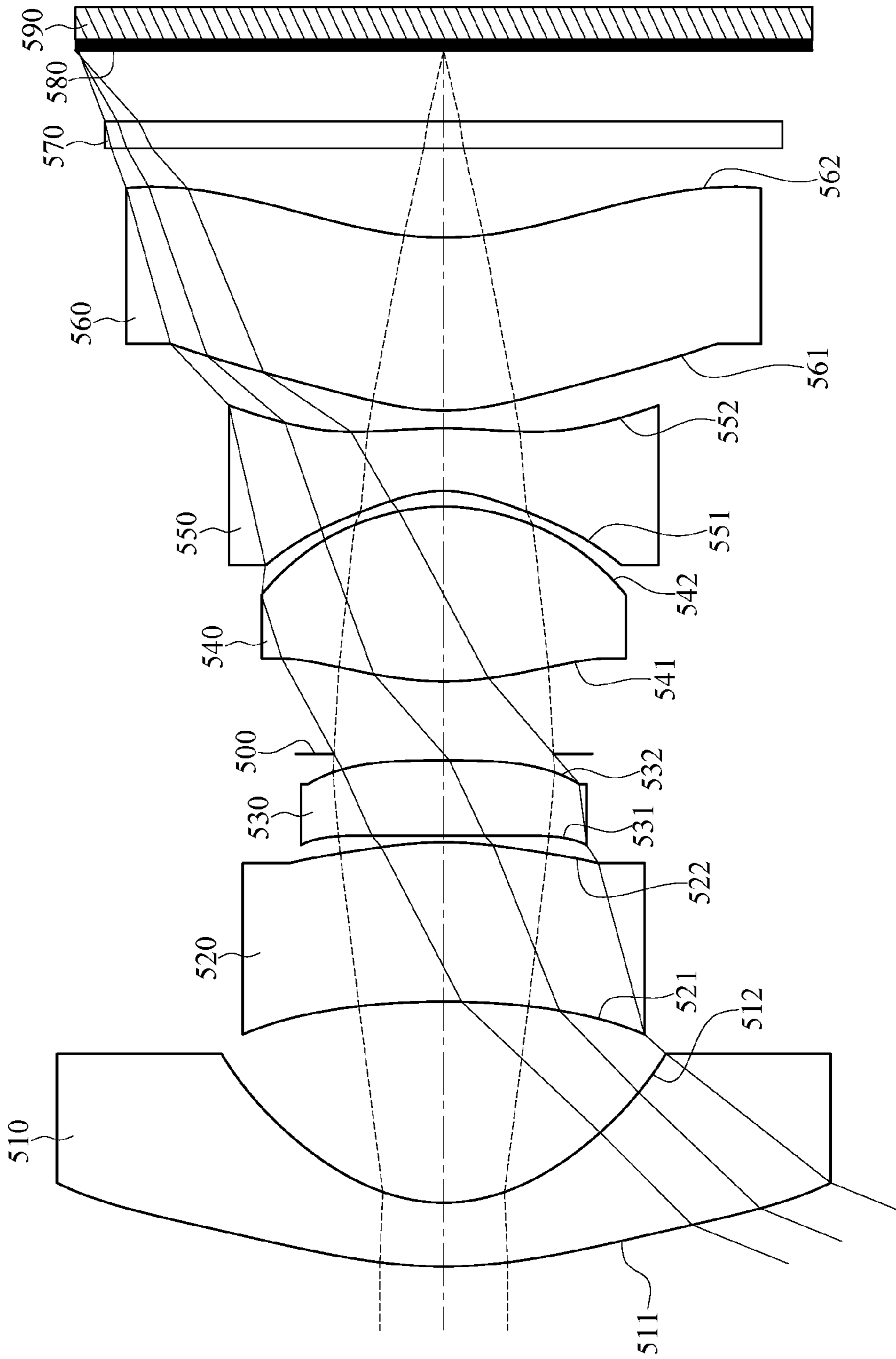

FIG.9

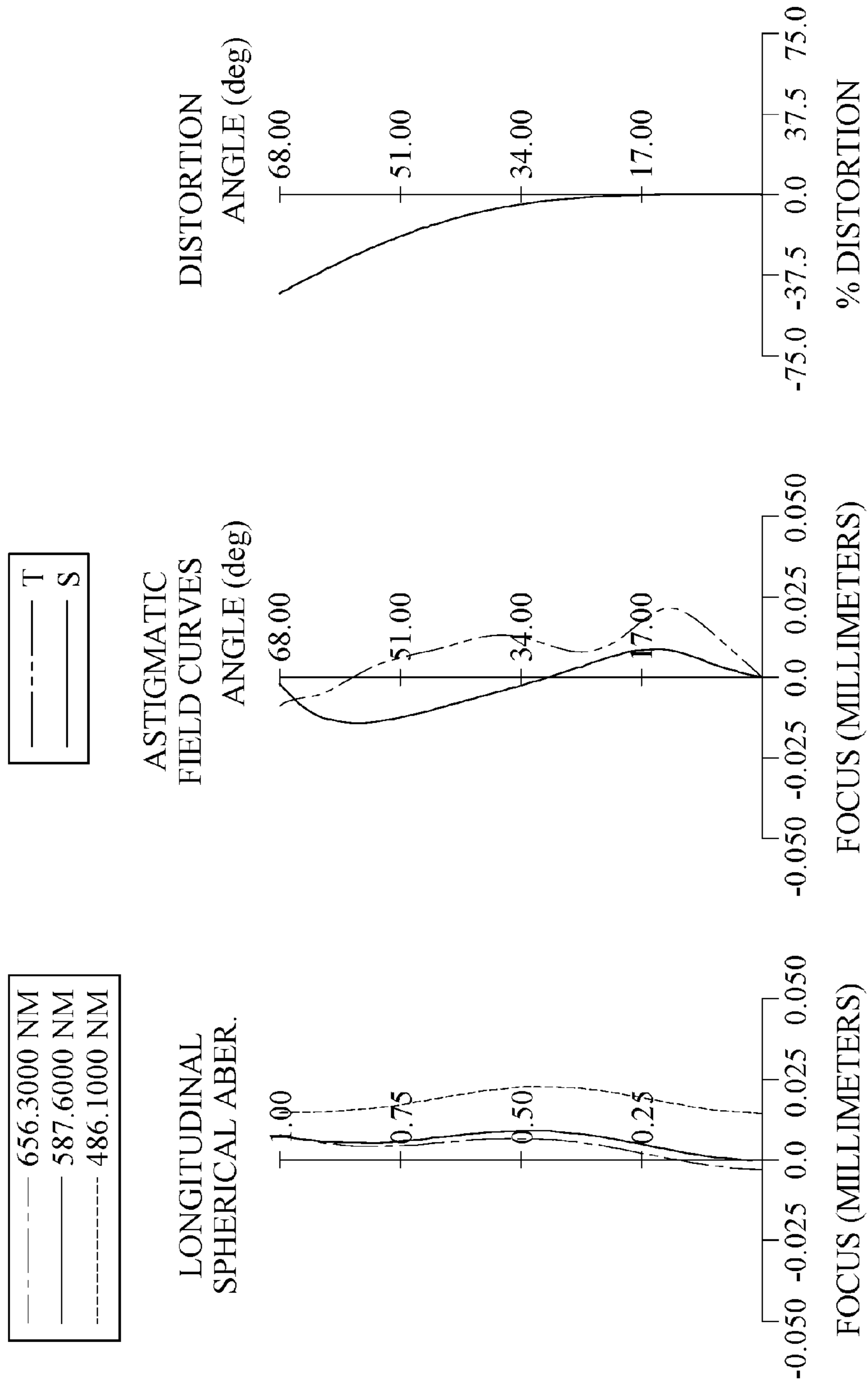

FIG.10

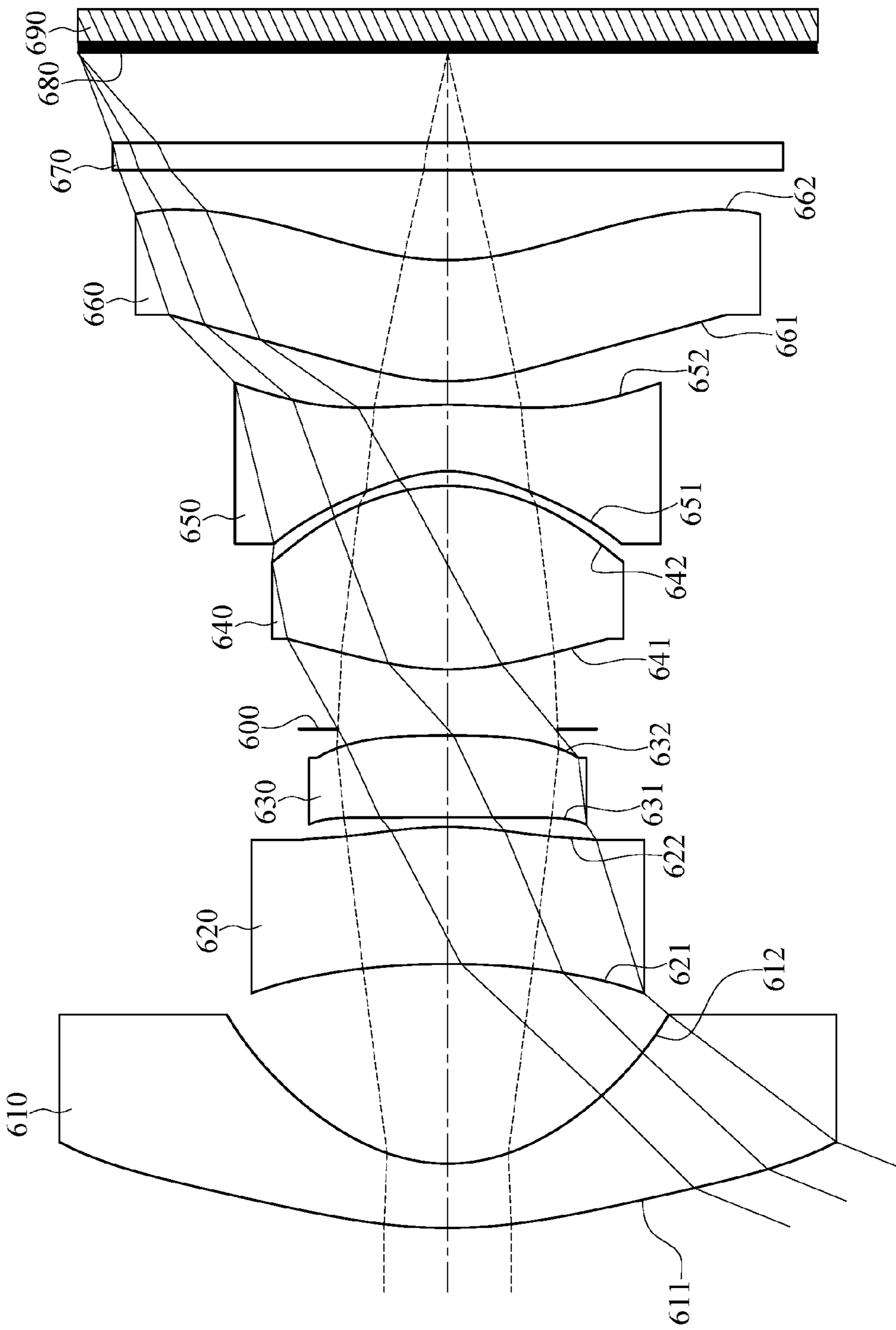

FIG.11

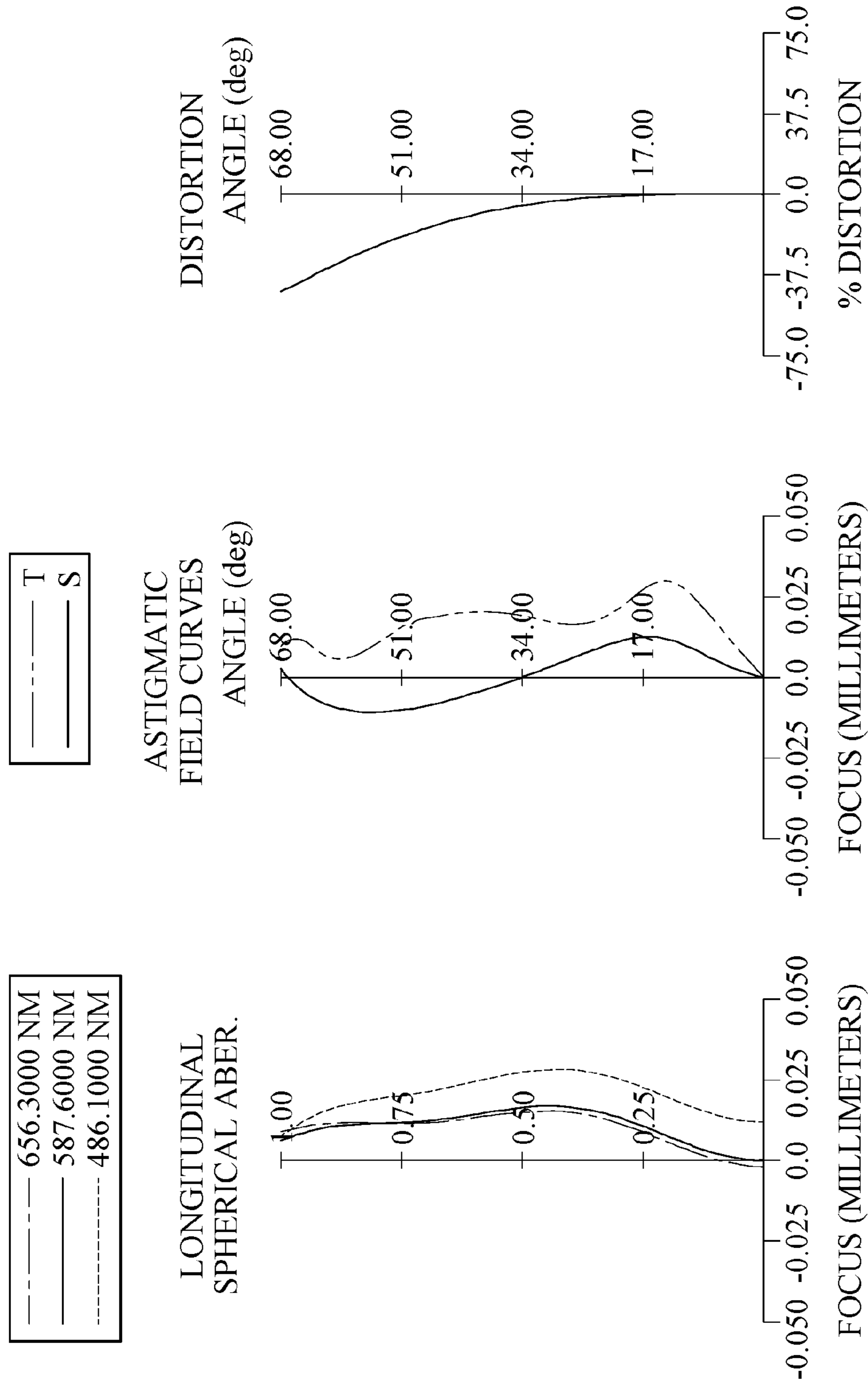

FIG.12

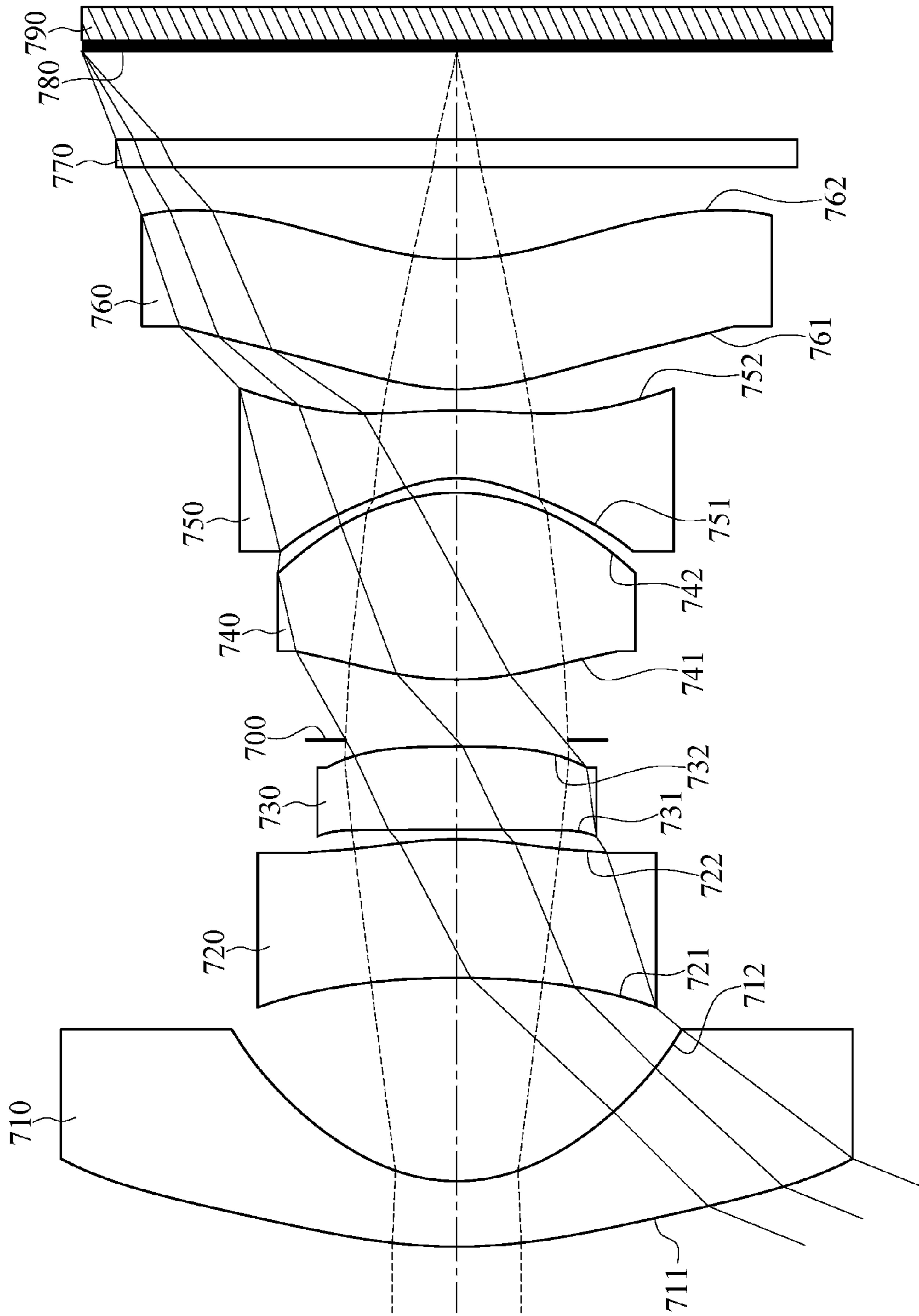

FIG.13

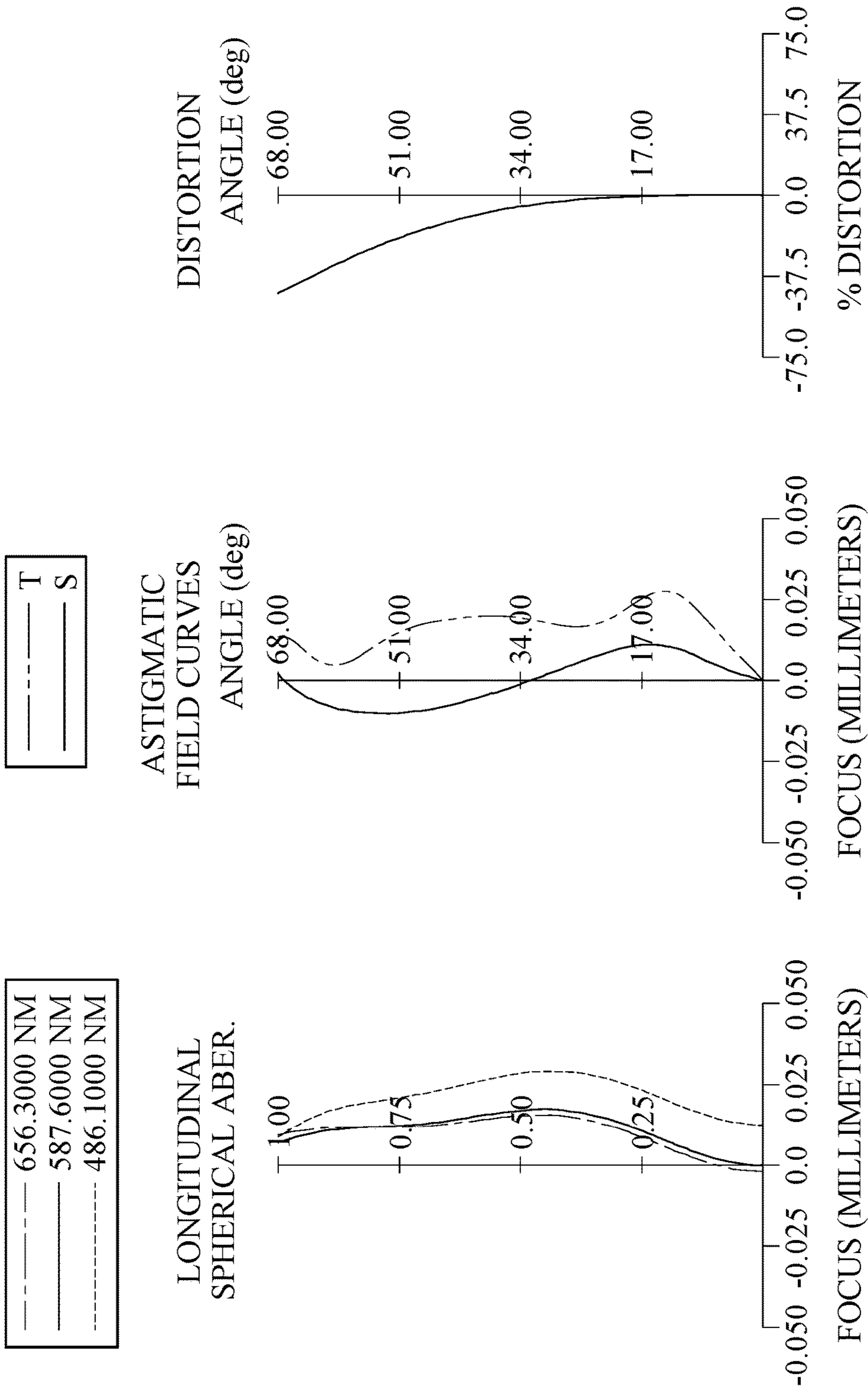

FIG.14

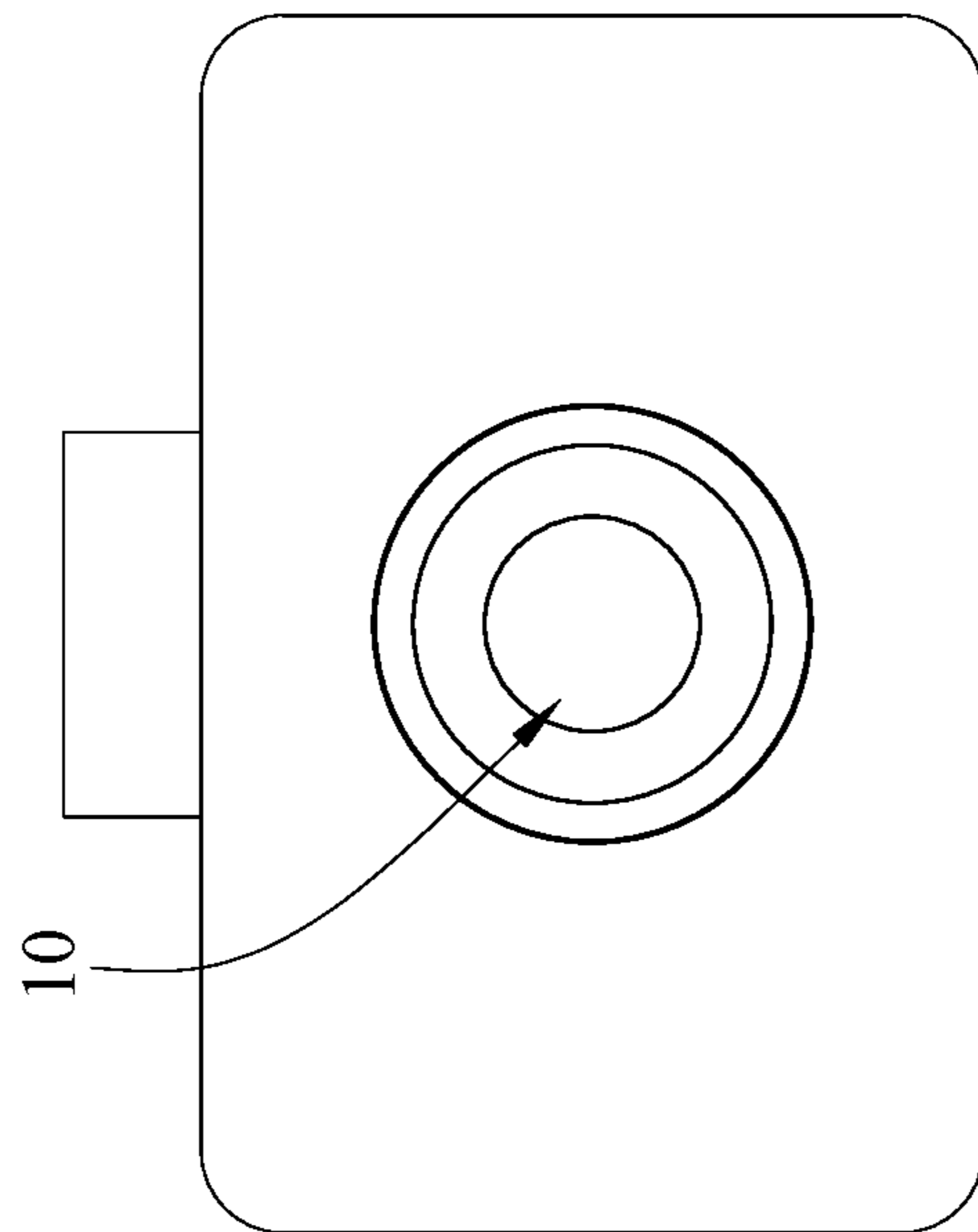

FIG. 15



1

**IMAGE CAPTURING LENS ASSEMBLY,  
IMAGE CAPTURING DEVICE AND  
VEHICLE PHOTOGRAPHING TERMINAL**

RELATED APPLICATIONS

This application is a continuation patent application of U.S. application Ser. No. 15/439,936, filed Feb. 22, 2017, which is a continuation patent application of U.S. application Ser. No. 14/196,621, filed Mar. 4, 2014, which claims priority to Taiwan Application Serial Number 103101848, filed Jan. 17, 2014, which is incorporated by reference herein in its entirety.

BACKGROUND

Technical Field

The present disclosure relates to an image capturing lens assembly, an image capturing device and a vehicle photographing terminal. More particularly, the present disclosure relates to a compact image capturing lens assembly and an image capturing device applicable to a vehicle photographing terminal.

Description of Related Art

In recent years, vehicle recording cameras, such as dash-cams are becoming more and more popular. The vehicle recording cameras enable drivers to provide video evidence from when they get involved in an accident. Furthermore, the rear-view cameras enable drivers to reverse their vehicles easier and avoid accidents.

A conventional optical system employed in a vehicle recording camera mainly adopts a structure with five or less lens elements. However, the conventional optical systems are not favorable for resolving power. Moreover, the surface shape of the lens elements and arrangement of refractive powers are also not favorable for correcting image distortion in a peripheral region and sufficient illumination. As a result, since the vehicle recording cameras focus on the image quality, the conventional optical system cannot satisfy this requirement.

SUMMARY

According to one aspect of the present disclosure, an image capturing lens assembly includes, in order from an object side to an image side, a first lens element, a second lens element, a third lens element, a fourth lens element, a fifth lens element, and a sixth lens element. The first lens element with negative refractive power has an image-side surface being concave in a paraxial region thereof. The second lens element has refractive power. The third lens element has refractive power. The fourth lens element has positive refractive power, wherein an object-side surface and an image-side surface of the fourth lens element are aspheric, and the fourth lens element is made of plastic material. The fifth lens element with negative refractive power has an object-side surface being concave in a paraxial region thereof, wherein both of the object-side surface and an image-side surface of the fifth lens element are aspheric. The sixth lens element with refractive power has an object-side surface being convex in a paraxial region thereof and an image-side surface being concave in a paraxial region thereof, wherein the image-side surface of the sixth lens element has at least one inflection point in an off-axis region

2

thereof, and both of an object-side surface and the image-side surface of the sixth lens element are aspheric. The image capturing lens assembly has a total of six lens elements with refractive power. At least three lens elements among the first through the sixth lens elements of the image capturing lens assembly are made of plastic material.

According to another aspect of the present disclosure, an image capturing device includes the image capturing lens assembly according to the aforementioned aspect and an image sensor.

According to still another aspect of the present disclosure, a vehicle photographing terminal includes the image capturing device according to the aforementioned aspect.

According to yet another aspect of the present disclosure, an image capturing lens assembly includes, in order from an object side to an image side, a first lens element, a second lens element, a third lens element, a fourth lens element, a fifth lens element, and a sixth lens element. The first lens element with negative refractive power has an image-side surface being concave in a paraxial region thereof. The second lens element with refractive power has an image-side surface being convex in a paraxial region thereof. The third lens element has refractive power. The fourth lens element has positive refractive power. The fifth lens element with negative refractive power has an object-side surface being concave in a paraxial region thereof, wherein both of the object-side surface and an image-side surface of the fifth lens element are aspheric. The sixth lens element with refractive power has an object-side surface being convex in a paraxial region thereof and an image-side surface being concave in a paraxial region thereof, wherein both of the image-side surface of the sixth lens element has at least one inflection point in an off-axis region thereof, and an object-side surface and the image-side surface of the sixth lens element are aspheric. The image capturing lens assembly has a total of six lens elements with refractive power. When a focal length of the image capturing lens assembly is  $f$ , and a curvature radius of the image-side surface of the sixth lens element is  $R_{12}$ , the following condition is satisfied:

$$0.25 < f/R_{12} < 1.25.$$

According to still yet another aspect of the present disclosure, an image capturing device includes the image capturing lens assembly according to the foregoing aspect and an image sensor.

According to a further aspect of the present disclosure, a vehicle photographing terminal includes the image capturing device according to the foregoing aspect.

BRIEF DESCRIPTION OF THE DRAWINGS

The disclosure can be more fully understood by reading the following detailed description of the embodiments, with reference made to the accompanying drawings as follows:

FIG. 1 is a schematic view of an image capturing device according to the 1st embodiment of the present disclosure;

FIG. 2 shows spherical aberration curves, astigmatic field curves and a distortion curve of the image capturing device according to the 1st embodiment;

FIG. 3 is a schematic view of an image capturing device according to the 2nd embodiment of the present disclosure;

FIG. 4 shows spherical aberration curves, astigmatic field curves and a distortion curve of the image capturing device according to the 2nd embodiment;

FIG. 5 is a schematic view of an image capturing device according to the 3rd embodiment of the present disclosure;

FIG. 6 shows spherical aberration curves, astigmatic field curves and a distortion curve of the image capturing device according to the 3rd embodiment;

FIG. 7 is a schematic view of an image capturing device according to the 4th embodiment of the present disclosure;

FIG. 8 shows spherical aberration curves, astigmatic field curves and a distortion curve of the image capturing device according to the 4th embodiment;

FIG. 9 is a schematic view of an image capturing device according to the 5th embodiment of the present disclosure;

FIG. 10 shows spherical aberration curves, astigmatic field curves and a distortion curve of the image capturing device according to the 5th embodiment;

FIG. 11 is a schematic view of an image capturing device according to the 6th embodiment of the present disclosure;

FIG. 12 shows spherical aberration curves, astigmatic field curves and a distortion curve of the image capturing device according to the 6th embodiment;

FIG. 13 is a schematic view of an image capturing device according to the 7th embodiment of the present disclosure;

FIG. 14 shows spherical aberration curves, astigmatic field curves and a distortion curve of the image capturing device according to the 7th embodiment; and

FIG. 15 shows a vehicle photographing terminal according to the 1st embodiment.

#### DETAILED DESCRIPTION

An image capturing lens assembly includes, in order from an object side to an image side, a first lens element, a second lens element, a third lens element, a fourth lens element, a fifth lens element, and a sixth lens element. The image capturing lens assembly has a total of six lens elements with refractive power.

The first lens element has negative refractive power, so that it is favorable for enlarging the field of view to capture more of the image scene. The first lens element can have an object-side surface being convex in a paraxial region thereof and an image-side surface being concave in a paraxial region thereof, so that it is favorable for reducing the astigmatism.

The second lens element can have an object-side surface being concave in a paraxial region thereof and an image-side surface being convex in a paraxial region thereof. Therefore, it is favorable for correcting the astigmatism.

The fourth lens element has positive refractive power. Therefore, it is favorable for reducing spherical aberration.

The fifth lens element with negative refractive power can have an object-side surface being concave in a paraxial region thereof and an image-side surface being convex in a paraxial region thereof. Therefore, it is favorable for improving the resolving power. Moreover, the image-side surface of the fifth lens element can have at least one inflection point in an off-axis region thereof; therefore, it is favorable for effectively reducing the incident angle of the off-axis on the image plane so as to improve the responding efficiency of the image sensor.

The sixth lens element can have an object-side surface being convex in a paraxial region thereof and an image-side surface being concave in a paraxial region thereof. Therefore, it is favorable for the principal point being positioned away from the image plane so as to reduce the total track length of the image capturing lens assembly. In addition, the image-side surface of the sixth lens element has at least one inflection point in an off-axis region thereof, so that it is favorable for correcting the image distortion in a peripheral region thereof and improving the relative illumination.

When a focal length of the image capturing lens assembly is  $f$ , and a curvature radius of the image-side surface of the sixth lens element is  $R12$ , the following condition is satisfied:  $0.25 < f/R12 < 1.25$ . Therefore, it is favorable for reducing the back focal length of the image capturing lens assembly.

When a focal length of the first lens element is  $f1$ , and a curvature radius of the object-side surface of the second lens element is  $R3$ , the following condition is satisfied:  $|f1/R3| < 1.4$ . Therefore, it is favorable for improving the illumination.

When a focal length of the second lens element is  $f2$ , and a focal length of the third lens element is  $f3$ , the following condition is satisfied:  $|f2/f3| < 2.0$ . Therefore, it is favorable for balancing the refractive powers of the second and the third lens elements so as to correct the aberration.

When a maximal field of view of the image capturing lens assembly is  $FOV$ , the following condition is satisfied:  $120 \text{ deg.} \leq FOV < 200 \text{ deg.}$  Therefore, the image capturing lens assembly can have larger field of view so as to obtain more of the image scene.

When the focal length of the first lens element is  $f1$ , the focal length of the second lens element is  $f2$ , and the focal length of the third lens element is  $f3$ , the following condition is satisfied:  $|f1/f2| + |f1/f3| < 1.0$ . Therefore, it is favorable for balancing the refractive powers of the image capturing lens assembly.

When an axial distance between the image-side surface of the sixth lens element and an image plane is  $BL$ , and the focal length of the image capturing lens assembly is  $f$ , the following condition is satisfied:  $BL/f < 1.0$ . Therefore, it is favorable for maintaining a proper back focal length.

When a curvature radius of the object-side surface of the sixth lens element is  $R11$ , and the curvature radius of the image-side surface of the sixth lens element is  $R12$ , the following condition is satisfied:  $-0.40 < (R11 - R12)/(R11 + R12) < 0.40$ . Therefore, it is favorable for effectively correcting the astigmatism.

According to the image capturing lens assembly of the present disclosure, the lens elements thereof can be made of glass or plastic material. When the lens elements are made of glass material, the distribution of the refractive power of the image capturing lens assembly may be more flexible to design. When the lens elements are made of plastic material, the manufacturing cost can be effectively reduced. Furthermore, surfaces of each lens element can be arranged to be aspheric, since the aspheric surface of the lens element is easy to form a shape other than spherical surface so as to have more controllable variables for eliminating the aberration thereof, and to further decrease the required number of the lens elements. Therefore, the total track length of the image capturing lens assembly can also be reduced.

According to the image capturing lens assembly of the present disclosure, each of an object-side surface and an image-side surface has a paraxial region and an off-axis region. The paraxial region refers to the region of the surface where light rays travel close to the optical axis, and the off-axis region refers to the region of the surface where light rays travel away from the optical axis. Particularly, when the lens element has a convex surface, it indicates that the surface is convex in the paraxial region thereof; when the lens element has a concave surface, it indicates that the surface is concave in the paraxial region thereof.

According to the image capturing lens assembly of the present disclosure, the image capturing lens assembly can include at least one stop, such as an aperture stop, a glare

## 5

stop or a field stop. Said glare stop or said field stop is for eliminating the stray light and thereby improving the image resolution thereof.

According to the image capturing lens assembly of the present disclosure, an aperture stop is configured as a middle stop. The middle stop disposed between the first lens element and the image plane is favorable for enlarging the field of view of the image capturing lens assembly and thereby provides a wider field of view for the same.

According to the present disclosure, an image capturing device is provided. The image capturing device includes the image capturing lens assembly according to the aforementioned image capturing lens assembly of the present disclosure, and an image sensor, wherein the image sensor is disposed on or near an image plane of the aforementioned image capturing lens assembly. In some embodiments, the image capturing device can further include a barrel member, a holding member or a combination thereof.

In FIG. 15, an image capturing device 10 may be installed in but not limited to a vehicle photographing terminal. In some embodiments, the vehicle photographing terminal can further include, but not limited to, display, a control unit, a random access memory unit (RAM), a read only memory unit (ROM) or a combination thereof.

According to the above description of the present disclosure, the following specific embodiments are provided for further explanation.

## 1st Embodiment

FIG. 1 is a schematic view of an image capturing device according to the 1st embodiment of the present disclosure. FIG. 2 shows, in order from left to right, spherical aberration curves, astigmatic field curves and a distortion curve of the image capturing device according to the 1st embodiment. In FIG. 1, the image capturing device includes the image capturing lens assembly (not otherwise herein labeled) of the present disclosure and an image sensor 190. The image capturing lens assembly includes, in order from an object side to an image side, a first lens element 110, a second lens element 120, a third lens element 130, an aperture stop 100, a fourth lens element 140, a fifth lens element 150, a sixth lens element 160, an IR-cut filter 170 and an image plane 180, wherein the image capturing lens assembly has a total of six lens elements (110-160) with refractive power.

The first lens element 110 with negative refractive power has an object-side surface 111 being convex in a paraxial region thereof and an image-side surface 112 being concave in a paraxial region thereof. The first lens element 110 is made of glass material.

The second lens element 120 with positive refractive power has an object-side surface 121 being concave in a paraxial region thereof and an image-side surface 122 being convex in a paraxial region thereof. The second lens element 120 is made of plastic material and has the object-side surface 121 and the image-side surface 122 being both aspheric.

The third lens element 130 with positive refractive power has an object-side surface 131 being concave in a paraxial region thereof and an image-side surface 132 being convex in a paraxial region thereof. The third lens element 130 is made of plastic material and has the object-side surface 131 and the image-side surface 132 being both aspheric.

The fourth lens element 140 with positive refractive power has an object-side surface 141 being convex in a paraxial region thereof and an image-side surface 142 being convex in a paraxial region thereof. The fourth lens element

## 6

140 is made of plastic material and has the object-side surface 141 and the image-side surface 142 being both aspheric.

The fifth lens element 150 with negative refractive power has an object-side surface 151 being concave in a paraxial region thereof and an image-side surface 152 being convex in a paraxial region thereof, wherein the image-side surface 152 of the fifth lens element 150 has at least one inflection point in an off-axis region thereof. The fifth lens element 150 is made of plastic material and has the object-side surface 151 and the image-side surface 152 being both aspheric.

The sixth lens element 160 with positive refractive power has an object-side surface 161 being convex in a paraxial region thereof and an image-side surface 162 being concave in a paraxial region thereof, wherein the image-side surface 162 of the sixth lens element 160 has at least one inflection point in an off-axis region thereof. The sixth lens element 160 is made of plastic material and has the object-side surface 161 and the image-side surface 162 being both aspheric.

The IR-cut filter 170 is made of glass and located between the sixth lens element 160 and the image plane 180, and will not affect the focal length of the image capturing lens assembly. The image sensor 190 is disposed on or near the image plane 180 of the image capturing lens assembly.

The equation of the aspheric surface profiles of the aforementioned lens elements of the 1st embodiment is expressed as follows:

$$X(Y) = (Y^2/R)/(1 + \text{sqrt}(1 - (1+k) \times (Y/R)^2)) + \sum_i (A_i) \times (Y^i),$$

where,

X is the relative distance between a point on the aspheric surface spaced at a distance Y from the optical axis and the tangential plane at the aspheric surface vertex on the optical axis;

Y is the vertical distance from the point on the aspheric surface to the optical axis;

R is the curvature radius;

k is the conic coefficient; and

A<sub>i</sub> is the i-th aspheric coefficient, and in the embodiments, i may be, but is not limited to, 4, 6, 8, 10, 12, 14 and 16.

In the image capturing lens assembly of the image capturing device according to the 1st embodiment, when a focal length of the image capturing lens assembly is f, an f-number of the image capturing lens assembly is F<sub>no</sub>, and half of a maximal field of view of the image capturing lens assembly is HFOV, these parameters have the following values: f=2.00 mm; F<sub>no</sub>=2.35; and HFOV=70.0 degrees.

In the image capturing lens assembly of the image capturing device according to the 1st embodiment, when a curvature radius of the object-side surface 161 of the sixth lens element 160 is R<sub>11</sub>, and a curvature radius of the image-side surface 162 of the sixth lens element 160 is R<sub>12</sub>, the following condition is satisfied: (R<sub>11</sub>-R<sub>12</sub>)/(R<sub>11</sub>+R<sub>12</sub>)=-0.17.

In the image capturing lens assembly of the image capturing device according to the 1st embodiment, when a focal length of the first lens element 110 is f<sub>1</sub>, and a curvature radius of the object-side surface 121 of the second lens element 120 is R<sub>3</sub>, the following condition is satisfied: |f<sub>1</sub>/R<sub>3</sub>|=0.47.

In the image capturing lens assembly of the image capturing device according to the 1st embodiment, when the

7

focal length of the image capturing lens assembly is  $f$ , and the curvature radius of the image-side surface **162** of the sixth lens element **160** is  $R_{12}$ , the following condition is satisfied:  $f/R_{12}=0.72$ .

In the image capturing lens assembly of the image capturing device according to the 1st embodiment, when a focal length of the second lens element **120** is  $f_2$ , and a focal length of the third lens element **130** is  $f_3$ , the following condition is satisfied:  $|f_2/f_3|=0.01$ .

In the image capturing lens assembly of the image capturing device according to the 1st embodiment, when the focal length of the first lens element **110** is  $f_1$ , the focal length of the second lens element **120** is  $f_2$ , and the focal length of the third lens element **130** is  $f_3$ , the following condition is satisfied:  $|f_1/f_2|f_1/f_3|=0.37$ .

8

In the image capturing lens assembly of the image capturing device according to the 1st embodiment, when an axial distance between the image-side surface **162** of the sixth lens element **160** and an image plane **180** is  $BL$ , the focal length of the image capturing lens assembly is  $f$ , the following condition is satisfied:  $BL/f=0.58$ .

In the image capturing lens assembly of the image capturing device according to the 1st embodiment, when a maximal field of view of the image capturing lens assembly is  $FOV$ , the following condition is satisfied:  $FOV=140.0$  deg.

The detailed optical data of the 1st embodiment are shown in Table 1 and the aspheric surface data are shown in Table 2 below.

TABLE 1

1st Embodiment							
f = 2.00 mm, Fno = 2.35, HFOV = 70.0 deg.							
Surface #		Curvature Radius	Thickness	Material	Index	Abbe #	Focal Length
0	Object	Plano	Infinity				
1	Lens 1	21.315	0.711	Glass	1.729	54.5	-3.38
2		2.177	1.054				
3	Lens 2	-7.184 ASP	0.883	Plastic	1.639	23.5	9.25
4		-3.397 ASP	0.979				
5	Lens 3	-3.777 ASP	0.536	Plastic	1.544	55.9	628.92
6		-3.922 ASP	-0.050				
7	Ape. Stop	Plano	0.100				
8	Lens 4	1.688 ASP	1.345	Plastic	1.544	55.9	1.65
9		-1.386 ASP	0.081				
10	Lens 5	-1.210 ASP	0.500	Plastic	1.639	23.5	-2.16
11		-11.192 ASP	0.983				
12	Lens 6	1.970 ASP	0.719	Plastic	1.535	55.7	9.60
13		2.789 ASP	0.700				
14	IR-cut filter	Plano	0.210	Glass	1.517	64.2	—
15		Plano	0.251				
16	Image	Plano	—				

Note:

Reference wavelength is 587.6 nm (d-line).

TABLE 2

Aspheric Coefficients					
	Surface #				
	3	4	5	6	8
k =	1.2465E+01	-7.8328E+00	-4.1808E+01	-4.8973E+01	-4.3646E+00
A4 =	1.9368E-02	2.2497E-02	6.1905E-02	-1.2934E-01	-3.2897E-02
A6 =	-1.6045E-03	-6.9057E-03	-7.1909E-02	7.4991E-02	6.0571E-03
A8 =	1.4445E-03	6.3663E-03	4.0058E-02	-6.0827E-02	-2.9859E-02
A10 =	-6.0475E-04	-3.0587E-03	-1.8784E-02	1.9164E-02	-3.8829E-03
A12 =	6.3075E-05	5.6894E-04			
	Surface #				
	9	10	11	12	13
k =	-1.4911E-01	-5.0976E+00	-9.0000E+01	-3.3114E+00	-5.6256E-01
A4 =	2.0021E-01	6.3857E-03	8.4123E-02	-2.1577E-02	-9.0096E-03
A6 =	-3.1452E-01	-9.3978E-02	-3.8074E-02	-2.2588E-04	-1.1438E-02
A8 =	2.7449E-01	1.2185E-01	6.4078E-02	-5.9004E-03	6.6537E-04
A10 =	-1.1784E-01	-5.1583E-02	-4.3431E-02	1.8695E-03	4.9476E-04
A12 =	1.9077E-02	5.8238E-03	1.3424E-02	-1.5214E-04	-1.0071E-04
A14 =			-1.9061E-03		5.4656E-06

In Table 1, the curvature radius, the thickness and the focal length are shown in millimeters (mm). Surface numbers 0-16 represent the surfaces sequentially arranged from the object-side to the image-side along the optical axis. In Table 2, k represents the conic coefficient of the equation of the aspheric surface profiles. A4-A14 represent the aspheric coefficients ranging from the 4th order to the 14th order. The tables presented below for each embodiment are the corresponding schematic parameter and aberration curves, and the definitions of the tables are the same as Table 1 and Table 2 of the 1st embodiment. Therefore, an explanation in this regard will not be provided again.

## 2nd Embodiment

FIG. 3 is a schematic view of an image capturing device according to the 2nd embodiment of the present disclosure. FIG. 4 shows, in order from left to right, spherical aberration curves, astigmatic field curves and a distortion curve of the image capturing device according to the 2nd embodiment. In FIG. 3, the image capturing device includes the image capturing lens assembly (not otherwise herein labeled) of the present disclosure and an image sensor 290. The image capturing lens assembly includes, in order from an object side to an image side, a first lens element 210, a second lens element 220, a third lens element 230, an aperture stop 200, a fourth lens element 240, a fifth lens element 250, a sixth lens element 260, an IR-cut filter 270 and an image plane 280, wherein the image capturing lens assembly has a total of six lens elements (210-260) with refractive power.

The first lens element 210 with negative refractive power has an object-side surface 211 being convex in a paraxial region thereof and an image-side surface 212 being concave in a paraxial region thereof. The first lens element 210 is made of plastic material and has the object-side surface 211 and the image-side surface 212 being both aspheric.

The second lens element 220 with positive refractive power has an object-side surface 221 being concave in a paraxial region thereof and an image-side surface 222 being convex in a paraxial region thereof. The second lens element

220 is made of plastic material and has the object-side surface 221 and the image-side surface 222 being both aspheric.

The third lens element 230 with negative refractive power has an object-side surface 231 being concave in a paraxial region thereof and an image-side surface 232 being convex in a paraxial region thereof. The third lens element 230 is made of plastic material and has the object-side surface 231 and the image-side surface 232 being both aspheric.

The fourth lens element 240 with positive refractive power has an object-side surface 241 being convex in a paraxial region thereof and an image-side surface 242 being convex in a paraxial region thereof. The fourth lens element 240 is made of plastic material and has the object-side surface 241 and the image-side surface 242 being both aspheric.

The fifth lens element 250 with negative refractive power has an object-side surface 251 being concave in a paraxial region thereof and an image-side surface 252 being convex in a paraxial region thereof, wherein the image-side surface 252 of the fifth lens element 250 has at least one inflection point in an off-axis region thereof. The fifth lens element 250 is made of plastic material and has the object-side surface 251 and the image-side surface 252 being both aspheric.

The sixth lens element 260 with positive refractive power has an object-side surface 261 being convex in a paraxial region thereof and an image-side surface 262 being concave in a paraxial region thereof, wherein the image-side surface 262 of the sixth lens element 260 has at least one inflection point in an off-axis region thereof. The sixth lens element 260 is made of plastic material and has the object-side surface 261 and the image-side surface 262 being both aspheric.

The IR-cut filter 270 is made of glass and located between the sixth lens element 260 and the image plane 280, and will not affect the focal length of the image capturing lens assembly. The image sensor 290 is disposed on or near the image plane 280 of the image capturing lens assembly.

The detailed optical data of the 2nd embodiment are shown in Table 3 and the aspheric surface data are shown in Table 4 below.

TABLE 3

2nd Embodiment								
f = 2.00 mm, Fno = 2.60, HFOV = 74.5 deg.								
Surface #		Curvature Radius	Thickness	Material	Index	Abbe #	Focal Length	
0	Object	Plano	Infinity					
1	Lens 1	5.555 ASP	0.531	Plastic	1.544	55.9	-3.56	
2		1.389 ASP	1.442					
3	Lens 2	-6.708 ASP	1.465	Plastic	1.583	30.2	7.49	
4		-2.860 ASP	0.119					
5	Lens 3	-3.594 ASP	0.500	Plastic	1.514	56.8	-19.42	
6		-5.885 ASP	-0.016					
7	Ape. Stop	Plano	0.311					
8	Lens 4	1.617 ASP	1.448	Plastic	1.544	55.9	1.63	
9		-1.344 ASP	0.117					
10	Lens 5	-1.013 ASP	0.500	Plastic	1.633	23.4	-1.88	
11		-8.071 ASP	0.388					
12	Lens 6	1.863 ASP	0.742	Plastic	1.530	55.8	10.90	
13		2.370 ASP	0.700					
14	IR-cut filter	Plano	0.210	Glass	1.517	64.2	—	
15		Plano	0.644					
16	Image	Plano	—					

Note:

Reference wavelength is 587.6 nm (d-line).

TABLE 4

Aspheric Coefficients						
	Surface #					
	1	2	3	4	5	6
k =	-7.7577E-01	-8.6801E-01	1.6471E+01	-1.9829E+01	9.7295E+00	3.1884E+01
A4 =	-1.3883E-02	-1.6178E-03	-2.4691E-02	4.0184E-02	1.6805E-01	-2.0056E-01
A6 =	2.0332E-03	2.5925E-03	7.2677E-04	2.0455E-02	-1.3407E-01	1.8606E-01
A8 =	-1.3480E-04	-1.6205E-03	4.6834E-03	-6.9494E-02	3.7576E-04	-2.0516E-01
A10 =	4.1148E-06	9.0545E-04	-2.1671E-03	4.3068E-02	-1.0017E-02	9.9870E-02
A12 =			6.5808E-04	-1.0367E-02		
	Surface #					
	8	9	10	11	12	13
k =	-6.2878E+00	-4.1998E-01	-3.1155E+00	-8.7056E+01	-6.6540E+00	-6.7240E-01
A4 =	-9.5333E-03	8.8047E-02	6.0043E-02	1.1899E-01	-2.8162E-02	-7.1865E-02
A6 =	-5.0700E-03	-1.2879E-01	-1.3176E-01	-1.5316E-02	1.0667E-02	1.5406E-02
A8 =	-1.6515E-02	1.3813E-01	1.3817E-01	-7.8675E-03	-2.4630E-03	-2.7094E-03
A10 =	4.2845E-03	-7.1978E-02	-7.1680E-02	2.0965E-03	3.3846E-04	2.7280E-04
A12 =		1.4560E-02	1.4989E-02	1.3767E-04	-1.9380E-05	-8.1268E-06
A14 =				-5.0075E-05		-4.4909E-07

In the 2nd embodiment, the equation of the aspheric surface profiles of the aforementioned lens elements is the same as the equation of the 1st embodiment. Also, the definitions of these parameters shown in the following table are the same as those stated in the 1st embodiment with corresponding values for the 2nd embodiment, so an explanation in this regard will not be provided again.

Moreover, these parameters can be calculated from Table 3 and Table 4 as the following values and satisfy the following conditions:

2nd Embodiment			
f [mm]	2.00	f/R12	0.84
Fno	2.60	f2/f3	0.39
HFOV [deg.]	74.5	f1/f2  +  f1/f3	0.66
(R11 - R12)/(R11 + R12)	-0.12	BL/f	0.78
f1/R3	0.53	FOV [deg.]	149.0

### 3rd Embodiment

FIG. 5 is a schematic view of an image capturing device according to the 3rd embodiment of the present disclosure. FIG. 6 shows, in order from left to right, spherical aberration curves, astigmatic field curves and a distortion curve of the image capturing device according to the 3rd embodiment. In FIG. 5, the image capturing device includes the image capturing lens assembly (not otherwise herein labeled) of the present disclosure and an image sensor 390. The image capturing lens assembly includes, in order from an object side to an image side, a first lens element 310, a second lens element 320, an aperture stop 300, a third lens element 330, a fourth lens element 340, a fifth lens element 350, a sixth lens element 360, an IR-cut filter 370 and an image plane 380, wherein the image capturing lens assembly has a total of six lens elements (310-360) with refractive power.

The first lens element 310 with negative refractive power has an object-side surface 311 being convex in a paraxial region thereof and an image-side surface 312 being concave in a paraxial region thereof. The first lens element 310 is made of glass material and has the object-side surface 311 and the image-side surface 312 being both aspheric.

The second lens element 320 with positive refractive power has an object-side surface 321 being concave in a paraxial region thereof and an image-side surface 322 being convex in a paraxial region thereof. The second lens element 320 is made of plastic material and has the object-side surface 321 and the image-side surface 322 being both aspheric.

The third lens element 330 with positive refractive power has an object-side surface 331 being convex in a paraxial region thereof and an image-side surface 332 being convex in a paraxial region thereof. The third lens element 330 is made of plastic material and has the object-side surface 331 and the image-side surface 332 being both aspheric.

The fourth lens element 340 with positive refractive power has an object-side surface 341 being convex in a paraxial region thereof and an image-side surface 342 being convex in a paraxial region thereof. The fourth lens element 340 is made of plastic material and has the object-side surface 341 and the image-side surface 342 being both aspheric.

The fifth lens element 350 with negative refractive power has an object-side surface 351 being concave in a paraxial region thereof and an image-side surface 352 being convex in a paraxial region thereof, wherein the image-side surface 352 of the fifth lens element 350 has at least one inflection point in an off-axis region thereof. The fifth lens element 350 is made of plastic material and has the object-side surface 351 and the image-side surface 352 being both aspheric.

The sixth lens element 360 with negative refractive power has an object-side surface 361 being convex in a paraxial region thereof and an image-side surface 362 being concave in a paraxial region thereof, wherein the image-side surface 362 of the sixth lens element 360 has at least one inflection point in an off-axis region thereof. The sixth lens element 360 is made of plastic material and has the object-side surface 361 and the image-side surface 362 being both aspheric.

The IR-cut filter 370 is made of glass and located between the sixth lens element 360 and the image plane 380, and will not affect the focal length of the image capturing lens assembly. The image sensor 390 is disposed on or near the image plane 380 of the image capturing lens assembly.

The detailed optical data of the 3rd embodiment are shown in Table 5 and the aspheric surface data are shown in Table 6 below.

TABLE 5

3rd Embodiment								
f = 2.22 mm, Fno = 2.52, HFOV = 78.7 deg.								
Surface #		Curvature Radius	Thickness	Material	Index	Abbe #	Focal Length	
0	Object	Plano	Infinity					
1	Lens 1	7.134 ASP	0.504	Glass	1.669	55.4	-3.43	
2		1.687 ASP	1.158					
3	Lens 2	-7.610 ASP	1.599	Plastic	1.650	21.5	25.19	
4		-5.626 ASP	0.349					
5	Ape. Stop	Plano	-0.022					
6	Lens 3	78.955 ASP	0.689	Plastic	1.514	56.8	14.47	
7		-8.178 ASP	0.187					
8	Lens 4	1.514 ASP	1.348	Plastic	1.544	55.9	1.87	
9		-2.125 ASP	0.175					
10	Lens 5	-1.327 ASP	0.505	Plastic	1.650	21.5	-2.77	
11		-5.811 ASP	0.837					
12	Lens 6	11.596 ASP	0.522	Plastic	1.650	21.5	-14.63	
13		5.134 ASP	0.700					
14	IR-cut filter	Plano	0.300	Glass	1.517	64.2	—	
15		Plano	0.247					
16	Image	Plano	—					

Note:

Reference wavelength is 587.6 nm (d-line).

TABLE 6

Aspheric Coefficients						
	Surface #					
	1	2	3	4	6	7
k =	3.6543E+00	-5.9557E-01	2.4803E+01	-1.6965E+01	-9.0000E+01	4.9210E+01
A4 =	-1.1936E-02	2.0981E-03	-6.6917E-03	8.5881E-02	2.0341E-01	-4.7360E-02
A6 =	2.1178E-03	3.8376E-03	-1.1888E-02	-4.8740E-02	-1.6023E-01	5.8535E-02
A8 =	-1.8404E-04	-1.2241E-03	6.1963E-03	-1.0698E-02	7.4821E-02	-5.1932E-02
A10 =	5.8989E-06	9.8799E-04	-4.3079E-03	2.3491E-02	-2.5088E-02	1.6227E-02
A12 =			1.7057E-03	-7.6015E-03		
	Surface #					
	8	9	10	11	12	13
k =	-5.2270E+00	-3.6915E-01	-4.7911E+00	-8.4845E+01	9.2560E+00	3.4920E-01
A4 =	5.1327E-02	7.8629E-02	6.6634E-02	1.8221E-01	5.0486E-03	-2.3419E-02
A6 =	-3.1743E-02	-9.5932E-02	-1.3139E-01	-1.1593E-01	-1.3950E-02	2.1915E-03
A8 =	1.3493E-02	1.1811E-01	1.3973E-01	6.6352E-02	3.8247E-03	-1.6598E-03
A10 =	-5.0155E-03	-7.1368E-02	-7.8422E-02	-2.8394E-02	-6.4976E-04	4.6061E-04
A12 =		1.4560E-02	1.5472E-02	6.6218E-03	5.5001E-05	-6.3143E-05
A14 =				-6.1429E-04		2.9860E-06

In the 3rd embodiment, the equation of the aspheric surface profiles of the aforementioned lens elements is the same as the equation of the 1st embodiment. Also, the definitions of these parameters shown in the following table are the same as those stated in the 1st embodiment with corresponding values for the 3rd embodiment, so an explanation in this regard will not be provided again.

Moreover, these parameters can be calculated from Table 5 and Table 6 as the following values and satisfy the following conditions:

3rd Embodiment			
f [mm]	2.22	f/R12	0.43
Fno	2.52	f2/f3	1.74
HFOV [deg.]	78.7	f1/f2  +  f1/f3	0.37

-continued

3rd Embodiment			
(R11 - R12)/(R11 + R12)	0.39	BL/f	0.56
f1/R3	0.45	FOV [deg.]	157.4

4th Embodiment

FIG. 7 is a schematic view of an image capturing device according to the 4th embodiment of the present disclosure. FIG. 8 shows, in order from left to right, spherical aberration curves, astigmatic field curves and a distortion curve of the image capturing device according to the 4th embodiment. In FIG. 7, the image capturing device includes the image capturing lens assembly (not otherwise herein labeled) of the present disclosure and an image sensor 490. The image

capturing lens assembly includes, in order from an object side to an image side, a first lens element **410**, a second lens element **420**, an aperture stop **400**, a third lens element **430**, a fourth lens element **440**, a fifth lens element **450**, a sixth lens element **460**, an IR-cut filter **470** and an image plane **480**, wherein the image capturing lens assembly has a total of six lens elements (**410-460**) with refractive power.

The first lens element **410** with negative refractive power has an object-side surface **411** being convex in a paraxial region thereof and an image-side surface **412** being concave in a paraxial region thereof. The first lens element **410** is made of plastic material and has the object-side surface **411** and the image-side surface **412** being both aspheric.

The second lens element **420** with negative refractive power has an object-side surface **421** being concave in a paraxial region thereof and an image-side surface **422** being convex in a paraxial region thereof. The second lens element **420** is made of plastic material and has the object-side surface **421** and the image-side surface **422** being both aspheric.

The third lens element **430** with positive refractive power has an object-side surface **431** being convex in a paraxial region thereof and an image-side surface **432** being convex in a paraxial region thereof. The third lens element **430** is made of plastic material and has the object-side surface **431** and the image-side surface **432** being both aspheric.

The fourth lens element **440** with positive refractive power has an object-side surface **441** being convex in a paraxial region thereof and an image-side surface **442** being convex in a paraxial region thereof. The fourth lens element

**440** is made of plastic material and has the object-side surface **441** and the image-side surface **442** being both aspheric.

The fifth lens element **450** with negative refractive power has an object-side surface **451** being concave in a paraxial region thereof and an image-side surface **452** being concave in a paraxial region thereof. The fifth lens element **450** is made of plastic material and has the object-side surface **451** and the image-side surface **452** being both aspheric.

The sixth lens element **460** with negative refractive power has an object-side surface **461** being convex in a paraxial region thereof and an image-side surface **462** being concave in a paraxial region thereof, wherein the image-side surface **462** of the sixth lens element **460** has at least one inflection point in an off-axis region thereof. The sixth lens element **460** is made of plastic material and has the object-side surface **461** and the image-side surface **462** being both aspheric.

The IR-cut filter **470** is made of glass and located between the sixth lens element **460** and the image plane **480**, and will not affect the focal length of the image capturing lens assembly. The image sensor **490** is disposed on or near the image plane **480** of the image capturing lens assembly.

The detailed optical data of the 4th embodiment are shown in Table 7 and the aspheric surface data are shown in Table 8 below.

TABLE 7

4th Embodiment								
f = 2.62 mm, Fno = 2.18, HFOV = 60.0 deg.								
Surface #		Curvature Radius	Thickness	Material	Index	Abbe #	Focal Length	
0	Object	Plano	Infinity					
1	Lens 1	16.926 ASP	0.500	Plastic	1.544	55.9	-4.09	
2		1.947 ASP	1.140					
3	Lens 2	-6.517 ASP	1.093	Plastic	1.583	30.2	-52.38	
4		-8.796 ASP	0.543					
5	Ape. Stop	Plano	-0.121					
6	Lens 3	16.020 ASP	0.847	Plastic	1.514	56.8	7.35	
7		-4.852 ASP	0.181					
8	Lens 4	1.804 ASP	1.633	Plastic	1.535	55.7	2.00	
9		-1.794 ASP	0.100					
10	Lens 5	-1.660 ASP	0.577	Plastic	1.639	23.5	-2.26	
11		12.719 ASP	0.994					
12	Lens 6	4.729 ASP	0.500	Plastic	1.535	55.7	-78.16	
13		4.092 ASP	0.700					
14	IR-cut filter	Plano	0.300	Glass	1.517	64.2	—	
15		Plano	0.314					
16	Image	Plano	—					

Note:

Reference wavelength is 587.6 nm (d-line).

TABLE 8

Aspheric Coefficients						
Surface #						
	1	2	3	4	6	7
k =	3.1781E+01	-5.5346E-01	1.5086E+01	3.5181E+01	-1.3375E+01	-8.5290E+00
A4 =	-2.6871E-03	5.6973E-03	-1.5772E-02	6.5484E-02	1.1936E-01	-3.4830E-02
A6 =	9.0291E-04	5.9238E-03	-5.3223E-03	-1.9592E-02	-5.6605E-02	2.5030E-02



TABLE 8-continued

Aspheric Coefficients						
A8 =	-6.8419E-05	-2.3180E-03	-1.0750E-04	1.5949E-04	1.8850E-02	-1.5544E-02
A10 =	2.4278E-06	1.0503E-03	1.2261E-03	5.0469E-03	-2.1113E-03	5.0606E-03
A12 =			2.2388E-05	-6.6122E-04		
Surface #						
	8	9	10	11	12	13
k =	-5.2701E+00	-1.0016E+00	-2.9048E+00	5.2777E+01	-3.0592E+00	-3.2861E-01
A4 =	3.8909E-02	3.9892E-02	2.1157E-02	6.6896E-02	-9.0033E-03	-1.0548E-02
A6 =	-2.0929E-02	1.8879E-03	6.0705E-03	-1.1638E-02	-2.9750E-03	-4.7423E-03
A8 =	5.6810E-03	-1.4842E-02	-2.0013E-02	1.7110E-03	9.8032E-04	1.5248E-03
A10 =	-2.1688E-03	5.8922E-03	1.0509E-02	-5.1379E-04	-1.0397E-04	-2.5153E-04
A12 =		-7.1252E-04	-1.6234E-03	-2.8731E-05	4.2592E-06	2.2032E-05
A14 =				5.8597E-06		-8.6733E-07

In the 4th embodiment, the equation of the aspheric surface profiles of the aforementioned lens elements is the same as the equation of the 1st embodiment. Also, the definitions of these parameters shown in the following table are the same as those stated in the 1st embodiment with corresponding values for the 4th embodiment, so an explanation in this regard will not be provided again.

Moreover, these parameters can be calculated from Table 7 and Table 8 as the following values and satisfy the following conditions:

4th Embodiment			
f [mm]	2.62	f/R12	0.64
Fno	2.18	f2/f3	7.12
HFOV [deg.]	60.0	f1/f2  +  f1/f3	0.63
(R11 - R12)/(R11 + R12)	0.07	BL/f	0.50
f1/R3	0.63	FOV [deg.]	120.0

#### 5th Embodiment

FIG. 9 is a schematic view of an image capturing device according to the 5th embodiment of the present disclosure. FIG. 10 shows, in order from left to right, spherical aberration curves, astigmatic field curves and a distortion curve of the image capturing device according to the 5th embodiment. In FIG. 9, the image capturing device includes the image capturing lens assembly (not otherwise herein labeled) of the present disclosure and an image sensor 590. The image capturing lens assembly includes, in order from an object side to an image side, a first lens element 510, a second lens element 520, a third lens element 530, an aperture stop 500, a fourth lens element 540, a fifth lens element 550, a sixth lens element 560, an IR-cut filter 570 and an image plane 580, wherein the image capturing lens assembly has a total of six lens elements (510-560) with refractive power.

The first lens element 510 with negative refractive power has an object-side surface 511 being convex in a paraxial region thereof and an image-side surface 512 being concave in a paraxial region thereof. The first lens element 510 is made of plastic material and has the object-side surface 511 and the image-side surface 512 being both aspheric.

The second lens element 520 with positive refractive power has an object-side surface 521 being concave in a paraxial region thereof and an image-side surface 522 being convex in a paraxial region thereof. The second lens element

520 is made of plastic material and has the object-side surface 521 and the image-side surface 522 being both aspheric.

The third lens element 530 with positive refractive power has an object-side surface 531 being convex in a paraxial region thereof and an image-side surface 532 being convex in a paraxial region thereof. The third lens element 530 is made of plastic material and has the object-side surface 531 and the image-side surface 532 being both aspheric.

The fourth lens element 540 with positive refractive power has an object-side surface 541 being convex in a paraxial region thereof and an image-side surface 542 being convex in a paraxial region thereof. The fourth lens element 540 is made of plastic material and has the object-side surface 541 and the image-side surface 542 being both aspheric.

The fifth lens element 550 with negative refractive power has an object-side surface 551 being concave in a paraxial region thereof and an image-side surface 552 being convex in a paraxial region thereof, wherein the image-side surface 552 of the fifth lens element 550 has at least one inflection point in an off-axis region thereof. The fifth lens element 550 is made of plastic material and has the object-side surface 551 and the image-side surface 552 being both aspheric.

The sixth lens element 560 with positive refractive power has an object-side surface 561 being convex in a paraxial region thereof and an image-side surface 562 being concave in a paraxial region thereof, wherein the image-side surface 562 of the sixth lens element 560 has at least one inflection point in an off-axis region thereof. The sixth lens element 560 is made of plastic material and has the object-side surface 561 and the image-side surface 562 being both aspheric.

The IR-cut filter 570 is made of glass and located between the sixth lens element 560 and the image plane 580, and will not affect the focal length of the image capturing lens assembly. The image sensor 590 is disposed on or near the image plane 580 of the image capturing lens assembly.

The detailed optical data of the 5th embodiment are shown in Table 9 and the aspheric surface data are shown in Table 10 below.

TABLE 9

5th Embodiment								
f = 2.25 mm, Fno = 2.25, HFOV = 68.0 deg.								
Surface #		Curvature Radius	Thickness	Material	Index	Abbe #	Focal Length	
0	Object	Plano	Infinity					
1	Lens 1	3.800 ASP	0.499	Plastic	1.544	55.9	-4.12	
2		1.345 ASP	1.575					
3	Lens 2	-6.848 ASP	1.249	Plastic	1.544	55.9	8.06	
4		-2.846 ASP	0.050					
5	Lens 3	99.952 ASP	0.593	Plastic	1.544	55.9	21.62	
6		-13.306 ASP	0.050					
7	Ape. Stop	Plano	0.569					
8	Lens 4	2.459 ASP	1.369	Plastic	1.544	55.9	1.99	
9		-1.553 ASP	0.123					
10	Lens 5	-0.909 ASP	0.490	Plastic	1.639	23.5	-1.97	
11		-3.949 ASP	0.138					
12	Lens 6	1.641 ASP	1.356	Plastic	1.544	55.9	5.67	
13		2.486 ASP	0.700					
14	IR-cut filter	Plano	0.210	Glass	1.517	64.2	—	
15		Plano	0.558					
16	Image	Plano	—					

Note:

Reference wavelength is 587.6 nm (d-line).

TABLE 10

Aspheric Coefficients						
	Surface #					
	1	2	3	4	5	6
k =	-2.4314E+00	-1.1183E+00	1.4804E+01	-8.1278E+00	8.9746E+01	-8.2504E+00
A4 =	-1.4807E-02	1.4511E-03	-1.0604E-02	4.0736E-02	-2.0017E-03	-1.4892E-01
A6 =	1.7599E-03	1.7060E-04	3.5120E-03	4.3116E-03	1.5663E-02	7.4536E-02
A8 =	-9.2466E-05	-3.0768E-04	5.3774E-03	-1.4515E-02	-5.6815E-02	-5.2614E-02
A10 =	2.8155E-06	3.9328E-04	-4.5017E-03	-5.3073E-03	1.1118E-02	1.2909E-02
A12 =			9.9542E-04	4.5075E-03		
	Surface #					
	8	9	10	11	12	13
k =	-2.2294E+00	-1.0900E-01	-4.2979E+00	-6.6229E+01	-9.0267E+00	-7.9390E-01
A4 =	-5.6894E-02	1.5754E-01	1.1384E-01	6.1422E-02	-2.2492E-02	-4.4313E-02
A6 =	1.4329E-02	-1.9914E-01	-1.5171E-01	4.7859E-02	1.0902E-02	6.1163E-03
A8 =	-4.1339E-03	1.3779E-01	7.9451E-02	-5.7413E-02	-2.4831E-03	-6.3199E-04
A10 =	-8.7771E-04	-4.6576E-02	-2.4850E-02	2.3395E-02	2.9720E-04	3.0339E-05
A12 =		6.6309E-03	3.6514E-03	-4.4683E-03	-1.4676E-05	-5.4258E-07
A14 =				3.3824E-04		

In the 5th embodiment, the equation of the aspheric surface profiles of the aforementioned lens elements is the same as the equation of the 1st embodiment. Also, the definitions of these parameters shown in the following table are the same as those stated in the 1st embodiment with corresponding values for the 5th embodiment, so an explanation in this regard will not be provided again.

Moreover, these parameters can be calculated from Table 9 and Table 10 as the following values and satisfy the following conditions:

5th Embodiment			
f [mm]	2.25	f/R12	0.91
Fno	2.25	f2/f3	0.37
HFOV [deg.]	68.0	f1/f2  +  f1/f3	0.70

-continued

5th Embodiment			
(R11 - R12)/(R11 + R12)	-0.20	BL/f	0.65
f1/R3	0.60	FOV [deg.]	136.0

6th Embodiment

FIG. 11 is a schematic view of an image capturing device according to the 6th embodiment of the present disclosure. FIG. 12 shows, in order from left to right, spherical aberration curves, astigmatic field curves and a distortion curve of the image capturing device according to the 6th embodiment. In FIG. 11, the image capturing device includes the image capturing lens assembly (not otherwise herein labeled) of the present disclosure and an image sensor 690. The image capturing lens assembly includes, in order from

## 21

an object side to an image side, a first lens element **610**, a second lens element **620**, a third lens element **630**, an aperture stop **600**, a fourth lens element **640**, a fifth lens element **650**, a sixth lens element **660**, an IR-cut filter **670** and an image plane **680**, wherein the image capturing lens assembly has a total of six lens elements (**610-660**) with refractive power.

The first lens element **610** with negative refractive power has an object-side surface **611** being convex in a paraxial region thereof and an image-side surface **612** being concave in a paraxial region thereof. The first lens element **610** is made of plastic material and has the object-side surface **611** and the image-side surface **612** being both aspheric.

The second lens element **620** with positive refractive power has an object-side surface **621** being concave in a paraxial region thereof and an image-side surface **622** being convex in a paraxial region thereof. The second lens element **620** is made of plastic material and has the object-side surface **621** and the image-side surface **622** being both aspheric.

The third lens element **630** with positive refractive power has an object-side surface **631** being concave in a paraxial region thereof and an image-side surface **632** being convex in a paraxial region thereof. The third lens element **630** is made of plastic material and has the object-side surface **631** and the image-side surface **632** being both aspheric.

The fourth lens element **640** with positive refractive power has an object-side surface **641** being convex in a paraxial region thereof and an image-side surface **642** being

## 22

convex in a paraxial region thereof. The fourth lens element **640** is made of plastic material and has the object-side surface **641** and the image-side surface **642** being both aspheric.

The fifth lens element **650** with negative refractive power has an object-side surface **651** being concave in a paraxial region thereof and an image-side surface **652** being convex in a paraxial region thereof, wherein the image-side surface **652** of the fifth lens element **650** has at least one inflection point in an off-axis region thereof. The fifth lens element **650** is made of plastic material and has the object-side surface **651** and the image-side surface **652** being both aspheric.

The sixth lens element **660** with positive refractive power has an object-side surface **661** being convex in a paraxial region thereof and an image-side surface **662** being concave in a paraxial region thereof, wherein the image-side surface **662** of the sixth lens element **660** has at least one inflection point in an off-axis region thereof. The sixth lens element **660** is made of plastic material and has the object-side surface **661** and the image-side surface **662** being both aspheric.

The IR-cut filter **670** is made of glass and located between the sixth lens element **660** and the image plane **680**, and will not affect the focal length of the image capturing lens assembly. The image sensor **690** is disposed on or near the image plane **680** of the image capturing lens assembly.

The detailed optical data of the 6th embodiment are shown in Table 11 and the aspheric surface data are shown in Table 12 below.

TABLE 11

6th Embodiment						
f = 2.23 mm, Fno = 2.25, HFOV = 68.0 deg.						
Surface #		Curvature Radius	Thickness	Material	Index	Abbe # Focal Length
0	Object	Plano	Infinity			
1	Lens 1	3.964 ASP	0.500	Plastic	1.544	55.9
2		1.349 ASP	1.552			
3	Lens 2	-6.510 ASP	1.066	Plastic	1.544	55.9
4		-2.665 ASP	0.073			7.55
5	Lens 3	-23.087 ASP	0.636	Plastic	1.544	55.9
6		-14.852 ASP	0.050			74.49
7	Ape. Stop	Plano	0.465			
8	Lens 4	2.128 ASP	1.427	Plastic	1.544	55.9
9		-1.382 ASP	0.112			1.80
10	Lens 5	-0.938 ASP	0.517	Plastic	1.639	23.5
11		-4.114 ASP	0.182			-2.03
12	Lens 6	1.679 ASP	0.942	Plastic	1.544	55.9
13		2.045 ASP	0.700			9.04
14	IR-cut filter	Plano	0.210	Glass	1.517	64.2
15		Plano	0.701			—
16	Image	Plano	—			

Note:

Reference wavelength is 587.6 nm (d-line).

TABLE 12

Aspheric Coefficients						
Surface #						
	1	2	3	4	5	6
k =	-2.4122E+00	-1.0225E+00	1.3646E+01	-1.9346E+01	9.0000E+01	3.5043E+00
A4 =	-1.4391E-02	-4.2764E-04	-1.2139E-02	2.4650E-02	5.8564E-02	-1.7485E-01
A6 =	1.8315E-03	-1.0859E-04	1.2893E-02	4.3529E-02	-5.5538E-02	9.4379E-02
A8 =	-1.0190E-04	1.3977E-04	-1.6490E-04	-2.2641E-02	2.0821E-02	-6.1852E-02

TABLE 12-continued

Aspheric Coefficients						
A10 =	3.1981E-06	3.1764E-04	-3.2449E-03	-8.2732E-03	-2.8051E-02	1.2957E-02
A12 =			9.4406E-04	3.2519E-03		
Surface #						
	8	9	10	11	12	13
k =	-4.0863E+00	-3.4664E-01	-4.3222E+00	-9.0000E+01	-6.3261E+00	-9.2125E-01
A4 =	-4.5156E-02	2.2507E-01	1.3411E-01	8.3562E-02	-3.0249E-02	-6.8034E-02
A6 =	2.4513E-02	-3.2405E-01	-2.7412E-01	-1.0229E-02	1.0609E-02	1.3298E-02
A8 =	-1.6226E-02	2.7268E-01	2.2601E-01	-7.3332E-03	-2.0104E-03	-1.9930E-03
A10 =	5.4363E-03	-1.1237E-01	-9.4576E-02	2.6046E-03	2.3100E-04	1.4142E-04
A12 =		1.9077E-02	1.5551E-02	-2.2014E-04	-1.2958E-05	2.1779E-06
A14 =				-5.5074E-06		-7.2184E-07

In the 6th embodiment, the equation of the aspheric surface profiles of the aforementioned lens elements is the same as the equation of the 1st embodiment. Also, the definitions of these parameters shown in the following table are the same as those stated in the 1st embodiment with corresponding values for the 6th embodiment, so an explanation in this regard will not be provided again.

Moreover, these parameters can be calculated from Table 11 and Table 12 as the following values and satisfy the following conditions:

6th Embodiment			
f [mm]	2.23	f/R12	1.09
Fno	2.25	f2/f3	0.10
HFOV [deg.]	68.0	f1/f2  +  f1/f3	0.59
(R11 - R12)/(R11 + R12)	-0.10	BL/f	0.72
f1/R3	0.62	FOV [deg.]	136.0

#### 7th Embodiment

FIG. 13 is a schematic view of an image capturing device according to the 7th embodiment of the present disclosure. FIG. 14 shows, in order from left to right, spherical aberration curves, astigmatic field curves and a distortion curve of the image capturing device according to the 7th embodiment. In FIG. 13, the image capturing device includes the image capturing lens assembly (not otherwise herein labeled) of the present disclosure and an image sensor 790. The image capturing lens assembly includes, in order from an object side to an image side, a first lens element 710, a second lens element 720, a third lens element 730, an aperture stop 700, a fourth lens element 740, a fifth lens element 750, a sixth lens element 760, an IR-cut filter 770 and an image plane 780, wherein the image capturing lens assembly has a total of six lens elements (710-760) with refractive power.

The first lens element 710 with negative refractive power has an object-side surface 711 being convex in a paraxial region thereof and an image-side surface 712 being concave in a paraxial region thereof. The first lens element 710 is made of plastic material and has the object-side surface 711 and the image-side surface 712 being both aspheric.

The second lens element 720 with positive refractive power has an object-side surface 721 being concave in a

paraxial region thereof and an image-side surface 722 being convex in a paraxial region thereof. The second lens element 720 is made of plastic material and has the object-side surface 721 and the image-side surface 722 being both aspheric.

The third lens element 730 with positive refractive power has an object-side surface 731 being concave in a paraxial region thereof and an image-side surface 732 being convex in a paraxial region thereof. The third lens element 730 is made of plastic material and has the object-side surface 731 and the image-side surface 732 being both aspheric.

The fourth lens element 740 with positive refractive power has an object-side surface 741 being convex in a paraxial region thereof and an image-side surface 742 being convex in a paraxial region thereof. The fourth lens element 740 is made of plastic material and has the object-side surface 741 and the image-side surface 742 being both aspheric.

The fifth lens element 750 with negative refractive power has an object-side surface 751 being concave in a paraxial region thereof and an image-side surface 752 being convex in a paraxial region thereof, wherein the image-side surface 752 of the fifth lens element 750 has at least one inflection point in an off-axis region thereof. The fifth lens element 750 is made of plastic material and has the object-side surface 751 and the image-side surface 752 being both aspheric.

The sixth lens element 760 with positive refractive power has an object-side surface 761 being convex in a paraxial region thereof and an image-side surface 762 being concave in a paraxial region thereof, wherein the image-side surface 762 of the sixth lens element 760 has at least one inflection point in an off-axis region thereof. The sixth lens element 760 is made of plastic material and has the object-side surface 761 and the image-side surface 762 being both aspheric.

The IR-cut filter 770 is made of glass and located between the sixth lens element 760 and the image plane 780, and will not affect the focal length of the image capturing lens assembly. The image sensor 790 is disposed on or near the image plane 780 of the image capturing lens assembly.

The detailed optical data of the 7th embodiment are shown in Table 13 and the aspheric surface data are shown in Table 14 below.

TABLE 13

7th Embodiment								
f = 2.21 mm, Fno = 2.25, HFOV = 68.0 deg.								
Surface #		Curvature Radius	Thickness	Material	Index	Abbe #	Focal Length	
0	Object	Plano	Infinity					
1	Lens 1	3.963 ASP	0.500	Plastic	1.544	55.9	-4.00	
2		1.344 ASP	1.552					
3	Lens 2	-6.496 ASP	1.058	Plastic	1.544	55.9	7.52	
4		-2.654 ASP	0.073					
5	Lens 3	-24.361 ASP	0.633	Plastic	1.544	55.9	73.89	
6		-15.308 ASP	0.050					
7	Ape. Stop	Plano	0.460					
8	Lens 4	2.147 ASP	1.428	Plastic	1.544	55.9	1.79	
9		-1.369 ASP	0.110					
10	Lens 5	-0.936 ASP	0.516	Plastic	1.639	23.5	-2.02	
11		-4.153 ASP	0.162					
12	Lens 6	1.692 ASP	0.994	Plastic	1.544	55.9	8.63	
13		2.098 ASP	0.700					
14	IR-cut filter	Plano	0.210	Glass	1.517	64.2	—	
15		Plano	0.675					
16	Image	Plano	—					

Note:

Reference wavelength is 587.6 nm (d-line).

TABLE 14

Aspheric Coefficients						
	Surface #					
	1	2	3	4	5	6
k =	-2.4546E+00	-1.0121E+00	1.3690E+01	-1.9040E+01	9.0000E+01	3.9791E+01
A4 =	-1.4409E-02	-1.1117E-03	-1.2694E-02	2.2879E-02	5.4782E-02	-1.7665E-01
A6 =	1.8446E-03	-1.9845E-04	1.2869E-02	4.2861E-02	-5.5494E-02	9.4757E-02
A8 =	-1.0159E-04	6.2529E-05	-1.1552E-04	-2.1746E-02	2.1319E-02	-6.1702E-02
A10 =	3.1436E-06	3.4355E-04	-3.2092E-03	-8.2990E-03	-2.8898E-02	1.2806E-02
A12 =			9.4406E-04	3.2519E-03		
	Surface #					
	8	9	10	11	12	13
k =	-4.4477E+00	-3.2573E-01	-4.3284E+00	-9.0000E+01	-6.7515E+00	-4.7054E-01
A4 =	-4.4958E-02	2.2563E-01	1.3537E-01	8.3238E-02	-2.9054E-02	-7.0056E-02
A6 =	2.2503E-02	-3.2332E-01	-2.7364E-01	-1.0167E-02	9.0793E-03	1.0528E-02
A8 =	-1.5988E-02	2.7322E-01	2.2612E-01	-7.3216E-03	-1.4399E-03	-1.2904E-03
A10 =	5.1532E-03	-1.1284E-01	-9.4986E-02	2.5926E-03	1.3600E-04	-9.9499E-06
A12 =		1.9077E-02	1.5551E-02	-2.2014E-04	-6.6936E-06	1.9083E-05
A14 =				-5.5074E-06		-1.5949E-06

In the 7th embodiment, the equation of the aspheric surface profiles of the aforementioned lens elements is the same as the equation of the 1st embodiment. Also, the definitions of these parameters shown in the following table are the same as those stated in the 1st embodiment with corresponding values for the 7th embodiment, so an explanation in this regard will not be provided again.

Moreover, these parameters can be calculated from Table 13 and Table 14 as the following values and satisfy the following conditions:

7th Embodiment			
f [mm]	2.21	f/R12	1.05
Fno	2.25	f2/f3	0.10
HFOV [deg.]	68.0	f1/f2  +  f1/f3	0.59

-continued

7th Embodiment			
(R11 - R12)/(R11 + R12)	-0.11	BL/f	0.72
f1/R3	0.62	FOV [deg.]	136.0

The foregoing image capturing device **10** may be installed in but not limited to a vehicle photographing terminal, including vehicle recording cameras or rear-view cameras. Moreover, according to the present disclosure, the fifth lens element has negative refractive power, the sixth lens element has an object-side surface being convex in a paraxial region thereof and an image-side surface being concave in a paraxial region thereof, and the image-side surface of the sixth lens element has at least one inflection point in an off-axis region thereof. Accordingly, it is favorable for correcting the image distortion in a peripheral region and

improving relative illumination and resolving power for the vehicle photographing terminal and the image capturing device **10**.

The foregoing description, for purpose of explanation, has been described with reference to specific embodiments. It is to be noted that TABLES 1-14 show different data of the different embodiments; however, the data of the different embodiments are obtained from experiments. The embodiments were chosen and described in order to best explain the principles of the disclosure and its practical applications, to thereby enable others skilled in the art to best utilize the disclosure and various embodiments with various modifications as are suited to the particular use contemplated. The embodiments depicted above and the appended drawings are exemplary and are not intended to be exhaustive or to limit the scope of the present disclosure to the precise forms disclosed. Many modifications and variations are possible in view of the above teachings.

What is claimed is:

**1.** An image capturing lens assembly comprising six lens elements, the six lens elements being, in order from an object side to an image side:

a first lens element with negative refractive power having an image-side surface being concave in a paraxial region thereof;

a second lens element having an image-side surface being convex in a paraxial region thereof, wherein an absolute value of a curvature radius of an object-side surface of the second lens element is larger than an absolute value of a curvature radius of the image-side surface of the second lens element;

a third lens element having negative refractive power;

a fourth lens element;

a fifth lens element having an object-side surface being aspheric, wherein an absolute value of a curvature radius of the object-side surface of the fifth lens element is smaller than an absolute value of a curvature radius of an image-side surface of the fifth lens element; and

a sixth lens element having an image-side surface being concave in a paraxial region thereof, wherein the image-side surface of the sixth lens element has at least one inflection point in an off-axis region thereof;

wherein an axial distance between the image-side surface of the sixth lens element and an image plane is  $BL$ , a focal length of the image capturing lens assembly is  $f$ , and the following condition is satisfied:

$$BL/f \leq 0.78.$$

**2.** The image capturing lens assembly of claim **1**, wherein the second lens element has positive refractive power.

**3.** The image capturing lens assembly of claim **1**, wherein the image-side surface of the fifth lens element is convex in a paraxial region thereof.

**4.** The image capturing lens assembly of claim **1**, wherein a maximal field of view of the image capturing lens assembly is  $FOV$ , and the following condition is satisfied:

$$120 \text{ deg.} \leq FOV < 200 \text{ deg.}$$

**5.** The image capturing lens assembly of claim **1**, wherein the sixth lens element has negative refractive power.

**6.** The image capturing lens assembly of claim **1**, wherein the sixth lens element has an object-side surface being convex in a paraxial region thereof.

**7.** The image capturing lens assembly of claim **1**, wherein a curvature radius of an object-side surface of the sixth lens

element is  $R11$ , a curvature radius of the image-side surface of the sixth lens element is  $R12$ , and the following condition is satisfied:

$$-0.40 < (R11 - R12) / (R11 + R12) < 0.40.$$

**8.** The image capturing lens assembly of claim **1**, wherein an absolute value of a curvature radius of an object-side surface of the first lens element is larger than an absolute value of a curvature radius of the image-side surface of the first lens element.

**9.** The image capturing lens assembly of claim **1**, wherein the focal length of the image capturing lens assembly is  $f$ , a curvature radius of the image-side surface of the sixth lens element is  $R12$ , and the following condition is satisfied:

$$0.25 < f/R12 < 1.25.$$

**10.** The image capturing lens assembly of claim **1**, wherein a focal length of the second lens element is  $f2$ , a focal length of the third lens element is  $f3$ , and the following condition is satisfied:

$$|f2/f3| < 2.0.$$

**11.** The image capturing lens assembly of claim **1**, wherein at least one of the object-side surface and the image-side surface of the fifth lens element has at least one inflection point in an off-axis region thereof.

**12.** The image capturing lens assembly of claim **1**, wherein an absolute value of a curvature radius of an object-side surface of the sixth lens element is larger than an absolute value of a curvature radius of the image-side surface of the sixth lens element.

**13.** The image capturing lens assembly of claim **1**, wherein the fourth lens element has an object-side surface being convex in a paraxial region thereof.

**14.** The image capturing lens assembly of claim **1**, wherein a focal length of the first lens element is  $f1$ , the curvature radius of the object-side surface of the second lens element is  $R3$ , and the following condition is satisfied:

$$|f1/R3| < 1.4.$$

**15.** The image capturing lens assembly of claim **1**, wherein at least three lens elements among the first through the sixth lens elements of the image capturing lens assembly are made of plastic material.

**16.** The image capturing lens assembly of claim **1**, wherein there is a gap in a paraxial region between every adjacent lens elements of the image capturing lens assembly.

**17.** The image capturing lens assembly of claim **1**, wherein the fourth lens element has an object-side surface and an image-side surface being both aspheric, and the image-side surface of the fifth lens element is aspheric.

**18.** An image capturing device, comprising:

the image capturing lens assembly of claim **1**; and

an image sensor, wherein the image sensor is located on or near the image plane of the image capturing lens assembly.

**19.** A vehicle photographing terminal, comprising:

the image capturing device of claim **18**.

**20.** An image capturing lens assembly comprising six lens elements, the six lens elements being, in order from an object side to an image side:

a first lens element with negative refractive power having an image-side surface being concave in a paraxial region thereof;

a second lens element having an image-side surface being convex in a paraxial region thereof, wherein an absolute value of a curvature radius of an object-side

29

surface of the second lens element is larger than an absolute value of a curvature radius of the image-side surface of the second lens element;  
 a third lens element;  
 a fourth lens element;  
 a fifth lens element having an object-side surface being aspheric, wherein an absolute value of a curvature radius of the object-side surface of the fifth lens element is smaller than an absolute value of a curvature radius of an image-side surface of the fifth lens element, and at least one of the object-side surface and the image-side surface of the fifth lens element has at least one inflection point in an off-axis region thereof; and  
 a sixth lens element having an image-side surface being concave in a paraxial region thereof, wherein the image-side surface of the sixth lens element has at least one inflection point in an off-axis region thereof;  
 wherein an axial distance between the image-side surface of the sixth lens element and an image plane is BL, a focal length of the image capturing lens assembly is f, and the following condition is satisfied:

$$BL/f \leq 0.78.$$

21. The image capturing lens assembly of claim 20, wherein the second lens element has positive refractive power.

22. The image capturing lens assembly of claim 20, wherein the image-side surface of the fifth lens element is convex in a paraxial region thereof.

23. The image capturing lens assembly of claim 20, wherein a maximal field of view of the image capturing lens assembly is FOV, and the following condition is satisfied:

$$120 \text{ deg.} \leq \text{FOV} < 200 \text{ deg.}$$

24. The image capturing lens assembly of claim 20, wherein the sixth lens element has negative refractive power.

25. The image capturing lens assembly of claim 20, wherein the sixth lens element has an object-side surface being convex in a paraxial region thereof.

26. The image capturing lens assembly of claim 20, wherein a curvature radius of an object-side surface of the sixth lens element is R11, a curvature radius of the image-side surface of the sixth lens element is R12, and the following condition is satisfied:

$$-0.40 < (R11 - R12) / (R11 + R12) < 0.40.$$

27. The image capturing lens assembly of claim 20, wherein an absolute value of a curvature radius of an object-side surface of the first lens element is larger than an

30

absolute value of a curvature radius of the image-side surface of the first lens element.

28. The image capturing lens assembly of claim 20, wherein the focal length of the image capturing lens assembly is f, a curvature radius of the image-side surface of the sixth lens element is R12, and the following condition is satisfied:

$$0.25 < f/R12 < 1.25.$$

29. The image capturing lens assembly of claim 20, wherein a focal length of the second lens element is f2, a focal length of the third lens element is f3, and the following condition is satisfied:

$$|f2/f3| < 2.0.$$

30. The image capturing lens assembly of claim 20, wherein an absolute value of a curvature radius of an object-side surface of the sixth lens element is larger than an absolute value of a curvature radius of the image-side surface of the sixth lens element.

31. The image capturing lens assembly of claim 20, wherein the fourth lens element has an object-side surface being convex in a paraxial region thereof.

32. The image capturing lens assembly of claim 20, wherein a focal length of the first lens element is f1, the curvature radius of the object-side surface of the second lens element is R3, and the following condition is satisfied:

$$|f1/R3| < 1.4.$$

33. The image capturing lens assembly of claim 20, wherein at least three lens elements among the first through the sixth lens elements of the image capturing lens assembly are made of plastic material.

34. The image capturing lens assembly of claim 20, wherein there is a gap in a paraxial region between every adjacent lens elements of the image capturing lens assembly.

35. The image capturing lens assembly of claim 20, wherein the fourth lens element has an object-side surface and an image-side surface being both aspheric, and the image-side surface of the fifth lens element is aspheric.

36. An image capturing device, comprising:  
 the image capturing lens assembly of claim 20; and  
 an image sensor, wherein the image sensor is located on or near the image plane of the image capturing lens assembly.

37. A vehicle photographing terminal, comprising:  
 the image capturing device of claim 36.

\* \* \* \* \*