



US010483248B2

(12) **United States Patent**
Yota et al.

(10) **Patent No.:** **US 10,483,248 B2**
(45) **Date of Patent:** **Nov. 19, 2019**

(54) **WAFER LEVEL CHIP SCALE FILTER PACKAGING USING SEMICONDUCTOR WAFERS WITH THROUGH WAFER VIAS**

(2013.01); *H01L 24/89* (2013.01); *H01L 41/0475* (2013.01); *H03H 3/02* (2013.01); *H03H 3/08* (2013.01); *H03H 9/0547* (2013.01); *H03H 9/1007* (2013.01); *H03H 9/1064* (2013.01); *H03H 9/64* (2013.01); *H01L 21/6835* (2013.01); *H01L 21/76898* (2013.01); *H01L 21/78* (2013.01); *H01L 23/66* (2013.01); *H01L 28/10* (2013.01); *H01L 28/40* (2013.01); *H01L 29/861* (2013.01); *H01L 41/1875* (2013.01);

(71) Applicant: **SKYWORKS SOLUTIONS, INC.**,
Woburn, MA (US)

(72) Inventors: **Jiro Yota**, Westlake Village, CA (US);
Hong Shen, Palo Alto, CA (US);
Viswanathan Ramanathan, Thousand Oaks, CA (US)

(73) Assignee: **SKYWORKS SOLUTIONS, INC.**,
Woburn, MA (US)

(*) Notice: Subject to any disclaimer, the term of this patent is extended or adjusted under 35 U.S.C. 154(b) by 0 days.

(21) Appl. No.: **15/912,924**

(22) Filed: **Mar. 6, 2018**

(65) **Prior Publication Data**
US 2018/0277527 A1 Sep. 27, 2018

Related U.S. Application Data

(60) Provisional application No. 62/475,386, filed on Mar. 23, 2017.

(51) **Int. Cl.**
H01L 25/16 (2006.01)
H01L 23/31 (2006.01)
(Continued)

(52) **U.S. Cl.**
CPC *H01L 25/16* (2013.01); *H01L 21/30604* (2013.01); *H01L 23/06* (2013.01); *H01L 23/3114* (2013.01); *H01L 23/3171* (2013.01); *H01L 23/481* (2013.01); *H01L 23/585* (2013.01); *H01L 24/05* (2013.01); *H01L 24/08*

(58) **Field of Classification Search**

CPC . *H01L 25/16*; *H01L 23/3114*; *H01L 23/3171*; *H01L 23/481*; *H01L 23/585*; *H01L 24/05*; *H01L 24/08*; *H01L 24/89*; *H01L 41/0475*; *H03H 3/02*; *H03H 3/08*; *H03H 9/0547*; *H03H 9/1007*; *H03H 9/1064*; *H03H 9/64*
See application file for complete search history.

(56) **References Cited**

U.S. PATENT DOCUMENTS

7,615,833 B2 * 11/2009 Larson, III *H03B 5/326*
257/416
7,732,991 B2 * 6/2010 Liu *B81B 3/0086*
310/328

(Continued)

Primary Examiner — Ida M Soward

(74) *Attorney, Agent, or Firm* — Lando & Anastasi, LLP

(57) **ABSTRACT**

An electronics package includes a semiconductor substrate having one or more passive devices formed thereon and a cavity defined in a first surface thereof. A piezoelectric substrate is bonded to the semiconductor substrate and has a radio frequency (RF) filter formed thereon. The RF filter is disposed within the cavity defined in the semiconductor substrate.

22 Claims, 30 Drawing Sheets

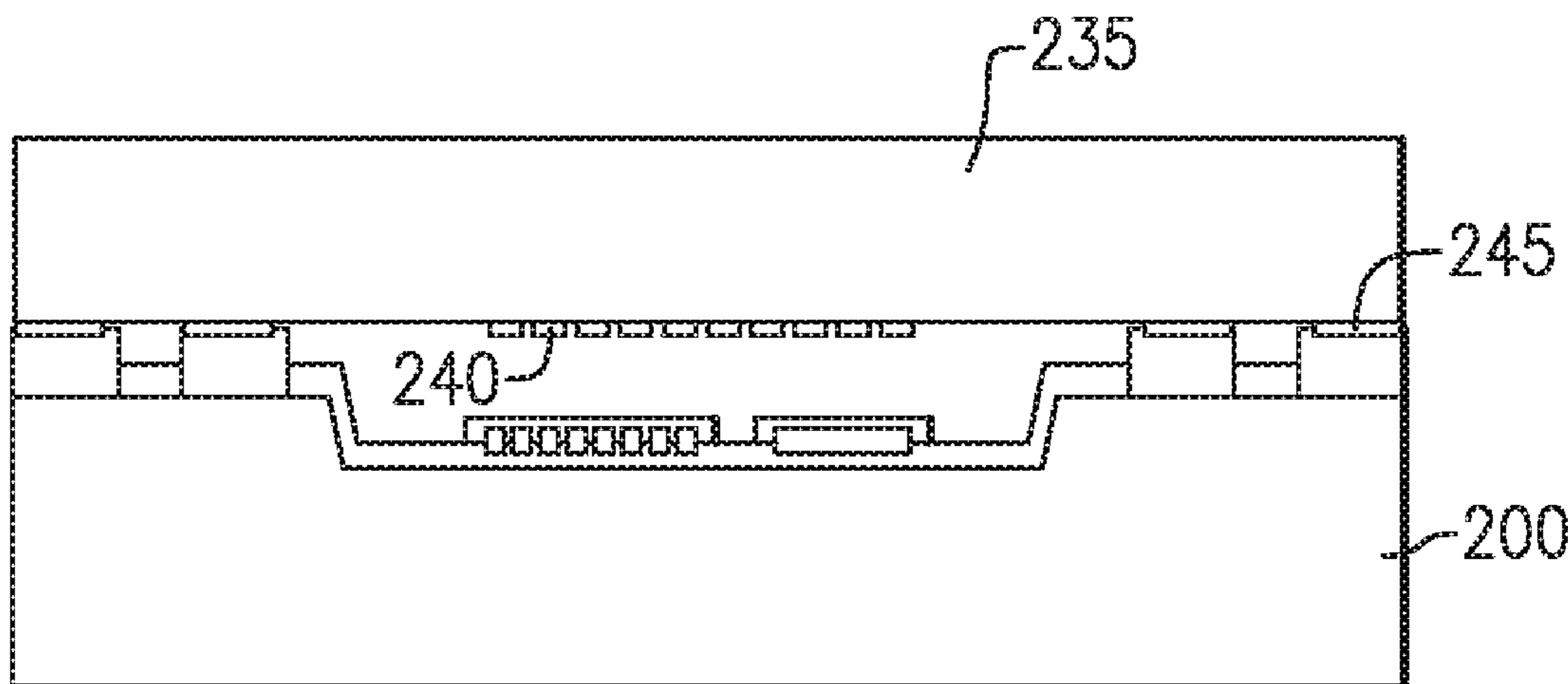

(51) **Int. Cl.**
H01L 23/48 (2006.01)
H01L 23/58 (2006.01)
H01L 41/04 (2006.01)
H03H 3/02 (2006.01)
H03H 9/05 (2006.01)
H03H 9/10 (2006.01)
H03H 9/64 (2006.01)
H01L 23/00 (2006.01)
H01L 41/047 (2006.01)
H01L 21/306 (2006.01)
H03H 3/08 (2006.01)
H01L 23/06 (2006.01)
H03H 9/02 (2006.01)
H01L 49/02 (2006.01)
H01L 23/66 (2006.01)
H01L 29/861 (2006.01)
H01L 41/187 (2006.01)
H01L 21/768 (2006.01)
H01L 21/78 (2006.01)
H01L 41/33 (2013.01)
H03H 9/00 (2006.01)
H01L 21/683 (2006.01)

(52) **U.S. Cl.**
 CPC *H01L 41/1876* (2013.01); *H01L 41/33*
 (2013.01); *H01L 2221/68327* (2013.01); *H01L*
2223/6627 (2013.01); *H01L 2224/08145*
 (2013.01); *H03H 9/0004* (2013.01); *H03H*
9/02559 (2013.01)

(56) **References Cited**

U.S. PATENT DOCUMENTS

9,058,455 B2 * 6/2015 Adkisson H03H 9/64
 9,395,533 B2 * 7/2016 Sasagawa G02B 26/02
 9,440,848 B2 * 9/2016 Sasagawa B81C 1/00801
 9,448,251 B2 * 9/2016 Liu G01P 15/0802
 10,020,789 B2 * 7/2018 Adkisson G06F 17/5063
 10,228,353 B2 * 3/2019 Rothberg B81C 1/00238
 2003/0060172 A1 * 3/2003 Kuriyama H04B 1/036
 455/575.1
 2008/0087530 A1 * 4/2008 Paranjpye H01H 1/0036
 200/181
 2009/0030291 A1 * 1/2009 O'Brien A61B 5/0031
 600/301
 2009/0224851 A1 * 9/2009 Feiertag H03H 9/059
 333/186
 2016/0037649 A1 2/2016 Barber
 2017/0163243 A1 * 6/2017 Bulger H03H 3/08
 2017/0214386 A1 * 7/2017 Kido H03H 9/25
 2018/0062618 A1 * 3/2018 Nagarkar H03H 3/02

* cited by examiner

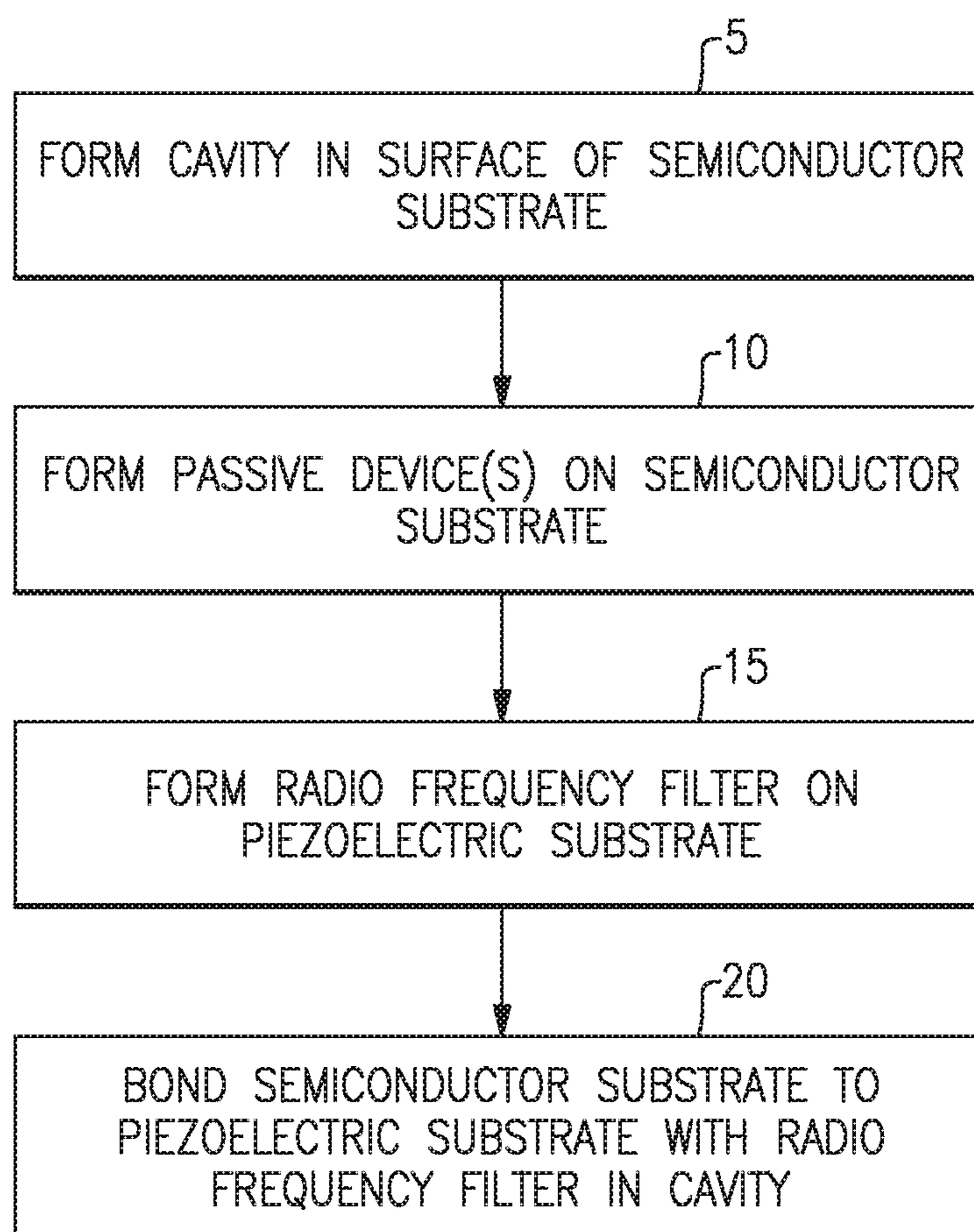
**FIG. 1A**

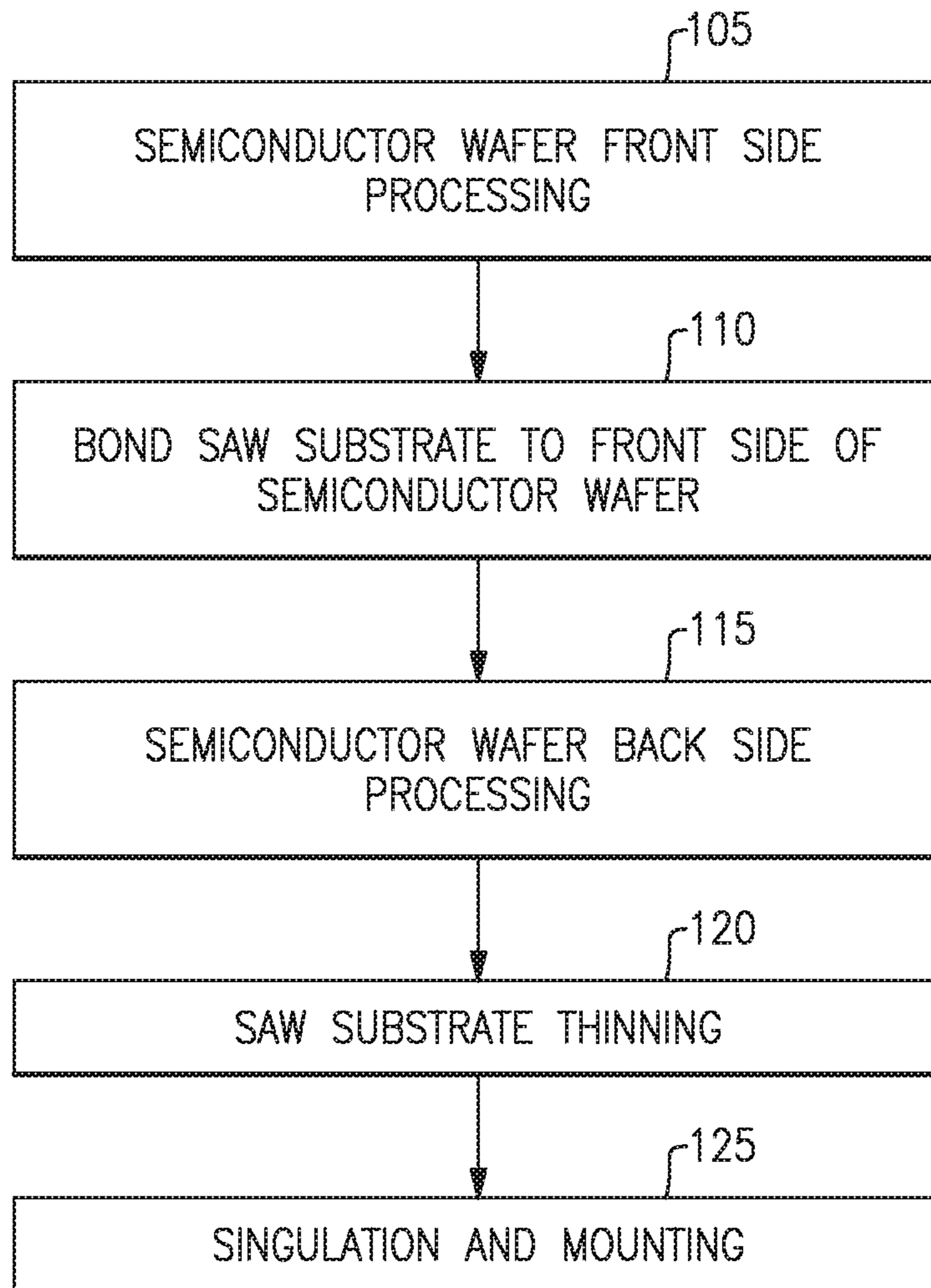

FIG. 1B

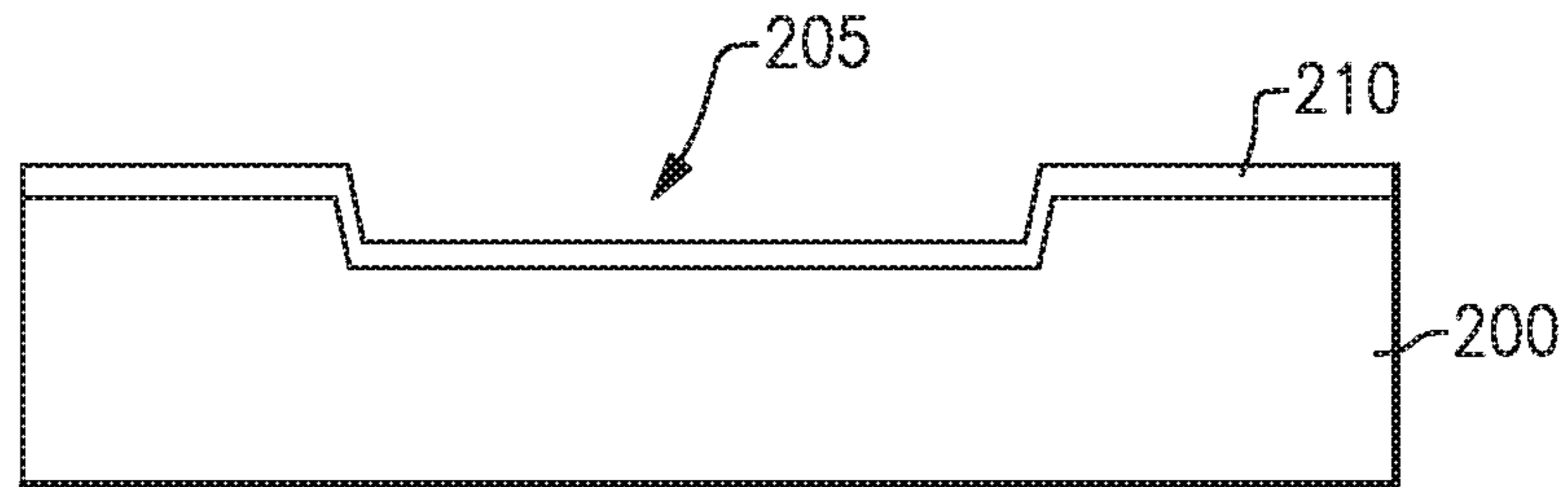

FIG.2A

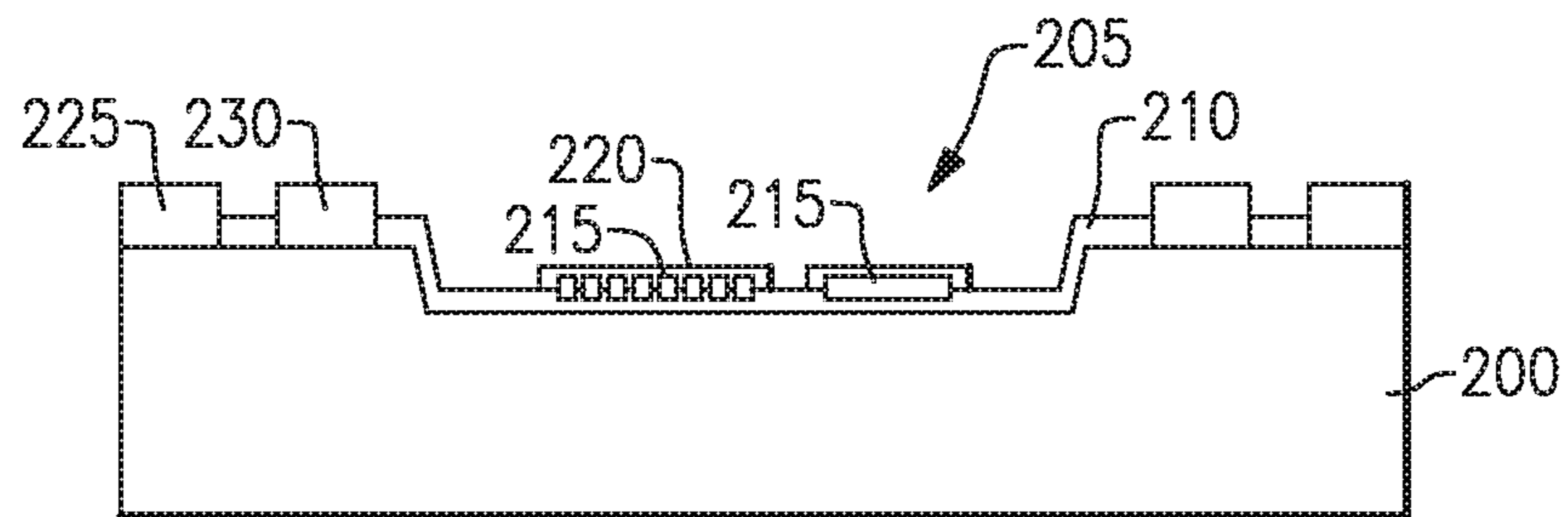

FIG.2B

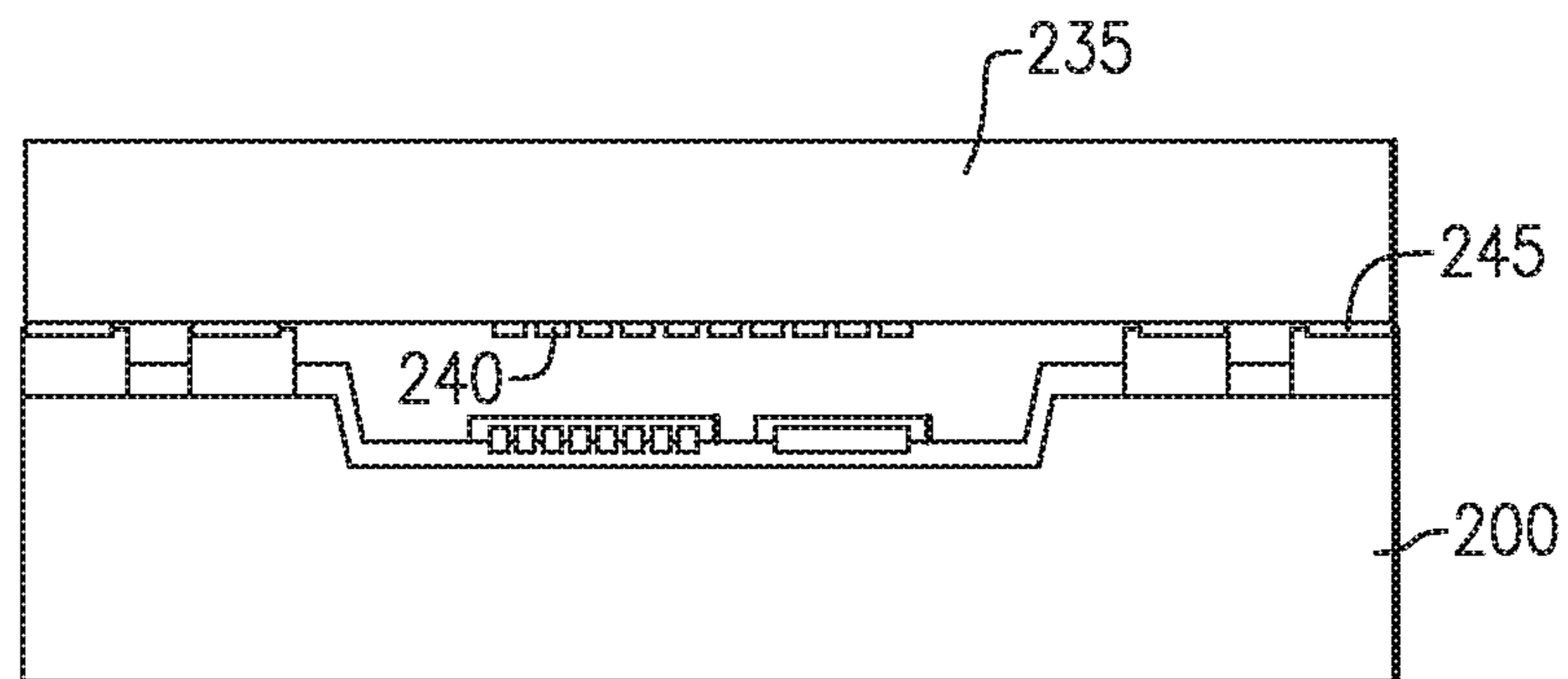

FIG.2C

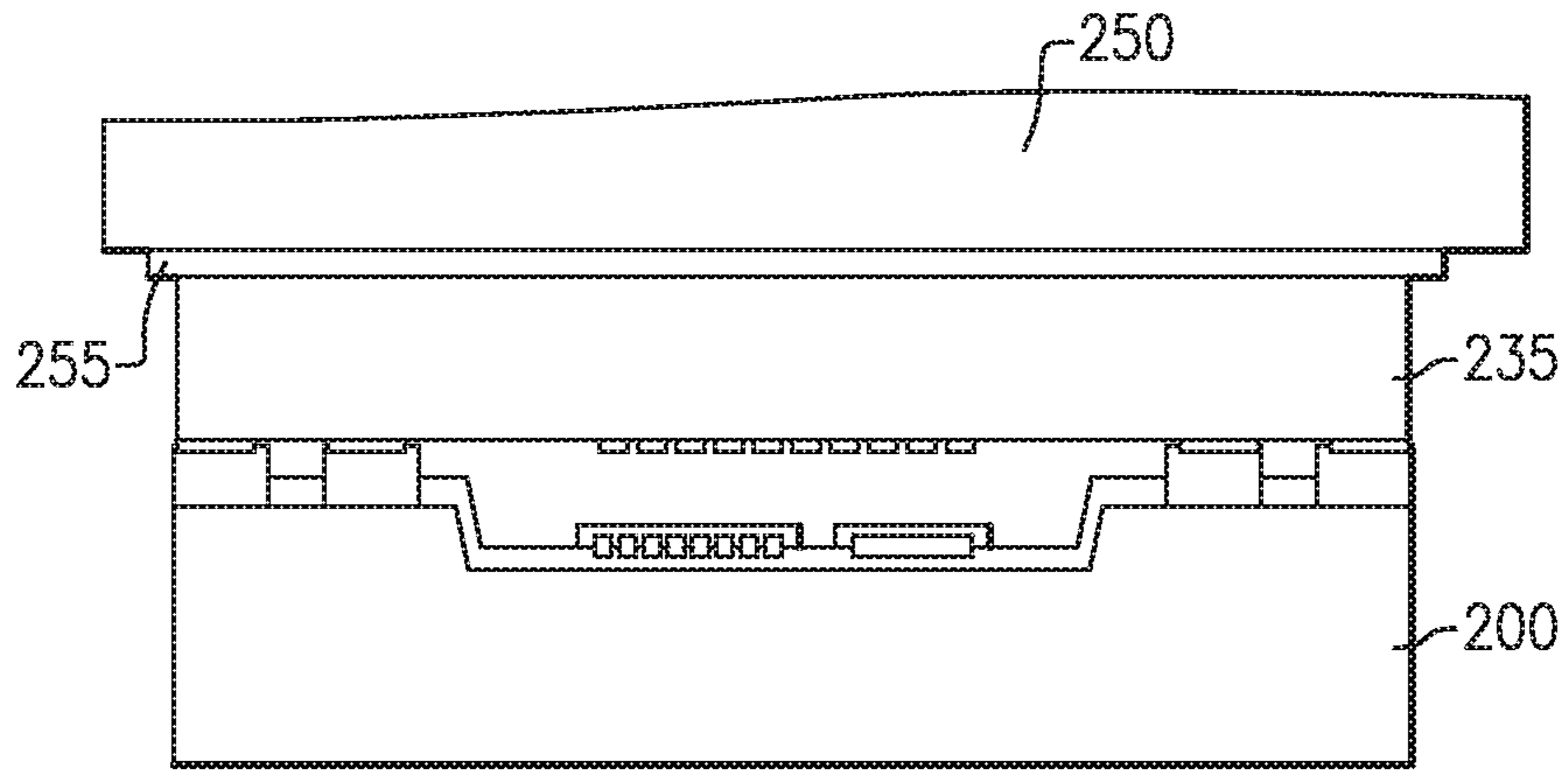

FIG. 2D

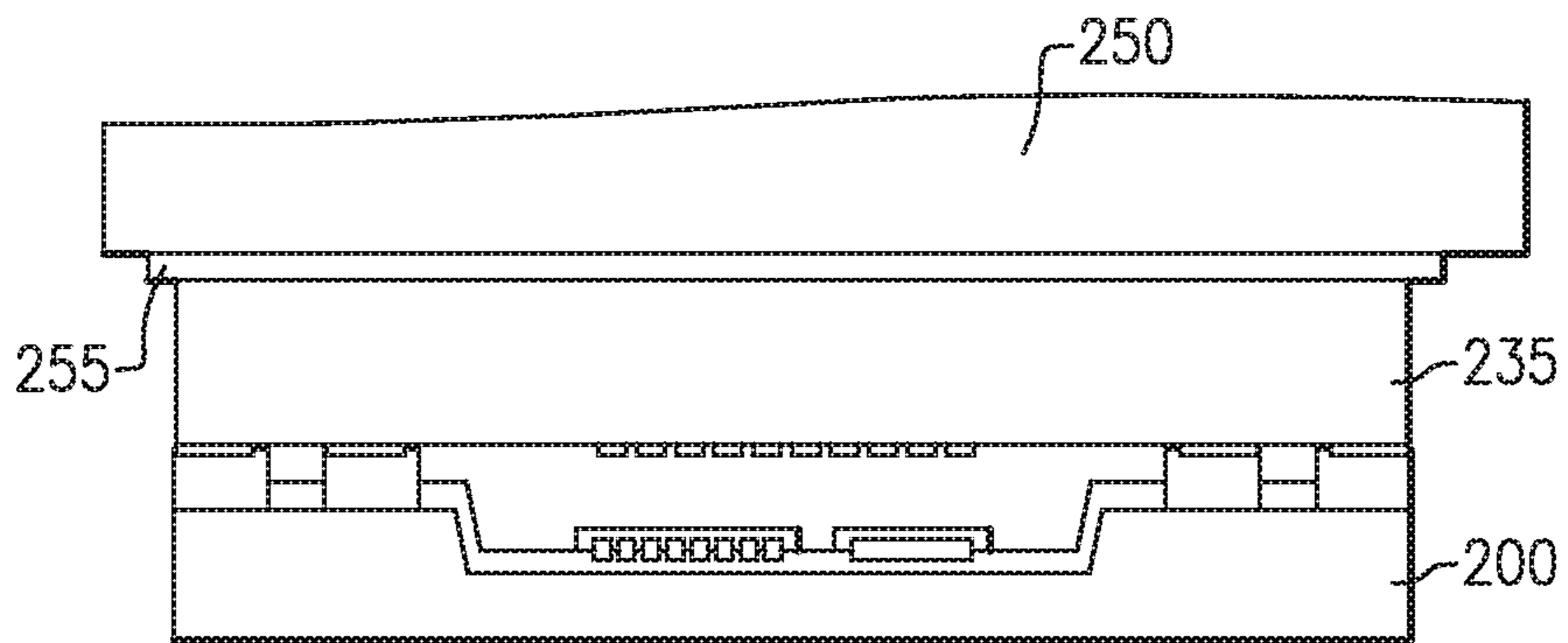

FIG. 2E

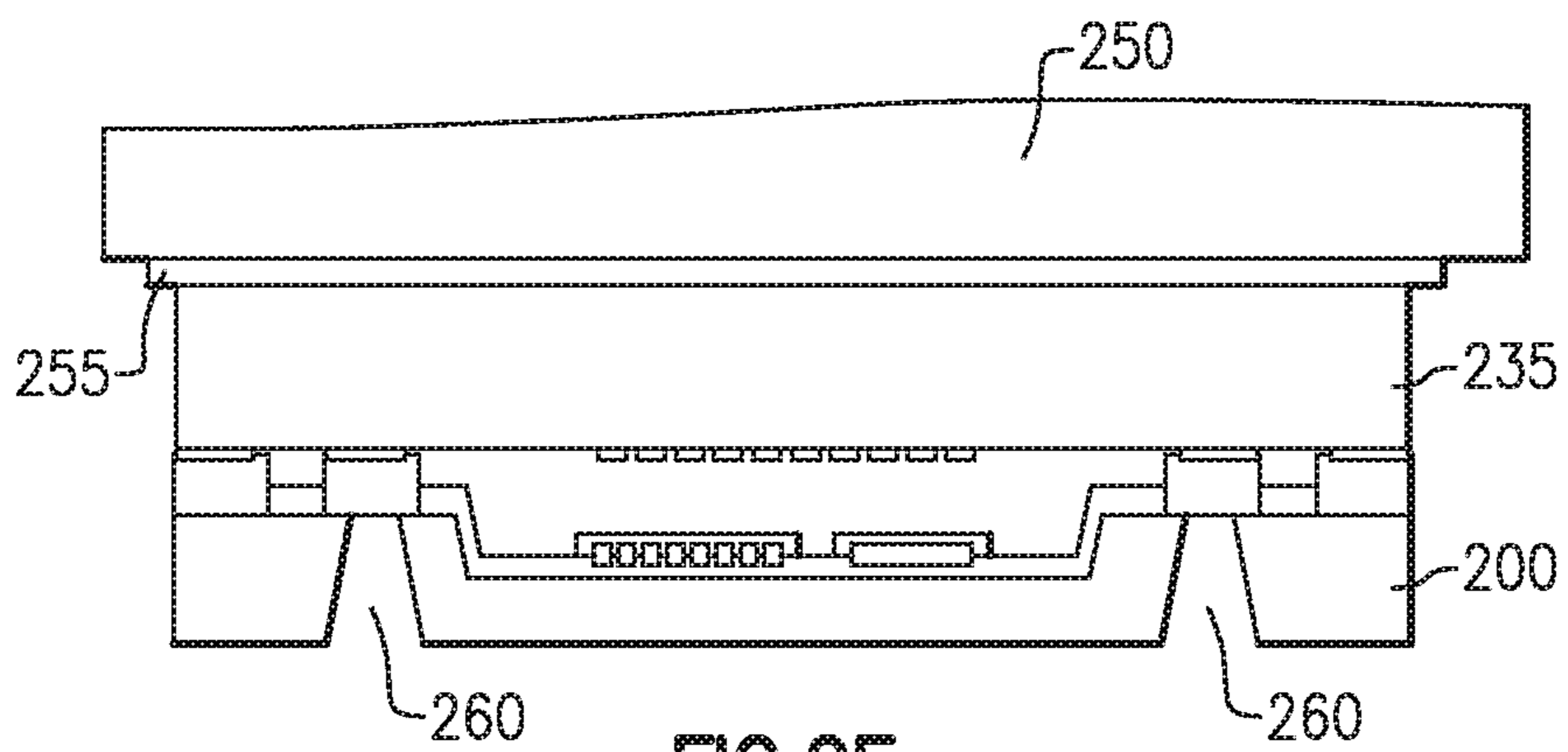

FIG. 2F

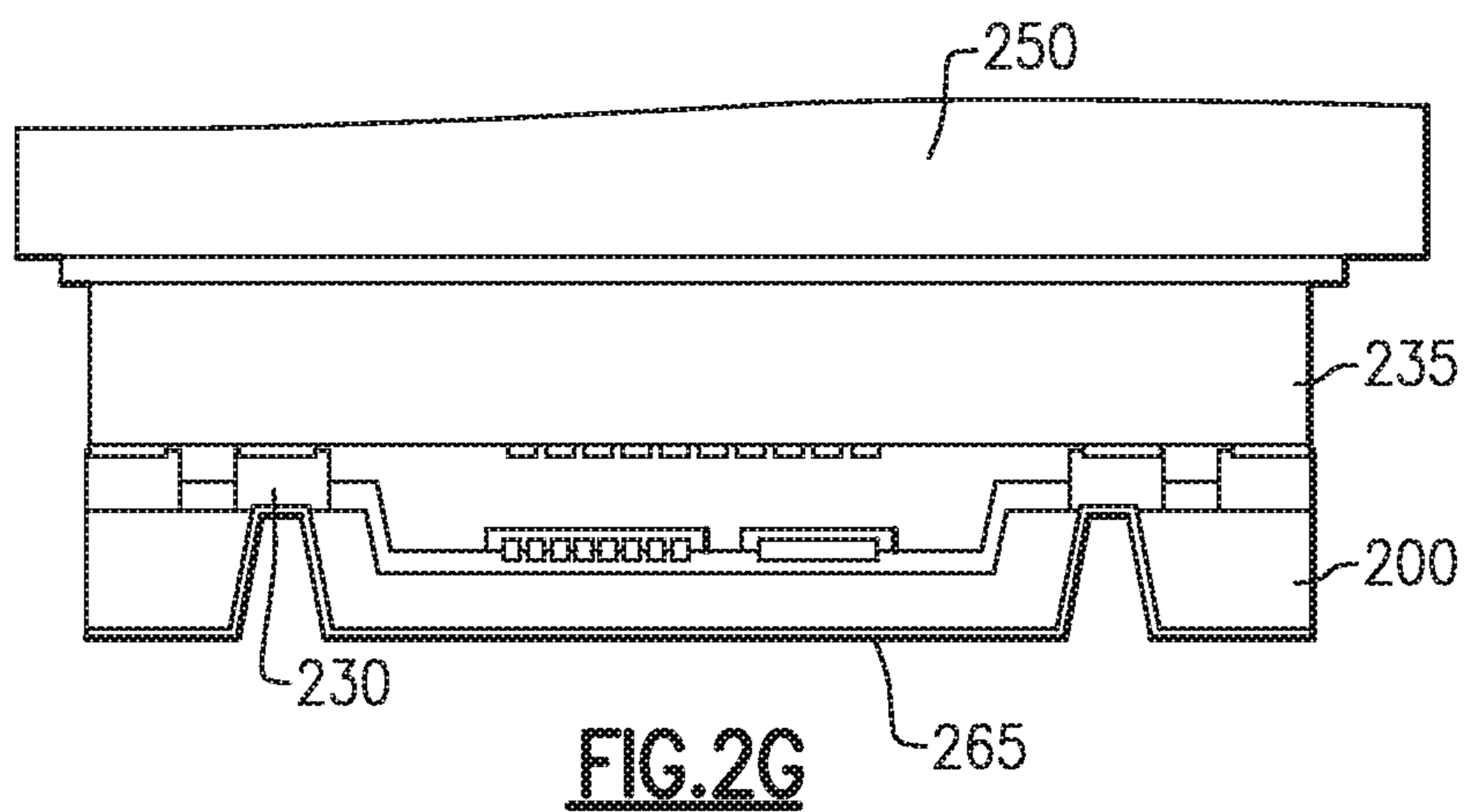

FIG. 2G

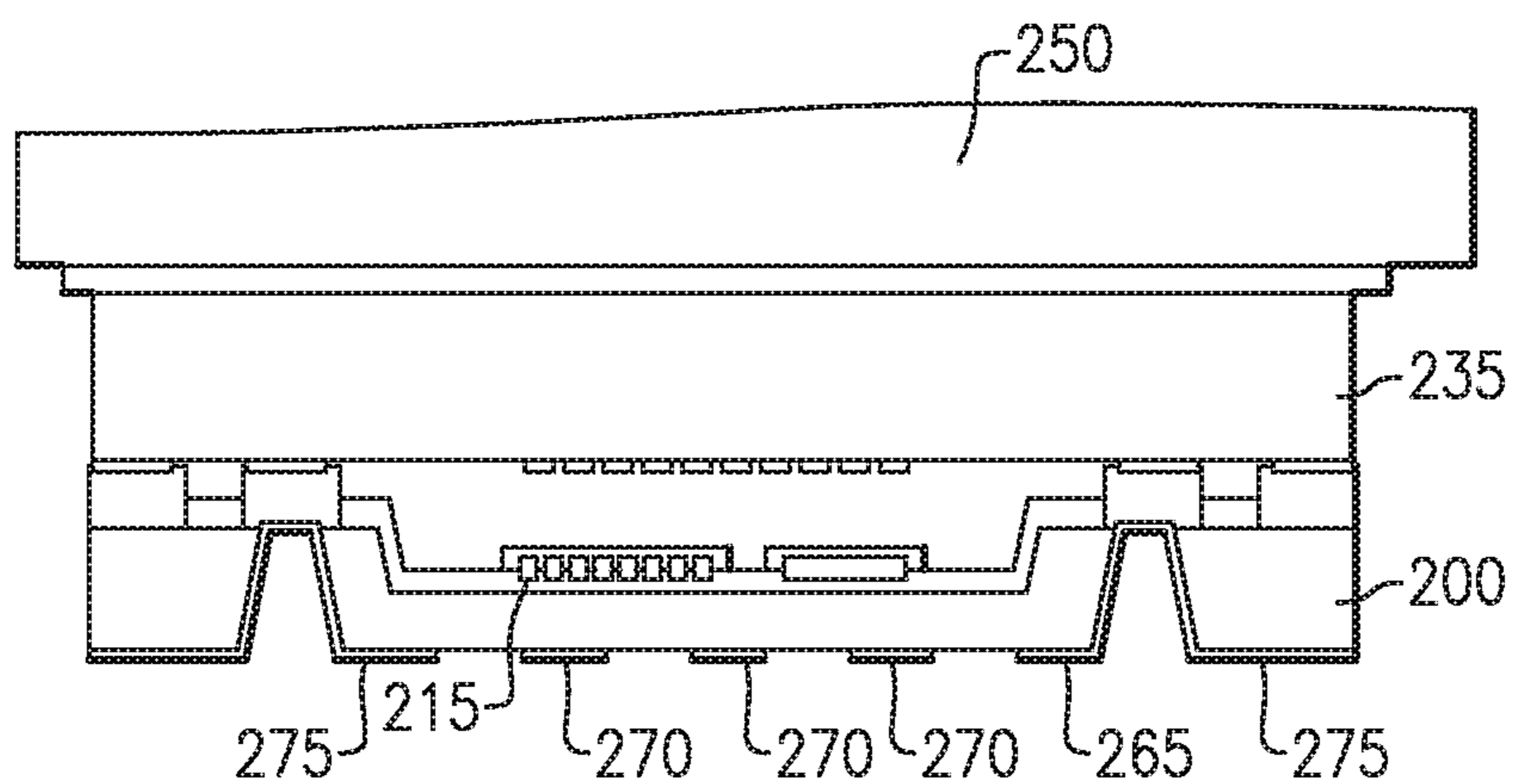

FIG. 2H

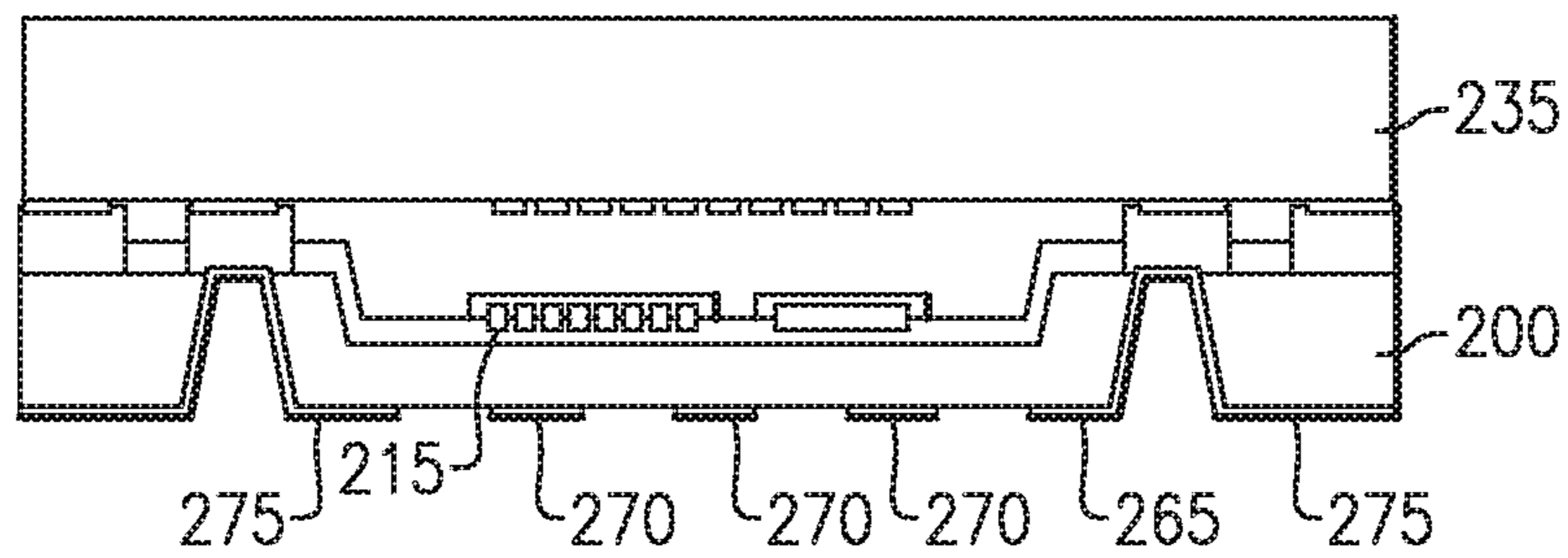

FIG. 2I

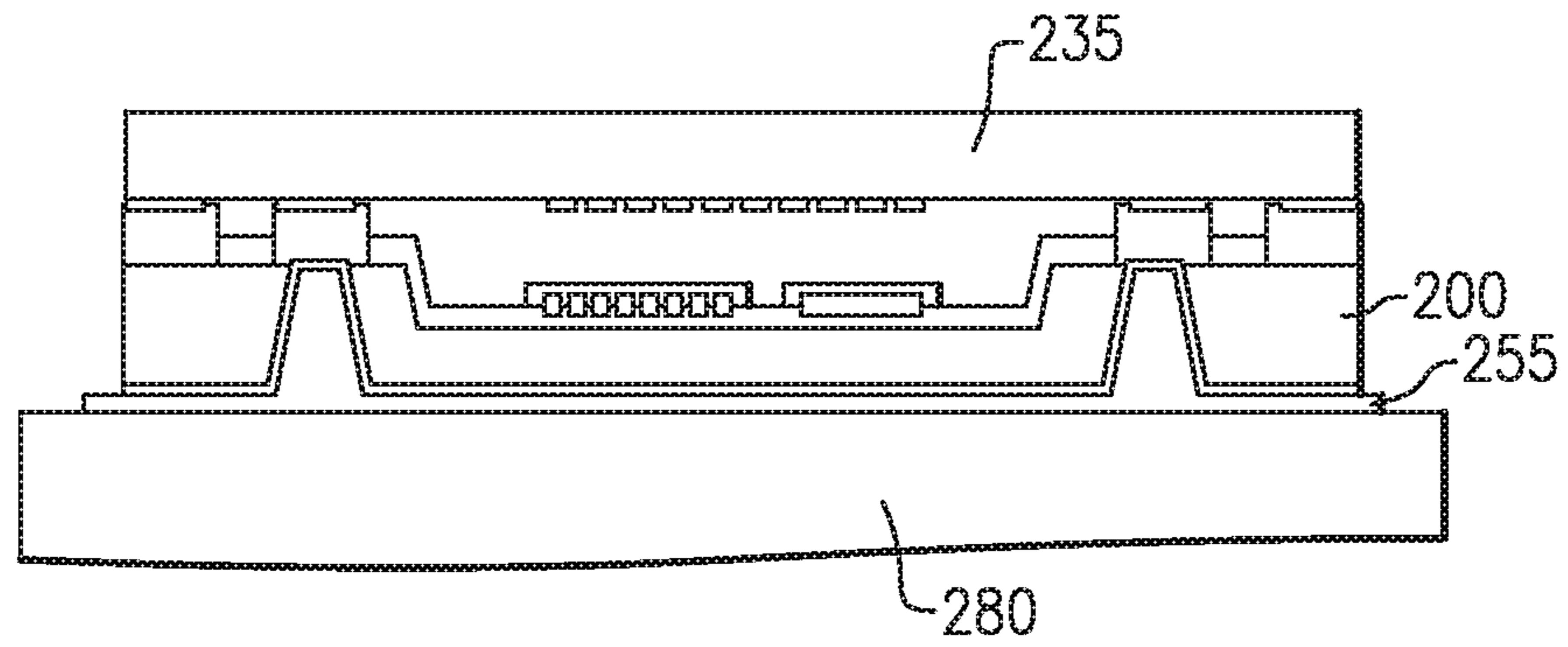

FIG.2J

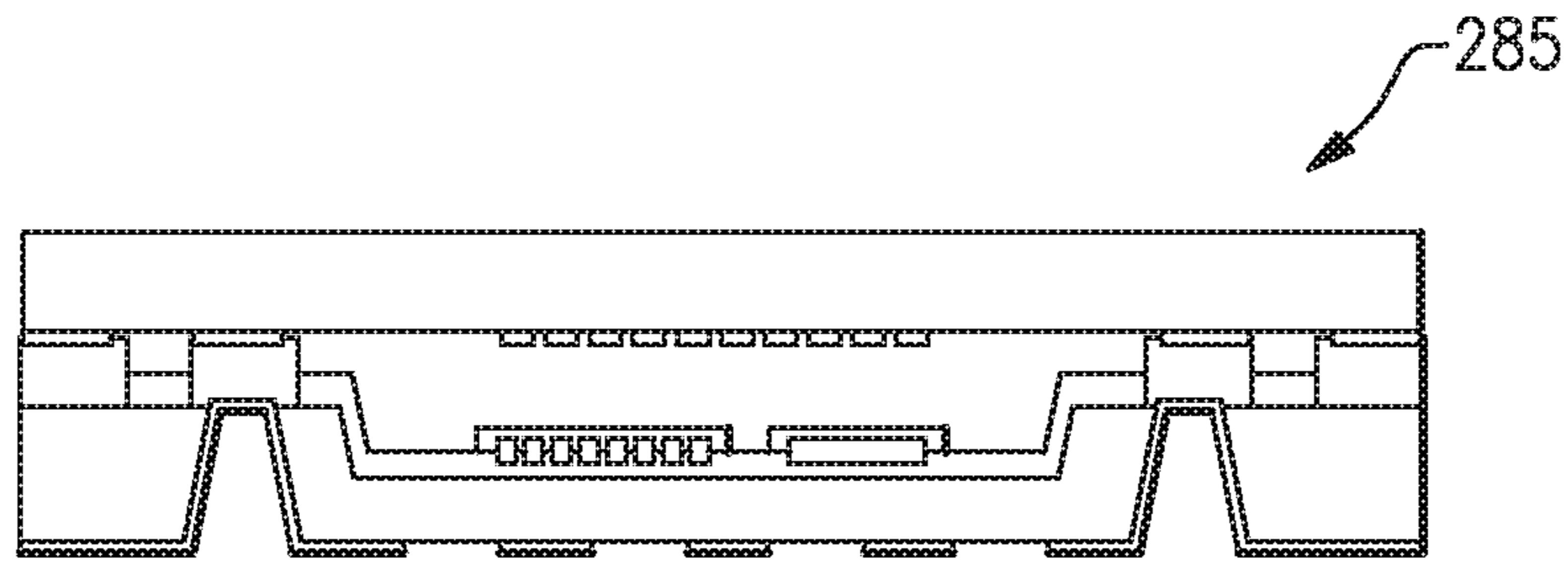

FIG.2K

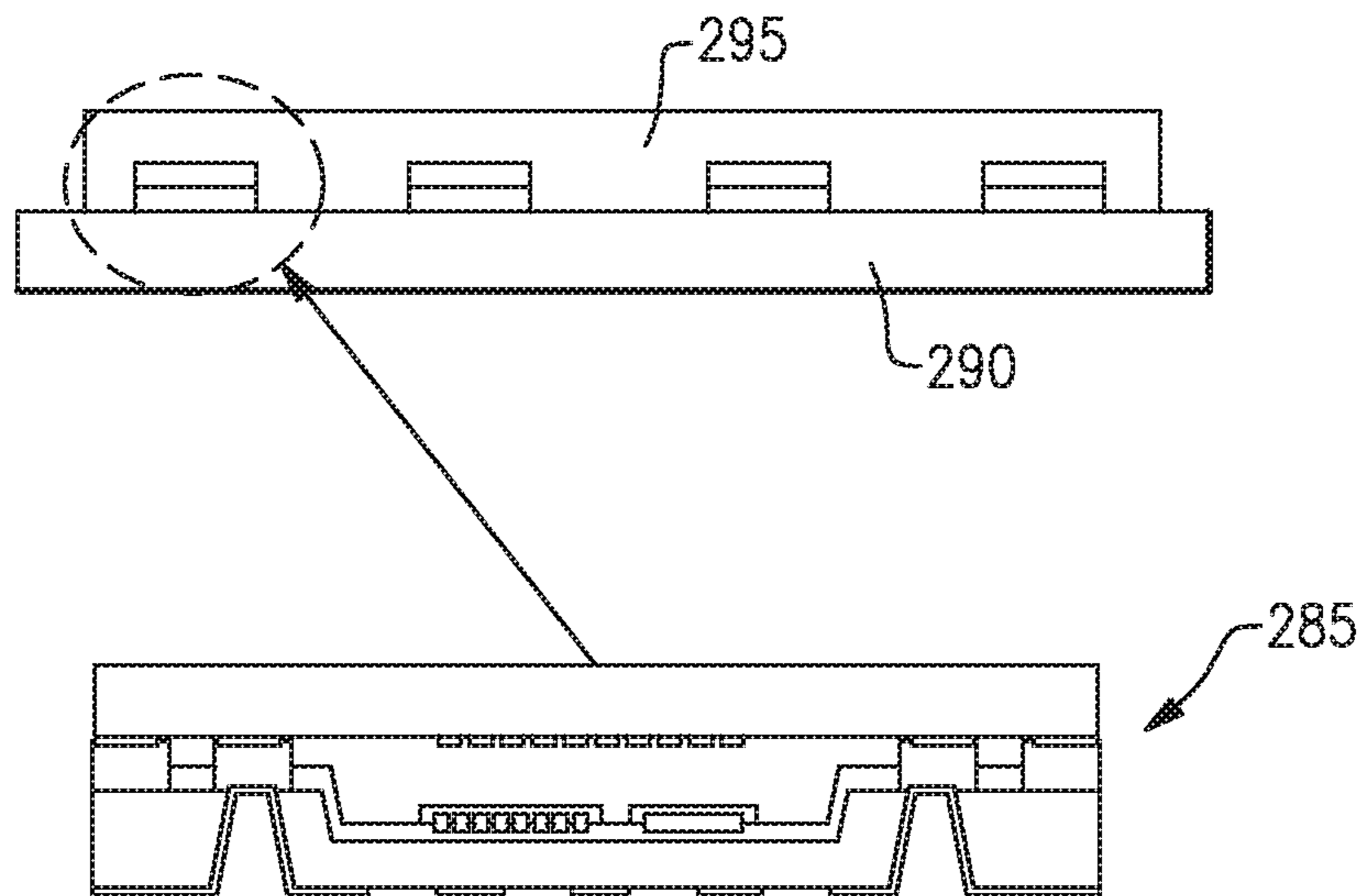

FIG.2L

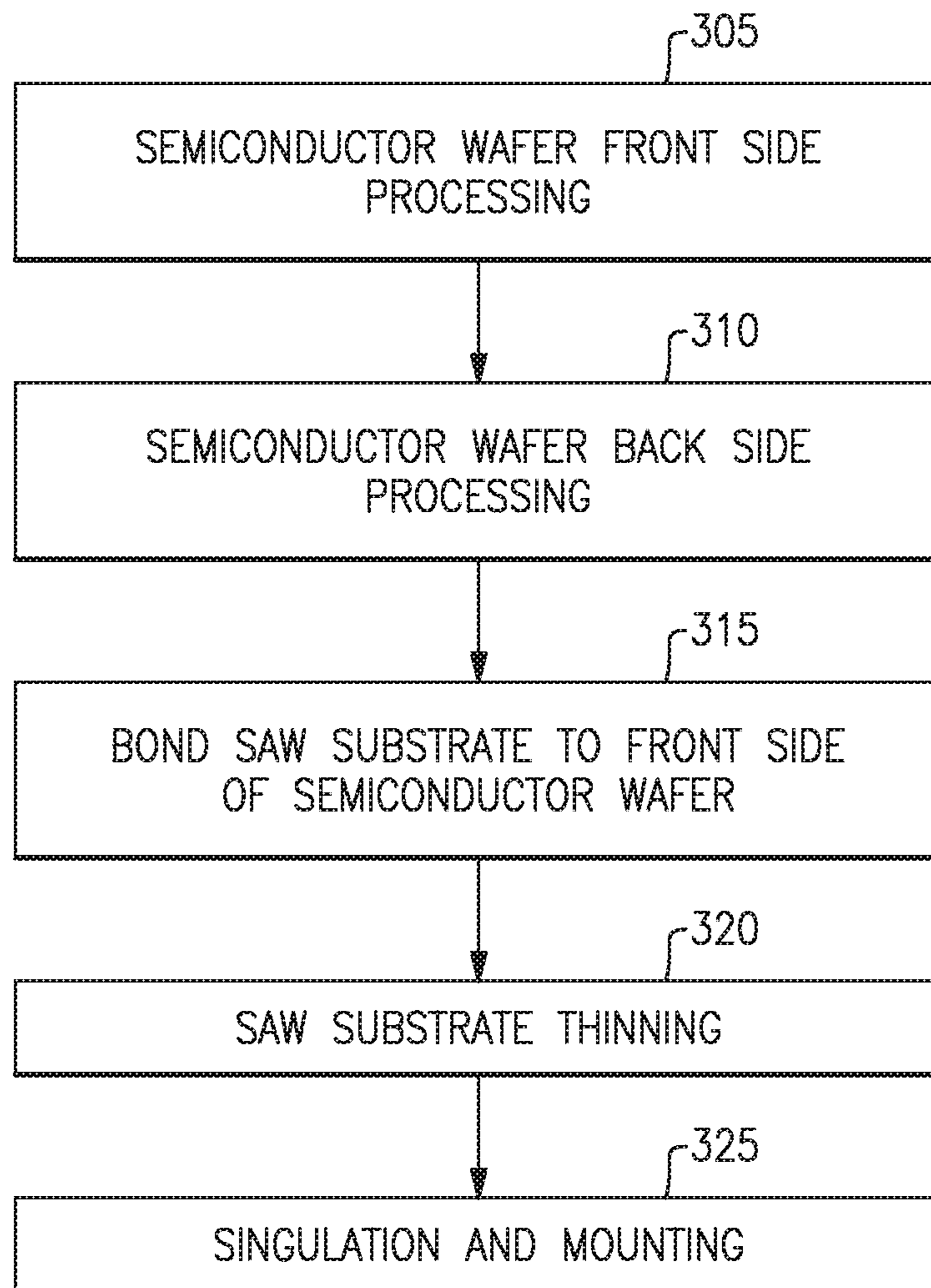

FIG.3

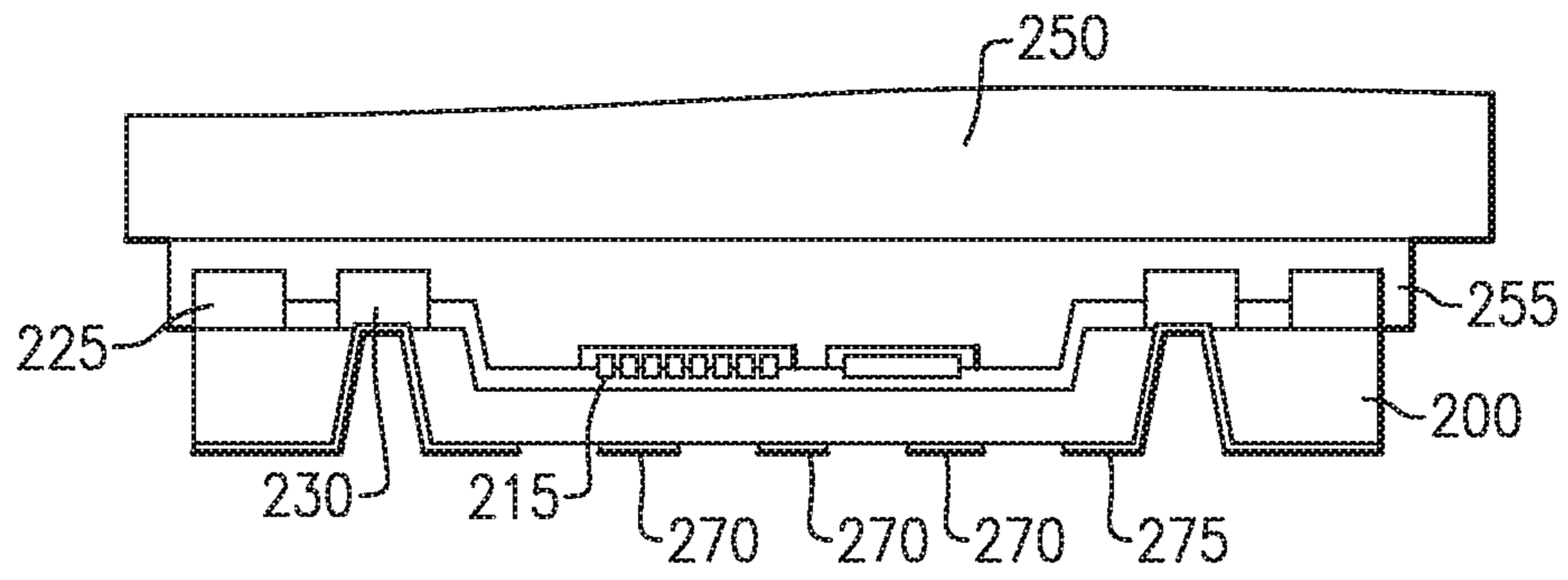

FIG. 4A

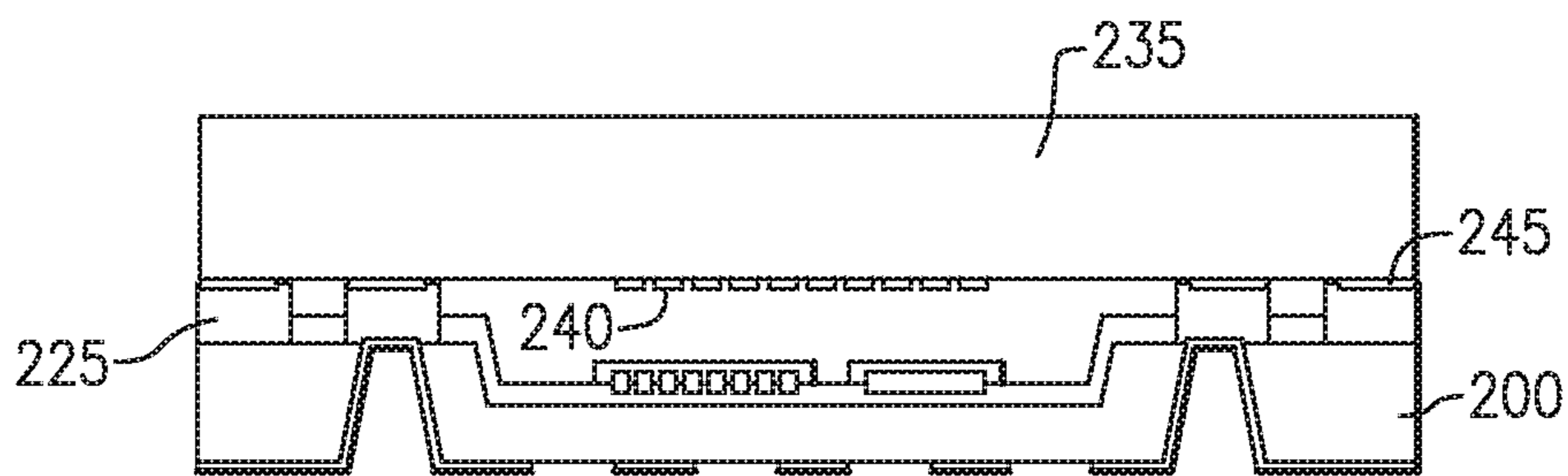

FIG. 4B

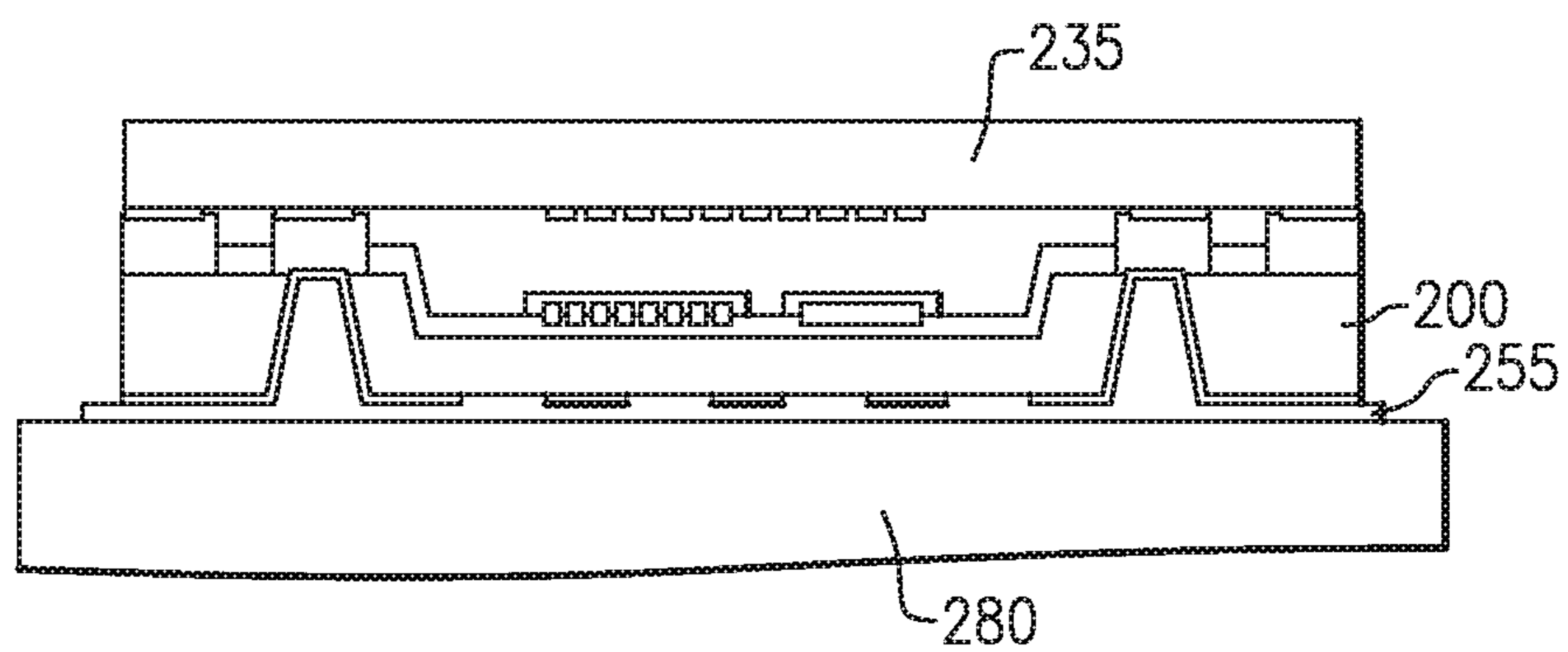

FIG. 4C

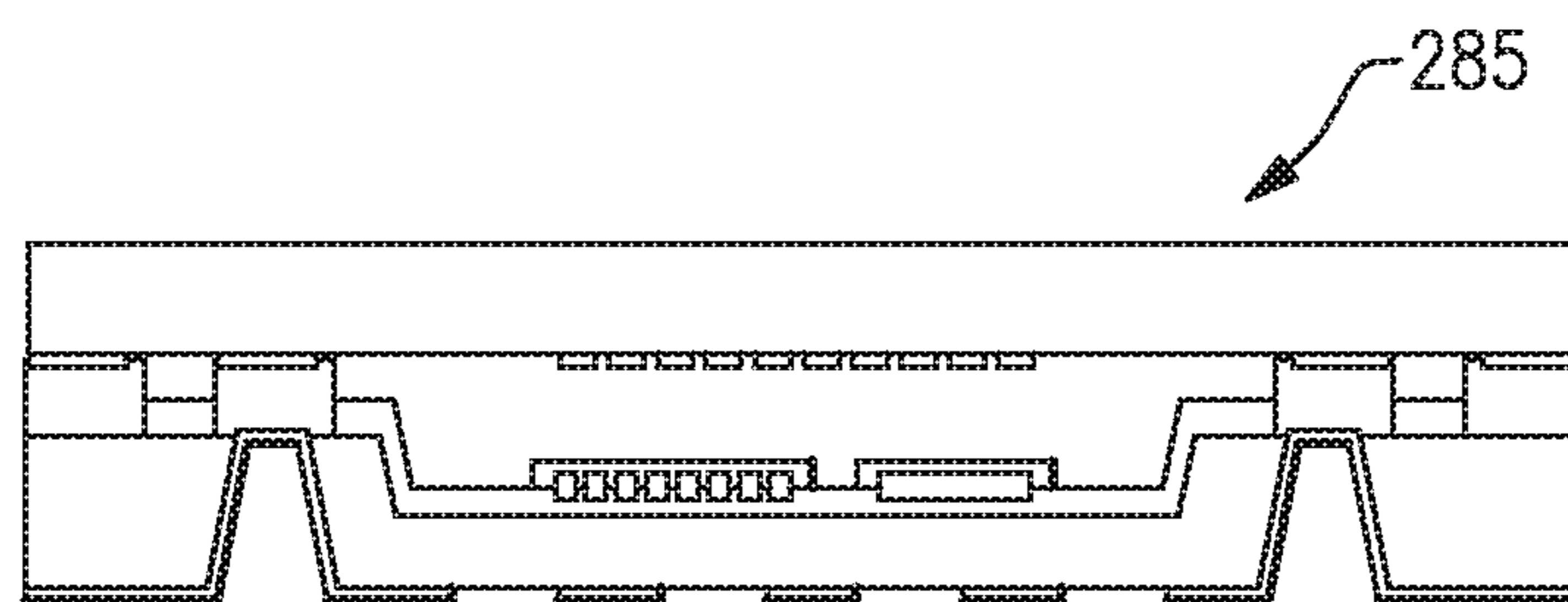

FIG.4D

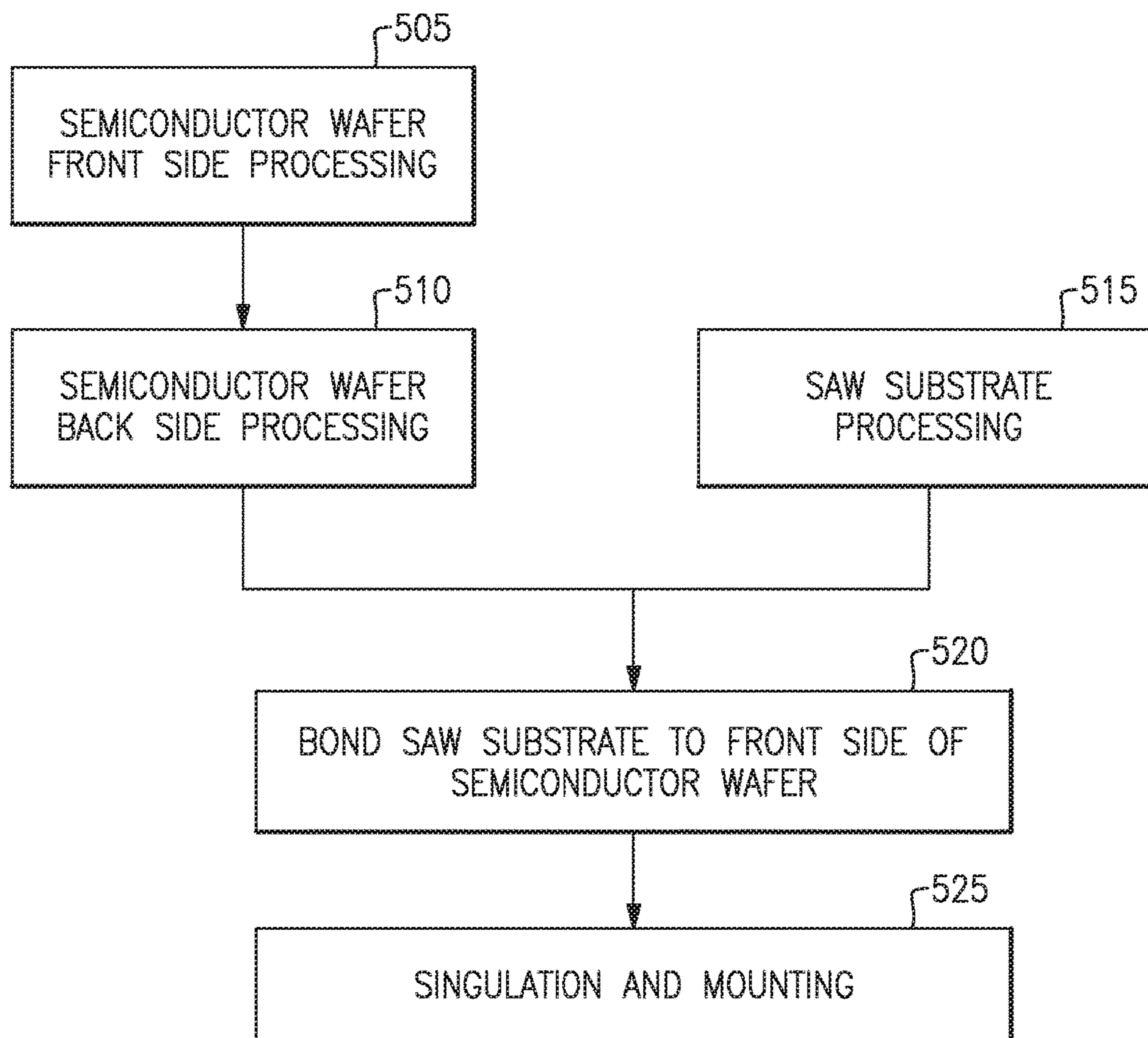

FIG.5

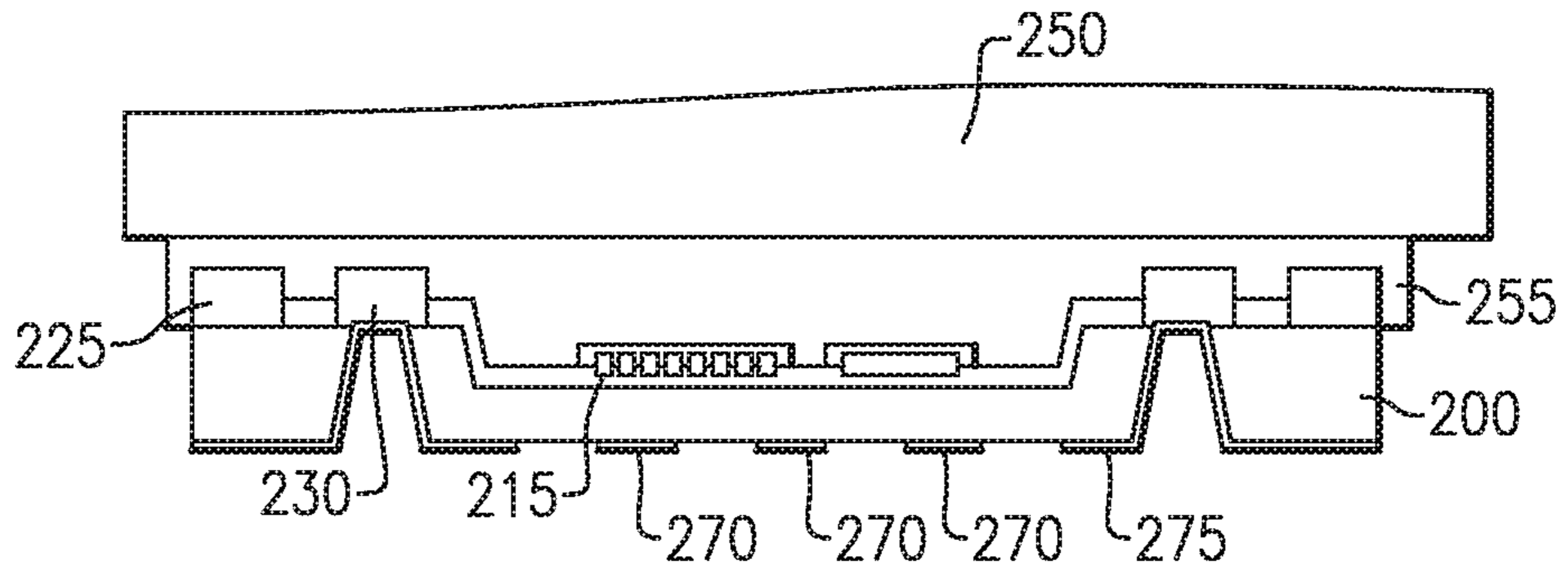

FIG. 6A

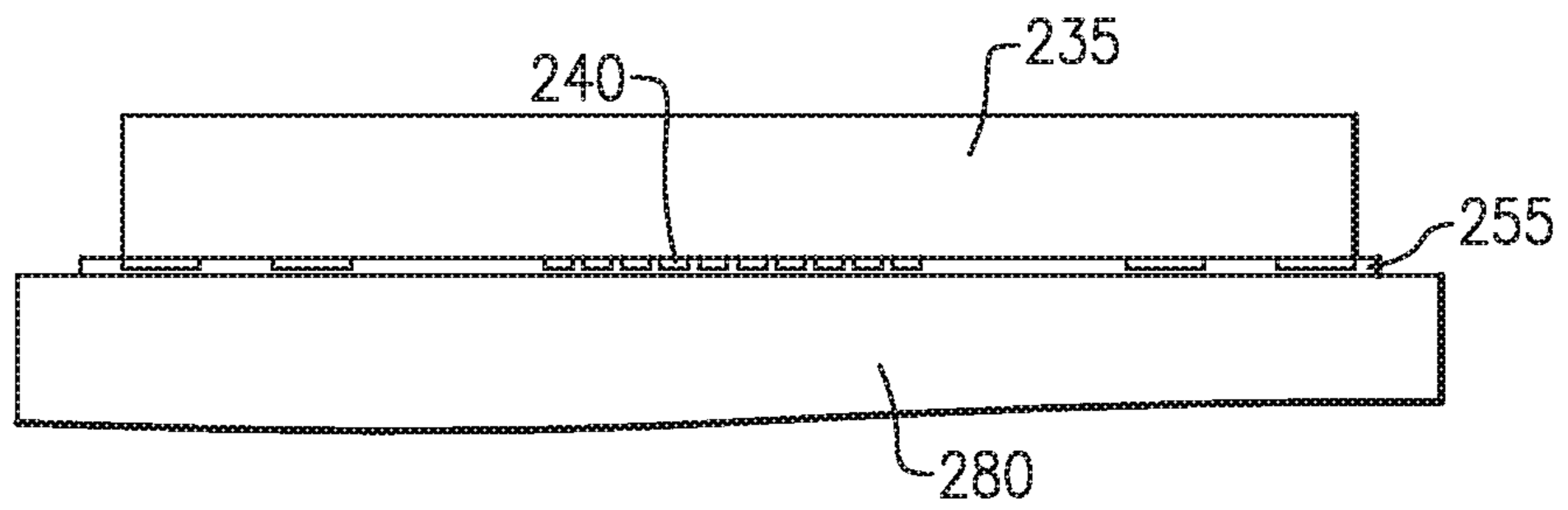

FIG. 6B

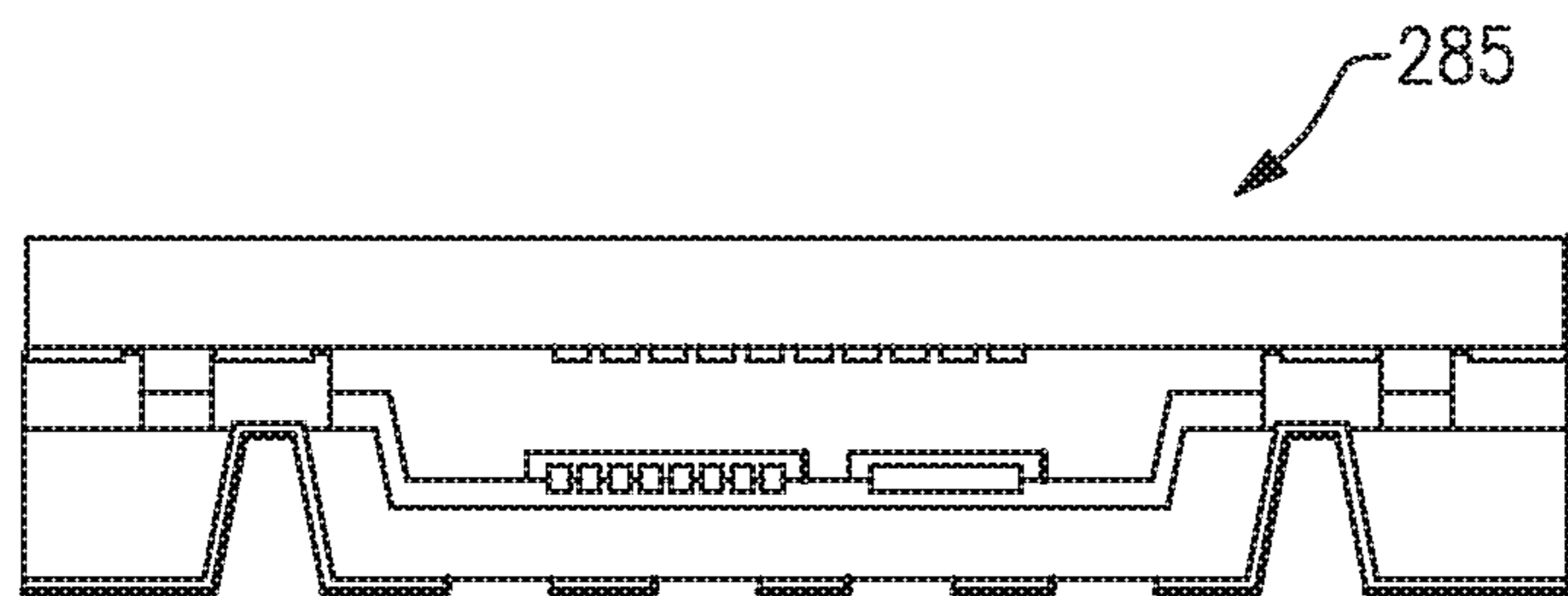

FIG. 6C

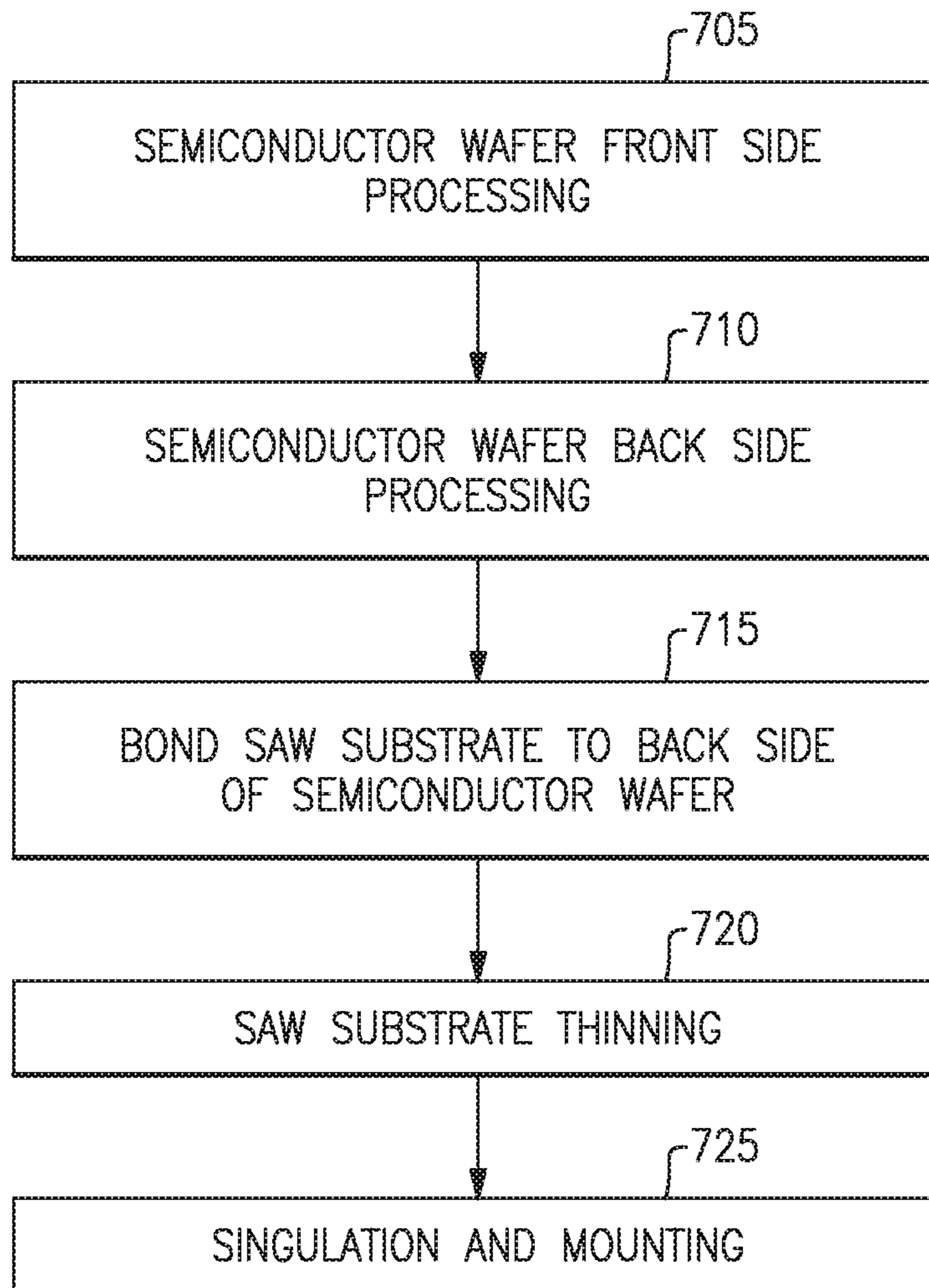

FIG.7

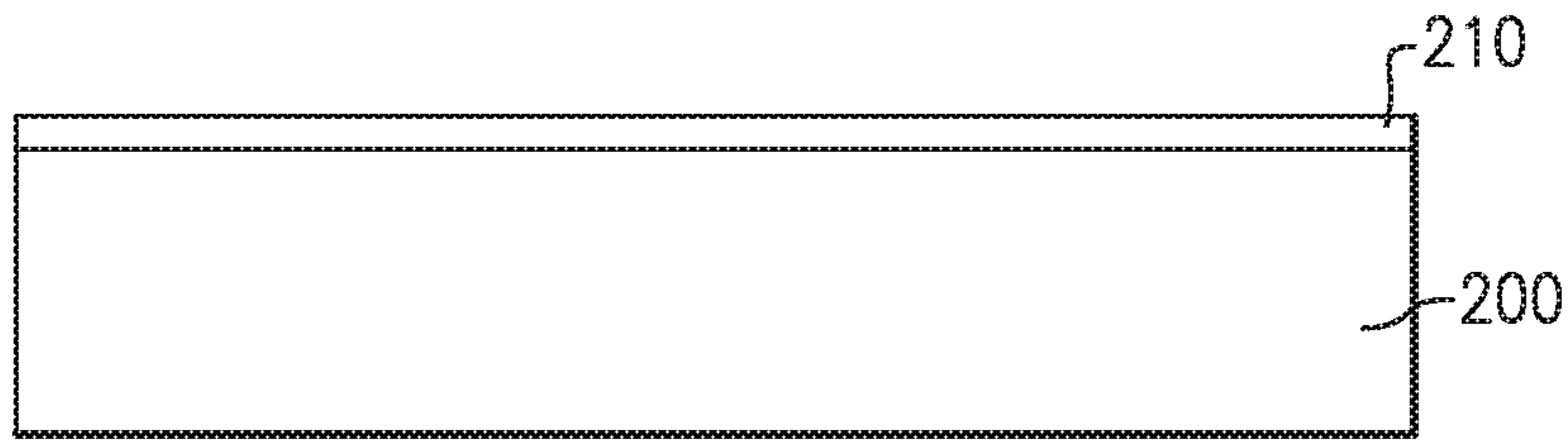

FIG. 8A

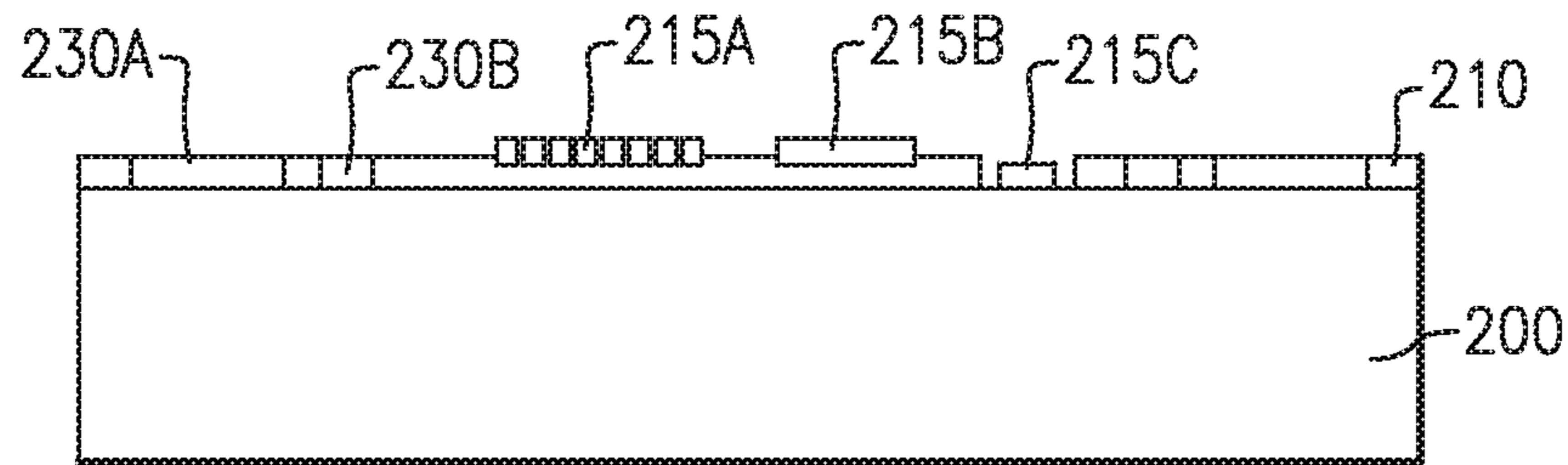

FIG. 8B

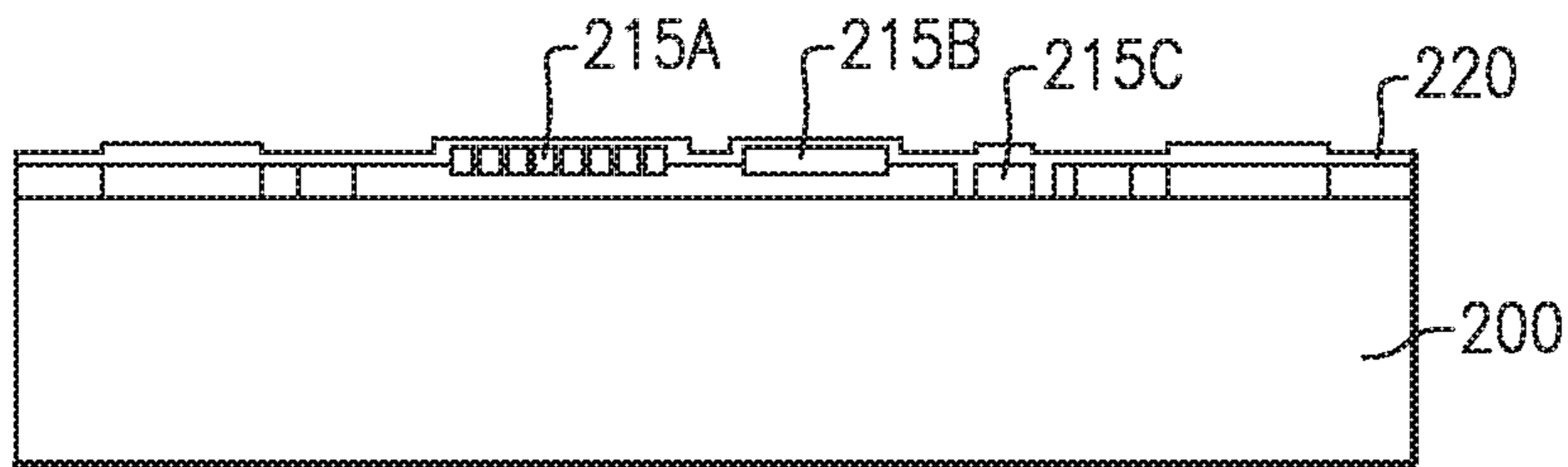

FIG. 8C

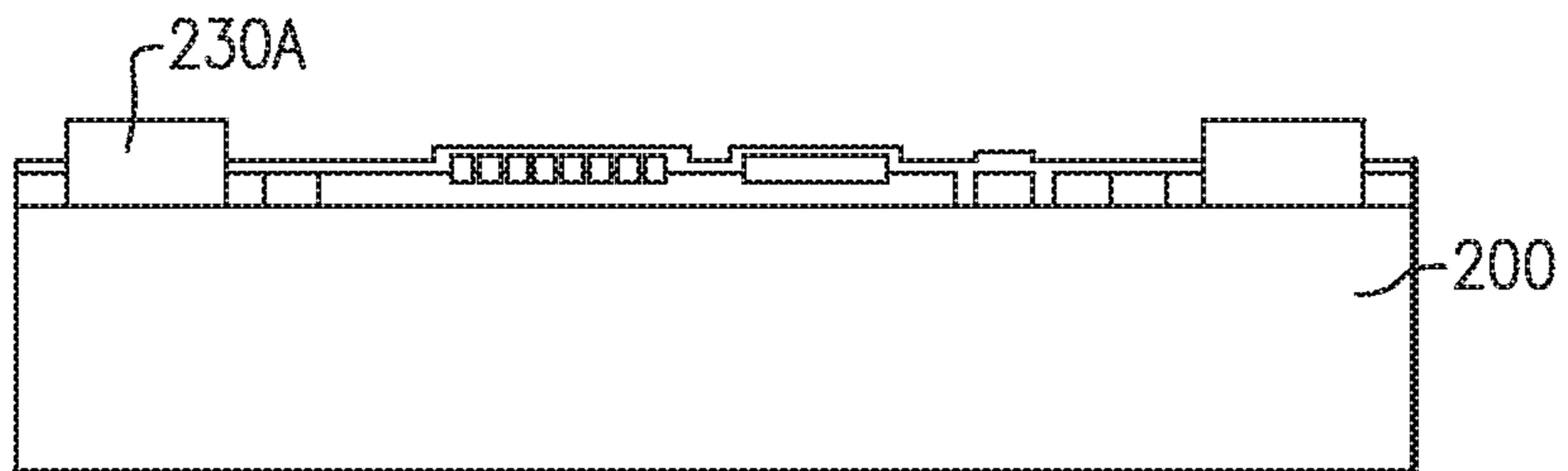

FIG. 8D

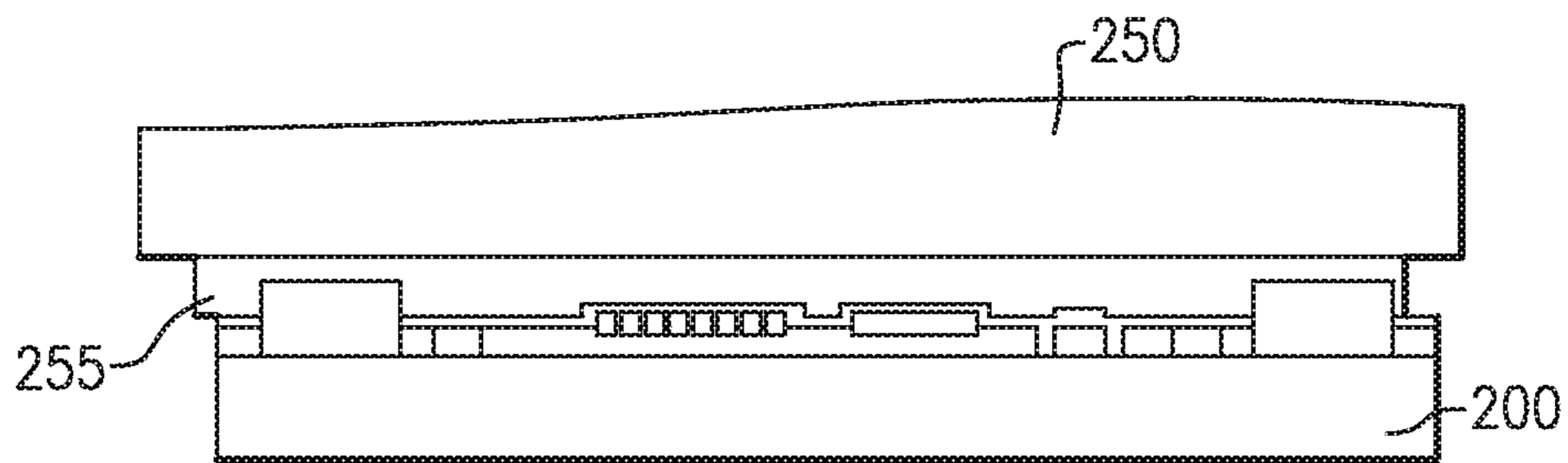

FIG. 8E

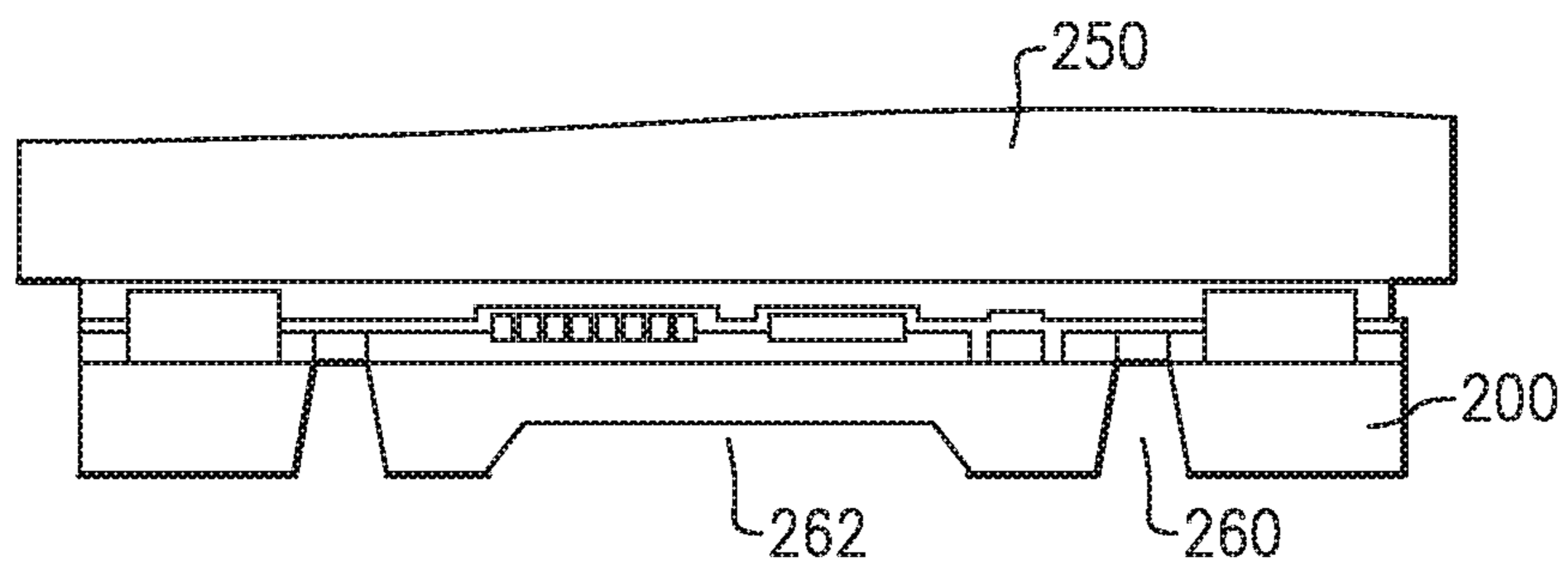

FIG. 8F

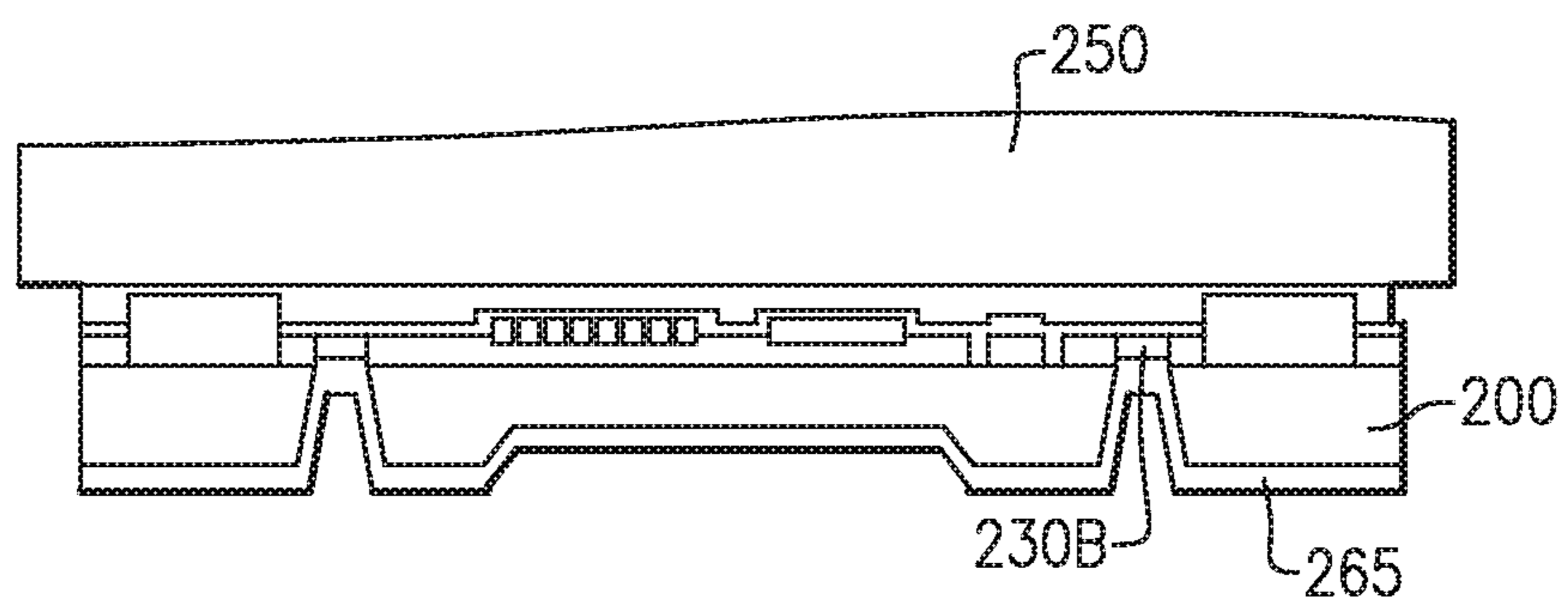

FIG. 8G

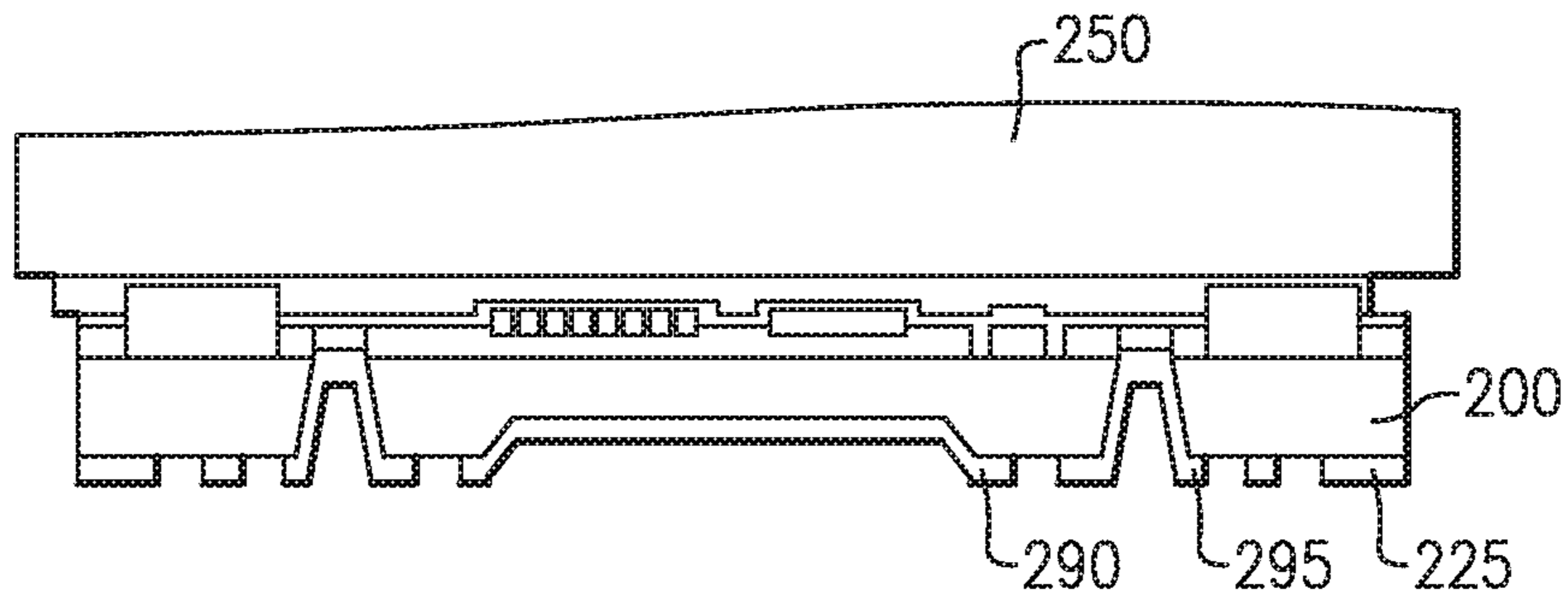

FIG.8H

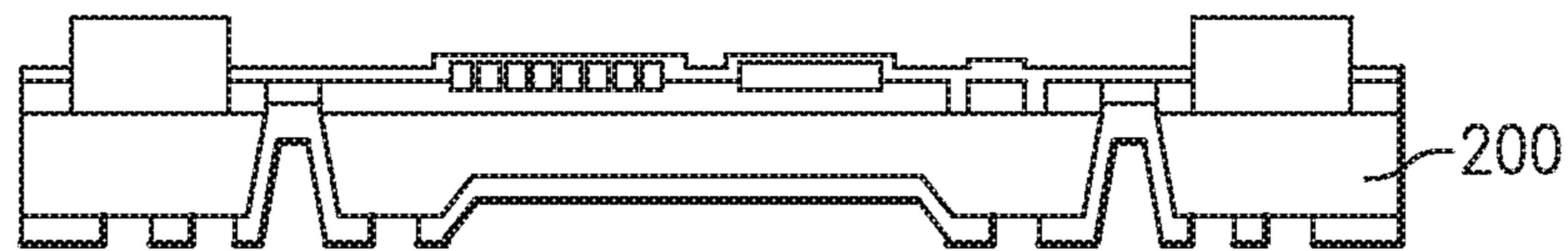

FIG.8I

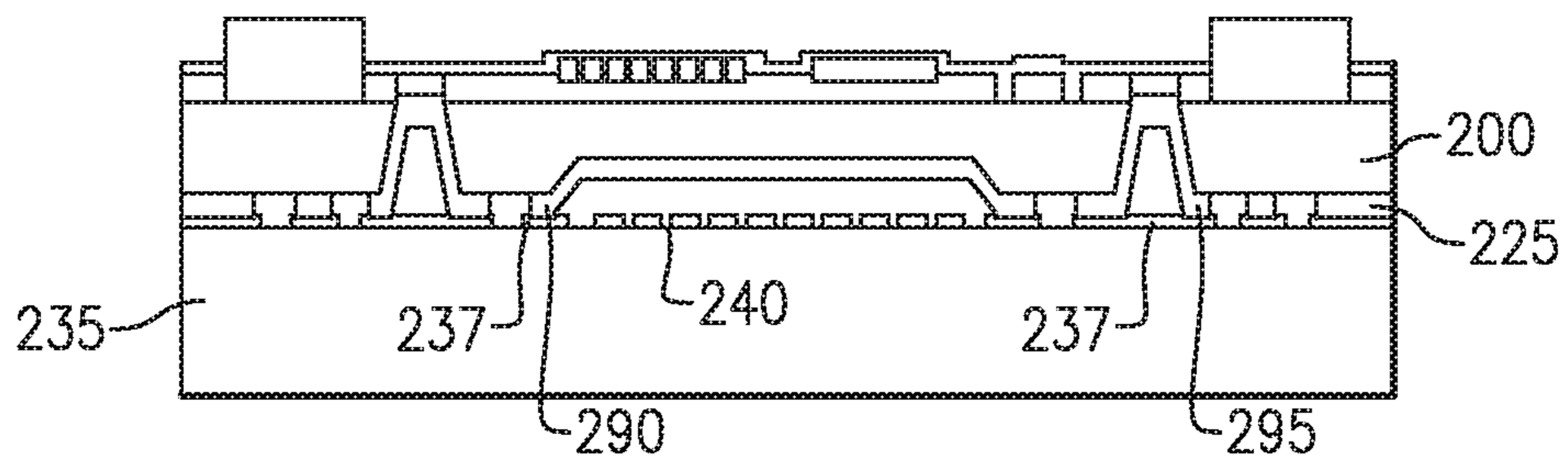

FIG.8J

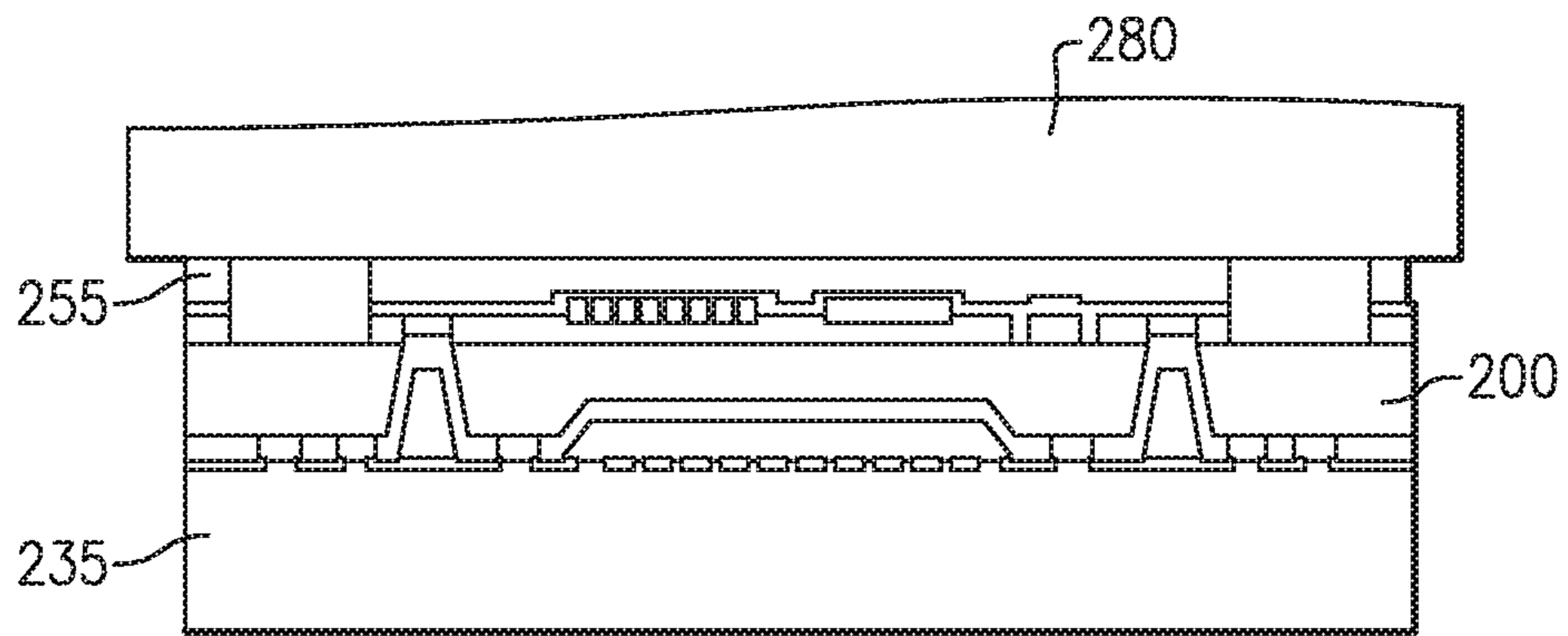

FIG. 8K

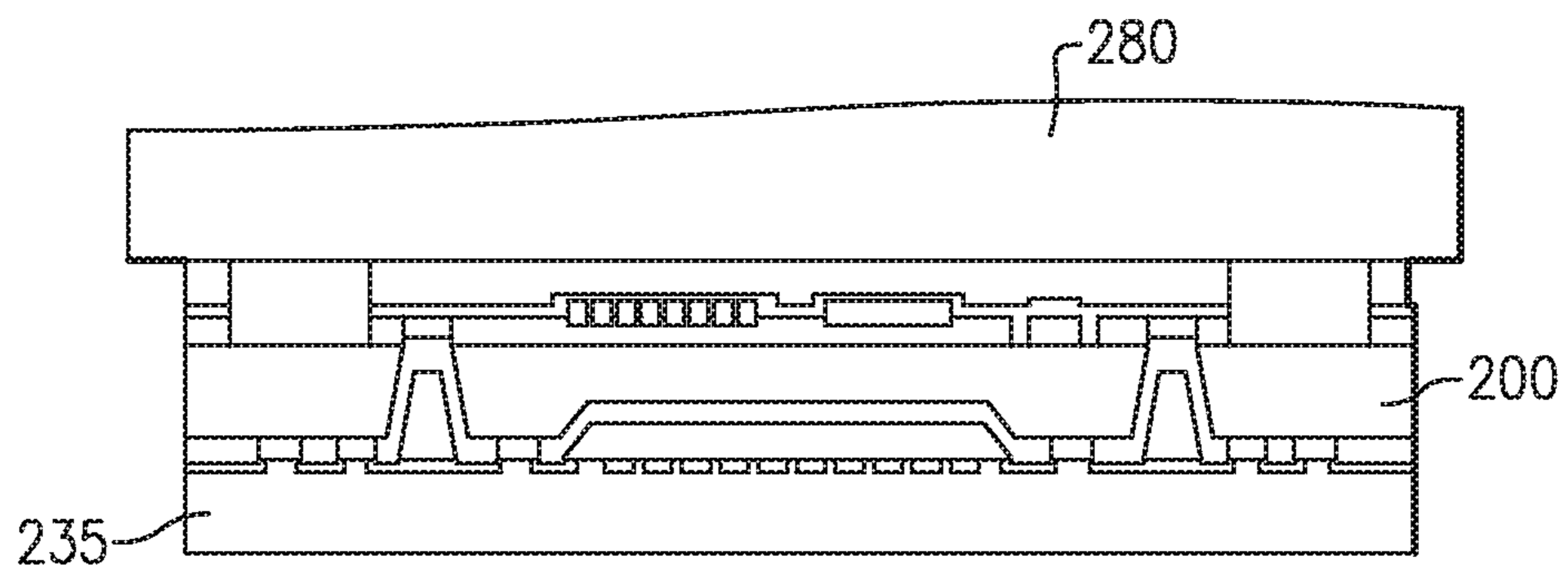

FIG. 8L

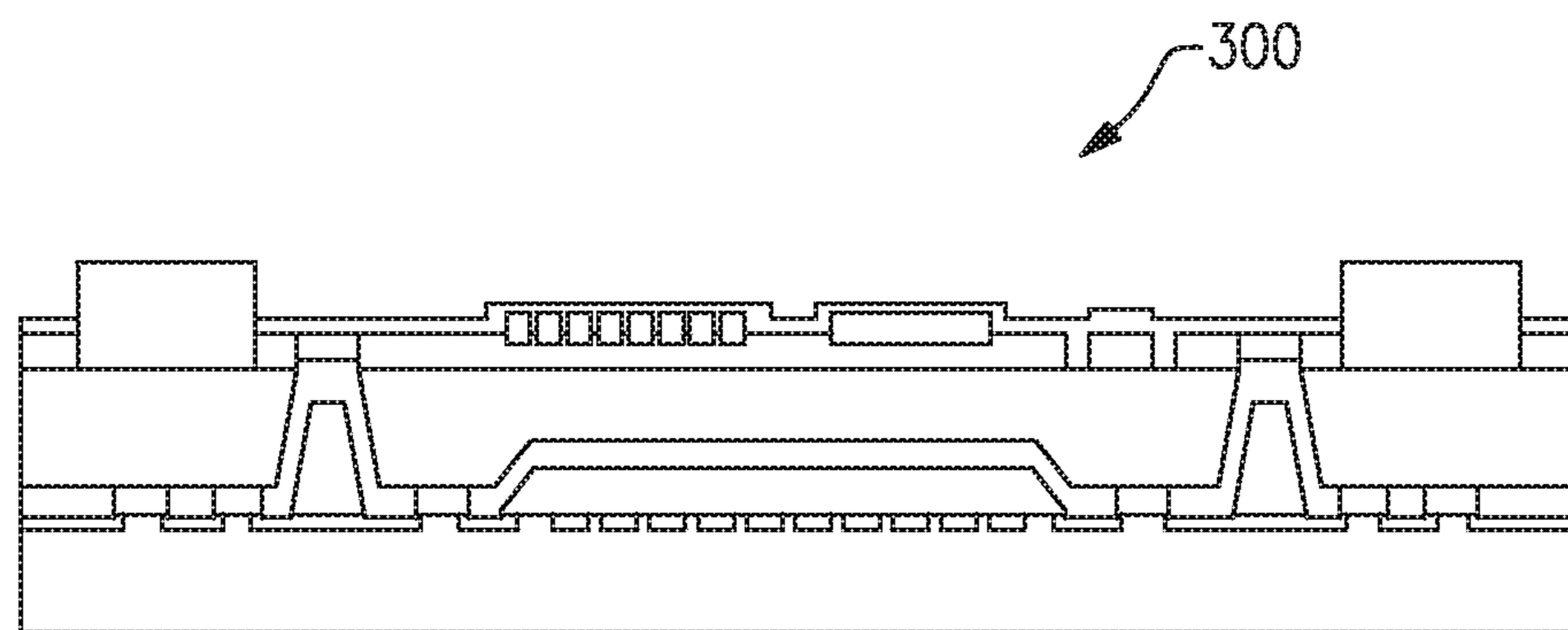

FIG. 8M

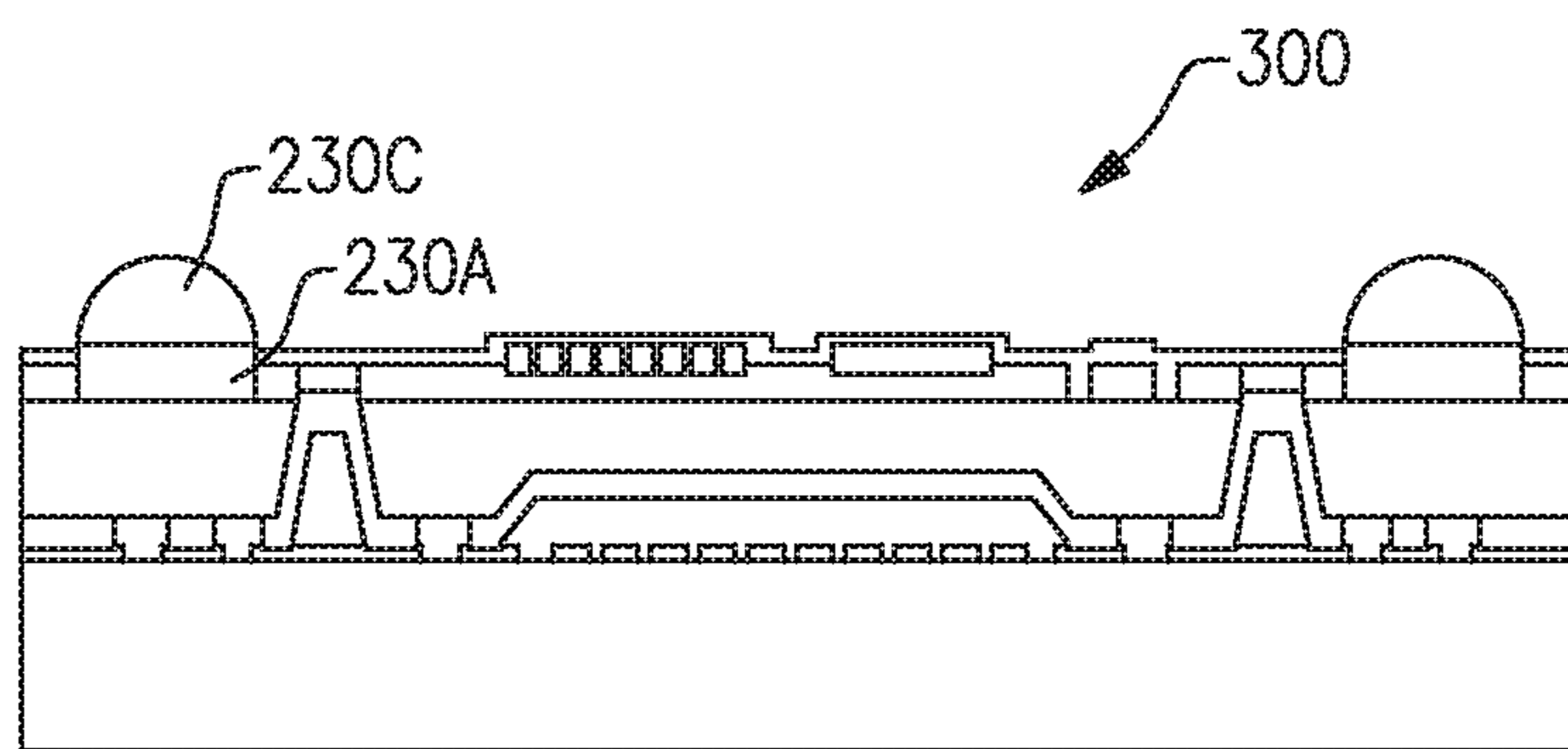

FIG. 8N

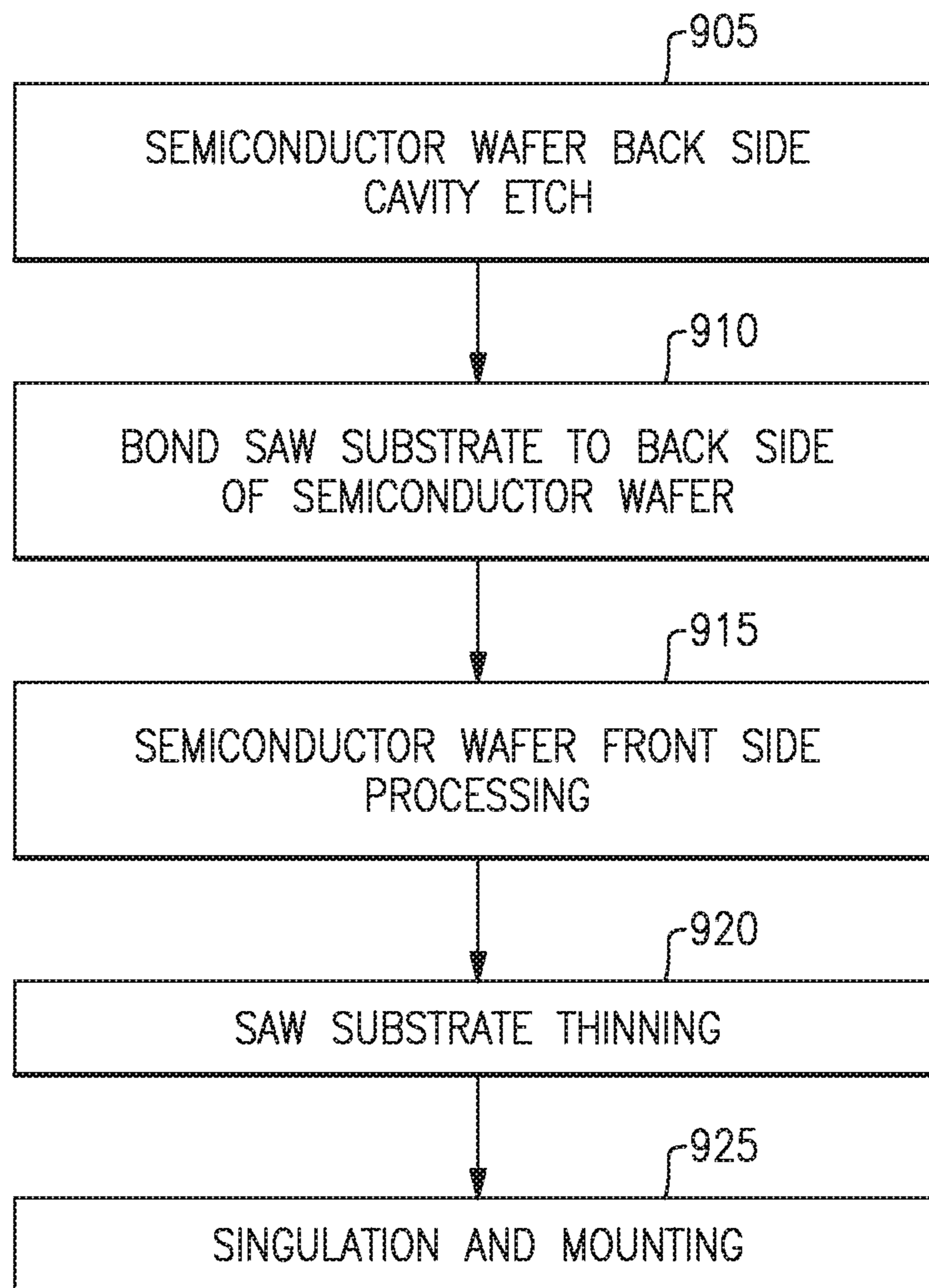

FIG.9

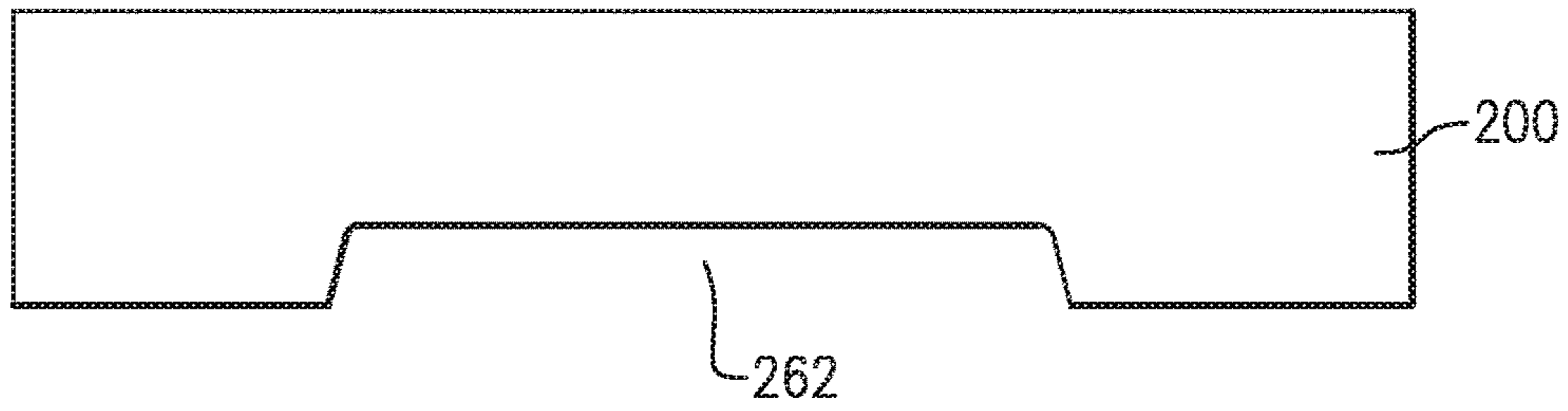

FIG.10A

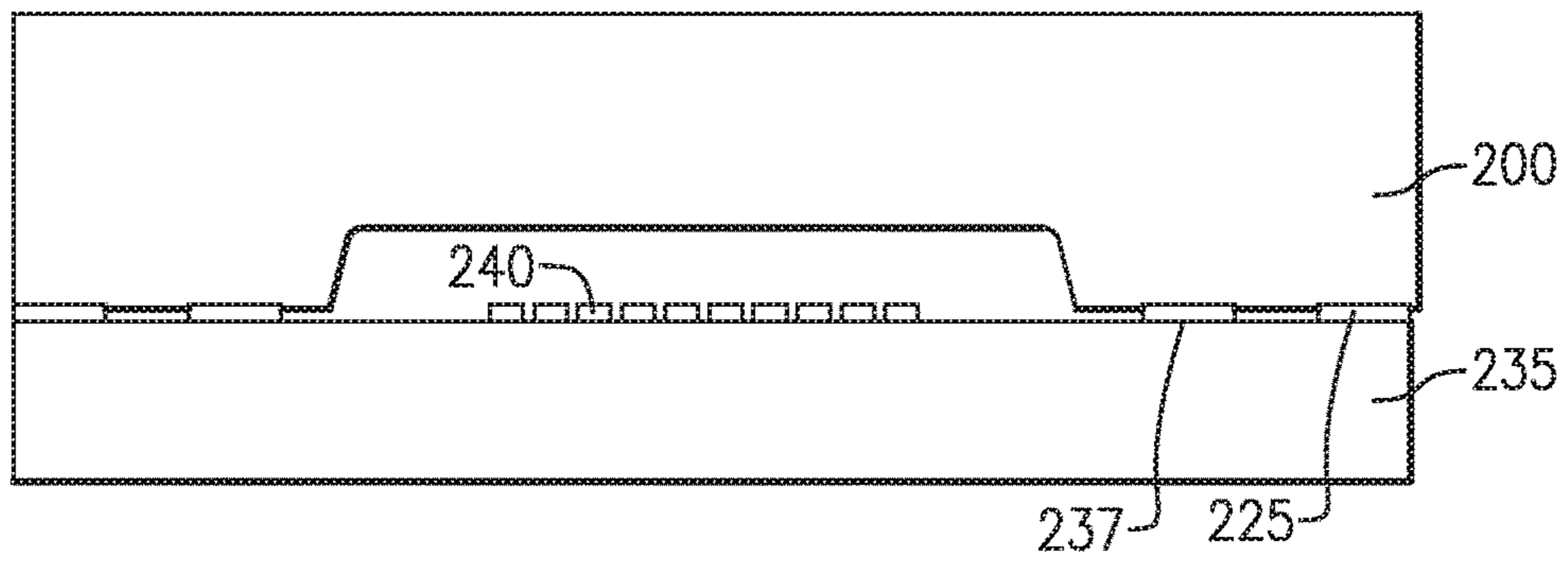

FIG.10B

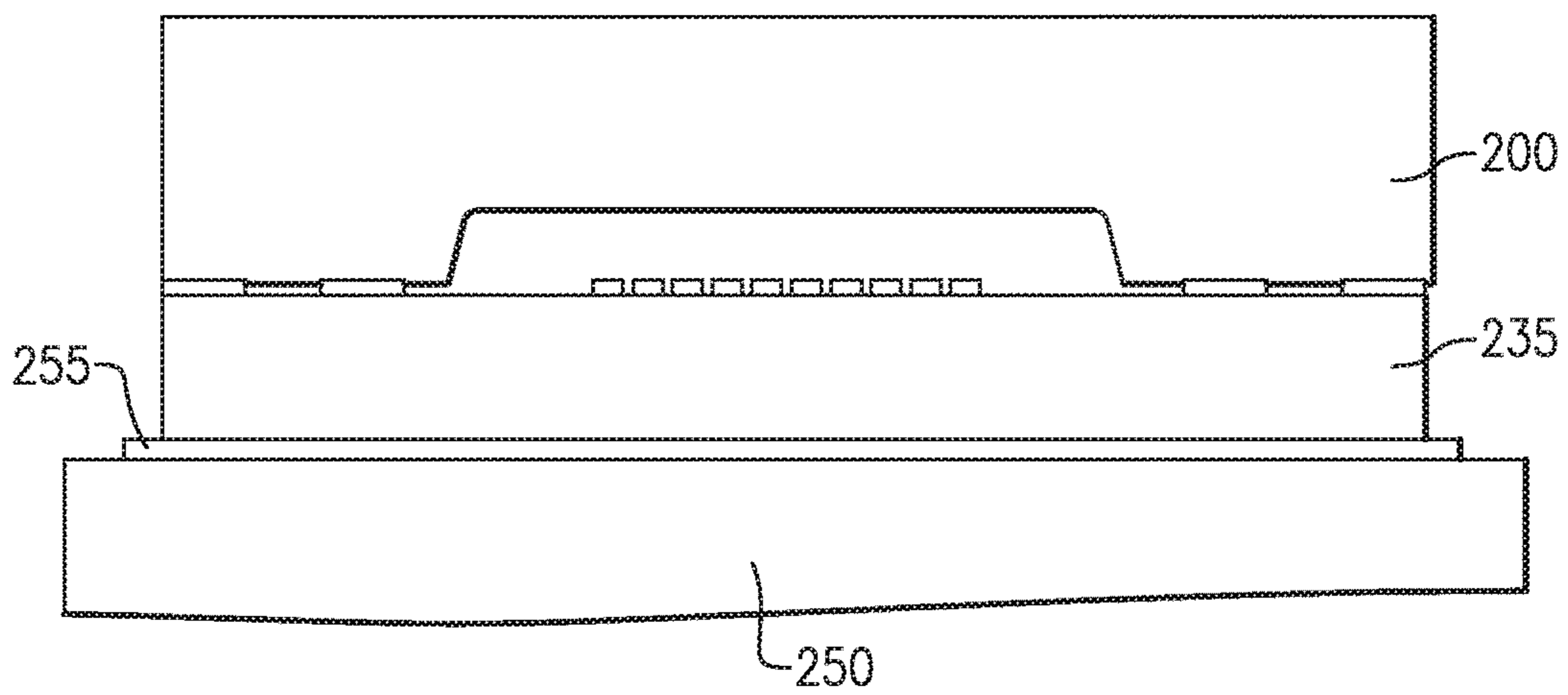

FIG.10C

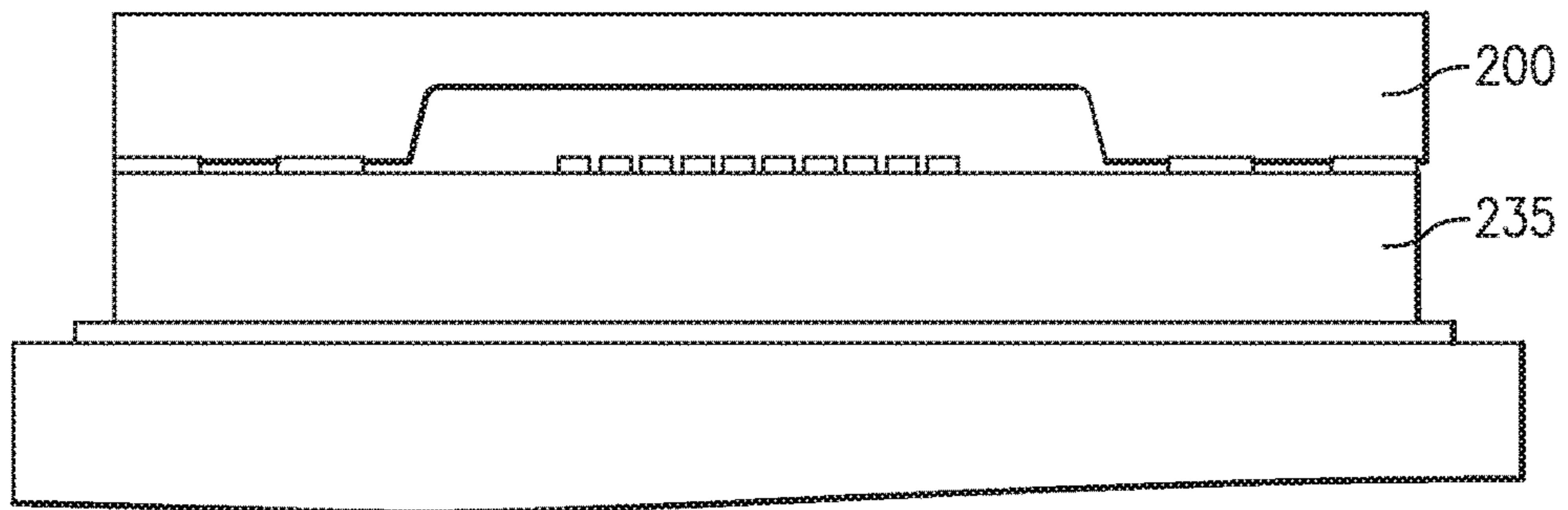

FIG. 10D

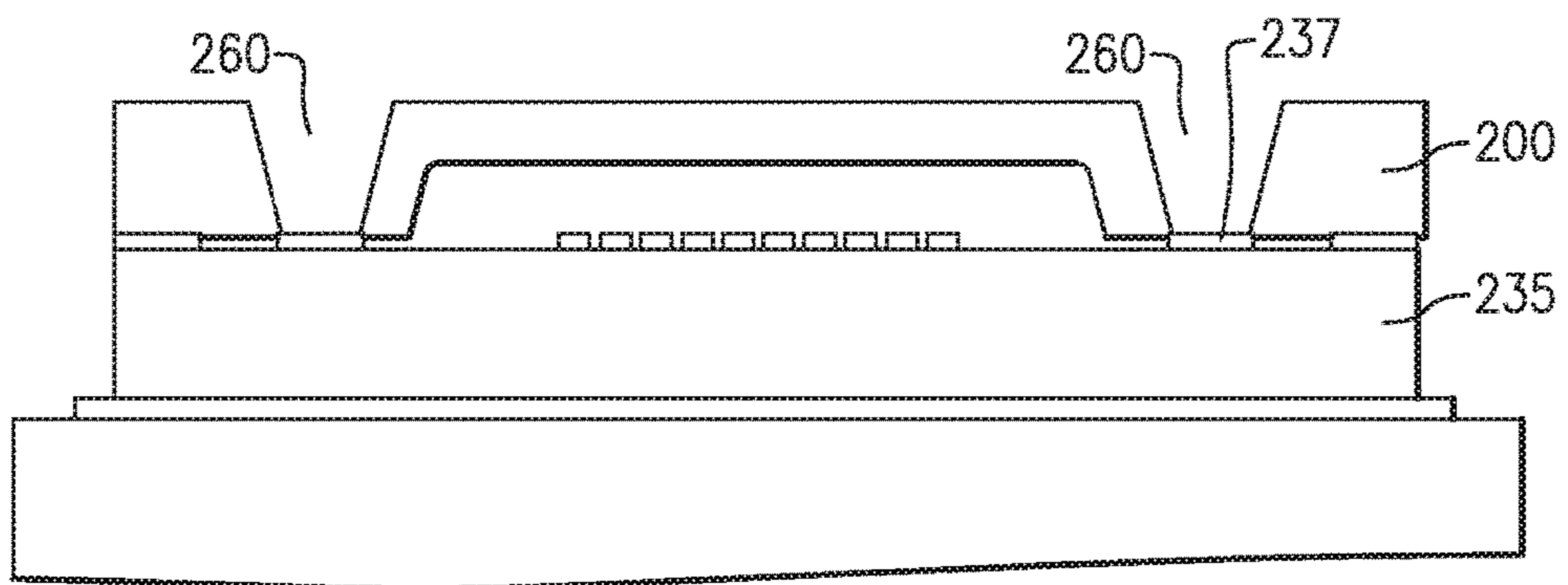

FIG. 10E

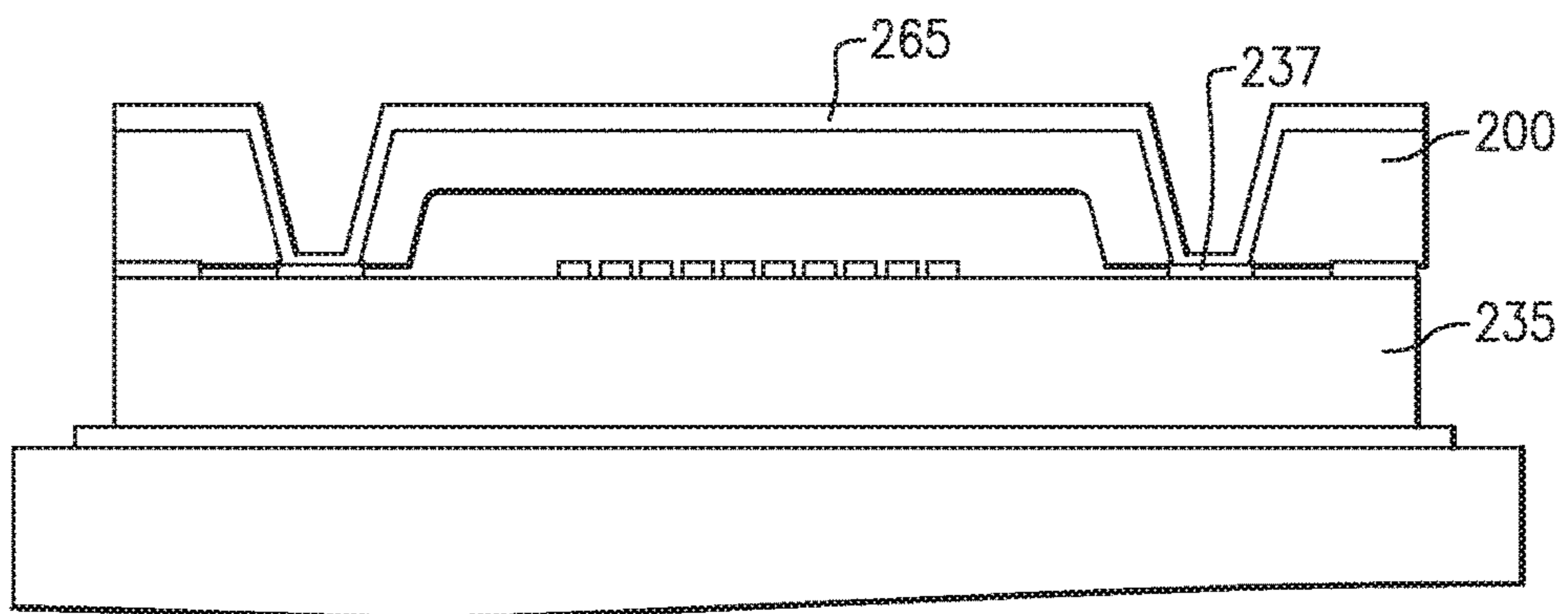

FIG. 10F

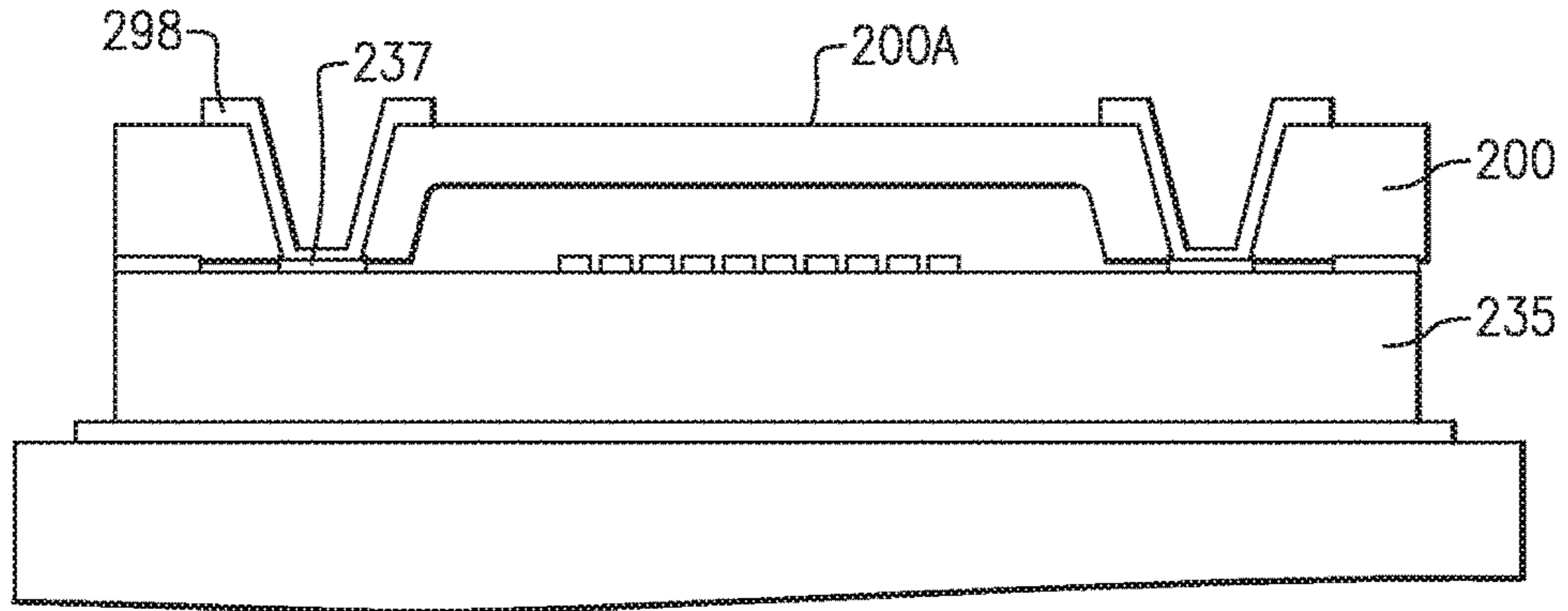

FIG. 10G

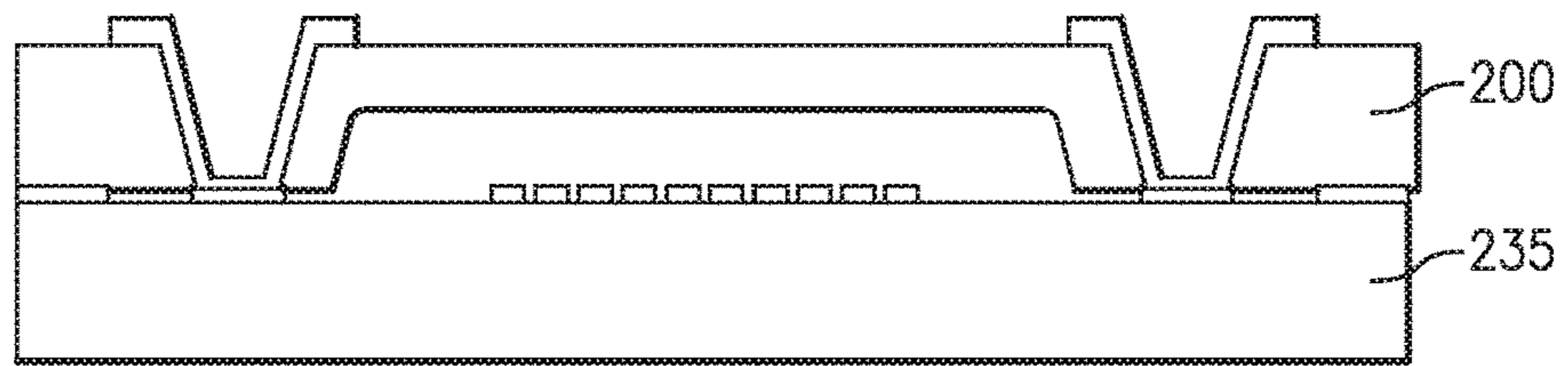

FIG. 10H

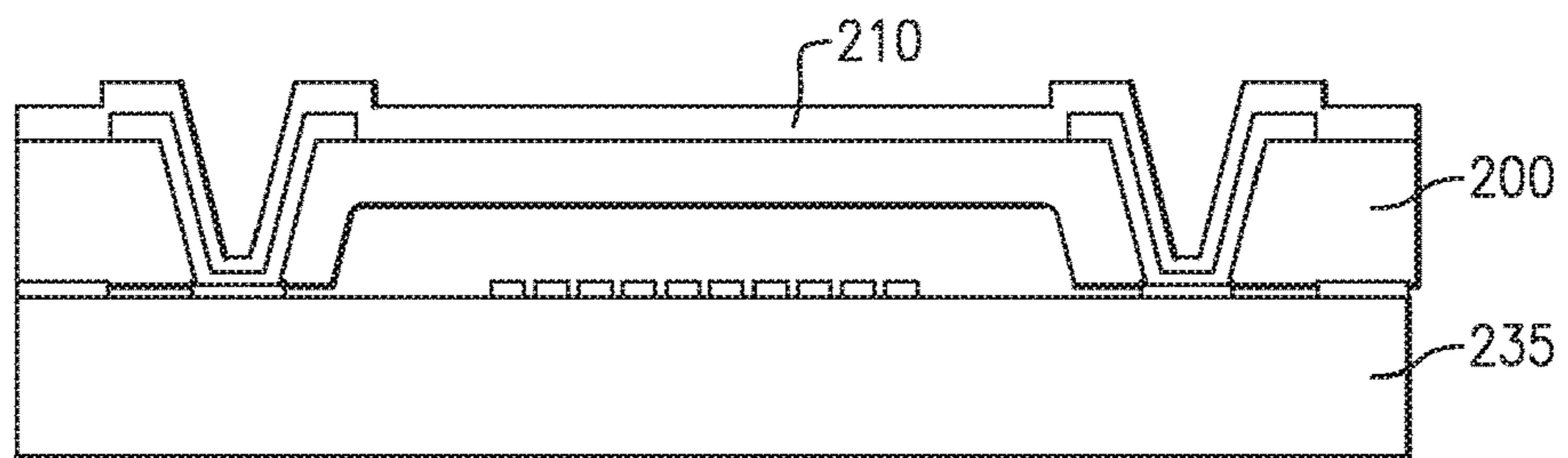

FIG. 10I

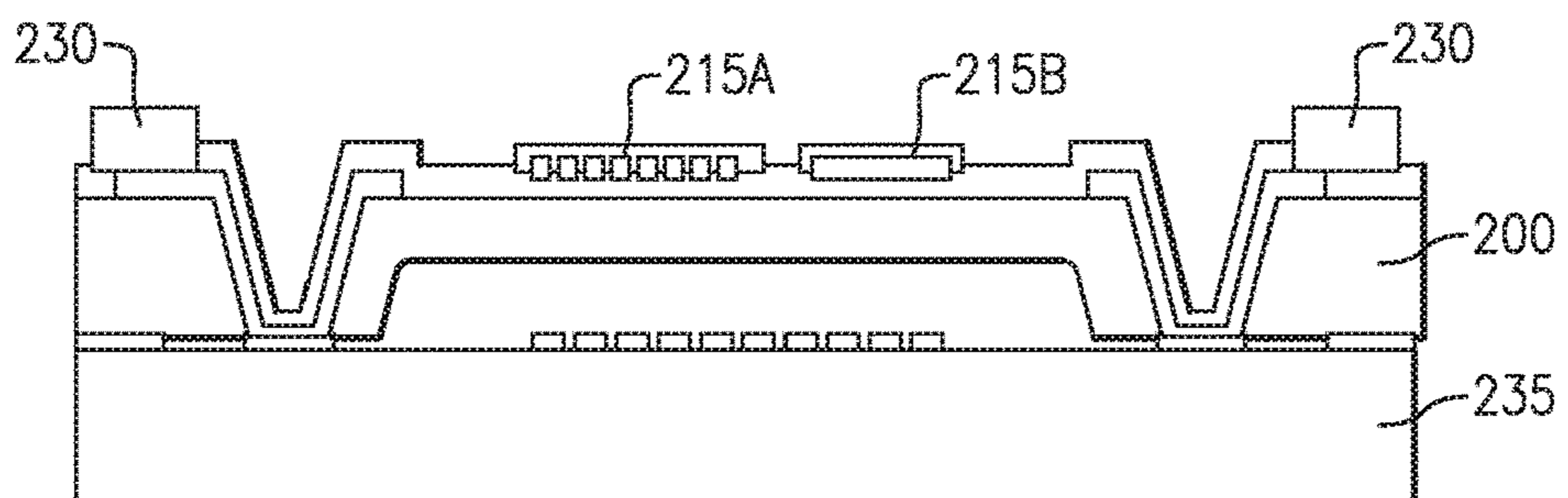

FIG. 10J

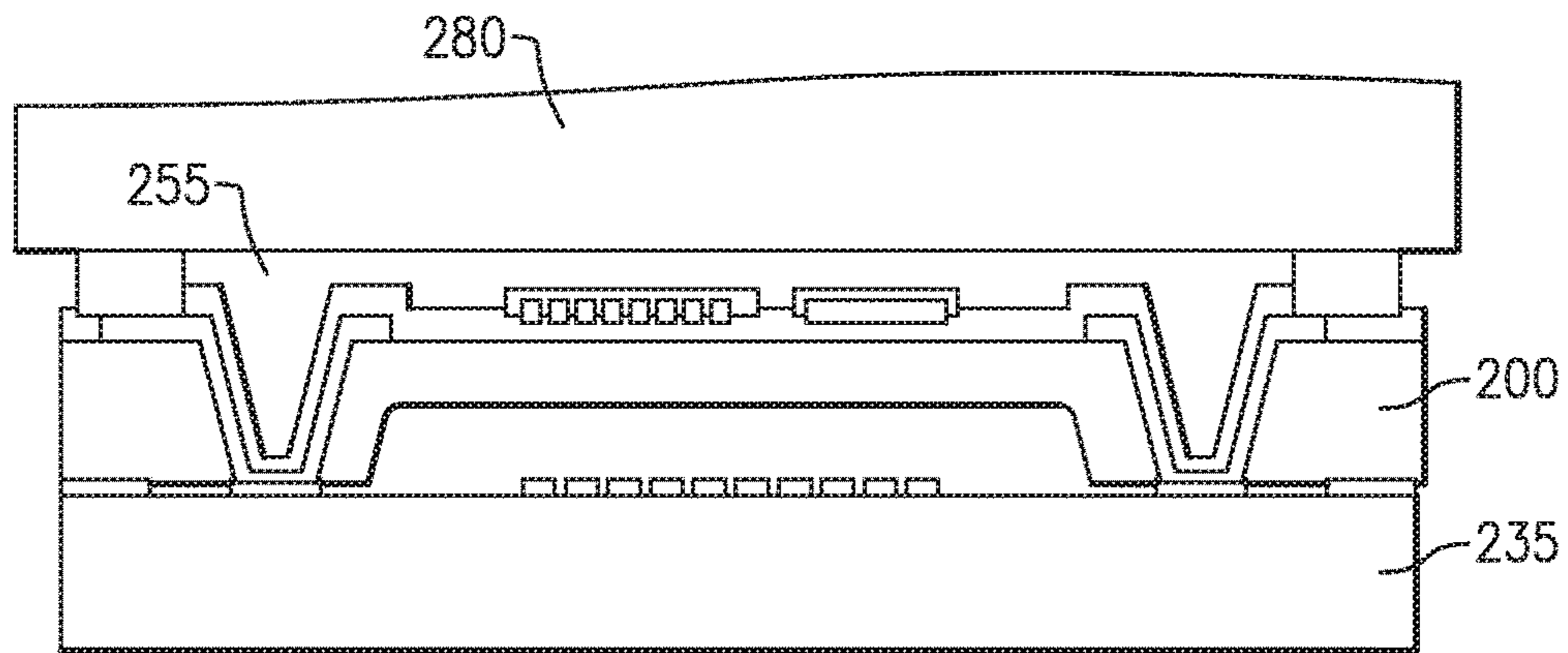

FIG. 10K

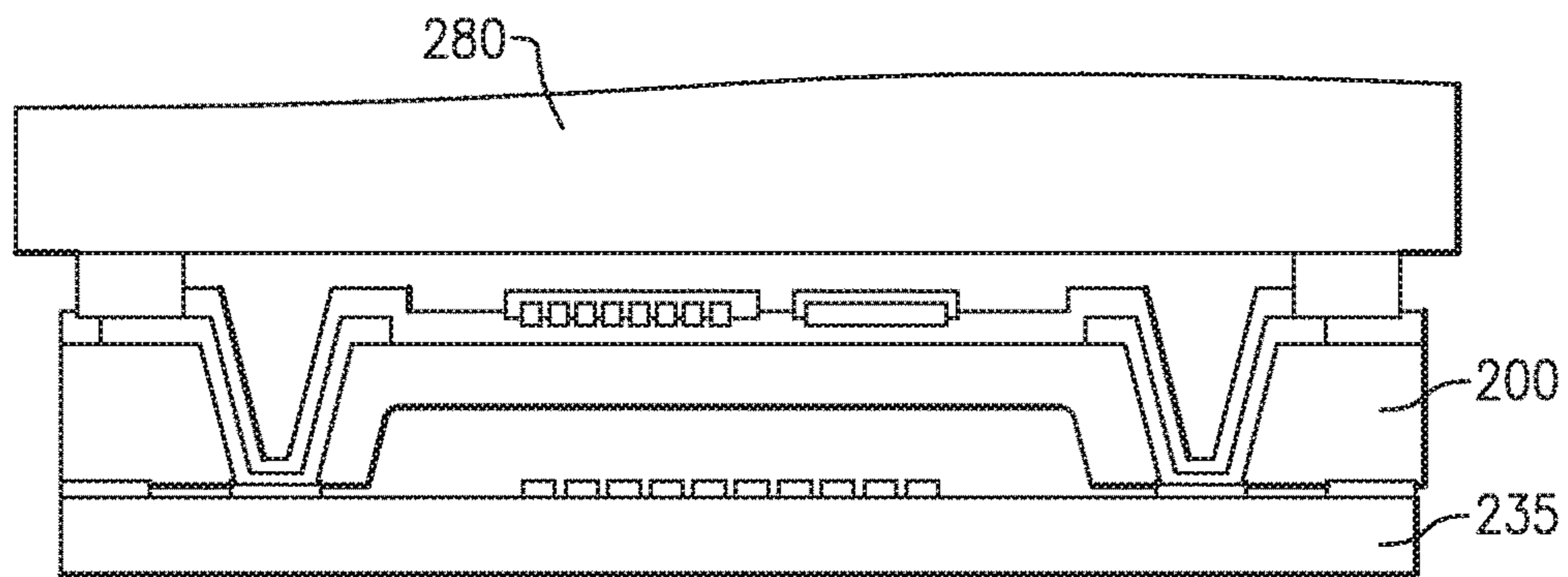

FIG. 10L

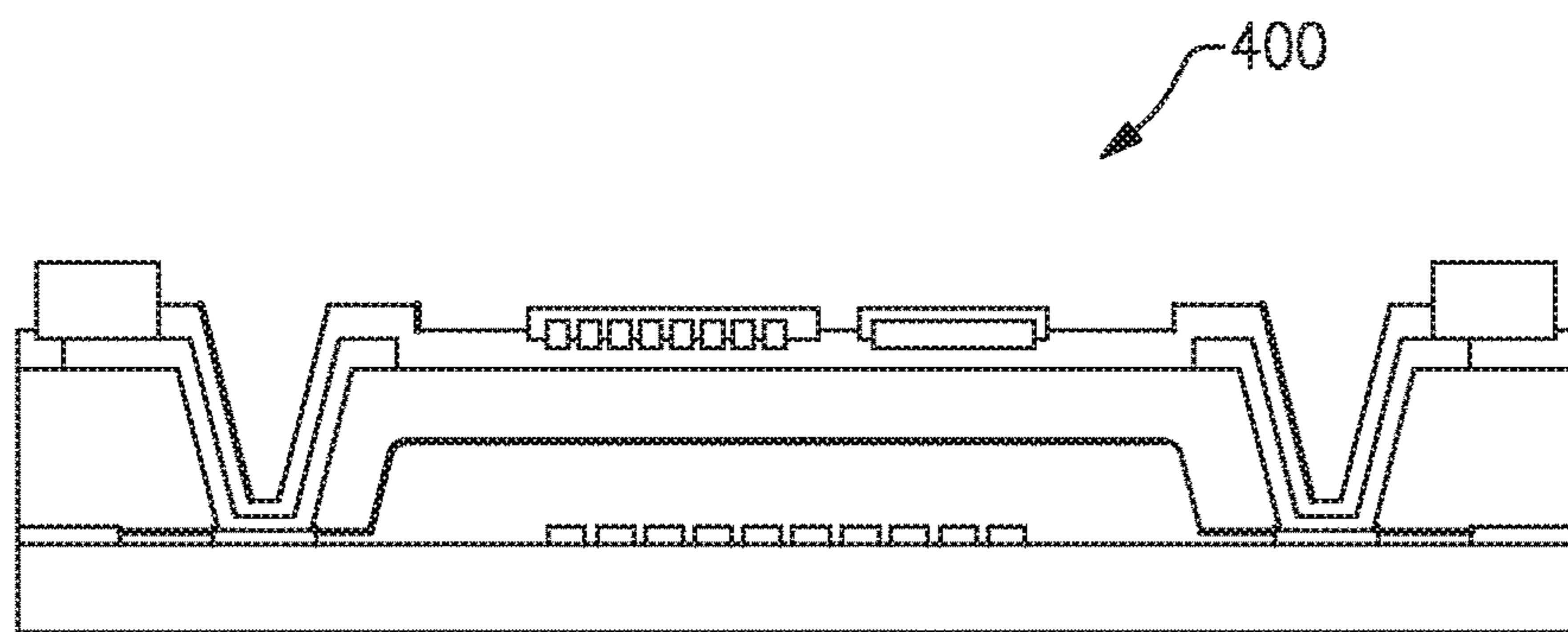
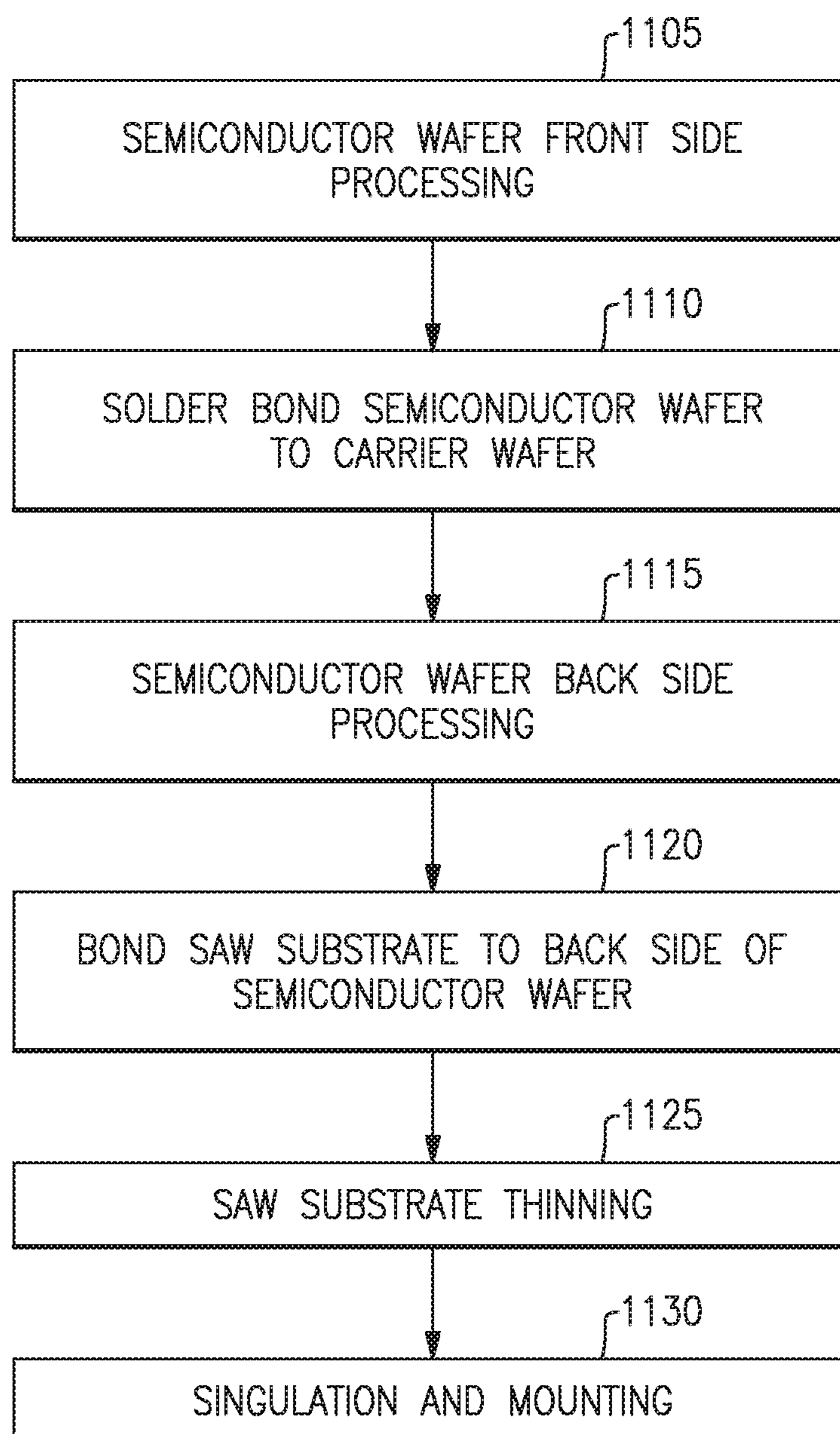

FIG. 10M

**FIG. 11**

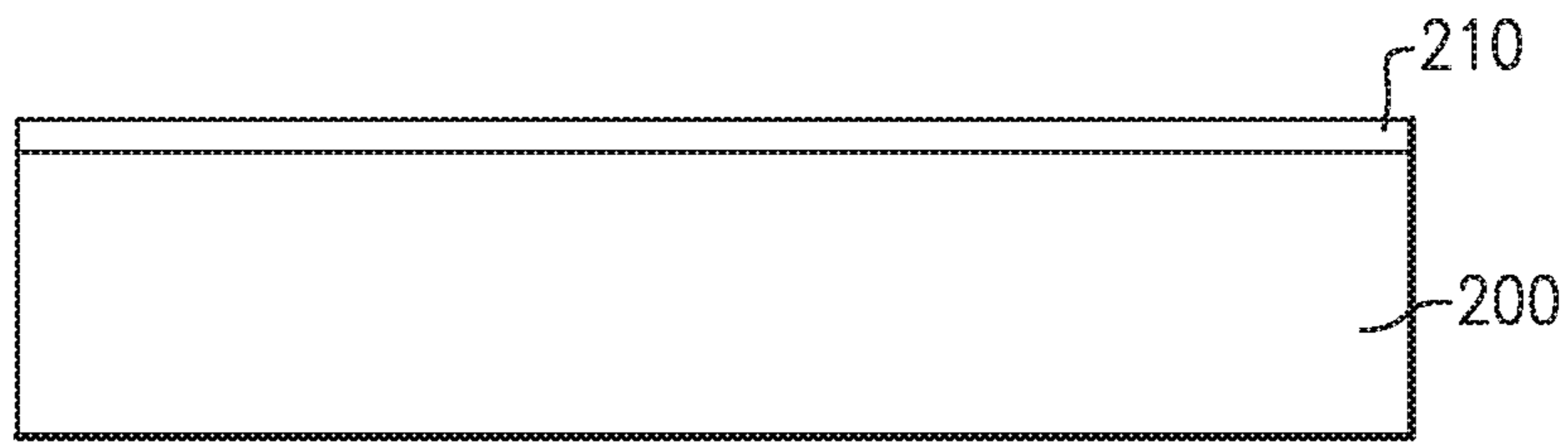

FIG. 12A

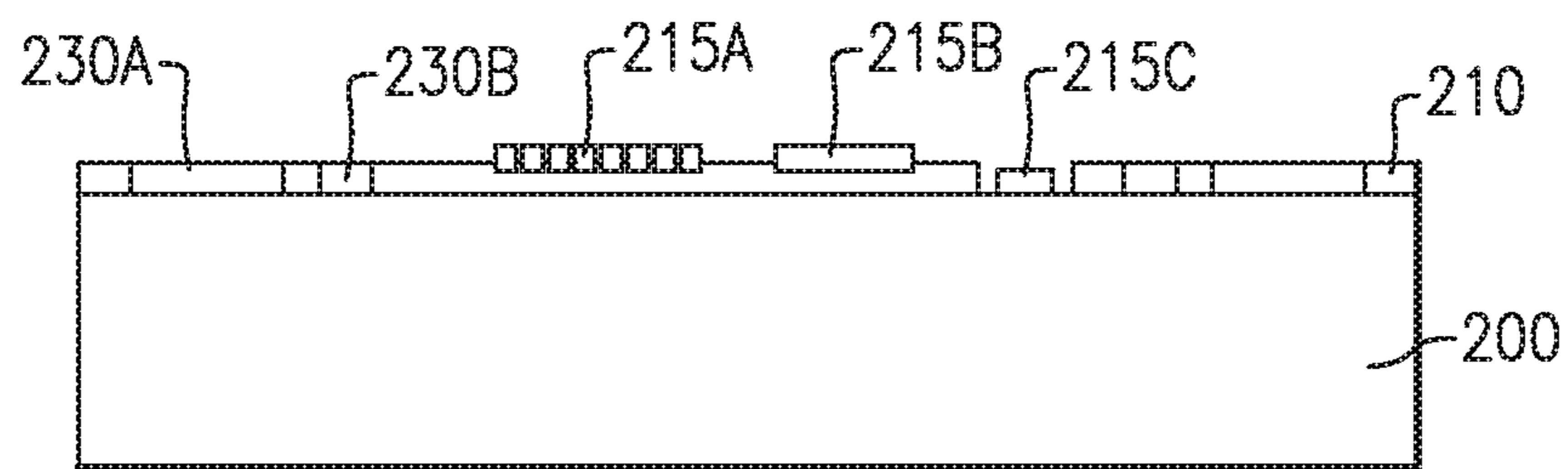

FIG. 12B

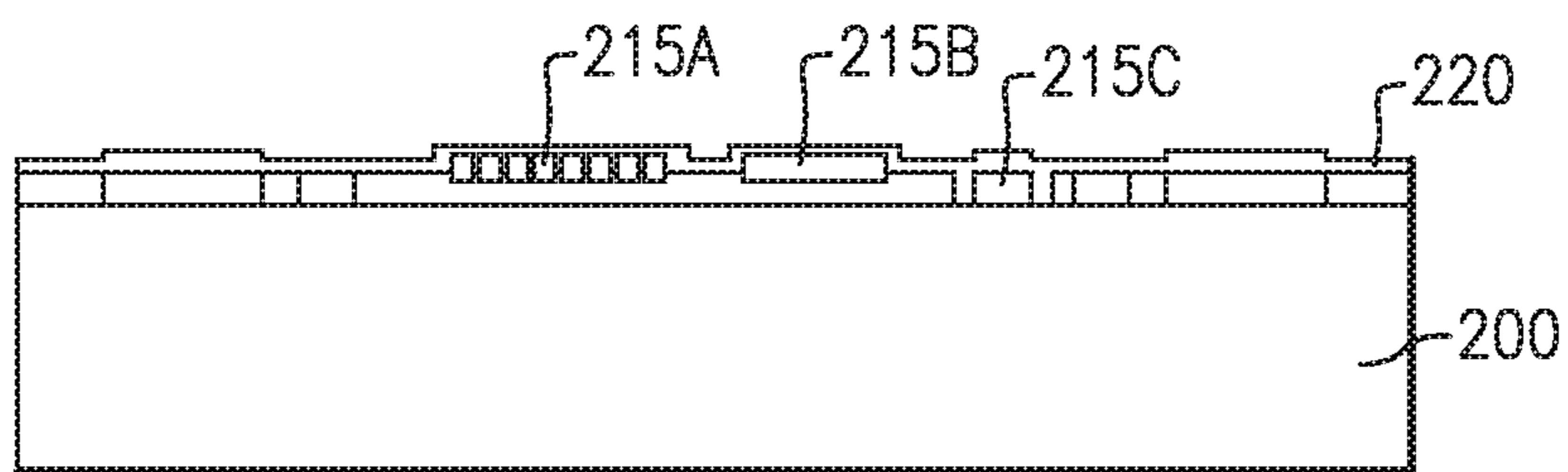

FIG. 12C

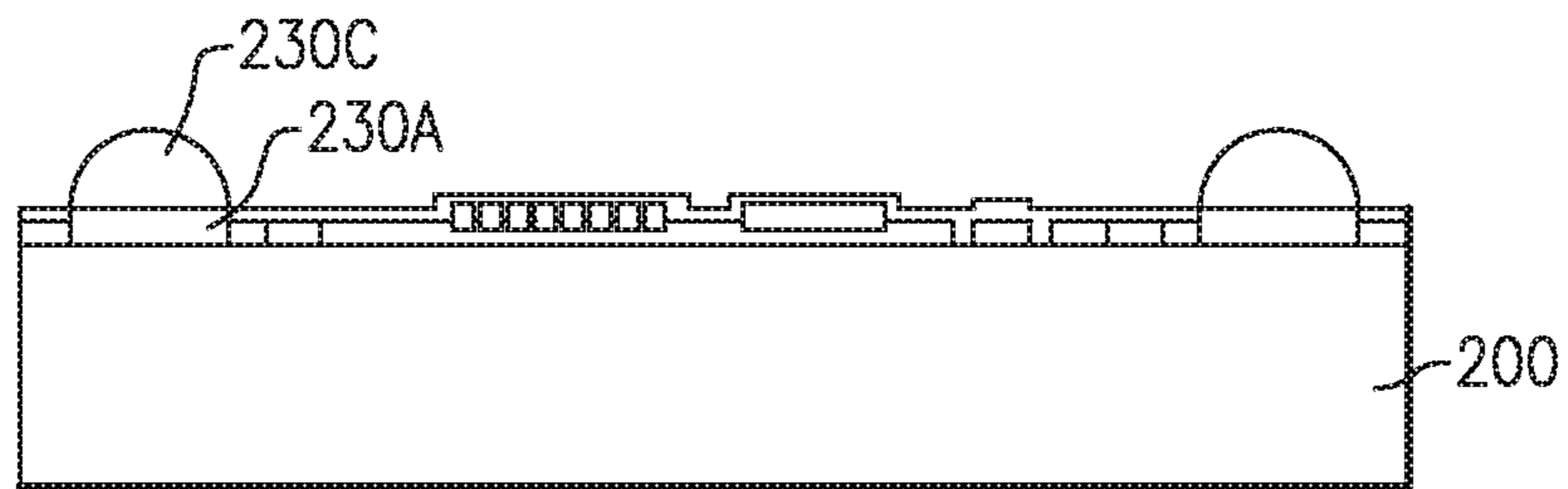

FIG. 12D

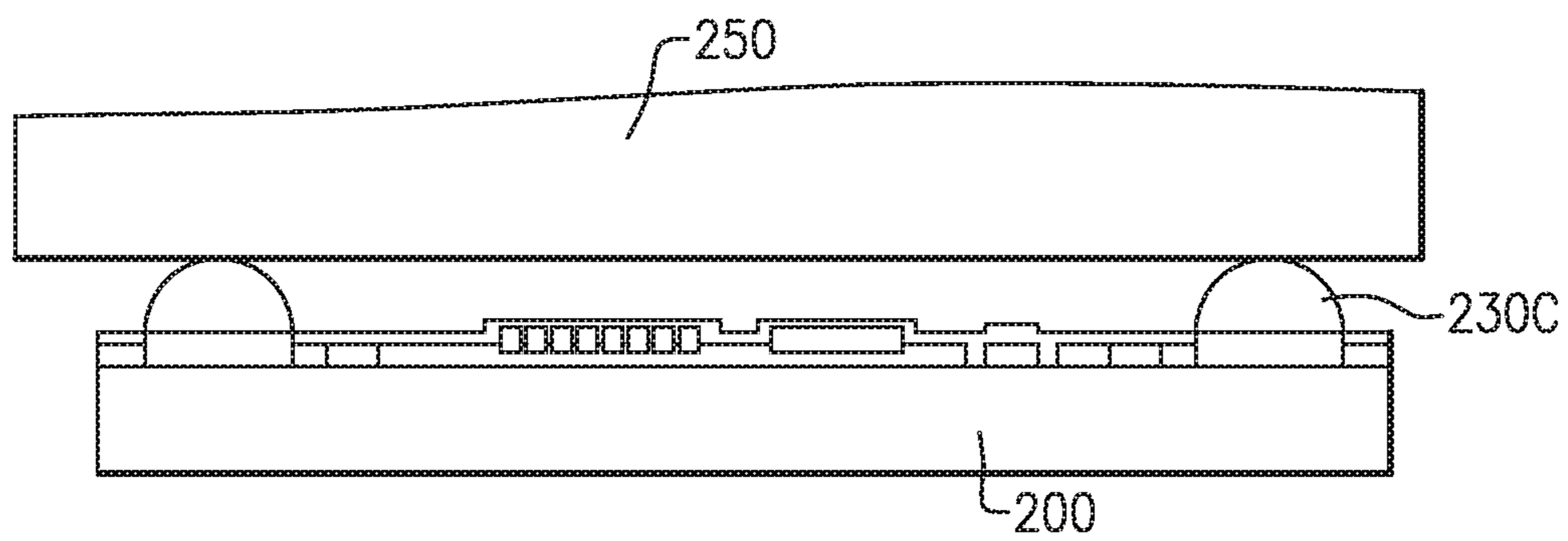

FIG. 12E

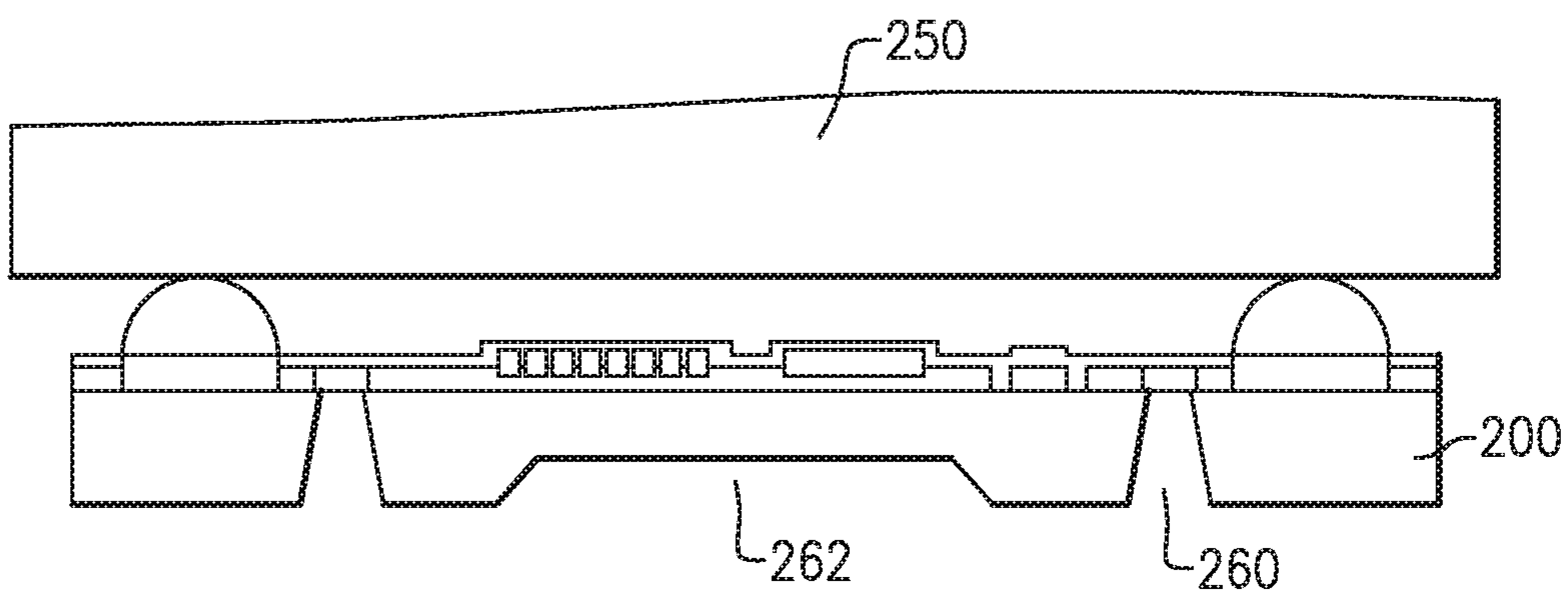

FIG. 12F

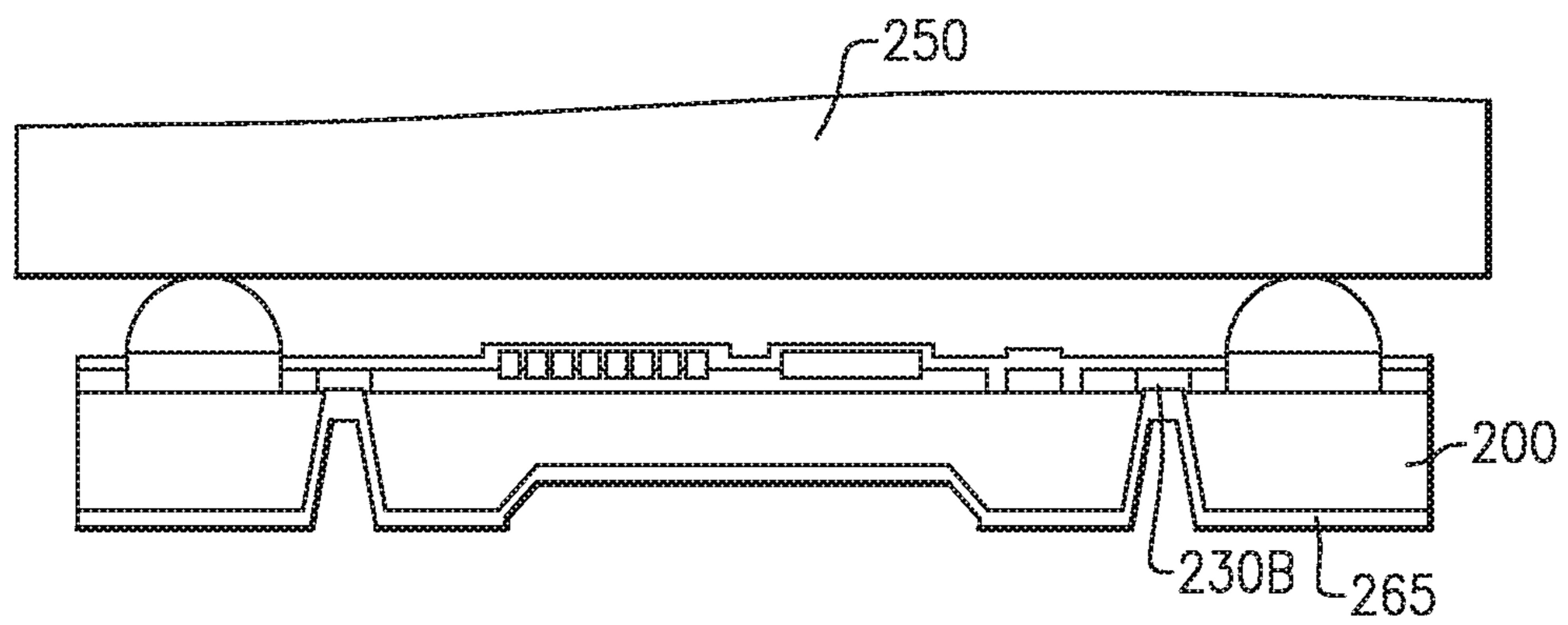

FIG. 12G

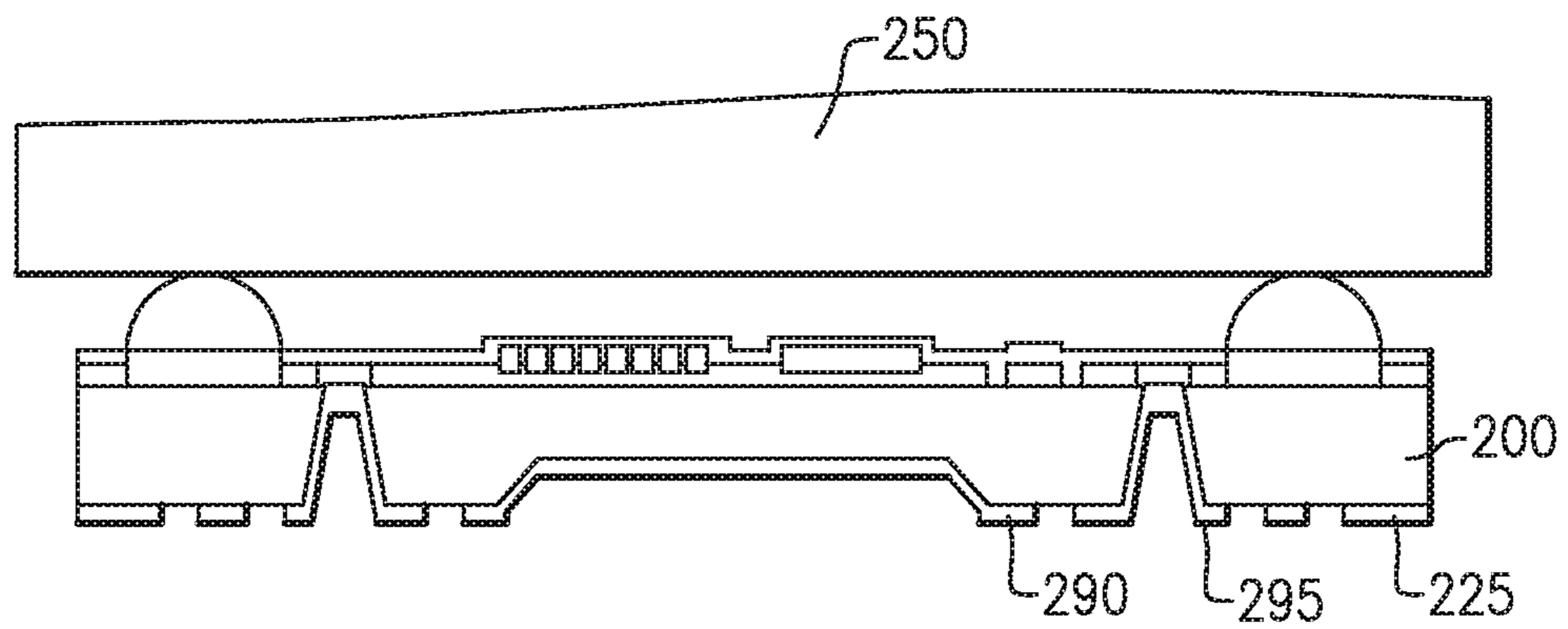

FIG. 12H

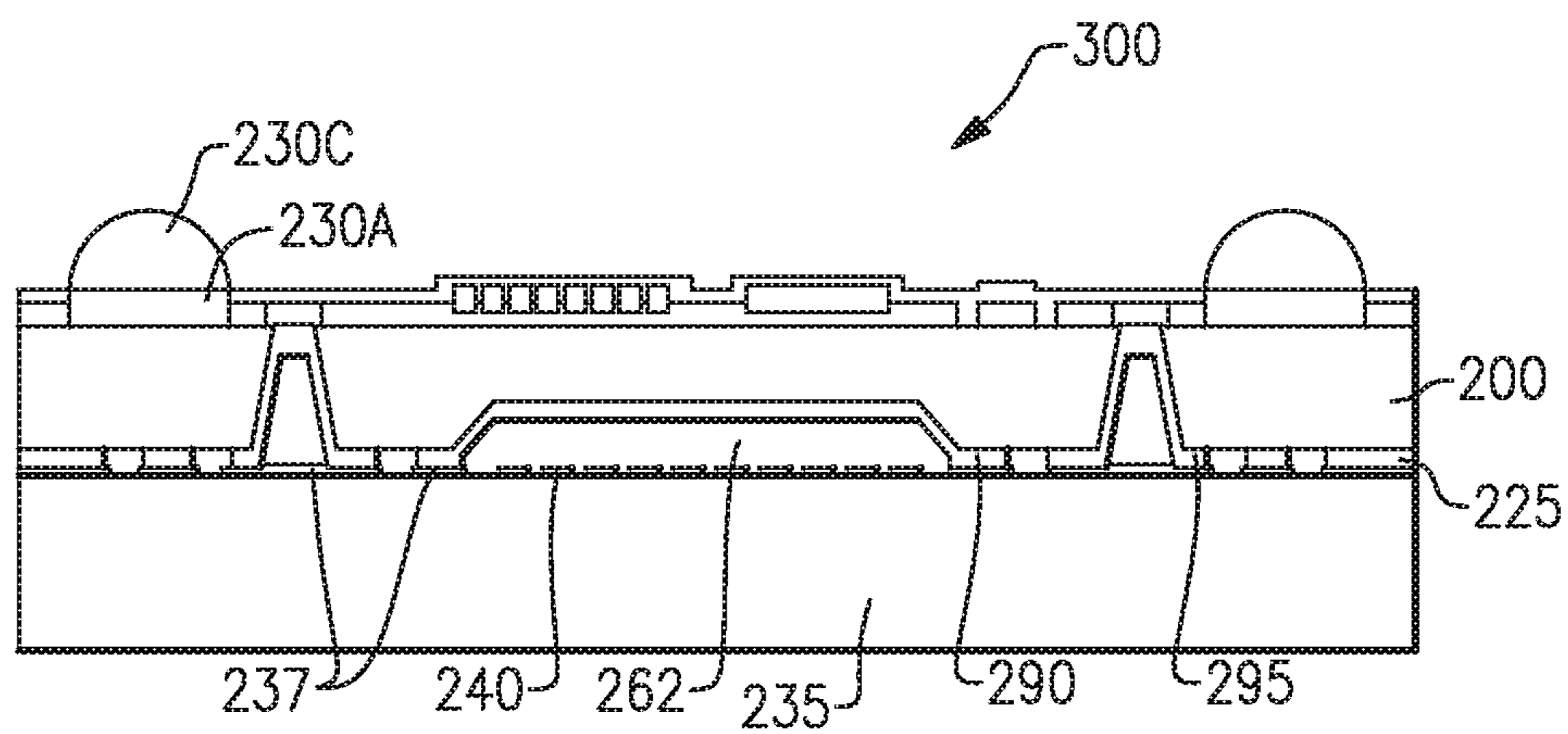

FIG. 121

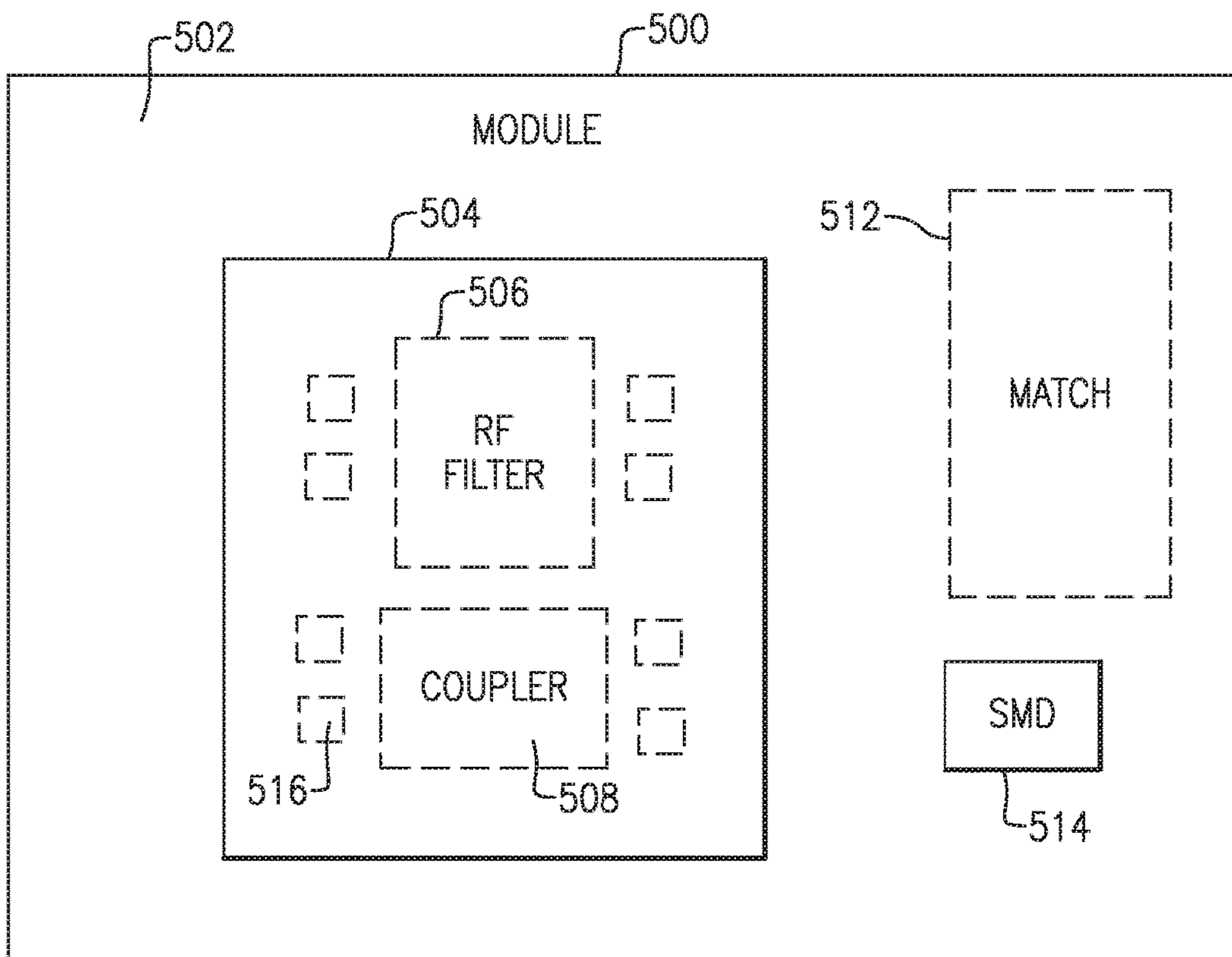

FIG. 13

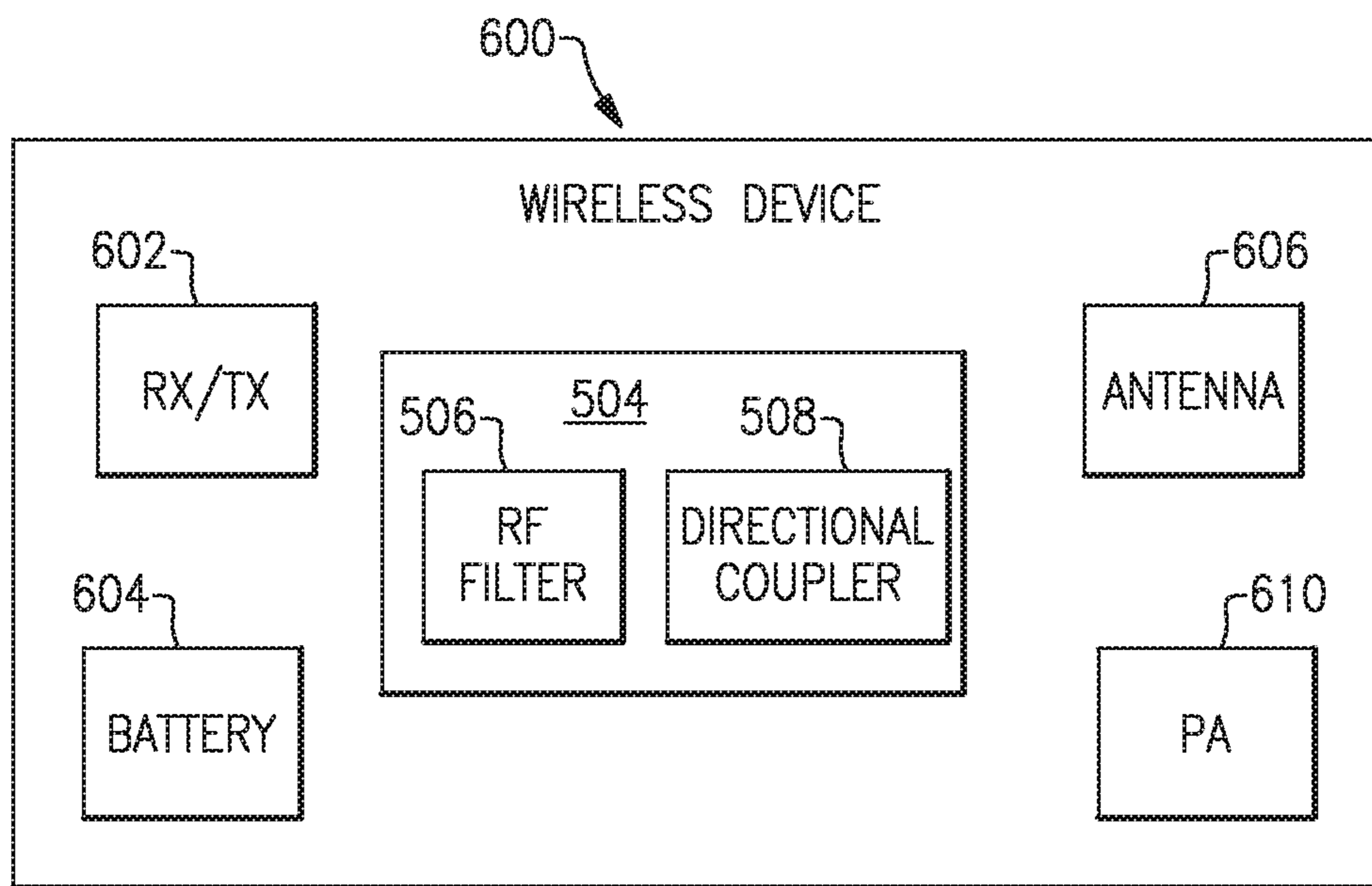

FIG.14

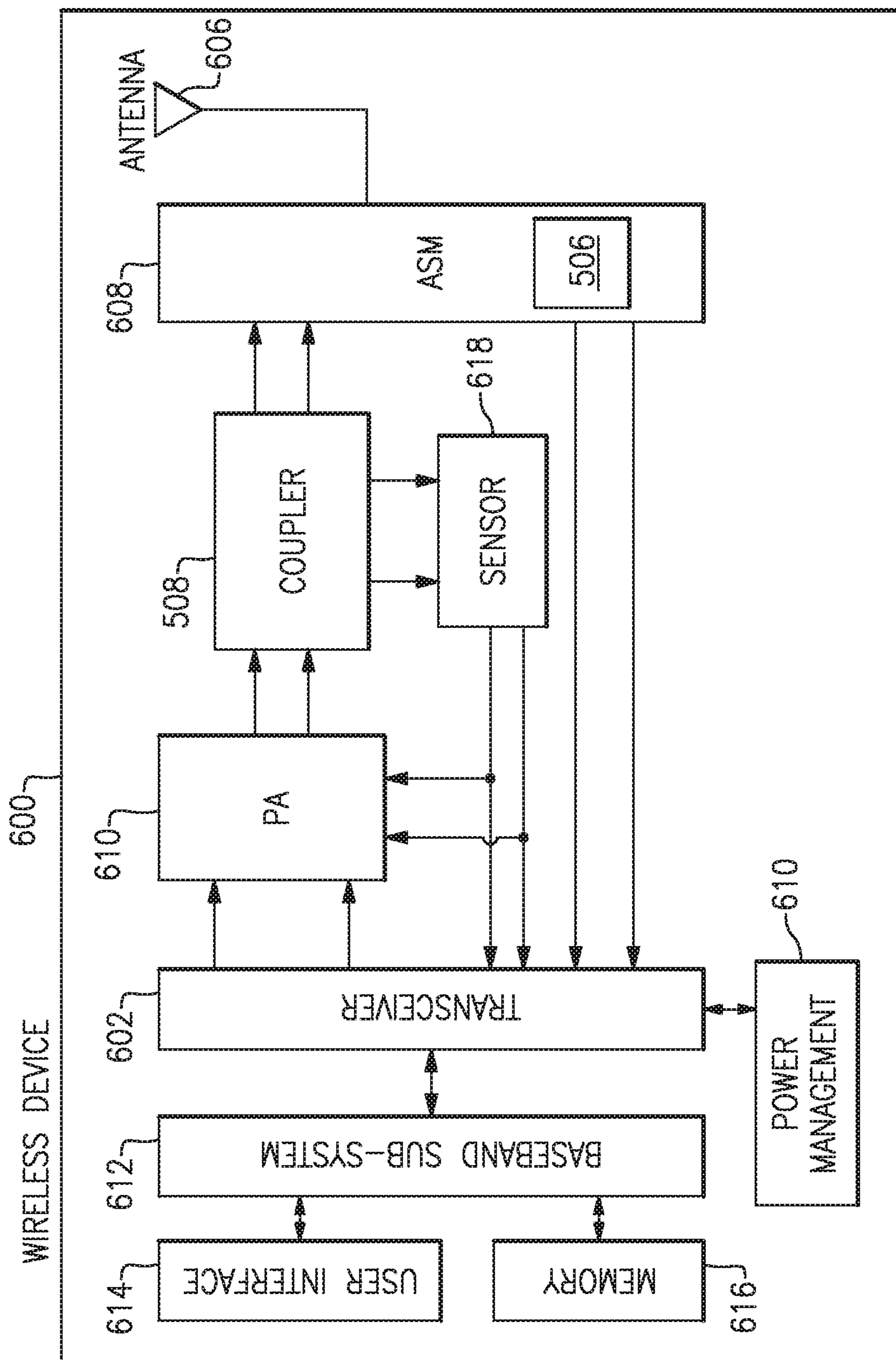

FIG.15

1

**WAFER LEVEL CHIP SCALE FILTER
PACKAGING USING SEMICONDUCTOR
WAFERS WITH THROUGH WAFER VIAS**

CROSS REFERENCE TO RELATED
APPLICATIONS

This application claims priority under 35 USC § 119(e) to U.S. provisional patent application Ser. No. 62/475,386, titled "WAFER LEVEL CHIP SCALE FILTER PACKAGING USING SEMICONDUCTOR WAFERS WITH THROUGH WAFER VIAS," filed Mar. 23, 2017, which is incorporated by reference herein in its entirety for all purposes.

BACKGROUND

Field of Invention

The present invention relates generally to wafer-level chip-scale packages (WLCSP) and flip-chip designs including both semiconductor devices formed on semiconductor substrates and microelectromechanical systems devices formed on piezoelectric substrates.

Discussion of Related Art

Integrated circuits including, for example, transistors and passive devices are typically formed on semiconductor substrates. If a particular implementation calls for both semiconductor integrated circuit devices and microelectromechanical system devices, for example, surface acoustic wave (SAW) filters or bulk acoustic wave (BAW) filters, these filter elements are typically formed on a piezoelectric substrate separate from a semiconductor substrate on which the semiconductor integrated circuit devices are formed.

SUMMARY OF INVENTION

According to one aspect of the present disclosure there is provided an electronics package. The electronics package comprises a semiconductor substrate having one or more passive devices formed thereon and a cavity defined in a first surface thereof. A piezoelectric substrate is bonded to the semiconductor substrate and has a radio frequency (RF) filter formed thereon. The RF filter is disposed within the cavity defined in the semiconductor substrate.

In some embodiments, the one or more passive devices are disposed within the cavity.

In some embodiments, the RF filter is one of a surface acoustic wave filter and a bulk acoustic wave filter.

In some embodiments, the semiconductor substrate includes a plurality of bond pads formed on a second surface thereof.

In some embodiments, the piezoelectric substrate includes one or more bond pads electrically connected to one or more of the plurality of bond pads formed on the second surface of the semiconductor substrate.

In some embodiments, the one or more bond pads of the piezoelectric substrate are electrically connected to the one or more of the plurality of bond pads formed on the second surface of the semiconductor substrate by through-wafer vias passing through the semiconductor substrate.

In some embodiments, the package is configured as a flip-chip package.

In some embodiments, the one or more passive devices are disposed on a second surface of the semiconductor

2

substrate opposite the first surface. The semiconductor substrate may include a plurality of bond pads formed on the second surface thereof.

In some embodiments, the package further includes a seal ring hermetically sealing the cavity.

In some embodiments, side walls and an upper wall of the cavity are coated with a metal film.

In some embodiments, the semiconductor substrate is free of microelectromechanical system (MEMS) devices.

In some embodiments, the package further comprises a passivation film disposed on the semiconductor substrate and one or more passive devices.

In some embodiments, a module for an electronic device includes the electronics package. In some embodiments, an electronic device includes the module.

In accordance with another aspect, there is provided a method of fabricating an electronics package. The method comprises forming a cavity in a first surface of a semiconductor substrate, forming one or more passive devices on the semiconductor substrate, forming a radio frequency (RF) filter on a piezoelectric substrate, and bonding the semiconductor substrate to the piezoelectric substrate with the RF filter disposed within the cavity.

In some embodiments, the one or more passive devices are formed within the cavity.

In some embodiments, the one or more passive devices are formed on a second surface of the semiconductor wafer opposite the first surface.

In some embodiments, the method further comprises forming bond pads for connection to a mounting substrate on the second surface of the semiconductor wafer.

In some embodiments, the method further comprises hermetically sealing the cavity with a metallic seal ring.

In some embodiments, the method comprises bonding the semiconductor substrate to the piezoelectric substrate with a transient liquid phase bond.

BRIEF DESCRIPTION OF DRAWINGS

Various aspects of at least one embodiment are discussed below with reference to the accompanying drawings. In the drawings, which are not intended to be drawn to scale, each identical or nearly identical component that is illustrated in various drawings is represented by a like numeral. For purposes of clarity, not every component may be labeled in every drawing. The drawings are provided for the purposes of illustration and explanation, and are not intended as a definition of the limits of the invention. In the drawings:

FIG. 1A is a flowchart of a method of fabricating a combined semiconductor/piezoelectric substrate package;

FIG. 1B is a flowchart of another method of fabricating a combined semiconductor/piezoelectric substrate package;

FIGS. 2A-2L illustrate the acts in the method of FIG. 1B;

FIG. 3 is a flowchart of a method of fabricating another combined semiconductor/piezoelectric substrate package;

FIGS. 4A-4D illustrate the acts in the method of FIG. 3;

FIG. 5 is a flowchart of a method of fabricating another combined semiconductor/piezoelectric substrate package;

FIGS. 6A-6C illustrate the acts in the method of FIG. 5;

FIG. 7 is a flowchart of a method of fabricating another combined semiconductor/piezoelectric substrate package;

FIGS. 8A-8N illustrate the acts in the method of FIG. 7;

FIG. 9 is a flowchart of a method of fabricating another combined semiconductor/piezoelectric substrate package;

FIGS. 10A-10M illustrate the acts in the method of FIG. 9;

FIG. 11 is a flowchart of a method of fabricating another combined semiconductor/piezoelectric substrate package; FIGS. 12A-12I illustrate the acts in the method of FIG. 11; FIG. 13 illustrates an example of an electronics module; FIG. 14 illustrates an example of a wireless device; and FIG. 15 is a more detailed illustration of the wireless device of FIG. 14.

DETAILED DESCRIPTION

Various aspects and embodiments disclosed herein relate to an improved design for packaging of devices including both semiconductor integrated circuit elements and acoustic wave filter elements. In accordance with some aspects and embodiments a semiconductor substrate including semiconductor integrated circuit elements is bonded to a piezoelectric substrate including acoustic wave filter elements to form a single package. The single package may be formed as a wafer-level chip-scale package (WLCSPP) or as a flip-chip design that may be directly mounted to a printed circuit board or other mounting substrate. Various aspects and embodiments disclosed herein provide for a device package including both semiconductor elements and acoustic wave elements having a reduced size as compared with previous designs.

A high level description of a method of forming a combined semiconductor/piezoelectric substrate package is illustrated in the flowchart of FIG. 1A. The method includes forming a cavity in a first surface of a semiconductor substrate (act 5), forming one or more passive devices on the semiconductor substrate (act 10), forming a radio frequency (RF) filter on a piezoelectric substrate (act 15), and bonding the semiconductor substrate to the piezoelectric substrate with the RF filter disposed within the cavity (act 20). The method may be performed with the various acts performed in various orders and with the one or more passive devices and/or the piezoelectric substrate formed on or bonded to different sides or to the same side of the semiconductor substrate. As the terms are used herein a front side or surface of a wafer or substrate is the side or surface in or on which devices are formed and the rear side or surface of a wafer or substrate is the side or surface opposite the front side or surface.

One particular example of a method of forming a combined semiconductor/piezoelectric substrate package as described in FIG. 1A is illustrated in the flowchart of FIG. 1B and the corresponding FIGS. 2A-2L, illustrating the various process steps. In FIGS. 2A-2L, the formation of a single device package is illustrated. It is to be understood that these figures, as well as the other figures presented herein, illustrate only a small portion of semiconductor and piezoelectric wafers and the method may result in the formation of hundreds or thousands or more of the illustrated devices and packages concurrently prior to singulation into individual device packages. In act 105, processing of a first side (e.g., the front side) of semiconductor substrate is performed. In the front side processing of the semiconductor substrate a cavity 205 is etched into the front side of a portion of a semiconductor wafer 200. The semiconductor wafer 200 may be silicon or gallium arsenide (GaAs) or another form of semiconductor. GaAs may be utilized when fabricating devices that operate at high frequencies, for radiation hardened operation, or for other reasons. The cavity 205 may be etched by wet etching processes known in the art, although in other embodiments dry etching may alternatively be utilized to form the cavity 205. After formation of the cavity 205 a passivation film 210, for example,

silicon nitride (Si_3N_4) or silicon dioxide (SiO_2) is deposited over the front surface of the wafer using, for example, a chemical vapor deposition (CVD) process known in the art. The resultant structure (only a portion of which is shown) is illustrated in FIG. 2A.

Front side processing of the semiconductor substrate further includes forming one or more passive devices 215, for example, inductors, capacitors, transmission lines, couplers, diodes, etc. within the cavity 205 by, for example, deposition and patterning of a metal film or films. The metal film or films may include one or more of copper, aluminum, gold, or other appropriate materials. A passivation film 220, for example, silicon nitride or silicon dioxide may be deposited over the completed passive devices 215. Prior to, subsequent to, or concurrent with formation of the passive devices 215 a seal ring 225 and bond pads 230 are formed on portions of the front side of the wafer 200 outside of the cavity 215. The seal ring 225 and bond pads 230 may contact the semiconductor material of the wafer 200 or electrical traces formed thereon through the passivation film 210 and may be formed of one or more of copper, aluminum, gold, or other appropriate materials. The bond pads 230 may be electrically connected to one or more of the passive devices 215. The resultant structure is illustrated in FIG. 2B.

In act 110 (FIG. 2C), a piezoelectric substrate 235 (or SAW wafer) on which microelectromechanical device(s) 240, for example, surface acoustic wave (SAW) filters, bulk acoustic wave (BAW) filters, duplexers, etc. were previously formed is bonded to the seal ring 225 and bond pads 230 of the wafer 200 such that the front surface of the piezoelectric substrate 235, including the microelectromechanical devices 240 faces the front or cavity side of the wafer 200. The piezoelectric substrate 235 may be formed of, for example, lithium tantalate (LiTaO_3), lithium niobate (LiNbO_3), or other piezoelectric materials known in the art for fabrication of microelectromechanical devices such as SAW or BAW filters. The piezoelectric substrate 235 may be bonded to the seal ring 225 and bond pads 230 of the wafer 200 with a low temperature eutectic bonding material 245, for example, solder. Additionally or alternatively, the piezoelectric substrate 235 may be bonded to the seal ring 225 and bond pads 230 of the wafer 200 with materials that form a transient liquid phase (TLP) bond, for example, as described in commonly owned and co-pending U.S. patent application Ser. No. 14/815,098, published as US 2016/0037649 A1 on Feb. 4, 2016.

The seal ring 225 and front surfaces of the piezoelectric substrate 235 and semiconductor wafer 200 may define a sealed cavity including the cavity 205, passive devices 215, and microelectromechanical device(s) 240. The bond pads 230 may be electrically and physically coupled to electrical traces (not shown) on the piezoelectric substrate 235 that are in electrical communication with the microelectromechanical device(s) 240.

In act 115 backside processing of the semiconductor wafer 200 is performed. As illustrated in FIG. 2D a carrier wafer 250, for example, a sapphire carrier wafer is bonded to the rear side of the piezoelectric substrate 235 (the side opposite the side having the microelectromechanical device(s) 240). The carrier wafer 250 may be bonded to the piezoelectric substrate 235 with a temporary bonding material 255, for example, a Crystalbond™ adhesive. The semiconductor wafer 200 is thinned, for example, by backside grinding or polishing (FIG. 2E) until it reaches a thickness of between about 3 mils and about 4 mils (between about 75 μm to about 102 μm).

Through-wafer vias (TWVs) **260** are then etched through the rear of the thinned wafer **200** to expose lower surfaces of the bond pads **230** (FIG. 2F). A layer of metal **265**, for example, copper or aluminum, is deposited on the rear of the thinned wafer and lower surfaces of the bond pads **230** (FIG. 2G) and then patterned to create passive device bonding pads **270** that are in electrical communication with the passive device(s) **215** through conductors (e.g., TWVs, not shown) extending through the bulk of the semiconductor wafer **200** (FIG. 2H). Portions of the metal layer **265** in electrical contact with the bond pads **230** may extend onto the rear of the wafer **200** to form electrical contacts **275** for the microelectromechanical device(s) **240** on the piezoelectric substrate **235**. The carrier wafer **250** is then removed from the rear side of the piezoelectric substrate **235** by, for example, dissolving the temporary bonding material **255** in a solvent, for example, acetone (FIG. 2I).

Thinning of the piezoelectric substrate **235** is performed in act **120**. A carrier wafer **280**, which may be substantially similar or even the same wafer as carrier wafer **250** is bonded to the rear side of the semiconductor wafer with temporary bonding material **255** (FIG. 2J). The piezoelectric substrate **235** is then thinned, for example, by backside grinding or polishing until it is between about 200 μm and about 250 μm thick. The carrier wafer **280** is then removed from the wafer **200**, for example, by dissolution of the temporary bonding material **255** in a solvent, for example, acetone (FIG. 2K).

Singulation and mounting of the completed combined semiconductor/piezoelectric substrate package is then performed in act **125**. The completed semiconductor/piezoelectric substrate package **285** is separated from other semiconductor/piezoelectric substrate packages **285** on the semiconductor wafer and piezoelectric substrate on which they were formed by tape mounting and singulation by, for example, laser dicing or sawing, and then mounted onto a mounting substrate **290**, for example, a printed circuit board by pick and place onto substrate bond pads (not shown) and solder reflow or transient liquid phase bonding. The mounted packages **285** may then be overmolded with a molding compound **295**, for example, epoxy for protection from the environment, resulting in the structure illustrated in FIG. 2L.

An advantage of the process described above is that it is fully compatible with existing GaAs heterojunction bipolar transistor (HBT) technology in that it may be performed using the same types of equipment used in existing GaAs HBT fabrication technologies. The metal seal rings **225** may provide a hermetic seal for the cavity **215** and the microelectromechanical device(s) **240** disposed therein. The process provides for fabrication of a SAW or BAW filter or a circuit including same along with passive components to provide filter impedance matching within a single package. Utilization of the carrier wafers **250**, **280** provides for the package to be produced while avoiding the need for the handling of thin, fragile wafers. The TWVs **260** provide low impedance and low inductance connections to the microelectromechanical device(s) **240** on the piezoelectric substrate **235**. The package **285** may exhibit high mechanical integrity, may be as thin as about 350 μm or less, and may be less expensive to produce than processes involving separately forming semiconductor circuit elements and microelectromechanical device(s) on a corresponding piezoelectric substrate.

Various modifications may be made to the process described above. In one embodiment, backside processing of the semiconductor wafer **200** may be performed prior to

bonding of the semiconductor wafer **200** to the piezoelectric substrate **235**. This modification is illustrated with reference to the flowchart of FIG. 3 and the diagrams in FIGS. 4A-4D. In this embodiment, the cavity **205**, passive components **215**, seal ring **225**, and bond pads **230** are formed in a similar manner as in the process described above (collectively Semiconductor Wafer Front Side Processing act **305** in FIG. 3). However, instead of bonding the piezoelectric substrate **235** to the semiconductor wafer **200** as in act **110**, FIG. 2C, back side processing of the semiconductor wafer **200** is first performed (act **310**). A carrier wafer **250** (e.g., a sapphire wafer) may be bonded directly to the front side of the semiconductor wafer **200** with a temporary bonding material **255**, for example, a Crystalbond™ adhesive. The semiconductor wafer **200** may then undergo backside processing similar to that described with reference to act **115** of FIG. 1B, FIGS. 2E-2H to thin the semiconductor wafer **200** and form the TWVs **160** and passive device and microelectromechanical device bond pads **270** and **275** (FIG. 4A). The carrier wafer **250** may be removed from the semiconductor wafer (FIG. 4B), for example, by dissolution of the temporary bonding material **255** with a solvent, for example, acetone.

In act **315**, which is similar to act **110** in the flowchart of FIG. 1B, a piezoelectric substrate **235** having preformed microelectromechanical system device(s) **240**, for example, SAW or BAW filters may be bonded to the seal ring **225** and bond pads **230** of the semiconductor wafer **200** with a low temperature eutectic bonding material **245**, for example, solder or TLP bonding materials. Another carrier wafer **280**, which may be similar or even the same as carrier wafer **250** is then bonded to the rear side of the semiconductor wafer **200** with a temporary bonding material **255** (FIG. 4C). The piezoelectric substrate **235** may then be thinned, for example by backside grinding or polishing in act **320**, which may be similar to act **125** in the flowchart of FIG. 1B. The carrier wafer **280** is then removed from the backside of the semiconductor wafer **200**, for example, by dissolution of the temporary bonding material **255** with a solvent, for example, acetone, resulting in the finished package structure **285** (FIG. 4D) that may be separated from other packaging structures on the semiconductor wafer **200** and piezoelectric substrate **235** and mounted to a mounting substrate in act **325** which may be similar to act **125** of the flowchart of FIG. 1B and FIG. 2L.

The embodiment described with reference to the flowchart of FIG. 3 may have the advantage that the impact of backside processing of the semiconductor wafer **200** on the piezoelectric substrate **235**, for example, mechanical stresses induced during backside grinding or polishing or high temperatures that may be applied during etch of the TWVs **260**, may be minimized.

In another embodiment, described in the flowchart of FIG. 5 and the diagrams in FIGS. 6A-6C, the semiconductor wafer **200** and piezoelectric substrate **235** are separately processed and thinned prior to bonding and singulation. In act **505**, which may be substantially similar to act **305** of the flowchart of FIG. 3, the cavity **205**, passive components **215**, seal ring **225**, and bond pads **230** are formed on the semiconductor wafer **200**. In Semiconductor Wafer Back Side Processing act **510**, which may be substantially similar to act **310** of the flowchart of FIG. 3, a carrier wafer **250** (e.g., a sapphire wafer) is bonded directly to the front side of the semiconductor wafer **200** with a temporary bonding material **255**, for example, a Crystalbond™ adhesive. The semiconductor wafer **200** then undergoes backside processing similar to that described with reference to FIGS. 2E-2H

to thin the semiconductor wafer **200** and form the TWVs **160** and passive device and microelectromechanical device bond pads **270** and **275** (FIG. 6A). The carrier wafer **250** is removed from the semiconductor wafer, for example, by dissolution of the temporary bonding material **255** with a solvent, for example, acetone.

The piezoelectric substrate **235** is separately prepared prior to bonding to the semiconductor wafer **200** (act **515**). A carrier wafer **280** (e.g., a sapphire wafer) is bonded directly to the front side of a piezoelectric substrate **325** having preformed microelectromechanical system device(s) **240**, for example, SAW or BAW filters with a temporary bonding material **255**, for example, a Crystalbond™ adhesive (FIG. 6B). The piezoelectric substrate **235** may then be thinned, for example, by backside grinding or polishing. The carrier wafer **280** is removed from the piezoelectric substrate, for example, by dissolution of the temporary bonding material **255** with a solvent, for example, acetone.

In act **520**, which is similar to act **315** in the flowchart of FIG. 3, the piezoelectric substrate **235** is bonded to the seal ring **225** and bond pads **230** of the thinned semiconductor wafer **200** with a low temperature eutectic bonding material **245**, for example, solder or TLP bonding material. In act **525**, the resulting finished package structure **285** (FIG. 6C) may be separated from other packaging structures on the semiconductor wafer **200** and piezoelectric substrate **235** and mounted to a mounting substrate as described above with reference to act **325** of the flowchart of FIG. 3 and FIG. 2L.

The embodiment described with reference to the flowchart of FIG. 5 may have the advantage that the impact of backside processing of the semiconductor wafer **200** on the piezoelectric substrate **235**, for example, mechanical stresses induced during backside grinding or polishing or high temperatures that may be applied during etch of the TWVs **260**, may be minimized. Further, mechanical stresses that might otherwise be applied to the semiconductor wafer **200** during backside grinding or polishing of the piezoelectric substrate **235** may also be avoided.

In accordance with another aspect, a combination semiconductor wafer/piezoelectric substrate package may be fabricated in which microelectromechanical elements, for example, SAW or BAW filters disposed on the piezoelectric substrate may be disposed or sealed within a cavity formed on the back side of the semiconductor wafer. An example of this process is described with reference to the flowchart of FIG. 7 and the diagrams of FIGS. 8A-8N.

In act **705**, front side processing of a semiconductor substrate is performed. As illustrated in FIG. 8A, the front surface of a semiconductor wafer **200** is passivated by deposition of a layer of, for example, silicon nitride **210** (e.g., by CVD). Devices are formed on the front surface of the semiconductor wafer **200** using fabrication methods known in the art. The devices may include passive devices, for example, inductor(s) **215A**, capacitor(s) **215B**, and/or diodes **215C** (FIG. 8B). The passive devices may be utilized in, for example, a matching circuit for filter elements that are provided on the piezoelectric substrate **235** that will be joined to the semiconductor wafer **200**. The devices formed on the front side of the semiconductor wafer **200** may also include one or more active devices, for example, one or more transistors (not shown). Bond pads may be fabricated on the front side of the semiconductor wafer **200** concurrently with, or before or after fabrication of the devices. The bond pads may include bond pads **230A** that will provide electrical communication with components external to the semiconductor wafer/piezoelectric substrate package and

contacts **230B** that will provide electrical communication between devices formed on the semiconductor wafer **200** and filter elements that are provided on the piezoelectric substrate **235** that will be joined to the semiconductor wafer **200**. Fabrication of the devices on the semiconductor wafer may further include depositing a layer of a passivation film **220**, for example, silicon nitride or silicon dioxide over the fabricated devices (FIG. 8C). Fabrication of the bond pads **230A** may include exposing upper surfaces of the bond pads **230A** or growing the bond pads **230A** above the upper surface of the passivation film **220** (FIG. 8D).

In act **710**, back side processing of the semiconductor wafer **200** is performed. A carrier wafer **250**, for example, a sapphire wafer is bonded to the front side of the semiconductor wafer **200** with a temporary bonding material **255**, for example, a Crystalbond™ adhesive (FIG. 8E). The semiconductor wafer **200** may then undergo a thinning process, for example, backside grinding or polishing to thin the semiconductor wafer **200** to, for example, between about 75 μm and about 100 μm. Through wafer vias **260** are etched (a wet etch or a dry etch or a combination of same) through the back side of the semiconductor wafer **200** to expose lower portions of the contacts **230B**. A backside etch (a wet etch or a dry etch or a combination of same) is also performed to form a back side cavity **262** in the back side of the semiconductor wafer (FIG. 8F).

A layer of metal **265**, for example, copper, aluminum, or another suitable metal or alloy is deposited on the back surface of the semiconductor wafer **200** and makes electrical contact with the bottom of the contacts **230B** (FIG. 8G) and coats the upper and side walls of the cavity **262**. The back side metallization **265** is patterned to form electrical contacts **290** for filter elements that are provided on the piezoelectric substrate **235** that will be joined to the semiconductor wafer **200**, contacts **295** that provide electrical communication between the filter elements that are provided on the piezoelectric substrate **235** and devices on the semiconductor wafer **200** by way of contacts **230B**, and a metal ring **225** (or other closed geometric structure) that will serve as a seal ring to hermetically seal the back side cavity **262** (FIG. 8H). After backside processing of the semiconductor wafer **200**, the carrier wafer **250** may be removed (FIG. 8I), for example, by dissolution of the temporary bonding material **255** with a solvent, for example, acetone.

In act **715** a piezoelectric substrate **235** having preformed microelectromechanical system device(s) **240**, for example, SAW or BAW filters is bonded to the rear side of the semiconductor wafer **200** (FIG. 8J). Electrical contacts **237** on the top of the piezoelectric substrate **235** that are in electrical communication with the microelectromechanical system device(s) **240** may be electrically and physically bonded to the various contacts **290**, **295** on the bottom of the semiconductor wafer **200** with a low temperature eutectic bonding material, for example, solder or TLP bonding material. The seal ring metallization **225** may be bonded to the piezoelectric substrate **235** with a low temperature eutectic bonding material, for example, solder or TLP bonding material and may circumscribe the cavity **262**, forming a hermetic seal for the cavity **262** and microelectromechanical system device(s) **240** disposed within the cavity.

In act **720**, the piezoelectric substrate **235** is thinned. A carrier wafer **280**, for example, a sapphire wafer is bonded to the front side of the semiconductor wafer **200** with a temporary bonding material **255**, for example, a Crystalbond™ adhesive (FIG. 8K). In some embodiments, the carrier wafer **280** may be the carrier wafer **250** if the process allowed for bonding of the piezoelectric substrate **235** to the

semiconductor wafer **200** without having to remove the carrier wafer **250**. The piezoelectric substrate **235** is then thinned, for example by backside grinding or polishing (FIG. **8L**). After thinning of the piezoelectric substrate **235**, the carrier wafer **280** may be removed (FIG. **8M**), for example, by dissolution of the temporary bonding material **255** with a solvent, for example, acetone.

In act **725**, the resulting finished package structure **300** (FIG. **8M**) may be separated from other packaging structures on the semiconductor wafer **200** and piezoelectric substrate **235** and mounted to a mounting substrate as described above with reference to act **325** of the flowchart of FIG. **3** and FIG. **2L**. In some embodiments, solder balls **230C** may be formed on bond pads **230A** (FIG. **8N**) to facilitate controlled collapse chip connection (C4) solder bonding.

The embodiment described with reference to the flowchart of FIG. **7** may have the advantage of being fully compatible with existing GaAs HBT processing technologies in that it may be performed using the same types of equipment used in existing GaAs HBT fabrication technologies. The microelectromechanical system device(s) **240**, for example, SAW or BAW filters may be hermetically sealed within the cavity **262** in the back side of the semiconductor wafer **200** by the seal ring metallization **225**. The metallization on the upper and side walls of the cavity **262** may assist in shielding the microelectromechanical system device(s) **240** from electromagnetic interference. The provision of the passive devices on the semiconductor wafer **200** may provide for the fabrication of matching circuitry for the microelectromechanical system device(s) **240** within the same package as the microelectromechanical system device(s) **240**. The electrical interconnects through the TWVs may provide low inductance and low impedance connections to the devices formed in the semiconductor wafer **200**. The front side of the semiconductor wafer may be bumped (FIG. **8O**) with the piezoelectric substrate **235** attached, making the package flip-chip compatible. The package **300** may exhibit high mechanical integrity, may be as thin as about 350 μm or less, and may be less expensive to produce than processes involving separately forming semiconductor circuit elements on a semiconductor substrate and microelectromechanical device(s) on a corresponding piezoelectric substrate.

Various modifications may be made to the embodiment described with reference to the flowchart of FIG. **7**. For example, in some variations, the piezoelectric substrate **235** may be bonded to the semiconductor wafer **200** prior to removing the carrier wafer **250** from the semiconductor substrate **200**. Solder bumps **230C** may be formed on the semiconductor wafer **200** before performing the back side processing of the semiconductor wafer **200**. The piezoelectric substrate **235** may be thinned prior to bonding to the semiconductor substrate **200**.

In accordance with another aspect, a combination semiconductor wafer/piezoelectric substrate package may be fabricated in a process involving bonding of the piezoelectric substrate to the semiconductor wafer prior to the formation of devices on the semiconductor wafer. An example of this process is illustrated in the flowchart of FIG. **9** and the images in FIGS. **10A-10M**.

In act **905**, FIG. **10A**, a semiconductor wafer **200**, for example, a GaAs or silicon wafer is etched (wet etch, dry etch, or both) from the back side to form a back side cavity **262**. In act **910** a piezoelectric substrate **235** having preformed microelectromechanical system device(s) **240**, for example, SAW or BAW filters is bonded to the rear side of the semiconductor wafer **200** (FIG. **10B**) with the micro-

electromechanical system device(s) **240** disposed within the back side cavity **262**. Electrical contacts **237** on the top of the piezoelectric substrate **235** that are in electrical communication with the microelectromechanical system device(s) **240** may be electrically and physically bonded to the bottom of the semiconductor wafer **200** or electrical contacts or traces formed thereon with a low temperature eutectic bonding material, for example, solder or TLP bonding material. Seal ring metallization **225** which may include a low temperature eutectic bonding material, for example, solder or TLP bonding material may bond the semiconductor wafer **200** to the piezoelectric substrate **235**. The seal ring metallization **225** may circumscribe the cavity **262**, forming a hermetic seal for the cavity **262** and microelectromechanical system device(s) **240** disposed within the cavity **262**.

In act **915** front side processing of the semiconductor wafer **200** is performed. A carrier wafer **250**, for example, a sapphire wafer is bonded to the rear side of the piezoelectric substrate **235** with a temporary bonding material **255**, for example, a Crystalbond™ adhesive (FIG. **10C**). The semiconductor wafer **200** may then undergo a thinning process, for example, grinding or polishing (FIG. **10D**) from the front side to thin the semiconductor wafer **200** to between about 75 μm and about 100 μm . Through wafer vias **260** are etched (a wet etch or a dry etch or a combination of same) through the front side of the semiconductor wafer **200** to expose upper portions of the contacts **237** (FIG. **10E**).

A layer of metal **265**, for example, copper, aluminum, or another suitable metal or alloy is deposited on the front surface of the semiconductor wafer **200** and makes electrical contact with the tops of the contacts **237** (FIG. **10F**). The front side metallization **265** is patterned to form electrical contacts **298** for filter elements that are provided on the piezoelectric substrate **235** by way of contacts **237**. After thinning, metallization, and metallization patterning of the semiconductor wafer **200**, the carrier wafer **250** may be removed (FIG. **10H**), for example, by dissolution of the temporary bonding material **255** with a solvent, for example, acetone. In other embodiments, the carrier wafer **250** may remain attached to the piezoelectric substrate **235** during the remainder of the front side processing of the semiconductor wafer **200**.

As illustrated in FIG. **10I** a layer of passivation material **210**, for example, silicon nitride or silicon dioxide is deposited on the front side of the semiconductor wafer **200**. Passive devices, for example, inductors **215A** and capacitors **215B** and/or diodes (not shown) are formed on the layer of passivation material **210** on the front side of the semiconductor wafer **200**. Bond pads **230** for providing electrical communication to circuitry outside of the package are also formed on the front side of the semiconductor wafer **200** (FIG. **10J**). The bond pads **230** may be formed of copper, aluminum or another suitable metal or alloy and are electrically and physically connected to the electrical contacts **298**.

In act **920**, the piezoelectric substrate **235** is thinned. A carrier wafer **280**, for example, a sapphire wafer is bonded to the front side of the semiconductor wafer **200** with a temporary bonding material **255**, for example, a Crystalbond™ adhesive (FIG. **10K**). The piezoelectric substrate **235** may then undergo a thinning process, for example, backside grinding or polishing (FIG. **10L**). The carrier wafer **280** is then removed from the semiconductor wafer **200**, for example, by dissolution of the temporary bonding material **255** with a solvent, for example, acetone. In act **925**, the resulting finished package structure **400** (FIG. **10M**) may be separated from other packaging structures on the semicon-

ductor wafer **200** and piezoelectric substrate **235** and mounted to a mounting substrate as described above with reference to act **325** of the flowchart of FIG. **3** and FIG. **2L**.

In accordance with another aspect, a combination semiconductor wafer/piezoelectric substrate package may be fabricated in a process involving bonding of the semiconductor wafer to a carrier wafer with solder balls during backside processing of the semiconductor wafer. An example of this process is illustrated in the flowchart of FIG. **11** and the images in FIGS. **12A-12I**.

In act **1105**, front side processing of a semiconductor substrate is performed. As illustrated in FIG. **12A**, the front surface of a semiconductor wafer **200** is passivated by deposition of a layer of, for example, silicon nitride **210** (e.g., by CVD). Devices are formed on the front surface of the semiconductor wafer **200** using fabrication methods known in the art. The devices may include passive devices, for example, inductor(s) **215A**, capacitor(s) **215B**, and/or diodes **215C** (FIG. **12B**). The passive devices may be utilized in, for example, a matching circuit for filter elements that are provided on the piezoelectric substrate **235** that will be joined to the semiconductor wafer **200**. The devices formed on the front side of the semiconductor wafer **200** may also include one or more active devices, for example, one or more transistors (not shown). Bond pads may be fabricated on the front side of the semiconductor wafer **200** concurrently with, or before or after fabrication of the devices. The bond pads may include bond pads **230A** that will provide electrical communication with components external to the semiconductor wafer/piezoelectric substrate package and contacts **230B** that will provide electrical communication between devices formed on the semiconductor wafer **200** and filter elements that are provided on the piezoelectric substrate **235** that will be joined to the semiconductor wafer **200**. Fabrication of the devices on the semiconductor wafer may further include depositing a layer of a passivation film **220**, for example, silicon nitride or silicon dioxide over the fabricated devices (FIG. **12C**).

In act **1110**, the front side of the semiconductor wafer **200** is solder bonded to a carrier wafer, for example, a sapphire wafer. The bond pads **230A** are exposed, for example, by etching of the passivation film **220** over the bond pads **220A** and solder balls or bumps **230C** are formed on the bond pads **220A** (FIG. **12D**). A carrier wafer, for example, sapphire wafer **250** is brought into contact with and joined to the solder balls or bumps **230C** (FIG. **2E**).

After joining of the carrier wafer to the semiconductor wafer, in act **1115**, backside processing of the semiconductor wafer is performed. With the carrier wafer attached, backside grinding or polishing is performed to thin the semiconductor wafer **200**, for example, to a thickness of between about 75 μm and about 100 μm (FIG. **12E**). Through wafer vias **260** are etched (a wet etch or a dry etch or a combination of same) through the back side of the semiconductor wafer **200** to expose lower portions of the contacts **230B**. A backside etch (a wet etch or a dry etch or a combination of same) is also performed to form a back side cavity **262** in the back side of the semiconductor wafer (FIG. **12F**).

A layer of metal **265**, for example, copper, aluminum, or another suitable metal or alloy is deposited on the back surface of the semiconductor wafer **200** and makes electrical contact with the bottom of the contacts **230B** (FIG. **12G**) and coats the upper and side walls of the cavity **262**. The back side metallization **265** is patterned to form electrical contacts **290** for filter elements that are provided on the piezoelectric substrate **235** that will be joined to the semiconductor wafer **200**, contacts **295** that provide electrical communication

between the filter elements that are provided on the piezoelectric substrate **235** and devices on the semiconductor wafer **200** by way of contacts **230B**, and a metal ring **225** (or other closed geometric structure) that will serve as a seal ring to hermetically seal the back side cavity **262** (FIG. **12H**). After backside processing of the semiconductor wafer **200**, the carrier wafer **250** may be removed (FIG. **12I**), for example, by heating of the assembly to at least partially melt the solder bumps **230C** to allow separation of the semiconductor wafer **200** from the carrier wafer **250**.

In act **1120** a piezoelectric substrate **235** having preformed microelectromechanical system device(s) **240**, for example, SAW or BAW filters is bonded to the rear side of the semiconductor wafer **200** (FIG. **12I**). Electrical contacts **237** on the top of the piezoelectric substrate **235** that are in electrical communication with the microelectromechanical system device(s) **240** may be electrically and physically bonded to the various contacts **290**, **295** on the bottom of the semiconductor wafer **200** with a low temperature eutectic bonding material, for example, solder or TLP bonding material. The seal ring metallization **225** may be bonded to the piezoelectric substrate **235** with a low temperature eutectic bonding material, for example, solder or TLP bonding material and may circumscribe the cavity **262**, forming a hermetic seal for the cavity **262** and microelectromechanical system device(s) **240** disposed within the cavity.

In act **1125**, the piezoelectric substrate **235** may optionally be thinned, for example, in accordance with the methods described with reference to FIGS. **8K-8M** above. In some embodiments, the carrier wafer **250** is left attached to the semiconductor wafer **200** via the solder bumps **230C** until after thinning of the piezoelectric substrate **235**. In act **1130**, the resulting finished package structure **300** (FIG. **12I**) may be separated from other packaging structures on the semiconductor wafer **200** and piezoelectric substrate **235** and mounted to a mounting substrate, for example, using solder balls **230C** on bond pads **230A** to facilitate C4 solder bonding.

The embodiment described with reference to the flowchart of FIG. **11** may have the advantage of being fully compatible with existing GaAs HBT processing technologies in that it may be performed using the same types of equipment used in existing GaAs HBT fabrication technologies. The microelectromechanical system device(s) **240**, for example, SAW or BAW filters may be hermetically sealed within the cavity **262** in the back side of the semiconductor wafer **200** by the seal ring metallization **225**. The metallization on the upper and side walls of the cavity **262** may assist in shielding the microelectromechanical system device(s) **240** from electromagnetic interference. The provision of the passive devices on the semiconductor wafer **200** may provide for the fabrication of matching circuitry for the microelectromechanical system device(s) **240** within the same package as the microelectromechanical system device(s) **240**. The electrical interconnects through the TWVs may provide low inductance and low impedance connections to the devices formed in the semiconductor wafer **200**. The package **300** may exhibit high mechanical integrity, may be as thin as about 350 μm or less, and may be less expensive to produce than packages formed in processes involving separately forming semiconductor circuit elements on a semiconductor substrate and microelectromechanical device(s) on a corresponding piezoelectric substrate.

Embodiments described herein can be implemented in a variety of different modules including, for example, a front-end module, an impedance matching module, an antenna tuning module, an antenna switch module, or the like. FIG.

13 illustrates one example of a module **500** that can include any of the embodiments or examples of the combination semiconductor wafer/piezoelectric substrate package disclosed herein. Module **500** has a packaging substrate **502** that is configured to receive a plurality of components, for example, combination semiconductor wafer/piezoelectric substrate package **504**, which may be any of the embodiments of combination semiconductor wafer/piezoelectric substrate packages disclosed herein. In some embodiments, the combination semiconductor wafer/piezoelectric substrate package **504** can include an RF filter circuit **506**, for example, a SAW or BAW filter and a coupler **508**, or other RF components or circuitry or passive devices known in the art. A plurality of connection pads **516**, for example, solder or gold bumps or posts can facilitate electrical connections to bond pads (not shown) on the substrate **502** to facilitate passing of power and various signals to and from the combination semiconductor wafer/piezoelectric substrate package **504**.

In some embodiments, other components can be mounted on or formed on the packaging substrate **502**. For example, one or more surface mount devices (SMD) **514** and one or more matching networks **512** can be implemented. In some embodiments, the packaging substrate **502** can include a laminate substrate.

In some embodiments, the module **500** can also include one or more packaging structures to, for example, provide protection and facilitate easier handling of the module **500**. Such a packaging structure can include overmold material formed over the packaging substrate **502** and dimensioned to substantially encapsulate the various circuits and components thereon, for example, combination semiconductor wafer/piezoelectric substrate package **504**.

Embodiments of the module **500** may be advantageously used in a variety of electronic devices. Examples of the electronic devices can include, but are not limited to, consumer electronic products, parts of the consumer electronic products, electronic test equipment, cellular communications infrastructure such as a base station, etc. Examples of the electronic devices can include, but are not limited to, a mobile phone such as a smart phone, a telephone, a television, a computer monitor, a computer, a modem, a hand held computer, a laptop computer, a tablet computer, an electronic book reader, a wearable computer such as a smart watch, a personal digital assistant (PDA), a microwave, a refrigerator, an automobile, a stereo system, a DVD player, a CD player, a digital music player such as an MP3 player, a radio, a camcorder, a camera, a digital camera, a portable memory chip, a health care monitoring device, a vehicular electronics system such as an automotive electronics system or an avionics electronic system, a washer, a dryer, a washer/dryer, a peripheral device, a wrist watch, a clock, etc. Further, the electronic devices can include unfinished products.

FIG. **14** is a block diagram of a wireless device **600** including a flip-chip mounted combination semiconductor wafer/piezoelectric substrate package **504** according to certain embodiments. The wireless device **600** can be a cellular phone, smart phone, tablet, modem, communication network or any other portable or non-portable device configured for voice and/or data communication. The wireless device **600** includes an antenna **606** that receives and transmits RF signals, an RF filter circuit **506**, a power amplifier (PA) **610**, and a coupler **508** that can use a transmitted signal for analysis purposes or to adjust subsequent transmissions. For example, the coupler **508** can measure a transmitted RF power signal from the power

amplifier (PA) **610**, which amplifies signals from a transceiver **602**. Coupler **508** and RF filter circuit **506** may be included in a combination semiconductor wafer/piezoelectric substrate package **504**. The transceiver **602** can be configured to receive and transmit signals in a known fashion. As will be appreciated by those skilled in the art, the power amplifier **610** can be a power amplifier module including one or more power amplifiers. The wireless device **600** can further include a battery **604** to provide operating power to the various electronic components in the wireless device.

FIG. **15** is a more detailed block diagram of an example of the wireless device **600**. As shown, the wireless device **600** can receive and transmit signals from the antenna **606**. The transceiver **602** is configured to generate signals for transmission and/or to process received signals. Signals generated for transmission are received by the power amplifier (PA) **610**, which amplifies the generated signals from the transceiver **602**. In some embodiments, transmission and reception functionalities can be implemented in separate components (e.g. a transmit module and a receiving module), or be implemented in the same module. The antenna switch module **608** (which may include the RF filter circuit **506**) can be configured to switch between different bands and/or modes, transmit and receive modes, etc. As is also shown in FIG. **15**, the antenna **606** both receives signals that are provided to the transceiver **602** via the antenna switch module **608** and also transmits signals from the wireless device **600** via the transceiver **602**, the PA **610**, the coupler **508**, and the antenna switch module **608**. However, in other examples multiple antennas can be used.

The wireless device **600** of FIG. **15** further includes a power management system **610** that is connected to the transceiver **602** that manages the power for the operation of the wireless device. The power management system **610** can also control the operation of a baseband sub-system **612** and other components of the wireless device **600**. The power management system **610** provides power to the wireless device **600** via the battery **604** (FIG. **14**) in a known manner, and includes one or more processors or controllers that can control the transmission of signals and can also configure the coupler **508** based upon the frequency of the signals being transmitted, for example.

In one embodiment, the baseband sub-system **612** is connected to a user interface **614** to facilitate various input and output of voice and/or data provided to and received from the user. The baseband sub-system **612** can also be connected to memory **616** that is configured to store data and/or instructions to facilitate the operation of the wireless device, and/or to provide storage of information for the user.

The power amplifier **610** can be used to amplify a wide variety of RF or other frequency-band transmission signals. For example, the power amplifier **610** can receive an enable signal that can be used to pulse the output of the power amplifier to aid in transmitting a wireless local area network (WLAN) signal or any other suitable pulsed signal. The power amplifier **610** can be configured to amplify any of a variety of types of signal, including, for example, a Global System for Mobile (GSM) signal, a code division multiple access (CDMA) signal, a W-CDMA signal, a Long Term Evolution (LTE) signal, or an EDGE signal. In certain embodiments, the power amplifier **610** and associated components including switches and the like can be fabricated on GaAs substrates using, for example, pHEMT or BiFET transistors, or on a silicon or SOI substrate using CMOS transistors.

Still referring to FIG. 15, the wireless device 600 can also include a coupler 508 having one or more directional EM couplers for measuring transmitted power signals from the power amplifier 610 and for providing one or more coupled signals to a sensor module 618. The sensor module 618 can in turn send information to the transceiver 602 and/or directly to the power amplifier 610 as feedback for making adjustments to regulate the power level of the power amplifier 610. In this way the coupler 508 can be used to boost/decrease the power of a transmission signal having a relatively low/high power. It will be appreciated, however, that the coupler 508 can be used in a variety of other implementations.

In certain embodiments in which the wireless device 600 is a mobile phone having a time division multiple access (TDMA) architecture, the coupler 508 can advantageously provide feedback to manage the amplification of an RF transmitted power signal from the power amplifier 610. In a mobile phone having a time division multiple access (TDMA) architecture, such as those found in Global System for Mobile Communications (GSM), code division multiple access (CDMA), and wideband code division multiple access (W-CDMA) systems, the power amplifier 610 can be used to shift power envelopes up and down within prescribed limits of power versus time. For instance, a particular mobile phone can be assigned a transmission time slot for a particular frequency channel. In this case the power amplifier 610 can be employed to aid in regulating the power level of one or more RF power signals over time, so as to prevent signal interference from transmission during an assigned receive time slot and to reduce power consumption. In such systems, the coupler 508 can be used to measure the power of a power amplifier output signal to aid in controlling the power amplifier 610, as discussed above. The implementation shown in FIG. 15 is exemplary and non-limiting. For example, the implementation of FIG. 15 illustrates the coupler 508 being used in conjunction with a transmission of an RF signal, however, it will be appreciated that coupler 508 can also be used with received RF or other signals as well.

Having thus described several aspects of at least one embodiment of this invention, it is to be appreciated various alterations, modifications, and improvements will readily occur to those skilled in the art. Any feature described in any embodiment may be included in or substituted for any feature of any other embodiment. Such alterations, modifications, and improvements are intended to be part of this disclosure, and are intended to be within the scope of the invention. Accordingly, the foregoing description and drawings are by way of example only.

Unless the context clearly requires otherwise, throughout the description and the claims, the words "comprise," "comprising," and the like are to be construed in an inclusive sense, as opposed to an exclusive or exhaustive sense; that is to say, in the sense of "including, but not limited to." The word "coupled," as generally used herein, refers to two or more elements that may be either directly connected, or connected by way of one or more intermediate elements. Additionally, the words "herein," "above," "below," and words of similar import, when used in this application, shall refer to this application as a whole and not to any particular portions of this application. Where the context permits, words in the above Detailed Description using the singular or plural number may also include the plural or singular number respectively. The word "or" in reference to a list of two or more items covers all of the following interpretations

of the word: any of the items in the list, all of the items in the list, and any combination of the items in the list.

Directional terms such as "above," "below," "left," "right," etc. are used herein as a matter of convenience for referencing various surfaces and orientations of features disclosed herein. There directional terms do not imply that the aspects and embodiments disclosed herein are necessarily oriented in any particular orientation. Any dimensions provided in the above disclosure are meant as examples only and are not intended to be limiting.

The above detailed description of embodiments of the invention is not intended to be exhaustive or to limit the invention to the precise form disclosed above. While specific embodiments of, and examples for, the invention are described above for illustrative purposes, various equivalent modifications are possible within the scope of the invention, as those skilled in the relevant art will recognize. For example, while acts of the disclosed processes are presented in a given order, alternative embodiments may perform routines having acts performed in a different order, and some processes or acts may be deleted, moved, added, subdivided, combined, and/or modified. Each of these processes or acts may be implemented in a variety of different ways. Also, while processes or acts are at times shown as being performed in series, these processes or acts may instead be performed in parallel, or may be performed at different times.

The teachings of the invention provided herein can be applied to other systems, not necessarily the system described above. The elements and acts of the various embodiments described above can be combined to provide further embodiments.

What is claimed is:

1. An electronics package comprising:
 - a semiconductor substrate having one or more passive devices formed on the semiconductor substrate and a cavity defined in a first surface of the semiconductor substrate; and
 - a piezoelectric substrate bonded to the semiconductor substrate and having a microelectromechanical device formed on the piezoelectric substrate, the microelectromechanical device disposed within the cavity defined in the semiconductor substrate.
2. The package of claim 1 wherein the one or more passive devices are disposed within the cavity.
3. The package of claim 1 wherein the microelectromechanical device is one of a surface acoustic wave filter and a bulk acoustic wave filter.
4. The package of claim 1 wherein the semiconductor substrate includes a plurality of bond pads formed on a second surface of the semiconductor substrate.
5. The package of claim 4 wherein the piezoelectric substrate includes one or more bond pads electrically connected to one or more of the plurality of bond pads formed on the second surface of the semiconductor substrate.
6. The package of claim 5 wherein the one or more bond pads of the piezoelectric substrate are electrically connected to the one or more of the plurality of bond pads formed on the second surface of the semiconductor substrate by through-wafer vias passing through the semiconductor substrate.
7. The package of claim 1 configured as a flip-chip package.
8. The package of claim 1 wherein the one or more passive devices are disposed on a second surface of the semiconductor substrate opposite the first surface.

17

9. The package of claim 8 wherein the semiconductor substrate includes a plurality of bond pads formed on the second surface thereof.

10. The package of claim 1 further including a seal ring hermetically sealing the cavity.

11. The package of claim 1 wherein side walls and an upper wall of the cavity are coated with a metal film.

12. The package of claim 1 wherein the semiconductor substrate is free of microelectromechanical system (MEMS) devices.

13. The package of claim 1 further comprising a passivation film disposed on the semiconductor substrate and one or more passive devices.

14. A module for an electronic device including an electronics package, the electronics package comprising:

a semiconductor substrate having one or more passive devices formed on the semiconductor substrate and a cavity defined in a first surface of the semiconductor substrate; and

a piezoelectric substrate bonded to the semiconductor substrate and having a microelectromechanical device formed on the piezoelectric substrate, the microelectromechanical device disposed within the cavity defined in the semiconductor substrate.

15. The module of claim 14 wherein the one or more passive devices are disposed within the cavity.

16. The module of claim 14 wherein the microelectromechanical device is one of a surface acoustic wave filter and a bulk acoustic wave filter.

18

17. The module of claim 14 wherein the one or more passive devices are disposed on a second surface of the semiconductor substrate opposite the first surface.

18. The module of claim 14 wherein side walls and an upper wall of the cavity are coated with a metal film.

19. An electronic device including a module for an electronic device, the module including an electronics package, the electronics package comprising:

a semiconductor substrate having one or more passive devices formed on the semiconductor substrate and a cavity defined in a first surface of the semiconductor substrate; and

a piezoelectric substrate bonded to the semiconductor substrate and having a microelectromechanical device formed on the piezoelectric substrate, the microelectromechanical device disposed within the cavity defined in the semiconductor substrate.

20. The electronic device of claim 19 wherein the one or more passive devices are disposed within the cavity.

21. The electronic device of claim 19 wherein the microelectromechanical device is one of a surface acoustic wave filter and a bulk acoustic wave filter.

22. The electronic device of claim 19 wherein the one or more passive devices are disposed on a second surface of the semiconductor substrate opposite the first surface.

* * * * *